

INSTRUCTION MANUAL  
MODEL 100 V  
EXCITER-TRANSMITTER



*Central Electronics, Incorporated*

A subsidiary of Zenith Radio Corporation

AMATEUR — COMMERCIAL — MILITARY — COMMUNICATION EQUIPMENT

#### 100V ACCESSORY BAG:

The following items are packed separately in a small bag which has been placed inside the shipping crate:

1. 1 - Plug, 4 prong, Cinch-Jones P304 CCT
2. 1 - Plug, 2 prong, Cinch-Jones P302 CCT
3. 1 - Socket, 2 terminal, Cinch-Jones S302 CCT
4. 1 - Plug, 3 circuit telephone type, Switchcraft #267
5. 1 - Fuse, 8 ampere, type 3AB, medium time lag  
Littlefuse #314008
6. 1 - Allen wrench, #10 (for large knobs)

The 4 prong plug provides access to the Internal Relay contacts. A Jumper has been installed from terminal 2 to terminal 4, which applies line voltage to the TO ANT RLY 115V AC 25 WATTS socket. For keying other apparatus, where 115V AC is not required, be sure to remove the jumper.

The 2 prong plug should be soldered to the speaker voice coil leads and the 2 terminal socket to the receiver output transformer as described in the Receiver Connection Diagram.

The 3 circuit telephone type jack provides access to the blocking bias circuit.

### ONLY ONE TUNING CONTROL - THE VFO:

All other circuits are either fixed frequency or band pass, using the Multiphase patented No Tuning Broad-band Couplers. A single knob band switch selects all bands and antennas with the accessory AS-100 switch.

### BUILT IN PRECISION LINEAR VFO:

The oscillator circuit is self-compensating for changes in tube transconductance (U.S. Patent #2,867,725) caused by line voltage fluctuations or ageing. It is exceptionally rugged and permeability tuned by a precision stainless steel lead screw mounted in preloaded ball bearings. Frequency is read directly in 1 kilocycle increments in the circular "kilocycle" window. A slide-rule Megacycle scale rotates with the bandswitch so only the band in use appears in the window. Frequency is read directly without addition or computation with approximately 10 feet of band spread on each 1 megacycle range. For maximum operating convenience a two speed knob provides fast tuning at 100 kilocycles per turn and slow tuning at 750 cycles per turn.

The frequency drift is less than 25 cycles in any 10 minute period after a five minute warm up.

The VFO is calibrated to zero beat accuracy every 50 kilocycles. Calibration error does not accumulate from one end of the band to the other. It can be recalibrated right at your operating position without removal from the exciter.

### DOUBLE HETERODYNE CIRCUIT:

The VFO covers 5 to 6 megacycles and is heterodyned against crystal controlled oscillators or the master 6 megacycle signal, as determined by the bandswitch, to provide output on all bands. With this method the sideband generator operates at a fixed crystal controlled frequency, therefore rebalancing is unnecessary each time the band is changed.

For maximum stability all oscillators in the heterodyne system oscillate continuously.

Blocked grid keying is used on the mixers and linear amplifiers to provide clickless, chirp free operation.

100V  
5/5/59  
Rev. 10/13/59  
Printed in USA

## FREQUENCY COVERAGE:

A single knob bandswitch changes Broadband Couplers (U.S. Patent #2,364,060) in all stages. The 100V covers all of the 80, 40, 20, 15 and 10 meter bands with one switch position per band. Power output is constant across the following bands:

80 meters	-	3.5 to 4.5 megacycles
40 meters	-	6.5 to 7.5 megacycles
20 meters	-	13.5 to 14.5 megacycles
15 meters	-	20.5 to 21.5 megacycles
10 meters	-	27.7 to 29.7 megacycles

There is a generous overlap beyond the Amateur bands for MARS, CAP and commercial applications. The VFO has 50 kilocycles of overtravel at each end (100 KC above 25.6 MC) for which accuracy and linearity are not guaranteed. External crystals in the 5 to 6 megacycle range may be used for frequency control.

A spare position is provided to permit installation of Broadband Couplers for 160 meters (1750 to 2500 kc.) or any 1 megacycle section of the spectrum not covered by the amateur bands such as 4500 kc. to 5500 kc., 5500 kc. to 6500 kc., 7500 kc. to 8500 kc., etc. Note that these begin and end at .5 mc. points ONLY. A 2 mc. range is available from 25.6 to 27.6 megacycles. Operation in the 50 to 64 mc. amateur band is not practical; we suggest the use of our accessory 6 and 2 meter converter for this purpose.

## ONLY FOUR OPERATING CONTROLS:

**FUNCTION SWITCH:** Power OFF, Standby, VOX (Voice Controlled Break-in), PTT (Push to Talk) and Manual.

**BAND SWITCH:** A single knob selects 80, 40, 20, 15 or 10 meters, with a spare position for special applications. A lever switch under the band switch knob changes the meter to read Watts Input 0-200, RF AMPS output 0-1.5, or A.C. LINE voltage.

**CALIBRATE LEVEL:** Varies the calibrate output to suit band conditions or variations in installation. A lever switch under the Level Control has three positions: VOICE-OFF-CARRIER. The VOICE calibrate position allows you to "talk yourself on frequency". The CARRIER calibrate position provides an unmodulated carrier for zero beating purposes. When using Calibrate Carrier for zero beating another station, the VOX relay will remove the carrier in the transmit position.

#### EMISSION SELECTOR: (TEN POSITION)

- 1 - NULL To check carrier null for suppressed carrier functions
- 2 - LSB Lower Sideband with suppressed carrier
- 3 - USB Upper Sideband with suppressed carrier
- 4 - DSB Double Sideband with suppressed carrier
- 5 - LS-C Lower Sideband with preset carrier
- 6 - US-C Upper Sideband with preset carrier
- 7 - AM Double Sideband with preset carrier
- 8 - PM Phase Modulation with preset carrier
- 9 - CW Four ways to key with preset carrier
- 10 - FSK Frequency Shift Keying for Teletype with preset carrier

In the NULL position, the meter reads carrier suppression in decibels below maximum output and the reading is valid for any setting of the POWER OUTPUT control. The selector has an automatic spring return to the LSB position.

#### SET AND FORGET CONTROLS:

There are two magnetic doors on the front panel of the 100V. They conceal seldom used controls such as Speech Level, Voice Control Trip Level, Anti-Trip Level, VOX Relay Release Time, Carrier Null Controls A and B, Preset AM Carrier, Preset CW and PM Carrier, Power Output, FSK Deviation, FSK and CW Monitor Level, Xtal-Vfo switch and External Xtal Frequency corrector.

#### MISMATCH INDICATOR:

Whenever the standing wave ratio becomes excessive in the output RF load circuit of the Exciter, the screen grid overcurrent relay will add protective grid bias to the stage, operate the MISMATCH INDICATOR and provide an audible alarm.

#### LIMITER INDICATOR:

Provides a visual indication of the amount of speech clipping in use. For normal operation, the Speech level control should be advanced to the point where the indicator flashes only occasionally, which indicates approximately 3 db. of clipping. Under adverse transmitting conditions the Speech Level may be advanced to the point where the bulb flashes rapidly or glows faintly almost continuously, which indicates approximately 10 db. of speech clipping

#### TWO INCH MONITORING OSCILLOSCOPE:

The internal oscilloscope continuously monitors linearity of all stages from the Balanced Modulator to the RF output connector, and also furnishes a positive indication of the percentage of modulation on AM. It assures top performance while the unit is on the air.

The Intensity and Focus controls are adjustable through the top of the cabinet.

#### ADVANCED PHASING SSB GENERATOR:

Central Electronics is once again years ahead of the field with a new approach to SSB generation, - sparkling performance that exceeds a filter with equal long term stability! No tuning Broadband techniques have even been applied to the balanced modulator making it non-critical. Carrier suppression is completely stable in excess of 50 db below maximum output. The NULL position on the EMISSION selector connects the meter to indicate db carrier suppression with readability down to less than 50 db below full output.

A new Audio Phaseshift Network, the PS-2 is constructed with heat cycled stable components with .1% accuracy. The PS-2 in combination with its associated circuits is capable of at least 50 db of unwanted sideband suppression. To insure long term audio amplitude balance, 35 db of inverse feedback is applied around the modulator system. It is possible to change modulator tubes without affecting the sideband suppression. The RF phaseshift circuit is also a non-critical, low impedance, wide band design to provide the ultimate in SSB suppression and long term stability.

#### METER:

The illuminated 2 inch rectangular meter indicates the final amplifier Power Input, RF Output Current, Carrier Suppression and AC Line Voltage. The fixed operating bias on the final amplifier stage will provide a resting plate dissipation 50 to 60 watts when no RF drive power is applied. The scale is marked for proper input power for both AM and CW. The power input for PM and FSK should be the same as that used for CW. When operating DSB or SSB with suppressed carrier the meter will not read much higher than about 100 watts with 3 db. of speech clipping.

When the speech clipping is increased to about 10 db. the average meter reading will be slightly higher. The meter should never be used as an indicator for suppressed types of speech transmission due to the fact that it is unable to follow the intricate voice peak patterns. Only the oscilloscope can indicate the voice peaks and should be used for speech monitoring. The maximum meter reading with speech may be used to determine the FCC power rating.

With 175 watts CW input to a low reactance load, the antenna current will be 1.4 amperes in 50 ohms and 1.18 amperes in 72 ohms.

The LINE meter scale indicates the AC voltage operating extremes recommended for this equipment. At the letter "L" the voltage is 100 and at "H" the voltage is 125. Below 100 volts the power output drops readily and the voltage regulator tubes may extinguish. Operation at voltages in excess of 125 may shorten the life of some components.

ZERO SETTING. A slotted-head screw located on the panel just below the TUNING knob can be used to set the hairline on the kilocycle scale to provide very accurate readings when set against a crystal standard.

## SECTION II

### INSTALLATION

The 100V is shipped ready to connect and operate. If it has been damaged during shipment, an insurance claim should be filed with the carrier.

#### UNPACKING

1. Open the three wire latches on one corner of case.
2. Remove the packing material and check carefully for small packages.

The crate should be retained for possible future re-shipment. Due to the weight of the equipment, the use of cardboard containers is not recommended.

#### POWER SOURCE:

The 100V is designed for use with 115 volt 50 to 60 cycle A.C. only. Power circuit wiring should have #16 gauge minimum conductor size to prevent loss of power and poor line regulation. The A.C. line circuit by pass capacitors are arranged so that when the plug is inserted in one polarity, no shock will be experienced when making contact between the chassis and any ground object. Correct polarity may be determined by touching a ground wire to the chassis and reversing the plug if necessary until no sparking is observed.

**CAUTION:** Use a heavy, short ground connection to the  $\frac{1}{2}$  inch stud on the rear of the chassis. The 100V, the receiver, linear amplifier and linear amplifier power supply (if used) should be bonded together to preclude the possibility of electrical shock due to a faulty component.

#### PHYSICAL LOCATION:

The 100V should be located in such a position that strong drafts from open windows or other intermittent forced air ventilating, heating or cooling systems will not strike the unit directly. Allow sufficient clearance on each side for normal ventilation. Antenna tuners, end fed antennas or untuned and tuned antenna feeders should not be placed in close proximity to the 100V or any of the external connections, particularly when a high power linear amplifier is used. Avoid placing of the antenna or feeders in a position where any appreciable amount of RF is coupled to the power wiring.

#### MICROPHONE:

Microphones having a relatively flat or moderate rising characteristic should be used. Sufficient gain is available in both the speech and VOX circuits for microphones having an output as low as minus 65 db.

#### ANTENNA:

The 100V output circuit is designed for use with either 52 or 72 ohm coaxial cable. Type RG 58U or RG 59U may be used for reasonably short runs on the lower frequencies.

100V

5/5/59

Printed in USA



At 28 megacycles the loss in these smaller cables is 2 to 3 db. per hundred feet even when brand new, so RG 8U or RG 11J should be used.

The Broadband output couplers in the 100V are designed to deliver maximum undistorted power into unbalanced 50 to 72 ohm loads. For best results, the SWR should not exceed 2 to 1. The 100V will work into higher standing wave ratios; however, it is to your advantage to provide the best possible match between the antenna and the feed line. This will radiate the maximum amount of signal. Antenna reactance cannot be tuned out at the transmitter even with a Pi network; it must be tuned out by adjusting the antenna length.

If the antenna impedance is other than 50 to 72 ohms unbalanced, a balun or antenna tuner must be used.

When individual antennas or final amplifiers are used on each band, the accessory AS-100 antenna switch is available for installation on the rear of the chassis. It is linked mechanically to the bandswitch and automatically selects the proper antenna or amplifier.

Multiband trap antennas or multiple dipole antennas can be used due to the low harmonic output of the 100V in comparison to class AB2, B, or class C amplifiers.

Either a coaxial relay, or any of the popular TR switches may be used for switching the antenna from the transmitter to the receiver. Recommended relays are the Advance type CB/ 1C 2C/ 115 VAC or the Dow type DKC-GE-115V. The internal relay in the 100V furnishes keyed 115 volts AC for antenna relay operation. The auxiliary contacts on these relays must also be connected to the 100V as described in the Antenna Relay Connection Diagram.

### SECTION III

#### CONTROLS

##### 1. SET AND FORGET CONTROLS:

**SPEECH LEVEL.** Adjust to required level for proper modulation as indicated on the oscilloscope. Each division on the scale indicates 6 db., approximately.

- VOX TRIP LEVEL. Varies the sensitivity of the VOX circuit. Advance the control to the point where the first letter of a spoken word operates the relay reliably.
- ANTI-TRIP LEVEL. This control prevents loudspeaker signals from tripping the VOX relay. With a loud signal tuned in, advance the control to the point where the relay will not trip.
- VOX RELAY RELEASE TIME. Varies the time constant of the relay release. Adjust for desired time.
- FSK DEVIATION. Adjusts the Frequency shift deviation from about 100 cycles to 900 cycles. This will remain constant on any band or frequency.
- CARRIER BAL. controls A and B. With the EMISSION switch in the NULL position, adjust for minimum carrier indicated on the front panel meter in DB. Allow a few minutes for Exciter to warm up before adjustment.
- PRESET AM CARRIER. With the EMISSION SELECTOR in the AM position adjust for 100 watts input on meter.
- PRESET CW CARRIER. With the EMISSION SELECTOR in the CW position adjust for any value up to 175 watts input. Also presets PM carrier level.
- POWER OUTPUT. Controls the level of the 8 mc. master generating system at the grid of the first mixer. Varies the power output of the exciter from maximum down to about 10 watts output for driving amplifiers that require less power.
- XTAL-VFO SWITCH. For changing from internal VFO to external crystal controlled operation. Use crystals in the range of 4950 to 6050 KC.
- EXTERNAL XTAL CORRECTOR. Provides frequency adjustment for the external 4950 to 6050 KC crystal to obtain exact calibration.
- EXTERNAL XTAL. For external 4950 to 6050 KC crystals.
- CW AND FSK MONITOR LEVEL. Adjusts the receiver output level in the phones or speaker in the CW VOX, CW MAN, CW PTT and FSK positions for monitoring purposes.

## 2. CONTROLS ON TOP OF THE CHASSIS:

AF RATIO potentiometer. Balances the AF input voltages to the PS-2 audio phase shift network. Controls sideband suppression. See chapter on Sideband Suppression adjustment.

AF BAL. potentiometer. Equalizes the output of the AF modulator tubes. Controls sideband suppression. See chapter on Sideband Suppression adjustment.

ADJ. LIM. IND. potentiometer. Determines the level at which the LIMITER indicator operates. With the Speech Level turned off, turn the control S L O W L Y clockwise until the neon indicator starts to glow. Now turn the control slowly counterclockwise until the indicator becomes extinguished.

SCOPE WIDTH potentiometer. Adjusts the width of the pattern on the cathode ray tube.

INTENSITY potentiometer. Controls the intensity of the pattern on the cathode ray tube.

FOCUS potentiometer. For focusing the pattern on the cathode ray tube.

METER ADJ. potentiometers. The three meter adjustment potentiometers, WATTS IN, AC LINE and AMPS OUT are located inside the shielded compartment which contains the 6550 tubes.

## SECTION IV

### REAR CONNECTIONS

ANTENNA receptacle. UHF type S0239 for 50 to 72 ohm unbalanced load.

Use coaxial cable, any length down to a minimum of 6 feet is recommended to properly terminate the Broadband Output Couplers.

TO ANT RELY 115 VAC 25 WATTS socket. Provides keyed 115 VAC for antenna relay operation with jumper connected between 2 and 4 on INT RELAY plug.

INTERNAL RELAY socket. With a jumper between 2 and 4 on the plug, will provide keyed 115 VAC at the antenna relay AC socket. All plugs have this jumper installed. For keying other apparatus (without 115 VAC) BE SURE TO REMOVE THIS JUMPER. 4 and 1 are closed in transmit, 4 and 3 are closed in receive. Pin 2 is always connected to the 115 VAC line.

PTT MIC jack. For push-to-talk microphone operation. Pin 1 is the microphone lead, and pin 2 is for the switch. Use Amphenol MC2M connector.

PHONE jack. When high impedance phones are plugged in the speaker is muted in receive and the phones are muted in transmit.

CW MAN-VOX jack. With the FUNCTION switch in the VOX position, the first keying pulse will close the internal relay (and antenna relay, if used) for a period of a few milliseconds up to about 1 second, depending upon the adjustment of the VOX Relay Release Time potentiometer. BE SURE TO RETARD THE QT CONTROL WHEN USING VOX CW. THIS WILL PERMIT A LONGER DELAY TIME. With the FUNCTION switch in the MANUAL position, the relays remain closed and only the blocking bias is keyed. Receiver remains muted.

CW STBY jack. Keys blocking bias only. Receiver is not muted and antenna relay will not operate. A TR switch, manually operated antenna switch, or separate receiving antenna must be used.

CW PTT jack. Keys the internal relay (and antenna relay, if used) for instant positive break-in operation.

RECVR OUTPUT socket. Remove the leads from the secondary of the receiver output transformer and solder them to the 2 terminal Jones female RECVR VC plug. An internal 2 watt 10 ohm resistor is connected across these terminals internally for use with 3 to 8 ohm speakers. Replace with 1000 ohms for 600 ohm outputs, and 10,000 ohms for 5000 ohm outputs. Pin 1 is internally grounded. Insert the plug in the 100V.

SPEAKER V.C. socket. Solder the speaker voice coil leads to the 2 prong Jones male connector, and plug into the 100V. Pin #1 is grounded internally.

- MIC connector. For high impedance microphones, down to -65db. Microphones with essentially flat response should be used.
- BIAS jack. Requires 3 circuit plug, provides -100V DC blocking bias for keying external linear amplifiers. If an external antenna relay is used, connect its auxiliary "make" contacts to the "tip" and "ring" circuit of the bias plug. Connect the "positive" end of a "floating" bias supply to the tip circuit of the plug. In this way the -100V DC will add to the normal operating bias of the linear amplifier during standby. The VOX relay will ground the tip circuit after the antenna relay has closed, restoring the bias to normal during transmit. The -100V DC can not be used as a source of operating bias for an external linear amplifier.
- AF IN jack. Approximately 0.2 volts are required for full Exciter output. For use with audio oscillator, phone patch, etc.
- FSK-1 jack. For FSK keying with a polar relay.
- FSK-2 jack. For FSK keying without a polar relay.
- VFO IN jack. Normally connected to VFO OUT jack. For use when VFO is remotely located.
- VFO OUT jack. Normally jumpered to VFO IN jack.
- AF OUT jack. Provides approximately .15 volts from the cathode follower after the speech clipper and filter, to obtain trapezoid patterns for external linear amplifiers on an external oscilloscope. Can be used to drive other speech equipment such as modulators, etc.
- FUSE: Type 3AB, 8 amperes.

## SECTION V

### OPERATION

The following adjustments are required for all types of operation and should be made in the following sequence.

#### 1. SINGLE SIDEBAND SUPPRESSED CARRIER ADJUSTMENT:

An antenna or dummy load (100 watts) must be connected to the RF output. Be sure the POWER OUTPUT potentiometer located behind the right door is turned completely clockwise (maximum).

Turn the FUNCTION switch to STANDBY, the EMISSION switch to LSE (lower sideband) the Bandswitch and VFO to desired frequency.

Allow a few minutes for the unit to warm up. With the EMISSION switch in the NULL position adjust the Carrier Balance controls for minimum carrier as indicated on the meter. With the EMISSION switch in one of the SB positions and the OPERATION switch on MANUAL advance the Speech Level control until the LIMITER indicator light only flashes occasionally during average speech. With only an occasional flash, there will be about 3 db. of speech clipping and this is the maximum that should be employed for normal operation. Under adverse transmitting conditions when reception is weak or interference exists, the speech level may be increased to the point where the indicator flashes rapidly or sometimes remains on continuously, although weak. At this setting (about 10 db. clipping) there will be an appreciable increase in intelligibility at the receiving end with a tolerable amount of distortion and no "splatter". Increasing the speech level to the point where the indicator lights brightly (about 20 db. clipping) will result in excessive distortion and loss of intelligibility. Each division on the Speech Level scale indicates 6 db., approximately.

With the FUNCTION switch in the VOX position, advance the VOX gain control to the point where consonants will operate the relay reliably. For example, the "f" in "four" should operate the relay consistently.

Now adjust the relay RELEASE time potentiometer so that it will not release between consecutive words in a sentence under average speech.

With a loud heterodyne or other signal from the loudspeaker, advance the QT potentiometer to the point where the relay will not trip. For this adjustment, the microphone and loudspeaker must be in their normal operating position.

100V SET AND FORGET CONTROLS

LEFT DOOR

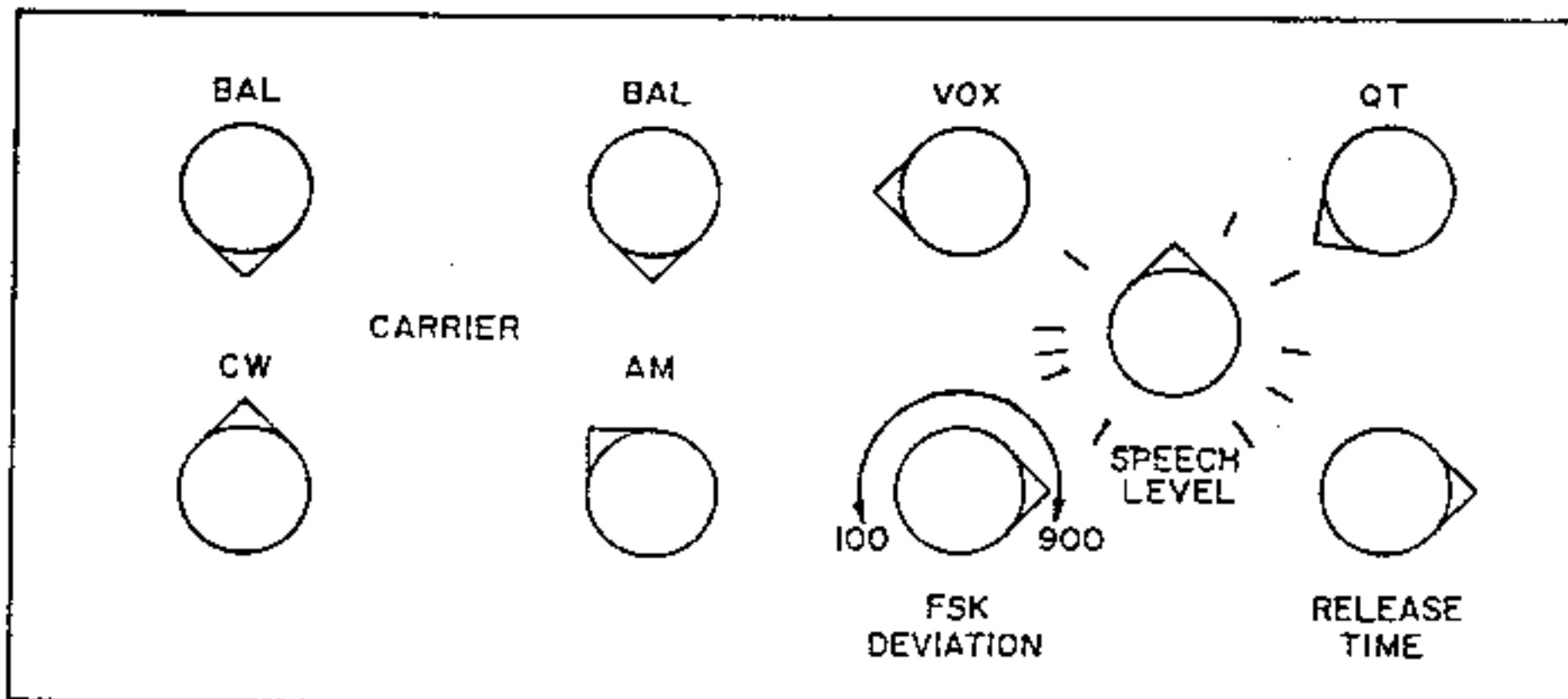

RIGHT DOOR

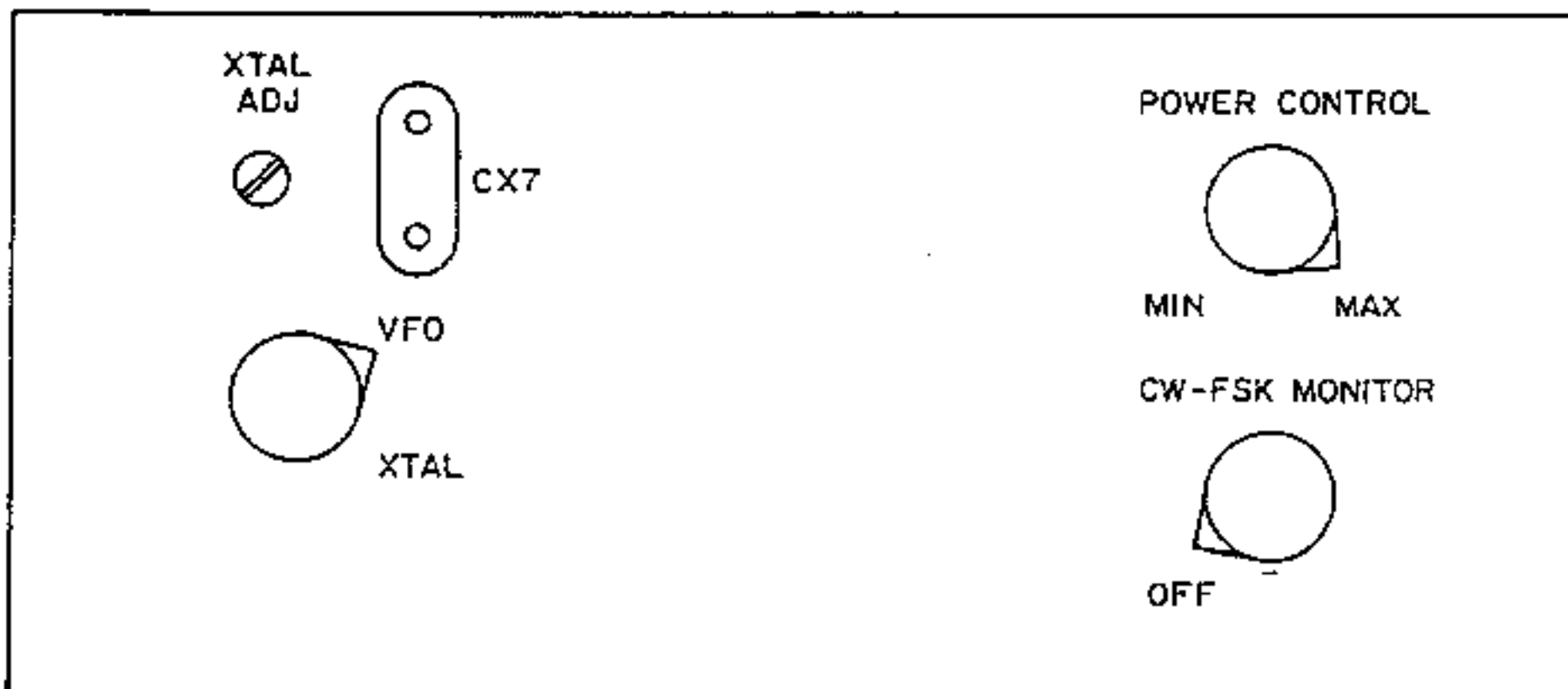

## 2. AMPLITUDE MODULATION ADJUSTMENT:

With the EMISSION switch on AM and the FUNCTION switch on MANUAL, adjust the AM carrier potentiometer (behind the left door) for 100 watts input. average speech, there should only be a perceptible upward movement on the power input meter. Any appreciable movement of the meter while operating with carrier types of transmission (AM, USC, LSC,) indicates overloading of the final amplifier, and will give distortion.

The speech level has been adjusted to the proper value under the SSB adjustment, and is automatically reduced 6 db. by the EMISSION switch for proper AM linear operation. Once these levels have been determined, it is possible to change to any mode of operation without any further adjustment.

## 3. PM AND CW CARRIER ADJUSTMENT:

With the emission switch in the PM position and the FUNCTION switch on manual, adjust the CW CARRIER control for 175 watts input. If the control is set at a higher value, the final amplifier will draw grid current and will give a considerable increase in harmonic output which can cause TVI, while the increase in power output only amounts to about 1 db. or approximately 1/6 of an S unit on the average receiver.

In the PM position, the speech level is preset by the EMISSION SWITCH. Phase modulation generated by this method has the same bandwidth as amplitude modulation and is the maximum deviation permitted in the amateur bands below 29 megacycles.

## SECTION VI

### TELEVISION INTERFERENCE

The output of the second and higher order harmonics of the 100V are down in excess of 50 db. from full output. Ordinarily this will not create harmonic TVI in primary TV service areas. If TVI due to harmonic radiation is present, a good low pass filter should be connected as close to the RF output connector as possible.



It is very important that the final amplifier is not driven to the region of grid current. Whenever grid current flows the harmonic output increases considerably and is almost certain to create TVI. In cases where harmonic TVI persists even after a low pass filter is installed, it may be necessary to retard the POWER OUTPUT control slightly to insure that the final amplifier tubes are operating in the linear portion of their Eg Ip curve.

If the 100V is connected to an antenna that has an appreciable standing wave ratio, the final amplifier will "flat-top" and generate strong harmonics at values below the rated maximum input, so it is essential that the SWR be kept as low as possible.

TVI may be caused by an antenna relay in which the antenna contacts are subject to RF arcing due to improper timing sequence of the auxiliary contacts, TR switches, SWR meters and other devices which contain diodes. The TVI from rectifying devices can usually be reduced by using a low pass filter between the unit containing the rectifier element and the antenna.

The auxiliary contacts on the antenna relay should be adjusted so that the bias contacts open before the antenna contacts do, when the relay is de-energized.

## OPERATING NOTES

1. FLAT TOPPING. When the trapezoid indicates flat topping while operating on SSB, DSB or AM, RETARD THE POWER OUTPUT CONTROL. Specifications allow for some reserve RF driving power to allow for tube aging. When the LOCV is operated into an excessively high load impedance, it will be necessary to further reduce the control. The correct power output control setting can be determined by talking into the microphone with full speech gain until the limiter indicator lights, and adjusting the power output control for a proper trapezoid. Remember that the trapezoid only indicates the linearity of the stages between the balanced modulator and the antenna. It does not show audio distortion or speech clipping in this equipment.

If there is an appreciable departure from the original height when the 2AP1 tube is changed, it will be necessary to change the value of the RF coupling capacitor, C404.

2. FSK DEVIATION. If the frequency deviation is less than 850 cycles with the control at maximum, the XTAL OSC PLATE coil must be retuned. The iron core tuning slug should be tuned for maximum output first and then turned counterclockwise not more than 1/4 turn. If the slug is turned counterclockwise more than 1/4 turn, the sideband suppression will be affected. Try changing V11, since these tubes vary considerably.

3. HIGH FREQUENCY CRYSTAL OSCILLATOR STABILITY. The HF crystal oscillator plate coils are adjusted for greatest stability rather than maximum output. Greatest stability and maximum output will not necessarily coincide. They should be adjusted for minimum chirp by keying the transmitter on CW with carrier inserted while monitoring the note in a receiver. By using a low pitched beat note during the monitoring process, slight changes in frequency may be easily determined.

4. ANTENNA RELAY SPARK SUPPRESSION. C241A, a .02 mfd. ceramic capacitor has been connected to relay terminals 11 and 12 to suppress the keying spark when an antenna relay or other inductive device is keyed. Without a capacitor the keying transient will be picked up by the Vox Amplifier circuit and cause the Vox Relay to continue pulsing automatically after the operator stops talking. C241A has been included in all units having serial numbers higher than 185. Units having serial numbers 185 and below contained a .05 paper capacitor C307A, located on the back of the Jones 4 terminal INTERNAL RELAY SOCKET mounted on the rear of the power supply chassis. Locating the capacitor at the relay terminals is more effective than at the relay socket. When C241A is installed, C307A is no longer necessary. If the Vox Relay is used to key circuits which do not induce a transient, and the effect of the capacitor is deleterious to circuit operation, the capacitor should be removed.

LOCV

5/5/59

Rev. 2/19 and 4/5/60

Printed in USA

5. UNDESIRABLE RELAY OPERATION CAUSED BY EMISSION SWITCH. When the FUNCTION switch is in the VOX position, the Vox Relay will operate momentarily when turning the EMISSION selector through the CW position if no key is inserted into the CW-VOX jack.

This keying pulse can be avoided by placing the selector in STANDBY or FTT when switching through the CW position.

6. When operation is contemplated on VOX CW and VOX FSK, it will be necessary to use a shorting switch on the microphone or remove the microphone plug to prevent room noises from operating the relay.

7. Under certain circumstances (especially when a linear amplifier is used) it may be necessary to advance the CAL LEVEL potentiometer almost to maximum in order to hear the calibrate signal in the receiver. This can sometimes cause TVI, especially when calibrate carrier is used, or distortion when vox calibrate is used. To prevent this it will be necessary to couple some of the RF output from the LCOV to the receiver. This may be done by using a "T" connector at the RF output of the LCOV and using a small coupling capacitor having a value of 2 or 3 micro-microfarads, or by twisting a few inches of insulated hook-up wire together and coupling to the receiver antenna input. If the receiver uses a coaxial connector, another "T" connector must be used. When possible, coaxial cable should be used for the connecting lead and it should be kept as short as possible.

100V OSCILLOSCOPE PATTERNS

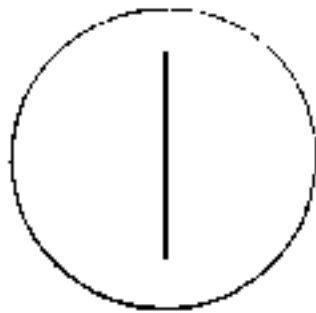

CW or FM Carrier

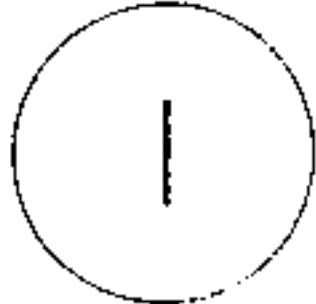

AM Carrier - No Modulation

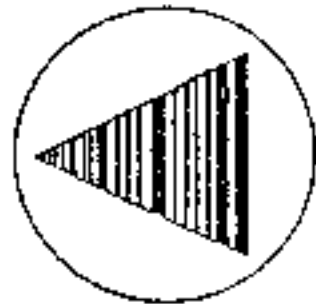

AM 100% Modulated

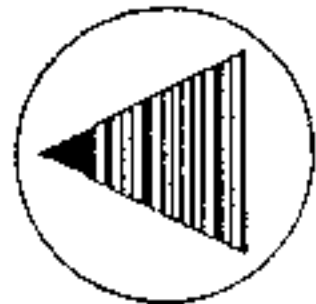

AM Over-modulated (Insufficient Carrier Insertion)  
Note Bright Area at Tip

AM - Low Percentage of Modulation (Excessive Carrier Inserted)



AM - Excessive Carrier Plus Flat Topping  
REDUCE CARRIER AND RETARD POWER OUTPUT CONTROL



SSB Properly Modulated



AM or SSB  
1. Too much RF Drive  
2. Improper Loading  
When this pattern is obtained  
RETARD THE POWER OUTPUT CONTROL  
UNTIL A PROPER TRAPEZOID IS SECURE.

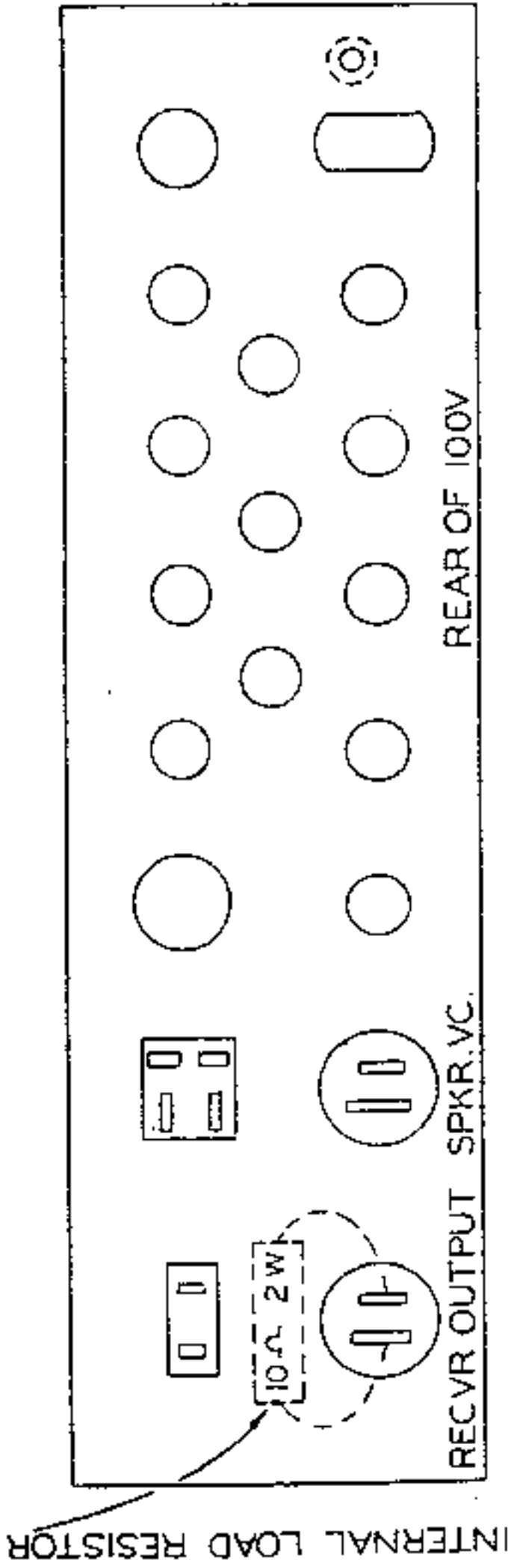

#1 (WIDE CONTACT) #2 (NARROW CONTACT)

AUXILIARY SOCKET

AUXILIARY PLUG

SPKR. VOICE COIL

BE SURE TO CONNECT WIDE CONTACT (#1) (RECVR OUTPUT)

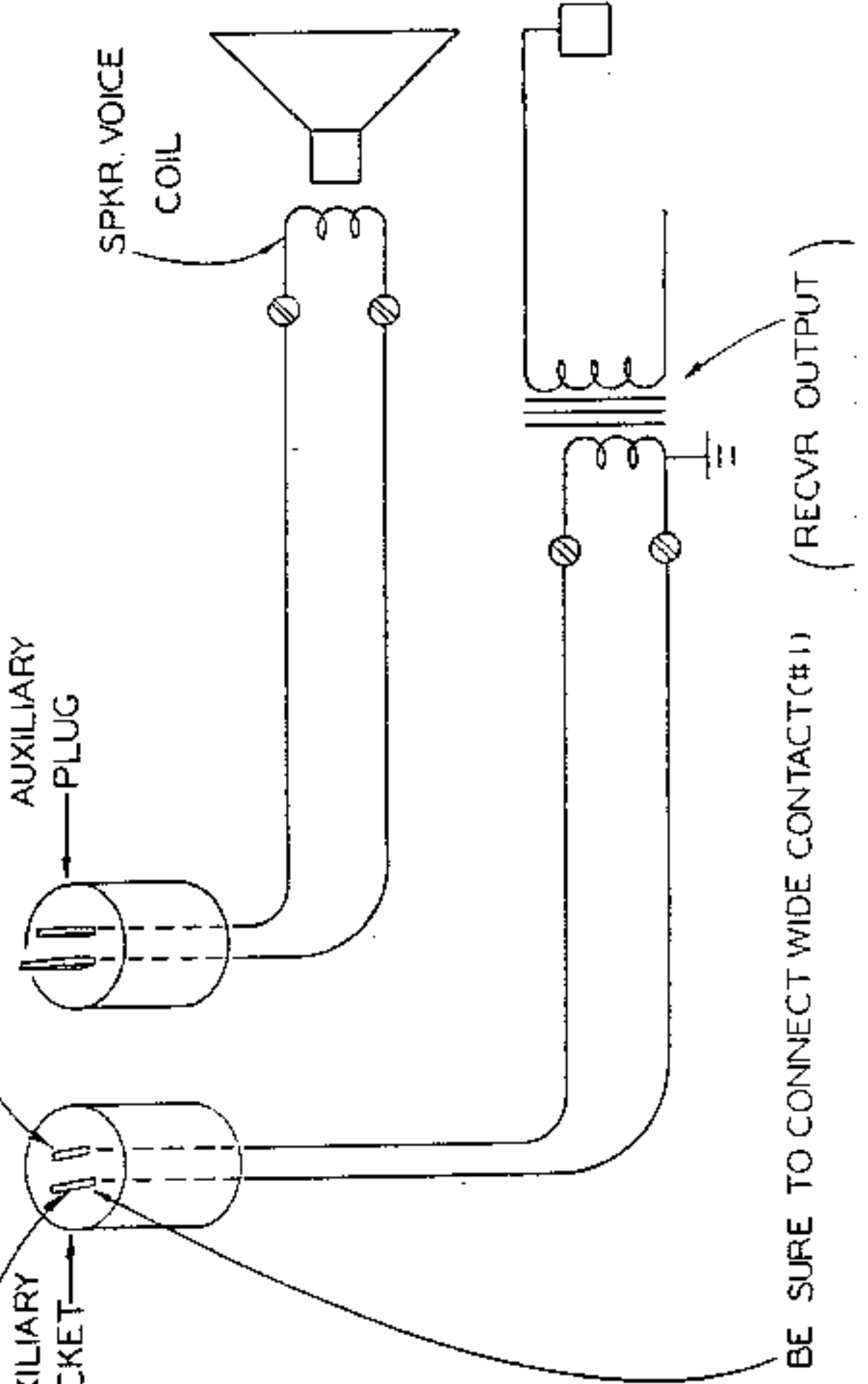

CENTRAL ELECTRONICS, INC.  
 1247 BELMONT AVE.  
 CHICAGO 13, ILL.

ANTENNA RELAY CONNECTIONS  
 FOR 100V

P207

4-9-59

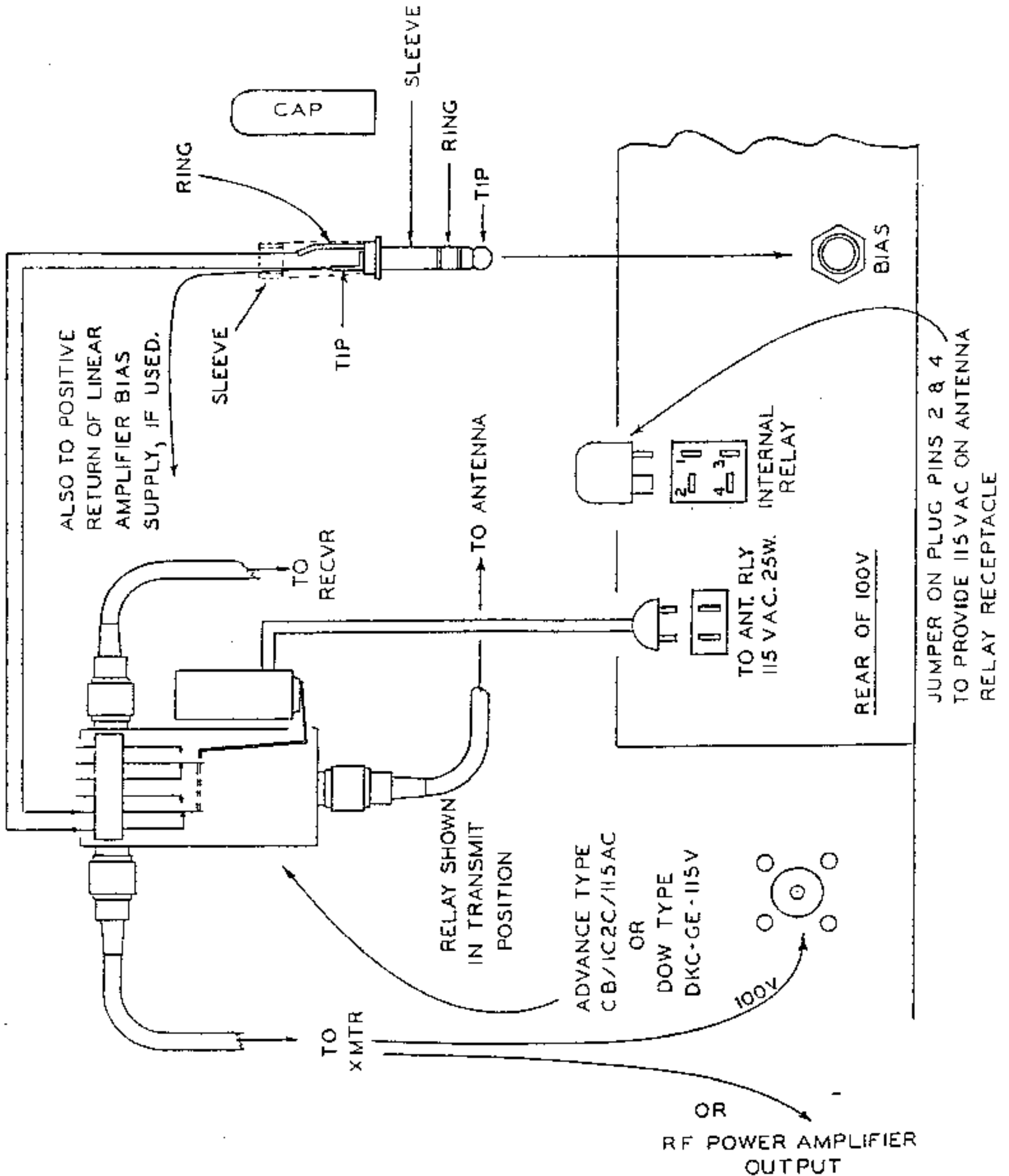

## SECTION VII

### THEORY OF OPERATION

#### POWER SUPPLY:

The power supply consists of three separate supplies; a bias supply, a low voltage supply and a high voltage supply. The bias supply delivers 100 volts negative. The low voltage supply of approximately 340 volts furnishes the B-plus to all tubes except the final plate and the oscilloscope, which are fed from the high voltage supply of 600 volts. A selenium rectifier is used for the bias supply, a 5U4GB (V23) for the low voltage supply and a pair of 6AU4GTAs (V24 and V25) are used for the high voltage supply.

#### MICROPHONE PREAMPLIFIER:

The pentode section of a 6UBA tube, V1A, is used as the microphone preamplifier. An R-C radio frequency filter is used at the input grid circuit. The output of this stage is applied to the MIC GAIN and QT gain controls. The "hot" side of these two controls are also connected to the AF IN jack on the rear of the chassis for connecting an external audio oscillator, phone patch, etc. NOTE: In order to reduce hum pickup caused by chassis currents, the cathode and grid return circuits of V1A are grounded at the microphone connectors only. If the AF chassis power plug is removed, resistance checks from the grid and cathode circuits to ground will indicate an open circuit.

#### PLUGIN AUDIO LIMITER MODULE:

The arm of the MIC GAIN potentiometer goes to the grid of the triode section of 6UB V4A, located on the Audio Limiter plug-in module. Speech limiting takes place in the plate circuit by utilizing a pair of battery biased IN100A diodes connected as a full wave shunt rectifier, which limits the output to about 1.4 volts. The diode return circuit goes through the primary of an audio transformer to drive the pentode amplifier. Some of the output voltage is fed back to the triode grid to obtain inverse feedback, which begins when the diodes start to conduct. Application of inverse feedback considerably reduces the distortion generated by the diodes in the plate circuit.

V4B, the pentode section of the 6UB reflex amplifier operates the LIMITER indicator. Some of the output voltage is rectified by a IN95 diode, lightly filtered and applied as positive low frequency pulses to the grid circuit. By this means the sensitivity is greatly increased at the lower speech levels and the low frequency pulses are responsible for the "flicker" in the indicator at the point where limiting begins.

100V

5/5/59 Rev. 9/1/59  
Printed in USA

D Page 18

The ADJ. LIMITER IND. potentiometer, which is accessible through the top of the can, controls the gain of this stage. If the module should become inoperative for any reason, temporary operation may be resumed by removing the module and installing a jumper between pins 2 and 6 on the socket.

#### PLUGIN AUDIO FILTER MODULE:

This module contains two bridged T networks and six full T networks. Each section of 6U8, V6, is used as an amplifier to provide a constant level between the input and output terminals. BT1 is a high pass audio filter and BT2 is a low pass audio filter. T1 and T2 are inserted in an inverse feedback loop between the plate and grid circuits of V6B and are "peaking" circuits at 4000 and 200 cycles, respectively. T3, T4, T5 and T6 are rejection circuits at 7000, 60, 5200 and 90 cycles. This combination of 8 networks provides a steep sided band pass filter between 200 and 3500 cycles which is devoid of dynamic "ringing" distortion inherent in torroid, crystal or mechanical filters. In addition to reducing the distortion products generated by the Inverse Limiter and narrowing the bandwidth of all types of phone emission, the filter greatly attenuates speech components which fall beyond the effective range of the audio frequency phase shift network. By this means the sideband suppression is maintained at -50 db. throughout the normal voice range, in spite of the large degree of speech limiting.

If the Audio Filter module should become inoperative for any reason, temporary operation may be resumed by removing the module and installing a jumper between pins 2 and 5 on the socket. CAUTION: With the Audio Filter removed and terminals jumpered, the SPEECH LEVEL must be reduced to the point where the Limiter Indicator does not operate, to avoid transmitting an unnecessarily broad signal.

The 100V may be operated with both modules removed by installing a jumper between pin 2 of the Audio Limiter socket and pin 5 of the AUDIO FILTER socket.

#### VOX AMPLIFIER AND VOX RECTIFIER:

The Vox Amplifier amplifies the voice signal so that it may be used to operate the Vox relay. The triode section of a 6J5A and one half of a 12AT7 are used, V1A and V3A. The output is rectified by one half 6AL5 Vox Rectifier V5 and this positive voltage operates the grid of the Relay Control tube.



#### QT AMPLIFIER AND QT RECTIFIER:

The purpose of the QT Amplifier is to prevent loudspeaker signals which are picked up by the microphone from operating the VOX relay. Both sections of 12AT7 V2 amplify the voltage from the receiver output transformer which is applied to  $\frac{1}{2}$  6AL5 QT Rectifier, V5. This negative blocking bias is connected in series with the plate return of the VOX Rectifier and prevents rectification in the Vox Rectifier. When the gain of the two amplifier systems is correctly proportioned, loudspeaker signals will not operate the VOX relay. Refer to the Simplified Schematic of VOX and QT circuits.

#### RELAY CONTROL:

The VOX relay in the plate circuit of Relay Control tube V3B,  $\frac{1}{2}$  12AT7, is adjusted to operate at 3.5 to 4.2 ma. and release at 2.5 to 3 ma.

In the STANDBY position of the FUNCTION switch, the grid of the tube is returned to ground while the cathode bias resistor and bleeder limit the plate current to a value such that the relay will not operate.

In the VOX position the grid is connected to the output of the Vox Rectifier. When the output of the Vox Rectifier reaches the proper positive value, sufficient plate current will flow to operate the relay.

When the CALIBRATE switch is in the VOICE position, the cathode circuit of the Relay Control tube is opened to prevent the voice from operating the relay.

For PTT (Push-to-Talk) the grid is connected to a voltage divider network that applies negative 20 volts with the key (or switch) open, and positive 25 volts with the key closed. Application of the negative voltage to the grid while the key is open provides a faster relay release time for high speed keying.

In the MANUAL position, the grid is returned to a point on the cathode resistor network that provides the proper bias to energize the relay.

#### AUDIO PHASE INVERTER:

The Audio Phase Inverter, 12AT7 V7, is driven by the output of the Audio Filter. A generous amount of inverse feedback is used to assure long term stability. By adjustment of the AF RATIO potentiometer in the cathode of the output section, equal voltages are obtained to the input of the audio phase shift network.

## PS-2 DIFFERENTIAL AUDIO PHASE SHIFT NETWORK:

The PS-2 is designed to provide 50 db. of sideband suppression in the range of 200 to 3800 cycles. Insertion loss of this network is approximately 19 db. To compensate for variations in output load circuit tube and wiring capacitances, each output circuit of the PS-2 has been designed with approximately 20 mmfd. less capacity than required. In addition to the circuit capacitances, each terminal (#4 and #8) is externally shunted to ground with a small capacitor to bring the total up to the required value. Audio output voltages of the network are equal in magnitude and have a phase difference of  $90^\circ$

## AF AMPLIFIER AND MODULATOR:

The two  $90^\circ$  audio phase shifted voltages from the network are labeled  $\phi A$  and  $\phi B$  for identification. Each phase is followed by two stages of triode amplification with 12AT7 V8 and 12AT7 V9. Each phase is applied to the grids of the AF Modulator, 12BH7 V10, which operates as a cathode follower. Approximately 35 db. of inverse feedback is applied around each amplifier to insure low distortion, long term balance, and to minimize post-phasing distortion. Modulator tubes may be changed without affecting the sideband suppression. The largest portion of the inverse feedback is obtained by introducing some of the voltage from the Modulator cathodes back to the cathodes of V8.

Each cathode follower plate circuit has a low value plate resistor. Since the plate resistors of V8 and V9 derive their plate voltage from the plate of V10, rather than from the B supply, a small amount of negative feedback is applied from V10 to V9, and an equal amount of positive feedback is applied from V10 to V8. This arrangement stabilizes each phase channel, decouples the individual stages and decouples  $\phi A$  from  $\phi B$ .

## INTERPRETING SWITCH DRAWINGS:

All switches are drawn as viewed from the rear. Section 1 is nearest the front panel. Section 2 is the second wafer from the front panel, etc. The letters F and R signify Front and Rear, and indicate the side of the wafer on which the contacts are mounted. On all Rear sections, the contacts are shown as solid lines, while all Front sections are shown with dashed lines. Some switch sections have contacts on both sides. For example: Sect. 3F means the third wafer from the front panel, the contacts face the panel and the contacts are drawn as dashed lines.

## EMISSION SWITCH CIRCUITS:

The sections of the EMISSION switch are used in the following circuits:

- Sect. 1R. AF input to Balanced Modulator A.
- Sect. 2R. AF input to Balanced Modulator B.
- Sect. 3R. To arm of Carrier Balance Potentiometer B
- Sect. 4F. Changes audio level when switching to various modes of voice transmission. Activates V11A, 8 mc. Reactance tube in FSK position.
- Sect. 4R. In NULL, grounds arm of Carrier Balance potentiometer B, to remove CW CALIBRATE carrier. In CW and FSK, shorts VOX input. Audio still appears at AF OUT jack.
- Sect. 5F. To VOX input circuit. In CW and FSK, with the key in the MAN-VOX jack, applies keying pulses to VOX input to operate the relay.
- Sect. 5R. Meter switching circuit. In NULL position meter is operated by the output of the Null Amplifier diode. In all other positions, meter is connected to METER SWITCH.
- Sect. 6F. CW-FSK monitor circuit.

## EMISSION SWITCH CIRCUIT DETAILS:

### NULL POSITION

- Sect. 1R. Switches input coupling capacitors of Balanced Modulator A to positive modulator bias.
- Sect. 2R. Switches input coupling capacitors of Balanced Modulator B to positive modulator bias.
- Sect. 3R. Shorts arm of Carrier Balance potentiometer A to ground.
- Sect. 4F. Grounds cathode circuit and activates V19B, Null Amplifier.
- Sect. 4R. Shorts CW Calibrate Level bias line.
- Sect. 5F. Open circuit. (Keying pulses to VOX input; closed on FSK and CW only.)
- Sect. 5R. Applies output of Null Amplifier diode to Meter; opens meter switching circuit.
- Sect. 6F. CW-FSK monitor circuit open. (Closed in CW and FSK only.)

#### LSB POSITION:

- Sect. 1R. Switches input coupling capacitors of Balanced Modulator A to output of AF Modulator audio  $\phi A$ .
- Sect. 2R. Switches input coupling capacitors of Balanced Modulator B to output of AF Modulator audio  $\phi B$ .
- Sect. 3R. Shorts arm of Carrier Balance potentiometer to ground.
- Sect. 4F. Lowers cathode bias and inverse feedback of V7A to obtain standard audio gain for SSB and DSB. (Cathode circuit open on V19B, Null Amplifier, Stage inoperative.)
- Sect. 4K. Calibrate Level not shorted by Sect. 4R. (May be grounded by VOX relay in Transmit, or Calibrate Switch in OFF or VOICE calibrate position.)
- Sect. 5F. Open circuit. (Applies keying pulses to VOX input; closed on FSK and CW only.)
- Sect. 5R. Meter switching circuit normal. Controlled by meter switch only.
- Sect. 6F. CW-FSK monitor circuit open. (Closed in CW and FSK only.)

#### USB POSITION:

- Sect. 1R. Switches input coupling capacitors of Balanced Modulator A to output of AF Modulator audio  $\phi B$ .
- Sect. 2R. Switches input coupling capacitors of Balanced Modulator B to output of AF Modulator audio  $\phi A$ .
- Sect. 3R. Same as LSB.
- Sect. 4F. Same as LSB.
- Sect. 4R. Same as LSB.
- Sect. 5F. Same as LSB.
- Sect. 5R. Same as LSB.
- Sect. 6F. Same as LSB.

#### DSB POSITION:

- Sect. 1R. Switches input coupling capacitors of Balanced Modulator A to output of AF Modulator audio  $\phi A$ .
- Sect. 2R. Switches input coupling capacitors of Balanced Modulator B to positive modulator bias.
- Sect. 3R. Same as LSB.
- Sect. 4F. Same as LSB.
- Sect. 4R. Same as LSB.
- Sect. 5F. Same as LSB.
- Sect. 5R. Same as LSB.
- Sect. 6R. Same as LSB.

#### LSC POSITION:

- Sect. 1R. Switches input coupling capacitors of Balanced Modulator A to output of AF Modulator audio  $\phi A$ . (Same as LSB)
- Sect. 2R. Switches input coupling capacitors of Balanced Modulator B to output of AF Modulator audio  $\phi B$ . (Same as LSB)
- Sect. 3R. Shorts arm of Carrier Balance potentiometer A to arm of AM CARRIER potentiometer. The AM CARRIER potentiometer furnishes a variable positive voltage to unbalance Balanced Modulator A for LSC, USC and AM.
- Sect. 4F. Increases cathode bias and inverse feedback of V7A to obtain lower audio level for LSC, USC, AM and PM.
- Sect. 4R. Same as LSB.
- Sect. 5F. Same as LSB.
- Sect. 5R. Same as LSB.
- Sect. 6F. Same as LSB.

#### USC POSITION:

- Sect. 1R. Switches input coupling capacitors of Balanced Modulator A to output of AF Modulator audio  $\phi B$ . (Same as USB).
- Sect. 2R. Switches input coupling capacitors of Balanced Modulator B to output of AF Modulator audio  $\phi A$ . (Same as USB).
- Sect. 3R. Provides carrier, same as LSC.
- Sect. 4F. Same as LSC.
- Sect. 4R. Same as LSB.
- Sect. 5F. Same as LSB.
- Sect. 5R. Same as LSB.
- Sect. 6F. Same as LSB.

#### AM POSITION:

- Sect. 1R. Switches input coupling capacitors of Balanced Modulator A to output of AF Modulator audio  $\phi A$ . (Same as DSB).
- Sect. 2R. Switches input coupling capacitors of Balanced Modulator B to positive modulator bias. (Same as DSB).
- Sect. 3R. Provides carrier, same as LSC.
- Sect. 4F. Same as LSC.
- Sect. 4R. Same as LSB.
- Sect. 5F. Same as LSB.
- Sect. 5R. Same as LSB.
- Sect. 6F. Same as LSE.

#### FM POSITION:

- Sect. 1R. Switches input coupling capacitors of Balanced Modulator A to positive modulator bias.
- Sect. 2R. Switches input coupling capacitors of Balanced Modulator B to output of AF Modulator audio  $\phi B$ .
- Sect. 3R. Shorts arm of Carrier Balance potentiometer A to arm of CW CARRIER potentiometer. The CW CARRIER potentiometer furnishes a variable positive voltage to unbalance Balanced Modulator A.
- Sect. 4F. Same as LSC.
- Sect. 4R. Same as LSB.
- Sect. 5F. Same as LSB.
- Sect. 5R. Same as LSB.
- Sect. 6F. Same as LSB.

#### CW POSITION:

- Sect. 1R. Switches input coupling capacitors of Balanced Modulator A to positive modulator bias.
- Sect. 2R. Switches input coupling capacitors of Balanced Modulator B to positive modulator bias.
- Sect. 3R. Same as PM.
- Sect. 4F. Same as LSC.
- Sect. 4R. Grounds speech input to VOX amplifier.
- Sect. 5F. Applies keying pulses from CW-MAN-VOX jack to VOX amplifier input when FUNCTION switch is in VOX position.
- Sect. 5R. Same as LSB.
- Sect. 6F. Closes CW-FSK monitor circuit.

#### FSK POSITION:

- Sect. 1R. Same as CW.
- Sect. 2R. Same as CW.
- Sect. 3R. Same as PM.
- Sect. 4F. Closes cathode circuit of V11A 8 mc. Reactance Tube, for FSK operation.
- Sect. 4R. Same as CW.
- Sect. 5F. Applies keying pulses from FSK jacks to VOX amplifier input, when FUNCTION switch is in VOX position.
- Sect. 5R. Same as LSB.
- Sect. 6F. CW-FSK monitor circuit closed, same as CW.

#### BALANCED MODULATOR:

The balanced modulator circuit consists of two independent balanced modulators labeled A and B. Each modulator input is isolated from the modulator DC cathode bias by a pair of 6 microfarad coupling capacitors, which are contained in a plugin assembly marked MOD CAPS. In the event that ageing affects their capacity or leakage, they may easily be removed for replacement. When one or both modulators are disabled for AM, PM, CW or FSK operation, these capacitors are connected to a positive dc voltage source approximately equal to the modulator cathode bias, (positive modulator bias) rather than returning to ground. This minimizes switching transients which would occur when changing mode of operation, due to discharging these large capacitors. The resistance of the Carrier Balance potentiometers is about one fourth that of the total circuit, to facilitate carrier balancing and provide a "bandsread" effect.

The matched germanium modulator diodes are mounted on a plugin assembly to facilitate replacement.

#### 8 MC. CRYSTAL OSCILLATOR AND REACTANCE TUBE:

The pentode section of V11 is used as the 8 mc. master crystal oscillator. The triode section functions as a reactance tube that varies the frequency of the crystal. Frequency shift from 100 to about 900 cycles may be obtained depending on the setting of the cathode control in the triode section. Keying of the reactance tube is accomplished by shorting the 50 volt negative grid bias to ground.

#### 8 MC. RF PHASE SHIFT CIRCUITS:

In order to obtain the differential 90° rf phase shift required for the balanced modulators, one R-L and one L-R circuit is used. One circuit provides a 45° leading voltage, while the other provides a 45° lagging voltage. The inductors are slug tuned, and the output of each circuit is applied to one balanced modulator, resulting in an overall (or differential) 90° RF phase shift between them.

#### NULL AMPLIFIER:

The pentode section of 6EA8 V19 is used as a carrier amplifier, to obtain sufficient sensitivity to read the carrier suppression down more than 50 db. In all EMISSION switch positions except NULL, this stage has a high cathode bias which makes it inoperative. In the NULL position the high bias is removed, the carrier output is rectified by a germanium diode and applied to the meter.

## VFO:

Both the triode and pentode section of 6U8 V17 are used in a two terminal class A oscillator which is self compensating for changes in tube transconductance caused by line voltage fluctuations and ageing. The grids are operated with a regulated positive bias in relation to ground and large values of cathode resistance are used to obtain an actual negative operating grid bias. By proper selection of voltage and resistance values, automatic transconductance control is achieved. For example, if the cathode current should tend to decrease due to low filament voltage, the drop in cathode bias will result in a higher effective positive voltage on the grid, which will maintain the plate current at the original value. These characteristics make it possible to use light coupling to the tuned circuit, thereby minimizing tube capacity and Miller effect (U.S. Patent #2,867,725)

Regulated plate voltage is used on the oscillator, as well as the VFO amplifier, 6CB6 V18.

## VFO BUFFER-DOUBLER:

The pentode section of 6E8 V20B is used as a buffer stage when 6 to 5 mc. output is required and as a frequency doubler for 12 to 10 mc. On all bands except 20 and 10 meters, the 6 to 5 mc. output is applied to the cathode of the First Mixer. On 20 meters the 6 to 5 mc. output is fed to the cathode of the Second Mixer, while on 10 meters 12 to 10 mc. is applied to the cathode of the Second Mixer. Separate output couplers are used for each frequency range.

In the XTL position, the VFO-XTL switch changes the screen and control grid of V20B to a triode Pierce crystal oscillator.

In the Standby position, negative 120 volts is used to bias the control grid to cutoff when the XTAL-VFO switch is in the VFO position. In the XTAL position, no blocking bias is applied and the crystal oscillates continuously.

A Slate colored test prod jack is available on top of the chassis for measurement of the dc and rf voltages appearing at the control grid of V20B.

## HIGH FREQUENCY CRYSTAL OSCILLATOR:

V19A, the triode section of a 6E8 is used in a conventional crystal oscillator circuit in which the crystal is connected between grid and ground and the plate circuit is tuned to the desired overtone frequency. Small variable trimmer capacitors are used across the crystals to obtain exact frequency calibration. The output of this stage is applied to either the cathode of the First Mixer or the cathode of the Second Mixer, depending upon the band in use. This oscillator operates continuously, to avoid instability and keying chirp.

100V

5/5/59 Rev. 1/13/60  
Printed in USA



## FIRST MIXER:

The 50 ohm rf output of the Balanced Modulator is fed through the POWER OUTPUT control to the coil marked 8 MC SB GEN TO MIXER, where the impedance is transformed to 5000 ohms and connected to the First Mixer grid. On all amateur bands except 20 and 10 meters the 6 to 5 mc. output of the VFO Buffer-Doubler stage V20B is applied to the cathode of V12. For 20 meter operation 27.5 mc. crystal controlled cathode injection is used, while on 10 meters 47.7 mc. is used. On these two bands, the output of the VFO Buffer-Doubler is applied to the cathode of the Second Mixer.

In the 100V, plugin coil assemblies are labeled according to the plate circuit in which the assembly is used. For example, Second Mixer indicates that the assembly contains the plate coils for the second mixer and the grid coils for the following stage.

The First Mixer plate and Second Mixer grid circuits are tuned as follows on the amateur bands:

160M	14-13 mc. broad band
80M	14-13 mc. broad band
40M	14-13 mc. broad band
20M	19.5 mc. narrow band
15M	14-13 mc. broad band
10M	39.7 mc. narrow band

Four tuned circuits (two separate assemblies cascaded) are used in the 14-13 mc. broad band range to obtain steep sided skirt selectivity.

In the standby position negative 100 volts is used to bias the control grid of the First Mixer to cutoff, on 15, 40, 80 and X bands.

Two test prod jacks are available on top of the chassis for measuring the dc and rf voltages at the grid (red) and cathode (blue).

## SECOND MIXER:

Plugin broadband couplers are used in the plate circuit of the Second Mixer 12BY7 V13, and are tuned to the operating frequency. The following cathode injection frequencies are used for the amateur bands:

160M	15.5 mc. crystal controlled
80M	17.5 mc. crystal controlled
40M	20.5 mc crystal controlled
20M	6-5 mc. VFO
15M	34.5 mc. crystal controlled
10M	12-10 mc. (VFO times 2)

In the standby position negative 100 volts is used to bias the control grid to cutoff, on 10 and 20 meters only.

Two test prod jacks are available on top of the chassis for measuring the dc and rf voltages at the grid (black) and cathode (green).

#### RF DRIVER:

The RF Driver 6BQ5 V14 is an ultralinear beam power amplifier designed to furnish a large amount of class A power with low distortion as compared to other tubes in the same plate dissipation class (12 watts). This stage is neutralized by means of a capacitive divider between the plate of the tube, the grid return circuit, and ground. A negative operating bias of approximately 14 volts is obtained from a voltage divider across the negative 100 volt dc supply. Plugin Broadband rf couplers are used in the plate circuit.

In the Standby position, negative 100 volts dc is used to bias the control grid to cutoff.

Two test prod jacks are available on the top of the chassis for measuring the dc and rf voltages at the grid (orange) or the dc cathode (yellow) current. The dc voltage drop across a 10 ohm bypassed cathode resistor can be used to determine the cathode current.  $I = E/R$ , therefore .40 volts would indicate 40 milliamperes of cathode current, etc.

#### RF POWER AMPLIFIER:

Two ultra linear 6550 beam power tubes, V15 and V16, are connected in parallel and furnish 100 watts of class AB1 rf power output with low distortion. This stage is neutralized by means of a capacitive divider between the plate, the grid return circuit and ground. To eliminate the possibility of parasitic oscillation, 15 ohm carbon resistors are used in series with each grid, and parasitic suppressors are used in series with each plate. The broadband 6550 plate couplers are plugin. A negative operating bias of approximately 39 volts is obtained from a voltage divider across the negative 100 volt dc supply. When the screen current becomes excessive due to a serious mismatch in the output load circuit, resulting from high SWR, an open or shorted antenna circuit, the contacts of the relay will intermittently apply negative 100 volts blocking bias to the 6550's. At this time the neon MISMATCH indicator will light and the relay will provide an audible alarm.

In the Standby position, negative 100 volts is used to bias the control grids to cutoff. A white test prod jack is available on top of the chassis for measuring the dc and rf voltages appearing at the control grids. The voltage drop across a cathode resistance of  $\frac{1}{2}$  ohm (two 1 ohm resistors in parallel) is used for operating the WATTS INPUT scale on the meter. An adjustable rheostat labeled WATTS IN is used for meter calibration.

#### NEUTRALIZING THE POWER AMPLIFIER:

CAUTION: DANGEROUS HIGH VOLTAGES are present on the band-switch, coils and other components underneath the chassis, as well as the bleeder resistors in the 6550 compartment. Use extreme caution when working near exposed wiring.

Should re-neutralization be required, turn the POWER OFF and allow the filter capacitors to discharge. Remove the small 4 prong Amphenol plug located underneath the chassis on the vertical shield between the 6550 plate coils and the low level rf section.

A sensitive rf indicating device, such as a bypassed 0-1 milliammeter in series with a diode should be connected in series with the center conductor of the S0239 rf output receptacle and ground.

With the FUNCTION switch on MANUAL, the BAND switch on 10 meters and the EMISSION switch on CW (with full carrier inserted) adjust the 6550 NEUT capacitor for minimum rf output. Be sure the Amphenol plug is removed, otherwise the meter will become damaged.

After neutralization, turn the POWER OFF, allow the filter capacitors to discharge, and insert the plug into the socket again. Be sure to remove the meter from the output circuit and connect the load circuit before applying power again.

#### RF AMPS SAMPLING CIRCUIT:

The voltage drop across a resistance of 1.25 ohms (eight 10 ohm resistors in parallel) in series with the output coaxial cable is rectified, filtered and applied to the meter to read rf AMPS. An adjustable rheostat labeled AMPS CUT is used to calibrate this meter scale.

### 8 MC. AMPLIFIER:

V21A, the triode section of a 6U8 is used as an 8 mc RF amplifier, and the output is demodulated by a germanium diode to furnish a horizontal sweep audio voltage for the oscilloscope. The output impedance of the Balanced Modulator is approximately 50 ohms, and at this impedance the rf voltage is quite low, about 0.1 volt. To obtain a higher rf voltage, connection is made to the control grid of the First Mixer, where the 50 ohm output of the Balanced Modulator has been transformed to a higher impedance.

### HORIZONTAL AMPLIFIER:

V21B, the pentode section of a 6U8 amplifies the output of the 8 mc. demodulator, which is applied to the horizontal plates of the oscilloscope. The SCOPE WIDTH potentiometer, connected in the control grid circuit, is located at the rear of the low level rf chassis and is used to obtain the desired pattern width.

### 2 INCH MONITORING OSCILLOSCOPE:

The 2 inch cathode ray tube V22 provides a visual check of the linearity of all stages from the Balanced Modulator to the rf output receptacle.

The rf output of the Balanced Modulator is demodulated, amplified and applied to the horizontal plates of the cathode ray tube. The rf output from the 6S50 Power Amplifier is capacitively coupled to the vertical plates. A trapezoid pattern will be displayed in all speech positions except PM, where only a vertical line is furnished.

In the Standby position, negative 100 volts is applied to G1 (intensity grid) to remove the pattern from the screen.

### CALIBRATE LEVEL CIRCUIT:

When the Calibrate switch is in either VOICE or CARRIER position, the CALIBRATE LEVEL potentiometer will vary the blocking bias from negative 70 volts down to zero, to provide a signal in the receiver for frequency spotting.

VOICE calibration allows you to "talk yourself on frequency" on SSB and DSB by slowly tuning the VFO until your voice sounds natural in the receiver. When the CALIBRATE switch is in the VOICE position, speech will not energize the VOX relay.

In CARRIER calibrate, only the modulator system is disabled and a small fixed positive bias is applied to Balanced Modulator B to furnish calibrating carrier regardless of the type of emission. Speech will energize the VOX relay. When the relay is energized, relay contacts 6 and 7 (ground) will open and restore the speech to the audio modulator system, while contacts 7 (ground) and 8 will close and remove the positive bias from Balanced Modulator B to restore the original carrier suppression. If the Calibrate switch is left in the CARRIER position, the calibrate carrier will not appear in the output while transmitting suppressed carrier types of emission.

TUBE COMPLIMENT:

V1A	6U8	(T)	VOX Amplifier
V1B	6U8	(P)	Microphone Preamplifier
V2A	12AT7		QT Amplifier
V2B	12AT7		QT Amplifier
V3A	12AT7		VOX Amplifier
V3B	12AT7		Relay Control
V4A	6U8	(T)	Inverse Limiter
V4B	6U8	(P)	Reflex Amplifier for Limiter Indicator
V5	6AL5		VOX and QT Rectifier
V6A	6U8	(T)	AF Amplifier (AF Filter)
V6B	6U8	(P)	AF Amplifier (AF Filter)
V7A	12AT7		Audio Phase Inverter
V7B	12AT7		Audio Phase Inverter
V8A	12AT7		AF Amplifier
V8B	12AT7		AF Amplifier
V9A	12AT7		AF Amplifier
V9B	12AT7		AF Amplifier
V10A	12BH7		AF Modulator (Cath. Follower)
V10B	12BH7		AF Modulator (Cath. Follower)
V11A	6U8	(T)	8 MC Reactance Tube
V11B	6U8	(P)	8 MC Crystal Oscillator
V12	12BY7		First Mixer
V13	12BY7		Second Mixer
V14	6BQ5		RF Driver
V15	6550		RF Power Amplifier
V16	6550		RF Power Amplifier
V17A	6U8	(T)	VFO Oscillator 6-5 MC
V17B	6U8	(P)	VFO Oscillator 6-5 MC
V18	6CB6		VFO Amplifier 6-5 MC
V19A	6EA8	(T)	H.F. Crystal Oscillator
V19B	6EA8	(P)	Null Amplifier (Carrier)
V20A	6EA8	(T)	Meter Rectifier (Line Voltage)
V20B	6EA8	(P)	VFO Buffer - Doubler
V21A	6U8	(T)	8 MC Amplifier
V21B	6U8	(P)	Horizontal Amplifier
V22	2AP1		Cathode Ray Oscilloscope, 2"
V23	5U4GB		Low Voltage Rectifier
V24	6AU4GTA		High Voltage Rectifier
V25	6AU4GTA		High Voltage Rectifier
V26	0A2		Voltage Regulator

SECTION VIII  
MAINTENANCE AND REPAIR

CAUTION: DANGEROUS HIGH VOLTAGES ARE PRESENT ON THE SWITCHES, ETC. BEHIND THE FRONT PANEL, UNDERNEATH THE SAU4GTA SOCKETS, ON THE LARGE RESISTORS IN THE 6550 SHIELD COMPARTMENT, AS WELL AS COMPONENTS UNDERNEATH THE CHASSIS. USE EXTREME CAUTION WHEN WORKING ANYWHERE ON THIS EQUIPMENT WHEN THE POWER IS ON.

LOW LEVEL BROADBAND RF CIRCUITS:

Most of the low level RF circuits are broad-banded and aligned with an RF sweep generator and oscilloscope at the factory. DO NOT PEAK OR ADJUST THESE CIRCUITS WITHOUT THE PROPER TEST EQUIPMENT. Detailed alignment instructions are available upon special request. Please submit a list of test equipment you have available.

These broadband circuits include the Buffer-Doubler, Driver, Second Mixer, and First Mixer (except 19.5 mc for 20 meters and 39.7 mc for 10 meters which are normally slightly detuned to equalize their gain with respect to other bands). The high frequency XTAL OSC slugs may be adjusted for maximum output, then frequency calibration. Correct calibration will occur near maximum output. The 8 MC SB GEN. TO MIXER may also be peaked; it is normally detuned at the factory so that when the OUTPUT control is set at 3 o'clock, the final amplifier will be driven to 180 watts input, with a 52 ohm non-inductive load.

REMOVING THE PLUG-IN AUDIO LIMITER, PLUG-IN AUDIO FILTER, OR RELAY COVER:

Press the latching clamp down about 1/8 inch (compressing the rubber) at the end near the VOX RELAY cover, then away from the shield until the hook is disengaged from the slot.

REMOVING THE PS-2:

Remove the Phillips head screw from the bracket on the chassis located between the PS-2 and the power transformer.

FAN MOTOR MAINTENANCE:

Inspect fans for oil hole or oil wick. This type of fan motor should be lubricated periodically with a few drops of light machine oil to prevent them from becoming noisy.

REPLACING DEFECTIVE SECTIONS IN THE BANDSWITCH:

Bandswitch sections may be changed without disassembling any of the adjacent sections. Obtain two rods 1/8" diameter about 15" long. In an emergency, the straight sections of wire coat hangers may be used.

1. Remove the wires from the defective section.
2. Open the right panel door and remove the chains from their sprockets.
3. Remove the four screws that fasten the rectangular bandswitch mounting plate to the front of the chassis.

4. At the rear of the switch, remove the two 5-40 nuts and lock-washers.
5. Insert the two 1/8" diameter rods through the holes in the rear of the chassis and use them to push the two long 5-40 band-switch frame screws out towards the front panel. Use equal pressure on both rods. This will push the mounting plate, indexing assembly and shaft out through the opening in the front panel. Push the rods just beyond the defective wafer, then back slightly until the wafer can be removed.
6. When pushing the plate and indexing assembly back in, be sure that the grounding spring engages the shaft at the shield between the low level rf section and the output coils.

#### REMOVING THE VFO:

1. Remove the 100V from the cabinet. Lay the 100V on its left side.
2. Using a screw driver, carefully remove the VFO power plug (6 prong) from the RF chassis.
3. Remove the VFO RF output (white coax) phono plug from the extension receptacle. This receptacle is taped to the wiring harness.
4. Loosen the two screw driver-slot set screws which are located inside the large dial hub, on the rear of the 100KC dial scale. **DO NOT LOOSEN THE TWO ALLEN HEAD SET SCREWS LOCATED ON THE 3/4" DIAMETER SHAFT.**
5. Pull the entire tuning knob assembly out of the front panel housing.
6. Remove the four Phillips Head screws which hold the four square VFO mounting posts to the front panel.
7. Remove the ball-chain from the sprocket on the right side of the drum dial.
8. Slide a large piece of newspaper between the rear of the panel and the calibrated disc and drum dials. This will prevent scratching the dials.
9. Press the lower portion of the clear fiduciary scale flat against the panel, to enable the lower two square posts to clear the fiduciary scale while "rocking" the VFO out of the top of the 100V.

When installing the VFO again, be sure to use newspaper against the back of the panel.



## VFO RECALIBRATION:

When necessary, the VFO can be recalibrated right at the operating position. With the double conversion system used, the VFO is at 6 megacycles for the low frequency end of the band and 5 megacycles for the high frequency end of the band.

Using the 80 meter band (3.5 to 4.5 MC) as an example, we find that:

### FIRST CONVERSION:

$$\begin{array}{r} 8.000 \text{ MC Master generator frequency} \\ \text{plus } 6.000 \text{ MC VFO frequency} \\ \hline 14.000 \text{ MC conversion frequency} \end{array}$$

### SECOND CONVERSION:

$$\begin{array}{r} 17.500 \text{ MC Second conversion crystal} \\ \text{minus } 14.000 \text{ MC First conversion frequency} \\ \hline 3.500 \text{ MC Output frequency (second conversion)} \end{array}$$

and

### FIRST CONVERSION:

$$\begin{array}{r} 8.000 \text{ MC Master generator frequency} \\ \text{plus } 5.000 \text{ MC VFO frequency} \\ \hline 13.000 \text{ MC First conversion frequency} \end{array}$$

### SECOND CONVERSION:

$$\begin{array}{r} 17.500 \text{ MC Second conversion crystal} \\ \text{minus } 13.000 \text{ MC First conversion frequency} \\ \hline 4.500 \text{ MC Output frequency (second conversion)} \end{array}$$

It is suggested that the VFO frequency be checked against WWV at 5 megacycles with the red pointer at the last .1 MC integral marking at the high frequency end of the scale and the kilocycle scale at 0. RF output can be obtained at the "VFO OUT" jack on rear apron.

Remove the plug button nearest to the front panel.

Allow at least 5 minutes for the unit to warm up. Adjust the center screw (second one) for zero beat with WWV or a secondary standard. The left screw (first one) is for 4950 KC. Refer to the 100V TOP VIEW drawing.

At this time it is advisable to check the conversion crystal accuracy by listening to the output frequencies at 4.5, 7.5, 14.5, 21.5 and 29.7 MC and correcting the conversion crystals if necessary.

100V  
5/5/59 Revised 12/16/59  
Printed in USA

Adjust CX1 at 29.7 MC  
 CX2 at 21.5 MC  
 CX3 at 14.5 MC  
 CX4 at 7.5 MC  
 CX5 at 4.5 MC  
 CX6 at 2.5 MC

On all bands except 10 meters the VFO can be corrected every 50 kilocycles if a 50 KC standard is available. If only a 100 KC standard is available, the VFO can be corrected at each 100 KC integral by adjusting the odd screws (3rd, 5th, 7th, etc.), which appear in the slotted opening.

#### DETERMINING THE PROPER CRYSTAL FOR CRYSTAL CONTROLLED OPERATION:

Front Panel Crystal =  $X1-8-Fo$

X1 = Conversion Crystal MC

8 = Master Internal Generator Frequency in MC

Fo = Output Frequency in MC

For frequencies between 25.5 and 29.7 MC, the following formula applies:

Front Panel Crystal =  $\frac{X1-8-Fo}{2}$

#### CONVERSION CRYSTAL FREQUENCIES:

X1 47.7 MC for 28.7 to 29.7 MC  
 X2 34.5 MC for 20.5 to 21.5 MC  
 X3 27.5 MC for 13.5 to 14.5 MC  
 X4 20.5 MC for 6.5 to 7.5 MC  
 X5 17.5 MC for 3.5 to 4.5 MC  
 X6 15.5 MC for 1.5 to 2.5 MC  
 X7 EXTERNAL CRYSTAL  
 X8 3.000 MC MASTER OSCILLATOR

Crystal holders for the 100V must be type HC-6, with .095 diameter pins for FT-243 socket. If larger holders are used, the panel door will not close.

#### ADJUSTING THE TENSION ON THE PLANETARY DRIVE:

Remove the VFO fine tuning knob using the Allen Wrench that is supplied in the accessory bag. Tighten the three screws uniformly, a small amount each time until the desired tension is obtained.

#### VFO LUBRICATION:

In order to reduce friction in the VFO mechanism, the following parts are coated with Dow-Corning #33 Heavy Consistency low temperature silicone grease:

1. Threads of the  $\frac{1}{2}$ -20 lead screw shaft
2. Top of the round  $\frac{3}{8}$ " diameter stainless steel post
3. Bottom of the 2-56 correcting screws

These parts are accessible by removing the bottom cover of the VFO, after removing the VFO from the panel.

## SIDEBAND SUPPRESSION ADJUSTMENT:

Before proceeding with the single sideband adjustments, it is recommended that the operator familiarize himself with the illustrations of the oscilloscope patterns shown in this manual. The ultimate objective in the single sideband alignment is to obtain a pattern containing a minimum amount of ripple when a pure sine wave is applied to the AF INrUT jack. These adjustments should preferably be made at less than full output, to prevent amplifier overloading which might "wipe off" the small amount of modulation ripple.

A low distortion audio oscillator having less than 0.3% distortion should be used at a frequency anywhere between 1000 and 1500 cycles, and the level to the AF IN jack should be less than 1 volt. When the audio oscillator has distortion in excess of 0.3% these distortion products will appear as ripple in the output waveform and can not be balanced out by the adjustments. If this is the case, the only alternative is to adjust for an equal amount of ripple in each sideband. Distortion in the speech amplifier caused by overloading or a defective tube can also produce a similar ripple. Whenever the Central Electronics MM-2 Modulation Analyzer is used as a source for the audio frequency tone be sure to adjust the feedback potentiometer, R57, to the point where oscillation is just sustained in order to keep the distortion to a minimum.

The following four adjustments determine the sideband suppression: the AF RATIO potentiometer, the AF BAL potentiometer, and the two 8 mc RF phase shift coils. Note: If the 8 mc. crystal oscillator plate coil is detuned, or the oscillator output low for any other reason, ripple will appear on the pattern. Before making the adjustments, be sure that the EMISSION switch is in either the USB or LSB position, and the RF POWER OUTPUT control is at maximum.

With the EMISSION switch in the NULL position, adjust the carrier balance potentiometers for minimum carrier output as indicated on the meter. Advance the SPEECH LEVEL control until about two thirds maximum output is obtained on the oscilloscope. At no time should the speech amplifier be driven to the point where the Audio Limiter is operating. If a noticeable amount of ripple is present in the oscilloscope, try adjusting the AF RATIO and AF BAL potentiometers first.

The most satisfactory method of adjustment is to leave the EMISSION switch in the sideband position which indicates the largest amount of ripple, then slowly turn the AF adjustments until the amount of ripple is reduced to half the original value. In other words, try "splitting the difference" each time an adjustment is made and then switch to the opposite sideband and try, if possible, to reduce the ripple again. During the adjustment process it will be necessary to switch sidebands several times. In many cases it will be found that if the ripple is completely eliminated at one time while adjusting one sideband, the other sideband will become worse.

If adequate suppression can not be obtained by varying these two potentiometers, it will be necessary to adjust the RF phase shift. Each time RF phase shift adjustments are made, it will be necessary to re-balance the carrier by setting the EMISSION switch to the NULL position (which also automatically removes the audio signal) and adjust the CARRIER BALANCE controls for minimum. Be sure to switch sidebands frequently during the alignment procedure.

#### SIDEBAND SUPPRESSION ADJUSTMENT WITHOUT THE USE OF A SCOPE:

In an emergency, it is possible to adjust the sideband suppression using only an audio oscillator and a receiver. Only an audio oscillator with low distortion should be used, set to approximately 1000 cycles.

The receiving antenna should be removed, the BFO turned OFF and the AVC ON. Tune in the signal in the receiver.

On the 100V, the Speech Level control should be kept well below the point where the audio limiter begins to operate and the Carrier Balance controls adjusted for MINIMUM carrier at all times.

Remember that with sine wave input, a pure SSB signal has NO modulation ripple and resembles a CW carrier. With the FUNCTION switch on LSB or USB, adjust the AF BAL and AF RATIO potentiometers for MINIMUM modulation in the receiver. Minimum modulation corresponds to maximum sideband suppression. During adjustment, switch sidebands frequently to see that the suppression in both sidebands is improving. If it is necessary to adjust the 8 mc. RF phase shift circuits, be sure to balance out the carrier after each adjustment. Audio or rf unbalance will provide a 2000 cycle tone, while carrier will result in a 1000 cycle tone. It may not be possible to eliminate the modulation entirely due to the distortion in the average audio oscillator.

TUBE VOLTAGE CHART 100W  
 TRANSMITTER IN STANDBY UNLESS  
 OTHERWISE INDICATED. V12-V13-V14-V15  
 ARE BASED OFF OR ON AS NOTED "ON" AT 175 WATTS INPUT

MEASURED WITH  
 M.T.V.M.

TUBE	PIN NO	1	2	3	4	5	6	7	8	9	Function
V1	60	0	108	F	F	167	3.5	20	0	0	AUDIO BUS
V2	99	0	1.7	F	F	135	0	2.1	F	F	OT 12AT7
V3	270	MAX 125 MIN 25	MAX 16 MIN 29	F	F	125	0	2.0	F	F	RELAY 12AT7
V4	160	0	66	F	F	90	2.5	6.5	0	0	LIM BUS
V5	6	VOX MAX -23	F	F	VOX MAX -32	-	VOX MAX -20	-	-	-	VOX BAL 5
V6	132	0	-	F	F	115	3.1	40	-	-	FILTER BUS
V7	120	9	7.5	F	F	122	7.5	12	F	F	OR INV 12AT7
V8	22	.9	1.9	F	F	22	.9	1.9	F	F	AUDIO 12AT7
V9	68	0	14	F	F	68	0	1.4	F	F	12AT7
V10	130	0	4.1	F	F	130	0	4.1	F	F	MOD 12BA7
V11	140	10	114	-	F	135	10.5	18k	ON NORMAL VARIES	ON NORMAL VARIES	5MC XTAL 6EA8
V12	3	-120 STBY 0 ON	115-40-80- GRD	10-20 ON F	15-40-80- ON	F	260	115	GRD	GRD	1ST MIX 12BY7
V13	48	-120 STBY 0 ON	10-20- GRD	15-40-80- ON	ON	F	340	178	GRD	GRD	2ND MIX 12BY7
V14	-120 STBY -45 ON	-120 STBY -15 ON	39	F	F	-	340	-	300	300	DRIVER 6BD5
V15	GRD	F	620	340	-120 STBY 42 ON	-	F	.1	-	-	FINAL 6550
V16	GRD	F	620	340	-120 STBY 42 ON	-	F	.1	-	-	FINAL 6550
V17	150	8	64	F	F	120	11	21	17	17	VFO OSC BUS
V18	0	8	F	F	150	14.4	.8	-	-	-	VFO AMP 6CB6
V19	145	0	66	F	F	145	1	CHOKE TO GRD	-	-	NULL 6EA8 X1L
V20	6.9 AC	126 STBY 10 ON	170	F	F	250	44	32	6.9 AC	6.9 AC	BUF DEL 6EA8
V21	145	1AF	80	F	F	80	2.4	4.5	0	0	SCOPE BUS
V22	111	10	600	170	0 STBY 42 ON	600	600	600	600	600	SCOPE 2AF1
V23	-	340 F	470 OHM	470 OHM	470 AC	-	F	-	-	-	RECT 5U4
V24	-	-	620 K	760 AC	760 AC	-	F	F	-	-	RECT 6AU4
V25	-	-	620 K	760 AC	760 AC	-	F	F	-	-	RECT 6AU4
V26	150	GRD	-	GRD	150	-	GRD	-	-	-	REG 04Z

\* NOTE: PIN 9 ON TUBES 6BD5, 6CB6, 6CA6, 6CA7, 6CA8, 6CA9, 6CA10, 6CA11, 6CA12, 6CA13, 6CA14, 6CA15, 6CA16, 6CA17, 6CA18, 6CA19, 6CA20, 6CA21, 6CA22, 6CA23, 6CA24, 6CA25, 6CA26, 6CA27, 6CA28, 6CA29, 6CA30, 6CA31, 6CA32, 6CA33, 6CA34, 6CA35, 6CA36, 6CA37, 6CA38, 6CA39, 6CA40, 6CA41, 6CA42, 6CA43, 6CA44, 6CA45, 6CA46, 6CA47, 6CA48, 6CA49, 6CA50, 6CA51, 6CA52, 6CA53, 6CA54, 6CA55, 6CA56, 6CA57, 6CA58, 6CA59, 6CA60, 6CA61, 6CA62, 6CA63, 6CA64, 6CA65, 6CA66, 6CA67, 6CA68, 6CA69, 6CA70, 6CA71, 6CA72, 6CA73, 6CA74, 6CA75, 6CA76, 6CA77, 6CA78, 6CA79, 6CA80, 6CA81, 6CA82, 6CA83, 6CA84, 6CA85, 6CA86, 6CA87, 6CA88, 6CA89, 6CA90, 6CA91, 6CA92, 6CA93, 6CA94, 6CA95, 6CA96, 6CA97, 6CA98, 6CA99, 6CA100, 6CA101, 6CA102, 6CA103, 6CA104, 6CA105, 6CA106, 6CA107, 6CA108, 6CA109, 6CA110, 6CA111, 6CA112, 6CA113, 6CA114, 6CA115, 6CA116, 6CA117, 6CA118, 6CA119, 6CA120, 6CA121, 6CA122, 6CA123, 6CA124, 6CA125, 6CA126, 6CA127, 6CA128, 6CA129, 6CA130, 6CA131, 6CA132, 6CA133, 6CA134, 6CA135, 6CA136, 6CA137, 6CA138, 6CA139, 6CA140, 6CA141, 6CA142, 6CA143, 6CA144, 6CA145, 6CA146, 6CA147, 6CA148, 6CA149, 6CA150, 6CA151, 6CA152, 6CA153, 6CA154, 6CA155, 6CA156, 6CA157, 6CA158, 6CA159, 6CA160, 6CA161, 6CA162, 6CA163, 6CA164, 6CA165, 6CA166, 6CA167, 6CA168, 6CA169, 6CA170, 6CA171, 6CA172, 6CA173, 6CA174, 6CA175, 6CA176, 6CA177, 6CA178, 6CA179, 6CA180, 6CA181, 6CA182, 6CA183, 6CA184, 6CA185, 6CA186, 6CA187, 6CA188, 6CA189, 6CA190, 6CA191, 6CA192, 6CA193, 6CA194, 6CA195, 6CA196, 6CA197, 6CA198, 6CA199, 6CA200, 6CA201, 6CA202, 6CA203, 6CA204, 6CA205, 6CA206, 6CA207, 6CA208, 6CA209, 6CA210, 6CA211, 6CA212, 6CA213, 6CA214, 6CA215, 6CA216, 6CA217, 6CA218, 6CA219, 6CA220, 6CA221, 6CA222, 6CA223, 6CA224, 6CA225, 6CA226, 6CA227, 6CA228, 6CA229, 6CA230, 6CA231, 6CA232, 6CA233, 6CA234, 6CA235, 6CA236, 6CA237, 6CA238, 6CA239, 6CA240, 6CA241, 6CA242, 6CA243, 6CA244, 6CA245, 6CA246, 6CA247, 6CA248, 6CA249, 6CA250, 6CA251, 6CA252, 6CA253, 6CA254, 6CA255, 6CA256, 6CA257, 6CA258, 6CA259, 6CA260, 6CA261, 6CA262, 6CA263, 6CA264, 6CA265, 6CA266, 6CA267, 6CA268, 6CA269, 6CA270, 6CA271, 6CA272, 6CA273, 6CA274, 6CA275, 6CA276, 6CA277, 6CA278, 6CA279, 6CA280, 6CA281, 6CA282, 6CA283, 6CA284, 6CA285, 6CA286, 6CA287, 6CA288, 6CA289, 6CA290, 6CA291, 6CA292, 6CA293, 6CA294, 6CA295, 6CA296, 6CA297, 6CA298, 6CA299, 6CA300, 6CA301, 6CA302, 6CA303, 6CA304, 6CA305, 6CA306, 6CA307, 6CA308, 6CA309, 6CA310, 6CA311, 6CA312, 6CA313, 6CA314, 6CA315, 6CA316, 6CA317, 6CA318, 6CA319, 6CA320, 6CA321, 6CA322, 6CA323, 6CA324, 6CA325, 6CA326, 6CA327, 6CA328, 6CA329, 6CA330, 6CA331, 6CA332, 6CA333, 6CA334, 6CA335, 6CA336, 6CA337, 6CA338, 6CA339, 6CA340, 6CA341, 6CA342, 6CA343, 6CA344, 6CA345, 6CA346, 6CA347, 6CA348, 6CA349, 6CA350, 6CA351, 6CA352, 6CA353, 6CA354, 6CA355, 6CA356, 6CA357, 6CA358, 6CA359, 6CA360, 6CA361, 6CA362, 6CA363, 6CA364, 6CA365, 6CA366, 6CA367, 6CA368, 6CA369, 6CA370, 6CA371, 6CA372, 6CA373, 6CA374, 6CA375, 6CA376, 6CA377, 6CA378, 6CA379, 6CA380, 6CA381, 6CA382, 6CA383, 6CA384, 6CA385, 6CA386, 6CA387, 6CA388, 6CA389, 6CA390, 6CA391, 6CA392, 6CA393, 6CA394, 6CA395, 6CA396, 6CA397, 6CA398, 6CA399, 6CA400, 6CA401, 6CA402, 6CA403, 6CA404, 6CA405, 6CA406, 6CA407, 6CA408, 6CA409, 6CA410, 6CA411, 6CA412, 6CA413, 6CA414, 6CA415, 6CA416, 6CA417, 6CA418, 6CA419, 6CA420, 6CA421, 6CA422, 6CA423, 6CA424, 6CA425, 6CA426, 6CA427, 6CA428, 6CA429, 6CA430, 6CA431, 6CA432, 6CA433, 6CA434, 6CA435, 6CA436, 6CA437, 6CA438, 6CA439, 6CA440, 6CA441, 6CA442, 6CA443, 6CA444, 6CA445, 6CA446, 6CA447, 6CA448, 6CA449, 6CA450, 6CA451, 6CA452, 6CA453, 6CA454, 6CA455, 6CA456, 6CA457, 6CA458, 6CA459, 6CA460, 6CA461, 6CA462, 6CA463, 6CA464, 6CA465, 6CA466, 6CA467, 6CA468, 6CA469, 6CA470, 6CA471, 6CA472, 6CA473, 6CA474, 6CA475, 6CA476, 6CA477, 6CA478, 6CA479, 6CA480, 6CA481, 6CA482, 6CA483, 6CA484, 6CA485, 6CA486, 6CA487, 6CA488, 6CA489, 6CA490, 6CA491, 6CA492, 6CA493, 6CA494, 6CA495, 6CA496, 6CA497, 6CA498, 6CA499, 6CA500, 6CA501, 6CA502, 6CA503, 6CA504, 6CA505, 6CA506, 6CA507, 6CA508, 6CA509, 6CA510, 6CA511, 6CA512, 6CA513, 6CA514, 6CA515, 6CA516, 6CA517, 6CA518, 6CA519, 6CA520, 6CA521, 6CA522, 6CA523, 6CA524, 6CA525, 6CA526, 6CA527, 6CA528, 6CA529, 6CA530, 6CA531, 6CA532, 6CA533, 6CA534, 6CA535, 6CA536, 6CA537, 6CA538, 6CA539, 6CA540, 6CA541, 6CA542, 6CA543, 6CA544, 6CA545, 6CA546, 6CA547, 6CA548, 6CA549, 6CA550, 6CA551, 6CA552, 6CA553, 6CA554, 6CA555, 6CA556, 6CA557, 6CA558, 6CA559, 6CA560, 6CA561, 6CA562, 6CA563, 6CA564, 6CA565, 6CA566, 6CA567, 6CA568, 6CA569, 6CA570, 6CA571, 6CA572, 6CA573, 6CA574, 6CA575, 6CA576, 6CA577, 6CA578, 6CA579, 6CA580, 6CA581, 6CA582, 6CA583, 6CA584, 6CA585, 6CA586, 6CA587, 6CA588, 6CA589, 6CA590, 6CA591, 6CA592, 6CA593, 6CA594, 6CA595, 6CA596, 6CA597, 6CA598, 6CA599, 6CA600, 6CA601, 6CA602, 6CA603, 6CA604, 6CA605, 6CA606, 6CA607, 6CA608, 6CA609, 6CA610, 6CA611, 6CA612, 6CA613, 6CA614, 6CA615, 6CA616, 6CA617, 6CA618, 6CA619, 6CA620, 6CA621, 6CA622, 6CA623, 6CA624, 6CA625, 6CA626, 6CA627, 6CA628, 6CA629, 6CA630, 6CA631, 6CA632, 6CA633, 6CA634, 6CA635, 6CA636, 6CA637, 6CA638, 6CA639, 6CA640, 6CA641, 6CA642, 6CA643, 6CA644, 6CA645, 6CA646, 6CA647, 6CA648, 6CA649, 6CA650, 6CA651, 6CA652, 6CA653, 6CA654, 6CA655, 6CA656, 6CA657, 6CA658, 6CA659, 6CA660, 6CA661, 6CA662, 6CA663, 6CA664, 6CA665, 6CA666, 6CA667, 6CA668, 6CA669, 6CA670, 6CA671, 6CA672, 6CA673, 6CA674, 6CA675, 6CA676, 6CA677, 6CA678, 6CA679, 6CA680, 6CA681, 6CA682, 6CA683, 6CA684, 6CA685, 6CA686, 6CA687, 6CA688, 6CA689, 6CA690, 6CA691, 6CA692, 6CA693, 6CA694, 6CA695, 6CA696, 6CA697, 6CA698, 6CA699, 6CA700, 6CA701, 6CA702, 6CA703, 6CA704, 6CA705, 6CA706, 6CA707, 6CA708, 6CA709, 6CA710, 6CA711, 6CA712, 6CA713, 6CA714, 6CA715, 6CA716, 6CA717, 6CA718, 6CA719, 6CA720, 6CA721, 6CA722, 6CA723, 6CA724, 6CA725, 6CA726, 6CA727, 6CA728, 6CA729, 6CA730, 6CA731, 6CA732, 6CA733, 6CA734, 6CA735, 6CA736, 6CA737, 6CA738, 6CA739, 6CA740, 6CA741, 6CA742, 6CA743, 6CA744, 6CA745, 6CA746, 6CA747, 6CA748, 6CA749, 6CA750, 6CA751, 6CA752, 6CA753, 6CA754, 6CA755, 6CA756, 6CA757, 6CA758, 6CA759, 6CA760, 6CA761, 6CA762, 6CA763, 6CA764, 6CA765, 6CA766, 6CA767, 6CA768, 6CA769, 6CA770, 6CA771, 6CA772, 6CA773, 6CA774, 6CA775, 6CA776, 6CA777, 6CA778, 6CA779, 6CA780, 6CA781, 6CA782, 6CA783, 6CA784, 6CA785, 6CA786, 6CA787, 6CA788, 6CA789, 6CA790, 6CA791, 6CA792, 6CA793, 6CA794, 6CA795, 6CA796, 6CA797, 6CA798, 6CA799, 6CA800, 6CA801, 6CA802, 6CA803, 6CA804, 6CA805, 6CA806, 6CA807, 6CA808, 6CA809, 6CA810, 6CA811, 6CA812, 6CA813, 6CA814, 6CA815, 6CA816, 6CA817, 6CA818, 6CA819, 6CA820, 6CA821, 6CA822, 6CA823, 6CA824, 6CA825, 6CA826, 6CA827, 6CA828, 6CA829, 6CA830, 6CA831, 6CA832, 6CA833, 6CA834, 6CA835, 6CA836, 6CA837, 6CA838, 6CA839, 6CA840, 6CA841, 6CA842, 6CA843, 6CA844, 6CA845, 6CA846, 6CA847, 6CA848, 6CA849, 6CA850, 6CA851, 6CA852, 6CA853, 6CA854, 6CA855, 6CA856, 6CA857, 6CA858, 6CA859, 6CA860, 6CA861, 6CA862, 6CA863, 6CA864, 6CA865, 6CA866, 6CA867, 6CA868, 6CA869, 6CA870, 6CA871, 6CA872, 6CA873, 6CA874, 6CA875, 6CA876, 6CA877, 6CA878, 6CA879, 6CA880, 6CA881, 6CA882, 6CA883, 6CA884, 6CA885, 6CA886, 6CA887, 6CA888, 6CA889, 6CA890, 6CA891, 6CA892, 6CA893, 6CA894, 6CA895, 6CA896, 6CA897, 6CA898, 6CA899, 6CA900, 6CA901, 6CA902, 6CA903, 6CA904, 6CA905, 6CA906, 6CA907, 6CA908, 6CA909, 6CA910, 6CA911, 6CA912, 6CA913, 6CA914, 6CA915, 6CA916, 6CA917, 6CA918, 6CA919, 6CA920, 6CA921, 6CA922, 6CA923, 6CA924, 6CA925, 6CA926, 6CA927, 6CA928, 6CA929, 6CA930, 6CA931, 6CA932, 6CA933, 6CA934, 6CA935, 6CA936, 6CA937, 6CA938, 6CA939, 6CA940, 6CA941, 6CA942, 6CA943, 6CA944, 6CA945, 6CA946, 6CA947, 6CA948, 6CA949, 6CA950, 6CA951, 6CA952, 6CA953, 6CA954, 6CA955, 6CA956, 6CA957, 6CA958, 6CA959, 6CA960, 6CA961, 6CA962, 6CA963, 6CA964, 6CA965, 6CA966, 6CA967, 6CA968, 6CA969, 6CA970, 6CA971, 6CA972, 6CA973, 6CA974, 6CA975, 6CA976, 6CA977, 6CA978, 6CA979, 6CA980, 6CA981, 6CA982, 6CA983, 6CA984, 6CA985, 6CA986, 6CA987, 6CA988, 6CA989, 6CA990, 6CA991, 6CA992, 6CA993, 6CA994, 6CA995, 6CA996, 6CA997, 6CA998, 6CA999, 6CA1000.

\* ONLY APPLY WHEN SET HAS 6A-POWER SUPPLIED IN SET # 230

R.F. VOLTAGE CHART 100V  
 VTVM WITH R.F. PROBE  
 TYPICAL READINGS, R.M.S.  
 READINGS, RMS

BAND	(1ST MIXER)	(2ND MIXER)	(DRIVER 6BQ5)	(6550 S DOUBLER)	(VFO)	(BUFFER)			
	TP	TP	TP	TP	TP	TP	TP	TP	TP
	RED GRID	BLUE CATHODE	BLACK GRID	GREEN CATHODE	ORANGE GRID	YELLOW CATHODE	WHITE GRID	SLATE GRID	BROWN GRID
X	1.0	x	x	x	x	x	x	x	x
80	11	18 VFO	28	15 XTL	68	.5	33	10	.5
40	11	18 VFO	27	16 XTL	89	.6	34	10	.5
20	11	25 XTL	35	21 VFO	11	.8	33	10	.5
15	11	21 VFO	28	17 XTL	11	.8	33	10	.5
10	11	20 XTL	32	18 VFO	10	.9	30	10	.5

NOTE

X BAND WHEN FURNISHED HAS SAME TYPICAL READINGS  
 EXTERNAL XTL. WILL READ TP SLATE EQUAL (JE10)

SIMPLIFIED SCHEMATIC OF VOX & QT CIRCUITS

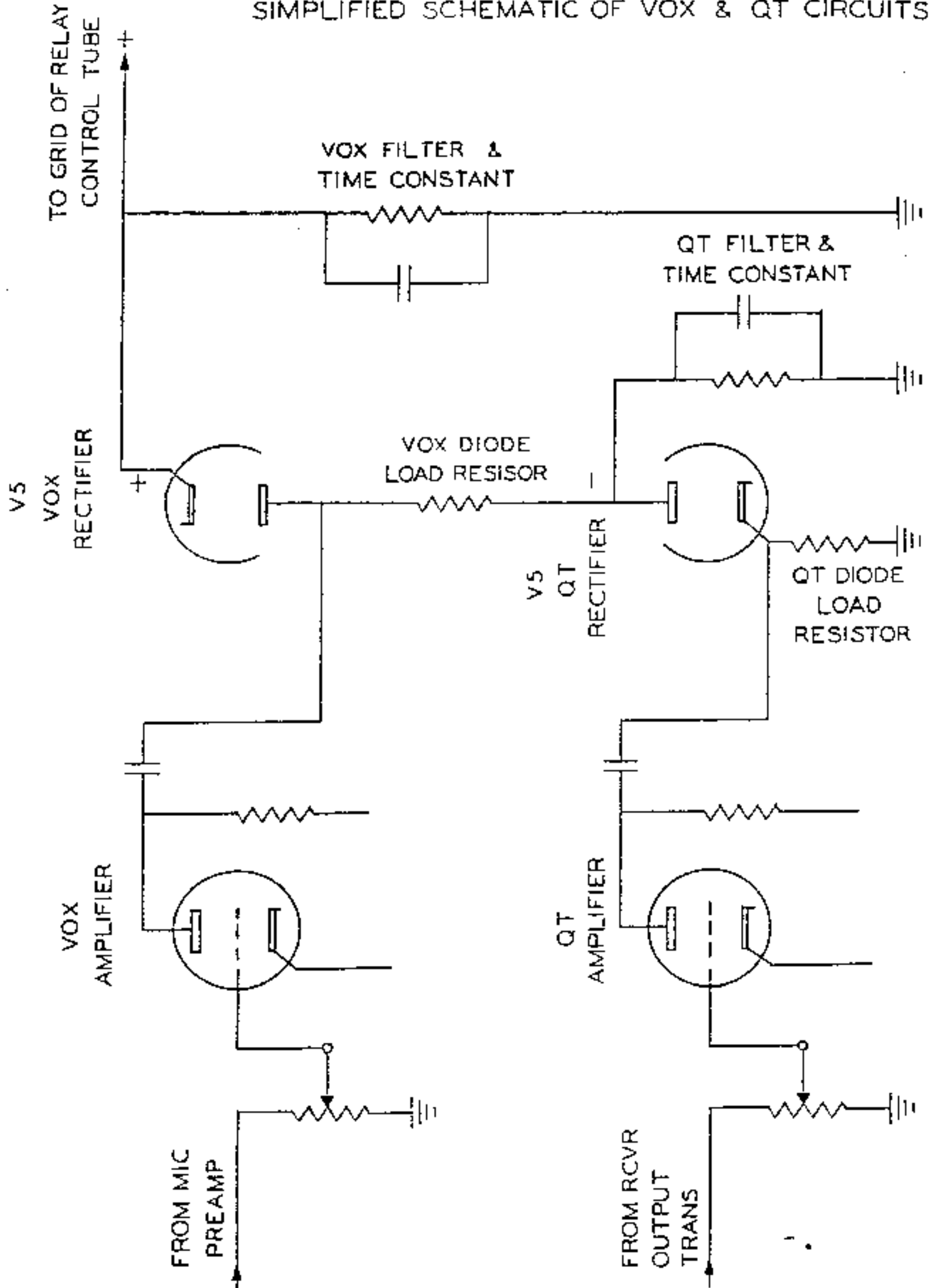



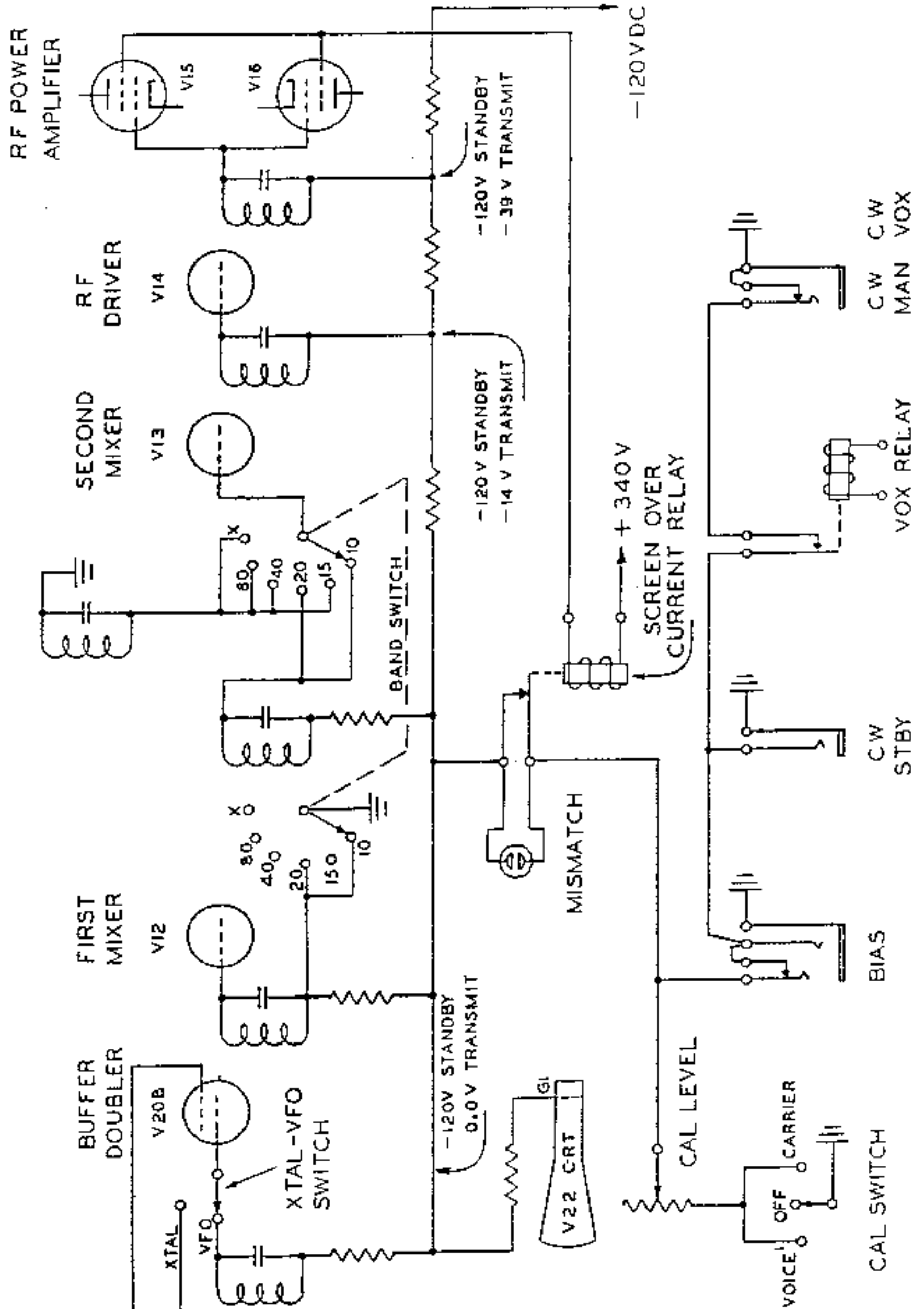

MODEL 100V... SIMPLIFIED BLOCKING BIAS OPERATING BIAS & CALIBRATE CIRCUITS.

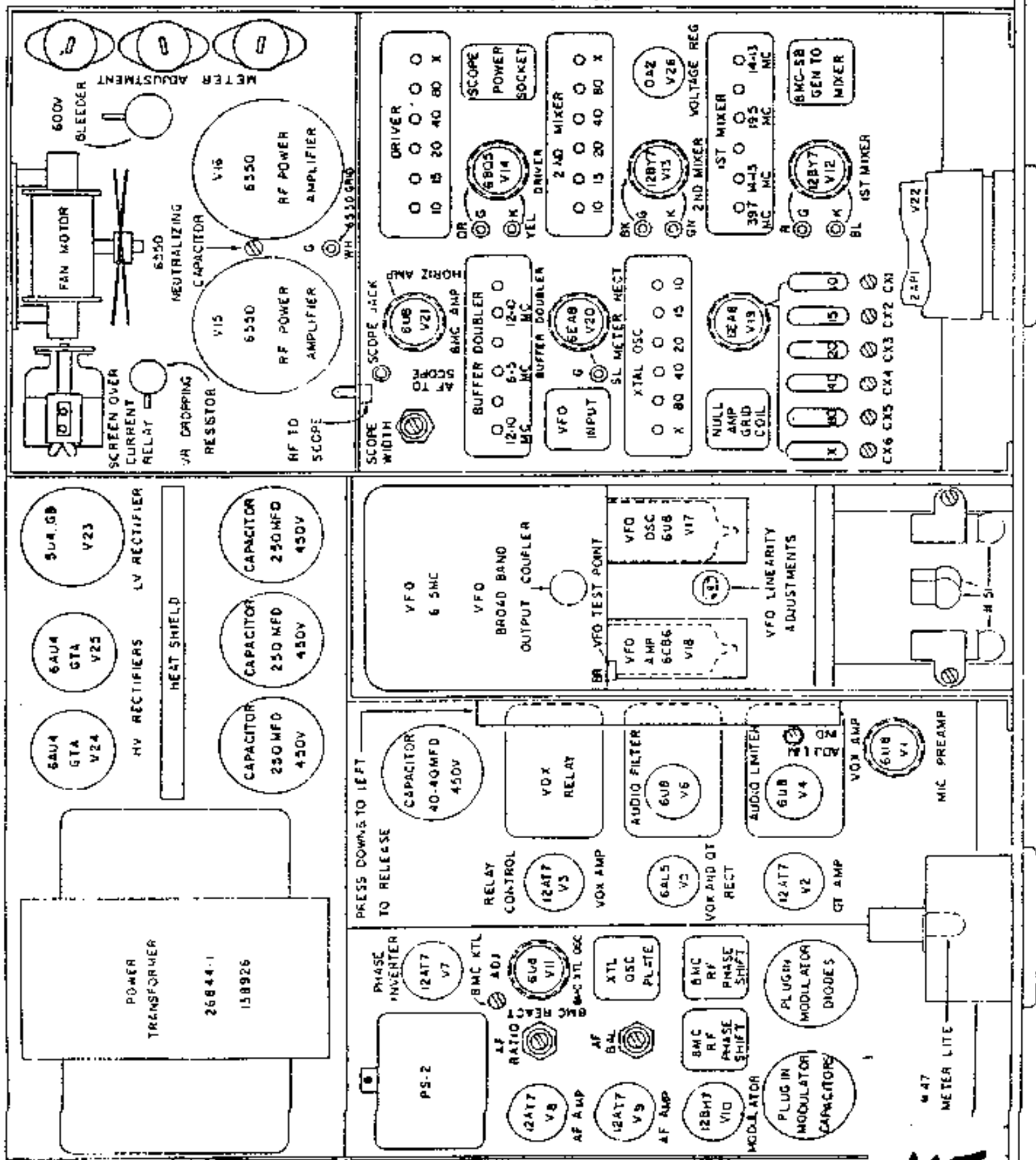

AMPS OUT

AC LINE

WATTS IN

○ TEST POINT JACK

TO REMOVE 2AFC CRT REFER TO CHAPTER ON MAINTENANCE & REPAIR

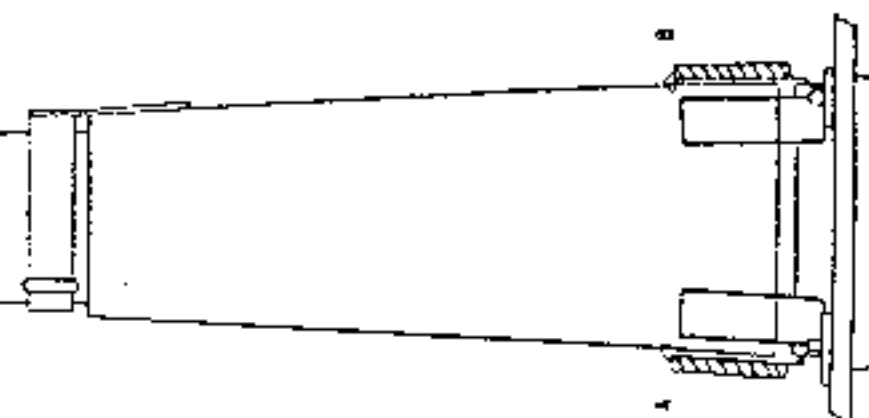
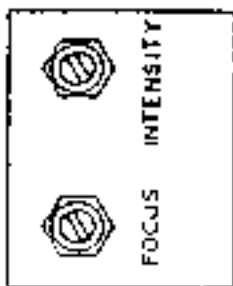

45

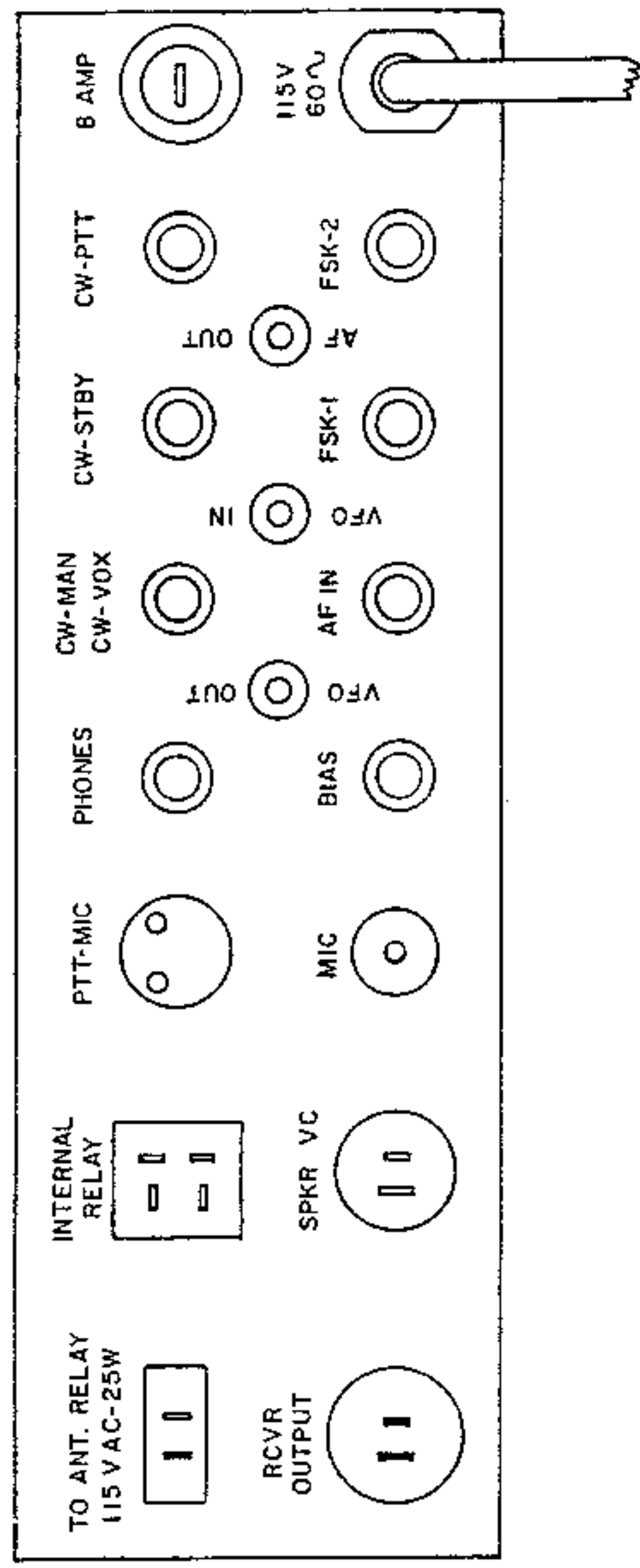
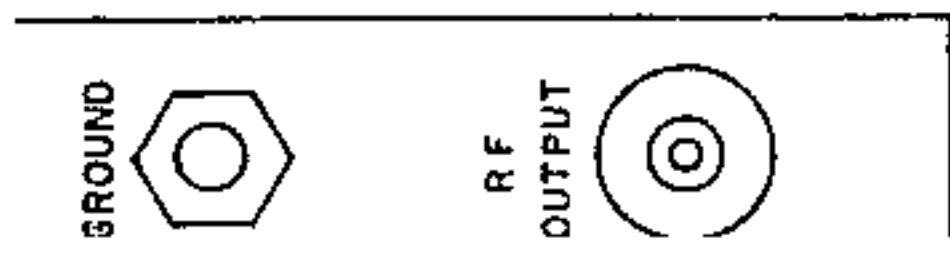

100V REAR CHASSIS CONNECTIONS

RELAY SHOWN ENERGIZED  
(TRANSMIT)

CONTACTS

- 2 and 3 In series with speaker voice coil. Closed in receive.
- 4 and 5 Grounds -100V DC blocking bias in transmit.
- 6 and 7 In receive, removes speech in CW CALIBRATE position.
- 7 and 8 In transmit, removes CW CALIBRATE carrier.
- 10,11,12 To 1, 4 and 3 respectively on INTERNAL RELAY socket on rear of chassis.

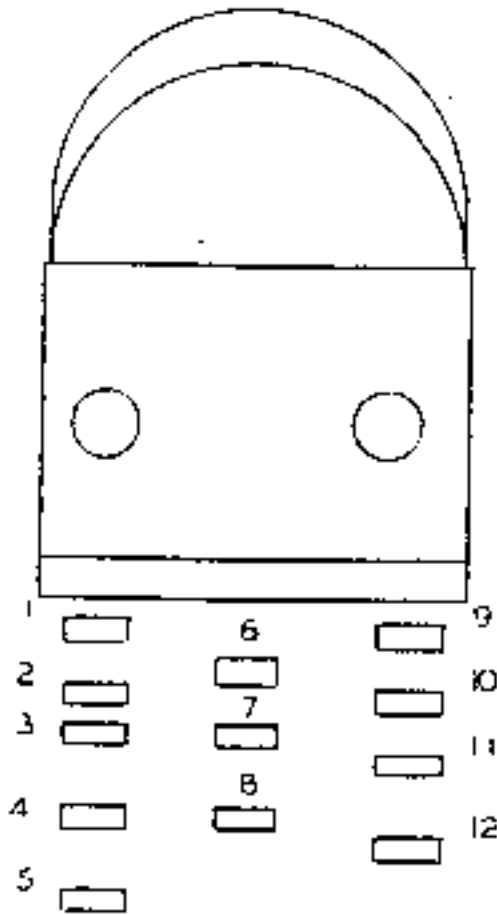

BOTTOM VIEW

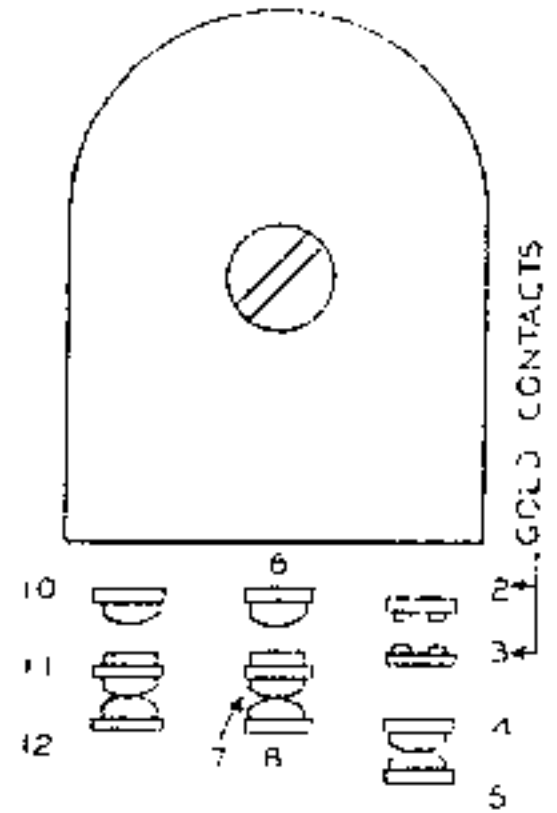

TOP VIEW

RELAY DIAGRAM

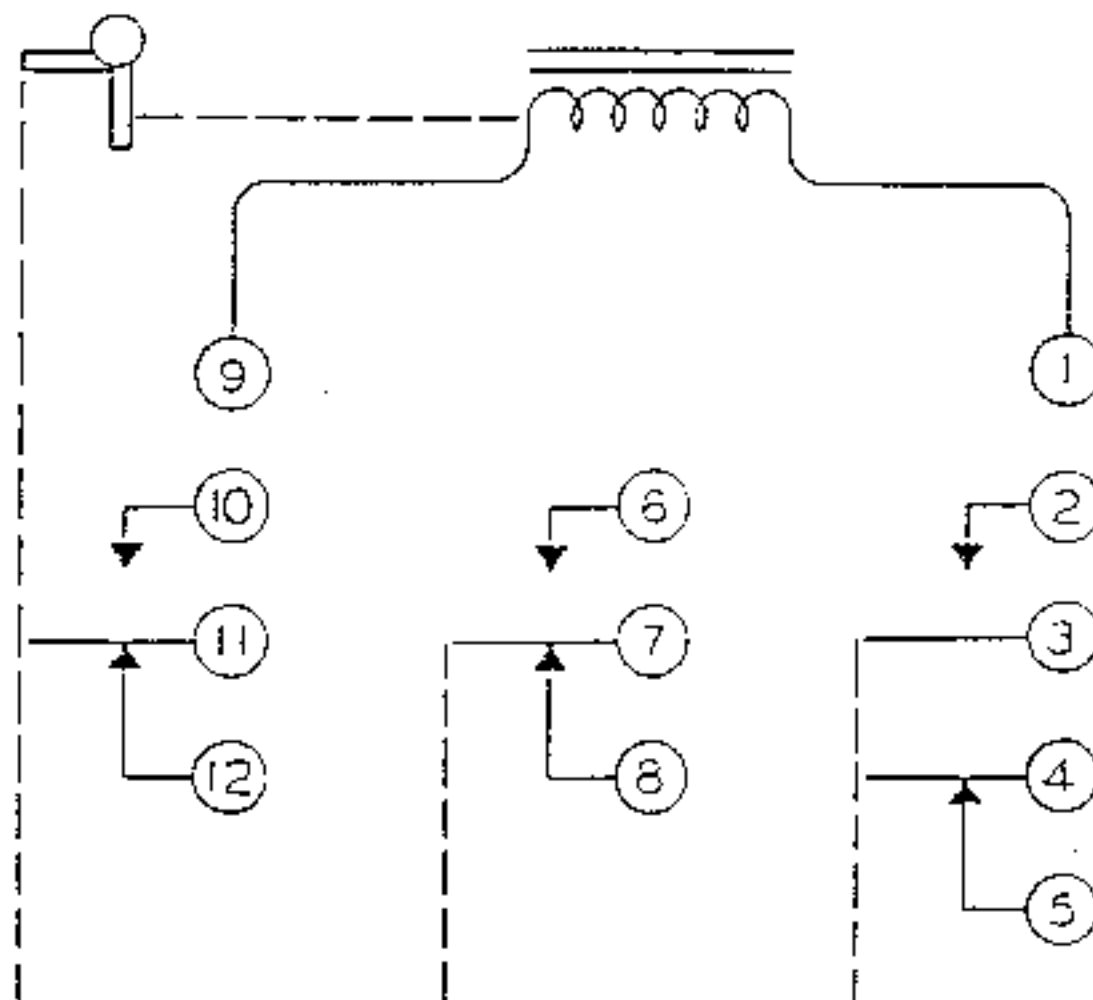



## 100V LIMITER BATTERY MAINTENANCE

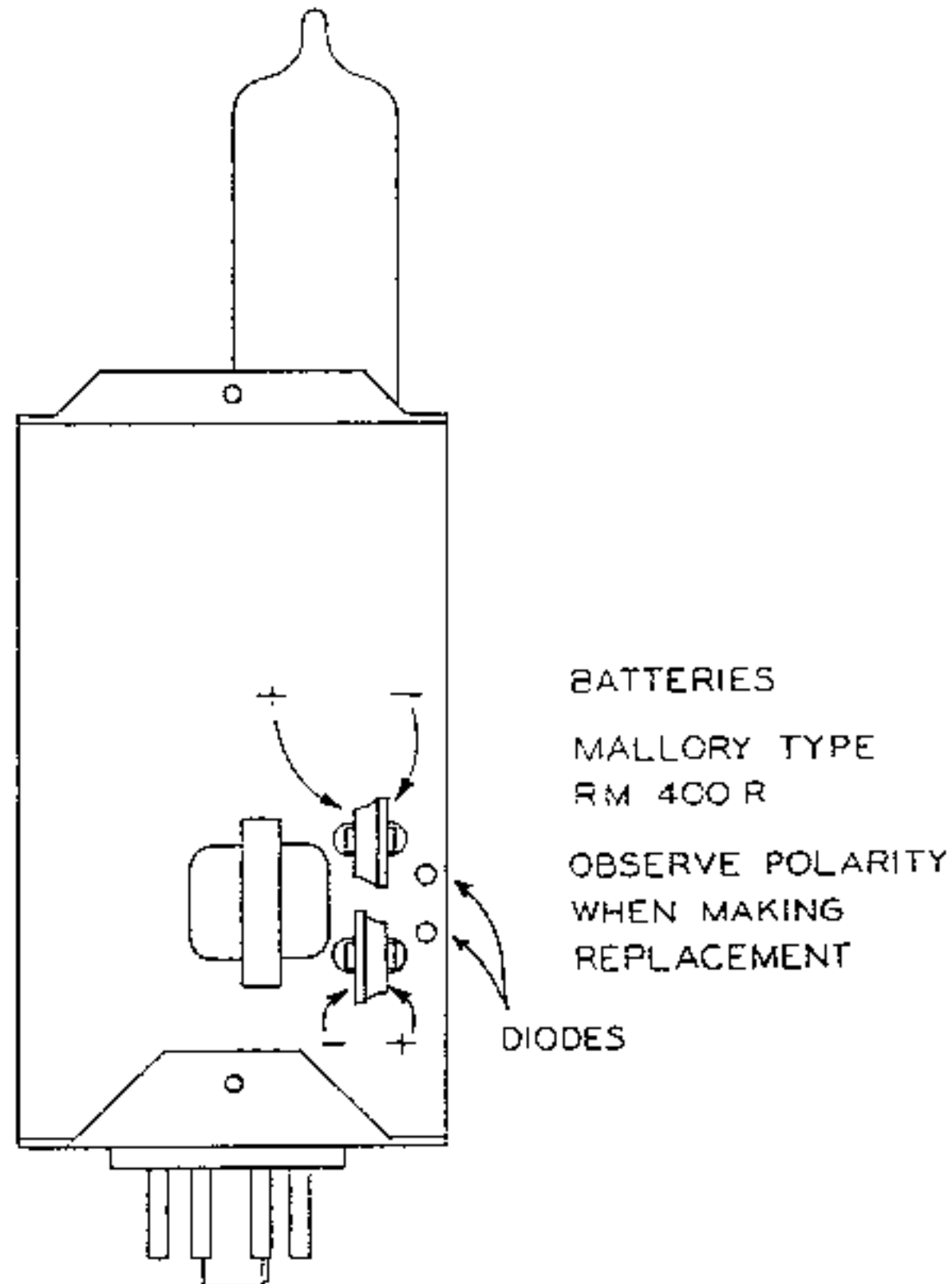

The normal life expectancy of the mercury batteries is several years, and will be equal to their "shelf life". Due to the circuit arrangement, the batteries will charge when the limiter operates. When their internal resistance becomes too high, the output of the limiter will rise appreciably and the RF stages may "flat top" with speech.

If a germanium diode develops leakage, the audio gain will be reduced considerably, since this will cause the inverse feedback to be applied at all speech levels instead of the higher levels only.

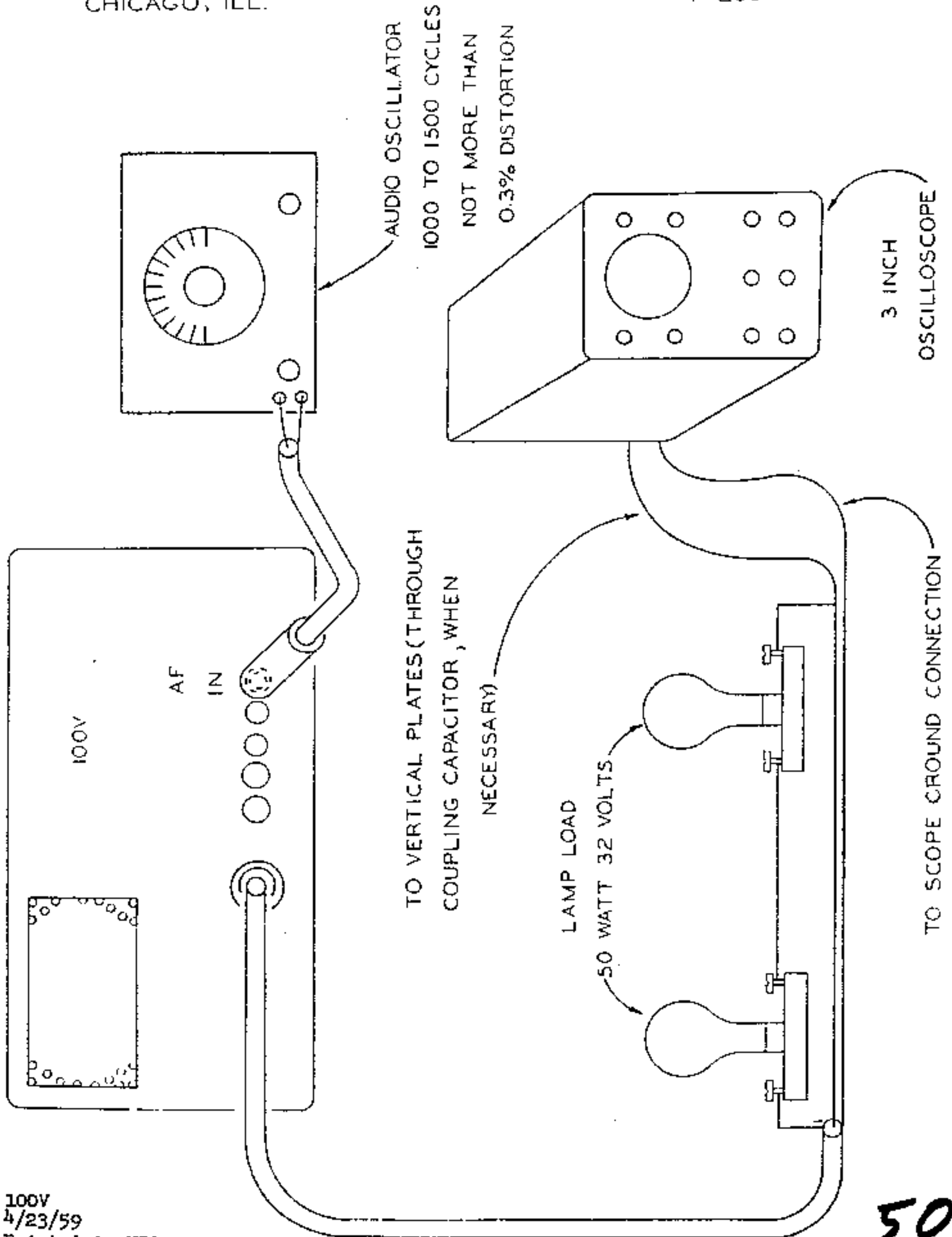

A low distortion audio oscillator and an external oscilloscope are required to obtain these patterns.  
CAUTION: When making these sideband suppression tests, be sure to remove the plugin Audio Limiter module and replace it with a jumper from terminal 2 to terminal 6 of the socket instead. Audio harmonics generated by the limiter will appear as ripple on the pattern, and furnish an invalid display of the true sideband suppression.

SSB signal, tone input, sideband suppression approximately 50 db., or audio test oscillator distortion 0.3%

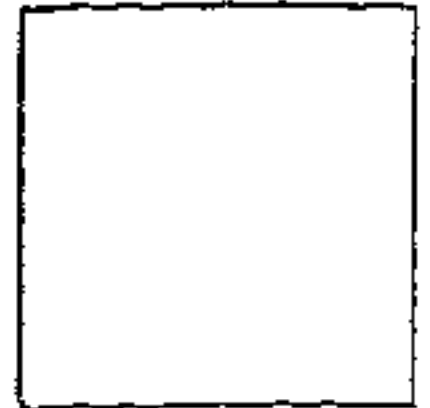

Same as above. Sideband suppression 40 db., or audio test oscillator distortion 1%

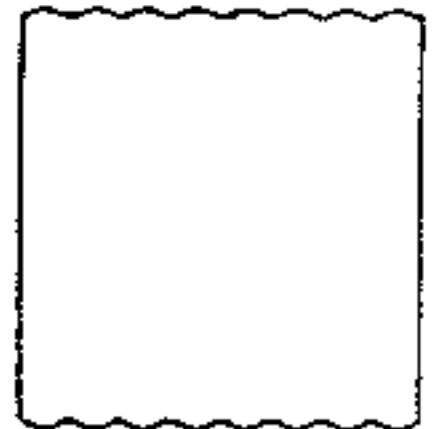

Same as above. Sideband suppression 30 db., or audio test oscillator distortion 3%

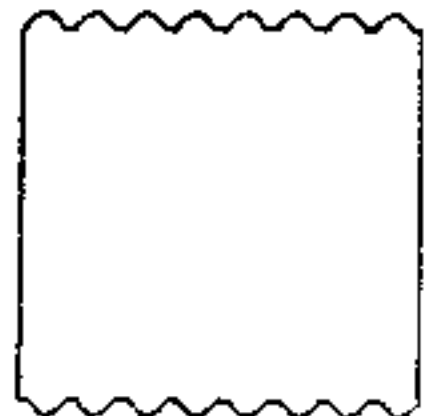

Same as above. Sideband suppression 20 db., or audio test oscillator distortion 10%

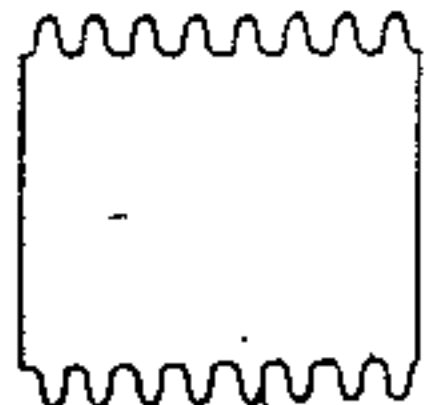



XT-10-15-20-40-80

XTAL OSCILLATOR PLATE COIL CHART

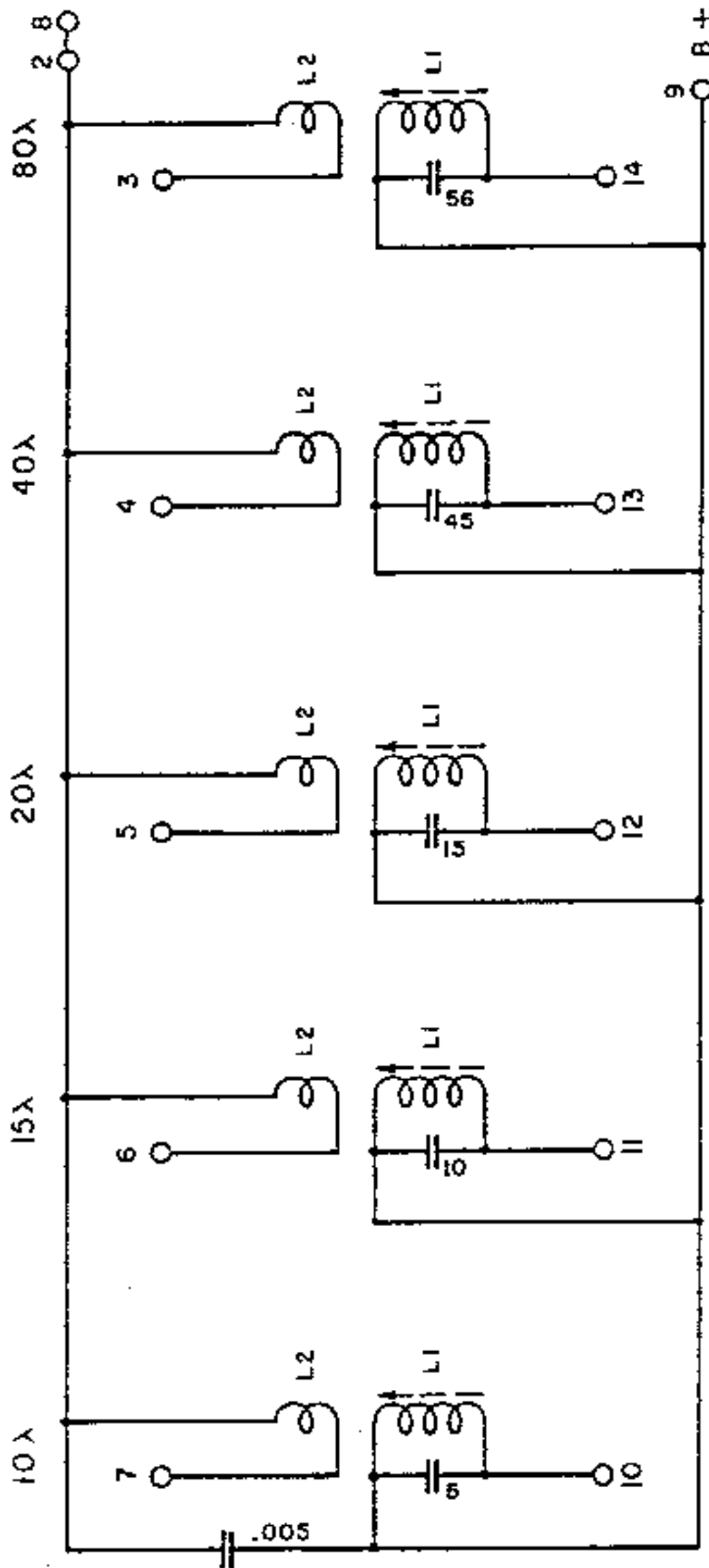

SHIELD CAN BRACKET IS  
CONNECTED TO TERMINAL  
# 2 (GROUND)  
LINK END OF L1 GOES TO  
B + BUSS BAR

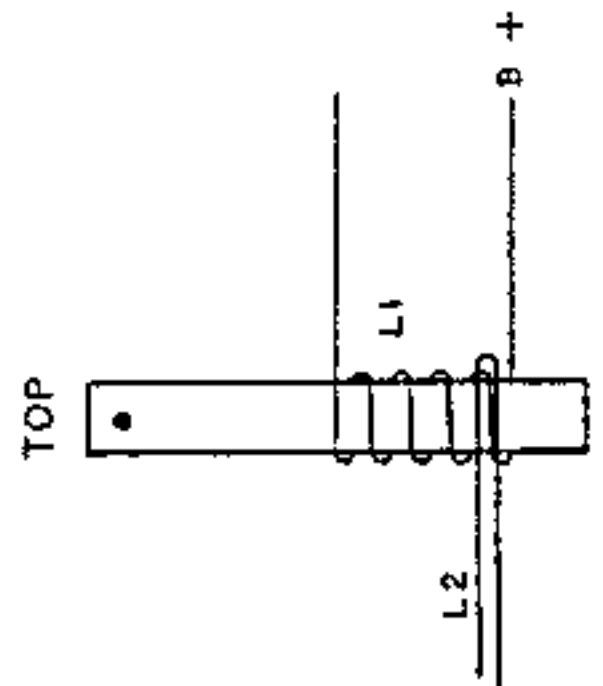

52

2M-10-15-20-40-80

2ND MIXER COIL CHART

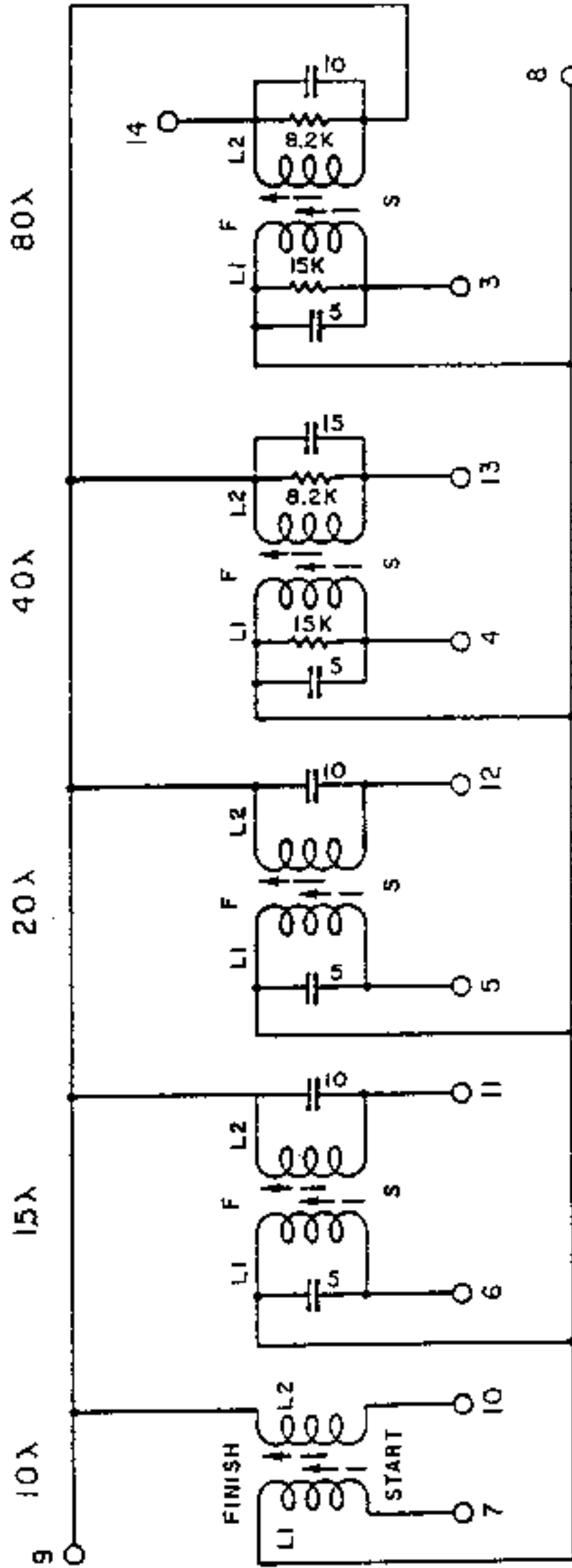

SHIELD CAN BRACKET IS  
CONNECTED TO TERMINAL  
# 2 (GROUND)

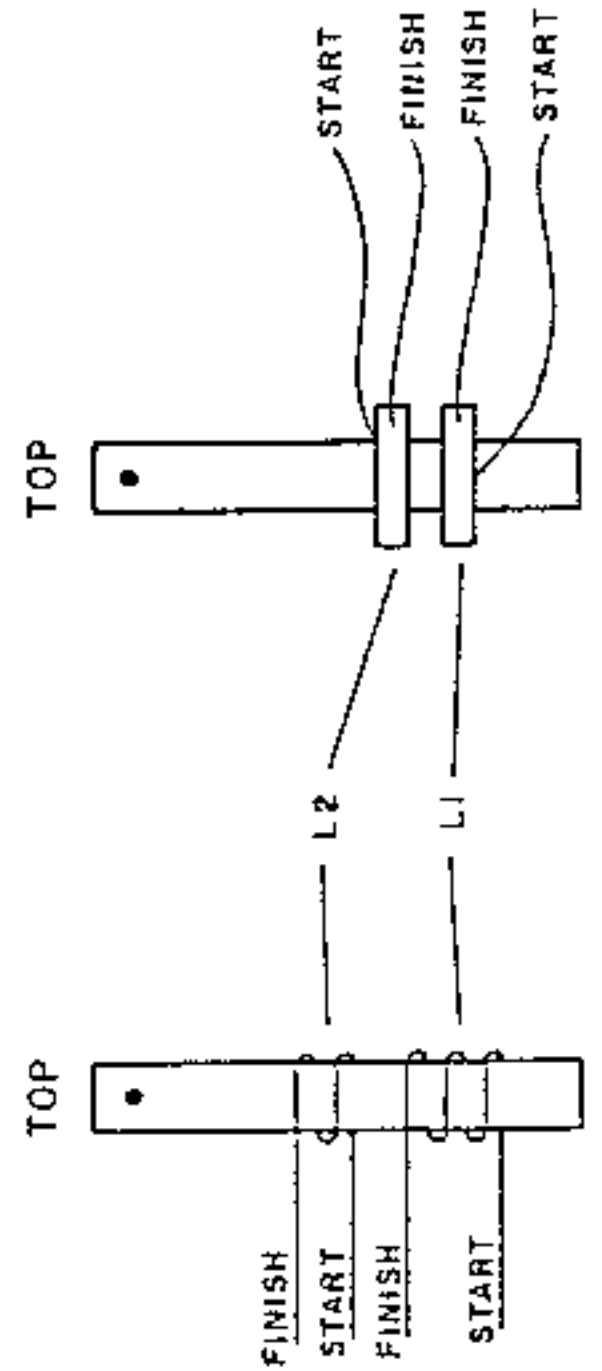

53

D-10-15-20-40-80

DRIVER COIL CHART

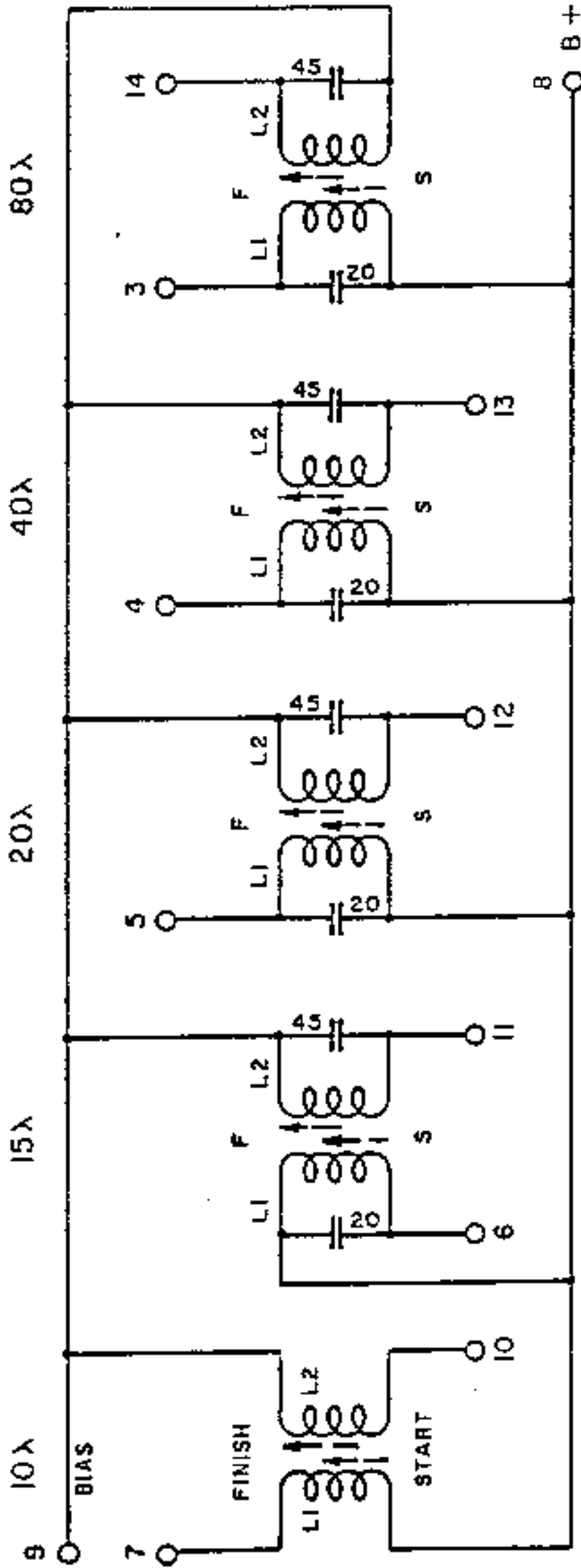

SHIELD CAN BRACKET IS  
CONNECTED TO TERMINAL  
# 2 (GROUND)

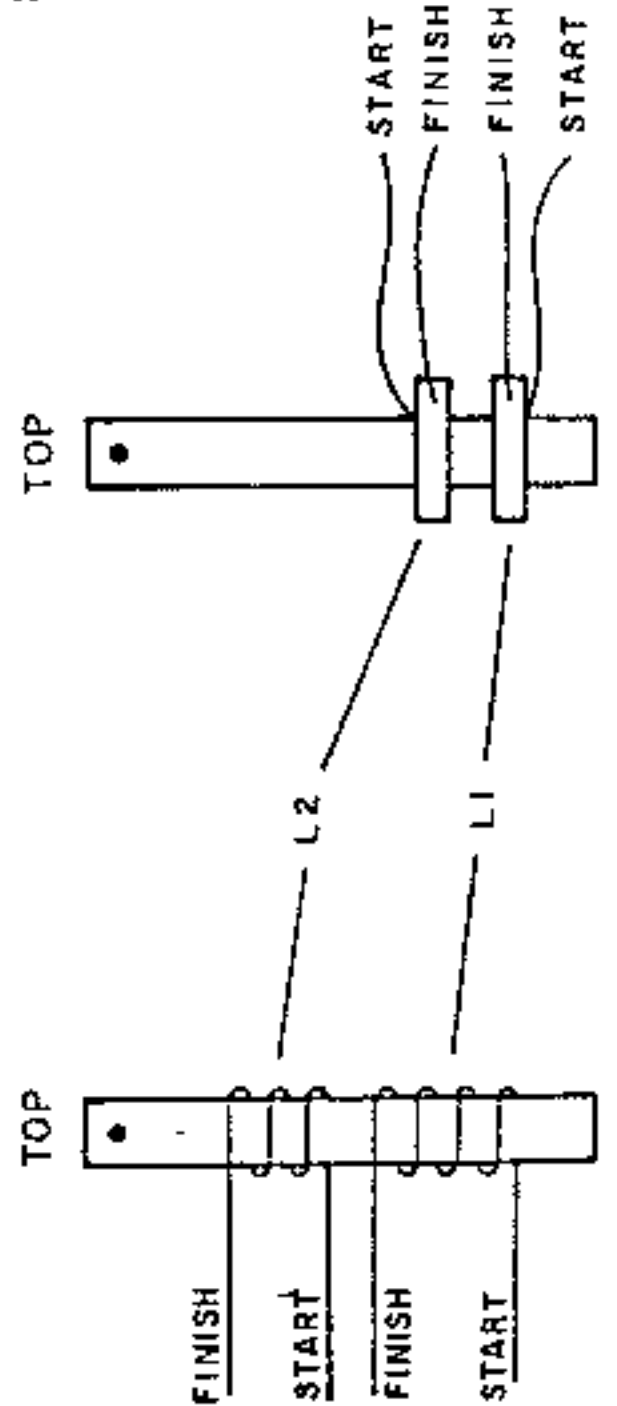

PROCEDURE TO MODIFY MODEL 100V  
FOR IMPROVED SUPPRESSION OF UNWANTED MIXER PRODUCTS

There are basically three categories of 100V's--those without rheostats in the mixer circuits from serial 1 through 448; those with mixer rheostats from serial 449 through 862; and all units from serial 863 and up that have mixer rheostats and improved mixer circuits.

Some units below 448 have had mixer rheostats installed at the factory; however, they may still require mixer circuit revision. These can be identified by the shaft of a rheostat protruding from the right side of the chassis below the first mixer plug-in coil unit. Units below serial 863, stamped with the letter "V" following the serial number, have all the mixer changes.

Detailed Procedure for Units with Serial Numbers between 1 and 448 (without rheostats)

- A1. Remove chassis from cabinet.
- A2. Remove bottom plate. At the socket of the 12BY7 first mixer V12, remove 47K 1/2 watt resistor R445B from pin #8 to ground (not in some early models).
- A3. Change R445 from 47K to 10K between pin #8 of V12 and pin #8 of 15 pin plug-in first mixer coil socket.
- A4. Remove R447, a 330 ohm 1/2 watt resistor and install a 100 ohm, a .005 capacitor, and the miniature 3000 ohm rheostat in place of it. (See circuit sketch). The rheostat should be mounted with heavy wire leads and positioned so that it may be adjusted from the bottom. If desired, holes may be drilled in the bottom plate to facilitate adjustment.
- A5. At the socket of the 12BY7 second mixer V13, drill 3/8" hole in side of chassis (5" back from the front panel and 1/2" from the bottom of the chassis), and mount a 100K potentiometer.
- A6. Install a 27K 1/2 watt resistor (R435A) from screen (pin #8) to one end of the 100K potentiometer.
- A7. Ground the center arm of the 100K potentiometer.
- A8. Remove 330 ohm at junction of 100 ohm and .005 capacitor and install a 250 ohm rheostat. Connect the rheostat between junction of 100 ohm and .005 to ground. Note! Case is one side of rheostat.

Changes Required for 100V's from Serial 449 through 862 that do not have the Letter "V" Stamped after the Number.

At R447B, the 250 ohm rheostat (with 330 ohm in series) located directly underneath the 2AF1 tube, next to the crystals:

- B1. Cut the 330 ohm resistor at the junction of the 100 ohm resistor and .005 capacitor.

- B2. With a heavy cutting pliers, cut or break off the old 250 ohm rheostat. Drilling out the rivets is not recommended, since the bandswitch is directly beneath and could easily become damaged.
- B3. Remove the old 1/4" length of insulated sleeving from the old rheostat and slide it on the terminal of the 3000 ohm unit.
- B4. Solder a 2" insulated lead to the lug on the new 3000 ohm rheostat.
- B5. Insert the 2" piece of wire through the top of the chassis, and solder the rheostat flanges to the chassis.
- B6. Solder the end of the 2" wire to the junction of the 100 ohm resistor and .005 capacitor.
- B7. Remove R445 and R445B (both 47K 1/2 watt) on pin #8 of V12, first mixer.
- B8. Replace R445 with 10K 1/2 watt from pin #8 of V12 first mixer tube to pin #3 of first mixer plug-in coil socket.

\*\*\*\*\*

#### Adjusting the Mixer Rheostats (R436, R440A and R447B)

In order to reduce the extra beat products in the 100V output to an absolute minimum, a rheostat (R447B) is used in the cathode circuit of the first mixer tube. A screen rheostat (R440A) and cathode rheostat (R436) are used in the second mixer tube. These rheostats are adjusted to minimize unwanted frequencies.

Physical location of rheostats on units serial #448 and below:

- First mixer cathode (R447B) - Underneath the first mixer tube, V12.
- Second mixer cathode (R436) - Underneath the second mixer tube, V13.
- Second mixer screen (R440A) - On the right side of the chassis near the front panel, just above the mounting bracket for the rubber foot.

Physical location on units serial #449 and above:

M241

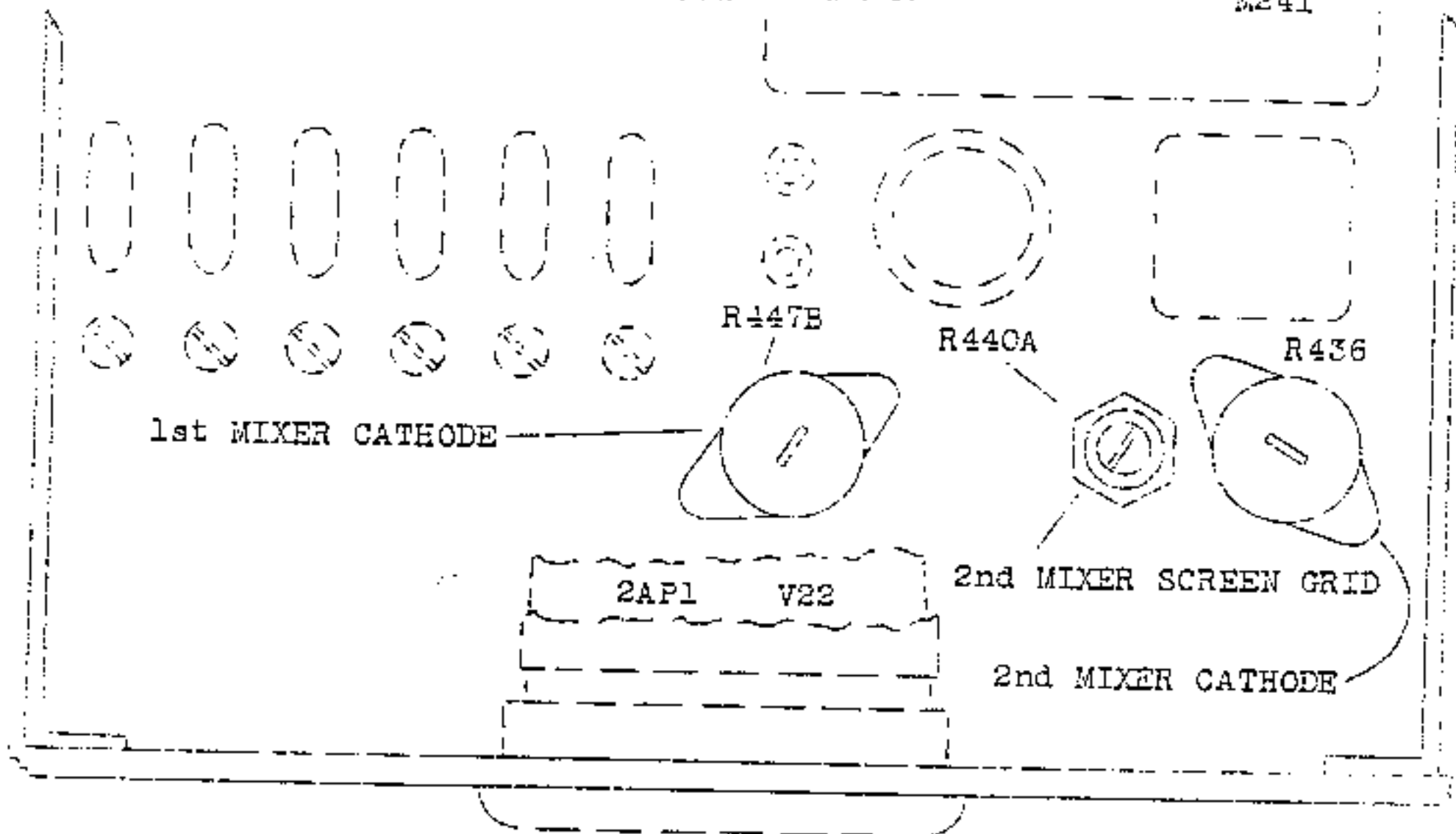

Use a 150 watt lamp load on the 100V, with about 150 to 175 watts CW input on the 40 meter band. Remove the antenna from the receiver. Well shielded receivers may require a short piece of wire, a few inches long, to obtain sufficient signal pickup from the 100V. Try to adjust the pickup so the signal reads near full scale on the "S" meter. Keep the BFO off, the AVC on, and the RF gain on full. Adjust audio to comfortable listening level.

Tune the 100V VFO to 7200 KC. Tune the receiver to 7300 KC, to coincide with the spurious signal. Adjust the first mixer (R447B) cathode rheostat for minimum "S" meter reading. Make sure control goes through a null. Now tune the 100V VFO to 6675 KC and the receiver to 7000 KC to coincide with the spurious signal. Adjust R436 and R44CA for minimum "S" meter reading. Varying either of these controls will usually affect the other; so it will be necessary to keep adjusting them alternately until a minimum is obtained. Be sure that these adjustments do not reduce the power input more than 20%.

Note: These null points on the "S" meter will not necessarily be zero, due to varying characteristics of each manufacturer's "S" meter circuit. If you check your "S" meter with a laboratory standard signal generator, the level of the spurious signal in question can be determined, provided the receiver is clear of its own spurious pickup response.

It is recommended that these adjustments be checked whenever a mixer tube is changed.

INSTALLING THE MIXER RHEOSTATS IN THE 100V

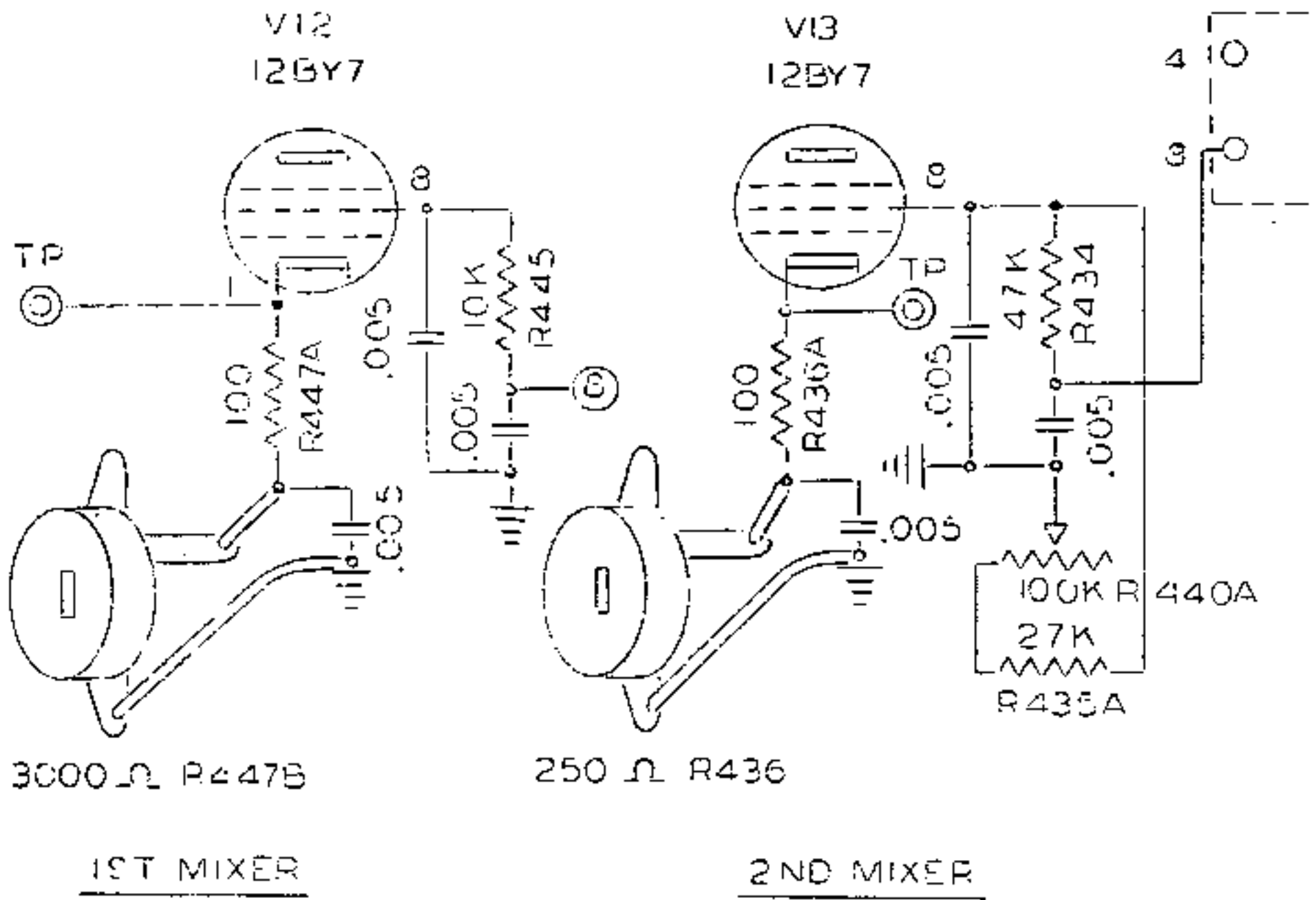

PARTIAL SCHEMATIC SHOWING DESIRED REVISED CIRCUIT.

JANUARY 1961

## 100V ALTERNATE H.F. CRYSTAL OSCILLATOR CIRCUIT

To convert the original H.F. crystal oscillator circuit to the new alternate circuit, the following parts are required:

- 3 Capacitor ceramic disc .005 RMC Sub. Min.
- 1 Capacitor ceramic disc 4 mmfd 5% NPO "C"
- 1 Choke RF .022 mh.
- 1 Resistor carbon 10K 1/2 w 10%
- 1 Resistor carbon 56 ohm 1/2 w 10%

Please return the five original crystals.

## PROCEDURE:

1. Remove three ground wires marked "X". See wiring diagram (V19A), and cut black lead "Z" as shown. Solder this black wire to the socket lug of T12.
2. Remove green wire on Pin #9; remove ground on Pin #8; also remove the IN95 diode. Cut this diode lead off next to the socket pin, so that the diode will not be overheated when soldering later.
3. Connect green wire and the choke (.022 mh) to Pin #8 and solder.
4. Add a .005 from Pin #9 to ground lug of socket.
5. Remove IN95 diode from Wafer #7 by cutting off next to tie point on the Wafer.
6. Remove 100K resistor end (that goes to Wafer #7) and reconnect to tie point, spare hole in Wafer #6. Add the 10K resistor in parallel with a .005 capacitor and then reconnect the diode to tie point of Wafer #6. Observe polarity as shown (it is reversed from original circuit).
7. Connect free end of 10K resistor and .005 capacitor combination to center pin of socket. Do not solder.
8. Add a .005 capacitor to center pin of socket. Solder.
9. Free end of .005 capacitor connects to Wafer #7 tie point (junction of diode and 2 - 68K resistors). Solder.
10. Add sleeving to a wire and connect from center pin of socket to ground lug of socket. Solder both ends.
11. Add the 56 ohm and 4 mmfd capacitor in series from the 20 meter crystal socket to Pin #1. Solder. Use sleeving, as shown, added to the 4 mmfd capacitor and solder to Pin #1 (with blue wire).
12. Remove all original crystals in this group of crystal sockets shown on diagram and install the five new crystals. Turn all crystal frequency trimmers to 1/2 inch out. Adjust crystal coil cores to frequency and maximum drive, as read by VFO-Receiver combination. Use trimmer if required to exact zero beat. Adjust crystal oscillator plate tuning cores for maximum input watts as well as frequency zero beat, at the same time, but do not have maximum power input as flat topping may occur, and peak resonance point would not be easily discernable. About 130 watts input will suffice.

2/29/60

59



# 100V ALTERNATE HF XTAL OSCILLATOR CIRCUIT

WAFERS COUNTED FROM FRONT PANEL  
 TP = TIE POINT = SPARE HOLE IN WAFER.  
 SOLID LINES = ALTERNATE XTAL CIRCUIT.  
 DASHED LINES = EXISTING CIRCUIT.

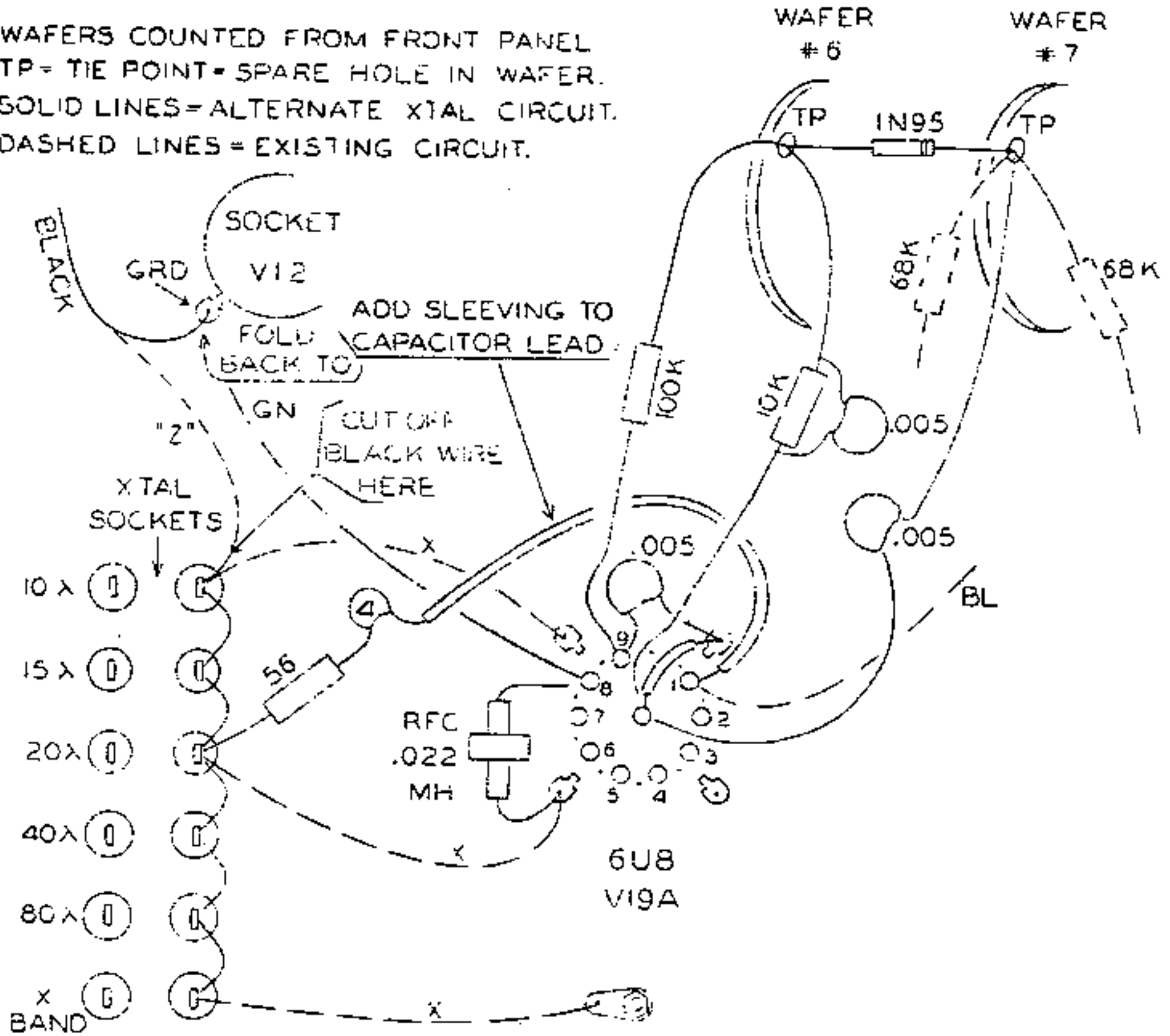

MODEL 100V  
 ALTERNATE HF CRYSTAL OSCILLATOR CIRCUIT  
 SERIAL No. 166 & UP

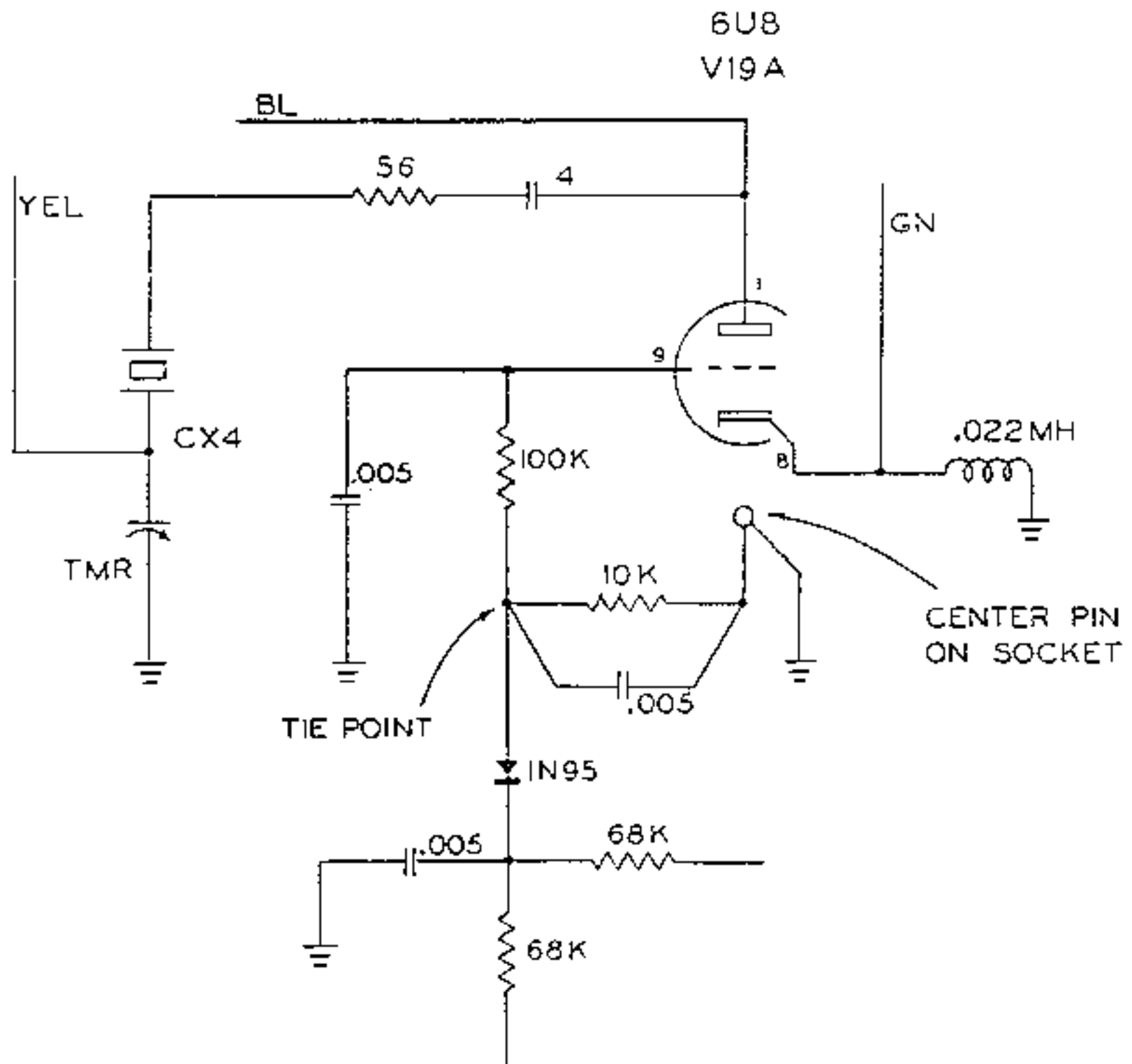

Instructions for Eliminating Hum in Speakers Connected to the 100V

On the diagram you will find six numbers with the following designations:

- (1) - terminal 15 of socket No. 1
- (2) - terminal 11 of socket No. 1
- (3) - terminal 2 of the RECEIVER OUTPUT chassis plug
- (4) - terminal 2 of the SPEAKER VOICE COIL chassis socket
- (5) - shunt terminal of the PHONE JACK
- (6) - tip terminal of the PHONE JACK

(wires to be cut out of circuit are shown by dashed lines and X's)

1) Disconnect the W-BK-Y wire connecting points (1) and (3) at these points and insulate the ends. CAUTION: Take care not to remove the W-BK-Y that goes to cable plug pin 8.

2) Disconnect the W-BK-Y wires at points (4) and (5) and insulate the ends.

3) Disconnect the W-BK-BR wire connecting points (2) and (6) at these points and insulate the ends.

4) Obtain a length of W-BK-Y wire and an identical length of W-BK-BR wire. Form these two wires into a tightly twisted pair.

5) Begin the substitute wiring at the phone jack by connecting the W-BK-Y wire to point (5) and the W-BK-BR wire to point (6) which are the shunt and tip terminals respectively.

6) Run the wire close to the chassis between the two microphone jacks and up to the speaker voice coil socket.

7) Cut the W-BK-Y wire ONLY at the speaker voice coil socket and unwind one turn from each cut end.

8) Connect the other end of the W-BK-Y wire which is attached to point (5) to point (4) which is terminal 2 of the SPEAKER VOICE COIL socket.

9) Connect the other cut end of the W-BK-Y wire to point (3) which is terminal 2 of the RECEIVER OUTPUT chassis plug.

10) Take up the slack in the W-BK-BR wire due to these operations by twisting in and running this twisted stub close to the chassis between the two 2-prong Jones plugs. Dress wires around choke to socket #1.

- 11) Dress wires between choke and chassis.
  - 12) Solder the remaining end of the W-EK-Y wire to point (1) which is terminal 15 of socket No. 1.
  - 13) Solder the remaining end of the W-EK-BR wire to point (2) which is terminal 11 of socket No. 1.
  - 14) Remove all slack from the wire crossing the compartment.
- This completes the modification.

# 100V SPEAKER CIRCUIT CHANGE

66

FOR UNITS SERIAL No 213 AND BELOW  
TO REDUCE HUM IN RECEIVER LOUD SPEAKER

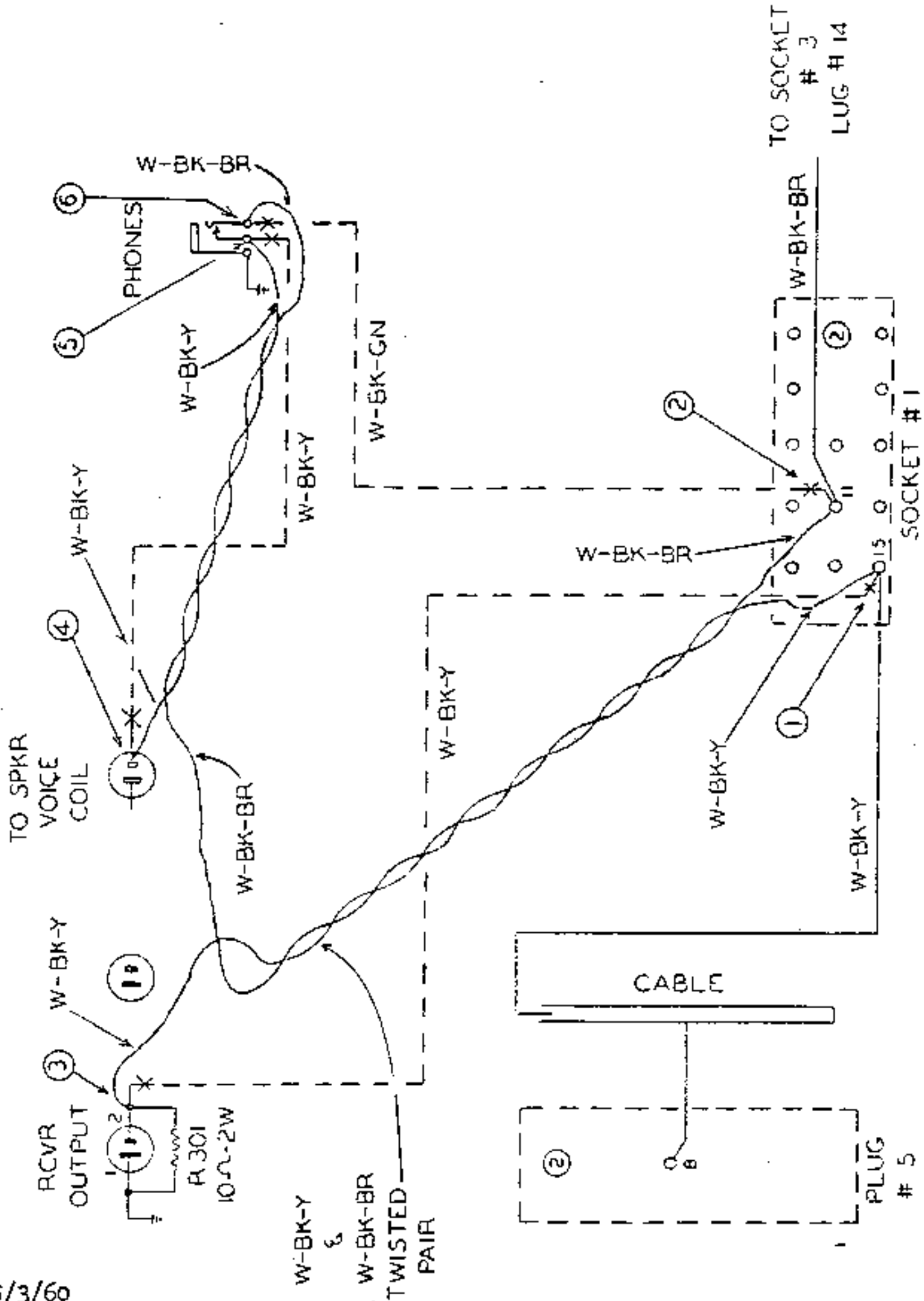

5/3/60

CENTRAL ELECTRONICS, INCORPORATED

M23:

64

RESISTOR CHANGE TO LOWER  
THE B SUPPLY VOLTAGE TO  
THE SSB GENERATOR.

TEN LUG TERMINAL STRIP ON BOTTOM  
OF POWER SUPPLY CHASSIS, BETWEEN  
FILTER CHOKE AND JACKS.

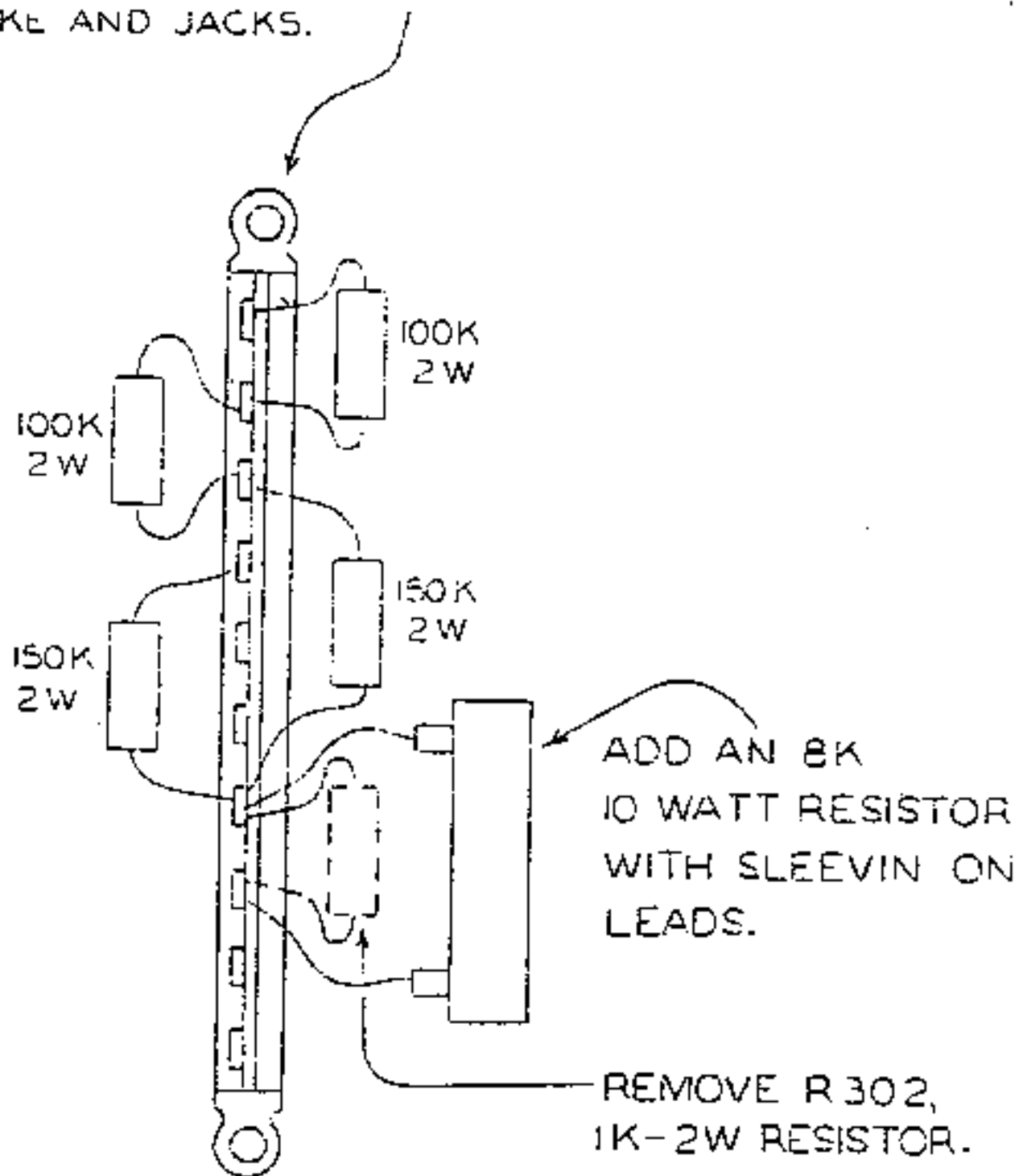

This change reduces carrier bounce (or flutter) when transmitter is first keyed "on", which may be noticed on some units. This applies to AM or SSB.

For units below serial No. 266.

3/18/60 Rev. 3/22/60  
Printed in USA

M232

CENTRAL ELECTRONICS, INCORPORATED.

65

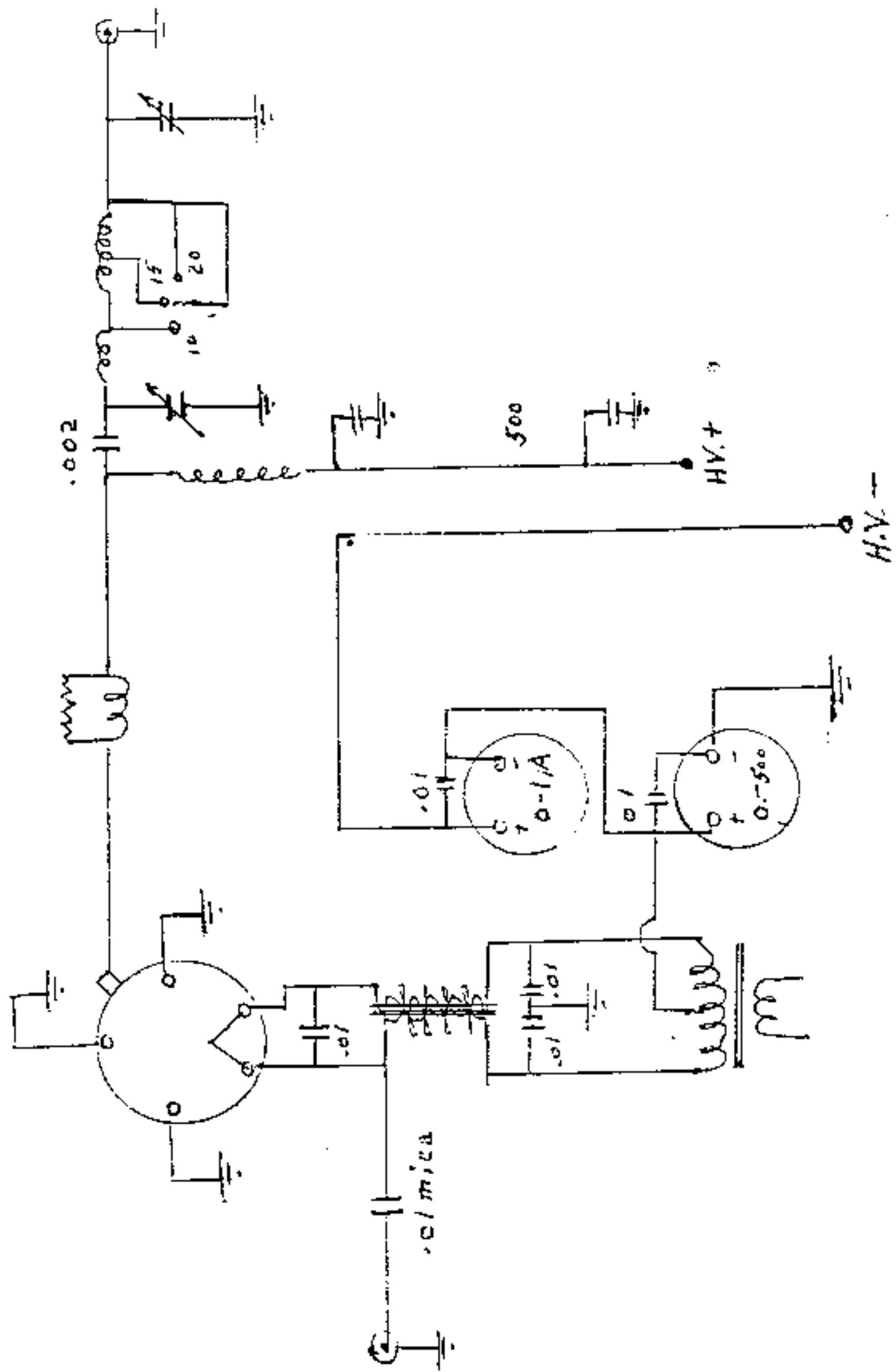

MODEL 100V

ALTERNATE HF CRYSTAL OSCILLATOR CIRCUIT

SERIAL No. 166 & UP

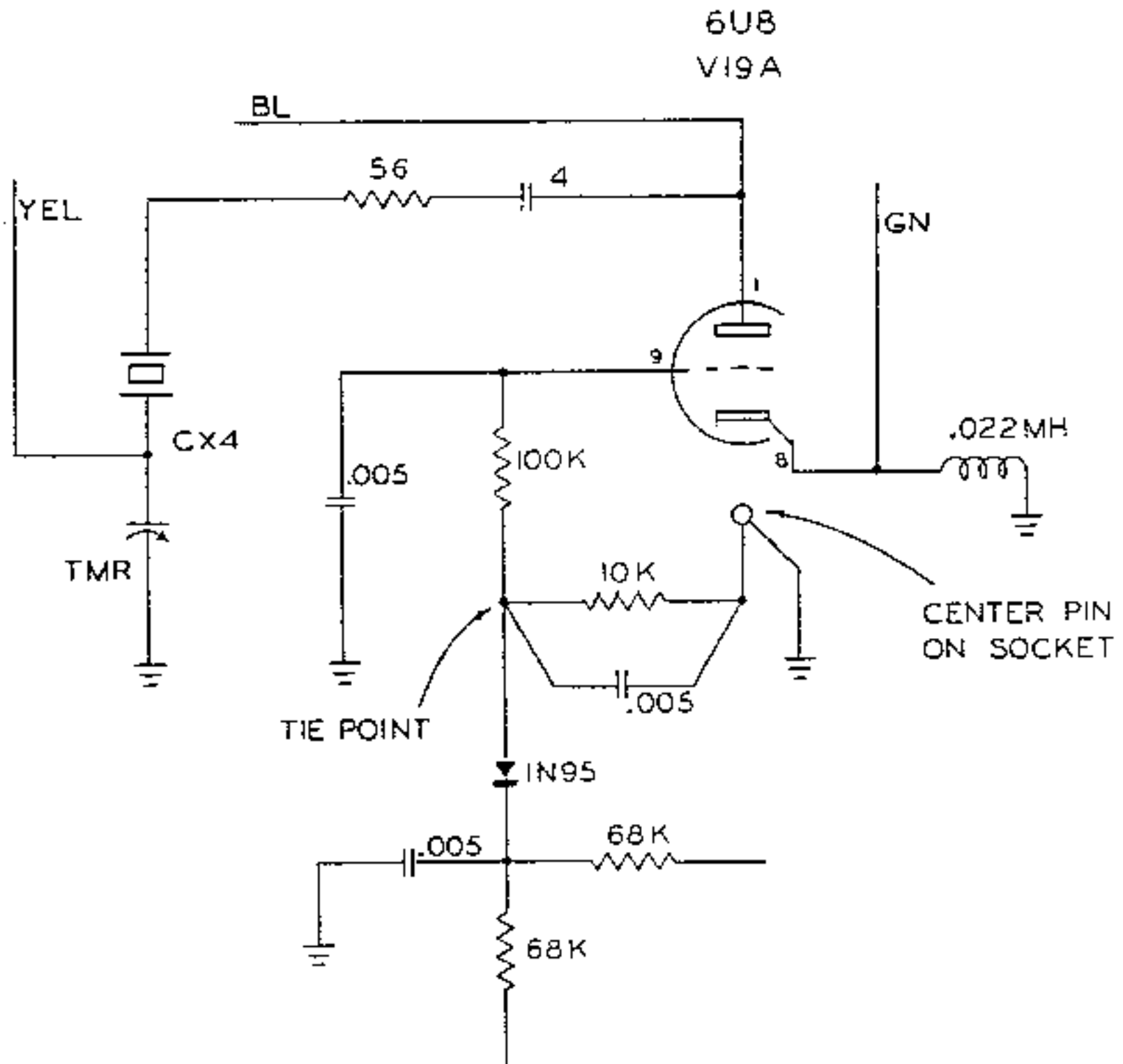



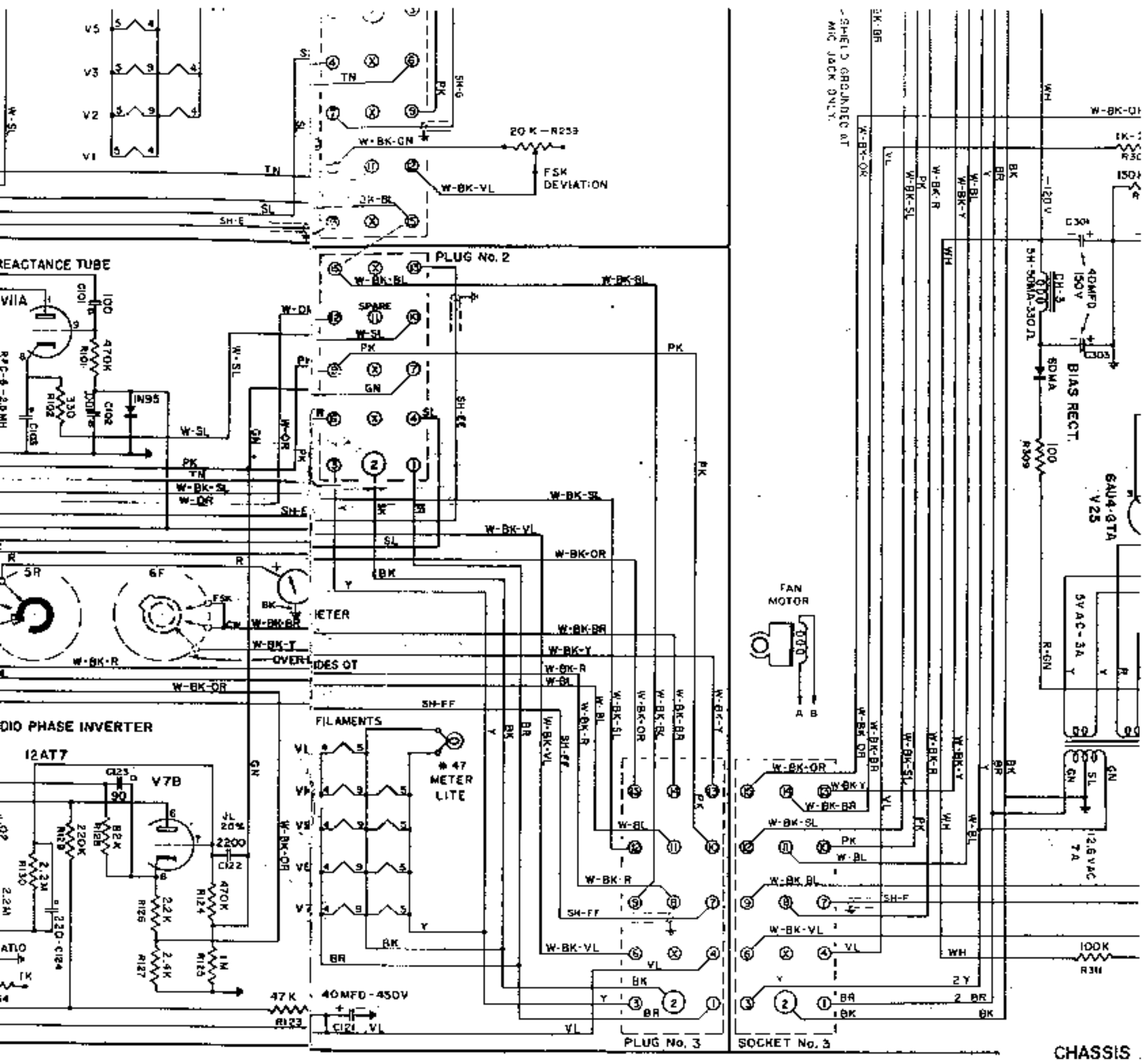

**CHASSIS**

RF DRIVER & XTAL OSC PLATE SHOW THE CIRCUIT USED ON THE 40 METER BAND. REFER TO CHART (IN INSTRUCTION MANUAL) FOR OTHER BANDS. EACH OF THE ABOVE PLUG-IN COIL UNITS CONTAINS SIX COILS. WHEN AN "X" BAND COIL IS INCLUDED.

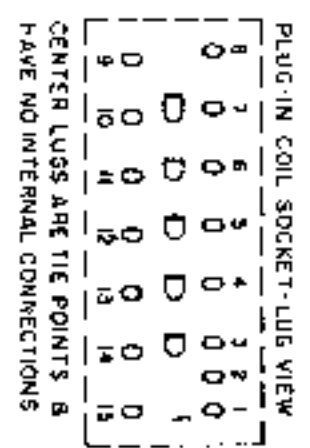

NUMBERED ARROWS AROUND THE GANGED BAND-SWITCH DESIGNATE WHERE WIRE CONNECTIONS GO TO A PLUG-IN-COIL GROUP ASSOCIATED WITH THE PARTICULAR SWITCH FUNCTION

LAST R AND C NUMBERS

- R:66 R287 R351 R490 R5:5
- C:45 C249 C307 C499 C5:4

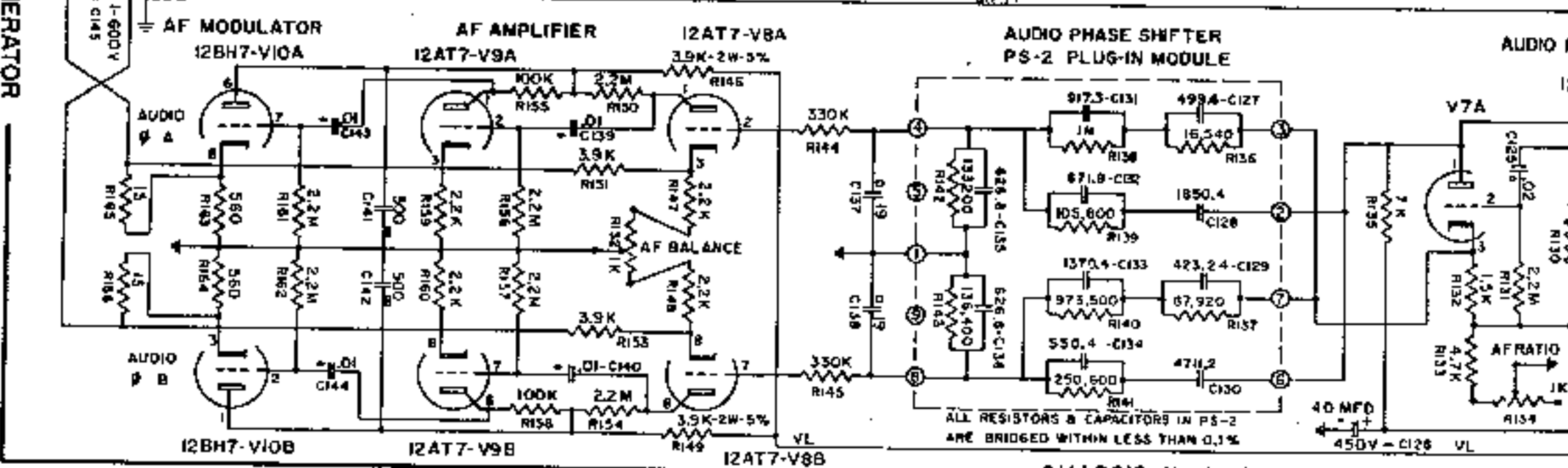
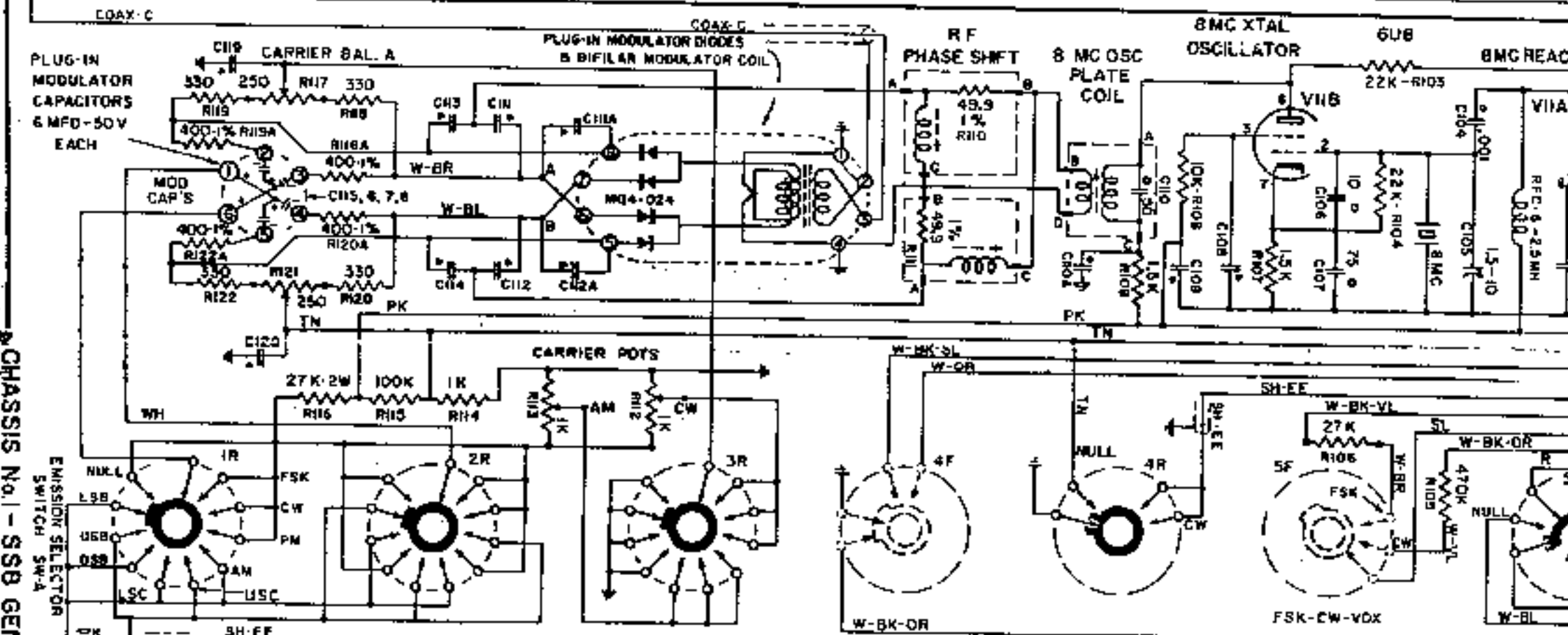
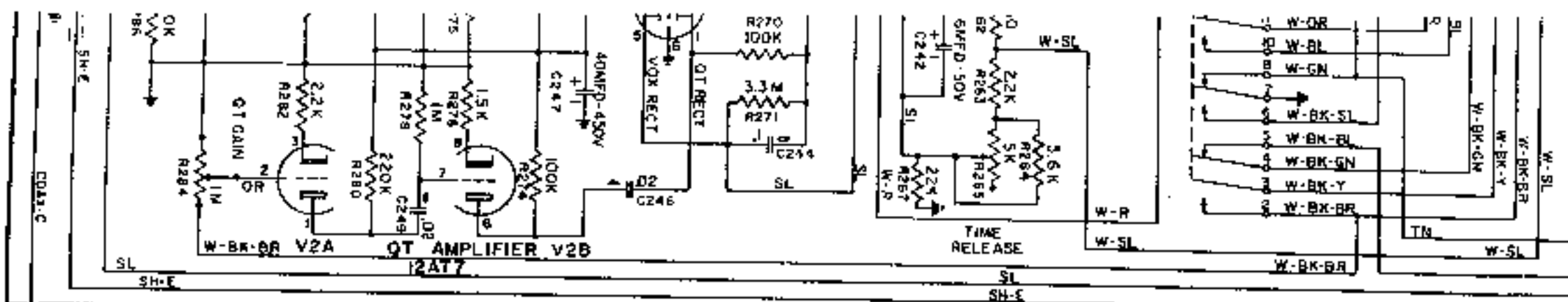

CHASSIS No. 1- SSB GENERATOR

CHASSIS No. 1 - SSB GENERATOR

SCHEMATIC & WIRING DIAGRAM  
RADIO TRANSMITTER  
MODEL 100V

CENTRAL ELECTRONICS  
CHICAGO

REV. 12-7-59 CHND GEM APPROV GEM  
REV. 11-6-59 CHND GEM APPROV GEM

ORGN. W2201 7-17-59

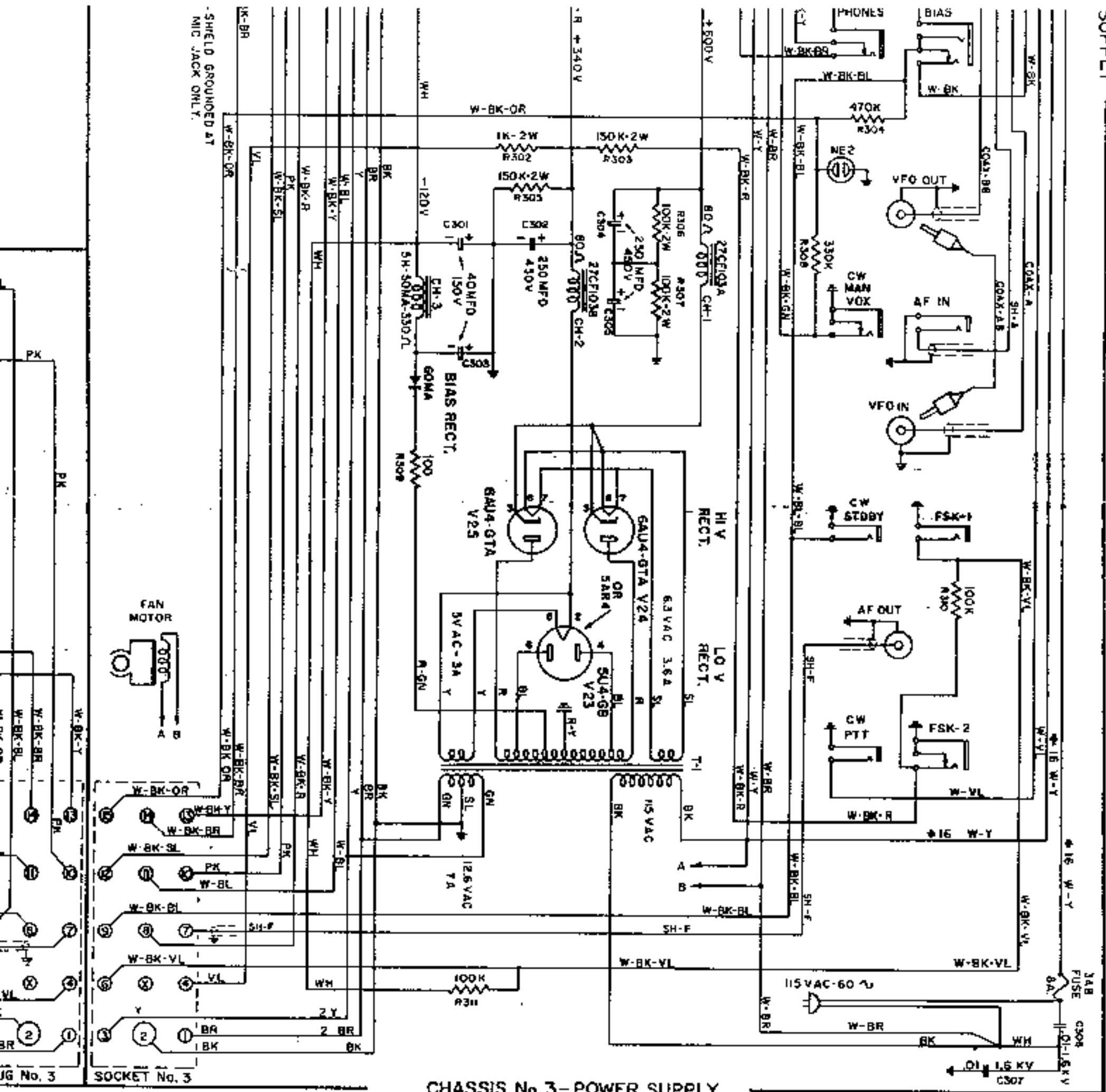

CHASSIS No. 3 - POWER SUPPLY

RESISTORS ARE 1/2 WATT 10% EXCEPT AS OTHERWISE SPECIFIED  
 R = x 1,000 M = x 1,000,000

CAPACITOR VALUES SHOWN DECIMALLY ARE MICROFARADS, OTHERS ARE MICROMICRO-FARADS EXCEPT AS OTHERWISE SPECIFIED

• .005 ± 20% CERAMIC CAPACITOR  
 • 10% JF OR JL  
 • 20% SM  
 • NPO  
 • +80% -20% TA  
 • 20% 25U  
 • SILVER MICA  
 • MYLAR

• LETTERED LUG  
 • TEST POINT (COLOR CODED)  
 SH = SHIELDED AUDIO CABLE

ALL SWITCHES ARE SHOWN AS SEEN FROM REAR. THE NUMBERS DENOTE WAFER POSITION. N.1 IS NEXT TO PANEL. THE LETTERS RAF DENOTE REAR & FRONT SECTIONS OF WAFER, RESPECTIVELY. THE FRONT SECTION CONTACTS ARE SHOWN BY DASHED LINES & ARE AS VIEWED THRU THE WAFER FROM REAR. THE BLACKED ROTORS ARE ON REAR SECTION, SOME WAFERS HAVE LUGS (WITHOUT CONTACTS) WHICH ARE USED AS TIE POINTS.

THE THREE PLUG-IN COIL UNITS, 2ND MIXER, RF DRIVER & XTAL OSC PLATE SHOW THE CIRCUIT USED ON THE 40 METER BAND. REFER TO CHART I IN INSTRUCTION MANUAL FOR OTHER BANDS. EACH OF THE ABOVE PLUG-IN COIL UNITS CONTAINS SIX COILS, WHEN AN "X" BAND COIL IS INCLUDED.

PLUG-IN COIL SOCKET LUG VIEW

8	7	6	5	4	3	2	1
0	0	0	0	0	0	0	0
0	0	0	0	0	0	0	0
9	10	11	12	13	14	15	

CENTER LUGS ARE THE POINTS B HAVE NO INTERNAL CONNECTIONS.

NUMBERED ARROWS AROUND THE GANGED BAND-SWITCH DESIGNATE WHERE WIRE CONNECTIONS GO TO A PLUG-IN COIL GROUP ASSOCIATED WITH THE PARTICULAR SWITCH FUNCTION.

LAST R AND C NUMBERS

- R166 R287 R341 R490 R513
- C1A5 C249 C307 C499 C514

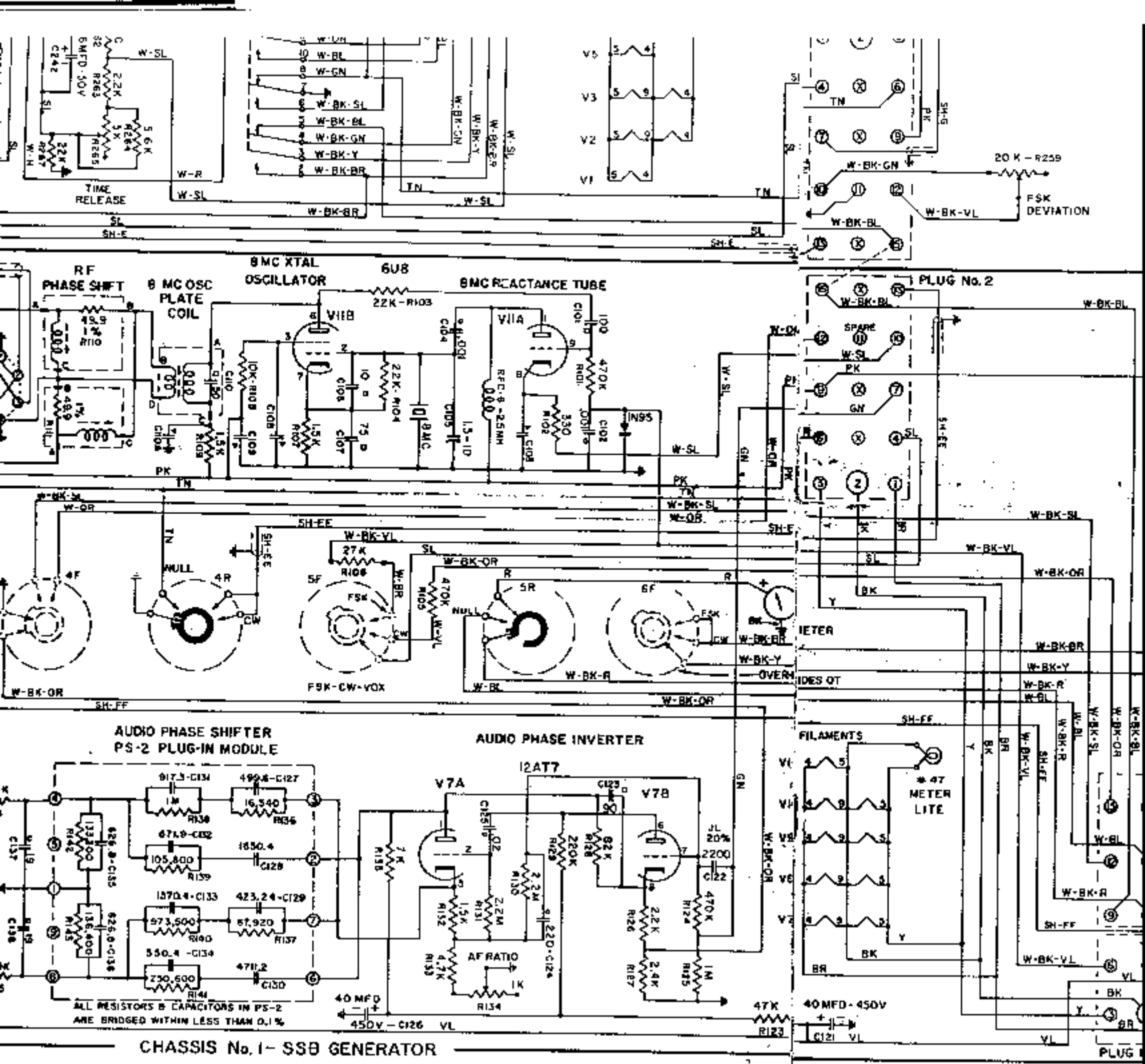

CHASSIS No. 3 - POWER SUPPLY

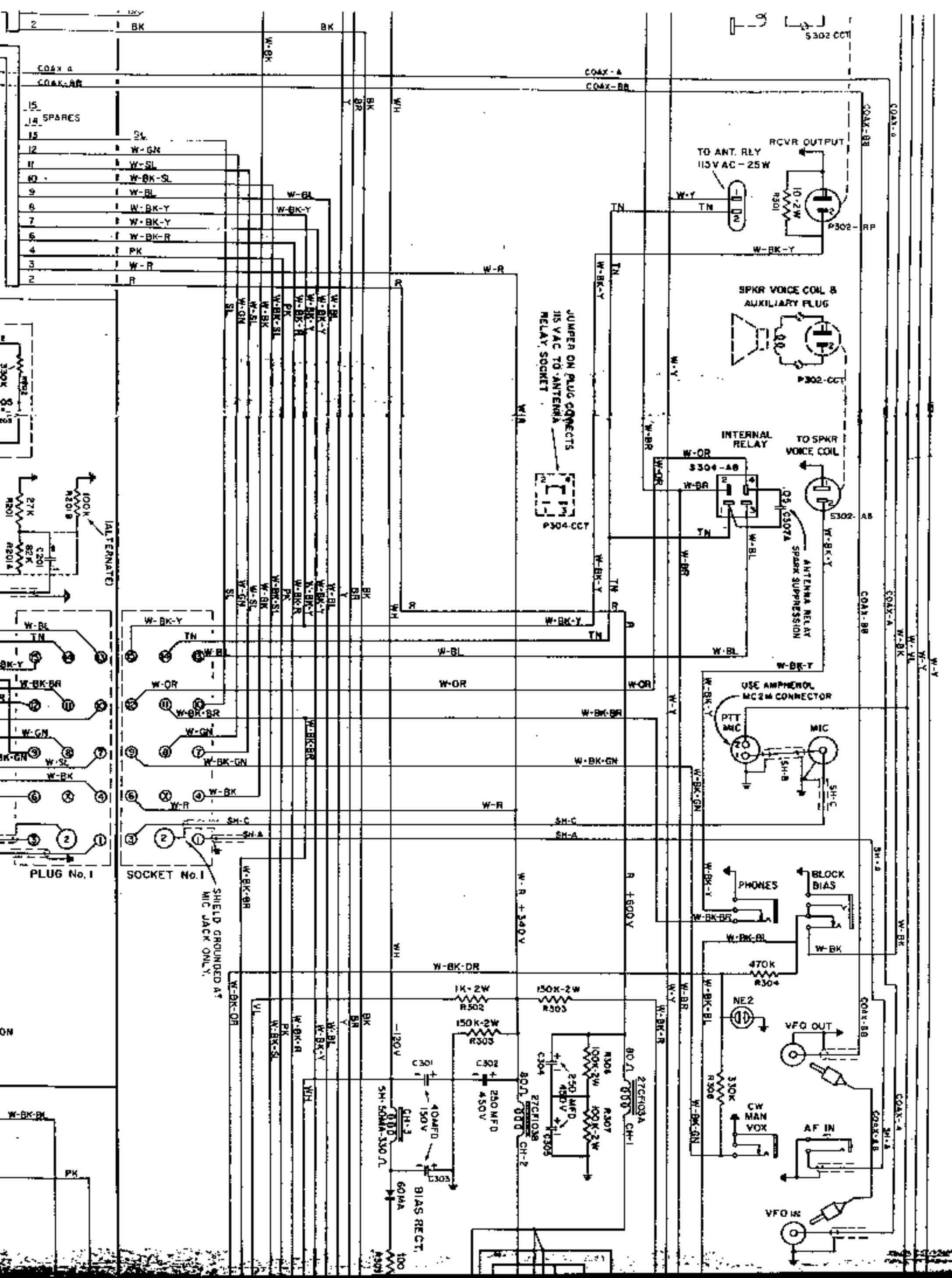

VFO

VFO AMPLIFIER

VFO OUTPUT 6.5 MC

COAX-A  
COAX-BB

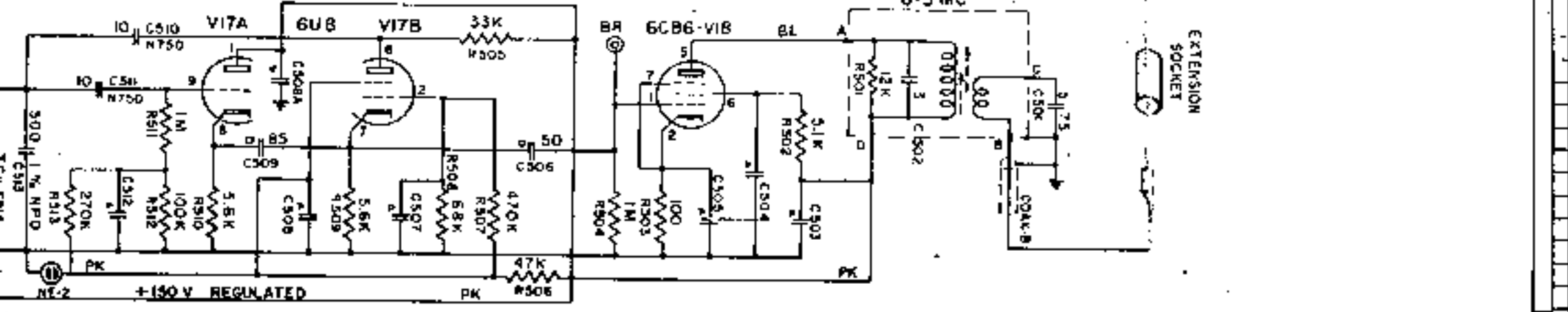

LIMITER PLUG-IN MODULE

AUDIO FILTER PLUG-IN MODULE

6U8-V4B

REFLEX AMPLIFIER FOR LIMITER INDICATOR

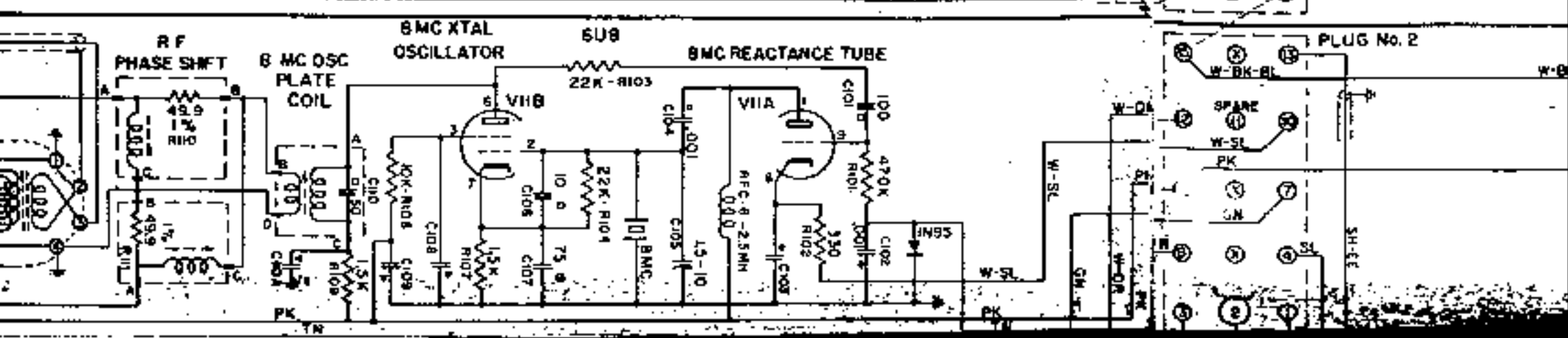
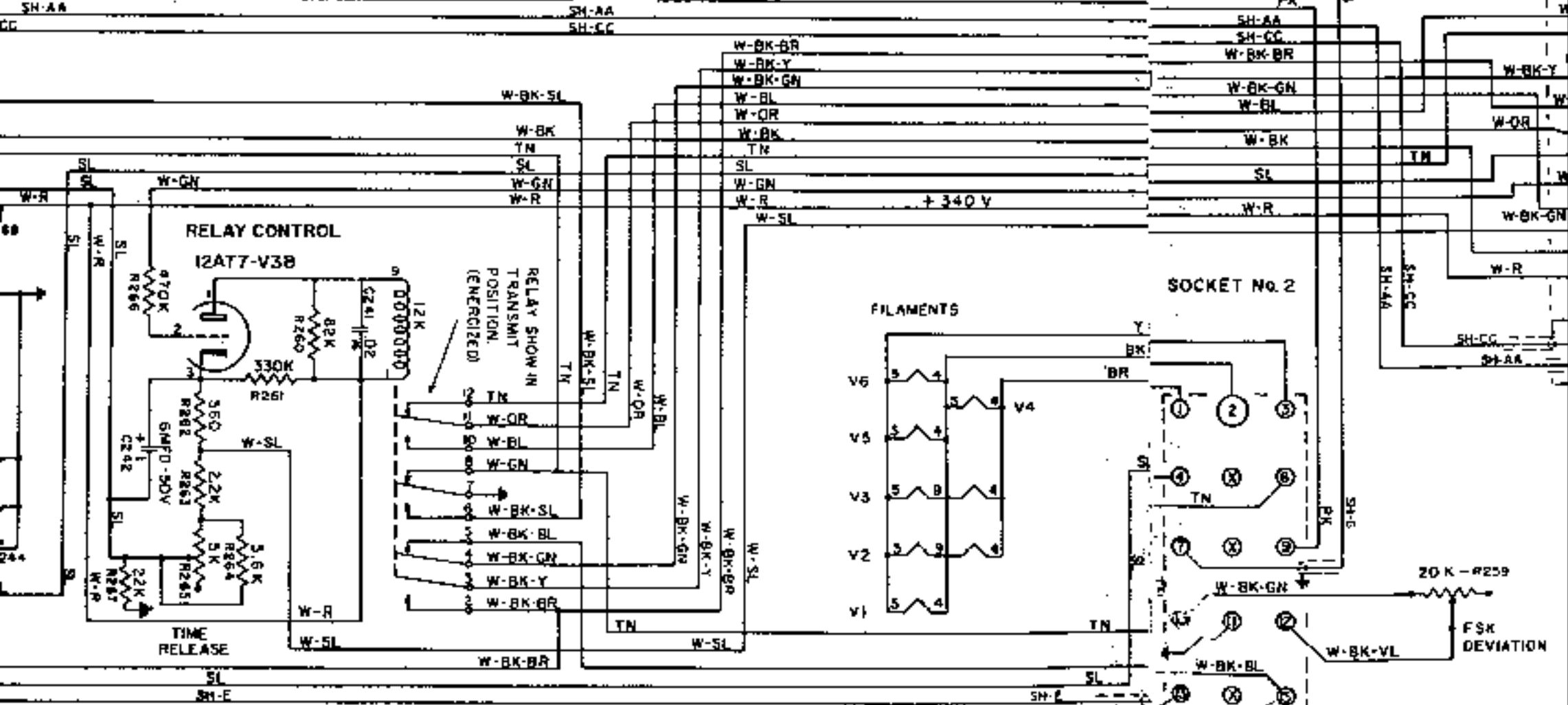
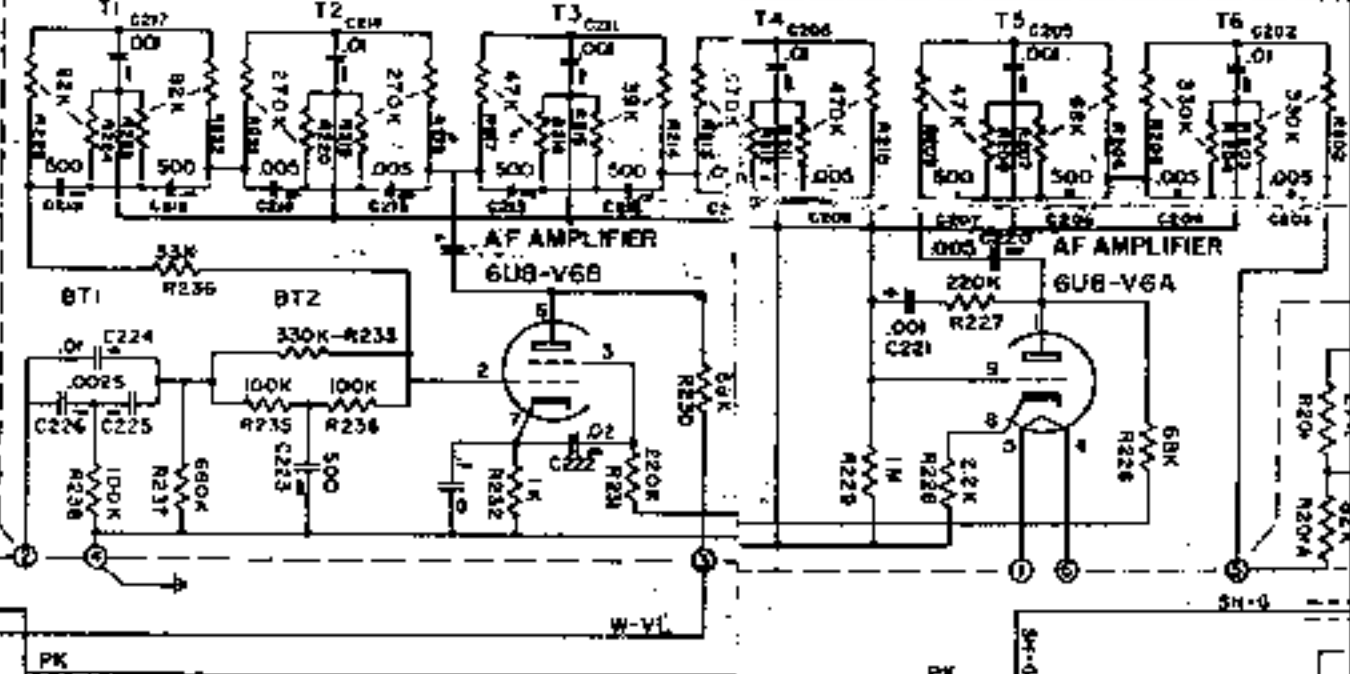



CHASSIS No. 5 - VFO

CHASSIS No. 2 - AF

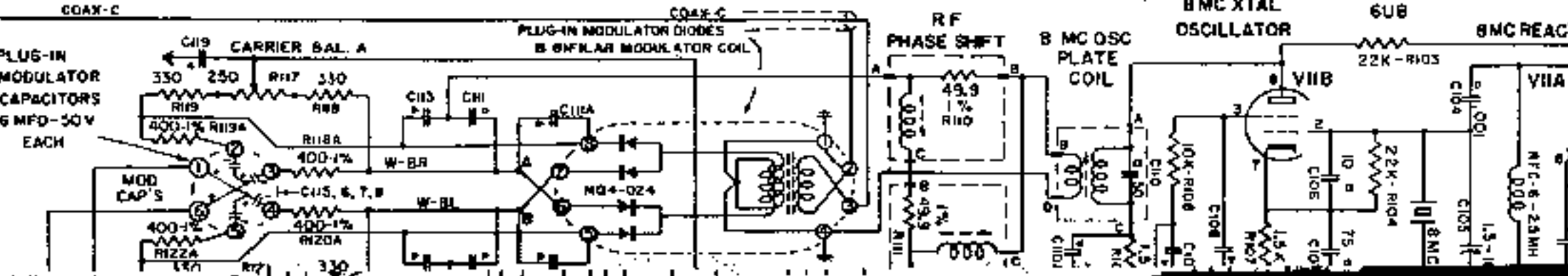
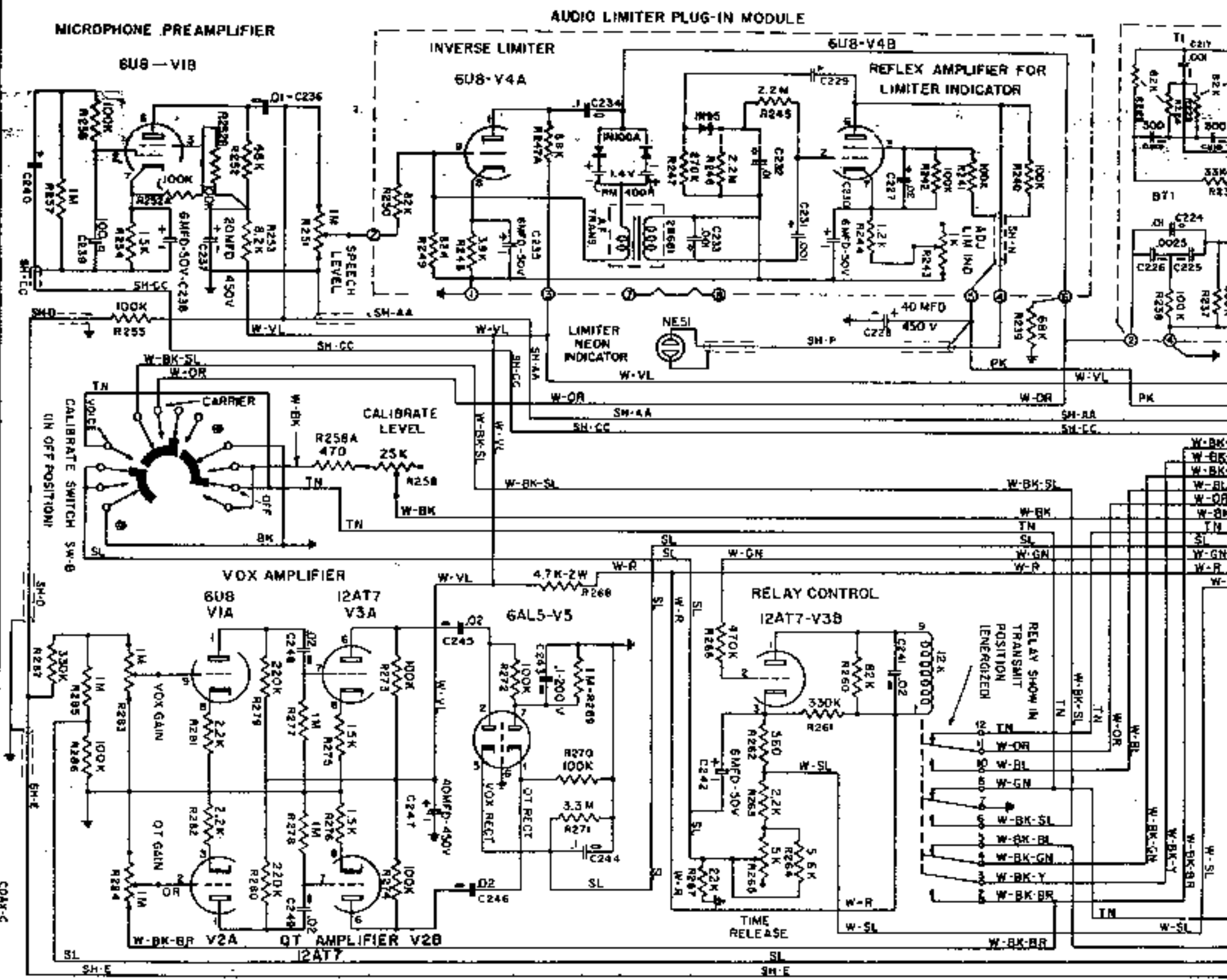
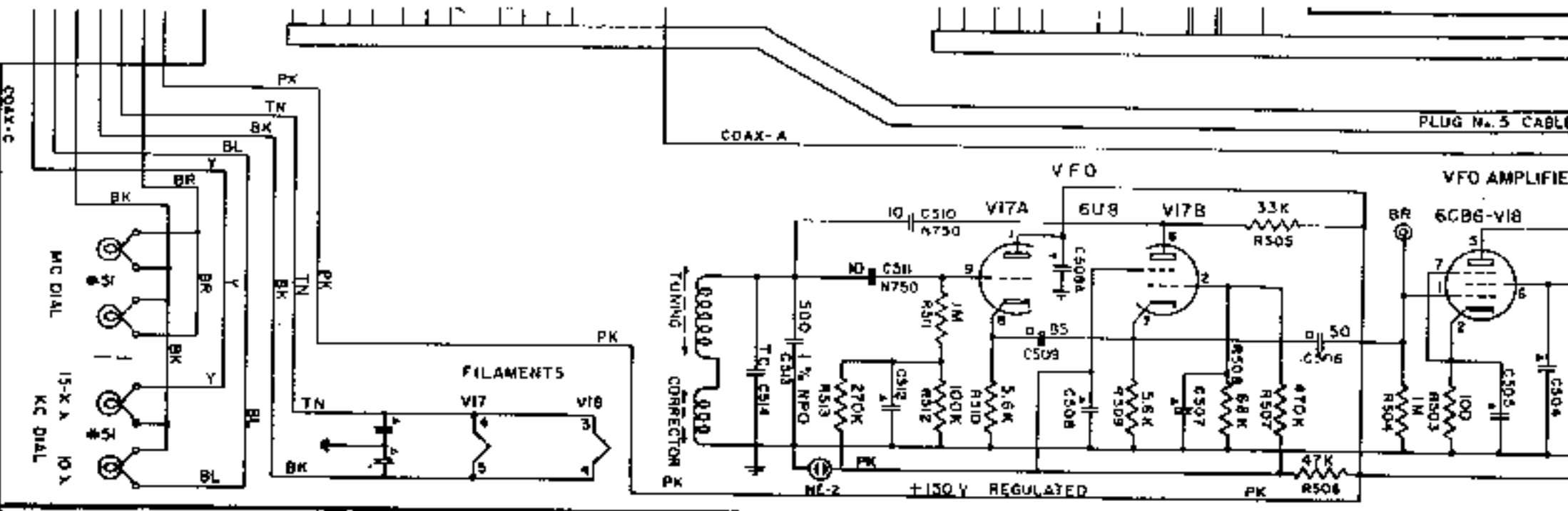



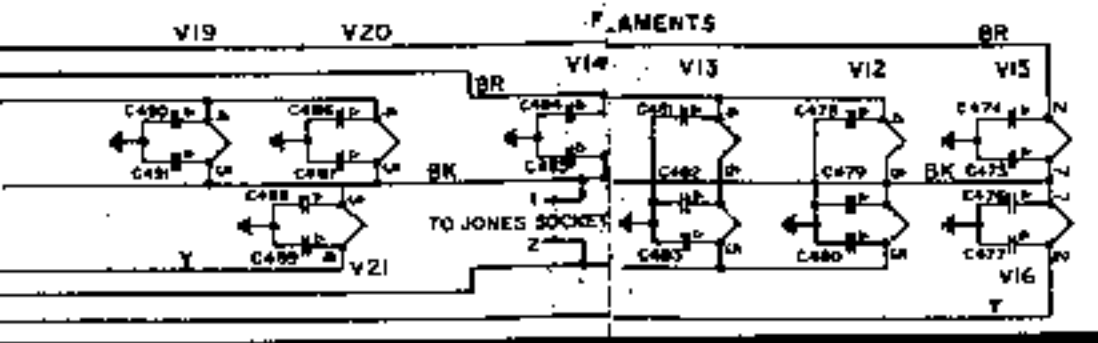
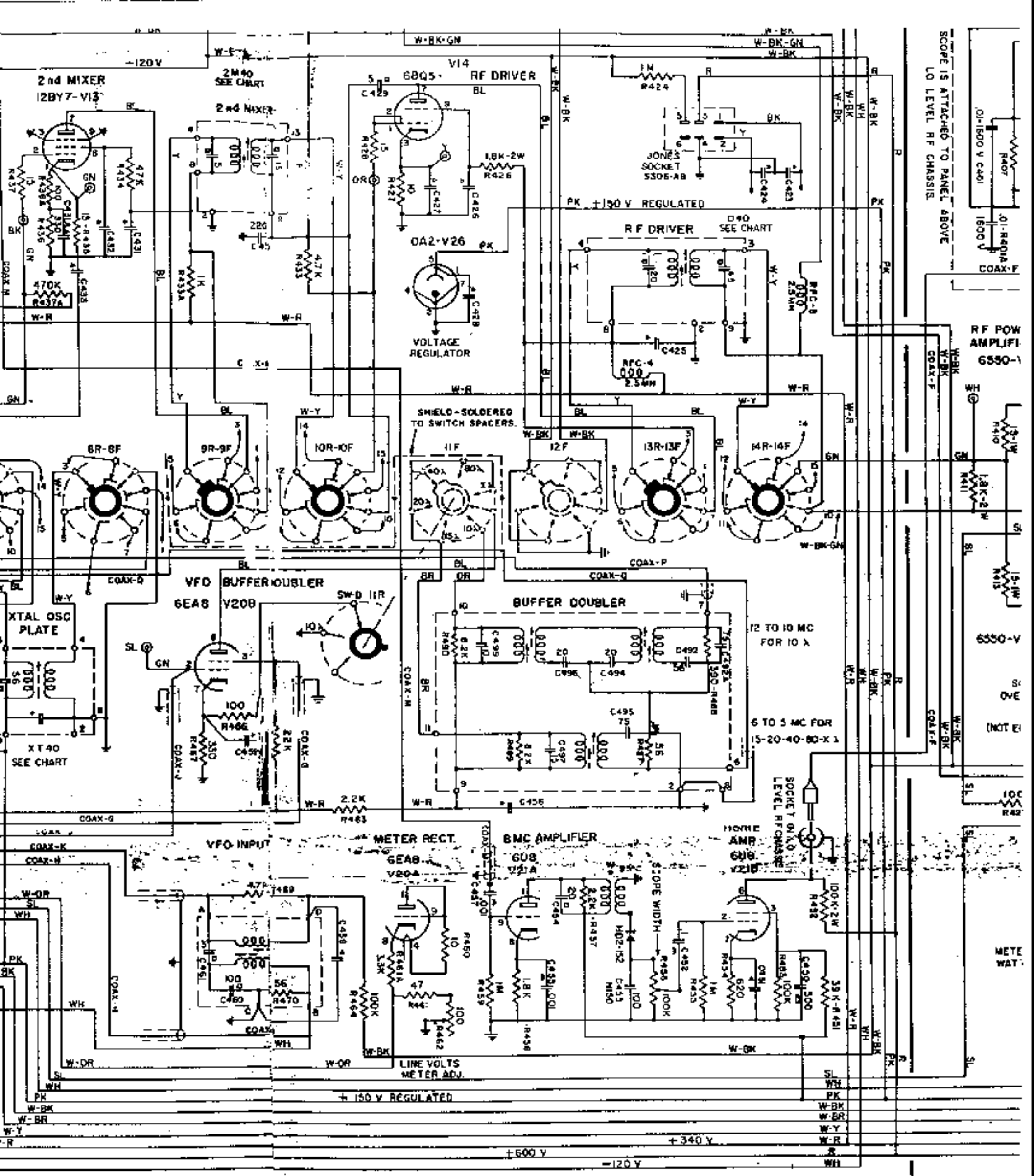

15	W-VI
13	W-Y #16
12	WH
11	W-BK
10	W-Y #16
9	W-BR
7	W-Y
6	Y
3	2Y

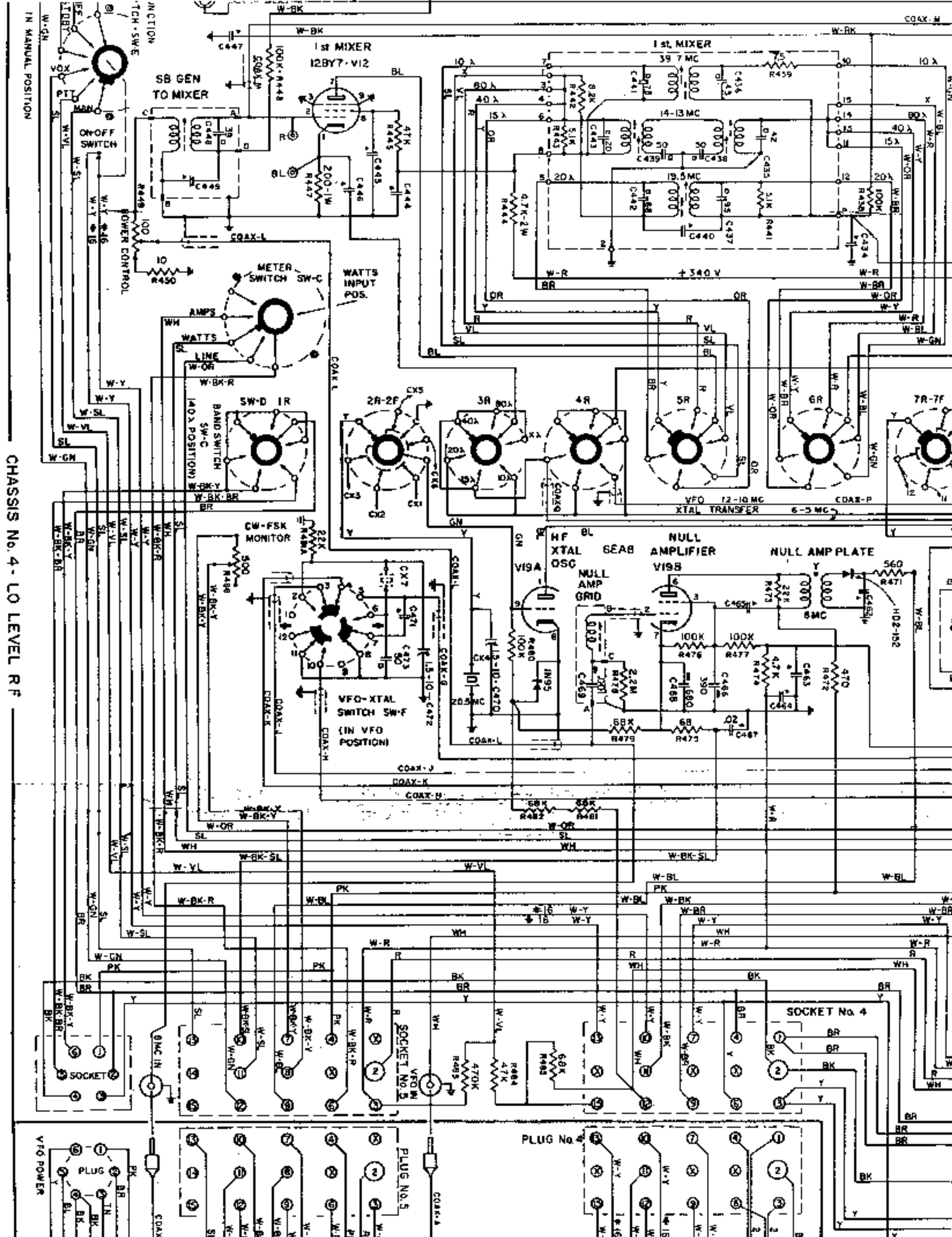

CHASSIS No. 4 - LO LEVEL RF

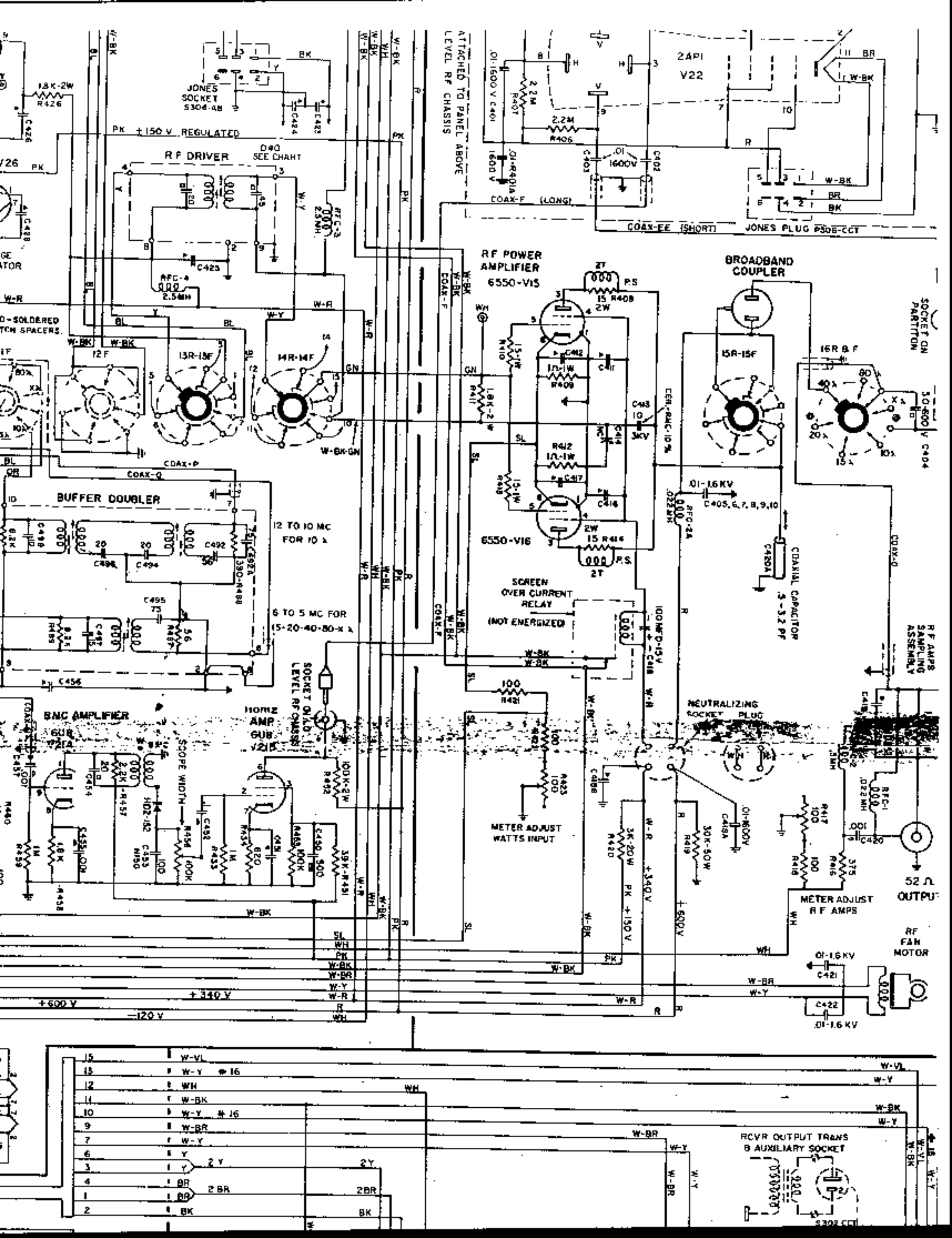

ATTACHED TO PANEL ABOVE  
LEVEL RF CHASSIS

PK +150 V REGULATED

RF DRIVER

RF POWER  
AMPLIFIER  
6550-VIS

BROADBAND  
COUPLER

BUFFER DOUBLER

RMC AMPLIFIER

HORIZ  
AMP  
SUB

METER ADJUST  
WATTS INPUT

NEUTRALIZING  
SOCKET PLUG

METER ADJUST  
RF AMPS

RCVR OUTPUT TRANS  
B AUXILIARY SOCKET

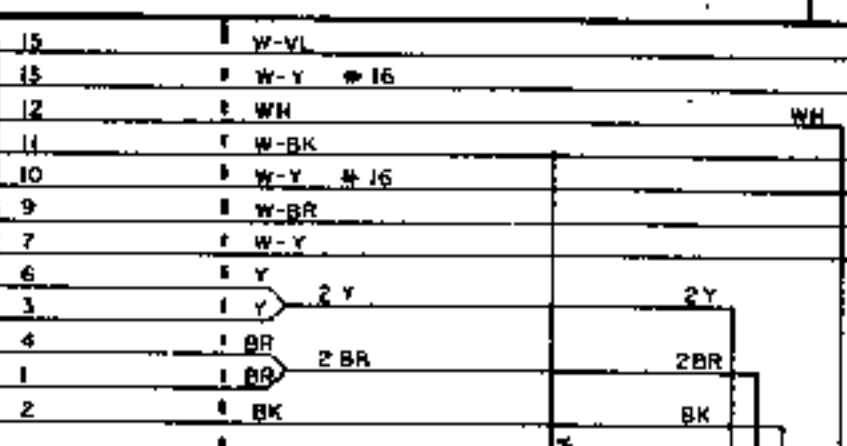

SOCKET ON  
PARTITION  
30-800 V C404

RF AMPS  
SAMPLING  
ASSEMBLY

52 Ω  
OUTPUT

RF  
FAN  
MOTOR

RCVR OUTPUT TRANS  
B AUXILIARY SOCKET









