

INSTRUCTION MANUAL

Clegg

THOR 6, TRANSCEIVER RF

CLEGG LABORATORIES DIVISION
Squires-Sanders, Inc.
ROUTE 53, MOUNT TABOR, N. J.

WARRANTY

Squires-Sanders, Inc. warrants the equipment herein described to be free from defective material or factory workmanship and agrees to remedy any such defect, by repair or replacement at the company's option, which in the company's judgement is a fault of its manufacturing, for a period of 180 days from date of original purchase and provided that the owner warranty registration card is returned within 10 days after purchase, and provided further that the equipment is returned to the factory or its authorized representative in accordance with Squires-Sanders instructions and with transportation charges prepaid.

This warranty specifically excludes accessories, including vacuum tubes, not of the company's manufacture except to the extent such items may be warranted to Squires-Sanders by the manufacturer thereof. Warranty shall be invalid in the event of (a) unauthorized repair or alteration, (b) misuse, negligence or accident, (c) connection, installation or operation in a manner at variance with instruction manual, or (d) alteration, disfigurement or removal of serial number.

Squires-Sanders reserves the right to make any change in design, or to make addition to, or improvements in, its products without assuming any obligation to install them in its products previously manufactured.

This warranty is in lieu of all other warranties expressed or implied and no representative or person is authorized to assume for us any other liability in connection with the sale of our products.

Squires-Sanders, Inc.

475 WATCHUNG AVENUE, WATCHUNG, N.J. • 755-0222

Notes: In the event of damages resulting from shipment, a direct claim against the common carrier must be made by the customer.

In the event that warranty service is required, both units of a two piece equipment should be returned (to the factory or the warranty service station). For example, a power supply or combination modulator/supply must accompany the RF unit.

IMPORTANT

Occasionally purchasers of Clegg amateur gear neglect to register their equipment with the factory. This is a serious mistake as prompt factory registration provides these advantages to the owner.

- 1) It assures you of full factory performance under the terms of the Warranty.
- 2) From time to time certain circuit and component modifications are made which result in significant improvement in performance. Such modification information is promptly sent to registered owners.
- 3) In the event of theft or loss by fire, this record will be incontrovertable evidence for your insurance company.

Be sure when sending in registration cards to include serial numbers (of all units where more than a single unit of equipment is purchased). Also, be sure to include date of purchase and the name of the dealer from whom purchased.

C A U T I O N

READ THOROUGHLY BEFORE PLACING YOUR THOR 6 IN OPERATION

You are now the owner of a new Clegg Thor 6 transceiver. This finely engineered piece of gear will give you years of outstanding performance on the amateur six meter band. To realize its full potential, a few simple "Dos" and "Dont's" carefully observed as follows will assure long efficient service and maximum protection for costly components.

Take time to read this manual carefully and completely before attempting to put the rig on the air.

Study the units and controls until you are completely familiar with all functions as described in the manual.

Be sure that the AC power outlet is of adequate capacity to meet the power requirements of the unit.

Be sure to use an adequately shielded microphone of good quality. (See #III - Modulation page 6)

Be sure that your antenna is correctly assembled, properly installed and matched carefully to the transmitter's output. For efficient transfer of output power, the antenna's VSWR must not exceed a ratio of 2.0 : 1.0. Reflected power in excess of this level can seriously damage such components as the final amplifier tube. If you are not absolutely sure of your antenna VSWR, buy or borrow a good VSWR bridge such as the Bendix (Jones-Micro-Match), Sierra or Bird, and check your line carefully. A well matched antenna will pay big dividends on both transmit and receive.

Never turn on the transmitter section without first having a good antenna or suitable dummy load connected to antenna terminal, as severe damage may result.

Never fail to observe all safety precautions as outlined in the ARRL Handbook.

NOTE: NO EXTERNAL ANTENNA RELAY SHOULD BE USED WITH THE THOR AS ANTENNA SWITCHING IS ACCOMPLISHED INTERNALLY BY RELAY K I B. . .

C L E G G T H O R 6

OWNERS MANUAL

I. INSTALLATION

- A. After carefully unpacking both shipping containers, the Thor RF unit and the AC modulator/power supply unit should be examined for visible shipping damage. If either unit has been damaged in shipping, notify transportation company at once. Retain all shipping cartons and packing material.
- B. The RF unit will normally be located on the operating desk at a position where all controls are readily accessible to the operator. Top of unit should not be covered or otherwise obstructed since tube and component life will be materially shortened.

The modulator/power supply unit can be located in any convenient, well ventilated space remote from the actual operating position. Cables are provided for 10 feet of separation between the RF and modulator/power supply unit. Access to the Mod/PS is required only when switching transmitting mode from AM to CW (or vice versa); all other operating functions are remotely controlled by the RF unit.

- C. Cable connection to be made:
- 1) Interconnecting power cable should be connected between matching receptacles of both units.
 - 2) Antenna connection should be made to coaxial connector at center rear of RF unit.
 - 3) Speaker (3 to 6 ohm) via RCA phono jack, (supplied at rear of RF unit).
 - 4) Microphone (either push-to-talk or otherwise) should be high impedance, medium output crystal, dynamic or ceramic. Chassis microphone connector is a Switchcraft 12B and mating connector (attached to mike cable) should be a Switchcraft #267 or equivalent.
- D. Connect AC power cable from MOD/PS unit to a suitable source of 110 to 125 volt, 60 cycle power with not less than 4 amp capacity. Prior to making AC connection, make sure that controls on RF unit are set as follows:

AC - OFF position on VOLUME CONTROL
RECEIVE - position on SEND-RECEIVE-ANL Switch
RECEIVE AM - position on INJECTION CONTROL (Function Switch).

- E. Advance VOLUME control clockwise from AC OFF position and notice that pilot light lights.
- F. It is normal for S meter to swing up to full scale initially then gradually return to near ZERO position during receiver warm-up.

II. OPERATING INSTRUCTIONS

A. PANEL CONTROL AND INDICATOR FUNCTIONS - RF UNIT

- 1) AC OFF - VOLUME CONTROL performs the conventional panel indicated functions. When control is turned completely counter-clockwise to the AC OFF position, all power is removed from both the RF and MOD/PS chassis.
- 2) VFO - CRYSTAL SWITCH - serves several purposes.
 - a) When transmitting in the VFO position, the transmitter frequency is controlled by the receiver tuning dial and the transmitted signal frequency will be within a few cycles of that of the station to which the receiver is tuned.
 - b) When transmitting in the CRYSTAL position, the transmitter frequency is controlled in the conventional manner by the use of a suitable crystal (inserted into CRYSTAL receptacle on the panel). Receive tuning then has no effect on transmitter frequency.
 - c) When receiving, the VFO-CRYSTAL switch may be employed (in conjunction with the FUNCTION switch) to spot frequency oscillator for copying CW of single sideband.
- 3) SEND - RECEIVE - ANL (3-position, lever switch)
 - a) SEND position actuates transmitter and is in parallel with microphone push-to-talk control. (See under FUNCTION switch #5) details on AMPLIFIER - OFF).
 - b) RECEIVE position switches THOR to normal receive functions with noise limiter out of circuit.
 - c) ANL position is identical to RECEIVE position, except that the automatic noise limiter is engaged.

NOTE: For push-to-talk operation with SEND-RECEIVE function performed by a suitable microphone switch, the THOR may be left in either RECEIVE or ANL positions as desired - - - never in SEND!

- 4) MAIN TUNING DIAL serves function of tuning receiver over calibrated 50 to 52 mc range and of simultaneously shifting transmitter frequency to coincide with incoming receiver frequencies (when CRYSTAL - VFO switch is in VFO position).

NOTE #1: The THOR has been factory aligned for transmitter VFO operation over the 50 to 51.3 mc range. When operation above 51.3 mc is desired, it is recommended that CRYSTAL control be employed except in emergencies. Some TVI and reduced modulation effectiveness may be experienced when VFO is employed at the upper end of the band.

NOTE #2: MAIN TUNING DIAL calibration may be realigned to compensate for component aging by adjusting C42 trimmer (#10 front panel) with an insulated screw driver to ZERO beat with a signal of known frequency.

- 5) FUNCTION SWITCH (5 position control marked INJECTION)

- a) RECEIVE AM is the normal position to be employed for receiving AM phone signals regardless of whether transmitter is operating on AM or CW. (Transmit mode controlled by AM-CW switch on MOD/PS unit).
- b) The INJECTION control actuates either an internal 10.7 mc crystal oscillator as a BFO for copying CW or SSB or the transmitter crystal oscillator for spotting the frequency of the transmitter when crystal control is employed. The three INJECTION positions provide means of varying the amplitude of the BFO or SPOT signal to meet specific requirements.
- c) AMP OFF position disconnects the high voltage power supply used for the final amplifier and modulator. It is employed principally for service and alignment of the broad band circuits in the transmitter and normally serves no operating function.

- 6) PANEL METER

The panel meter serves the dual functions of:

- a) Calibrated S meter on RECEIVE
- b) A relative output meter for transmitter loading

The meter calibration has been factory adjusted so that approximately 1/2 of full scale will be indicated at normal carrier output WHEN ANTENNA LOAD IS 48 to 55 OHMS with 1:1 SWR.

- 7) PANEL LAMP

- 8) CRYSTAL SOCKET accepts FT-243 or similar type crystal holders. 8.2 mc or 12.5 mc crystal may be used.

9) AMPLIFIER TUNE and AMPLIFIER LOAD are the only two controls required for tuning transmitter when changing frequency. The final amplifier stage employs a PI type network and both controls should be adjusted for maximum meter reading on TRANSMIT.

10) Screw driver adjust trimmer.

B. REAR APRON CONTROLS AND JACKS (RF UNIT)

- 1) MICROPHONE jack accepts Switchcraft type #267 plug with push-to-talk provision. The base of the receptacle is grounded; the ring portion is the microphone connection, and the tip connection is the push-to-talk terminal.
- 2) SPEAKER JACK is of the phono plug type and the THOR is designed to match a 4 ohm speaker voice coil. Satisfactory performance can be obtained with speaker impedances of 3 to 8 ohms.
- 3) MICROPHONE GAIN CONTROL varies audio gain of speech amplifier to accommodate a wide range of microphone characteristics and speaking levels.
- 4) S Meter ZERO ADJUST provides means of resetting S meter to ZERO to compensate for varying line voltage and aging of tubes.
- 5) HEADPHONE JACK accommodates a standard two conductor PL-55 type plug. Insertion of plug with high impedance headphones disables speaker but it is necessary to put a shorting plug (phono type) into speaker jack in order for the headphones to become operative if no speaker is connected.
- 6) ANTENNA CONNECTOR
- 7) POWER CABLE CONNECTOR

C. CONTROLS and JACKS - MOD/PS

- 1) FUSE RECEPTACLE accommodates 3 AG type fuses. A 3 ampere 125 volt, SLOW-BLOW type only should be used as a replacement.
- 2) KEY JACK accommodates the standard two conductor PL-55 type plug.
- 3) CW - AM SELECTOR SWITCH provides switching to select either mode of operation of the TRANSMITTER.
- 4) MODULATOR CURRENT JACK is a standard phono receptacle permitting the operator to plug in a 100 MA DC milliammeter for monitoring relative modulation level.

III. SPECIFICATIONS

A. FREQUENCY RANGE

- 1) RECEIVE - 49.8 to 52.2 mc (calibrated from 50.0 to 52.0 mc in 50 kc steps; readable to 10 kc or less).
- 2) TRANSMIT - 49.8 to 54.0 mc (any 2.3 mc portion). As supplied from factory, the transmitter may be VFO controlled, synchronized with receiver over the entire receive range.

The THOR accommodates both 8.2 mc and 12.5 mc range crystals (1/6 and 1/4 of operating frequency respectively). Where transmitter operation is planned outside the 49.8 and 52.1 mc range for which factory adjustments have been made, it is necessary that the exciter stages be realigned. Service data sheet on this is available from factory.

B. FREQUENCY STABILITY: (RECEIVER AND TRANSMITTER VFO)

- 1) Initial warm-up drift at room temperature less than 15 kc during first 10 minutes of operation exclusive of 3 minutes warm-up period.
- 2) Short time stability over any one hour period (after initial 15 minutes warm-up) is less than 3 kc.
- 3) Long term drift is such that dial calibration will not change more than 15 kc during any 30 day period. Convenient means is furnished for periodically correcting any dial calibration error (at front panel). Adjust #10 with insulated screw driver.

C. POWER OUTPUT

The transmitter RF OUTPUT is approximately 40 watts when AC line voltage is between 115 and 118 volts and the antenna is a resistive 45 to 75 ohm load.

D. MODULATION

- 1) High level plate and screen modulation is employed with audio clipping and filtering characteristics distributed through both low and high level stages.
- 2) Under normal load and AC line voltage, modulation peaks up to 100% are readily furnished in both positive and negative direction. With sine wave input at 1000 cycles adjusted for 95% modulation, the audio characteristics are such that modulation will not be less than 75% from 500 to 2500 cycles and not more than 10% at 250 and 5000 cycles.
- 3) Microphone output level of 100 MV at 1000 cycles is sufficient to produce 100% modulation.

E. RECEIVER SENSITIVITY

- 1) A .2 microvolt CW signal can be detected with more than 3 db signal to noise ratio.
- 2) An incoming .5 microvolt, 80% modulated AM signal will produce a readable signal under normal conditions.
- 3) Typical receiver noise figure is less than 3 db.
- 4) A signal of approximately 25 microvolts produces an S meter reading of S9. All S units are separated by an approximate 2 to 1 signal level (6 db).
- 5) A 400 cycle modulated signal of 1 microvolt or more will produce more than 1.5 watts audio output into a 3 to 5 ohm load.

F. RECEIVER SELECTIVITY

6 db down points: 5± 2 KC
50 db down points: 12± KC

G. RECEIVER IMAGE, SPURIOUS AND "IF" RESPONSES

All spurious responses are down more than 60 db. In cases where local TV or FM signals between 54 and 150 MC are not rejected sufficiently an additional 45 to 75 db rejection may be achieved by insertion of a GLEGG MODEL 372 LO PASS FILTER in the transmission line.

H. AVC Characteristics are such that an input signal variation from 1 microvolt to 2 millivolts will not produce an output change of more than 10 db.

I. TRANSMITTER SPURIOUS OUTPUTS

- 1) Spurious outputs and harmonics between 54 and 250 mc are all down more than 50 db when the THOR is operating on VFO between 50 and 51 mc. An additional reduction of 10 db is attained when crystal control is employed.
- 2) In those isolated cases where harmonic radiation is in excess of that required to meet local TV conditions (fringe areas), the addition of the GLEGG MODEL 372 LO PASS FILTER will reduce any spurious output well below levels imposed by FCC requirements.

IV. PRINCIPLE OF OPERATION - RECEIVE

A. Signals between 50 and 52 mc are amplified in the grounded grid Nuvistor RF amplifier stage, VI (6CW4). Tuned circuits consisting of L1, L2, and L3 and related components are designed to provide essentially flat response between 50 and 52 mc, and to reject signals outside of this range.

- B. Variable frequency oscillator, V6A (6DJ8), tunes between 39.3 and 41.3 mc. Regulated voltage, stable components, care in construction and nature of design furnish stability of unusually high degree. V6B is employed as a cathode follower to provide isolation between other circuits and the VFO.
- C. First MIXER, V2 (6EH7) combines the VFO output and the RF amplifier output in a conventional mixer circuit selecting the 10.7 mc component. (For instance, when the VFO is tuned to 39.5 mc a 50.2 mc input signal will heterodyne with it in such a manner to produce a 10.7 mc output).
- D. Transformers T1 and T2 combine with quartz crystals X1 and X2 to provide a selective filter circuit with little or no discrimination over a 5 kc bandwidth centered at 10.7 mc and with excellent rejection of interfering signals just outside the 5 kc passband.
- E. The two sections of V3 (6BL8) function as:
 - 1) A pentode mixer
 - 2) An 11.156 mc crystal controlled oscillator which converts the 10.7 mc filter output to 456 kc.
- F. Transformers T3 and T4 with associated capacitors produce a filter arrangement with characteristics adjusted to supplement the selectivity of the 10.7 mc crystal filter.
- G. V4 (6EH7) is a conventional 456 kc IF amplifier with sufficient gain to assure linear operation of the following detector circuit. AVC control is applied to V4 (as well as V1).
- H. V14 (12AL5) is employed as both a detector and AVC rectifier.
- I. A silicon diode, CR3 (IN645) functions as a series peak noise limiter of the automatic or self adjusting type. One pole of the SEND-RECEIVE-ANL switch shorts this diode in the RECEIVE position for normal reception.
- J. The two sections of V5 (6EM8) furnish more than 1-1/2 watts of audio output. Volume control is by R28.
- K. The calibrated S meter (M1), is arranged to indicate changes in plate current of the AVC controlled stages. R20 is furnished to reset S meter to ZERO under no signal condition.
- L. For CW or SSB reception, a 10.7 MC crystal oscillator, provided by one section of V7 furnishes a controllable (by means of S4A) amount of IF heterodyning signal.

V. PRINCIPLE OF OPERATION - TRANSMIT

- A. Two methods of establishing transmitting frequency are provided in the THOR 6.
- 1) Crystal or fixed frequency operation is by conventional crystal oscillator and harmonic amplification wherein V7B functions as a crystal oscillator - harmonic generator with 25 mc output. Design is such that crystals may be at 1/3 or 1/2 of the desired 25 mc frequency. V8 (12BA7) then functions as a frequency doubler to 50 mc.
 - 2) VFO Operation is by:

Heterodyne generation in V8 (12BA7) wherein the output of a 10.7 mc crystal oscillator (V7A) is mixed with the output of the 39.3 to 41.3 mc VFO. The sum of these two frequencies is selected in the 12BA7 plate circuit and will automatically coincide with the 50 to 52 mc frequency to which the receiver is tuned.
- B. The plate circuit of the 12BA7 and the grid circuit of the first 50 mc AMP, V9 (6DJ8) are broad banded over a 2 mc range. These circuits, and all the following circuits in the transmitter, function identically regardless of whether VFO or CRYSTAL control is employed.
- C. The first 50 mc AMPLIFIER (6DJ8) in a conventional cascode circuit drives V10 (7558) as a Class "C" 50 mc second amplifier.
- D. V11 (6883) is a conventional Class C amplifier with provision for modulation, both plate and screen voltage. Normal input when operated with the Model 417 THOR MOD/PS is 560 watts at 110 ma resulting in a plate input of approximately 62 watts. A well designed PI network tank circuit utilizes C72, L13, and C74 furnishing output efficiency in the order of 65% and typical measured power output of more than 40 watts.
- E. V12 (12AX7) serves the dual purpose of amplifying the microphone output to sufficient level and low impedance (by means of cathode follower action of V12B) to drive the low impedance input stage of the 417 MOD/PS unit. Gain is adjustable by R68 (at rear of receiver RF chassis) to accommodate various microphone and voice characteristics.

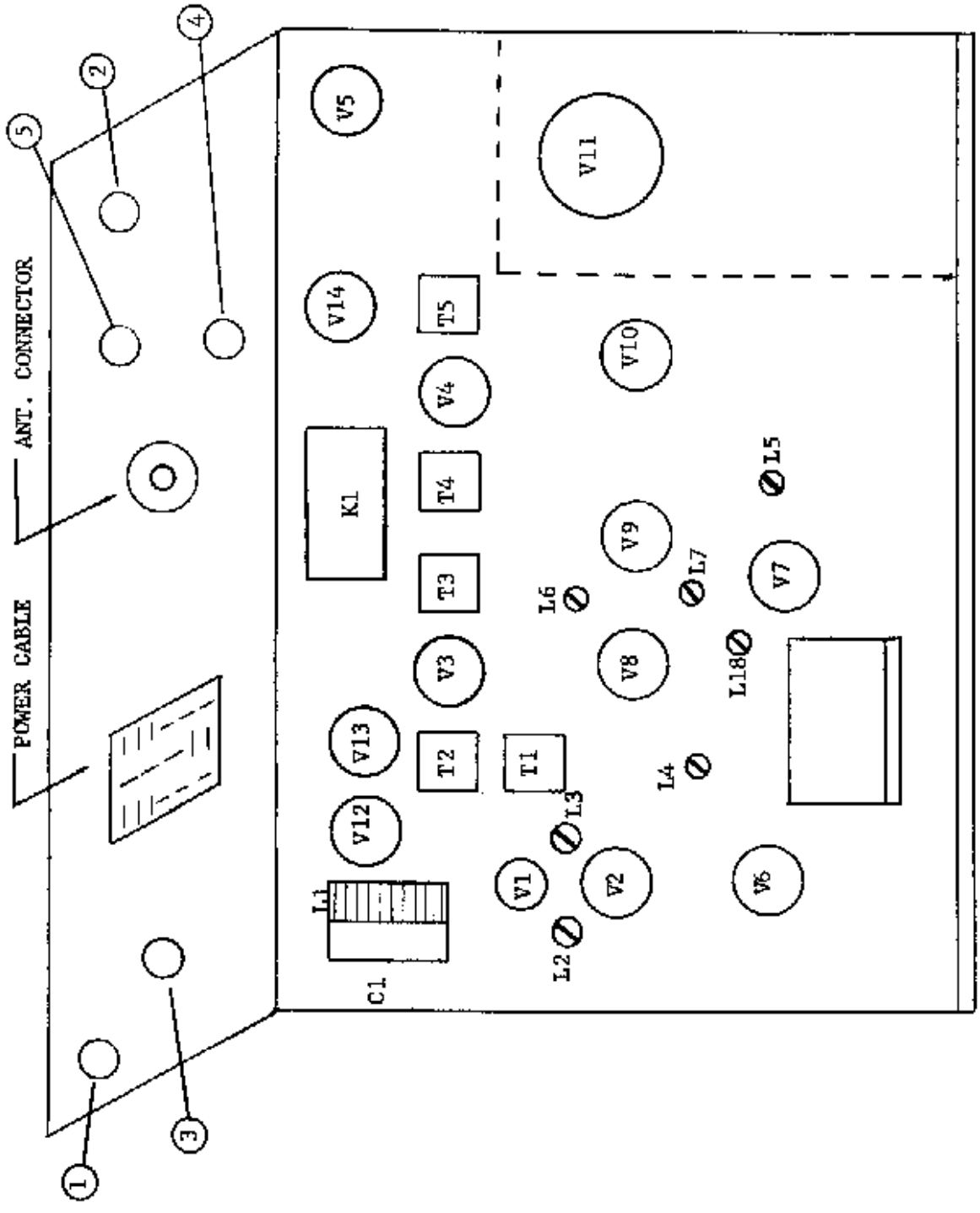

RECEIVER AND RF CHASSIS AND REAR APRON PARTS LAYOUT

INTERCONNECTING CABLE

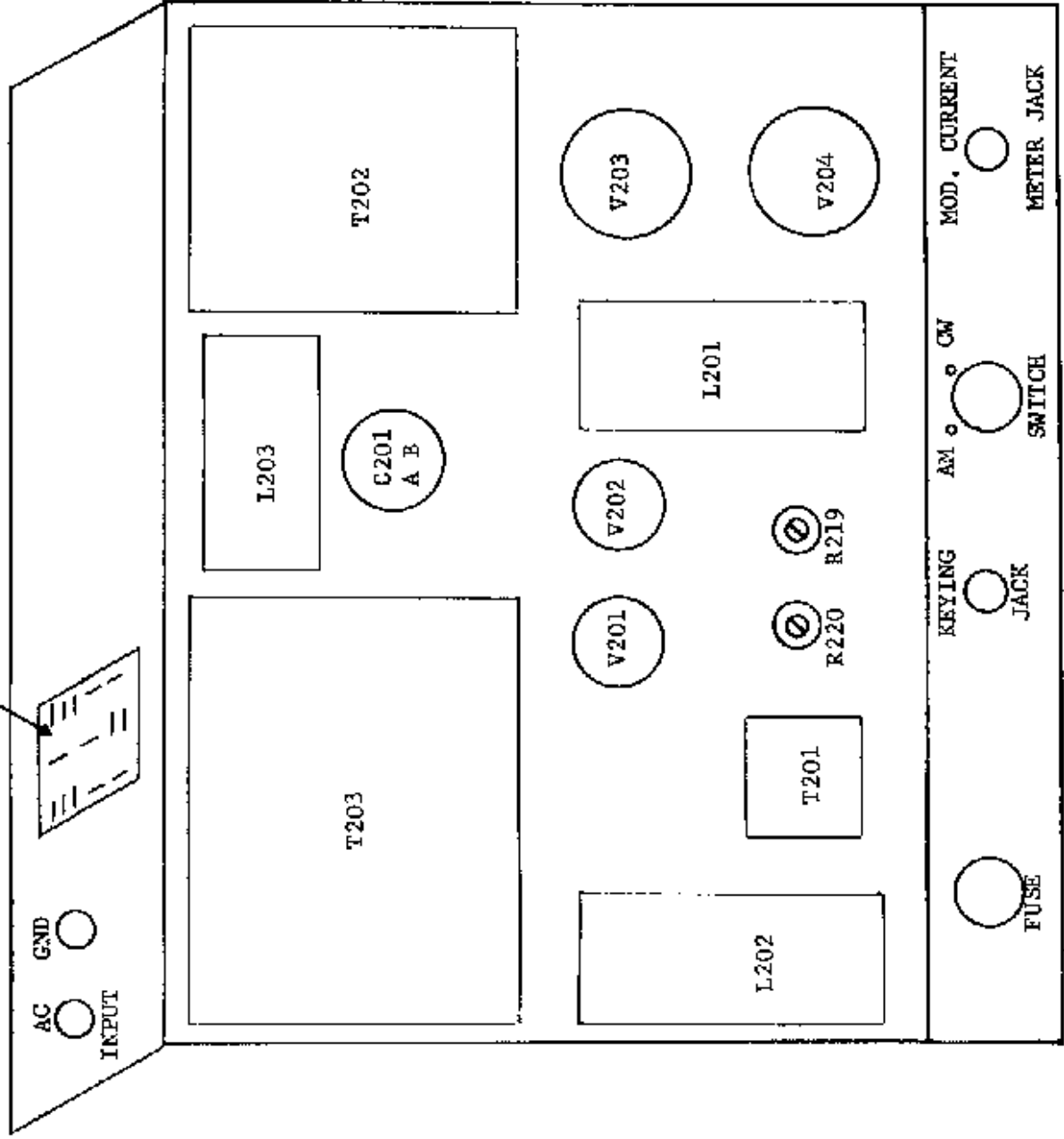

MODULATOR/POWER SUPPLY - FRONT - TOP - REAR PARTS LAYOUT

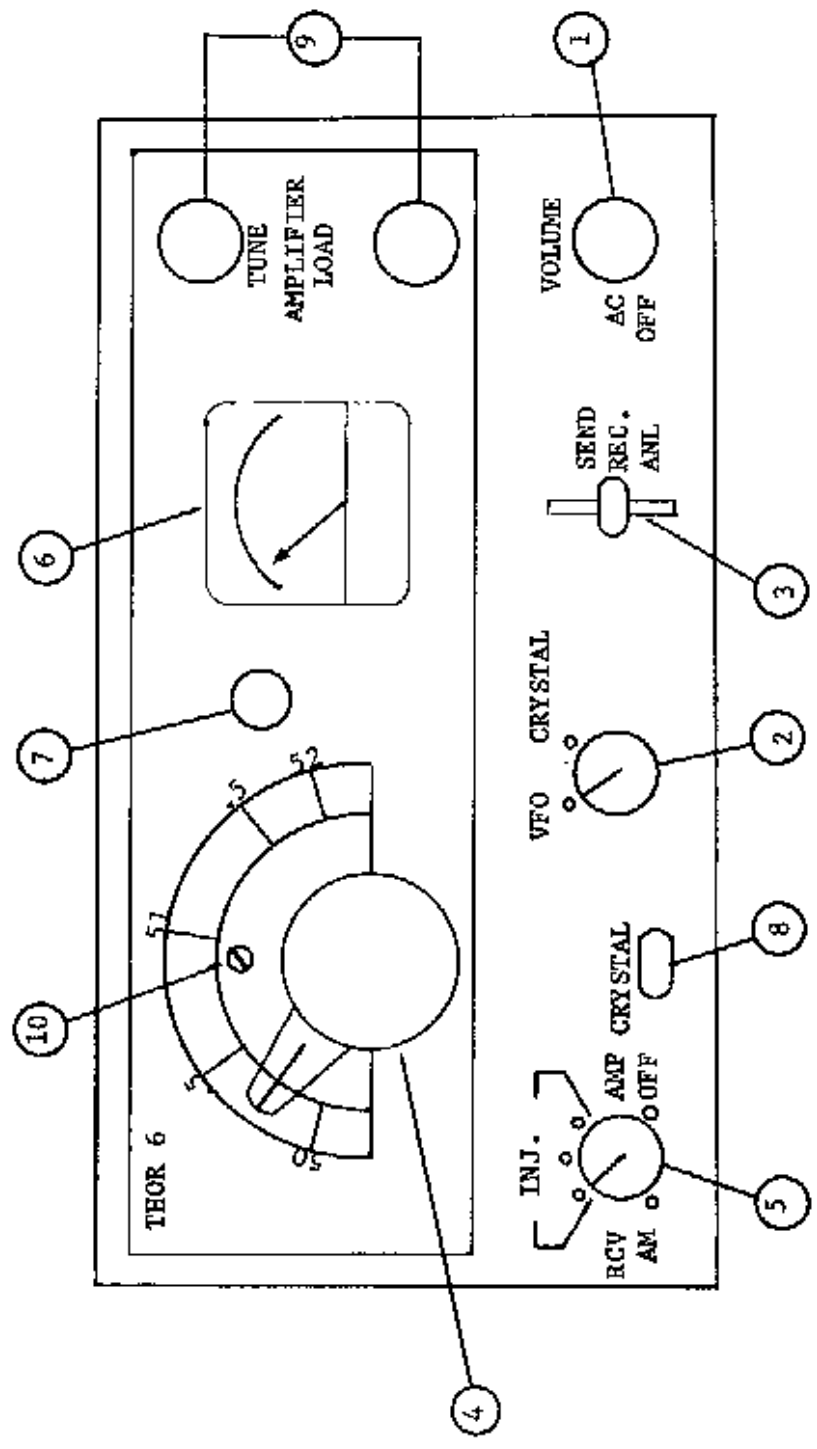

FRONT PANEL LAYOUT

THOR 6 - TRANSCEIVER

PARTS LIST

THOR TRANSCEIVER RF and THOR 6, MODEL 417 AC POWER SUPPLY/MODULATOR

ITEM	DESCRIPTION	PART NUMBER	ITEM	DESCRIPTION	PART NUMBER
<u>THOR 6, TRANSCEIVER RF</u>					
C1	CAPACITOR, NEGATIVE 500, 7-45 PF	116-106	CR1	DIODE, GERMANIUM, TYPE 1N34A	144-001
C2	CAPACITOR, DISC CERAMIC, 2200 PF	102-043	CR2	DIODE, SILICON, TI 56/1N645	142-001
C3	CAPACITOR, DISC CERAMIC, 2200 PF	102-043			
C4	CAPACITOR, DISC CERAMIC, 2.2 PF NPO	100-104			
C5	CAPACITOR, DISC CERAMIC, 2200 PF	102-043	I1	LAMP, NEON	153-001
C6	CAPACITOR, DISC CERAMIC, 2200 PF	102-043			
C7	CAPACITOR, DISC CERAMIC, 2200 PF	102-043	K1	RELAY	174-004
C8	CAPACITOR, DISC CERAMIC, 2200 PF	102-043			
C9	CAPACITOR, DISC CERAMIC, 2200 PF	102-043			
C10	CAPACITOR, DISC CERAMIC, 2200 PF	102-043			
C11	CAPACITOR, DISC CERAMIC, .005 MF	102-050	L1	INDUCTOR, 7 TURNS AIR COX 416 T	191-007
C12	CAPACITOR, DISC CERAMIC, 12 PF NPO	100-113	L2	INDUCTOR, 1-2 uh SLUG TUNED	182-004
C13	CAPACITOR, DISC CERAMIC, 12 PF NPO	100-013	L3	INDUCTOR, .55-1.2 uh SLUG TUNED	182-012
C14	CAPACITOR, DISC CERAMIC, 22 PF NPO	100-116	L4	COIL FORM	337-002
C15	CAPACITOR, DISC CERAMIC, 68 PF NPO	100-122	L5	INDUCTOR, 4-8 uh SLUG TUNED	182-009
C16	CAPACITOR, DISC CERAMIC, 2200 PF	102-043	L6	INDUCTOR, .55-1.2 uh SLUG TUNED	182-012
C17	CAPACITOR, DISC CERAMIC, .02 MF	102-056	L7	INDUCTOR, 1-2 uh SLUG TUNED	182-004
C18	CAPACITOR, DISC CERAMIC, .005 MF	102-050	L8	INDUCTOR, 1-2 uh SLUG TUNED	182-004
C19	CAPACITOR, DISC CERAMIC, .005 MF	102-050	L9	CHOKE, 7 uh	190-002
C20	CAPACITOR, DISC CERAMIC, 1.5 PF NPO	100-102	L10	INDUCTOR, 1.032-1.94 uh SLUG TUNED	182-010
C21	CAPACITOR, DISC CERAMIC, .005 MF	102-050	L11	CHOKE, 7 uh # 50	190-004
C22	CAPACITOR, DISC CERAMIC, 15 PF NPO	100-114	L12	CHOKE, 7 uh # 50	190-004
C23	CAPACITOR, DISC CERAMIC, .005 MF	102-050	L13	INDUCTOR, 6 TURNS #14 BTC 3/4" ID	SPECIAL
C24	CAPACITOR, DISC CERAMIC, .02 MF	102-056	L14	CHOKE, 7 uh	190-002
C25	CAPACITOR, NYLAR 125 V, .15 MF	105-305	L15	CHOKE, 120 uh	SPECIAL
C26	CAPACITOR, DISC CERAMIC, .02 MF	102-056	L16	CHOKE, 7 uh	190-002
C27	CAPACITOR, DISC CERAMIC, .02 MF	102-056	L17	INDUCTOR, 3T #18 on 10A 1 W RES	SPECIAL
C28	CAPACITOR, DISC CERAMIC, 150 PF NPO	101-000	L18	INDUCTOR, 1-2 uh SLUG TUNED	182-004
C29	CAPACITOR, DISC CERAMIC, .005 MF	102-050	L19	INDUCTOR, 8 TURNS #24 1/8" ID	SPECIAL
C30	CAPACITOR, DISC CERAMIC, .02 MF	102-056	L20	CHOKE, 7 uh	190-002
C31	CAPACITOR, DISC CERAMIC, .005 MF	102-050			
C32	CAPACITOR, ELECTROLYTIC, 1 MF, 6 V	107-001	M1	METER, S, 0-1 MA	409-001
C33	CAPACITOR, ELECTROLYTIC, 1 MF, 450 V	107-002			
C34	CAPACITOR, ELECTROLYTIC, 5 MF, 30 V	107-005			
C35	CAPACITOR, DISC CERAMIC, 1.5 PF NPO	100-102	R1	RESISTOR, COMPOSITION, 82 OHM 1/2 W 10%	223-820
C36	CAPACITOR, DISC CERAMIC, 2200 PF	102-043	R2	RESISTOR, COMPOSITION, 470 K 1/2 W 10%	223-474
C37	CAPACITOR, DISC CERAMIC, .02 MF	102-056	R3	RESISTOR, COMPOSITION, 470 K 1/2 W 10%	223-474
C38	CAPACITOR, DISC CERAMIC, 15 PF NPO	100-114	R4	RESISTOR, COMPOSITION, 5.6 K 1/2 W 10%	223-562
C39	CAPACITOR, SILVERMICA, 99 PF	104-111	R5	RESISTOR, COMPOSITION, 15 K 2 W 10%	223-153
C40	CAPACITOR, VARIABLE, 7-16 PF	100-110	R6	RESISTOR, COMPOSITION, 100 K 1/2 W 10%	223-104
C41	CAPACITOR, DISC CERAMIC, 5.8 PF NPO	100-010	R7	RESISTOR, COMPOSITION, 330 OHM 1/2 W 10%	223-331
C42	CAPACITOR, VARIABLE, 2.3 - 14.2 PF	105-027	R8	RESISTOR, COMPOSITION, 22 K 1/2 W 10%	223-223
C43	CAPACITOR, CERAMIC TUBULAR, 120 PF NPO	100-113	R9	RESISTOR, COMPOSITION, 330 OHM 1/2 W 10%	223-331
C44	CAPACITOR, DISC CERAMIC, 12 PF NPO	100-113	R10	RESISTOR, COMPOSITION, 100 K 1/2 W 10%	223-104
C45	CAPACITOR, CERAMIC TUBULAR, 120 PF NPO	105-027	R11	RESISTOR, COMPOSITION, 330 OHM 1/2 W 10%	223-331
C46	CAPACITOR, DISC CERAMIC, 15 PF NPO	100-114	R12	RESISTOR, COMPOSITION, 22 K 1/2 W 10%	223-223
C47	CAPACITOR, DISC CERAMIC, 220 PF	102-043	R13	RESISTOR, COMPOSITION, 33 K 1/2 W 10%	223-333
C48	CAPACITOR, DISC CERAMIC, .02 MF	102-056	R14	RESISTOR, COMPOSITION, 220 K 1/2 W 10%	223-224
C49	CAPACITOR, DISC CERAMIC, 2200 PF	102-043	R15	RESISTOR, COMPOSITION, 1 K 1/2 W 10%	223-102
C50	CAPACITOR, DISC CERAMIC, 4.7 PF NPO	100-108	R16	RESISTOR, COMPOSITION, 100 K 1/2 W 10%	223-104
C51	CAPACITOR, DISC CERAMIC, 4.7 PF NPO	100-108	R17	RESISTOR, COMPOSITION, 390 OHM 1/2 W 10%	223-391
C52	CAPACITOR, DISC CERAMIC, 2200 PF	102-043	R18	RESISTOR, COMPOSITION, 22 K 1/2 W 10%	223-223
C53	CAPACITOR, DISC CERAMIC, 15 PF NPO	100-114	R19	RESISTOR, COMPOSITION, 33 K 1 W 10%	223-333
C54	CAPACITOR, DISC CERAMIC, 33 PF NPO	100-118	R20	RESISTOR, COMPOSITION, 15 K VARIABLE	240-004
C55	CAPACITOR, DISC CERAMIC, 27 PF NPO	100-117	R21	RESISTOR, COMPOSITION, 10 K 1/2 W 10%	223-103
C56	CAPACITOR, DISC CERAMIC, 47 PF NPO	100-120	R22	RESISTOR, COMPOSITION, 3.3 K 1 W 10%	223-332
C57	CAPACITOR, DISC CERAMIC, 2200 PF	102-043	R23	RESISTOR, COMPOSITION, 1.2 MEG 1/2 W 10%	223-125
C58	CAPACITOR, DISC CERAMIC, 2200 PF	102-043	R24	RESISTOR, COMPOSITION, 100 K 1/2 W 10%	223-104
C59	CAPACITOR, DISC CERAMIC, 100 PF N-1500	100-801	R25	RESISTOR, COMPOSITION, 1.2 MEG 1/2 W 10%	223-125
C60	CAPACITOR, DISC CERAMIC, 2200 PF	102-043	R26	RESISTOR, COMPOSITION, 1.2 MEG 1/2 W 10%	223-125
C61	CAPACITOR, DISC CERAMIC, 4.7 PF NPO	100-108	R27	RESISTOR, COMPOSITION, 330 K 1/2 W 10%	223-334
C62	CAPACITOR, DISC CERAMIC, 2200 PF	102-043	R28	RESISTOR, COMPOSITION, 1 MEG VARIABLE WITH SWITCH	745-001
C63	CAPACITOR, DISC CERAMIC, 2200 PF	102-043	R29	RESISTOR, COMPOSITION, 2.2 K 1/2 W 10%	223-222
C64	CAPACITOR, DISC CERAMIC, 33 PF NPO	100-118	R30	RESISTOR, COMPOSITION, 220 K 1/2 W 10%	223-224
C65	CAPACITOR, DISC CERAMIC, 2200 PF	102-043	R31	RESISTOR, COMPOSITION, 680 K 1/2 W 10%	223-684
C66	CAPACITOR, DISC CERAMIC, 2200 PF	102-043	R32	RESISTOR, COMPOSITION, 600 OHM 2 W 10%	223-681
C67	CAPACITOR, DISC CERAMIC, 47 PF NPO	100-120	R33	RESISTOR, COMPOSITION, 2.2 K 1/2 W 10%	223-222
C68	CAPACITOR, DISC CERAMIC, 2200 PF	102-043	R34	RESISTOR, COMPOSITION, 1 K 2 W 10%	227-102
C69	CAPACITOR, DISC CERAMIC, .02 MF	102-056	R35	RESISTOR, COMPOSITION, 820 OHM 1/2 W 10%	223-821
C70	CAPACITOR, DISC CERAMIC, 2200 PF	102-043	R36	RESISTOR, COMPOSITION, 22 K 1/2 W 10%	223-223
C71	CAPACITOR, DISC CERAMIC, 2200 PF	102-043	R37	RESISTOR, COMPOSITION, 18K 1/2 W 10%	223-183
C72	CAPACITOR, BTP MICA 100 PF 2.5 KV	104-130	R38	RESISTOR, COMPOSITION, 120 OHM 1/2 W 10%	223-121
C73	CAPACITOR, VARIABLE, 4-16 PF	116-003	R39	RESISTOR, COMPOSITION, 4.7 K 2 W 10%	223-472
C74	CAPACITOR, VARIABLE, 100 PF	116-008	R40	RESISTOR, COMPOSITION, 15 K 2 W 10%	223-153
C75	CAPACITOR, DISC CERAMIC, .02 MF	102-056	R41	RESISTOR, COMPOSITION, 100 K 1/2 W 10%	223-104
C76	CAPACITOR, DISC CERAMIC, 2.2 PF NPO	100-113	R42	RESISTOR, COMPOSITION, 47 OHM 1/2 W 10%	223-470
C77	CAPACITOR, DISC CERAMIC, 1.1 PF NPO	100-102	R43	RESISTOR, COMPOSITION, 1 K 1/2 W 10%	223-102
C78	CAPACITOR, DISC CERAMIC, 2200 PF	102-043	R44	RESISTOR, COMPOSITION, 470 K 1/2 W 10%	223-474
C79	CAPACITOR, DISC CERAMIC, 12 PF NPO	100-113	R45	RESISTOR, COMPOSITION, 39 K 1/2 W 10%	223-393
C80	CAPACITOR, DISC CERAMIC, .005 MF	102-050	R46	RESISTOR, COMPOSITION, 39 K 1/2 W 10%	223-393
C81	CAPACITOR, DISC CERAMIC, .02 MF	102-056	R47	RESISTOR, COMPOSITION, 32 OHM 1/2 W 10%	223-323
C82	CAPACITOR, DISC CERAMIC, .02 MF	102-056	R48	RESISTOR, COMPOSITION, 22 K 1/2 W 10%	223-223
C83	NOT USED		R49	RESISTOR, COMPOSITION, 180 K 1/2 W 10%	223-184
C84	CAPACITOR, DISC CERAMIC, 470 PF NPO	102-032	R50	RESISTOR, COMPOSITION, 39 K 1/2 W 10%	223-393
C85	CAPACITOR, DISC CERAMIC, .005 MF	102-050	R51	RESISTOR, COMPOSITION, 18 K 1/2 W 10%	223-183
C86	CAPACITOR, MICA 2.5 KV, 470 PF	104-034	R52	RESISTOR, COMPOSITION, 2.2 K 1/2 W 10%	223-222
C87	CAPACITOR, DISC CERAMIC, 2200 PF	102-043	R53	RESISTOR, COMPOSITION, 22 K 1 W 10%	223-223
C88	NOT USED		R54	RESISTOR, COMPOSITION, 1 K 1/2 W 10%	223-102
C89	CAPACITOR, DISC CERAMIC, 2200 PF	102-043	R55	RESISTOR, COMPOSITION, 120 OHM 1/2 W 10%	223-121
C90	CAPACITOR, DISC CERAMIC, 2200 PF	102-043	R56	RESISTOR, COMPOSITION, 47 K 1/2 W 10%	223-473
C91	CAPACITOR, DISC CERAMIC, 2200 PF	102-043	R57	RESISTOR, COMPOSITION, 1 K 1/2 W 10%	223-102
C92	CAPACITOR, DISC CERAMIC, 2200 PF	102-043	R58	RESISTOR, COMPOSITION, 1.2 MEG 1/2 W 10%	223-125
C93	CAPACITOR, DISC CERAMIC, 2200 PF	102-043	R59	RESISTOR, COMPOSITION, 100 K 1/2 W 10%	223-104
C94	CAPACITOR, DISC CERAMIC, 2200 PF	102-043	R60	RESISTOR, COMPOSITION, 47 OHM 1/2 W 10%	223-470
C95	CAPACITOR, DISC CERAMIC, 2200 PF	102-043	R61	RESISTOR, COMPOSITION, 39 K 1/2 W 10%	223-393
C96	CAPACITOR, DISC CERAMIC, 2200 PF	102-043	R62	RESISTOR, COMPOSITION, 470 OHM 1 W 10%	223-471
C97	CAPACITOR, DISC CERAMIC, 15 PF NPO	100-114	R63	RESISTOR, COMPOSITION, 22 K 1/2 W 10%	223-223
C98	CAPACITOR, DISC CERAMIC, .02 MF	102-056	R64	RESISTOR, COMPOSITION, 470 OHM 1 W 10%	223-471
C99	NOT USED		R65	RESISTOR, COMPOSITION, 10 OHM 1 W 10%	223-100
C100	CAPACITOR, DISC CERAMIC, .005 MF	102-050	R66	RESISTOR, COMPOSITION, 27 K 1 W 10%	223-273
C101	CAPACITOR, DISC CERAMIC, .7 PF N-750	100-703	R67	RESISTOR, COMPOSITION, 56 K 1/2 W 10%	223-563
C102	CAPACITOR, DISC CERAMIC, 2200 PF	102-043	R68	RESISTOR, COMPOSITION, 330 K 1/2 W 10%	223-334
C103	CAPACITOR, DISC CERAMIC, .7 PF N-750	100-703	R69	RESISTOR, COMPOSITION, 1 MEG LINEAR VARIABLE	240-001
C104	CAPACITOR, DIPPED MICA 2.5 KV, 100 PF	104-130	R70	NOT USED	

PARTS LIST (Cont'd)

ITEM	DESCRIPTION	PART NUMBER	ITEM	DESCRIPTION	PART NUMBER
				<u>THOR 6, MODEL 417 AC POWER SUPPLY/MODULATOR</u>	
R70	RESISTOR, COMPOSITION, 5 K 5 W WIRE WOUND	232-004	C201	CAPACITOR, ELECTROLYTIC, 80/40 MF 375 V	108-100
R71	RESISTOR, COMPOSITION, 47 OHM 1/2 W 10%	223-470	C202	CAPACITOR, ELECTROLYTIC, 100 MF 450 V	107-010
R72	RESISTOR, COMPOSITION, 27 K 1 W 10%	225-273	C203	CAPACITOR, ELECTROLYTIC, 100 MF 450 V	107-010
R73	RESISTOR, COMPOSITION, 27 K 1 W 10%	225-273	C204	CAPACITOR, ELECTROLYTIC, 100 MF 450 V	107-010
R74	RESISTOR, COMPOSITION, 68 OHM 1 W 10%	225-680	C205	CAPACITOR, ELECTROLYTIC, 100 MF 450 V	107-010
R75	RESISTOR, COMPOSITION, 100 OHM 1 W 10%	225-101	C206	CAPACITOR, DISC CERAMIC, 470 PF	101-003
R76	RESISTOR, COMPOSITION, 47 OHM 1 W 10%	225-470	C207	CAPACITOR, DISC CERAMIC, 470 PF	101-003
R77	RESISTOR, COMPOSITION, 330 OHM 1/2 W 10%	223-331	C208	CAPACITOR, ELECTROLYTIC, 1 MF 450 V	107-002
R78	RESISTOR, COMPOSITION, 47 OHM 1 W 10%	225-470	C209	CAPACITOR, ELECTROLYTIC, 4 ME 500 V	107-004
R79	RESISTOR, COMPOSITION, 100 OHM 1 W 10%	225-101	C210	CAPACITOR, DISC CERAMIC, 01 MF	102-054
R80	RESISTOR, COMPOSITION, 100 K 1/2 W 10%	224-104	C211	CAPACITOR, DISC CERAMIC, 01 MF	102-054
R81	RESISTOR, COMPOSITION, 330 OHM 1/2 W 10%	223-331	C212	CAPACITOR, DISC CERAMIC, 01 MF	102-054
			C213	CAPACITOR, DISC CERAMIC, .005 MF	102-050
			C214	CAPACITOR, DISC CERAMIC, .005 MF	102-050
			C215	CAPACITOR, ELECTROLYTIC, 250 MF 25 V	107-011
			C216	CAPACITOR, DISC CERAMIC, 02 MF	102-056
			CR201	DIODE, SILICON, TYPE ED 3010 1000 V 500 MA	142-003
			CR202	DIODE, SILICON, TYPE ED 3010 1000 V 500 MA	142-003
			CR203	DIODE, SILICON, TYPE ED 3010 1000 V 500 MA	142-003
			CR204	DIODE, SILICON, TYPE ED 3010 1000 V 500 MA	142-003
			CR205	DIODE, GERMANIUM, TYPE 30015 500 V 500 MA	142-002
			F201	FUSE, 3 AMP 3 AC SLO-BLO	165-021
S1	SWITCH, 2 POLE, 3 POSITION, NS	286-002	K201	RELAY, 4 PDT	174-001
S2	SWITCH, 2 POLE, 2 POSITION	272-001	K202	RELAY, SPDT	171-001
S3	SWITCH, AC	Part of R28			
S4	SWITCH, 2 POLE, 5 POSITION, NS	272-002	L201	INDUCTOR, CL 10-328	180-007
			L202	INDUCTOR, CL 10-327	180-006
			L203	INDUCTOR, 879 K 2	180-005
			R201	RESISTOR, WIRE WOUND, 10 OHM 5 W	232-001
			R202	RESISTOR, WIRE WOUND, 10 OHM 5 W	232-001
			R203	RESISTOR, COMPOSITION, 68 K 2 W 10%	227-683
			R204	RESISTOR, COMPOSITION, 68 K 2 W 10%	227-683
			R205	RESISTOR, COMPOSITION, 68 K 2 W 10%	227-683
			R206	RESISTOR, COMPOSITION, 3.3 K 2 W 10%	227-332
			R207	RESISTOR, COMPOSITION, 10 K 2 W 10%	227-103
			R208	RESISTOR, COMPOSITION, 56 K 1/2 W 10%	223-563
			R209	RESISTOR, COMPOSITION, 220 K 1 W 10%	225-224
			R210	RESISTOR, COMPOSITION, 6.8 K 1/2 W 10%	223-682
			R211	RESISTOR, COMPOSITION, 560 K 1/2 W 10%	223-564
			R212	RESISTOR, COMPOSITION, 560 K 1/2 W 10%	223-564
			R213	RESISTOR, COMPOSITION, 2.7 MEG 1/2 W 10%	223-275
			R214	RESISTOR, COMPOSITION, 2.7 MEG 1/2 W 10%	223-275
			R215	RESISTOR, COMPOSITION, 680 K 1/2 W 10%	223-684
			R216	RESISTOR, COMPOSITION, 100 K 1/2 W 10%	223-104
			R217	RESISTOR, COMPOSITION, 680 OHM 1/2 W 10%	223-681
			R218	RESISTOR, COMPOSITION, 680 OHM 1/2 W 10%	223-681
			R219	RESISTOR, WIRE WOUND, 10 K 10 W	233-003
			R220	RESISTOR, WIRE WOUND, 30 K 20 W	235-002
			R221	RESISTOR, COMPOSITION, 27 K 2 W 10%	227-273
			R222	RESISTOR, COMPOSITION, 27 K 2 W 10%	227-273
			R223	RESISTOR, COMPOSITION, 220 K 1 W 10%	225-224
			R224	RESISTOR, COMPOSITION, 4.7 K 1/2 W 10%	223-472
			R225	RESISTOR, COMPOSITION, 10 1/2 W 10%	223-100
			R226	RESISTOR, COMPOSITION, 56 K 1 W 10%	225-563
			R227	RESISTOR, COMPOSITION, 56 K 1 W 10%	225-563
			S201	SWITCH, ROTARY	272-003
			T201	TRANSFORMER, AUDIO INTERSTAGE	607-003
			T202	TRANSFORMER, MODULATION	604-002
			T203	TRANSFORMER, POWER	603-005
			V201	ELECTRON TUBE, 12AX7	211-003
			V202	ELECTRON TUBE, 12BH7	211-006
			V203	ELECTRON TUBE, 6XQ6	216-026
			V204	ELECTRON TUBE, 6BQ6	216-026
X1	CRYSTAL, 10.700 MC	251-003			
X2	CRYSTAL, 10.705 MC	251-005			
X3	CRYSTAL, 11.156 MC	251-006			
X4	CRYSTAL, 10.698 MC	251-002			
X5	CRYSTAL, 10.701 MC	251-005			
T1	TRANSFORMER, 10.7 MC IF	602-002			
T2	TRANSFORMER, 10.7 MC IF	602-002			
T3	TRANSFORMER, 456 KC IF	602-001			
T4	TRANSFORMER, 456 KC IF	602-001			
T5	TRANSFORMER, 456 KC IF	602-001			
T6	TRANSFORMER, AUDIO OUTPUT	603-002			
V1	ELECTRON TUBE, TYPE 6CW4	216-020			
V2	ELECTRON TUBE, TYPE 6EH7	216-023			
V3	ELECTRON TUBE, TYPE 6AL5	216-012			
V4	ELECTRON TUBE, TYPE 6BU7	216-023			
V5	ELECTRON TUBE, TYPE 6BM6	216-013			
V6	ELECTRON TUBE, TYPE 6DJ8	216-021			
V7	ELECTRON TUBE, TYPE 6X3A	216-024			
V8	ELECTRON TUBE, TYPE 12BA7	211-004			
V9	ELECTRON TUBE, TYPE 6UJ5	216-021			
V10	ELECTRON TUBE, TYPE 7558	217-004			
V11	ELECTRON TUBE, TYPE 6883	216-028			
V12	ELECTRON TUBE, TYPE 12AX7	211-003			
V13	ELECTRON TUBE, TYPE 6A2	210-001			
V14	ELECTRON TUBE, TYPE 12AL5	211-001			

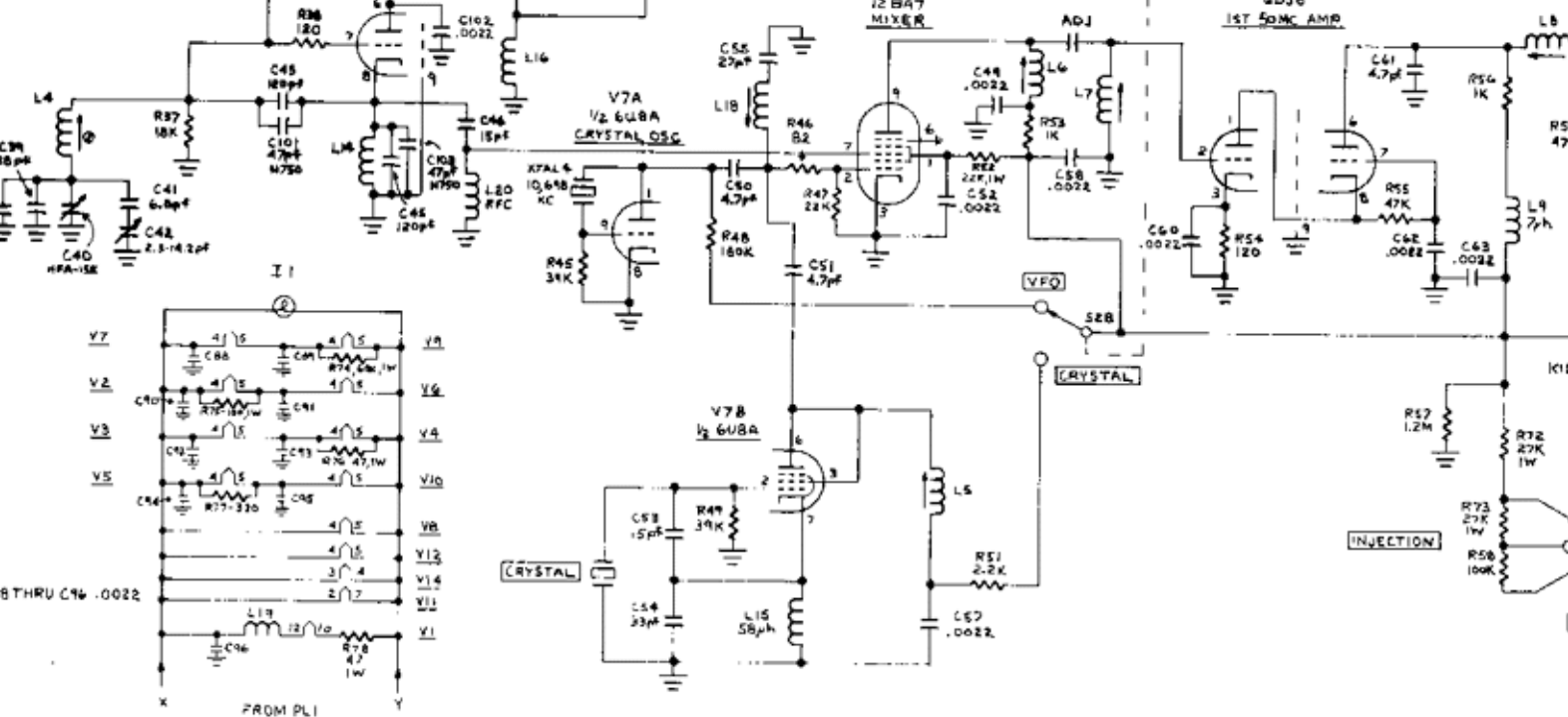
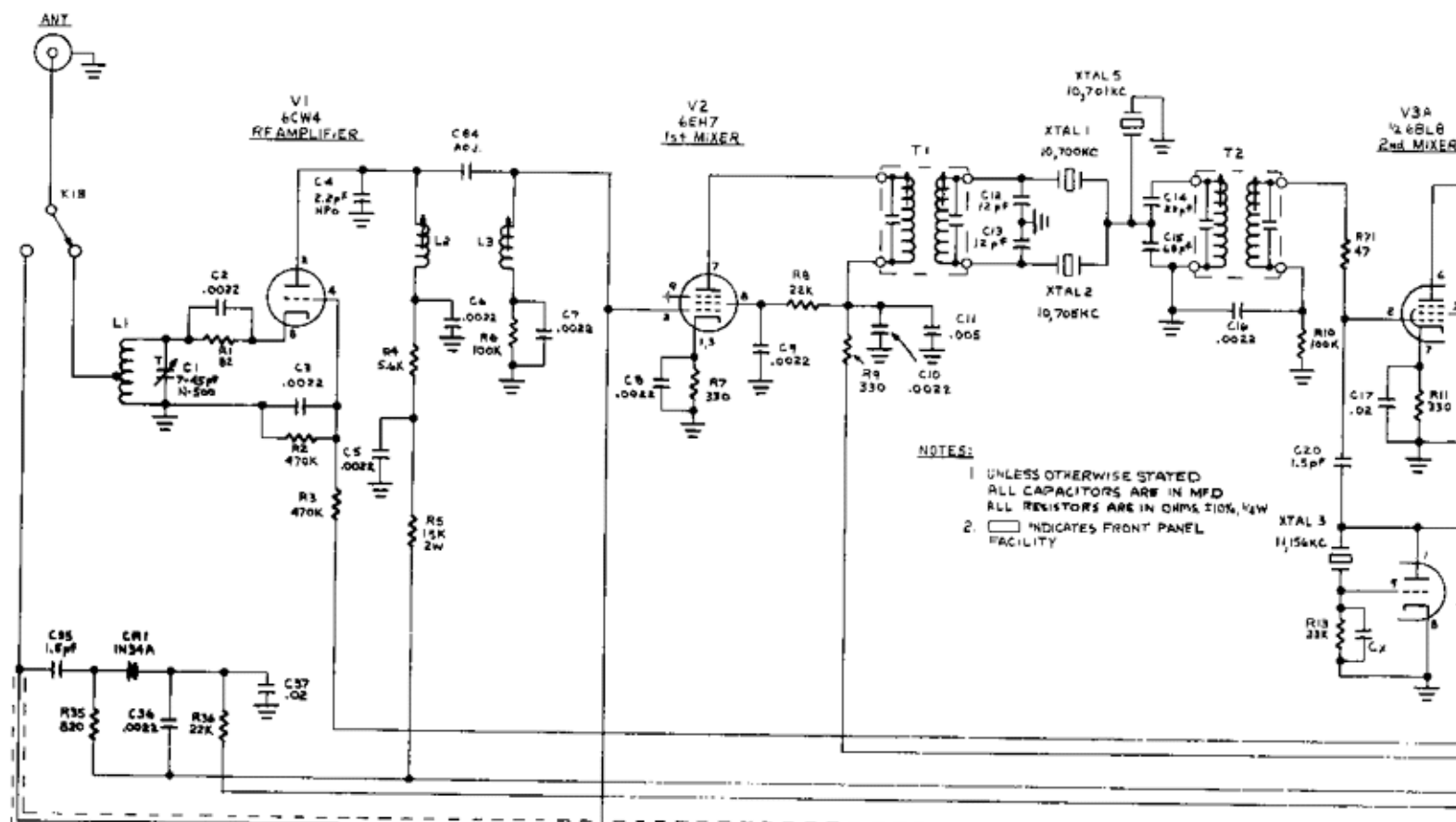

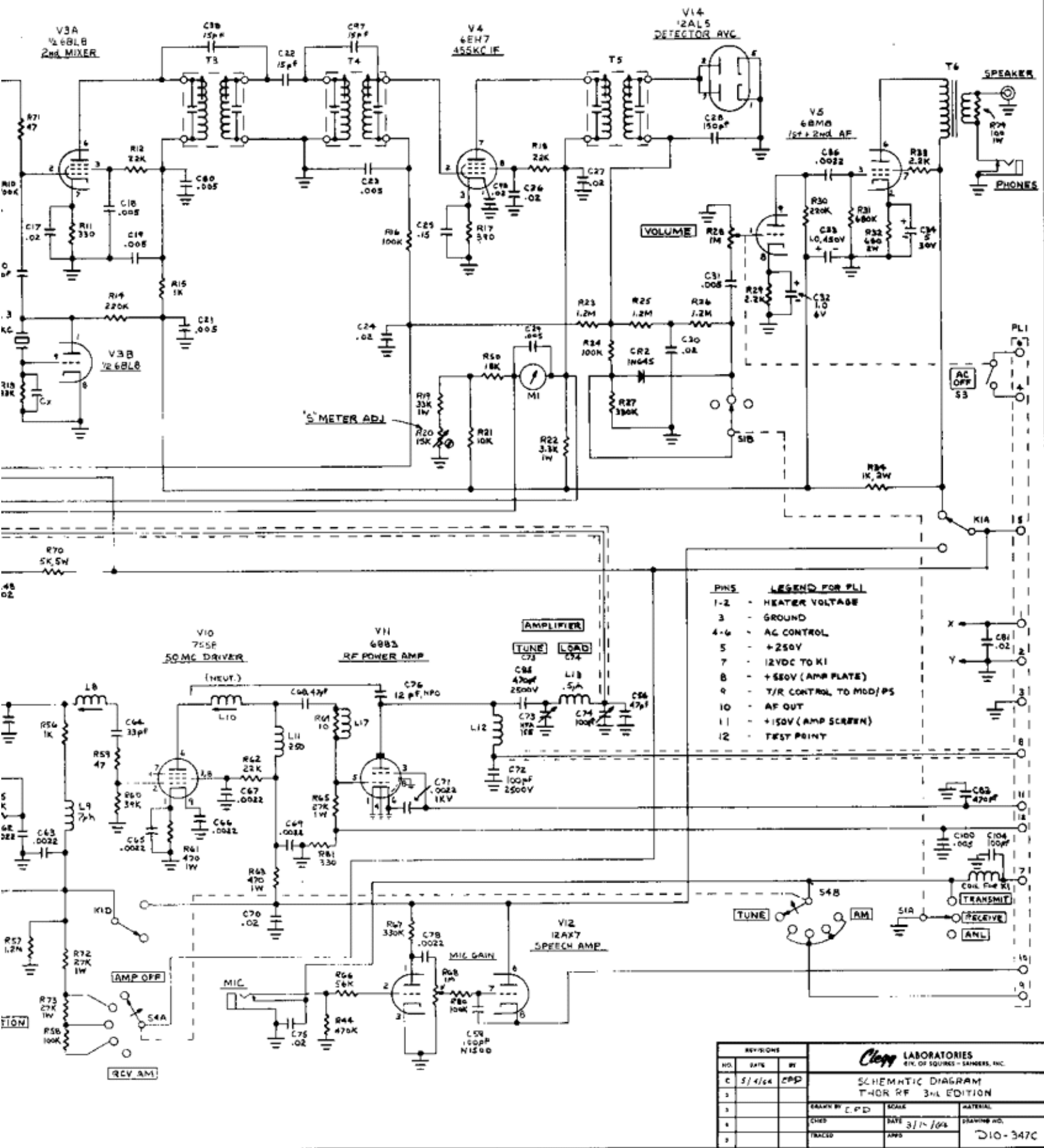

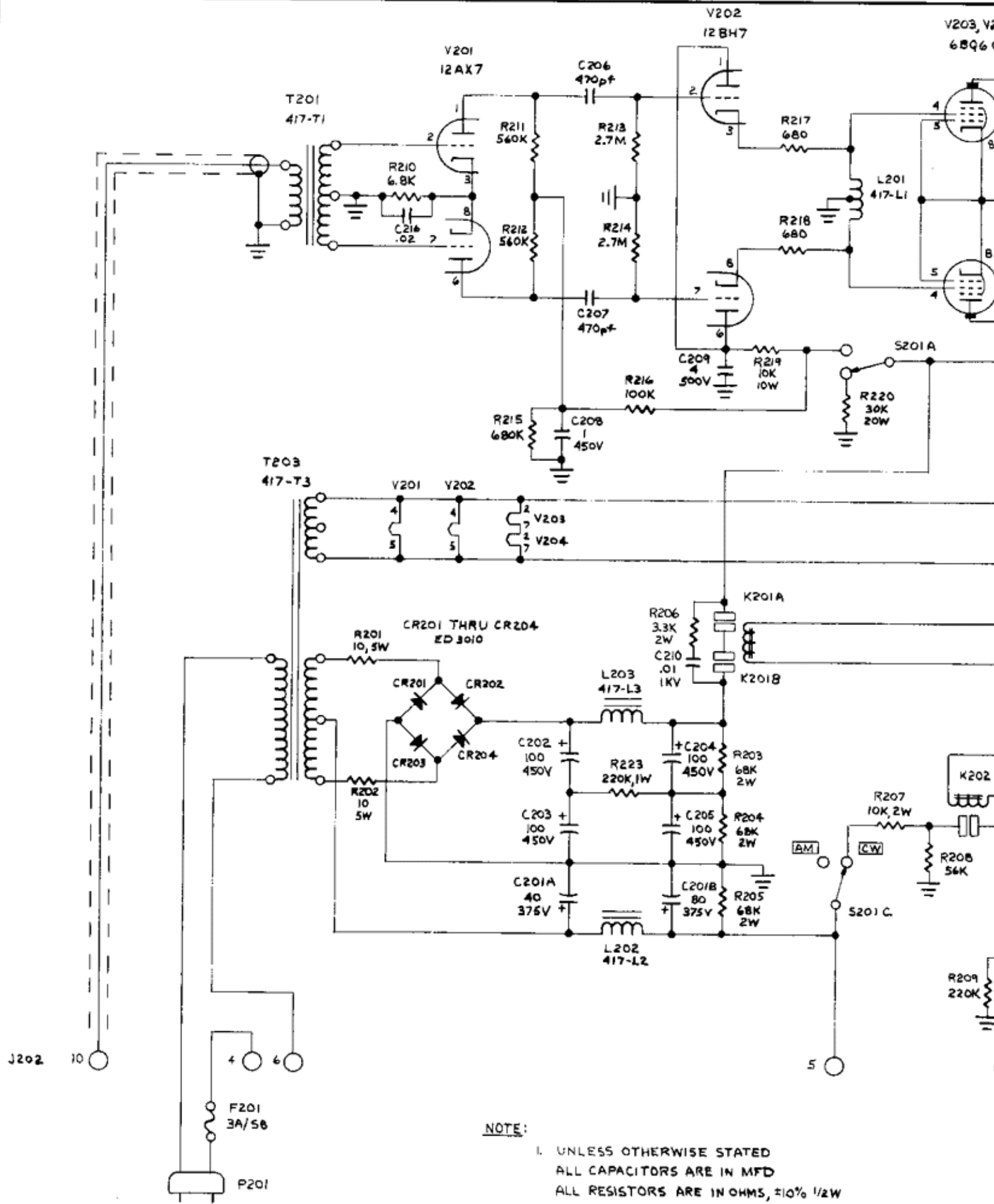

NOTE:

- 1. UNLESS OTHERWISE STATED
ALL CAPACITORS ARE IN MFD
ALL RESISTORS ARE IN OHMS, ±10% 1/2W

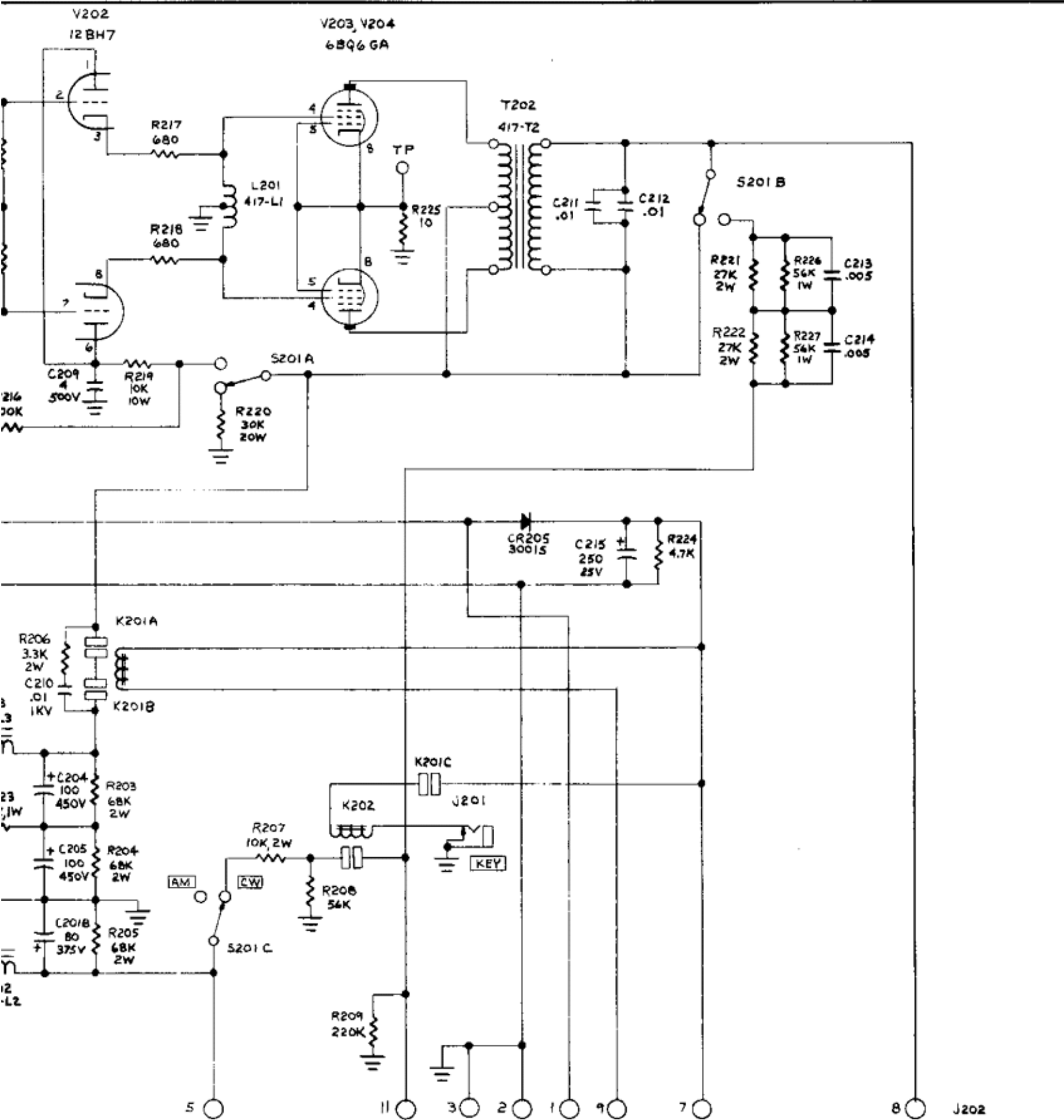

OTHERWISE STATED
 CAPACITORS ARE IN MFD
 RESISTORS ARE IN OHMS, ±10% 1/2W

REVISIONS			Clegg LABORATORIES DIV. OF SQUIRES - SANDERS, INC.		
NO.	DATE	BY	MODULATOR + PWR/SUPPLY - THK 2nd EDITION		
1	5/1/64	EPD	DRAWN BY	SCALE	MATERIAL
2			EPD		
3			CHKD	DATE	DRAWING NO.
4				3/19/64	
5			TRACED	APPD	C 10-3