

Vintage Product Review— The Collins 75A-4 Receiver

Stu Cohen, N1SC

Being asked to do a product review for the venerable Collins 75A-4 receiver is like asking a civil engineer to do an evaluation of the design of the Empire State Building; they both elicit the kind of response and respect normally reserved for benchmark milestones that rarely appear. A review of so lofty a standard can be a humbling experience, and, indeed, many consider the 75A-4 to be the best tube-type amateur-band receiver ever built.

It was, in fact, ahead of its time in many ways. Single sideband (SSB) was a relatively new communications mode in 1954, and the 'A-4 was the first receiver designed to make SSB easy to tune and a pleasure to operate, while not ignoring the AM, CW and RTTY modes. Although it was produced in relatively few numbers (less than 6000), the 75A-4 left its mark on amateur receiver design for years to come. Many manufacturers emulated its design. The Collins product was coveted then, and is still coveted by hams today. Unfortunately, its price tag (\$595 in 1955 dollars; later raised to \$695 in 1958), kept it out of the reach of all but the most affluent or dedicated of hams.

A Bit of History

The 75A-4 was the final iteration of a receiver design series started by the Collins Radio Company of Cedar Rapids, Iowa in 1947. Although the first 75A appeared that year (in prototype form), it wasn't until 1948 that the 75A-1 appeared on dealers' shelves. The series shared a unique design for its day: Crystal-controlled converters operating into a tracking IF amplifier and mixer and fed by a linear, low frequency, permeability-tuned variable oscillator (PTO). The architecture and PTO ensured equal stability and linear calibration on all bands and the tuned IF amplifier ensured optimum image response and gain across the mixer's output. The hermetically sealed linear PTO was not easy to manufacture, but it would remain a Collins trademark for years to come.

The 75A-1 receiver was quickly followed (in 1950) by the 75A-2. It boasted a new, redesigned dial with circuitry changes that took advantage of miniature tubes (these had

low interelectrode capacity and high transconductance, and performed measurably better at high frequencies than the earlier receiver's octal tubes). 1952 saw the introduction of the 75A-3—its claim to fame was the Collins mechanical filter—a marvel of electromechanical design that is still manufactured today (more about that later).

The 75A-4 finally appeared in 1955, and effectively “tied the ribbons” on the series. The receiver boasted, in addition to the standard 75A features, one 3.1 kHz mechanical filter, with an option for two more (switchable from the front panel), detectors for both AM and SSB/CW (including a new SSB product detector), a completely redesigned AGC circuit incorporating time constants specifically tailored to SSB and CW, improved circuit design exploiting the then current best miniature tubes available, a Q multiplier giving up to 40 dB of rejection at the IF and, finally, a novel new tuning technique called *passband tuning*. Later versions of the 'A-4 also incorporated a special 4:1 vernier tuning knob and gear mechanism that could be retrofitted to earlier models of the receiver. Interestingly, the RF amplifier had 17 dB less gain than earlier versions in order to cope with strong signal overload and bet-

ter adjust the receiver's dynamic range in the presence of strong signals.

What Makes It Work?

A block diagram of the receiver is shown in Figure 1. The 75A-4 is a dual conversion design on all bands except 160 meters, where it is single conversion—direct into the tunable IF. The first converter circuit (after the RF stage) employs a crystal-controlled oscillator (separate crystals for each band are selected by the main bandswitch) that, with the first mixer, converts the incoming RF signal to a variable IF of 1500 to 2500 kHz. This first IF is tracked, tuned and linked to the PTO (a Collins type 70E-24), through a complex system of gears, cams and powdered-iron slugs as shown in Figure 2. The first variable IF is mixed with the PTO output (1955 kHz to 2955 kHz) in a second mixer to produce a second, fixed-frequency IF of 455 kHz. Amazingly, all of the variably tuned stages, including the RF stage, the first mixer, the variable first IF system and the PTO, are all tuned by the main tuning dial, which is directly coupled to the PTO shaft. All coupling is accomplished through the previously discussed system of gears, cams, slugs and belts. In fact, with the cover removed from its IF section, the 75A-4 is a joy to watch as it is being tuned. One wonders how the designers got all this “Rube Goldberg” complexity to work properly, but they did.

The RF stage, a type 6DC6 pentode, was specially chosen for its low intermodulation distortion (IMD) characteristics. It was probably the best tube choice for its day, although better choices became available later on, and some later third-party modi-



Bottom Line

The Collins 75A-4 was considered by many the amateur receiver benchmark in 1954. It is not quite a contender based on today's toughest standards, but a joy to use none the less.

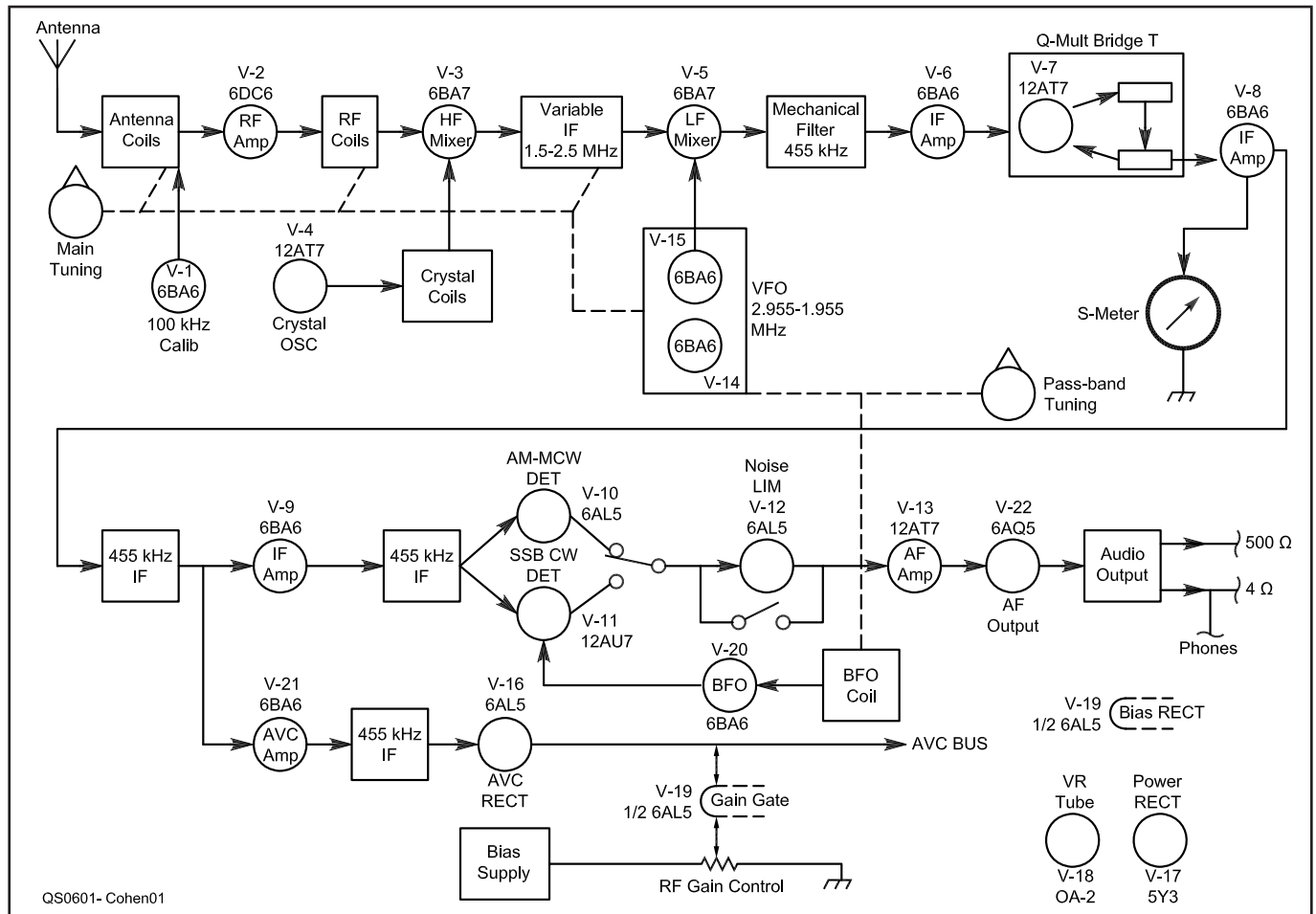

Figure 1—Block diagram of the Collins 75A-4 receiver. Note the tracked, variably tuned stages that are linked to the main tuning (PTO) dial. From QST, April 1955, page 41.

fications reflect that replacement choice. It is probably worthwhile to mention here that this 75A-4 receiver (S/N 1777) is completely “stock” and original; no circuit modifications have been made to it.

The second IF amplifier employs the famous Collins mechanical filter to shape its band-pass characteristic. This filter contains multiple nickel-alloy discs that are driven by *magnetostriction* in order to convert electrical current into mechanical vibration and back again. Without going into too much detail, suffice it to say that an input coil within the filter, resonant at the IF of 455 kHz, causes a close-coupled nickel wire to vibrate at this rate, synchronizing its mechanical motion to a series of discs contained within the filter. The last filter disc is “read” by another nickel wire coupled to an output coil, which translates the mechanical motion back into an output current.

What all of this fancy magnetostriction conversion does is to produce a selectivity curve with an almost ideal flat top (devoid of ripple) and almost straight sides. Crystal filters, by comparison, can produce as good a skirt response, but usually at the expense of ripple in their passband. Interestingly,

mechanical filters are still produced by Rockwell-Collins, and they find wide use in military receivers and avionics equipment. They are currently offered by at least one major amateur equipment manufacturer (Yaesu) as an option for some of their HF transceivers.

The 75A-4 receiver was normally outfitted with one 3.1 kHz mechanical filter. The receiver could accommodate two additional filters; these were left as options for their owners. This particular receiver has the stock Collins 3.1 kHz mechanical filter and, additionally, a 500 Hz CW filter and a 6 kHz AM filter. The additional filters were manufactured and supplied by Dave Curry, WD4PLI, and they function as well as the originals.¹

A Q multiplier follows, and it is used as a regenerative IF rejection filter, providing up to 40 dB of rejection for any heterodyne within the IF passband. Detectors consist of

a standard diode detector for AM followed by a noise limiter and include what is probably one of the first examples of a product detector to be found in a commercial amateur receiver. This SSB detector is actually a mixer, taking the BFO signal and mixing it with the output of the 455 kHz second IF amplifier. The result is a low distortion audio signal with linearity that improves greatly on the use of a diode detector for SSB. Ample and stable BFO injection levels coupled with superior frequency stability, the use of a well-designed product detector, attention to proper AGC time constants (both attack and delay times) and superior, low distortion audio result in the 75A-4’s excellence as an SSB receiver. Anyone who has ever tuned a 75A-4 across a SSB signal knows what I mean—it is simply a pleasure to copy SSB and CW on a 75A-4.

Earlier, I mentioned Collins’ introduction of a novel “new” tuning technique called “passband tuning.” In what was another first, the 75A-4 saw premier use of passband tuning in an amateur receiver. These days, we take passband tuning for granted; many modern HF transceivers offer it. In 1955, however, it was something very special. It’s probably

¹Curry uses currently manufactured Rockwell-Collins mechanical filters, packaging them in a case almost identical to the original 75A-4 design, with an impedance matching network. They are electrically equal to or better than the original Collins design. He can be contacted at Longwave Products, PO Box 1884, Burbank, CA 91507.

Table 1
Collins 75A-4, serial number 1777

<i>Manufacturer's Specifications</i>	<i>Measured in the ARRL Lab</i>
Frequency coverage: Receive, 1.5-2.5, 3.2-4.2, 6.8-7.8, 14-15, 20.8-21.8, 26.5-27.5, 28-30 MHz.	As specified.
Modes of operation: AM, SSB, CW.	As specified.
CW/SSB sensitivity (6 dB S/N, 3 kHz BW): 1.0 μ V.	Noise floor (mV), 500 Hz bandwidth: 3.5 MHz -140 dBm 14 MHz -141 dBm.
Blocking dynamic range: Not specified.	Blocking dynamic range, 500 Hz filter: <i>Spacing:</i> 50 kHz 20 kHz 5 kHz 3.5 MHz 116 dB 84 dB 74 dB ¹ 14 MHz 108 dB 90 dB 72 dB. ¹
Two-tone, third-order IMD dynamic range: Not specified.	Third-order IMD dynamic range: <i>Spacing:</i> 50 kHz 20 kHz 5 kHz 3.5 MHz 93 dB 73 dB 59 dB ¹ 14 MHz 79 dB 74 dB 62 dB. ¹
Third-order intercept: Not specified.	Third-order intercept: <i>Spacing:</i> 50 kHz 20 kHz 5 kHz 3.5 MHz +1 dBm -23 dBm -35 dBm 14 MHz -17 dBm -24 dBm -27 dBm.
Second-order intercept point: Not specified.	+64 dBm.
Audio output: 0.75 W at 10% THD into 4 Ω .	1.7 W at 10% THD into 4 Ω .
IF/audio response: Not specified.	Range at -6 dB points (bandwidth): CW: 240-819 Hz (579 Hz) USB: 500-3044 Hz (2544 Hz) LSB: 544-2925 Hz (2381 Hz) AM: 111-2993 Hz (2882 Hz).
Power requirements: 105-125 V ac, 85 W.	
Size (HWD): 10.5x17.3x15.5 inches; weight, 35 pounds.	
Third-order intercept points were determined using an S5 reference.	
¹ Filter blow-by was observed on these measurements.	

an understatement to say that the ability to move the IF passband with respect to a signal in that passband is a valuable attribute.

The extremely stable BFO is adjusted by a front panel control labeled PASSBAND TUNING. That control shaft is directly coupled to the PTO mount (which is in a gim-

baled crib) by a flexible metal belt, such that the PTO drive shaft doesn't move (the dial frequency remains fixed, held by the friction of the dial drag adjustment); only the PTO mount moves. As the BFO frequency is shifted (through a range of about ± 2000 Hz, centered around 455 kHz), the PTO frequency

is altered by the same amount. The result is that the fixed IF passband is shifted with respect to the signal and the signal can thus be shifted across the IF passband. A little test will reveal that the 75A-4's PTO-BFO coupling is extremely precise. The receiver's 100 kHz calibrate signal is set to zero beat with the BFO signal. The PASSBAND TUNING control is then moved through its range. On a properly adjusted 75A-4, the BFO will remain in perfect zero beat as the PASSBAND TUNING control is moved from one end to the other! The coupling between BFO and PTO is so good that the BFO appears to be phase locked to the calibrate signal. This is an amazing achievement. It is a testament to the receiver's designers that they were able to do this mechanically, rather than electrically, and thus avoid the non-linear phase issues that could be associated with an electrical solution. A view of the PTO-BFO coupling mechanism can be seen in Figure 3.

The 75A-4 operator thus has a commanding arsenal of interference fighting aids at his or her side. There are three switchable mechanical filters with very steep skirts and almost textbook-like passband characteristics, a very effective passband tuning control to dump an interfering signal off the passband edge and, finally, a Q multiplier to reject heterodynes in the IF passband by up to 40 dB. In addition, a very effective noise limiter, which works in all modes, is also available by a front panel switch.

Dial calibration is another area in which the 'A-4 excels. A switchable 100 kHz crystal calibrator is included to calibrate the PTO. After calibration, the linear PTO can be read to a marked accuracy of 1 kHz and interpolated to less than half that figure. The edge-to-edge linearity of the PTO is better than the dial index width and, in any case, within 150 Hz. Remember, we're back in 1955

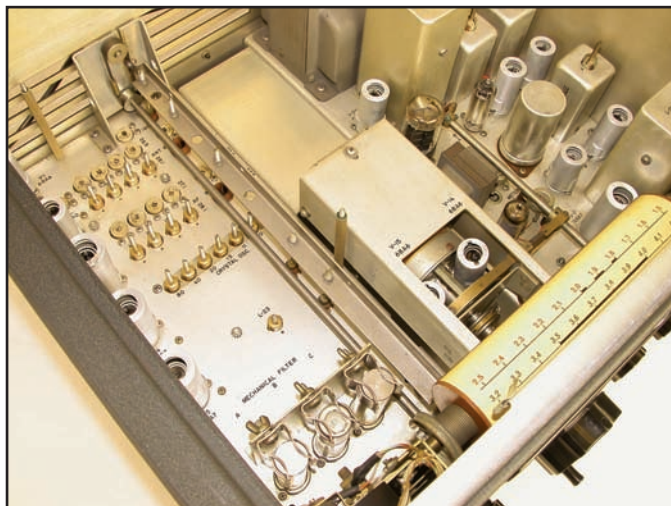

Figure 2—Inside view of the 75A-4 with the cover over the slug rack removed. The bar on the left side of the receiver moves the slugs in the RF and first IF up and down as the PTO is tuned.

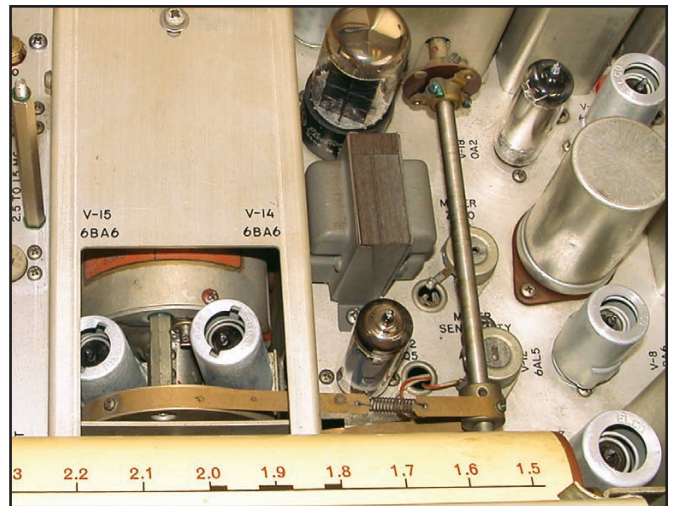

Figure 3—Close-up of the BFO-PTO coupling mechanism with the PTO shifted to full USB position. This forms the basis for the passband tuning system.

here—and this is an *analog* dial. Electronic frequency counters were not in wide use (other than in laboratories) and direct dial readout to 500 Hz was almost unheard of then. Lucky indeed was the operator who could maintain a sked on 14,133 kHz, put the receiver dial on 14,133, turn the receiver on, and have the other op be there. Of course, unless the other op was using similar Collins equipment, the chances are that he wouldn't be exactly there! A close-up of the 75A-4's analog dial is shown in Figure 4.

Operation

Although the size of this radio is certainly not commensurate with today's equipment, it's not ungainly for a 22-tube receiver. Collins recognized that size and weight were becoming an issue with "modern" hams and the 75A-4's cabinet was made noticeably smaller than its earlier brothers in the series. The earlier 75As were designed to be easily rack-mountable, so their panels and cabinets were designed to accommodate standard size 19 inch rack. The 75A-4 cabinet, however, was designed as a part of the front panel; it is noticeably more svelte than earlier models. Indeed, the 75A-4 weighs 15 pounds less than a 75A-3 and Collins managed to shave almost 4 inches off the width of the receiver and 2 inches off the height, compared to its ancestors. Interesting, though, is that the 75A-4 is 2¼ inches deeper than its earlier siblings.

Regardless of its size, it's obvious during operation that this is a "real" radio—the controls are large and easy to read—there are no menus, miniature switches or tiny knobs here. Obvious, too, is the fact that vacuum tubes take a while for their filaments and cathodes to heat—we're easily jaded by *instant-on* communications equipment these days. A good minute passes after ac power is applied before any sounds are heard from this receiver's speaker.

Tuning this receiver is different than tuning a modern radio. The analog tuning knob is connected directly to the PTO—there's no flywheel on a digital shaft encoder here. The tuning is silky, yet it lacks the inertia that a weighted knob would impart. If you've never tuned a Collins amateur receiver, it takes some getting used to. I like the tuning feel—it's directly in touch with the circuit elements that determine frequency in the receiver—a "close to the road" feeling, if you will. There is a dial drag adjustment; this sets the torque level that must be imparted to the tuning knob to get it to move. Properly adjusted, the analog dial has no backlash and is a pleasure to operate. All 75A-4s, save the earliest batch, came with a 4:1 vernier gear reduction tuning knob resulting in a 25 kHz per revolution tuning rate. This is



Figure 4—View of the Collins 75A-4 analog dial. Note that readout can be accomplished to the nearest 1 kHz—14,133 kHz in this example, a formidable achievement for 1955!

a noticeable improvement over the earlier direct-drive knob, and it makes tuning side-band and CW a real delight. The 4:1 knob also has a crank that makes those journeys to the band edges to nab the elusive DX much easier and faster.

The lab MDS measurements reveal that this is a very sensitive receiver, with a noise floor of -140 dBm or about 0.02 µV. The "close-in" numbers, however, suggest that the receiver is not up to present-day standards regarding blocking and IMD. That's not surprising, as the tuned first IF stage has relatively low Q and the tracking was designed mainly to counter images and level the output, not produce a superior roofing filter. Nevertheless, performance under all but extremely crowded band conditions is still excellent and a 75A-4 will hold its own against almost any receiver. Under less crowded band conditions, the performance is superb.

Many agree that signal readability is key to the 75A-4's ability to recover signals that are near the noise floor and the combination of the 'A-4's superb mechanical filters and a very linear signal chain results in signal readability that must be experienced to be believed. In a side-by-side comparison I could copy signals better on the 75A-4 than on an all-solid-state HF transceiver 35 years its junior. The signals were *present* on the transceiver, but they weren't as *readable*. Perhaps this is due to the superior linear phase characteristics through the receiver's signal processing chain. The signal readability is definitely better on this classic.

The 75A-4 really shines on a quiet band. Here, the signal to noise ratio is outstanding, and on 20 meter CW I find myself preferring the 'A-4 to every other receiver I have, including the receiver section of my current production medium priced transceiver. The best way to describe this is to say that the signal copy is less fatiguing on the 75A-4 than on the other receivers. Signals seem to rise out of the noise more cleanly, and tuning

the 'A-4 is simply more relaxed. I well realize that this evidence is more anecdotal than scientific, but the static measurements simply do not reveal what is going on with this receiver in a dynamic sense. To paraphrase an old saying: "The proof of the receiving is in the tuning!"

Part of the superb signal handling capability of the 'A-4, I believe, can be attributable to the receiver's gain structure, its clean oscillators and its AGC system. The AGC time constants are very well chosen for both SSB and CW (attack time is 10 ms; release time is 100 ms in fast, 1 s in slow) and I found that I never had to "ride gain" with the RF GAIN control when surfing the SSB and CW sub-bands. This is in direct contrast to a 75A-2 receiver I have. There, the AGC system is unable to cope with large signal excursions and manual control of RF gain is always required on CW and SSB. I'm sure that the detector also plays a role. The product detector in the 75A-4 is simply superb on both CW and SSB; the recovered audio is clean and distortion-free, and while the 'A-4 does an excellent job on AM, this receiver was really born to be used on SSB and CW. I do some occasional AM work and I find that reinsertion of the AM carrier and treatment of an AM signal as an SSB signal eliminates a good deal of the selective fading often associated with weak AM signals. The 75A-4 makes that easy to do with its 3.1 kHz mechanical filter—I find that bandwidth to be just about perfect for synchronous AM detection.

If you've concluded from all of this that I like the Collins 75A-4, you're correct. It's quite amazing to be able to compare a 50 year-old receiver to its modern counterparts, and have a favorable result, but there you have it. It's easy to see why this is a coveted receiver—then and now. The 75A-4 was relatively expensive in 1955, but I think it was worth every penny of its price, and if you ever have a chance to use one, do so—I think you'll be pleasantly surprised.

Stu Cohen, N1SC, an ARRL Technical Advisor, was the Technical Editor of QST from 2002 until semi-retirement to eastern Washington in 2005. He has been an engineering consultant, an assistant chief engineer, and a chief engineer at several commercial and public television stations. Stu was an Engineering Supervisor at ABC-TV, Los Angeles from 1974 through 1993 and received an Emmy from the National Academy of Television Arts and Sciences. First licensed in 1954 (at age 12) as K2IOG, he loves vintage radio and television and has a library devoted to early wireless. Stu chases DX on HF CW and occasionally operates AM on 75 meters. He has a Bachelor of Engineering degree in Electrical Engineering from New York University-College of Engineering and can be reached at n1sc@arrl.net.

QST