

70K-2 PTO Annotated Schematics

(w/ Alignment Notes and Lead Color Codes)

Frequency Range: Minimum: 2.5 to 2.7 MHz
 Typical Stop to Stop: 2.5 MHz – (2 to 10 kHz)
 to 2.7 MHz +(2 to 10 kHz) ~ Symmetrical

70K-2 OSC (Circa 1969)

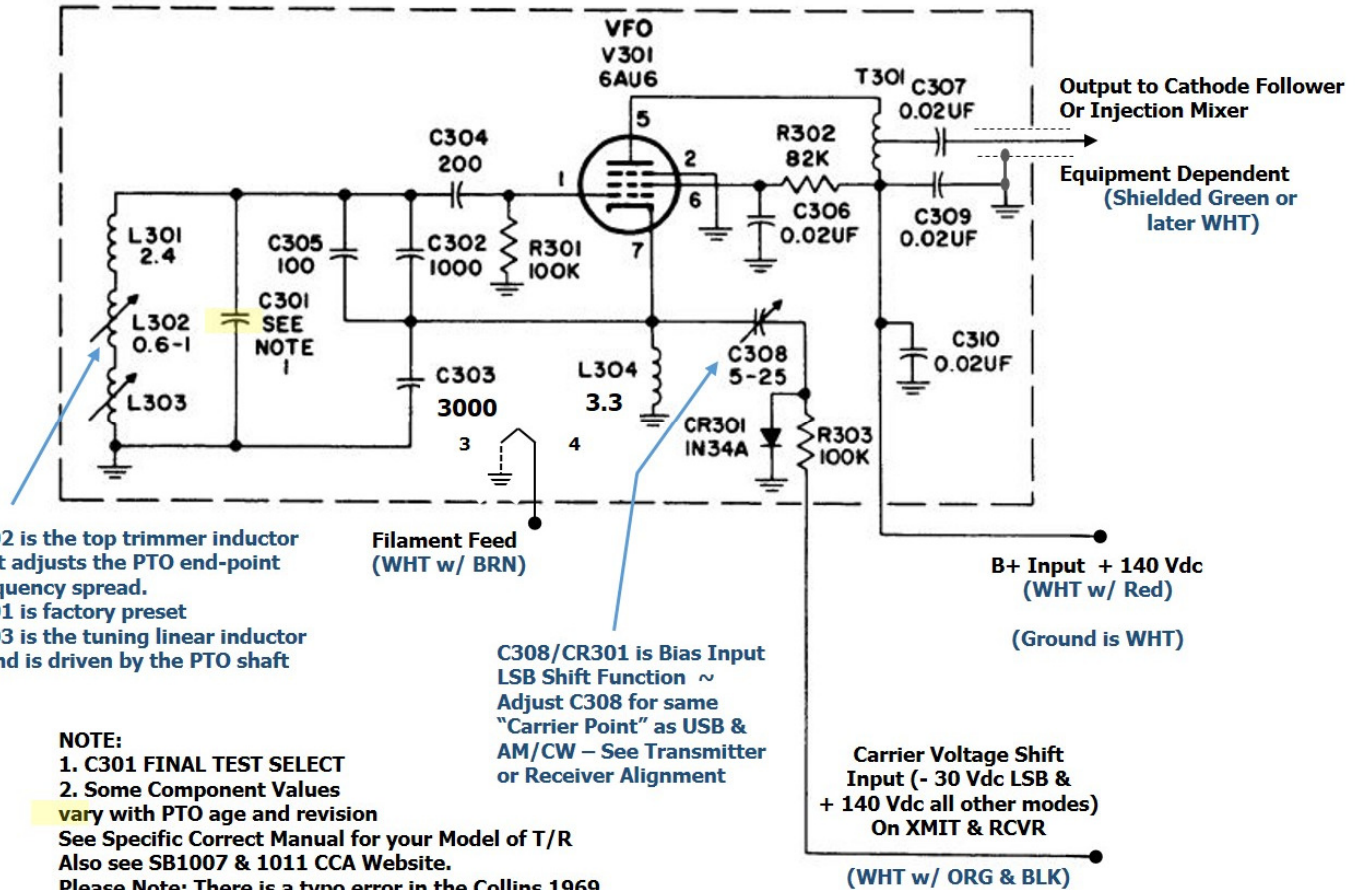

Prepared by Bill Carns, N7OTQ/K0CXX
 As edited by Don Jackson, W5QN !
 December 2015

Comments or Corrections to wcarns@austin.rr.com
 Or call 512 618-2762

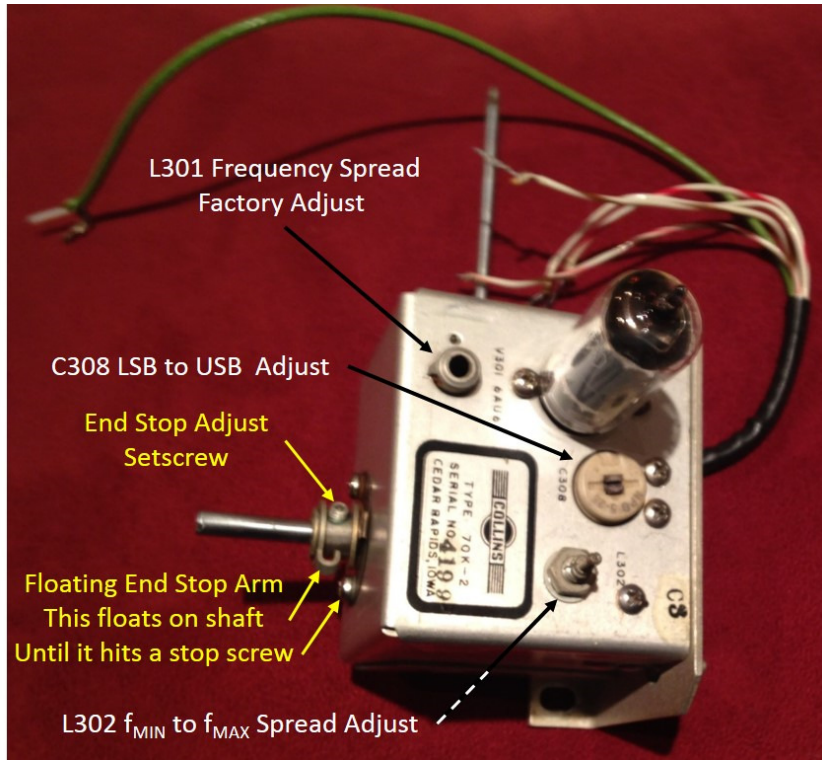

70K-2 Annotated Schematic (later) ~ See below

