

ADVANCED COMMUNICATIONS

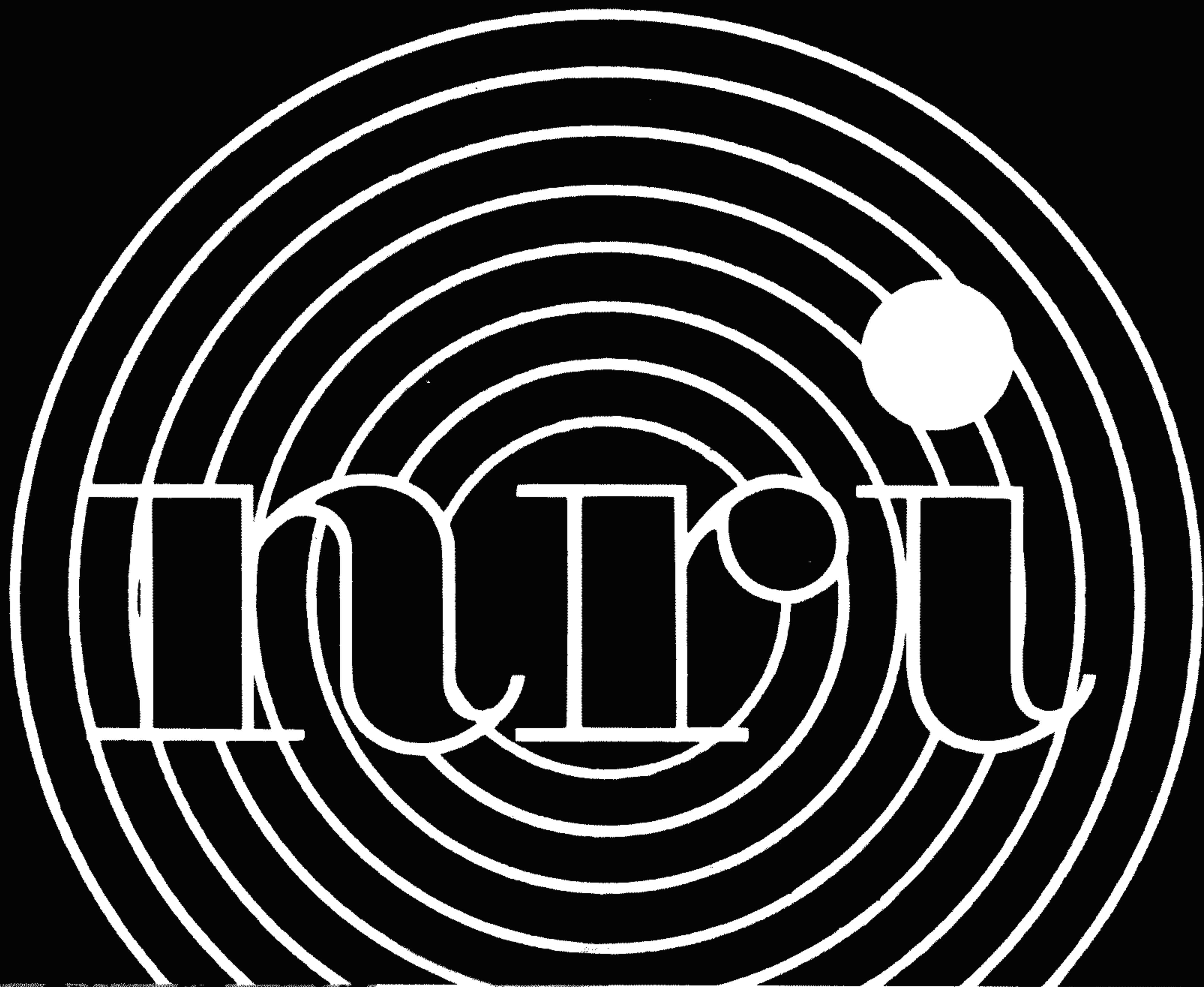

**ADJUSTMENT
AND MAINTENANCE
OF THE MODEL 452
SYNTHESIZED 2-METER
TRANSCEIVER**

ADVANCED COMMUNICATIONS

**ADJUSTMENT AND
MAINTENANCE OF THE MODEL 452
SYNTHESIZED 2-METER
TRANSCEIVER**

Advancing the thrust
of McGraw-Hill
in technical training



TABLE OF CONTENTS

1. Introduction	Page 1
2. Alignment	Page 2
3. Corrective Maintenance	Page 4
4. Component Replacement Data	Page 8
5. Index of Figures:	
Internal Adjustments in the Model 452	Page *
Circuit Board Interconnection Diagram	Page *
Programmable Divider Circuit Board	Pages 11, 12, and 13
VCO/Audio Circuit Board	Pages 14, 15, and 16
Oscillator Circuit Board	Pages 17, 18, and 19
Receiver Circuit Board	Pages *, 20, and 21
RF/Power Supply Circuit Board	Pages 22 and 23
Display Assembly	Pages *, 24, and 25
Power Amplifier	Page 26
Harmonic Filter	Page 27

* Located on a center sheet

ADJUSTMENT AND MAINTENANCE OF THE MODEL 452 SYNTHESIZED 2-METER TRANSCEIVER

This manual contains information which will enable you to maintain your Model 452 Synthesized Transceiver in top operating condition. It is divided into two sections, the first of which lists the various set-up and alignment adjustments and gives the procedure for correctly setting them. The second section is devoted to corrective maintenance. Here, information is given to assist you in finding and correcting any problems in your completed transceiver which may occur after it has been operating for some time.

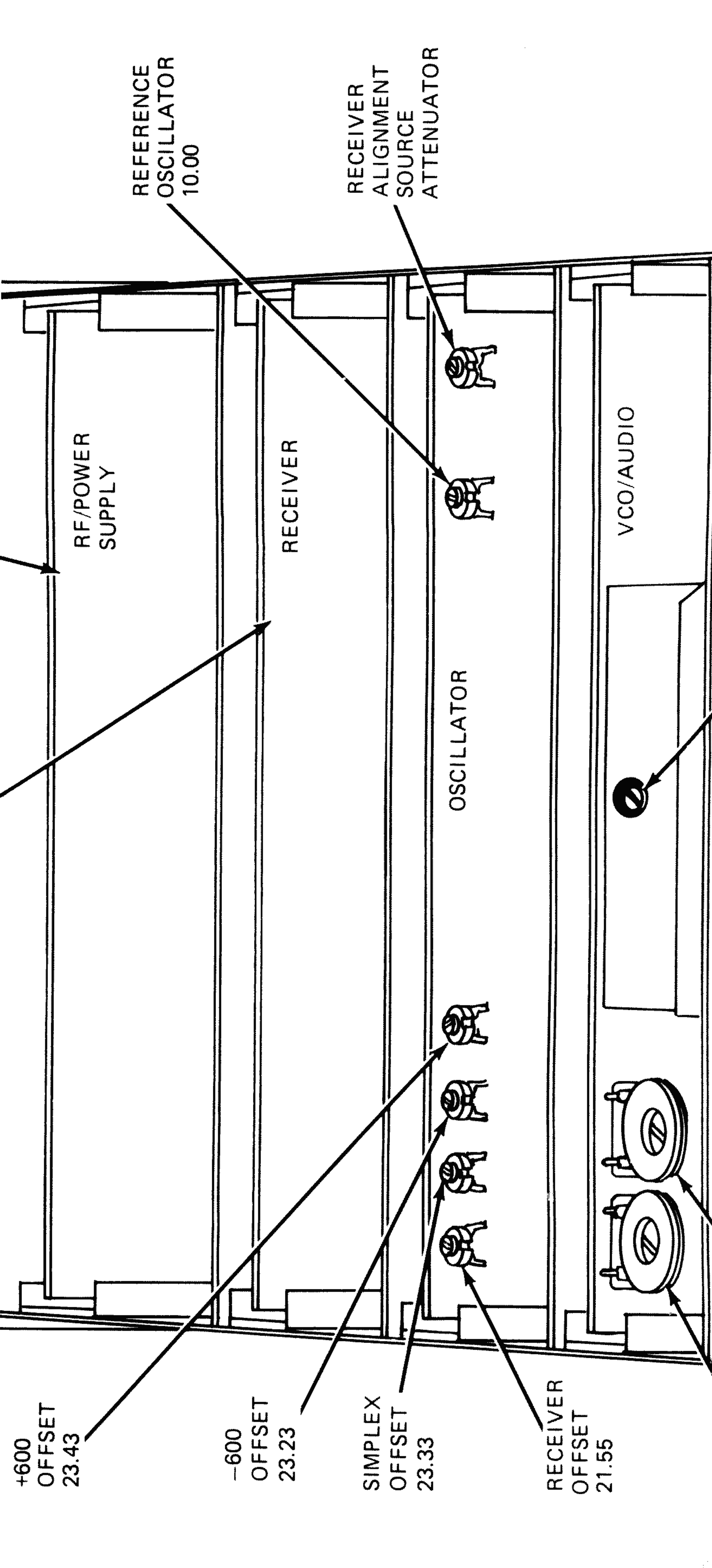
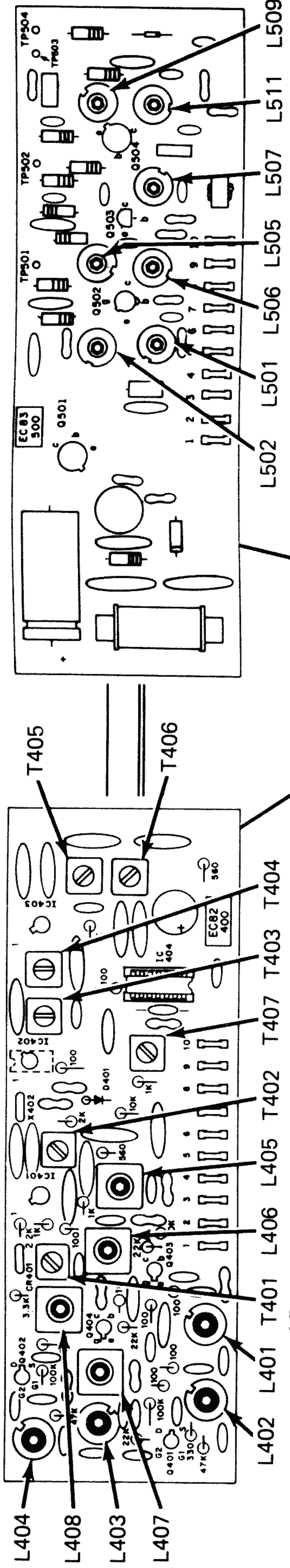

L404
L408
L403
L407

L402 L401 T401 L406 L405 T402 T407 T403 T404

L502 L501 L506 L505 L507 L511 L509

+600
OFFSET
23.43

-600
OFFSET
23.23

SIMPLEX
OFFSET
23.33

RECEIVER
OFFSET
21.55

RF/POWER
SUPPLY

RECEIVER

OSCILLATOR

VCO/AUDIO

REFERENCE
OSCILLATOR
10.00

RECEIVER
ALIGNMENT
SOURCE
ATTENUATOR

OFFSET
23.43

-600
OFFSET
23.23

SIMPLEX
OFFSET
23.33

RECEIVER
OFFSET
21.55

MIKE
GAIN

DEVIATION

REFERENCE
OSCILLATOR
10.00

RECEIVER
ALIGNMENT
SOURCE
ATTENUATOR

RECEIVER

OSCILLATOR

VCO/AUDIO

PROGRAMMABLE
DIVIDER

VCO
TRIMMER

VCO
COIL

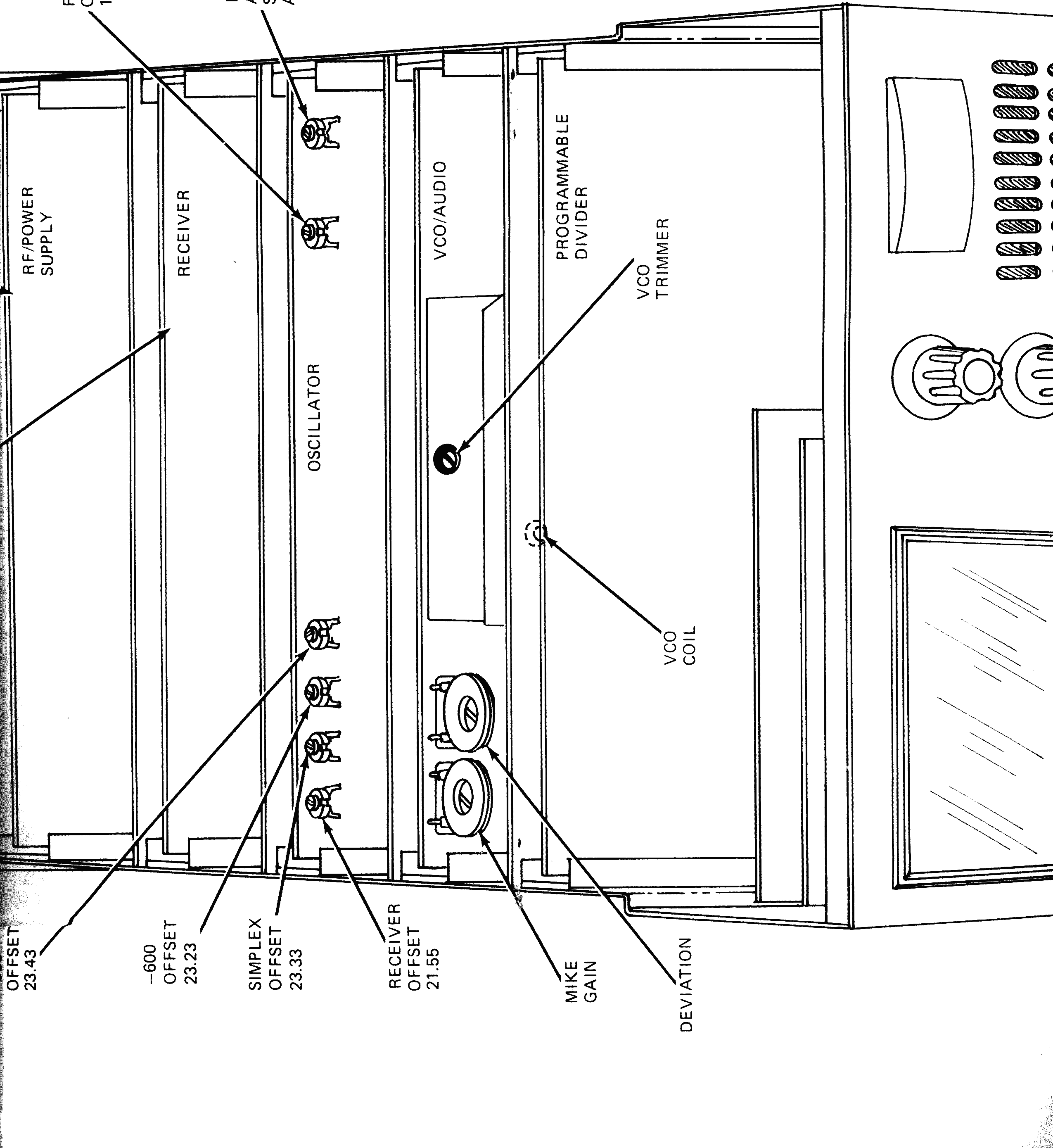

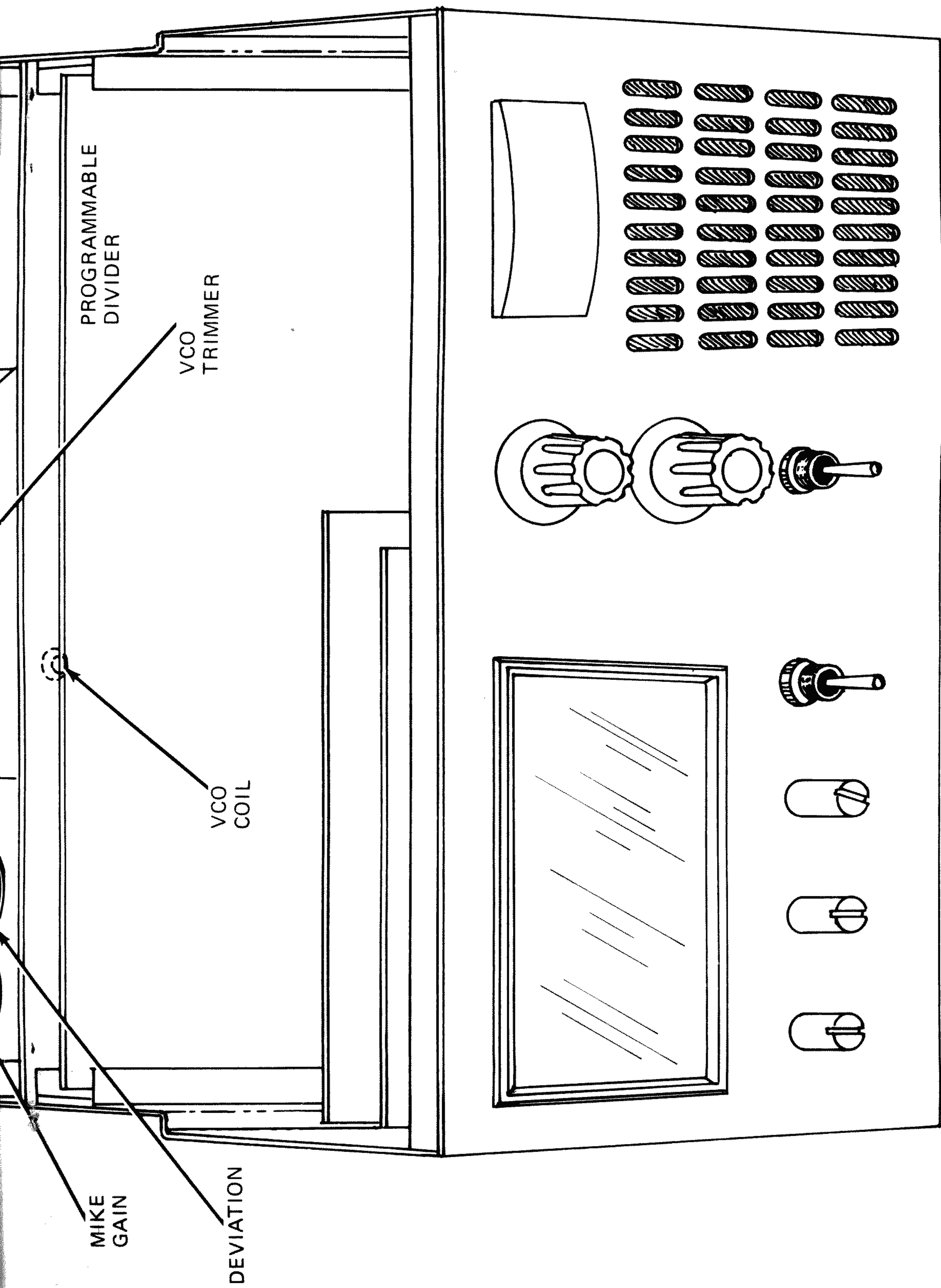

Fig. 1. Internal adjustments in the Model 452.

Alignment

Alignment is the process of adjusting the circuits in your transceiver to operate satisfactorily at its designed operating frequencies. When properly adjusted, your transceiver will perform at its best. The complete alignment procedure is presented in this section. It should be performed exactly as explained to achieve optimum performance from your Model 452 Transceiver.

To perform the complete alignment you will need the following items:

- (1) Frequency counter (CONAR Model 202 or better)
- (2) Extender circuit board (EC87)
- (3) 3" length of shielded cable
- (4) Two clip leads and 2 single alligator clips
- (5) Alignment tools (AT3 and AT4)
- (6) TVOM or vtvm
- (7) Resistor-lamp dummy load

Before aligning your Model 452 Transceiver, remove any antenna you may have connected and install the dummy load. All steps of the alignment should be performed with the power switch in the LOW position. Figure 1 shows the location of the internal adjustments in the Model 452.

THE MASTER REFERENCE OSCILLATOR

If you have a frequency counter which can read above 10 MHz, connect it to TP DIR on the oscillator (300) circuit board. If you are using the CONAR Model 202 Frequency Counter, connect it to TP $\div 5$. Then, adjust the 10.00 trimmer capacitor for a frequency of exactly 10.000 MHz at TP DIR, or 2.000 MHz at TP $\div 5$. If you are familiar with any error in your frequency counter, compensate for this error when making the adjustment.

THE OFFSET OSCILLATOR

If your frequency counter can measure frequencies of 25 MHz or higher, connect it to TP OSC OUT. If there is insufficient signal amplitude at this point, use an alligator clip to short the two terminals which are labeled A together, and the second alligator clip to short together the two terminals labeled B. Then, monitor the frequency at TP DIR. This is a TTL signal, and it should be able to drive your frequency counter directly.

If your frequency counter is the CONAR Model 202 or a similar instrument which cannot reach the 25 MHz range, install the two alligator clips as just described, and connect your frequency counter to TP $\div 10$.

Since the transceiver is now set to receive signals, the offset oscillator should be producing a frequency of 21.55 MHz,

which will give a frequency of 2.155 MHz at TP $\div 10$. Adjust the 21.55 trimmer capacitor, if necessary, to obtain an output of exactly this frequency. As with the master reference oscillator, if you are familiar with any error in your frequency counter, compensate for it when making this adjustment.

Set the Transmit Mode switch to SIM and key the transmitter. If you have the alligator clips in place, the relay will not operate, but the offset oscillator will switch to Transmit Mode. Adjust the 23.33 trimmer capacitor for a frequency of exactly 23.333 MHz (or 2.333 MHz at TP $\div 10$).

Keep the transmitter keyed and move the Mode switch to the -600 position. Adjust the 23.23 trimmer capacitor for a frequency of exactly 23.233 MHz (2.323 MHz at TP $\div 10$).

Now move the Mode switch to the +600 position and adjust the 23.43 trimmer capacitor for a frequency of exactly 23.433 MHz (2.343 MHz at TP $\div 10$). As with the earlier adjustments, remember to compensate for any known error in your frequency counter when adjusting these trimmer capacitors.

Unkey the transmitter, and remove the alligator clips from the A and B terminals, if you installed them earlier.

THE VOLTAGE-CONTROLLED OSCILLATOR

Set the frequency selector switches to the center of the desired 2 MHz operating frequency segment. Normally this segment will be from 146 to 148 MHz, so you should set your switches to 147.00 MHz. If you prefer to operate over a different segment, set the switches to the center of that segment. Set the Transmit Mode switch to SIM. Extend the VCO/audio circuit board (200) and set up a voltmeter to monitor the positive dc voltage at pin 207.

Key the transmitter and use your AT3 alignment tool to adjust the VCO coil for a reading of 2.2 volts at pin 207. Unkey the transmitter and use your AT4 alignment tool to adjust the VCO trimmer capacitor for a reading of 2.2 volts at pin 207.

Remove the extender board and install the VCO/audio circuit board in its slot.

THE RF MULTIPLIER/DRIVER STAGES

Extend the rf/power supply circuit board. Check to be sure that the front panel switches are still set to the center frequency of your desired operating segment. Connect your voltmeter to measure the positive dc voltage at TP501. A 3 to 5 volt range will be satisfactory.

Key the transmitter, and adjust the two white coils (L501 and L502) for maximum voltage at TP501. Go back and forth between the two coils several times to make sure that you do in fact have maximum voltage at this terminal.

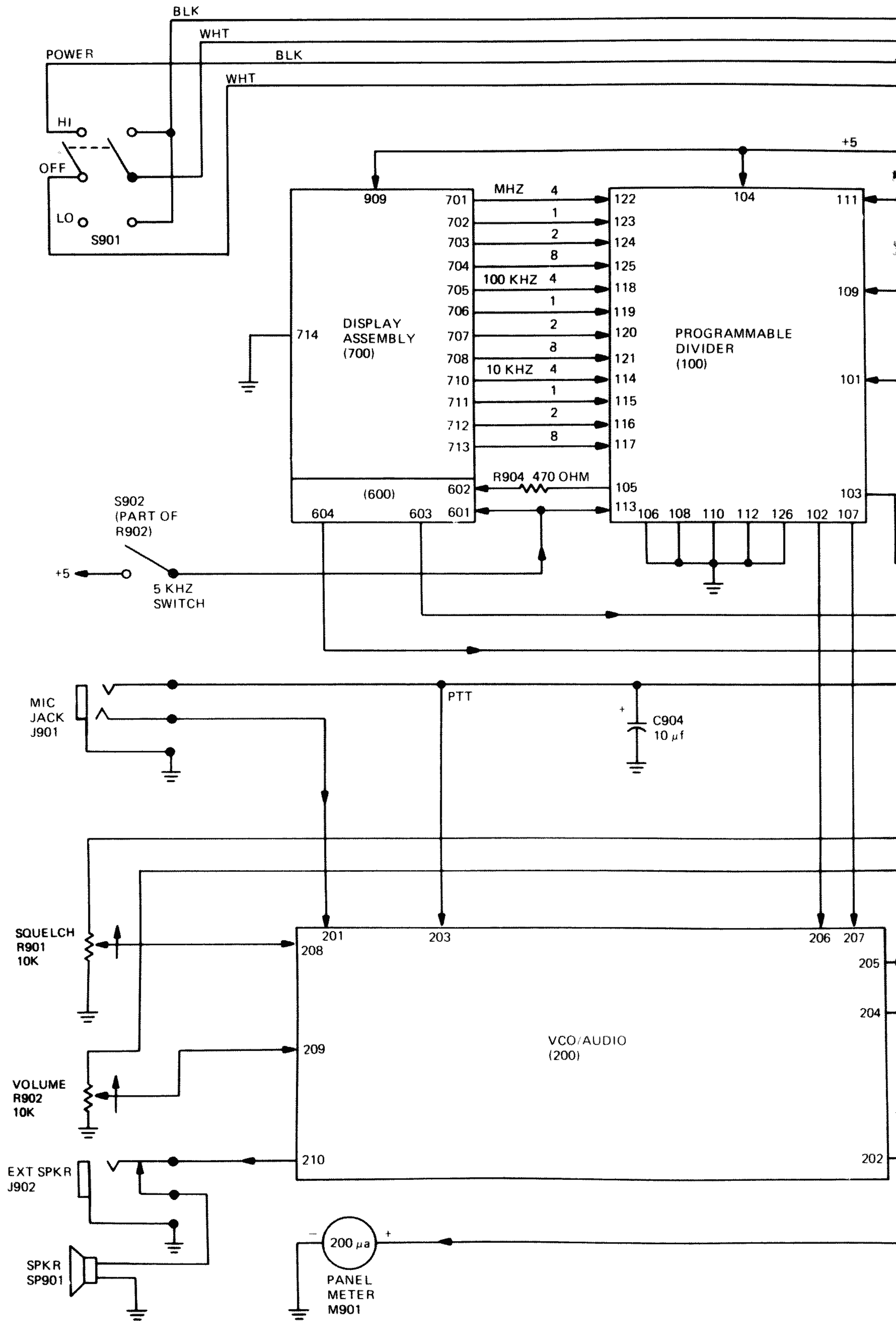

Fig. 2. The Model 452 circuit

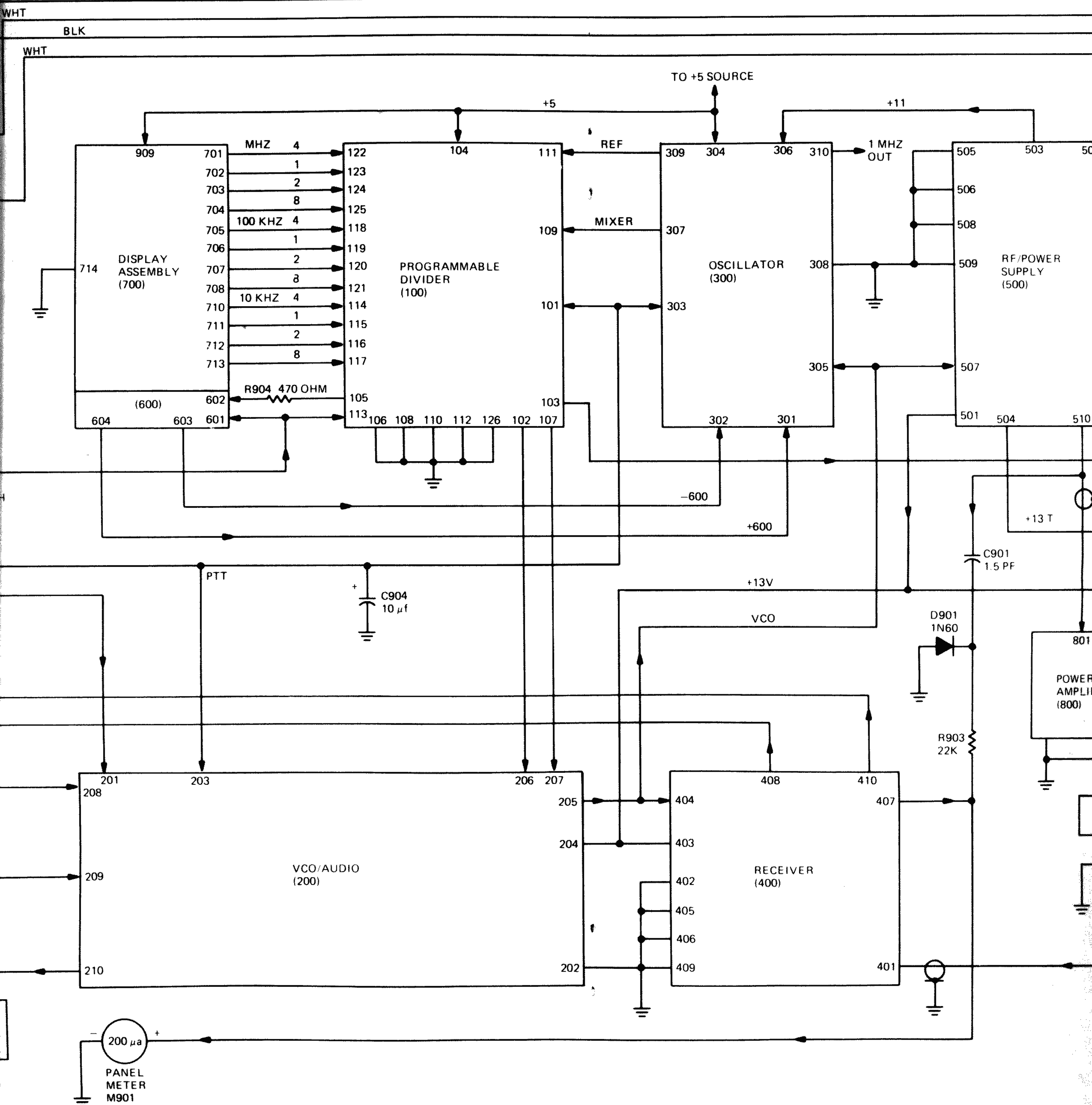
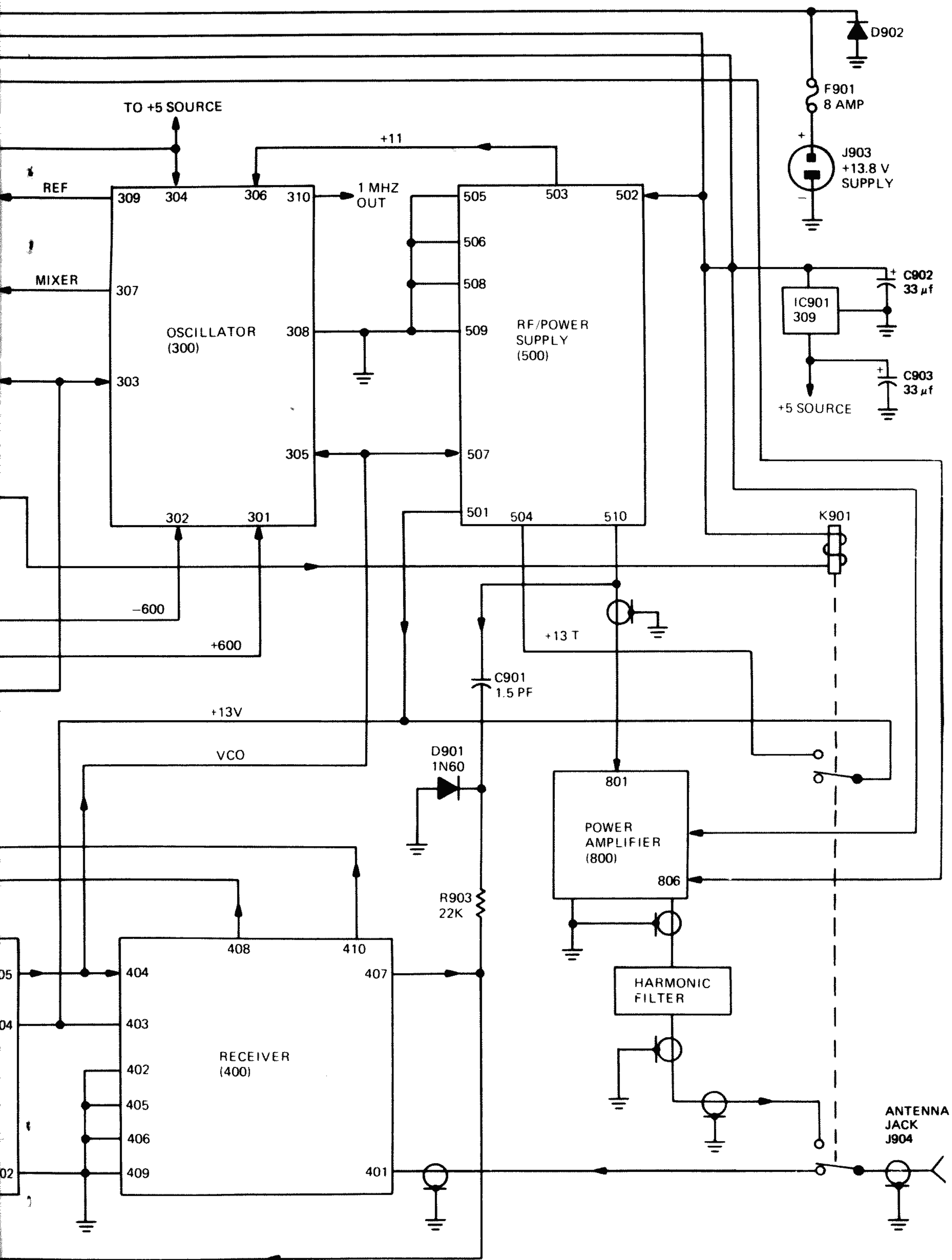

Fig. 2. The Model 452 circuit board interconnection diagram.



Circuit board interconnection diagram.

Move your voltmeter probe to TP502, and adjust the two red coils (L505 and L506) for maximum voltage. As before, rock both coils back and forth slightly to be sure that you do, in fact, have maximum voltage at TP502.

Move your voltmeter probe to TP503 and adjust the single yellow coil (L507), directly above the toroidal transformer, for a maximum voltage reading. Observe the light given off by the dummy load lamp (do *not* look directly at the lamp) and adjust the remaining yellow and blue coils (L509 and L511) for maximum brilliance.

Go back and repeat these adjustments two or three times to compensate for interaction between them, and make sure that you do, in fact, have a maximum at each test point as you proceed with this part of the alignment. Then, unkey the transmitter, remove the extender board, and install the rf/power supply circuit board in its slot.

THE RECEIVER

Remove the microphone and the dummy load from the transceiver chassis and set them aside. Turn the transceiver upside down, and connect a 3" length of shielded cable between pins 310 and 401. Connect the ground braid to pin 402.

Turn the transceiver upright, and extend the receiver circuit board. Be sure your switches are set to the center of the 2 MHz segment where you wish to operate. Check for an indication on the panel meter.

If you obtain no deflection on the panel meter, connect a clip lead from TP ÷ 10 on the oscillator circuit board to pin 401. Again, check for deflection on the panel meter. If you now have deflection, adjust the VCO multiplier coils (large shield cans) and then the rf coils (plastic forms) for maximum deflection. When the meter begins to read close to half-scale, remove the clip lead. You should now have sufficient meter indication to continue with the alignment.

If you still obtain no meter reading even with the clip lead in position, preset the coils and transformers as follows:

- (1) 4 rf coils seven turns CW from the top of the coil form.
- (2) VCO multiplier coils five turns CW from the top of the coil form.
- (3) All i-f transformers (small shielded cans) one turn CCW from bottom of free rotation.
- (4) T407, immediately above pins 409 and 410, one turn down from top of the free rotation.

Turn the power off, and turn the chassis on its edge. Carefully remove the demodulator assembly connected to the terminal strip between the 400 and 500 boards, on the bottom of the chassis. Be careful not to clip any leads or damage components, as this assembly will be restored to this location once the receiver has been aligned. Connect the mounting foot of the demodulator probe to the chassis with a clip lead. Then, connect your voltmeter to monitor the positive dc voltage on the free end of the resistor lead, and hook the free capacitor lead over the exposed lead of the 100k-ohm resistor immediately below Q402 on the circuit board. Restore power, check to be sure that the front panel controls are still set to a

frequency of 147.00 MHz, and adjust the four VCO multiplier coils for maximum dc voltage.

Turn off the tvom, remove the demodulator probe, and put it aside. Check to be sure that the clip lead from pin 401 to TP ÷ 10 is still in place. Then, adjust T402 for a maximum front panel meter reading.

Continue to adjust the remaining i-f transformer cans in sequence for maximum reading. Then, adjust the four rf coils. Once the meter approaches a half-scale reading, remove the clip lead and continue with the alignment.

When you have some meter deflection with the clip lead removed, start again by adjusting the four rf coils for maximum deflection. Proceed to adjust the four VCO multiplier coils (large shielded cans) for maximum meter deflection.

Finally, starting from the top left corner of the board and proceeding in a CW direction, adjust the i-f transformers (small shielded cans) for maximum meter deflection. Repeat all adjustments two or three times, to compensate for interaction between different coils.

For final alignment of the receiver, remove the shielded cable between pins 310 and 401 and connect an antenna to the antenna jack on your transceiver. Tune to a local repeater or other on-the-air signal and adjust the quadrature detector coil (small shielded can above pins 409 and 410) for maximum volume with minimum distortion. Then, using the front panel meter as an indicator, readjust the VCO multiplier coils and all i-f transformers for maximum deflection.

Turn off all power, remove the extender board, and install the receiver board in its slot. Then, reinstall the detector circuit in its original location. Connect the capacitor lead to pin 510 and the resistor lead to pin 407. This will enable the front panel meter to perform as a transmit indicator as well.

THE TRANSMIT AUDIO CIRCUIT

Preset the GAIN control on the VCO/audio (200) board 90 degrees CCW from its CW stop. Preset the DEV control to 90 degrees CW from its CCW stop. If you do not have instruments with which to set microphone gain and deviation, these presets will prove satisfactory for normal use. However, if you can borrow such instruments later, they will enable you to make more accurate settings.

If you have an oscilloscope, connect it to monitor the waveform at TP AUD. Connect the dummy load to the antenna jack, and make sure that your transceiver is set to LOW power. Then, key the transmitter and speak normally into the microphone. Adjust the GAIN control so that the peaks of your voice waveform are just being clipped. This will give maximum microphone gain without noticeable distortion.

If you have a deviation meter, connect it to your transceiver, and adjust the DEV control for deviation of 5 kHz or slightly less, while whistling at a steady rate into the microphone. This will enable your transceiver to operate normally with both individual stations and repeaters, without exceeding the pass-band of the other station's receiver.

This completes the alignment of your Model 452 Synthesized Transceiver.

Corrective Maintenance

The information in this section is designed to help you quickly locate the source of any defects which occur in your Model 452 Transceiver. When you have a problem with your completed unit, the first thing that you should do is determine exactly what the symptoms are. Operate all of the front panel controls and carefully observe and listen for any abnormal indications which may be present.

Table 1 is a troubleshooting chart which lists many of the abnormal symptoms you might encounter. The chart directs your attention to the circuit area most likely to be causing the trouble and suggests some of the components most likely to be at fault.

Figure 2 is a circuit board interconnection diagram of your

transceiver. Using an oscilloscope, a tvom, and this block diagram, you should be able to quickly localize to a certain stage the source of your problem.

To localize the trouble further, you will have to use the schematic diagram of the board where you suspect the problem is, and the voltage chart for that board. A schematic of each board, a voltage chart for each board, and component location information for each board are included in this section.

The components on each board are identified by the circuit symbol used on the overall schematic diagram of that board. These figures will help you to physically locate components which you decide to test or inspect.

TABLE 1
TROUBLESHOOTING CHART
GENERAL

Problem	Probable Cause	Remedy
Unit will not turn on. Frequency display remains dark	a. Power supply turned off	Turn on supply
	b. Power cord not plugged in	Plug in cord
	c. Fuse blown	Replace fuse
Frequency display will not present normal digits in one or more positions. Strange characters or incorrect digit sequences are produced	a. Open or shorted solder connections in lines between frequency selector switches and 7447 decoder/driver IC's	Resolder any cold joints Locate and remove any solder shorts or splashes
+11 volt supply inoperative. All others okay	a. Q501 damaged	Replace Q501
	b. Short on +11 volt line	Locate and remove short
+5 volt supply inoperative. All others okay	a. Short on +5 volt line	Locate and remove short
	b. IC901 damaged	Replace IC901

RECEIVER SECTION

Problem	Probable Cause	Remedy
Synthesizer will not lock	a. Frequency selector switches set out of range	Set switches to a frequency in the 146.000 to 148.000 MHz range
	b. VCO tuning coil or receiver offset trimmer misaligned	Retune coil and trimmer. Control voltage at pin 207 should be 2.2 volts for both transmit and receive when the controls are set to 147.000 MHz, SIM
	c. Q202 shorted	Replace
	d. Q203 open	Replace
	e. Q204 or Q205 defective	Replace
	f. D202 defective	Replace
Squelch control has no effect. Volume control normal	a. Squelch control miswired	Recheck wiring
	b. IC203 damaged	Replace
	c. IC404 damaged	Replace
No audio. No indication on S meter	a. Receiver coils and transformers misaligned	Retune receiver board
	b. IC401, IC402, or IC403 damaged	Trace signal to locate IC with no output. Replace damaged IC
	c. Volume control miswired	Recheck wiring
No audio. S meter indicates normally. Squelch control has no effect	a. IC404 damaged	Replace
	b. IC203 damaged	Replace
	c. IC204 damaged	Replace
Audio distorted	a. T407 misaligned	Retune
Audio too loud. Volume control has little or no effect	a. Volume control miswired	Recheck wiring

(continued on next page)

TROUBLESHOOTING CHART

TRANSMITTER SECTION

Problem	Probable Cause	Remedy
Relay does not pull in when microphone button is pressed	a. Microphone or plug miswired	Correct wiring
	b. Q103 or Q104 shorted	Replace
	c. Q105 open	Replace
	d. Frequency selector switches set outside lock range	Reset switches to a frequency in the 146.000 to 148.000 MHz range
Relay remains energized at all times	a. Q105 shorted	Replace
	b. D104 shorted or reversed	Replace or correct
Relay pulls in when transmitter is keyed, but quickly drops out again	a. Synthesizer unlocks when transmitter is keyed. Offset oscillator not switching properly	Check solder joints on IC301 and related circuits
	b. Receiver VCO trimmer capacitor remaining in circuit	Check for shorted Q203 or open Q202
Relay pulls in, but panel meter gives no indication. No output at TP501	a. Power not reaching multiplier and driver stages	Check for dirty, bent, or miswired relay contacts and cold solder joints on rf power supply board
	b. L501, L502 misaligned	Retune coils
	c. Q502 damaged	Replace
No output at TP502. TP501 okay	a. L505 and L506 misaligned	Retune coils
	b. Q503 damaged	Replace
	c. Q502 not powered	Check solder joints
No output at TP503. TP501 and TP502 okay	a. L507 misaligned	Retune
	b. Q503 not powered	Check solder joints
	c. Q504 damaged	Replace
No output at TP504. TP501, TP502, and TP503 okay	a. L509, L511 misaligned	Retune
	b. Q504 not powered	Check solder joints
	c. D502 damaged	Replace

TRANSMITTER SECTION (Cont'd)

Problem	Probable Cause	Remedy
No indication on panel meter. TP501, TP502, TP503, and TP504 okay	a. D902 damaged or installed backwards	Replace or reverse
Panel meter gives indication but dummy load remains dark	a. Lamp in dummy load burned out	Replace
	b. Dirty or miswired relay contacts	Clean contacts and check wiring
	c. Open cable between driver output and power amplifier module	Check all cables
	d. Shorted or open output cable	Check all cables
Output power okay but no modulation	a. Microphone or plug miswired	Correct wiring
	b. Q201 shorted	Replace
	c. D201 open or shorted	Replace
	d. GAIN or DEV controls improperly set	Adjust controls for proper modulation level
Audio will not squelch during transmit	a. IC203 damaged	Replace

Component Replacement Data

This section provides part numbers for obtaining replacement diodes, transistors, and integrated circuits should you need them. In the left column is the circuit symbol. This is the symbol that identifies the component on the schematic. The number in the middle column is the NRI in-house part number. If you write to us providing this number and the

proper maintenance, a replacement part can be mailed to you. The number in the right column is the part number of a suitable replacement part. For many parts you may find more than one replacement number. In that case they are all suitable replacements. These numbers should be used when you want to obtain a replacement from an electronic parts house.

COMPONENT REPLACEMENT DATA

PROGRAMMABLE DIVIDER (EC79)

Circuit Symbol	Part Number	Replace With
Q101	TS43	2N4124, SK3124, ECG108
Q102	TS43	2N4124, SK3124, ECG108
Q103	TS43	2N4124, SK3124, ECG108
Q104	TS43	2N4124, SK3124, ECG108
Q105	TS39	2N3053, SK3024, ECG128, RS276-2030
IC101	IG5	7400
IC102	IG76	MC4044, 11C44C
IC103	IG8	7473, DM7473
IC104	IG77	MC4016
IC105	IG77	MC4016
IC106	IG77	MC4016
D101	CR23	1N914, SK3100, ECG177, RS276-1144
D102	CR23	1N914, SK3100, ECG177, RS276-1144
D103	CR23	1N914, SK3100, ECG177, RS276-1144
D104	SR12	1N4003, SK3017A, ECG117

VCO/AUDIO (EC80)

Circuit Symbol	Part Number	Replace With
Q201	TS43	2N4124, SK3124, ECG108
Q202	TS43	2N4124, SK3124, ECG108
Q203	TS43	2N4124, SK3124, ECG108
Q204	TS47	2N4126, SK3114, ECG159
Q205	TS43	2N4124, SK3124, ECG108
IC201	IG58	MC1458CPI, SK3551
IC202	IG79	MC1648, SP1648
IC203	IG75	CA3086, SK3543, LM3086
IC204	IG66	LM380, ULN2280
IC205	IG80	78L05

OSCILLATOR CIRCUIT BOARD (EC81)

Circuit Symbol	Part Number	Replace With
Q301	TS43	2N4124, ECG108, SK3124, RS276-2009
Q302, 303	TS53, TS43	3N204, 2N4124, ECG108, SK3124 RS276-2009
Q304	TS43	2N4124, ECG108, SK3124, RS276-2009
IC301	IG75	CA3086, SK3543, LM3086
IC302	IG5	7400N, RS276-1801
IC303	IG50	7490
IC304	IG50	7490
IC305	IG50	7490
IC306	IG42	7492
D301	CR23	1N914, ECG177, SK3100, RS276-1144
D302	CR23	1N914, ECG177, SK3100, RS276-1144
D303	CR23	1N914, ECG177, SK3100, RS276-1144
D304	CR23	1N914, ECG177, SK3100, RS276-1144
D305	CR23	1N914, ECG177, SK3100, RS276-1144

RECEIVER CIRCUIT BOARD (EC82)

Circuit Symbol	Part Number	Replace With
IC401	IG82	MC1550, HEP590
IC402	IG81	CA3053, LM3053, LS3053
IC403	IG82	MC1550, HEP590
IC404	IG29	CA3065, MC1358, UA3065, ULN2165, HEPC6083P, SK3072, ECG712
Q401	TS53	3N204
Q402	TS53	3N204
Q403	TS56	MRF502, SK3039, RS276-2011
Q404	TS56	MRF502, SK3039, RS276-2011

RF/POWER SUPPLY (EC83)

Circuit Symbol	Part Number	Replace With
Q501	TS39	2N3053, ECG128, SK3024, RS276-2030
Q502	TS56	MRF502, SK3039, RS276-2011
Q503	TS54	2N5770, RS276-2011
Q504	TS55	2N3866, ECG128, SK3048, RS276-2009
CR501	CR23	1N914, ECG177, SK3100, RS276-1144
CR502	CR32	1N5242B, ECG142, SK3062, RS276-563, ECG5021

(continued on next page)

DISPLAY (EC84)

Circuit Symbol	Part Number	Replace With
D601	LP17	1N5910
D602	LP26	FLV410
D603	CR23	1N914, SK3100, RS276-1144
D604	CR23	1N914, SK3100, RS276-1144
DS601	LP21	DL707
DS602	LP21	DL707
DS603	LP21	DL707
DS604	LP21	DL707
DS605	LP28	DL701

DISPLAY DRIVER (EC85)

Circuit Symbol	Part Number	Replace With
IC701	IG51	7447 PC
IC702	IG51	7447 PC
IC703	IG51	7447 PC

POWER AMPLIFIER (EC86)

Circuit Symbol	Part Number	Replace With
IC801	IG83	(TRW) MV20, (MOT) MHW602

CHASSIS

Circuit Symbol	Part Number	Replace With
IC901	IG44	LM309, μ a 309
D901	SR19	2AF1, ECG5800, ECG5801, RS276-1141, RS276-1142

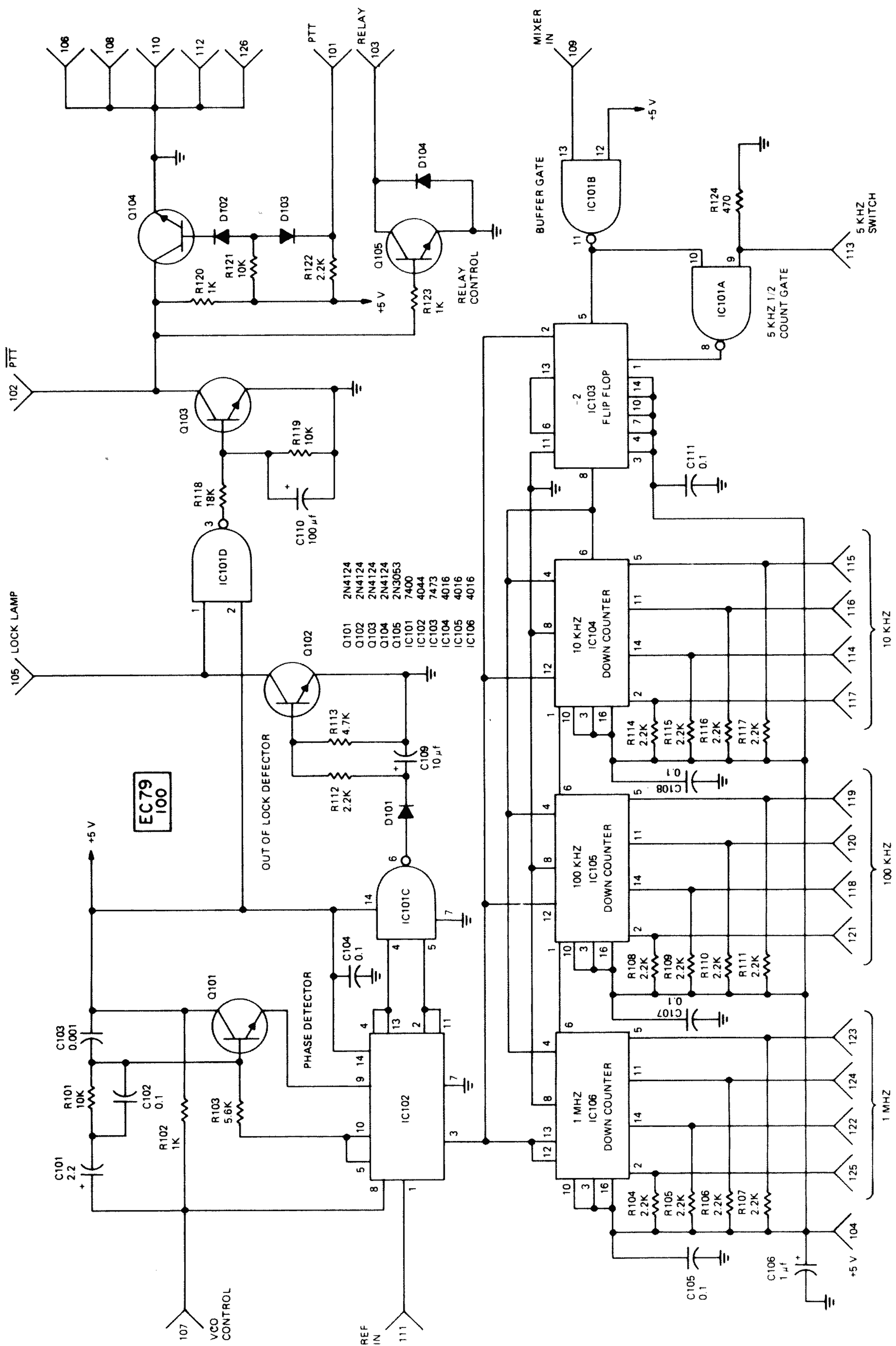

Fig. 3. Programmable divider circuit board schematic.

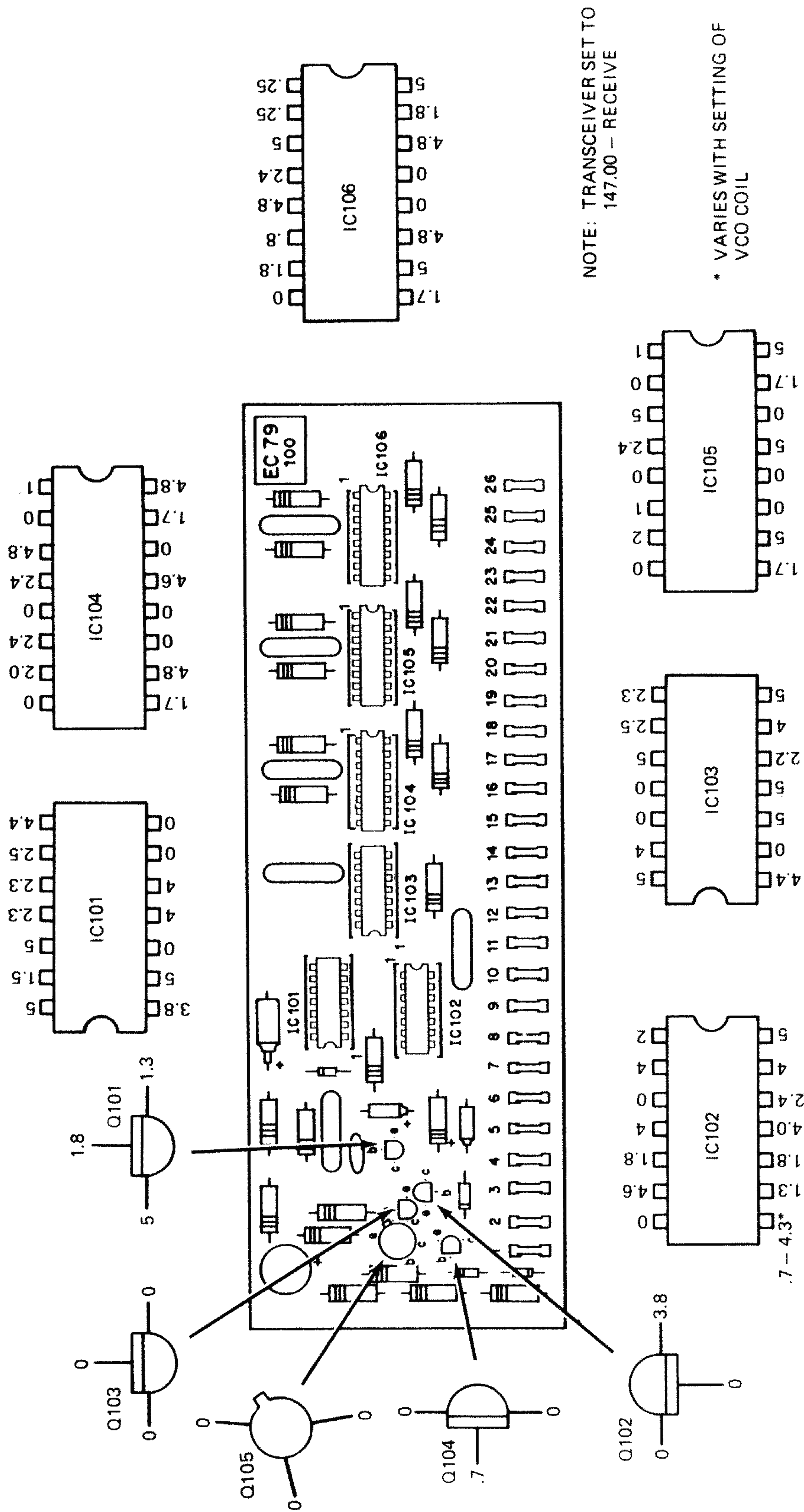

Fig. 4. Normal operating voltages on the programmable divider circuit board.

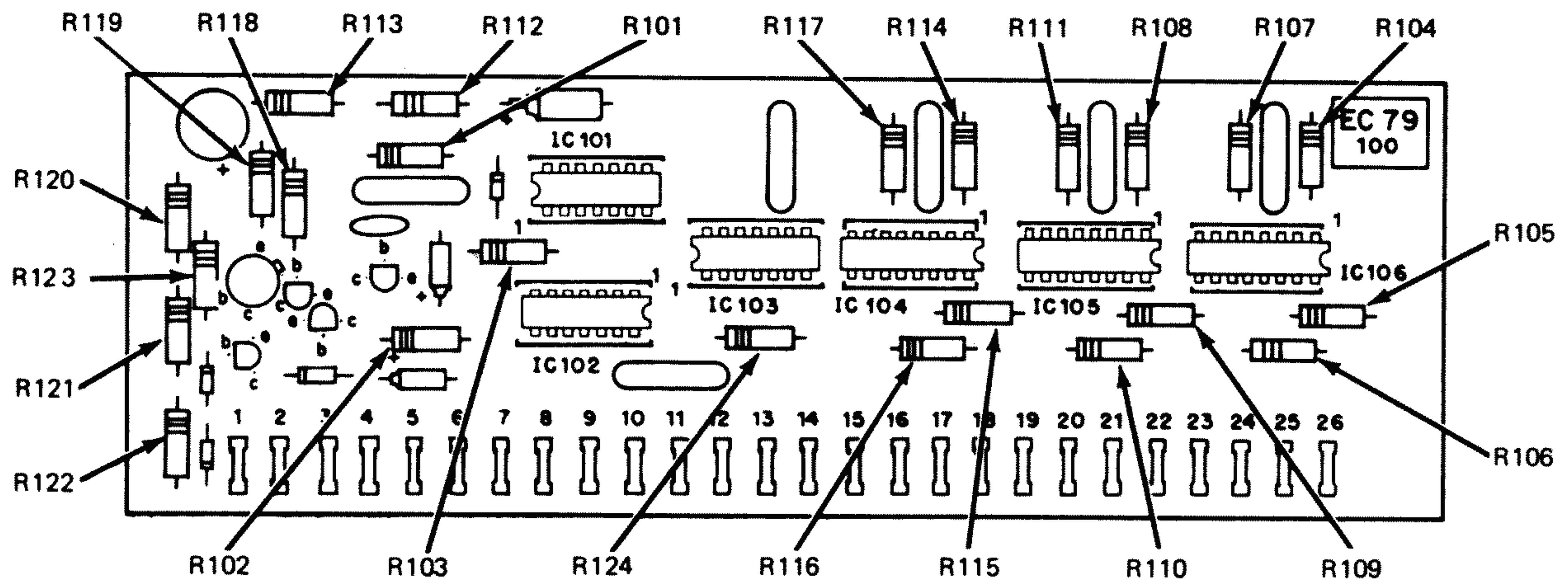

Fig. 5. Resistor identification on the programmable divider circuit board.

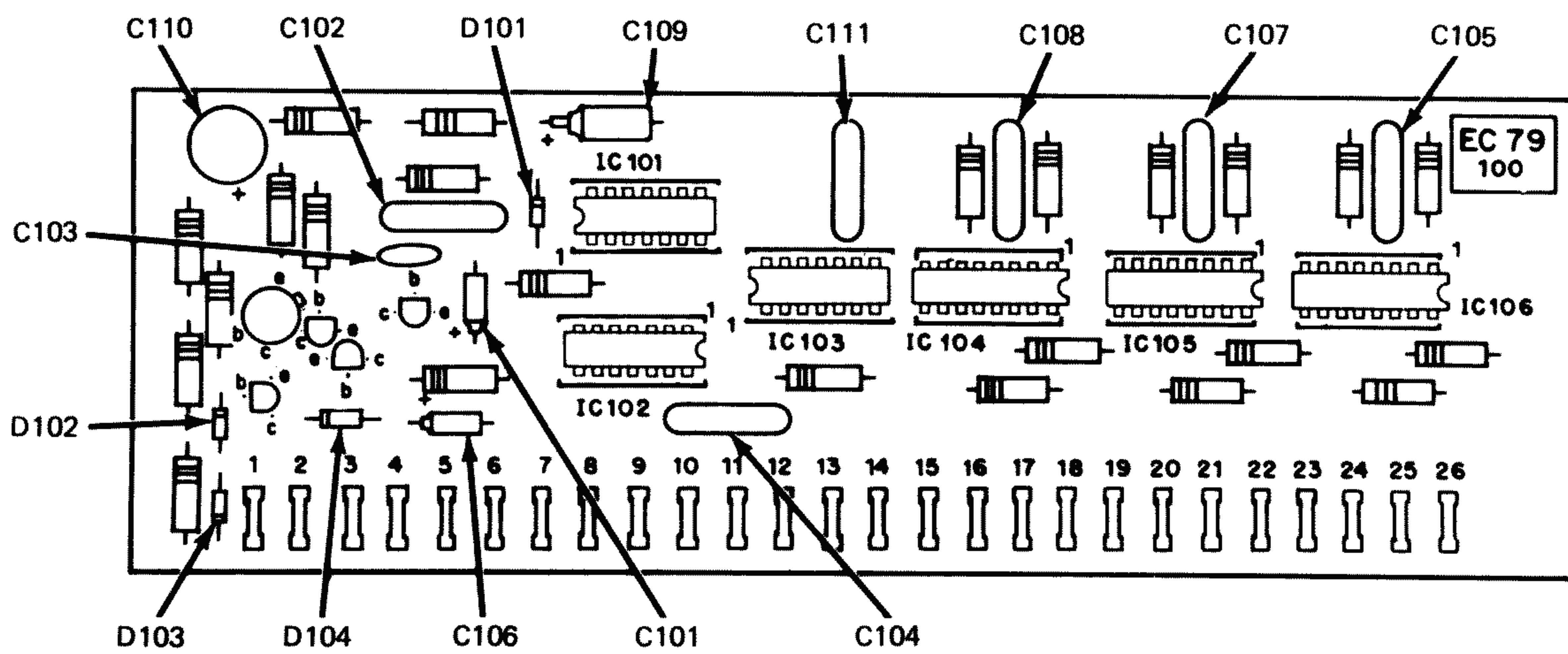

Fig. 6. Diode and capacitor identification on the programmable divider circuit board.

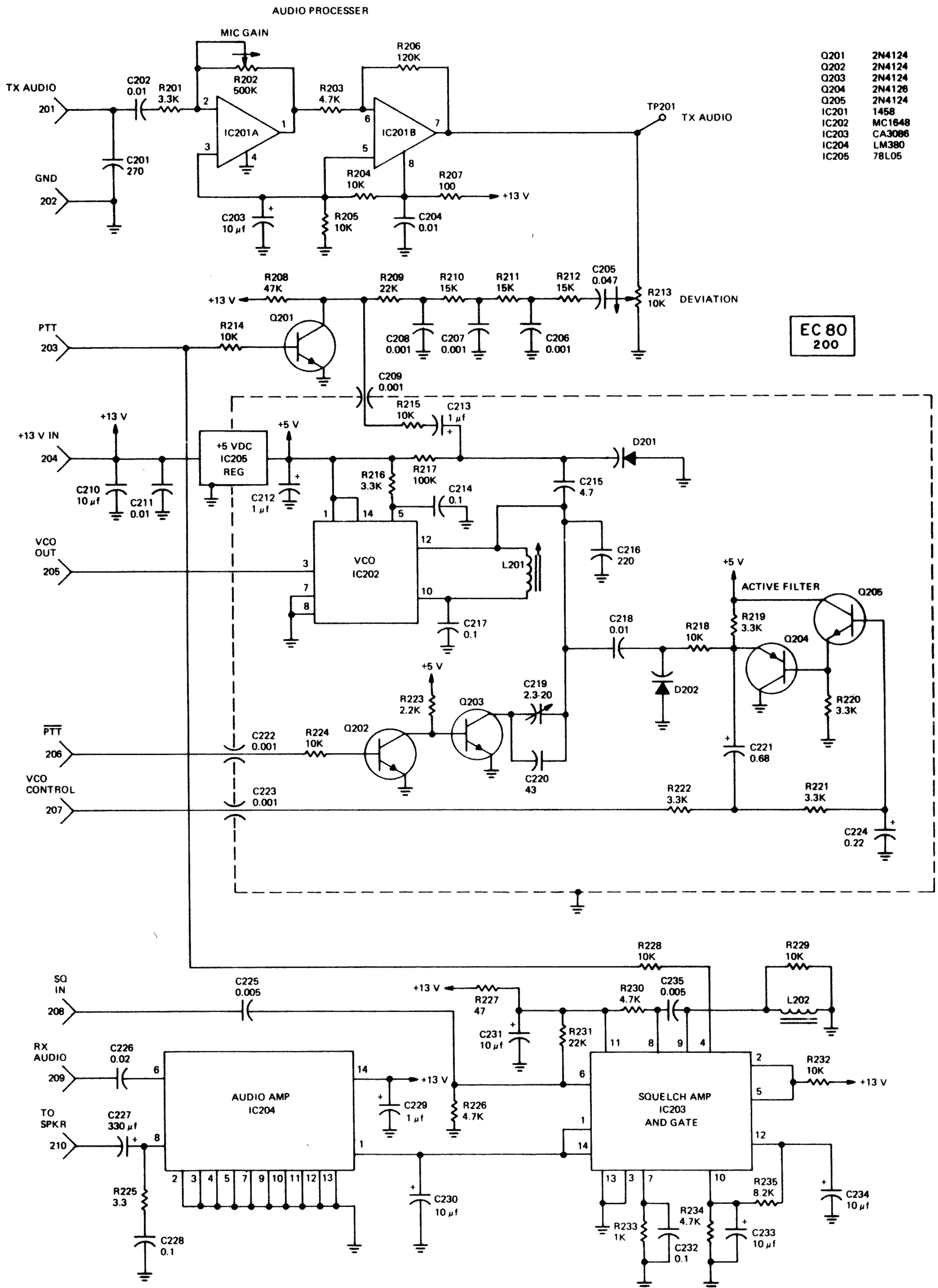

Fig. 7. VCO/audio circuit board schematic.

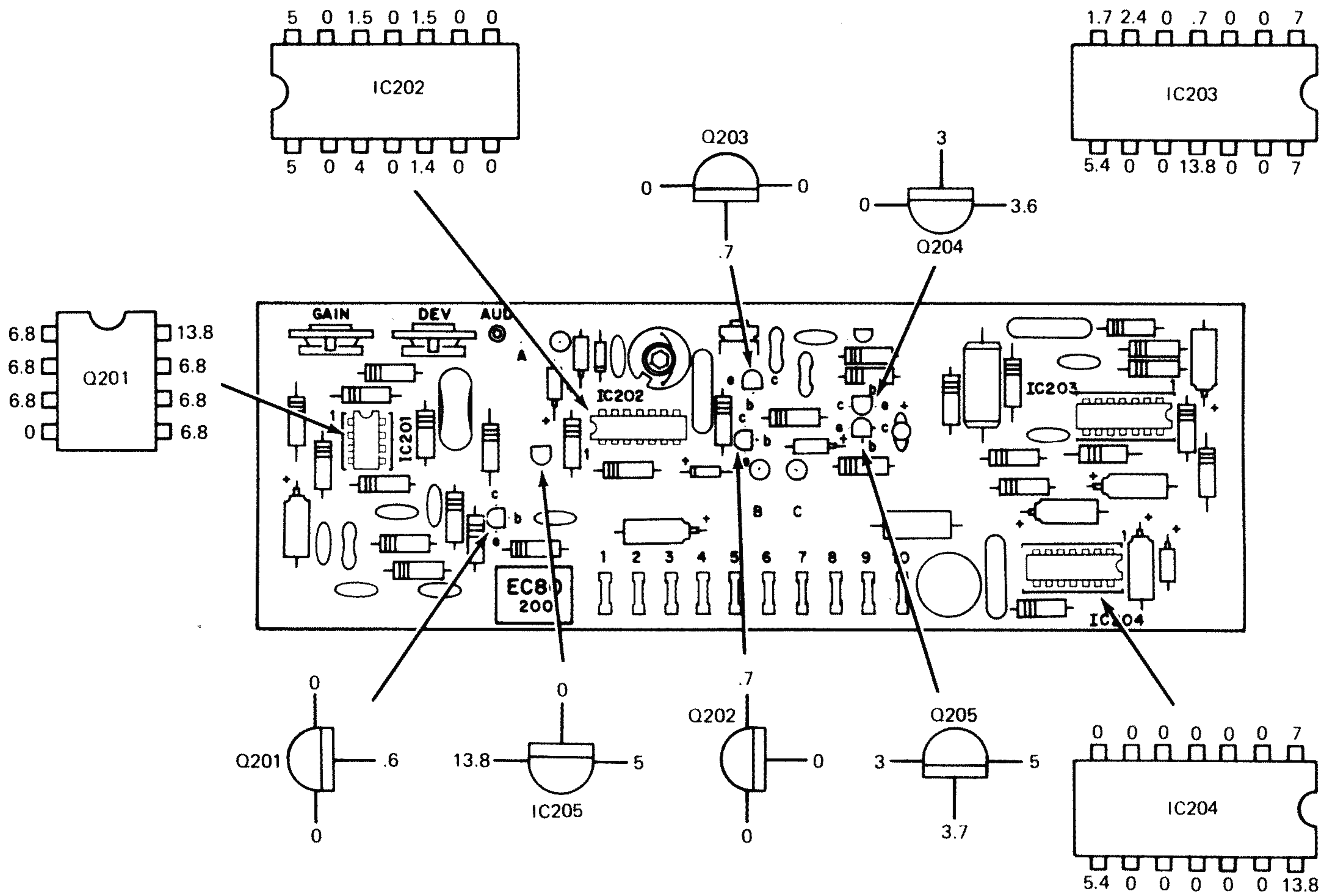

Fig. 8. Normal operating voltages on the VCO/audio circuit board.

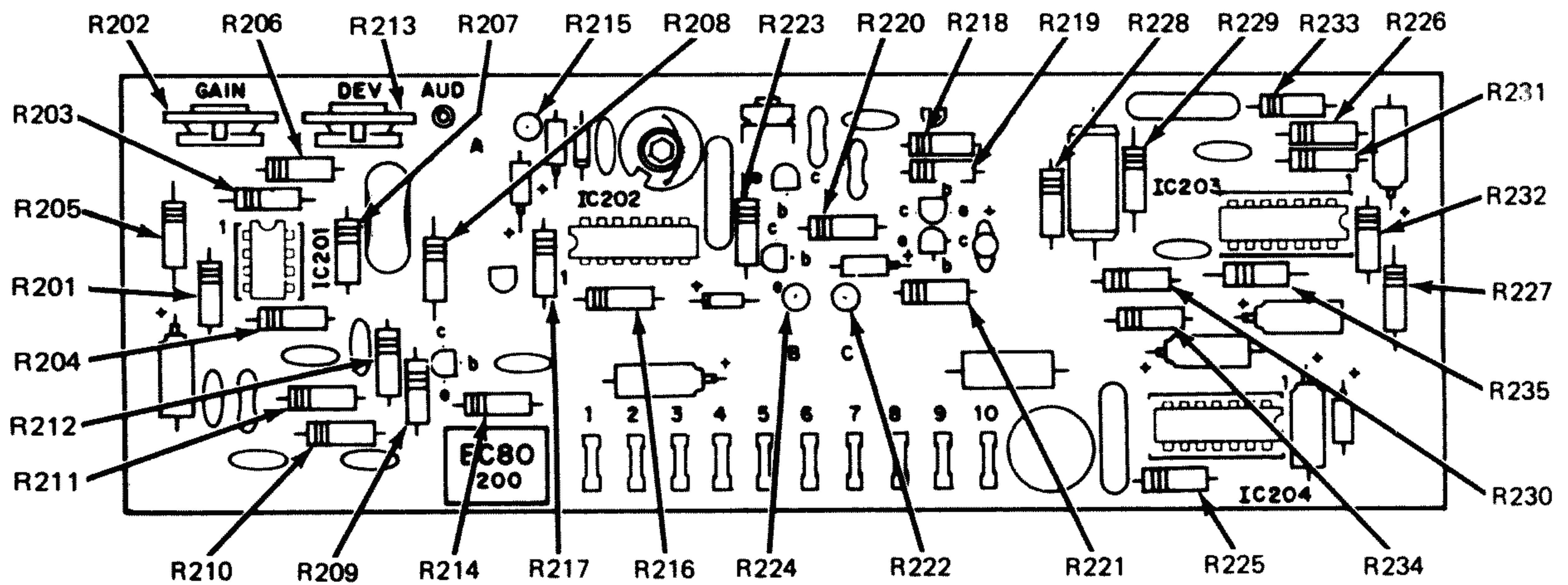

Fig. 9. Resistor identification on the VCO/audio circuit board.

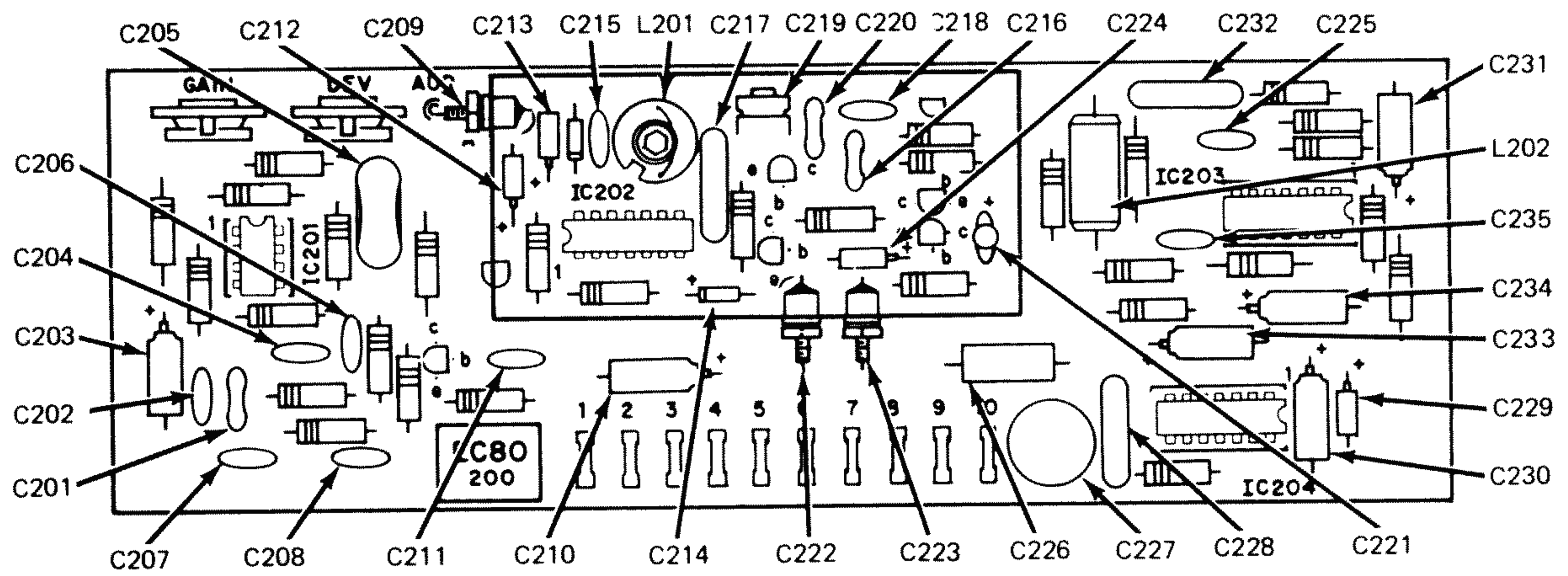

Fig. 10. Capacitor and coil identification on the VCO/audio circuit board.

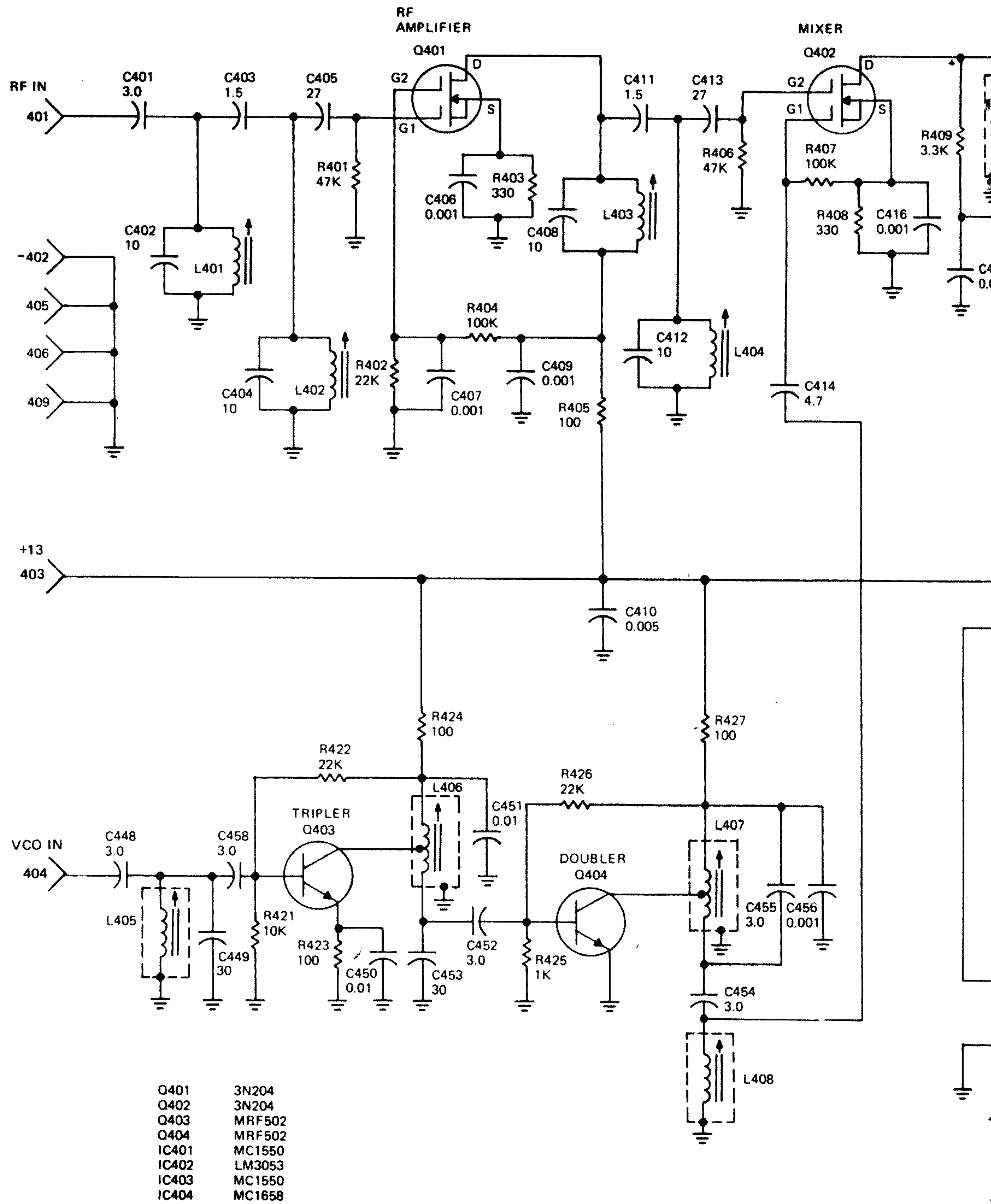

Fig. 16. Receiver circuit

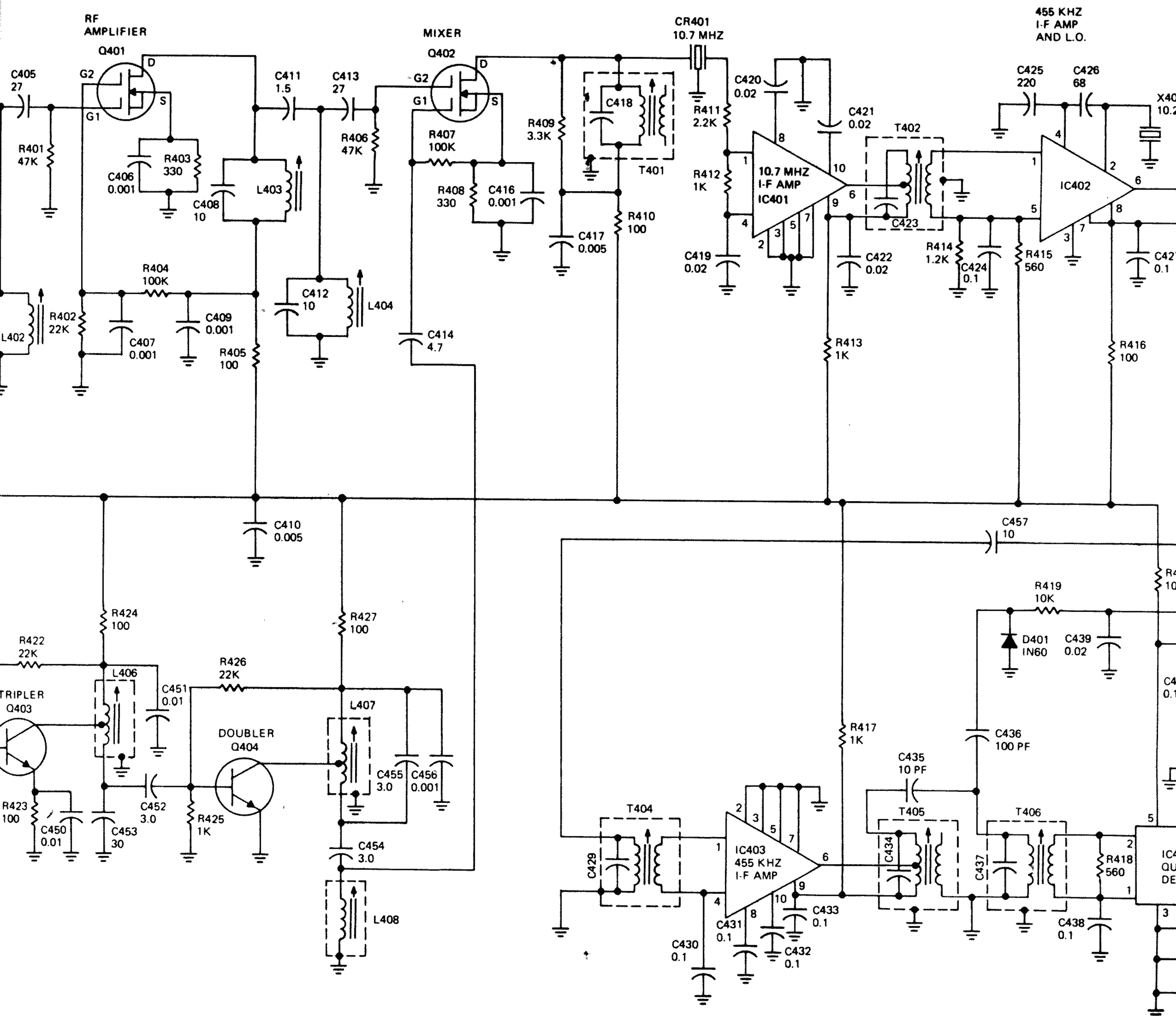
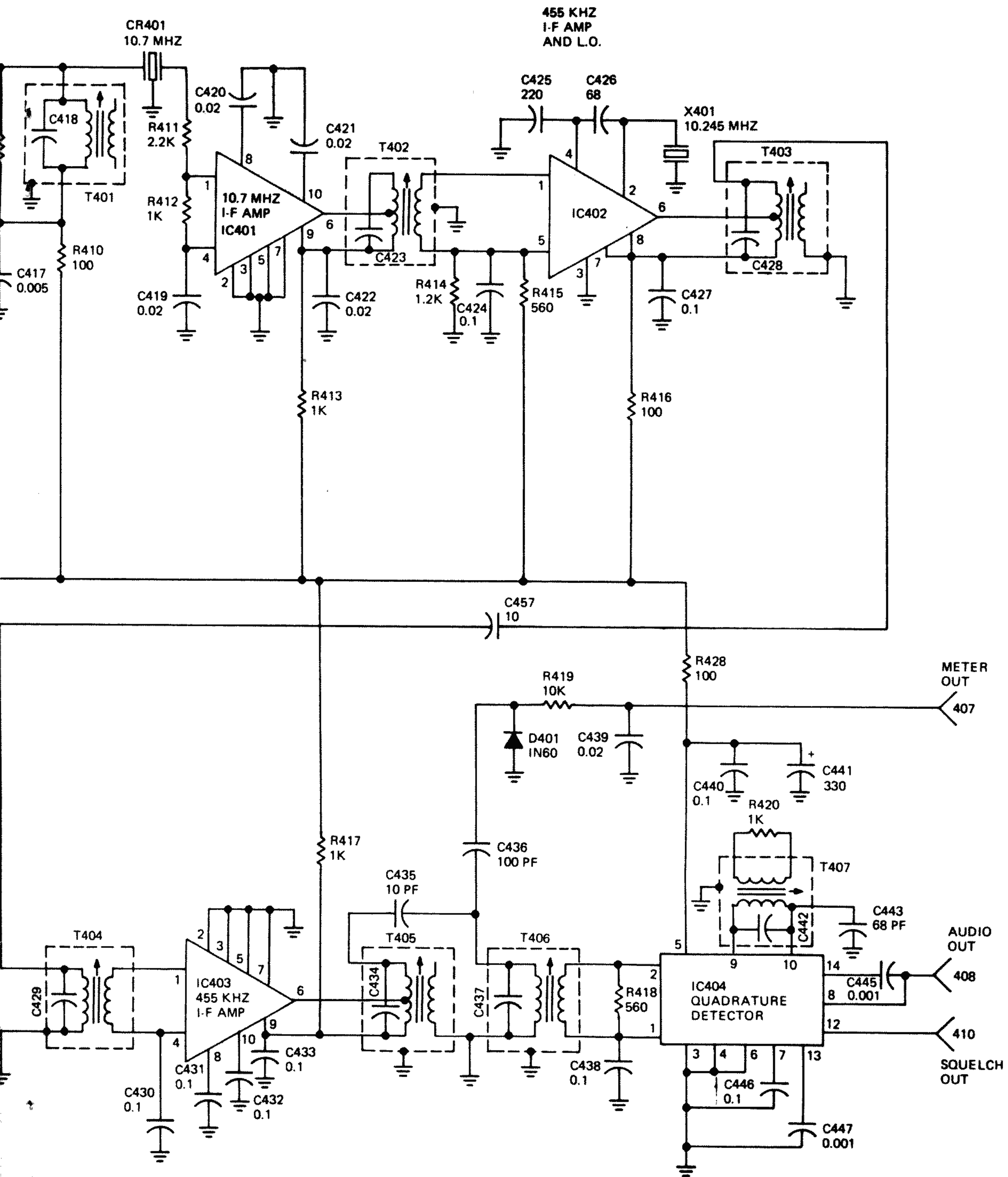

Fig. 16. Receiver circuit board schematic.



er circuit board schematic.

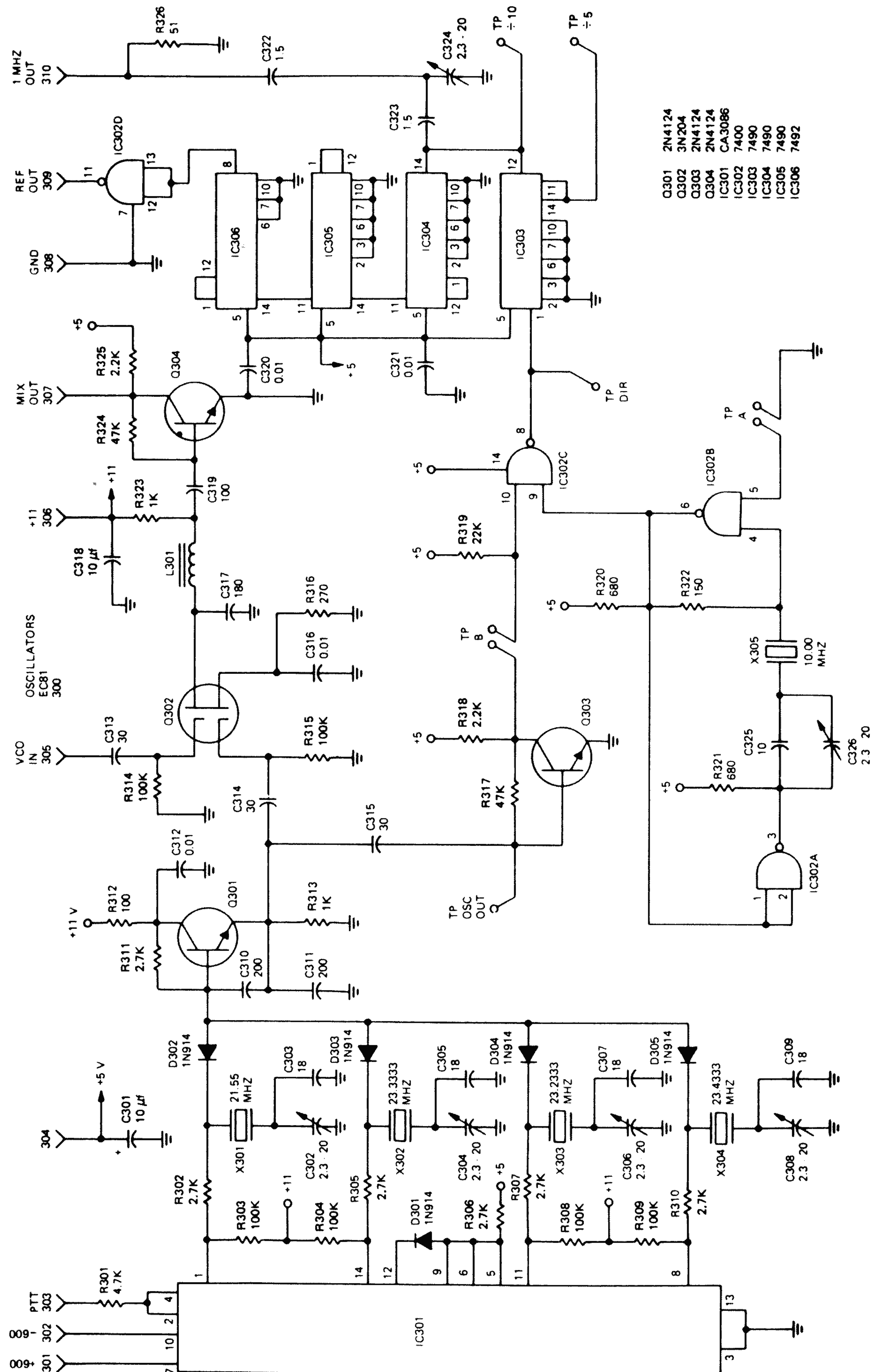

Fig. 11. The oscillator/mixer circuit board schematic.

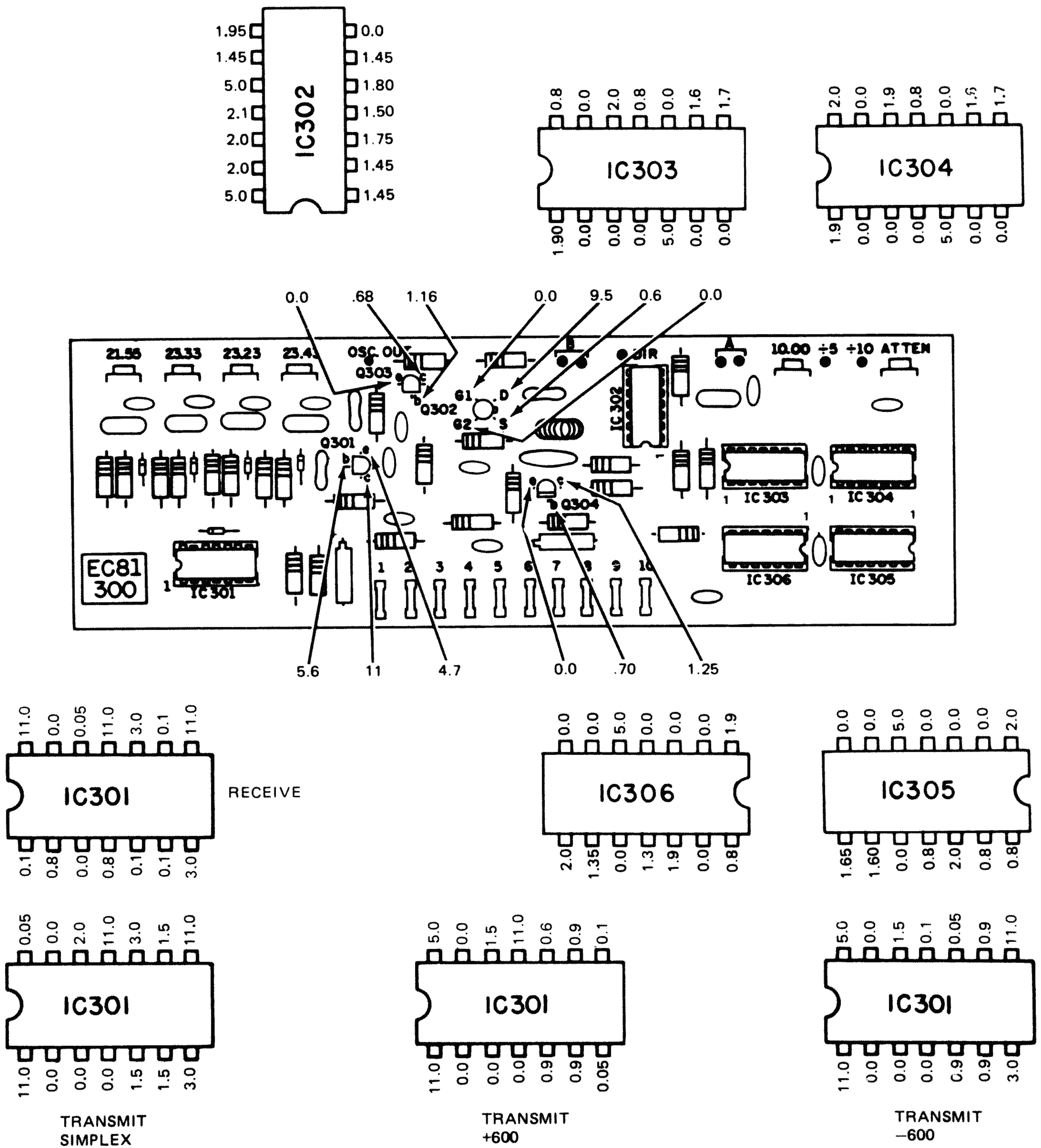

Fig. 12. Normal operating voltages on the oscillator circuit board.

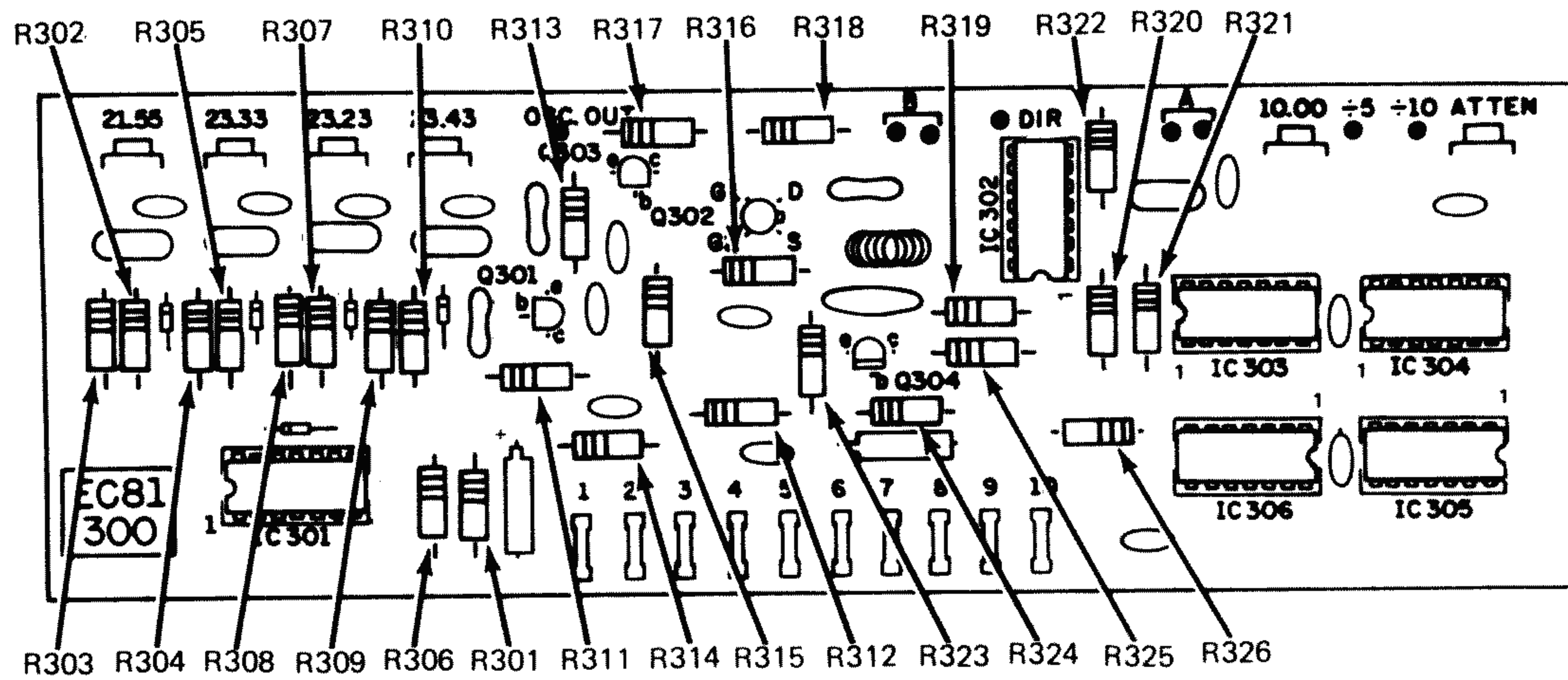

Fig. 13. Resistor identification on the oscillator circuit board.

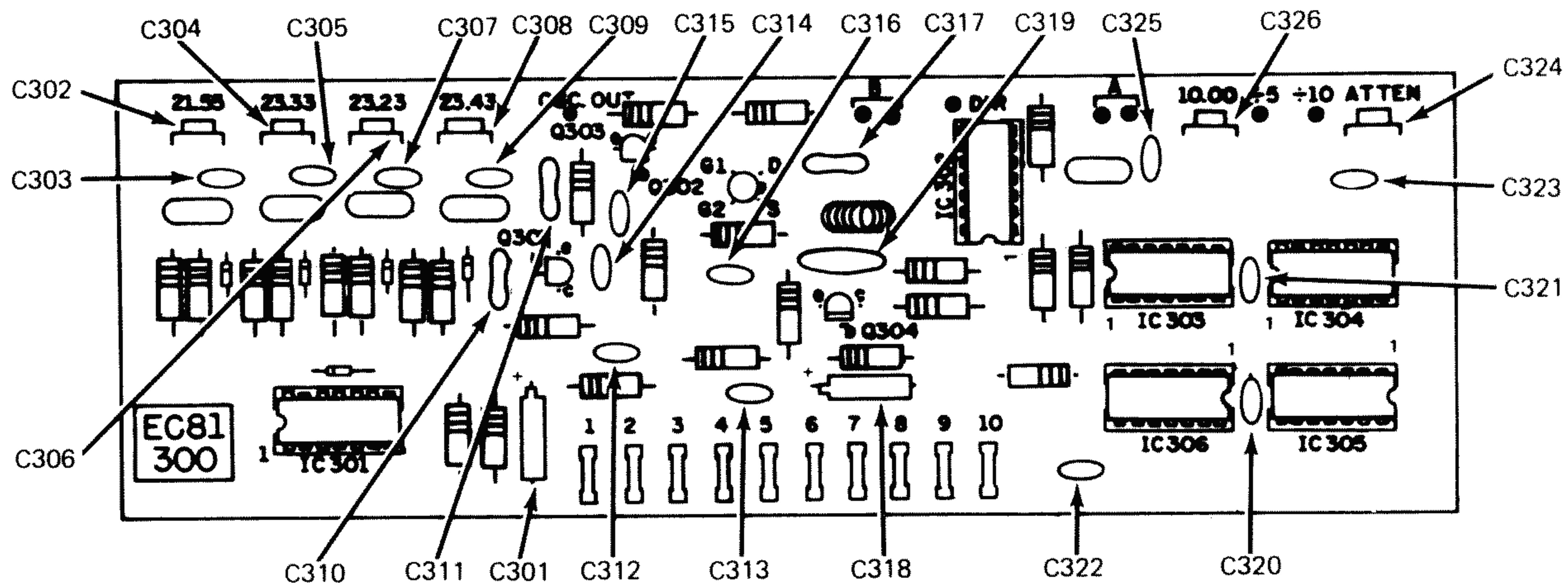

Fig. 14. Capacitor identification on the oscillator circuit board.

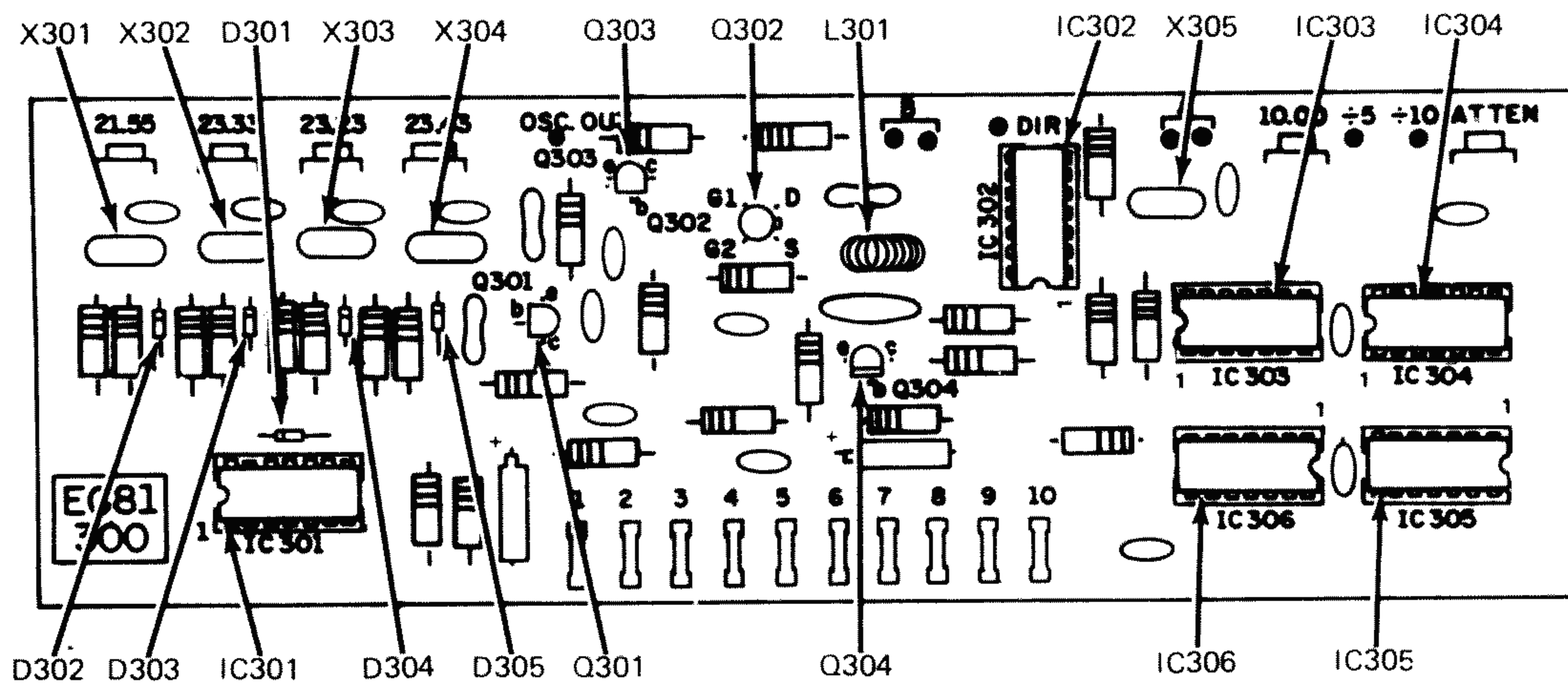

Fig. 15. Miscellaneous parts identification on the oscillator circuit board.

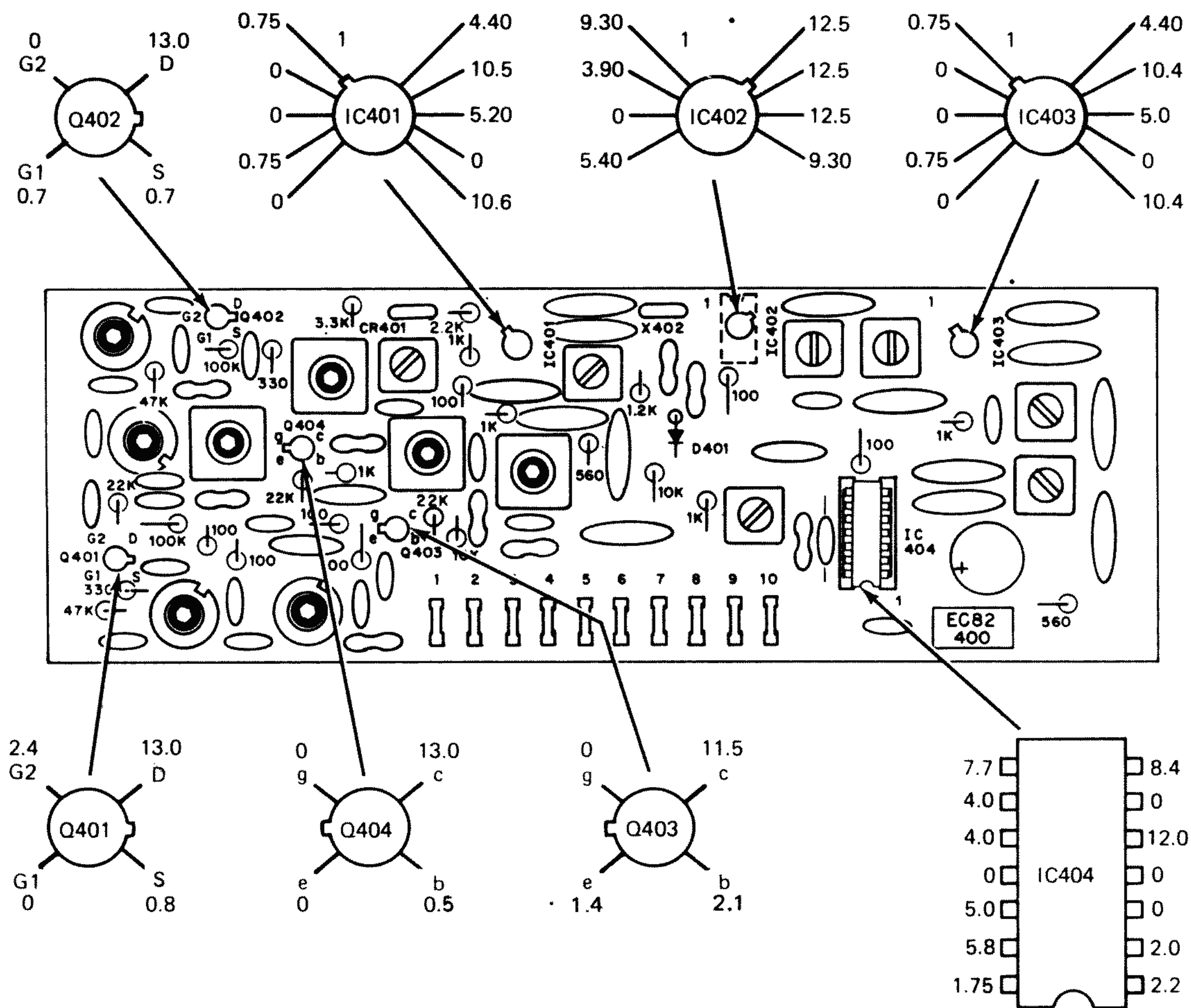

Fig. 17. Normal operating voltages on the receiver circuit board.

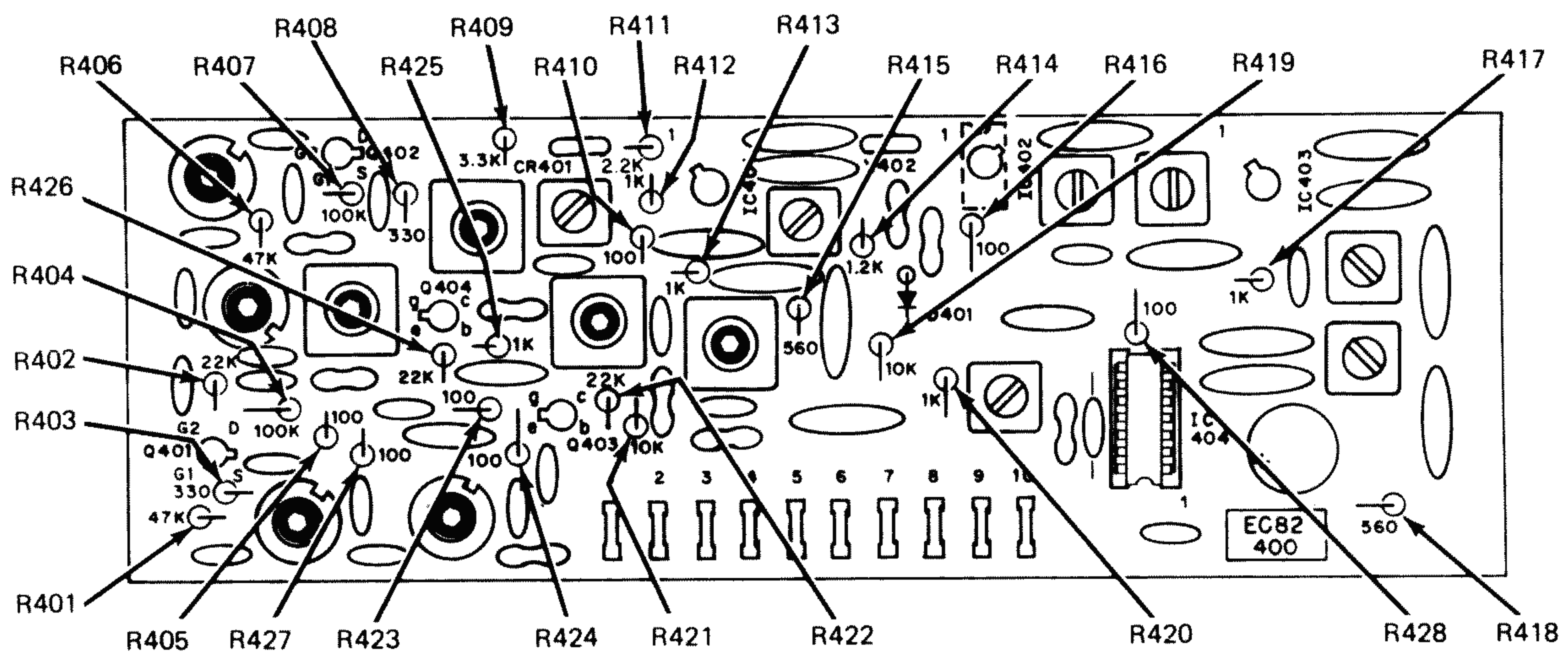

Fig. 18. Resistor identification on the receiver circuit board.

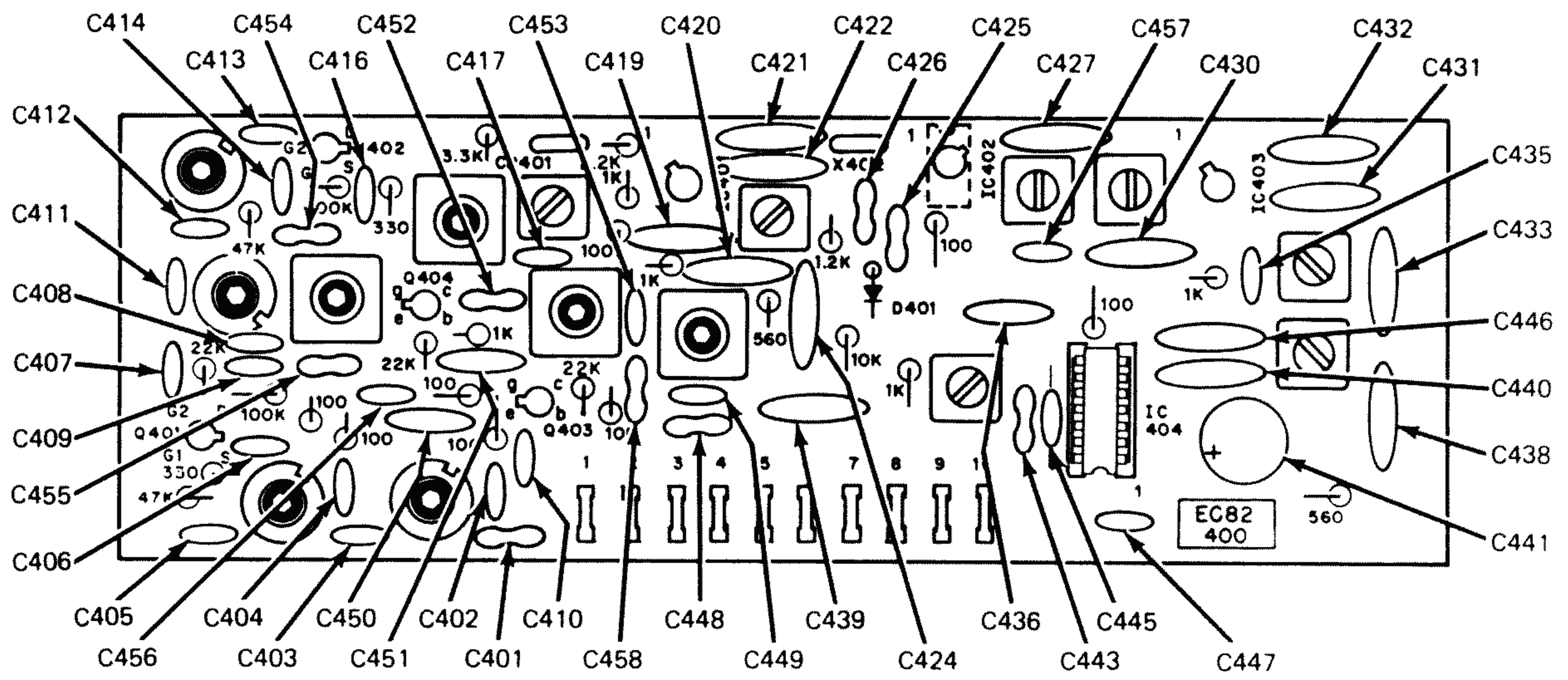

Fig. 19. Capacitor identification on the receiver circuit board.

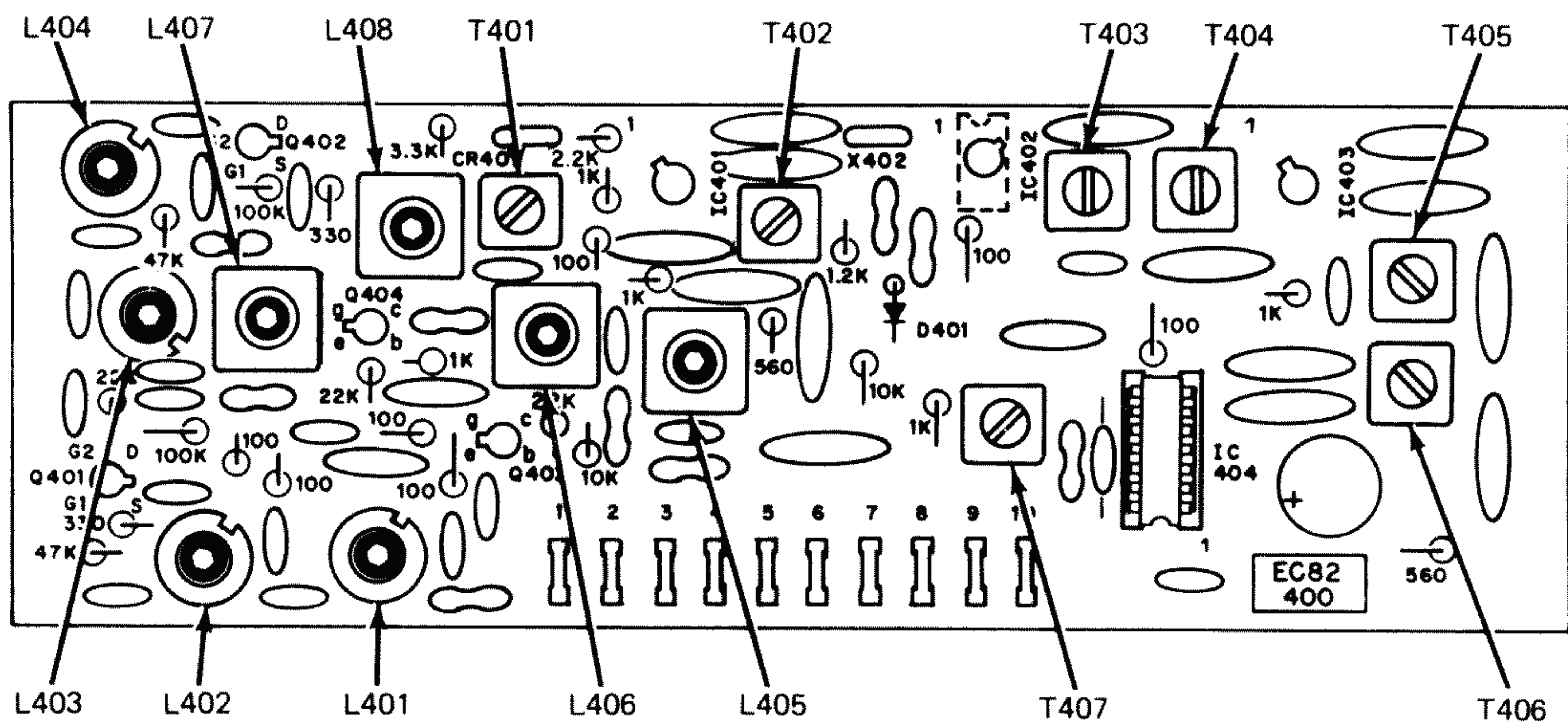
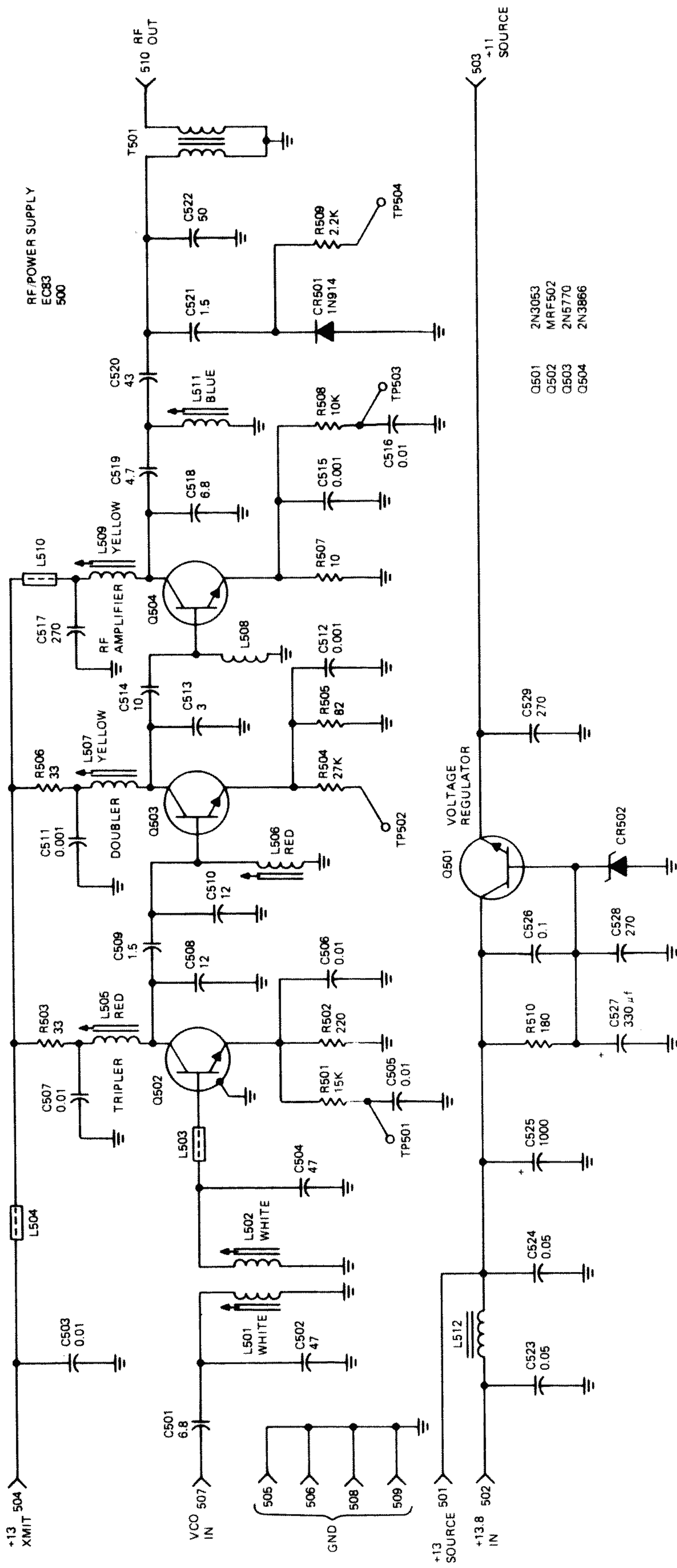

Fig. 20. Coil and transformer identification on the receiver circuit board.



- Q501 2N3053
- Q502 MRF502
- Q503 2N5770
- Q504 2N3866

Fig. 21. The rf/power supply circuit board schematic.

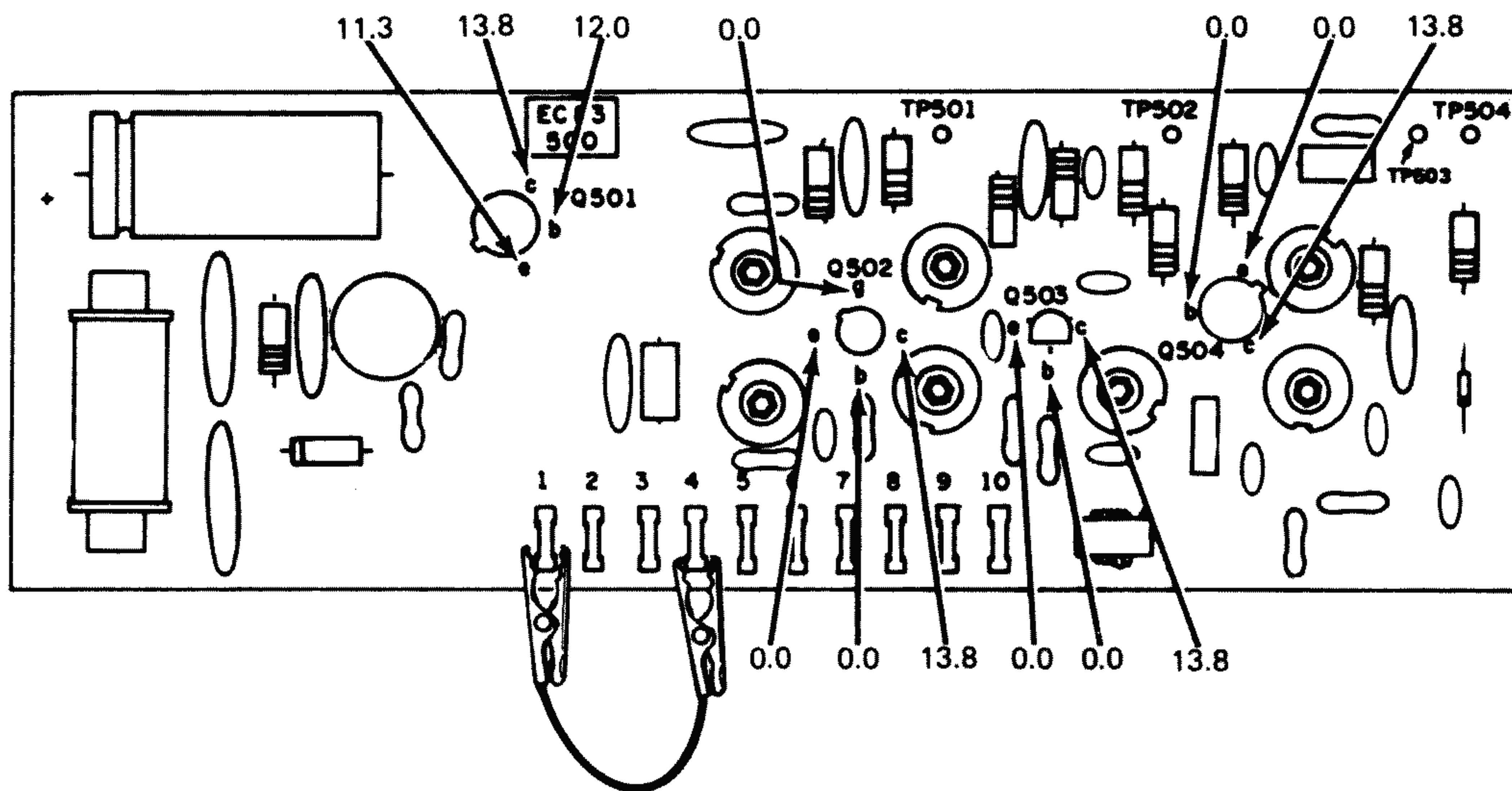

Fig. 22. Normal operating voltages on the rf/power supply circuit board.

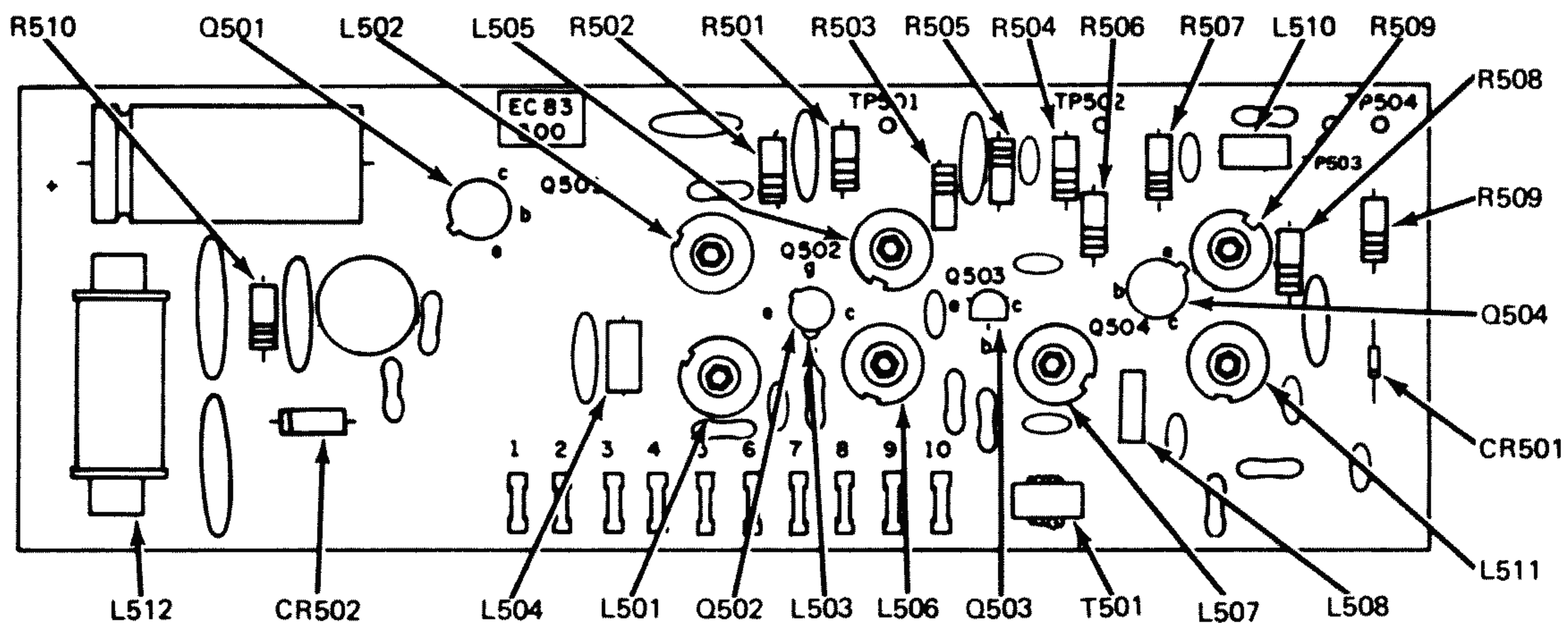

Fig. 23. Resistor and miscellaneous parts identification on the rf/power supply circuit board.

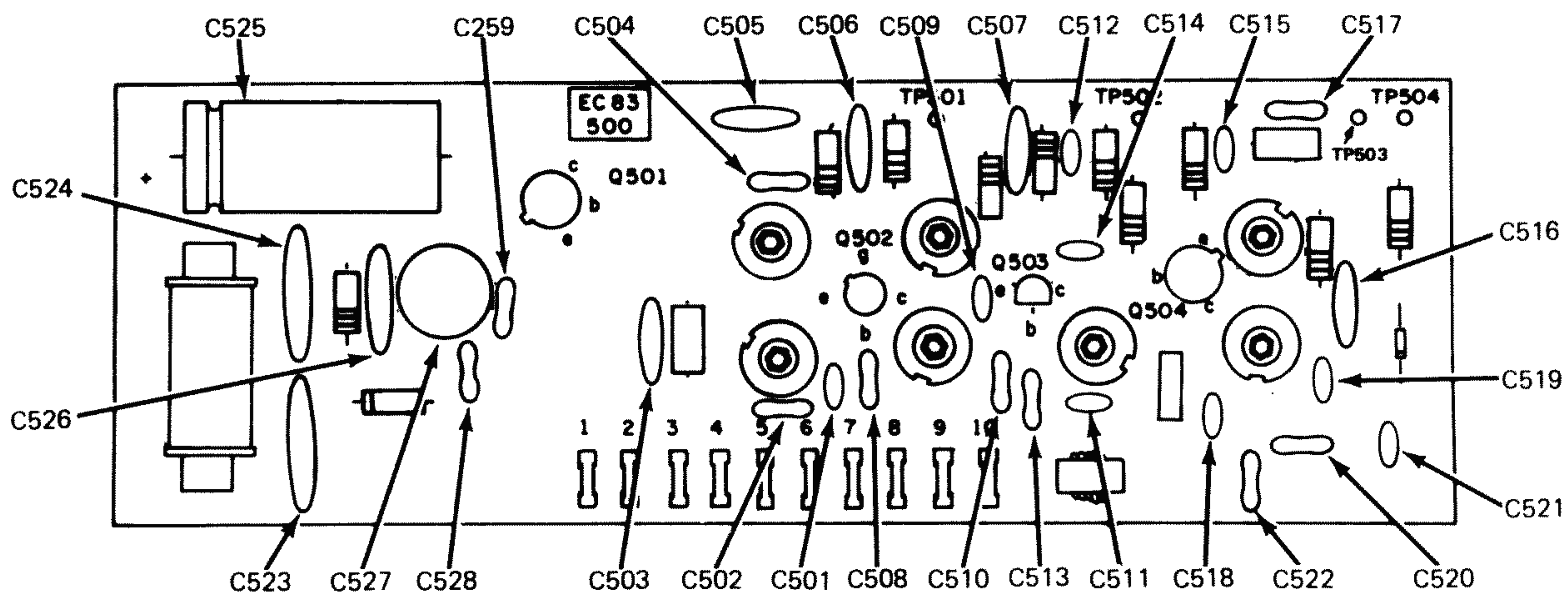
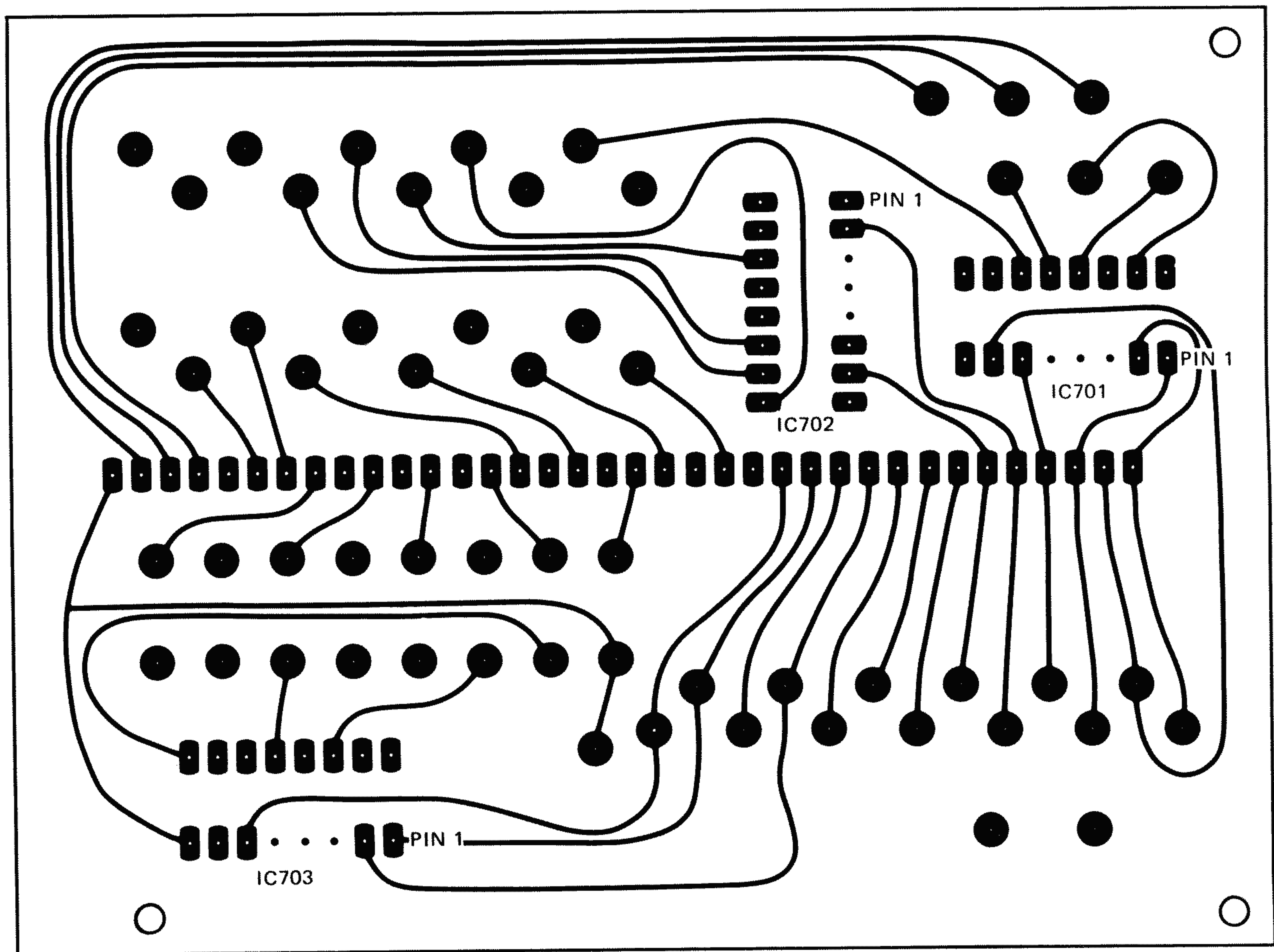

Fig. 24. Capacitor identification on the rf/power supply circuit board.



	1	2	3	4	5	6	7	8	9	10	11	12	13	14	15	16
0	0	0	NC	NC	NC	0	0	0	+0.2	+0.2	+0.2	+0.2	+0.2	+4	+0.2	+5
1	0	0	NC	NC	NC	0	+1.7	0	+4	+4	+0.2	+0.2	+4	+4	+4	+5
2	+1.7	0	NC	NC	NC	0	0	0	+0.2	+0.2	+4	+0.2	+0.2	+0.2	+4	+5
3	+1.7	0	NC	NC	NC	0	+1.7	0	+4	+0.2	+0.2	+0.2	+0.2	+0.2	+4	+5
4	0	+1.7	NC	NC	NC	0	0	0	+4	+4	+0.2	+0.2	+4	+0.2	+0.2	+5
5	0	+1.7	NC	NC	NC	0	+1.7	0	+4	+0.2	+0.2	+4	+0.2	+0.2	+0.2	+5
6	+1.7	+1.7	NC	NC	NC	0	0	0	+0.2	+0.2	+0.2	+4	+4	+0.2	+0.2	+5
7	+1.7	+1.7	NC	NC	NC	0	+1.7	0	+4	+4	+0.2	+0.2	+0.2	+4	+4	+5
8	0	0	NC	NC	NC	+1.7	0	0	+0.2	+0.2	+0.2	+0.2	+0.2	+0.2	+0.2	+5
9	0	0	NC	NC	NC	+1.7	+1.7	0	+4	+4	+0.2	+0.2	+0.2	+0.2	+0.2	+5

Fig. 26. Operating voltages for IC701, IC702, and IC703. Pin numbers for the ICs are across the top of the chart. The numbers to the left of the chart are the settings of the front panel frequency selector switches, digits 0 through 9. Adjust the 1 MHz switch to check IC701. Adjust the 100 kHz switch to check IC702. Adjust the 10 kHz switch to check IC703.

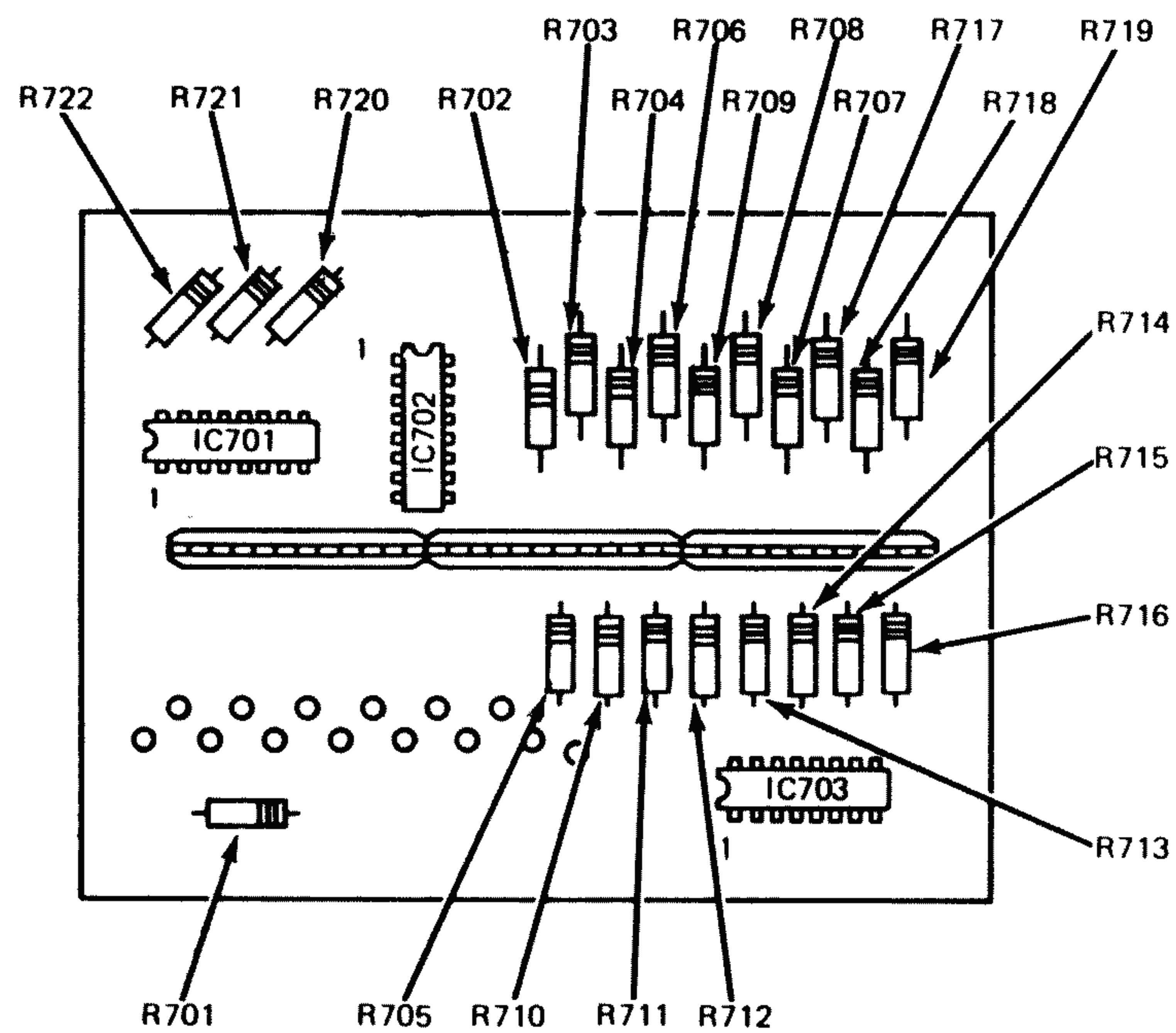

Fig. 27. Parts identification on the display driver circuit board.

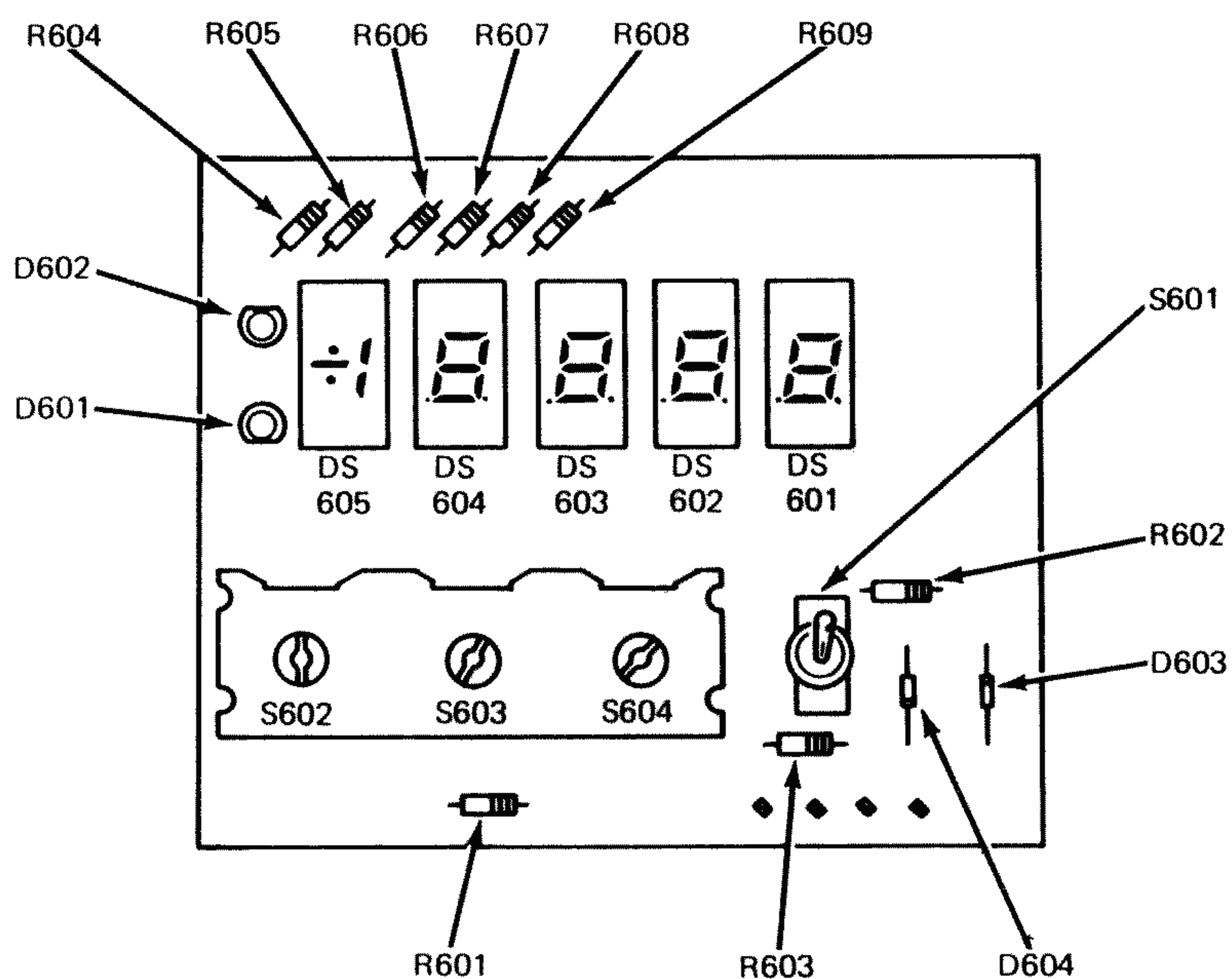
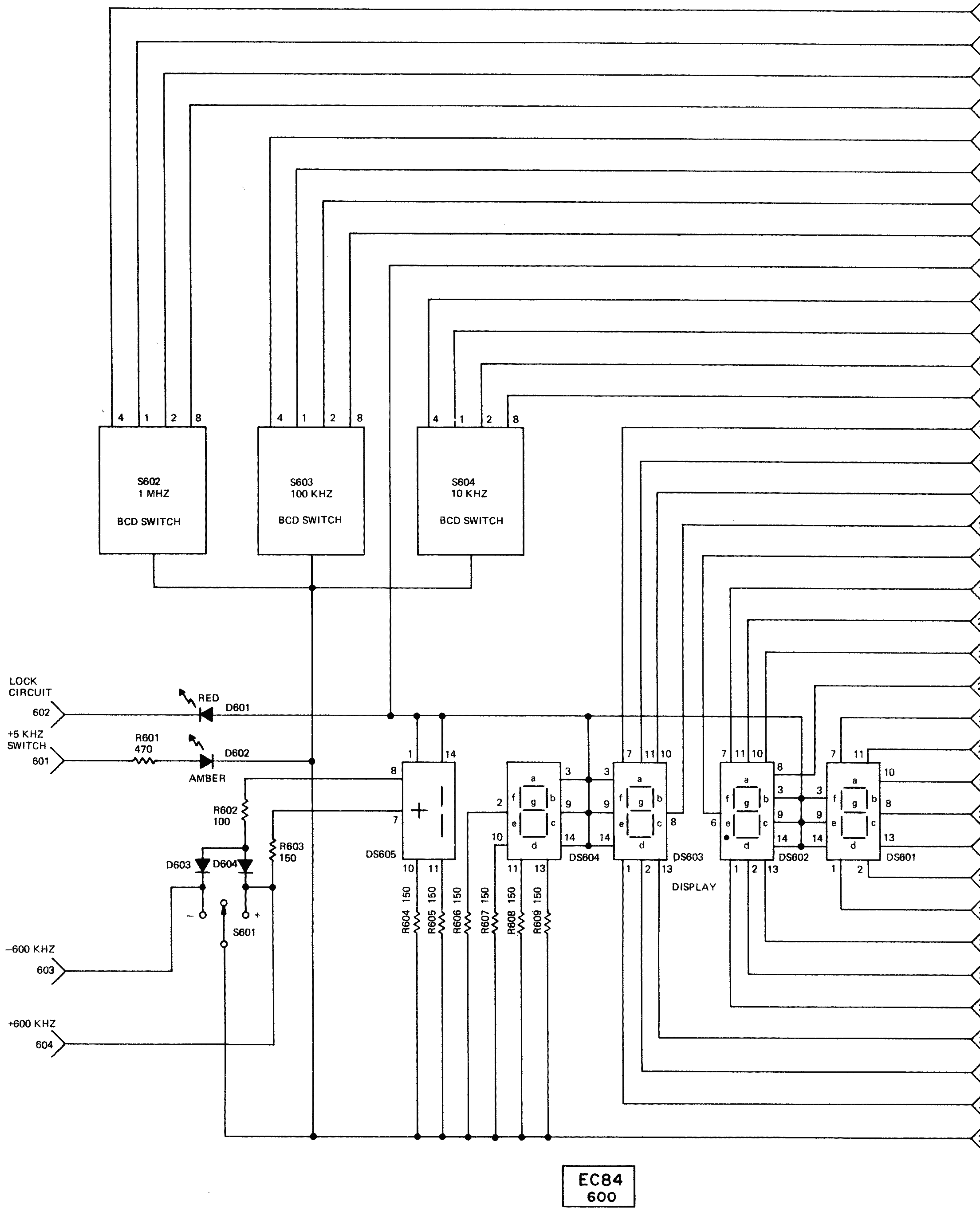

Fig. 28. Parts identification on the display circuit board.



EC84
600

Fig. 25. Display assem

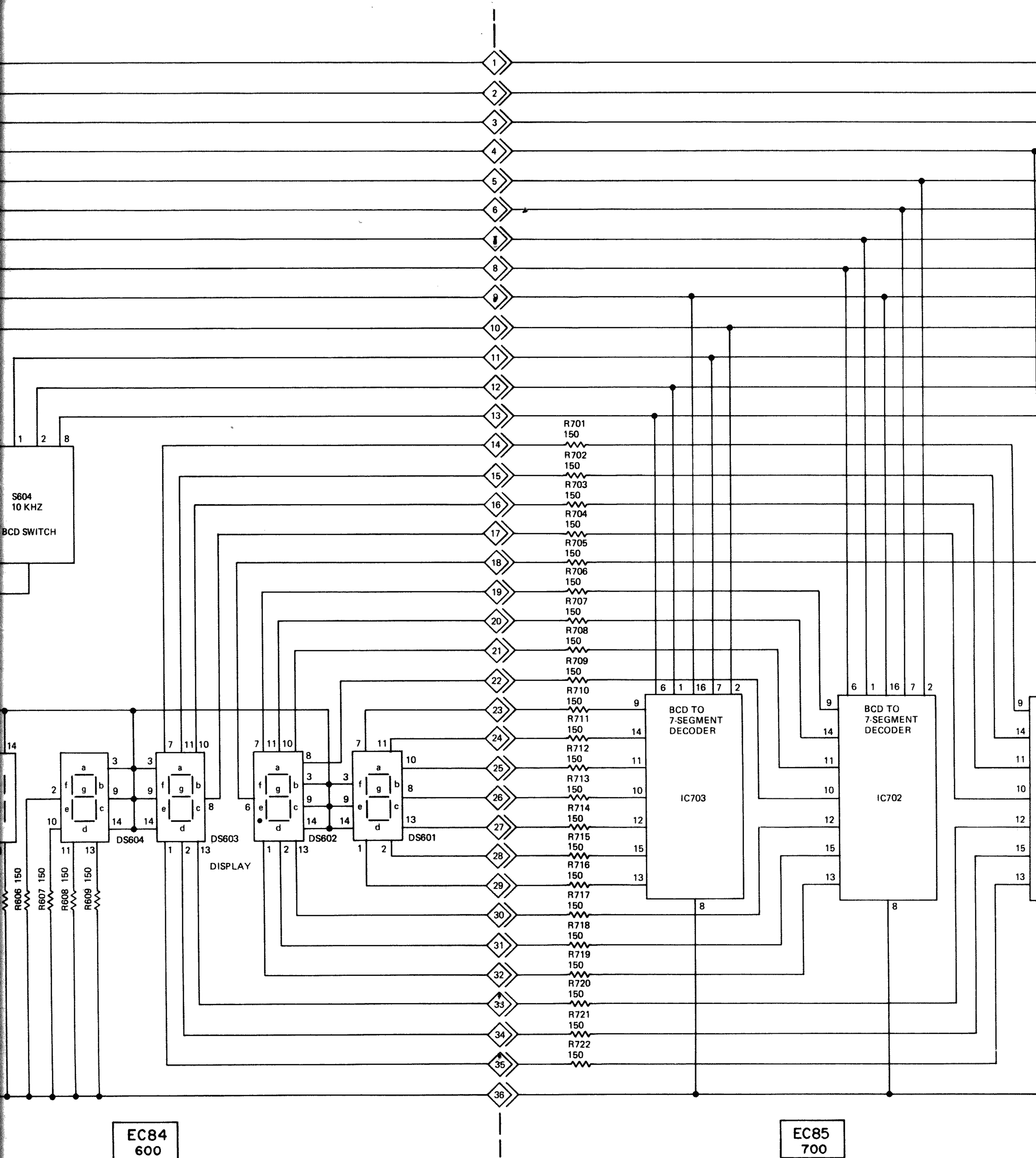
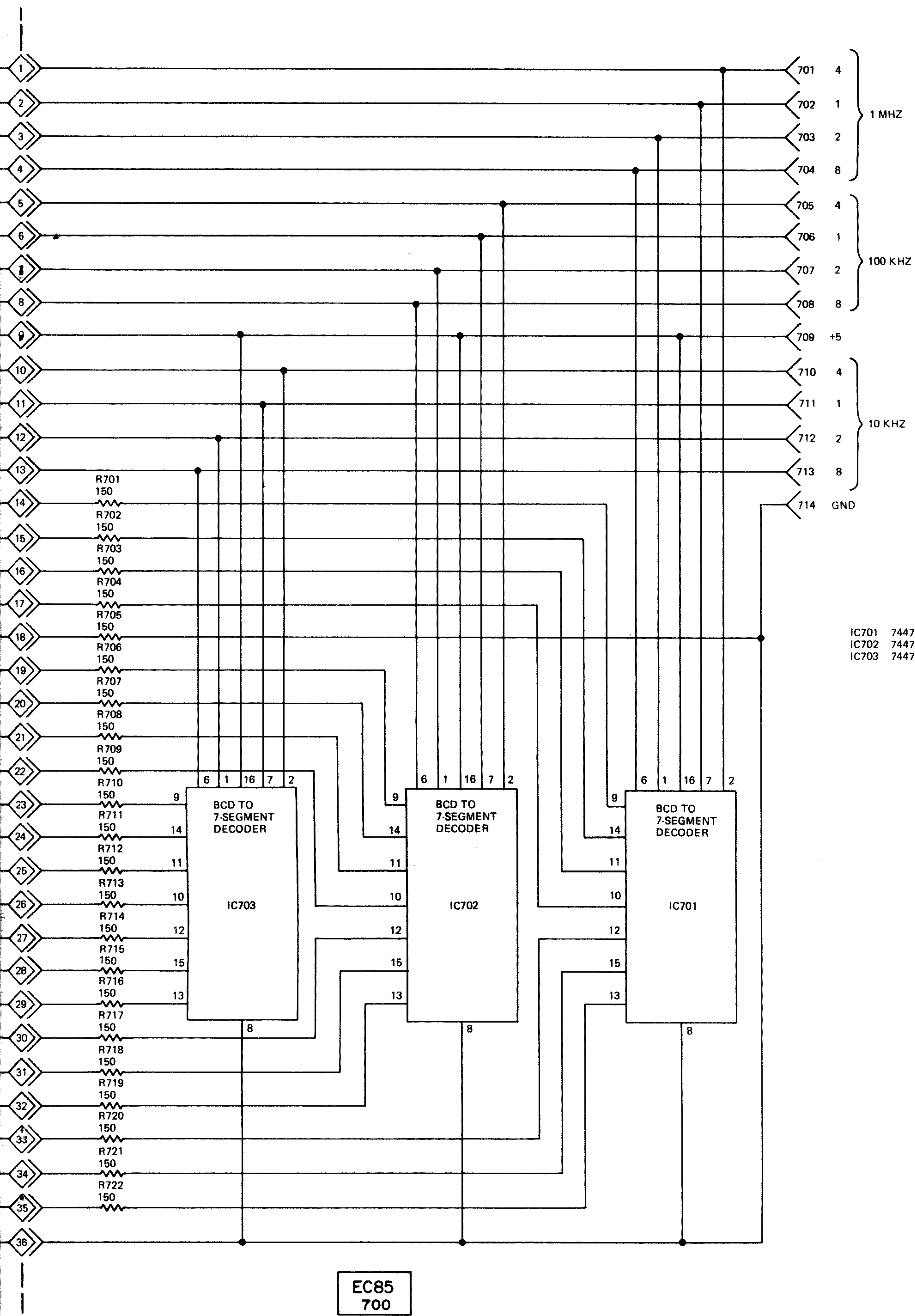

Fig. 25. Display assembly circuit schematic.



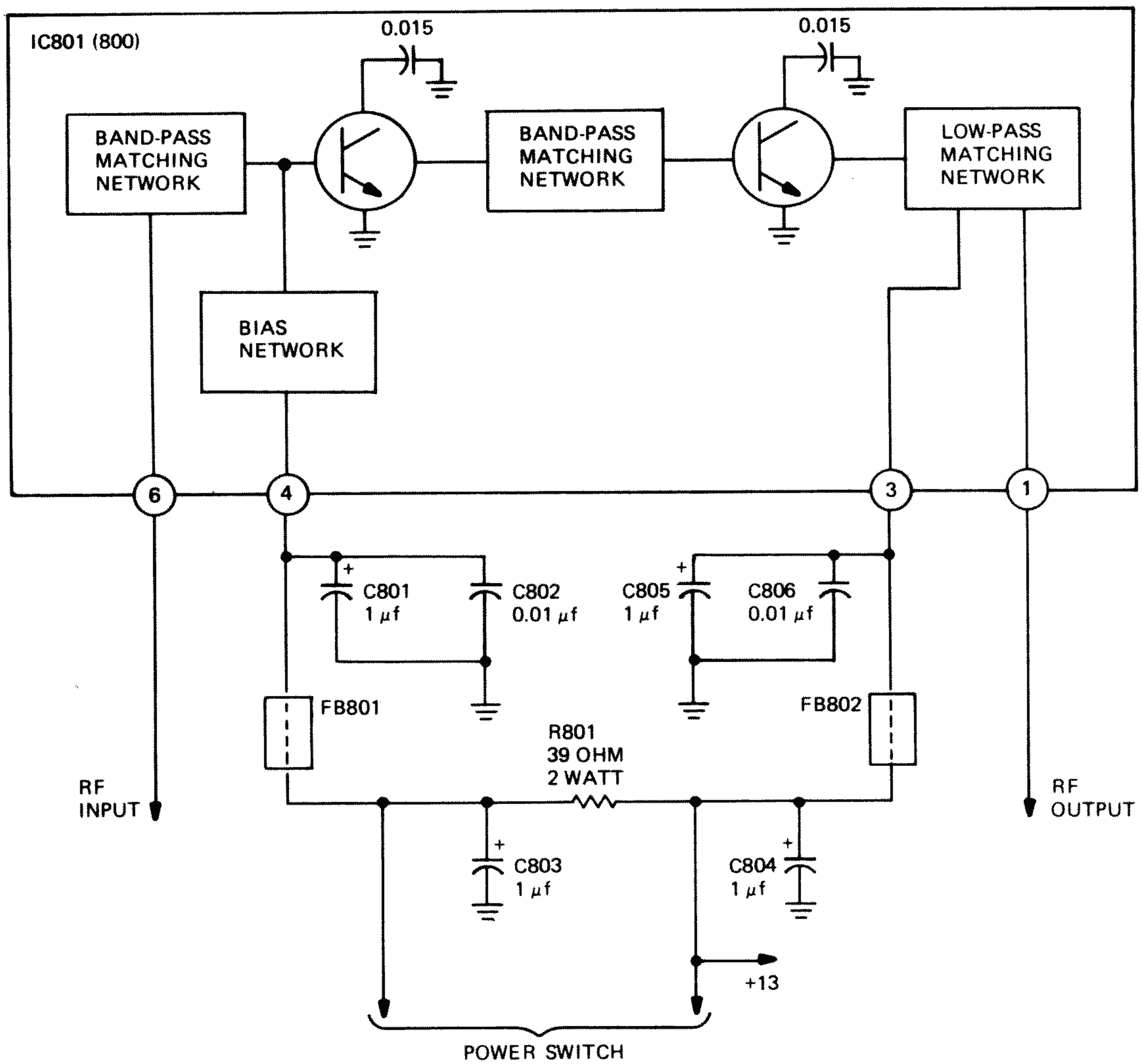

Fig. 29. Power amplifier schematic.

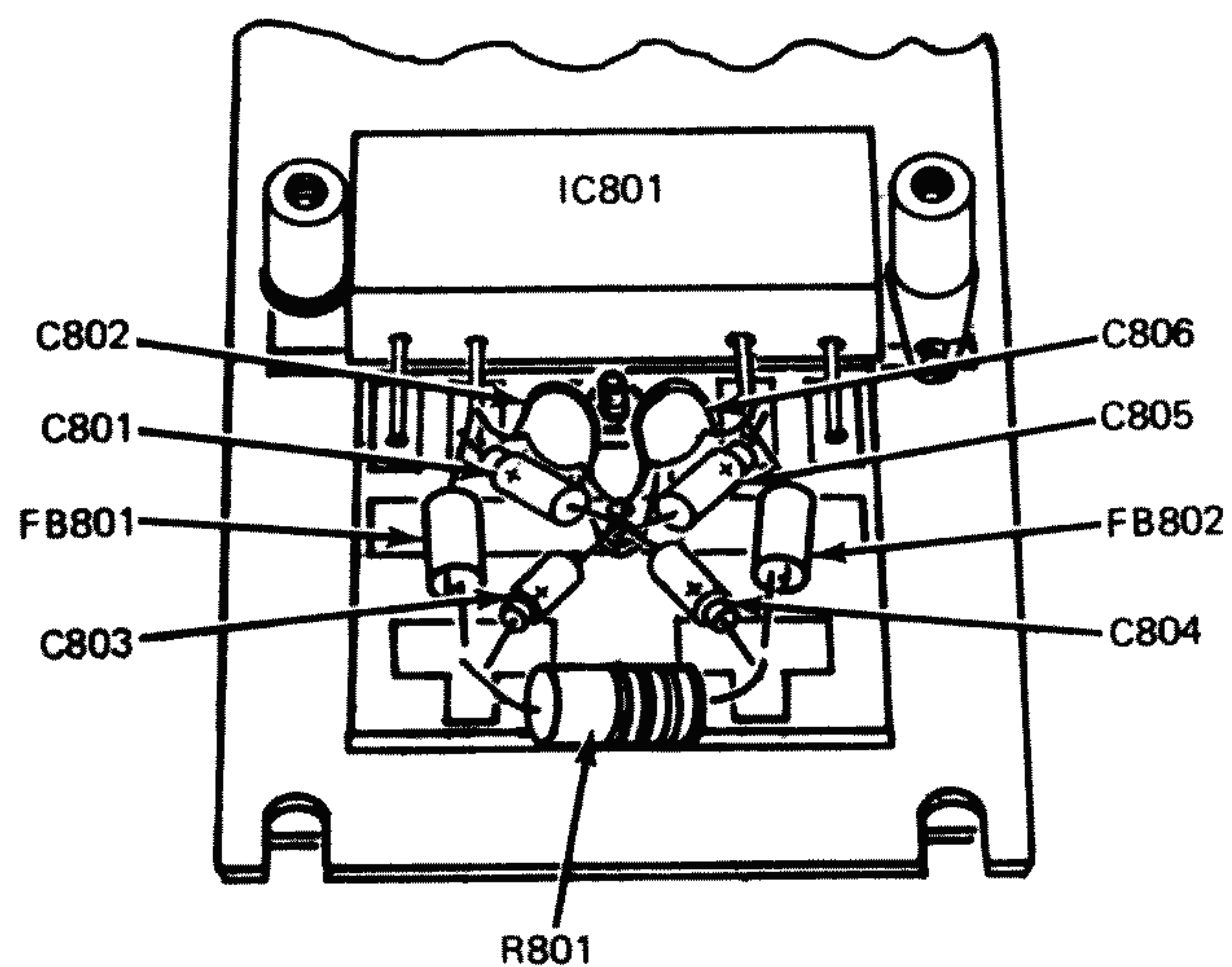

Fig. 30. Miscellaneous parts identification on the power amplifier circuit board.

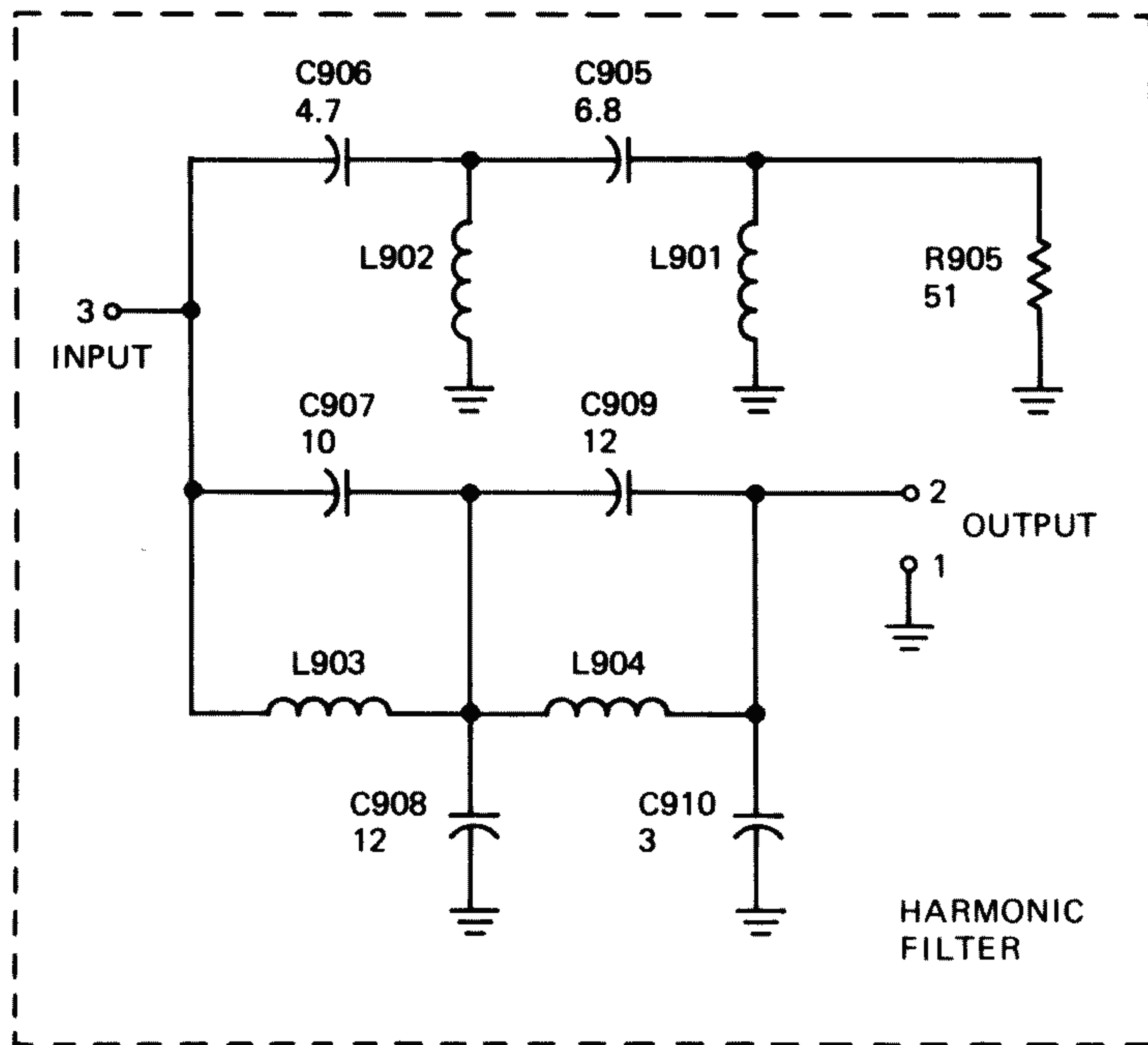

Fig. 31. Overall schematic diagram of harmonic filter.

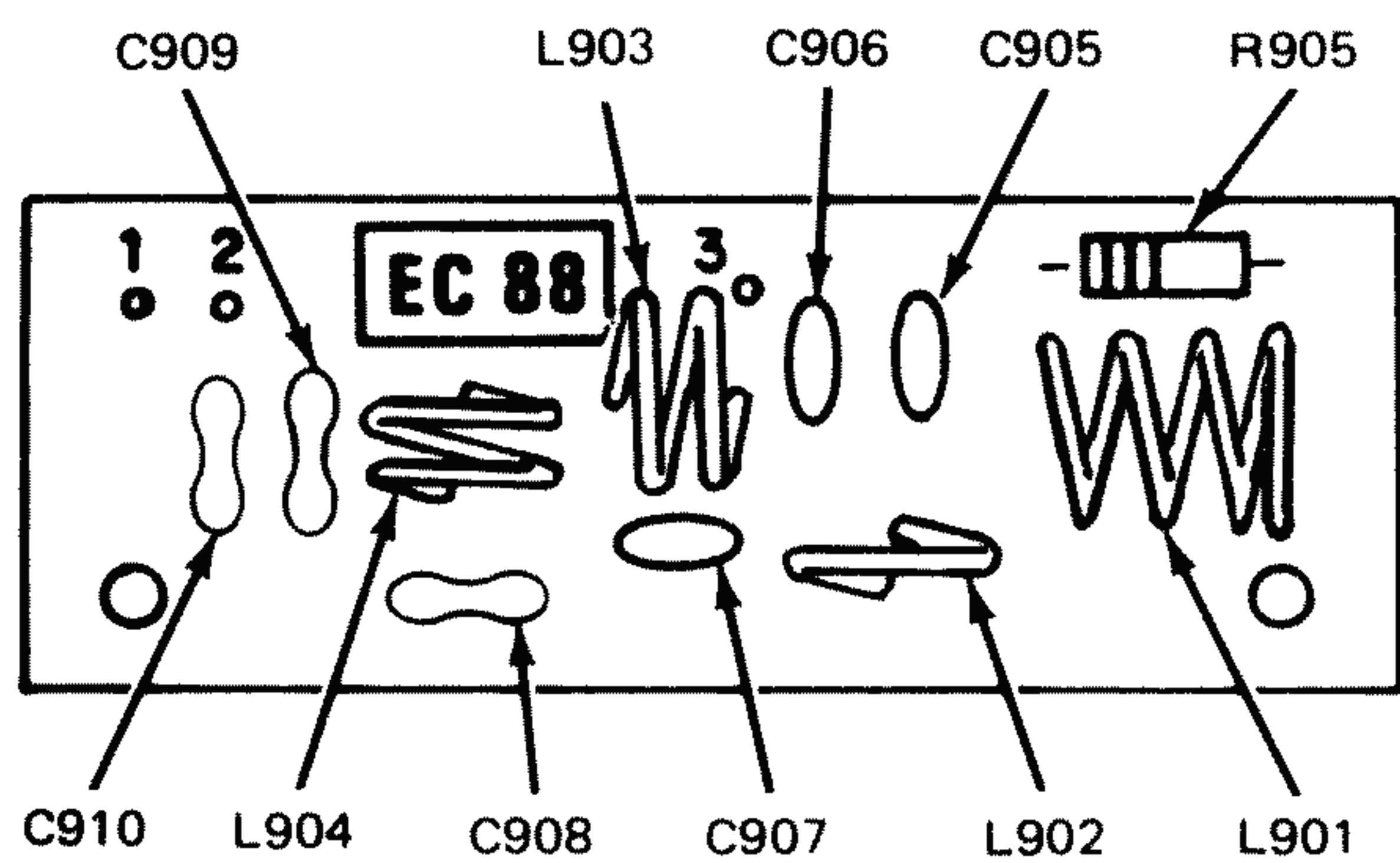

Fig. 32. Parts identification on EC88.



Innovation in learning
by a McGraw-Hill
Continuing Education School

Nc
139-OM-315(911)