

INSTRUCTION MANUAL

R. L. DRAKE MODEL

2-NT

CW TRANSMITTER



PRICE OF INSTRUCTION MANUAL \$2.00

TABLE OF CONTENTS

<u>Section</u>	<u>Page</u>
1. INSTALLATION -----	1
1.1 Unpacking -----	1
1.2 Power Requirements-----	1
1.3 Location -----	1
1.4 Cabling -----	1
2. ANTENNAS -----	4
2.1 General -----	4
3. OPERATION -----	8
3.1 Tuning Procedure-----	8
3.2 Delay Control -----	10
3.3 STBY position of FUNCTION switch -----	10
3.4 SPOT position of FUNCTION switch -----	10
3.5 EXT switch -----	11
4. SPECIFICATIONS -----	12
4.1 Frequency Coverage -----	12
4.2 Characteristics-----	12
4.3 Accessories -----	13
5. THEORY OF OPERATION -----	14
5.1 Block Diagram -----	14
5.2 Crystal Oscillator-----	14
5.3 Driver Amplifier -----	14
5.4 Power Amplifier -----	14
5.5 TVI Filter -----	15
5.6 Keying and Relay Control -----	15
5.7 Relay K1 -----	16
5.8 Sidetone Oscillator -----	16
5.9 Muting -----	16

<u>Section</u>		<u>Page</u>
6.	SERVICE DATA -----	18
6.1	Tube Replacement-----	18
6.2	Resistance Measurements -----	18
6.3	Voltage Measurements -----	19
6.4	Alignment -----	19
6.5	Trouble Shooting -----	20

ILLUSTRATIONS

<u>Figure</u>		<u>Page</u>
1-1	Connecting the 2-NT to the 2-C Receiver and Speaker -----	2
1-2	Connecting the 2-NT to the R-4A Receiver and Speaker -----	2
1-3	Connecting the 2-NT to any Receiver and Speaker -----	3
2-1	Half-wave Dipole Antenna for 80 meter Novice Operation -----	7
2-2	Half-wave Dipole Antenna for 40 and 15 meter Novice Operation -----	7
3-1	Front Panel Controls -----	8
5-1	2-NT Transmitter Block Diagram -----	17
6-1	Top View 2-NT -----	21
6-2	Bottom View 2-NT -----	21
7-1	Schematic Diagram 2-NT Transmitter-----	22

TABLES

<u>Table</u>		<u>Page</u>
3-1	Crystal Selection Table -----	9
3-2	Novice Crystal Selection Table -----	9
4-1	Tubes, Semi-Conductors, Lamps and Fuses --	13
6-1	Resistance Chart-----	18
6-2	Voltage Chart -----	19

SECTION 1 INSTALLATION

1.1 UNPACKING

Carefully remove the 2-NT from the shipping carton. Inspect the 2-NT for any signs of shipping damage. If any damage is noted, save the shipping carton and packing material and notify the transportation company. Complete and mail the registration card.

1.2 POWER REQUIREMENTS

The 2-NT Transmitter operates from a 120 volt, 50/60 Hz source.

1.3 LOCATION

Care should be taken to insure adequate space around the 2-NT for air circulation. Do not lay books, paper, etc. on top of the 2-NT cabinet during operation. Do not stack other equipment on the 2-NT cabinet.

1.4 CABLING

Figures 1-1 and 1-2 show the 2-NT connected to 2 popular DRAKE receivers. The 2-NT will operate with other receivers when connected as shown in Figure 1-3.

The inter-connecting cables used are shielded audio cable with RCA phono connectors on each end. The cables can be 2 to 5 feet in length. The cables can be purchased at most radio supply stores or from the R. L. DRAKE COMPANY.

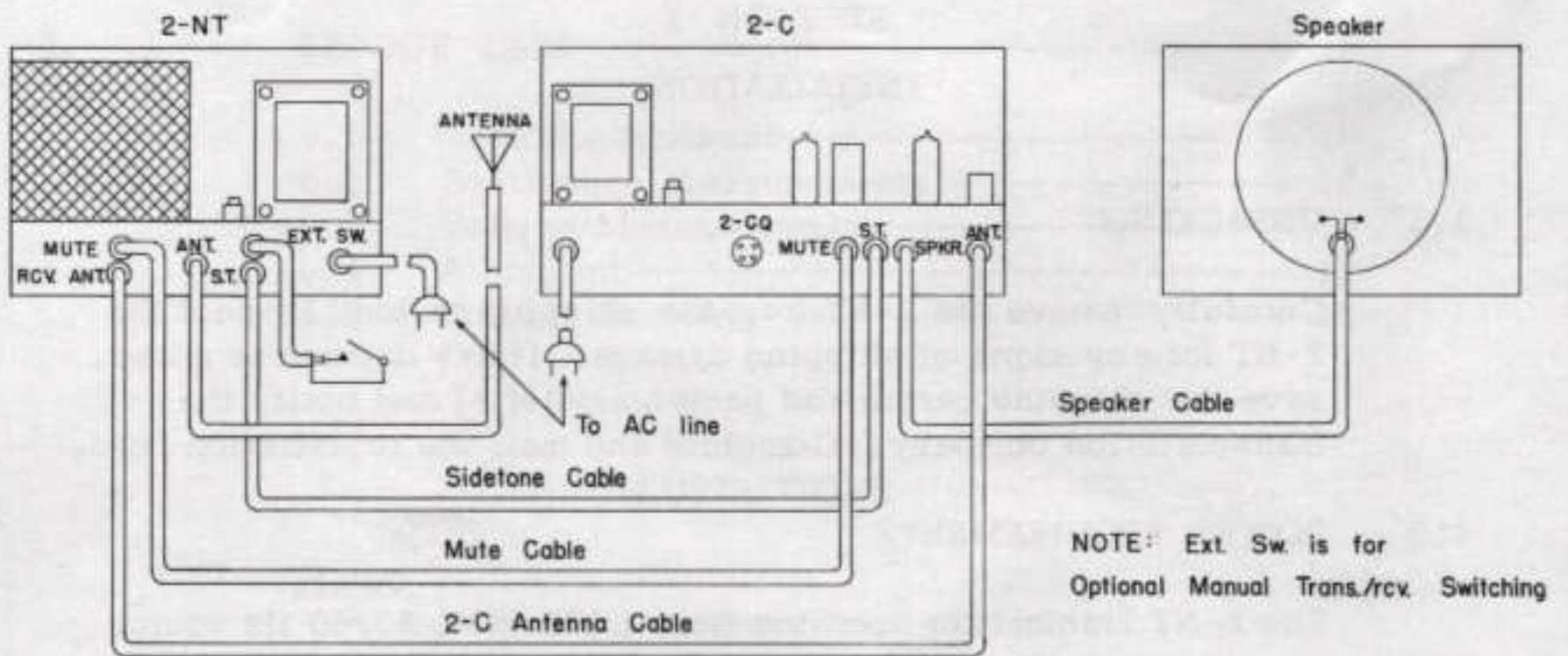

FIG. 1-1 CONNECTING THE 2-NT TO THE 2-C RECEIVER AND SPEAKER

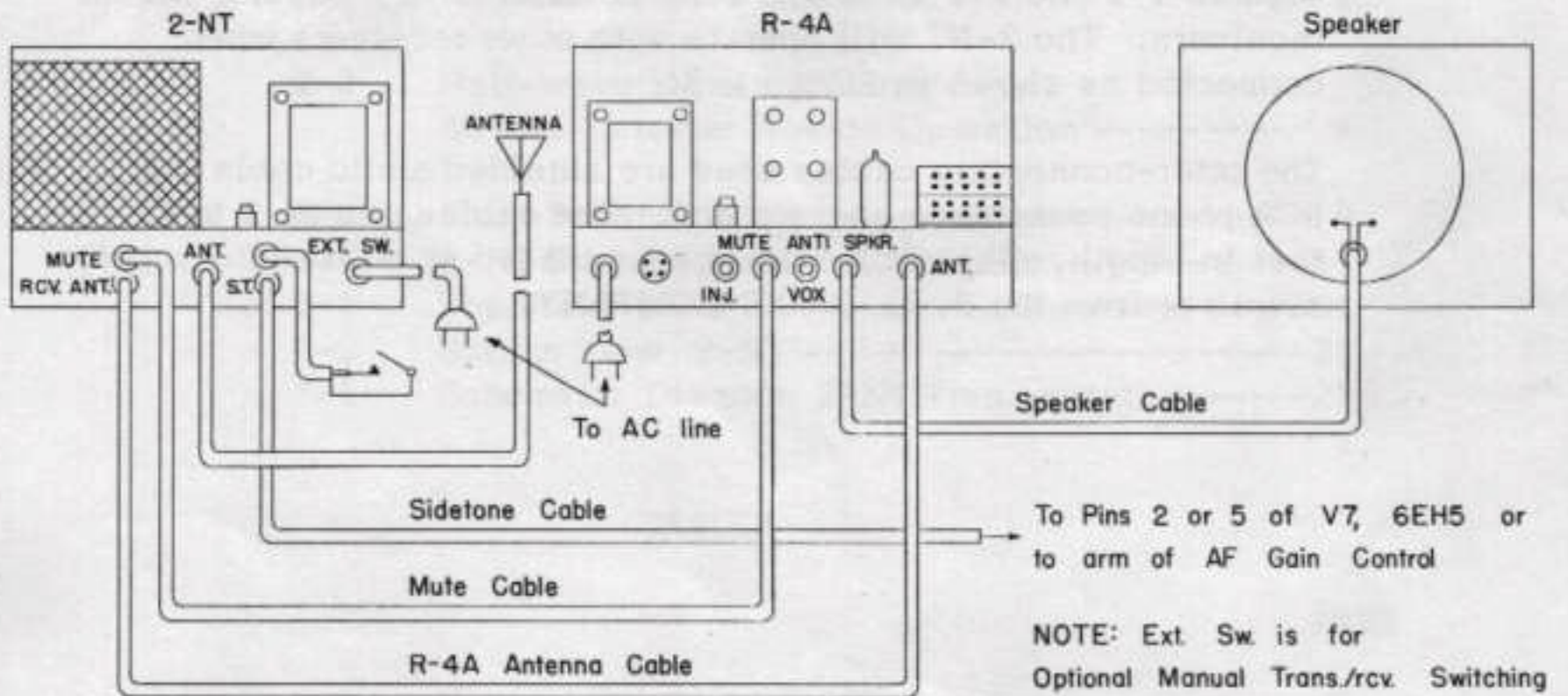

FIG. 1-2 CONNECTING THE 2-NT TO THE R-4A RECEIVER AND SPEAKER

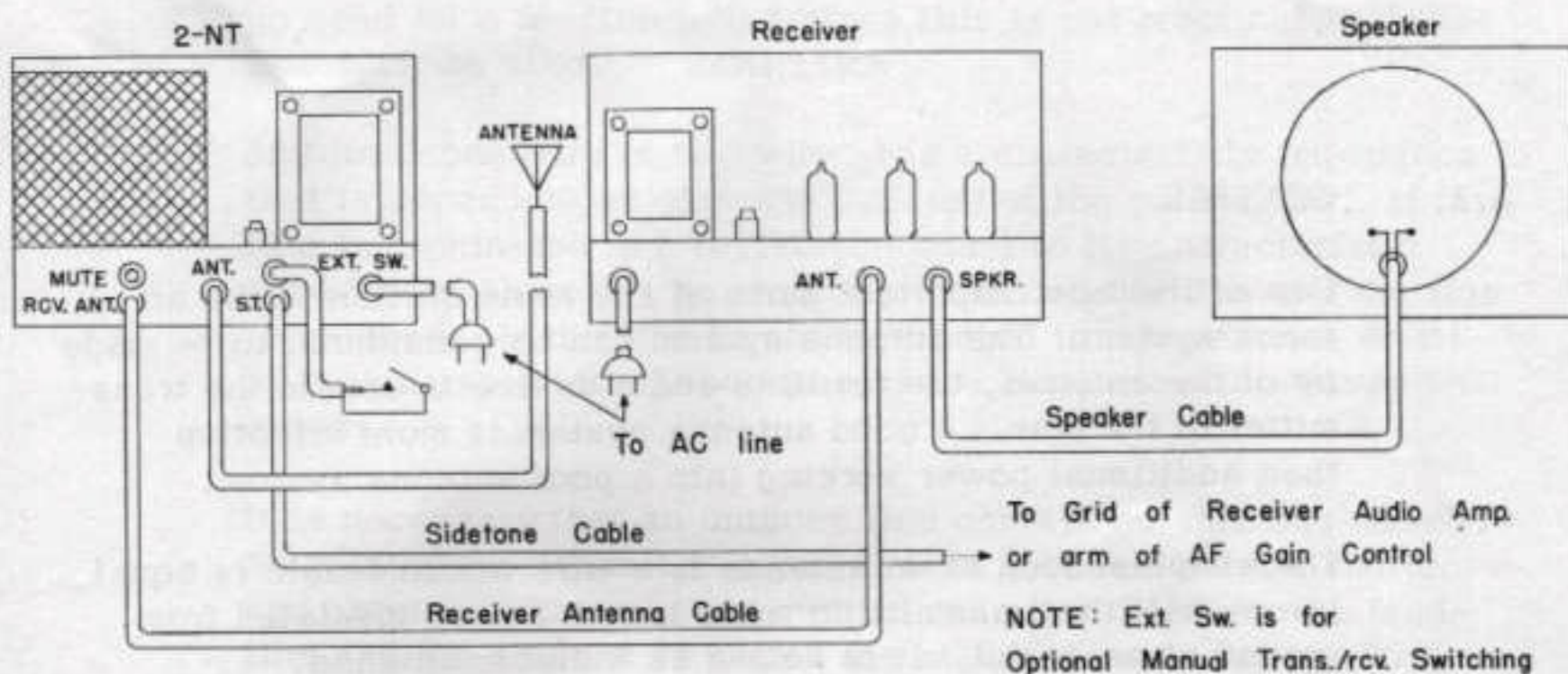

FIG. 1-3 CONNECTING THE 2-NT TO ANY RECEIVER AND SPEAKER

SECTION 2

ANTENNAS

2.1 GENERAL

One of the most important parts of any radio station is the antenna system. The antenna system can be considered to be made up of the antenna, the feedline and a device to couple the transmitter to the line. A good antenna system is more effective than additional power working into a poor antenna system.

The simplest form of an antenna is a wire whose length is equal to one half the transmitting wave length and is insulated from ground at each end. It is known as a dipole antenna.

When power from a transmitter is fed to such an antenna, the current and voltage vary along the length of the antenna. The current is maximum near the center and nearly zero at the ends. The reverse is true of the voltage. Since the impedance of the antenna is equal to E/I , the lowest impedance is at the center where the current is maximum and the voltage minimum. Practically, this impedance is about 60 to 70 ohms. The impedance increases towards the ends of the antenna.

To achieve the impedance of 60 to 70 ohms, the antenna should be at least 35 feet above the ground. The diameter of the antenna has an effect upon its impedance. No. 14 wire or larger should be used. The impedance can be changed by the presence of conductors or dielectric materials in the field of the antenna. Therefore, the antenna should be located away from large metal buildings and large concentrations of power lines, trees, and should be supported with good insulators of glass or ceramic material.

The importance of antenna impedance is that most transmitters are designed to operate into an impedance of about 30 to 100 ohms. Usually the nominal impedance of the transmitter output is 50 ohms. Therefore, the antenna should present a resistive load of the value that the transmitter was designed to load into.

The second part of an antenna system is the feedline. The purpose of the feed system is to transport power from the transmitter to the antenna with a minimum loss of power. If the antenna

could be connected directly to the transmitter, there would be no need for a feedline. But since this is not practical, a feedline must be used.

Any line, one wire or two wire, has a characteristic impedance that is dependent on size and spacing of the conductors. If this line is terminated in a resistance equal to its characteristic impedance, there are no standing waves on the line and the line is untuned. If the line is not terminated in a resistance equal to the characteristic impedance of the line, standing waves will appear.

It is necessary that an untuned line contain no standing waves. Standing waves result in a power loss between the transmitter and antenna. The measurement of mismatch between the feedline and the antenna is called the standing-wave ratio. For example, if a 300 ohm line is terminated in a 50 or 1800 ohm resistance, the mismatch and the standing-wave ratio will be 6 to 1.

As stated previously, the simplest form of antenna is the one half wave dipole, with an impedance of about 60 to 70 ohms. Transmitters are usually designed to load into an impedance of 30 to 100 ohms. If this antenna and transmitter combination is fed with a 50 to 72 ohm cable, the standing-wave ratio should be low.

Practically it is not feasible to construct an antenna system that has no standing waves. However, if the antenna is high in the air, away from obstructions and its length carefully measured, the system should perform satisfactorily and have a SWR less than 2:1 over novice frequencies on any one band.

The formula for calculating the length of a half-wave antenna is

$$\text{Length of half-wave, in feet} = \frac{468}{\text{Frequency in MHz.}}$$

Shown in Figure 2-1 is a half-wave dipole antenna for the 80 meter novice band. The length measurements are made to the eye of the insulators with the wire stretched tight. Connections of the feedline to the antenna must be soldered. Wire size is #14 or larger.

Figure 2-2 shows a half-wave dipole for 40 meters novice operation. If this antenna length is calculated at the low end of the novice band, the antenna can be used on the 15 meter novice band because its length is three half-wave lengths.

For a more detailed discussion on antenna theory and construction, the user is referred to the Radio Amateurs Handbook and the A. R. R. L. Antenna Book.

There are commercial antennas available that should perform adequately with the 2-NT. Among these are verticals and multi-band trap antennas.

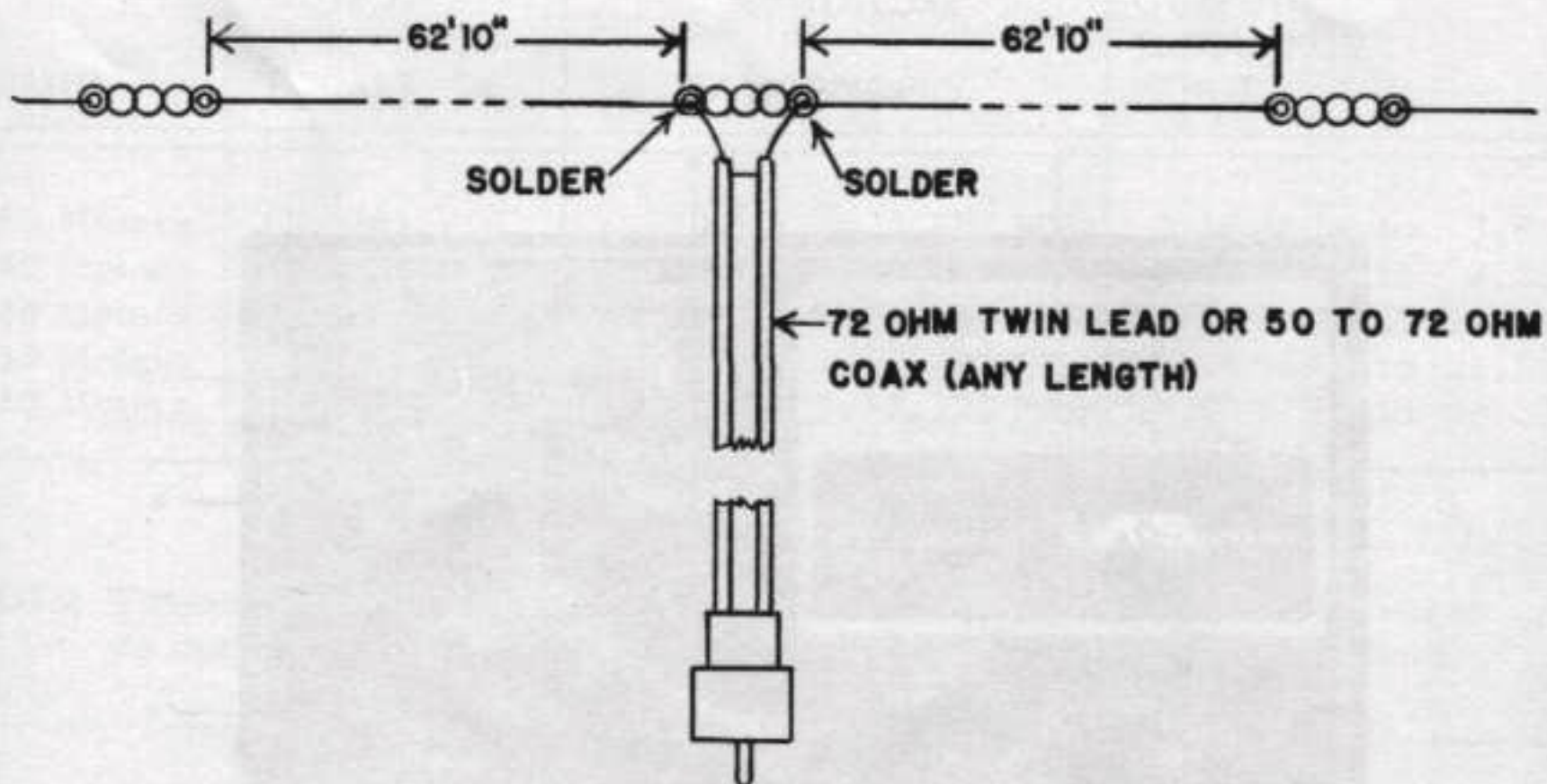

FIGURE 2-1

HALF-WAVE DIPOLE ANTENNA FOR 80 METER NOVICE OPERATION

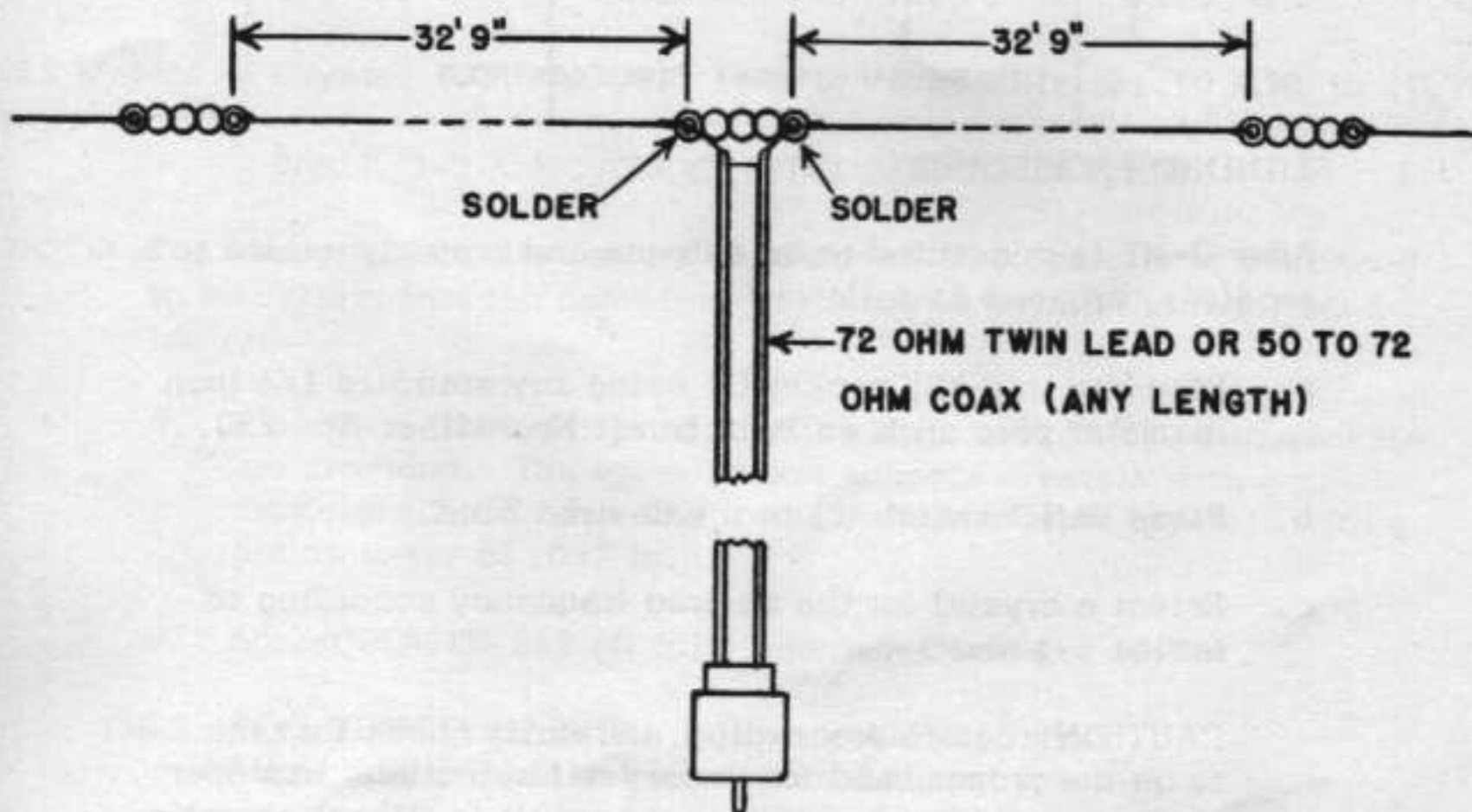

FIGURE 2-2

HALF-WAVE DIPOLE ANTENNA FOR 40 AND 15 METER NOVICE OPERATION

SECTION 3

OPERATION



FIGURE 3-1 FRONT PANEL CONTROLS

3.1 TUNING PROCEDURE

After 2-NT is connected to an antenna and properly cabled to a receiver, proceed as follows:

- a. Plug key into KEY socket (1) using any standard 1/4 inch diameter plug such as Switchcraft No. 420 or No. 220.
- b. Place BAND switch (2) in the desired band.
- c. Select a crystal for the desired frequency according to tables 3-1 and 3-2.

CAUTION: Before proceeding, carefully check that the 2-NT is on the proper band for the crystal selected. Improper setting of the Band switch could result in illegal operation. For example; If a 7.20 MHz crystal is used on the 15 meter Band position, the output frequency would be 21.60 MHz.

BAND	OUTPUT FREQUENCY EQUALS	CRYSTAL RANGE	OUTPUT FREQUENCY RANGE
80 Meters	Crystal x 1	3.50 MHz to 3.80 MHz	3.50 MHz to 3.80 MHz
40 Meters	Crystal x 1	7.00 MHz to 7.20 MHz	7.00 MHz to 7.20 MHz
20 Meters	Crystal x 2	7.00 MHz to 7.125 MHz	14.00 MHz to 14.25 MHz
15 Meters	Crystal x 3	7.00 MHz to 7.083 MHz	21.00 MHz to 21.25 MHz
10 Meters	Crystal x 4	7.00 MHz to 7.125 MHz	28.00 MHz to 28.50 MHz

TABLE 3-1 CRYSTAL SELECTION TABLE

NOTE: The above table calls out the band ends. The operator is cautioned to be certain that the operating frequency is within the legal band limits.

BAND	OUTPUT FREQUENCY EQUALS	CRYSTAL RANGE	OUTPUT FREQUENCY RANGE
80 Meters	Crystal x 1	3.700 MHz to 3.750 MHz	3.70 MHz to 3.75 MHz
40 Meters	Crystal x 1	7.150 MHz to 7.200 MHz	7.15 MHz to 7.20 MHz
15 Meters	Crystal x 3	7.033 MHz to 7.083 MHz	21.10 MHz to 21.25 MHz

TABLE 3-2 NOVICE CRYSTAL SELECTION TABLE

NOTE: The above table calls out the band ends. The operator is cautioned to be certain that the operating frequency is within the legal band limits.

- d. Plug the selected crystal into the XTAL socket (3). Two sockets are provided. The upper socket accepts crystals with a pin diameter of .050 in. The lower socket accepts crystals with a pin diameter of .093 in.
- e. Adjust POWER SET (4) fully counter-clockwise (CCW).
- f. Turn FUNCTION switch (5) to the XMIT position. Allow approximately 1 minute for filament warm-up.
- g. Close the hand key. The plate current meter (6) should read up scale.
- h. With the key closed, turn the TUNE control (7) for a dip (minimum) in plate current as shown on the plate current meter.

- i. Advance the POWER SET control for desired power input.
NOTE: For novice operation, the plate current must not exceed 150 milliamperes (marked in red on the meter).
- j. The output indicator light (8) should glow showing that there is RF output.
- k. If it is not possible to obtain a plate current dip, or if the POWER SET control does not raise the plate current to the red line or more, carefully check the antenna for improper connections, bad solder joints and length.
- l. With the key closed, adjust the SIDETONE GAIN control (9) for desired level from the speaker.
- m. The 2-NT is now ready for transmitting.

3.2 DELAY control (10)

This control is used to adjust the delay time between "key-up" and "receiver-on". In the extreme counter-clockwise (CCW) position, the transmit-receive relay follows the closing and opening of the hand key. Full break-in CW can be obtained with this setting. In the extreme clockwise position, delay of approximately 5 seconds can be obtained.

3.3 STBY position of FUNCTION switch

With the switch in this position, the 2-NT can be used as a code practice oscillator when connected to a receiver. The sidetone oscillator is keyed, but the power stages are not energized. It is not necessary to use a crystal in the STBY position.

3.4 SPOT position of FUNCTION switch

This position is used to tune the receiver to the transmitter output frequency. The frequency determining stages of the 2-NT are operating, but the power output stage is not.

- a. Place the BAND switch to the desired band.
- b. Plug the desired crystal into the proper XTAL socket.
- c. Place the FUNCTION switch in SPOT.
- d. Tune the receiver to the transmitter frequency as indicated by the tone heard in receiver.

NOTE: It is not necessary to close the hand key.

3.5 EXT switch

Manual control of the transmitter can be obtained by connecting a switch to the EXT. SW. connector on the rear chassis. When the switch is closed, the 2-NT is in the transmit mode and will be "on the air" when the key is closed. The switch can be a foot switch or a panel mounted toggle switch. Some receivers have a transmit/receive switch with the contacts brought out to a connector. The EXT. SW. can be connected to the available contacts.

SECTION 4

SPECIFICATIONS

4.1 FREQUENCY COVERAGE

The 2-NT provides crystal controlled operation in the CW portion of the 80, 40, 20, 15 and 10 meter amateur bands.

4.2 CHARACTERISTICS

- Input Power -----Variable to 100 watts.
(Plate current meter "red-lined" for 75 watts novice input power requirements.)
- Mode-----Break-in CW, Semi Break-in CW, or "Manual CW with DRAKE 2-C or other receivers.
- Automatic Transmit Switching-----Transmitter automatically "on the air" by closing the hand key.
- Antenna Change-over Relay-----Provides automatic antenna switching between transmit and receive. Mutes receiver while transmitting.
- Sidetone Oscillator ----- Provides monitoring of keying with any receiver.
- Frequency Spotting-----Enables receiver to tune to transmitted frequency without being "on the air".
- Simplified Tuning ----- Low level stages broadband. Pi-network output with fixed loading. PA plate tuning only.
- Low Pass Filter -----Prevents TVI by reducing harmonics in TV channels.

Power Requirements ----- 120 volts, 50 to 60 Hz at
approximately 2.8 amperes.

Dimensions-----9-7/8 inches wide.
6-9/32 inches high.
9-9/32 inches deep.

Weight----- 12-1/2 pounds.

4.3 ACCESSORIES

Antenna Matching Network
VFO
Crystals

SYMBOL	TYPE	FUNCTION
V1A	1/2 6EA8	Crystal Oscillator
V1B	1/2 6EA8	Relay Control
V2	12BY7	Driver Amplifier
V3	6HF5	Power Amplifier
Q1	2N3394	Sidetone Oscillator
D1, D2	1N483A	Pulse Forming
D3	1N483A	Oscillator Switch
D4	1N3194	Screen Rectifier
D5	1N3194	Bias Rectifier
D6, D7, D8, D9	1N3194	High Voltage Rectifier
DS1	47	Dial Lamp
DS2	NE2	RF Indicator
F1	5 amp, 120 V	Line Fuse

TABLE 4-1 TUBES, SEMI-CONDUCTORS, LAMPS AND FUSES

SECTION 5

THEORY OF OPERATION

5.1 BLOCK DIAGRAM

Figure 5-1 is a block diagram for the 2-NT Transmitter. The 2-NT is a crystal or VFO controlled transmitter, employing a crystal oscillator and two stages of amplification. Built-in features such as automatic antenna switching and sidetone are provided for ease of operation.

Figure 7-1 is a schematic diagram of the 2-NT Transmitter.

5.2 CRYSTAL OSCILLATOR

V1A, 1/2 of a 6EA8, operates as the crystal oscillator. The circuit operates as a modified Pierce Oscillator. On 80 and 40 meters, coil L3 provides a load impedance at the crystal frequency. On 20 and 10 meters, coil L1 and capacitor C7 tune the plate circuit to the second harmonic of the crystal frequency. On 15 meters, coil L2 tunes the plate circuit to the third harmonic of the crystal frequency. The output of the crystal oscillator is coupled to the grid of the driver amplifier by C10.

5.3 DRIVER AMPLIFIER

The driver amplifier, V2, uses a 12BY7 as the first stage of amplification. The stage is running as a Class C amplifier. Current limiting bias is provided by R7 and C12. The plate of the driver is broad band tuned on each band by switching in a tuned circuit on each band. 80, 40, 20 and 15 meters are tuned to the oscillator output frequency by L9, L8-C14, L6 and L5 respectively. On 10 meters coil L4 tunes the driver plate to twice the crystal oscillator output frequency. The stage is neutralized by capacitors C9 and C8. The output of the driver is coupled to the grid of the power amplifier by C15.

5.4 POWER AMPLIFIER

V3, 6HF5 operates as a Class C power amplifier. The grid of the tube is fixed biased at about 80 to 90 volts negative. Drive from the driver is sufficient to cause V3 to draw grid current. The output of the stage is tuned and loaded by a pi-network. The

input section of the pi is tuned by a 2 section variable capacitor C32 and C33. Capacitors C26, C28 and C30 are switched across the tuning capacitor to limit coverage to the different amateur bands. Coil L7 makes up the center section of the pi. The coil is taped and a different section of the coil is used for each band. The output section of the pi is made up of fixed loading capacitors C34, C35, C36 and C39. L18 is across the output section to keep B+ from the antenna in case of a short circuit in the plate coupling capacitor C24. The power of the Power Amplifier is adjusted by means of the POWER SET potentiometer R36. The control varies the screen voltage of V3.

Neutralization of the power amplifier is accomplished by C18 and C16.

5.5 TVI FILTER

The output of the power amplifier is fed through a low pass filter that attenuates harmonics that could possibly cause television interference. The signal is then fed to the antenna connector by relay K1.

5.6 KEYING AND RELAY CONTROL

Grid block keying is used to turn the driver, V2, on and off. A negative voltage of about 125 volts is applied to the grid of the driver through R6. This cuts off the driver tube. When the key is closed, the bottom of R6 is grounded removing the bias from the driver tube allowing it to conduct.

Clean, crisp and fast keying of the 2-NT is obtained by the action of the Pulse and Delay circuit in conjunction with the Relay Control stage V1B. With the key up, there is a high negative voltage on the anode of D2. There is a lower negative voltage on the anode of D1. Therefore, C41 is charged more negative on the D2 side. Capacitor C40 is negatively charged and applies about 15 volts bias to the grid of V1B, thus cutting the tube off.

When the key is closed, the anode of D2 is grounded. C41 discharges thru D1 applying a positive pulse to the grid of V1B. V1B conducts, energizing K1 rapidly. The negative charge on C40 is dissipated to ground through D2. The grid of V1B remains at essentially ground and the tube conducts as long as the key is down.

When the key is released, C4 charges through R9, the DELAY potentiometer, until the potential is great enough to cut V1B off. At this time C41 is again charged to deliver a positive pulse to activate the V1B the next time the key is closed.

5.7 RELAY K1

The contacts of relay K1 provide several functions. With the key up: the antenna is switched to the receiver, a ground is provided to the receiver mute line and the transmitter sidetone output line is opened. When the key is closed: the antenna is switched to the transmitter, the receiver mute line is opened, a ground is put on the oscillator cathode to turn the oscillator on and the sidetone output is switched to the sidetone jack.

5.8 SIDETONE OSCILLATOR

Transistor Q1, operates as a phase shift oscillator at a frequency of about 900 Hz. A phase shift of 180 degrees between the collector and base is obtained by 3 RC networks. C43 and R24 make up the first network. C44 and R25 make up the second, and C45 and the input impedance of the base make up the third network. R30, SIDETONE GAIN potentiometer is across the output and is used to adjust the sidetone level.

Diode D3 is used to turn the oscillator off and on. When the key is up, the diode has a negative voltage on its cathode allowing it to conduct. C42 then shorts the collector to base feedback to ground. When the key is closed, the cathode of D2 goes to ground and the diode does not conduct. Feedback from collector to base now occurs and the circuit oscillates.

5.9 MUTING

When the 2-NT Transmitter is keyed, the mute line is opened. When the key is up, the mute line is grounded. This system works with DRAKE receivers, but other receivers may not use the same system. Therefore, the Sidetone cable is used for both muting and sidetone output when used with a receiver other than a DRAKE. As shown by Figure 1-3, the Sidetone cable is connected to the grid of the receiver audio amplifier or the arm of the audio amplifier gain control. When the key is down, R21 is shunted across the audio tube grid. This resistor value is 1,000 ohms and should cut off the audio stage thereby muting the receiver. Sidetone output is obtained across the 1,000 ohm resistor.

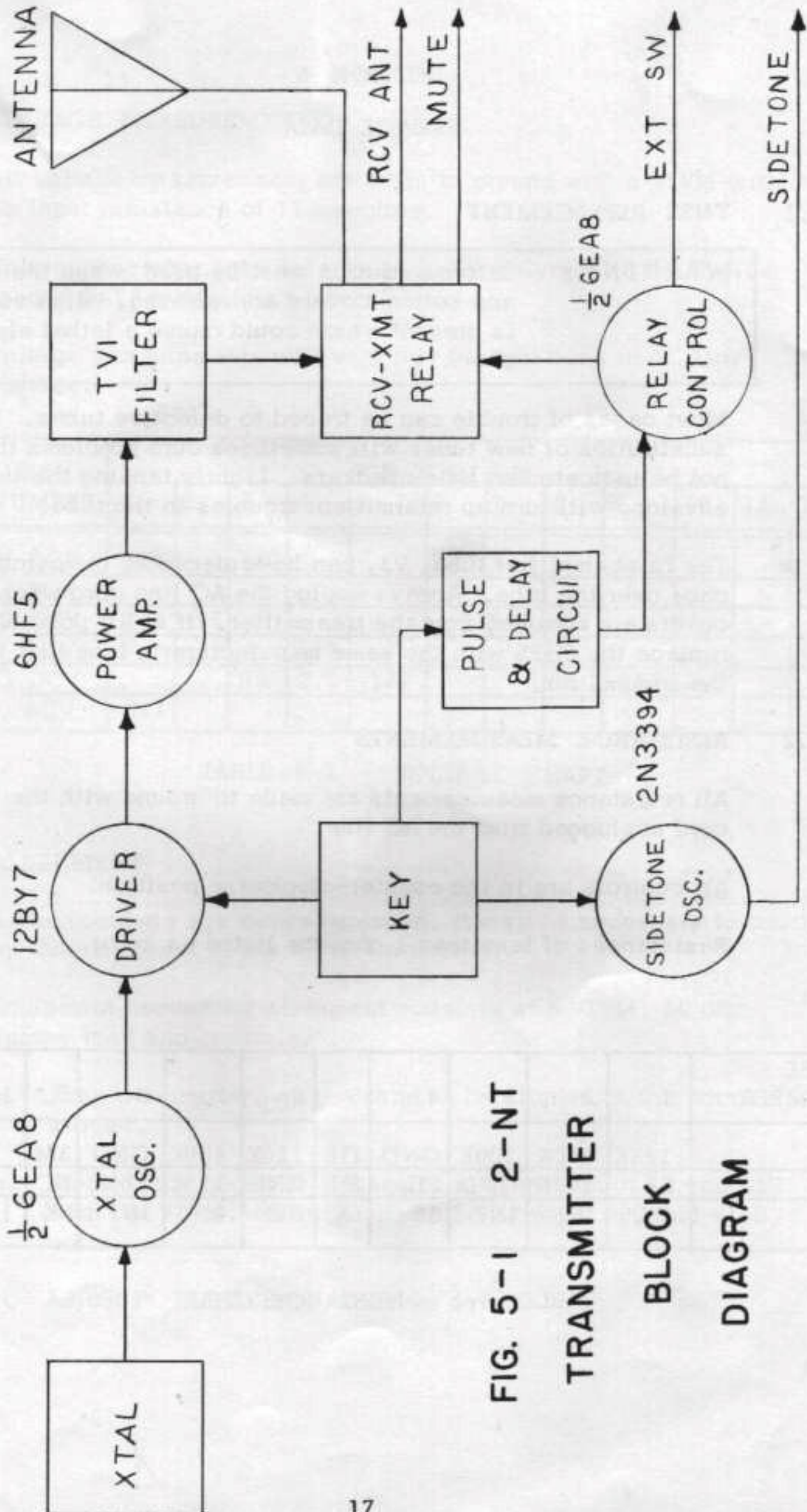

FIG. 5-1 2-NT
 TRANSMITTER
 BLOCK
 DIAGRAM

SECTION 6
SERVICE DATA

6.1 TUBE REPLACEMENT

WARNING: Extreme caution must be used when the top and bottom covers are removed. High voltage is present which could cause a lethal electrical shock!!

Most cases of trouble can be traced to defective tubes. Direct substitution of new tubes will sometimes cure problems that will not be indicated on tube checkers. Lightly tapping the tube envelope will turn up intermittent troubles in the tube.

The final amplifier tube, V3, can be replaced by removing the cage over the tube. Always unplug the AC line cord when the covers are removed from the transmitter. If at all possible, replace the 6HF5 with the same manufacturer's tube that is in the transmitter.

6.2 RESISTANCE MEASUREMENTS

All resistance measurements are made to ground with the line cord unplugged from the AC line.

All controls are in the counter-clockwise position.

Resistances of less than 1 ohm are listed as zero.

TUBE NUMBER	1	2	3	4	5	6	7	8	9	10	11	12
V1	125K	300K	200K	GND	FIL	120K	400K	GND	3M			
V2	68	150K	GND	FIL	FIL	GND	115K	120K	NC			
V3	FIL	NC	INF	15	6K	NC	0	INF	6K	15	NC	GND

TABLE 6-1 RESISTANCE CHART

6.3 VOLTAGE MEASUREMENTS

All voltage measurements are made to ground with a VTVM with an input resistance of 11 megohms.

Voltage measurements were made on 80 meters with the 2-NT loaded to 75 watts input power.

Voltage measurements will vary due to variations in AC line voltage.

TUBE NUMBER	PIN NUMBER											
	1	2	3	4	5	6	7	8	9	10	11	12
V1 DCV	140		140			240	8		-1.1			
ACV					6.3							
V2 DCV	1.2	-16					240	200				
ACV				6.3	6.3							
V3 DCV			95	2.5	-122			95	-122	2.5		
ACV	6.3											

TABLE 6-2 VOLTAGE CHART

6.4 ALIGNMENT

As components age or are replaced, it may be necessary to touch up the alignment of the 2-NT Transmitter.

Equipment needed for alignment consists of a VTVM, 50 ohm dummy load and crystals.

- a. Tune transmitter, on the band to be aligned, in the normal manner.
- b. Monitor the negative voltage at the junction of L9 and L10 with the VTVM. Voltage should be between -90 and -150 volts.
- c. Adjust POWER SET for maximum power.

- d. On 80 meters, use a 3.650 MHz crystal. On this band the crystal frequency should be within 25 KHz to insure proper power output at the band ends. Tune L8 for maximum negative voltage.
- e. On 40 meters, use a 7.10 MHz \pm 50 KHz crystal. Tune L7 for maximum negative voltage.
- f. On 20 meters, use a 7.10 MHz \pm 50 KHz crystal. Tune L6 for maximum negative voltage.
- g. On 15 meters, use a 7.053 MHz \pm 20 KHz crystal. Tune L5 and L2 for maximum negative voltage.
- h. On 10 meters, use a 7.053 MHz \pm 10 KHz crystal. Align L4 and L1 for maximum negative voltage.

6.5 TROUBLE SHOOTING

Most troubles that will arise in the 2-NT Transmitter can be cured by tube substitution or by alignment. If trouble does occur that cannot be corrected in this manner, return the unit to the dealer or write our Service Department describing the problem in detail.

Do not return the unit to the factory without prior authorization.

We will check and align your 2-NT for a nominal fee of Ten (\$10.00) Dollars plus transportation charges if the set has not been tampered with. If repairs are necessary, an additional charge will be made. Units that have been tampered with or misaligned will be repaired on a time and material basis only.

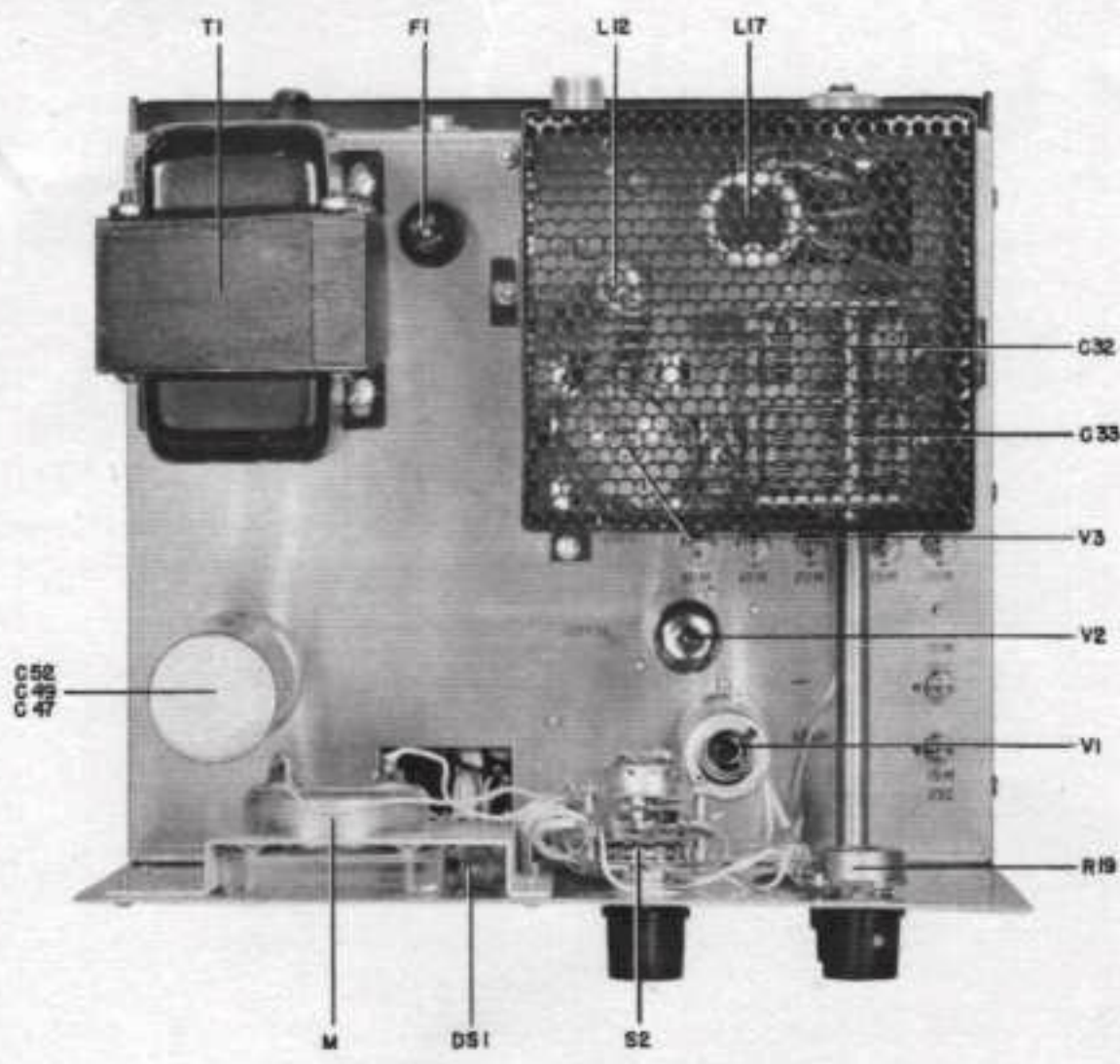

FIGURE 6-1 TOP VIEW 2-NT

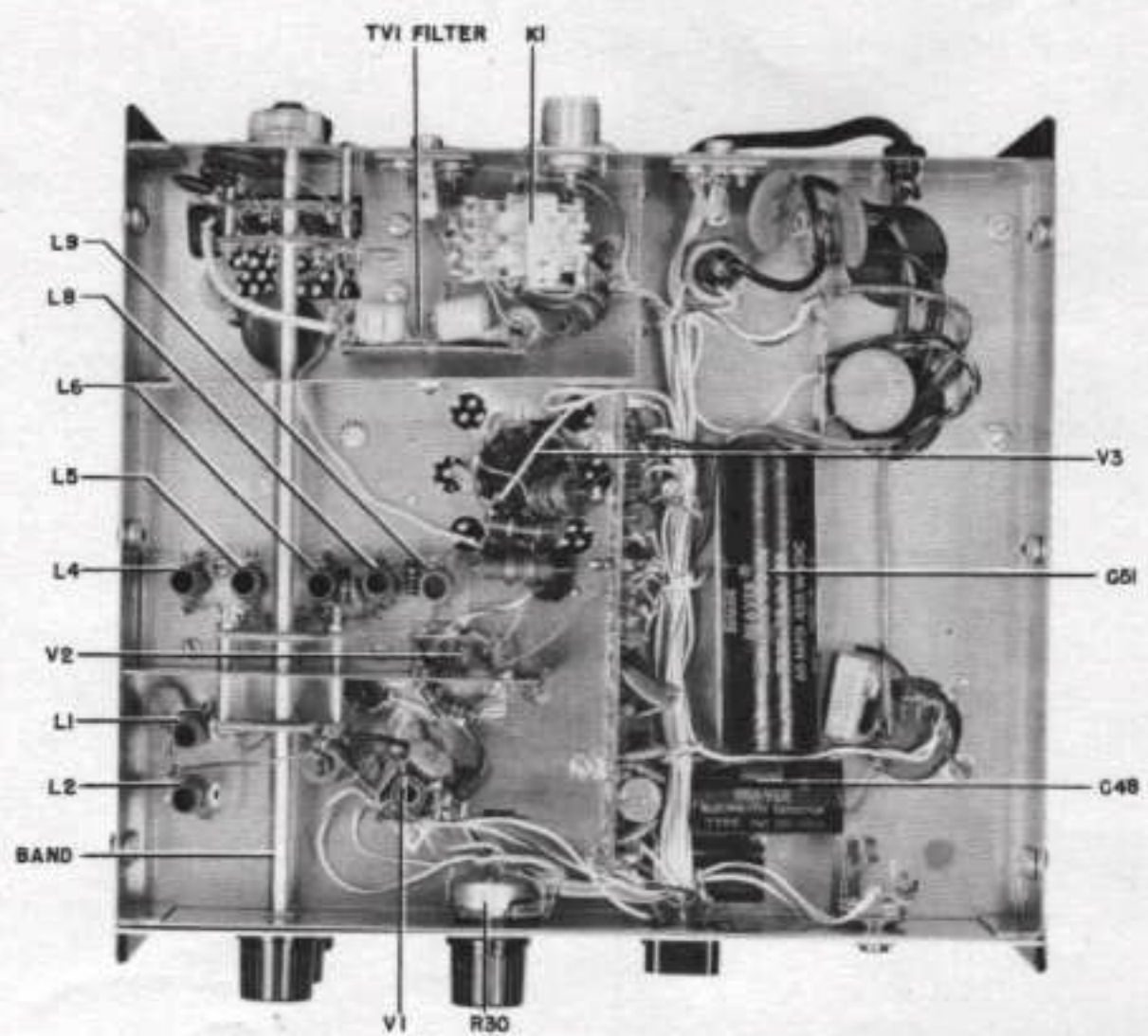

FIGURE 6-2 BOTTOM VIEW 2-NT

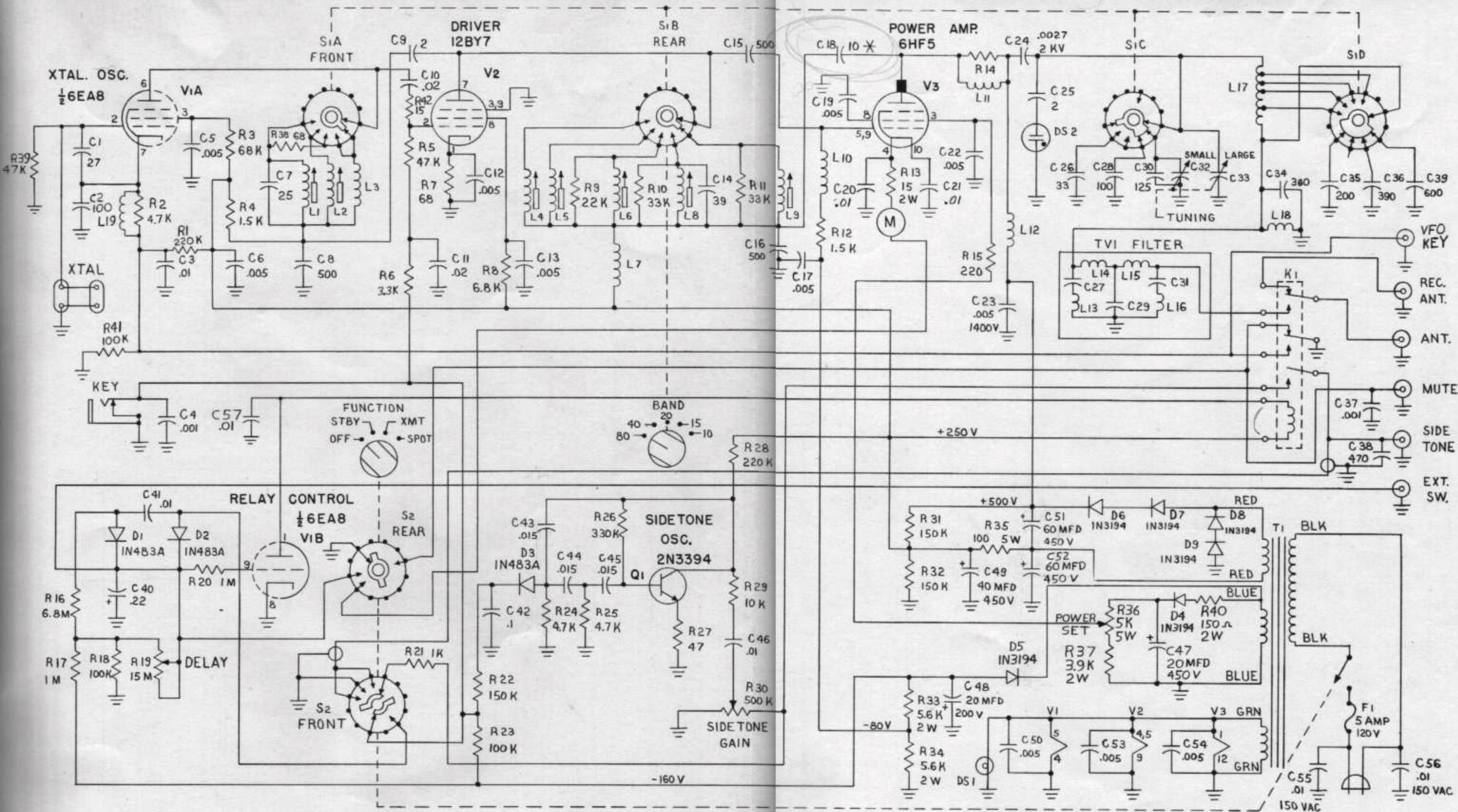

FIGURE 7-1
SCHEMATIC DIAGRAM MODEL 2-NT TRANSMITTER

NOTES: Capacitors marked 1.0 to 3000 are in pf and capacitors from .001 to .47 are in uf unless otherwise noted.

*10 pf for GE 6HF5
6 pf for Sylvania 6HF5

100166 0006

All resistors are 1/2 watt 10% unless otherwise noted. All switches viewed from front in counterclockwise position. Highest resistor R42. Highest capacitor C57