



TR270 FM Transceiver

Owner's Manual



Downloaded by

Amateur Radio Directory

DRAKE® is a registered trademark of the R. L. Drake Company

WARNING: TO PREVENT FIRE OR ELECTRICAL SHOCK DO NOT EXPOSE TO RAIN OR MOISTURE

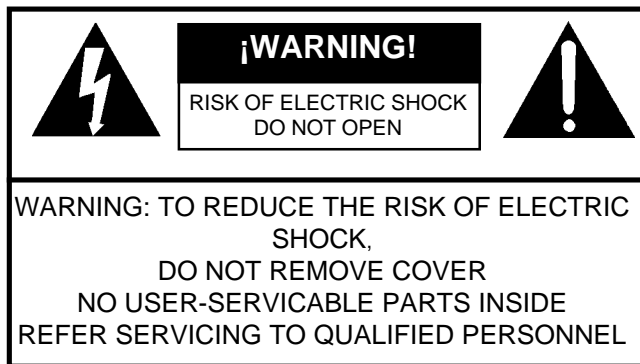

An appliance and cart combination should be moved with care. Quick stops, excessive force and uneven surfaces may cause the appliance and cart combination to overturn.

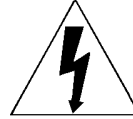

The lightning flash with arrow head symbol, within an equilateral triangle, is intended to alert the user to the presence of uninsulated "dangerous voltage" within the product's enclosure that may be of sufficient magnitude to constitute a risk of electric shock to persons.



The exclamation point within an equilateral triangle is intended to alert the user to the presence of important operating and maintenance (servicing) instructions in the literature accompanying the appliance.

WARNING: TO REDUCE THE RISK OF FIRE OR ELECTRIC SHOCK, DO NOT EXPOSE THIS APPLIANCE TO RAIN OR MOISTURE.
DO NOT OPEN THE CABINET, REFER SERVICING TO QUALIFIED PERSONNEL ONLY.

CAUTION: TO PREVENT ELECTRIC SHOCK, DO NOT USE THE THREE WIRE CORD WITH AN EXTENSION CORD RECEPTACLE OR OTHER OUTLET UNLESS THE BLADES CAN BE FULLY INSERTED TO PREVENT BLADE EXPOSURE.

ATTENTION: POUR PREVENIR LES CHOCS ELECTRIQUES, NE PAS UTILISER CETTE FICHE POLARISEE AVEC UN PROLONGATEUR, UNE PRISE DE COURANT OU UNE AUTRE SORTIE DE COURANT, SAUF SI LES LAMES PEUVENT ETRE INSEREES A FOND SANS EN LAISSER AUCUNE PARTIE A DECOUVERT.

1. Read Instructions—All the safety and operating instructions should be read before the appliance is operated.

2. Retain Instructions—The safety and operating instructions should be retained for future reference.

3. Heed Warnings—All warnings on the appliance should be adhered to.

4. Follow Instructions—All operating and use instructions should be followed.

5. Cleaning—Unplug this appliance from the wall outlet before cleaning. Do not use liquid cleaners or aerosol cleansers. Use a damp cloth for cleaning.

6. Do Not Use Attachments—not recommended by the manufacturer or they may cause hazards.

7. Water and Moisture—Do not use this product near water—for example, near a bathtub, wash bowl, kitchen sink, laundry tub, in a wet basement, or near a swimming pool—and the like.

8. Accessories—Do not place this product on an unstable cart, stand, tripod, bracket, or table. The product may fall, causing serious injury to a child or adult, and serious damage to the appliance.

9. Ventilation—This product should never be placed near or over a radiator or heat register. This product should not be placed in a built-in installation such as a bookcase or rack unless proper ventilation is provided or the manufacturer's instructions have been adhered to. Any slots or openings in the cabinet are provided for ventilation. To ensure reliable operation of the video product and to protect it from overheating, these openings must not be blocked or covered. The openings should never be blocked by placing the product on a bed, sofa, rug, or other similar surface.

10. Grounding or Polarization—This product is equipped with a 3-wire line cord receptacle. It is intended for use with a 3-wire properly grounded power socket. Do not defeat the safety purpose of the supplied line cord and plug.

10A. Mise à la terre ou Polarisation—Cet appareil est équipé avec un cordon d'alimentation à trois fils. Il est à brancher sur une prise ayant un connecteur à la terre. Assurez-vous que la connection à la terre ne manque pas.

11. Power Sources—This product should be operated only from the type of power source indicated on the marking label. If you are not sure of the type of power supplied to your home, consult your appliance dealer or local power company.

12. Power-cord Protection—Power-supply cords should be routed so they are not likely to be walked on or pinched by items placed upon or against them. Pay particular attention to cords at plugs, convenience receptacles, and the point where they exit from the appliance.

13. Lightning—For added protection for this product during a lightning storm, or when it is left unattended and unused for long periods of time, unplug it from the wall outlet.

14. Power Lines—An outside antenna system should not be located in the vicinity of overhead power lines, other electric light or power circuits, where it can fall into such power lines or circuits. When installing an outside antenna system, extreme care should be taken to keep from touching such power lines or circuits as contact with them may be fatal.

15. Overloading—Do not overload wall outlets and extension cords as this can result in a risk of fire or electric shock.

16. Object and Liquid Entry—Never push objects of any kind into this product through openings as they may touch dangerous voltage points or short-out parts that could result in a fire or electric shock. Never spill liquid of any kind on the product.

17. Servicing—Do not attempt to service this product yourself as opening or removing covers may expose you to dangerous voltage or other hazards. Refer all servicing to qualified service personnel.

18. Damage Requiring Service—Unplug this product from the wall outlet and refer servicing to qualified service personnel under the following conditions:

- a. When the power-supply cord or plug is damaged.
- b. If liquid has been spilled, or objects have fallen into the product.
- c. If the product has been exposed to rain or water.
- d. If the product does not operate normally by following the operating instructions. Adjust only those controls that are covered by the operating instructions. An improper adjustment may result in damage and will often require extensive work by a qualified technician to restore the product to its normal operation.
- e. If the product has been dropped or the cabinet has been damaged.
- f. When the product exhibits a distinct change in performance—this indicates a need for service.

19. Replacement Parts—When replacement parts are required, be sure the service technician has used replacement parts specified by the manufacturer or have the same characteristics as the original parts. Unauthorized substitutes may result in fire, electric shock or other hazards.

20. Safety Check—Upon completion of any service or repairs to this product, ask the service technician to perform safety checks to determine that the product is in proper operating condition.

21. Outdoor Antenna Grounding—Before attempting to install this product, be sure the antenna or cable system is grounded so as to provide some protection against voltage surges and built-up static charges.

- a. Use No.10 AWG (5.3mm²) copper, No.8 AWG (8.4mm²) aluminum, No.17 AWG (1.0mm²) copper-clad steel or bronze wire or larger, as ground wire.
- b. Secure antenna lead-in and ground wires to house with stand-off insulators spaced from 4 feet (1.22m) to 6 feet (1.83m) apart.
- c. Mount antenna discharge unit as close as possible to where lead-in enters house.
- d. A driven rod may be used as the grounding electrode where other types of electrode systems do not exist. Refer to the National Electrical Code, ANSI/NFPA 70-1990for information.
- e. Use jumper wire not smaller than No.6 AWG (13.3mm²) copper or equivalent, when a separate antenna grounding electrode is used.

"INSTALL WIRING ACCORDING TO THE CANADIAN ELECTRICAL CODE"
 "EFFECTUER LE CABLAGE CONFORMEMENT AU CODE CANADIEN DE L' ELECTRICITE"

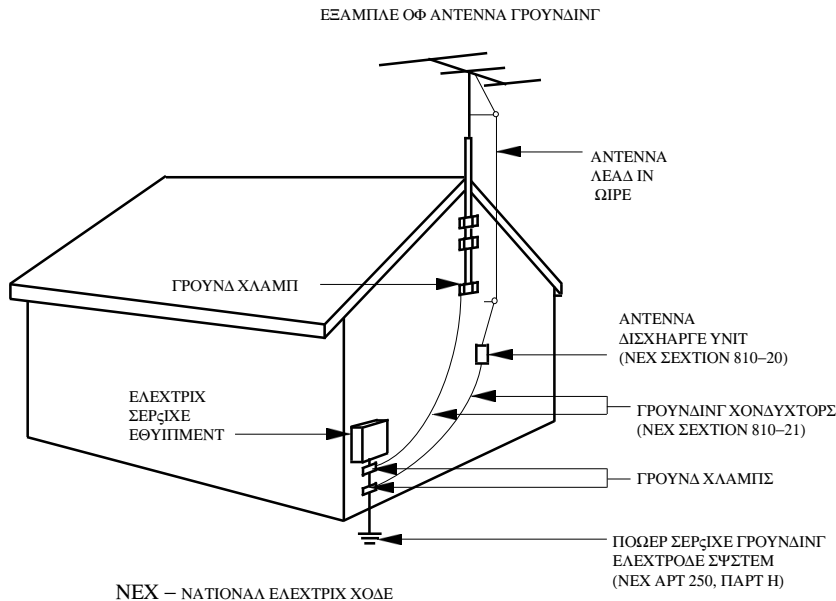

Thank you for purchasing a Drake TR270 FM Transceiver. This transceiver has been designed and manufactured to high quality standards, and will provide reliable operation for many years.

Please carefully read the Owner's Manual in order to take advantage of the many interesting features that will provide enjoyable radio operation.

Important Safeguards	i	Voice Operation	27
Table of Contents	iii	FM Simplex Operation	27
Specifications and Accessories	iv	Repeater Operation	27
Introduction	1	Standard Offsets	27
General Description	1	Custom Offsets	27
Safety / Voltage Selection	2	Subaudible Tone Operation	28
Installation	4	DTMF Operation	28
Unpacking	4	To store A Phone Number	29
Location	4	To Transmit A Stored Phone Number	29
Fixed Installation	4	Inband Repeat Operation	29
Portable / DC Power Installation	4	Crossband Repeat Operation	30
Antenna Requirements	4	Satellite Operation	31
Installation Diagram	5	Introduction To Satellite Operation	31
Front Panel Description	6	The Amateur Satellites-Modes and	
Microphone Connector Wiring Sense	7	Frequencies	33
Front Panel Display	8	Doppler Frequency Shift Correction	33
Rear Panel Description	10	FM voice Operation With A Satellite	33
Getting Started	12	9600 Baud Packet Operation	34
Beep Tones	12	With A Satellite	34
Getting Started (Initial Settings)	12	Computer Control	37
Dual VFO's	13	Computer Interface With The	
Direct Frequency Entry	13	RS-232C Port	38
Setup Menu	14	Command Set	38
Restore Factory Setup Settings	14	To Save A Report	40
Memory Functions	20	Data / FAX Operation	41
Memory Channel Programming	20	Data Operation With The Optional	
Recalling A Memory Channel	20	TNC 270 (Terminal Node Controller)	41
Changing Memory Channel	20	Fax Operation With The Optional	
Construct A Memeory List	20	DEMOM270	41
Locking A Memory Channel	21	Suggested References	42
Restore Factory Memory		Glossary of Terms	43
Programming	21	Quick Reference Guide	45
Scan Functions	22	Service	52
Scan Memory	23	Warranty	53
Scan VFO	25	FCC Warning	
Locking A Memory Channel	26	The user is cautioned that changes or modifications not expressly approved by the R. L. Drake company could void the user's authority to operate the equipment.	

FCC Warning

The user is cautioned that changes or modifications not expressly approved by the R. L. Drake company could void the user's authority to operate the equipment.

NOTE: In order for an installation of this product to maintain compliance with the limits for a Class B device, shielded cables must be used.



RECEIVER 'A' (2M only)

Receive Frequency Range:	144.00 - 148.00 MHz (142 - 150 MHz reduced specifications)*
IF Frequencies:	1st IF: 10.7 MHz 2nd IF: 455 kHz
Sensitivity:	<0.18 μ V, 12dB SINAD (144 - 148 MHz)
Selectivity:	12 kHz min. @ -6 dB
Adjacent Channel Rejection:	-75 dB min. @ \pm 20 kHz -80 dB min. @ \pm 25 kHz
IMD (in band) and Spurious Responses:	-80 dB min.
Squelch Sensitivity:	<0.10 μ V
IF Rejection:	-80 dB min.
Image Rejection:	-80 dB min.
Audio Power Output:	2W into 8 Ohms @ less than 5% distortion.

TRANSMITTER

Transmit Frequency Range:	144.00 - 148.00 MHz (142 - 150 MHz reduced specifications)*
Transmit Power Output:	1/10/25 Watts (144 to 148 MHz)
Modulation Mode:	16KF3E Frequency Modulation.
Deviation, max.:	5 kHz peak.
Spurious Emissions:	-60 dBc (-80 dBc in-band).
Microphone Impedance:	500 Ohms.
Protection:	Overtemperature and high VSWR.

GENERAL

Antenna 2 Preamp Power:	13.6 VDC nominal @ 100 mA
Packet Data Rate:	1200/9600 bps (G3RUH compatible)
Antenna Impedance:	50 Ohms
Memory Channels:	400 total: 100 (00-99) each receiver, A and B. 100 SAT mode 100 WXSAT mode
Tuning Steps:	5, 10, 12.5, 15, 20, 25 kHz, 1 MHz ( /  buttons only).
Frequency Stability:	\pm 5ppm (0°C to +40°C) \pm 10ppm (-10°C to +50°C)
Voltage Requirement:	115 or 230 VAC \pm 10%, 50/60 Hz, 75 Watts or 11 - 16 VDC, negative Ground.
Current Requirement, receive:	13.6 VDC @ 1.2A, nominal.
Current Requirement, transmit:	13.6 VDC @ 8A max. (high power RF output).
Operating Temperature:	-10°C to +50°C ambient.
Case Size:	Width 11", Height 4-3/4", Depth 13-1/2"
Weight:	13 lbs. (5.9 Kg.)

RECEIVER 'B' (wide coverage)

Receive Frequency Range:	136 - 174 MHz and 420 - 470 MHz
IF Frequencies:	1st IF: 18 MHz 2nd IF: 455 kHz
Sensitivity:	0.25 μ V/12 dB SINAD
Selectivity:	15 kHz or 40 kHz @ -6 dB, selectable.
Adjacent Channel Rejection:	-60 dB min. @ \pm 25 kHz, N BW -75 dB min. @ \pm 50 kHz, W BW or N BW
IMD: (in-band):	-75 dB min.
IF Rejection:	75 dB min.
Image Rejection:	60 dB min.

*142 - 150 MHz operation with proof of MARS or CAP license.

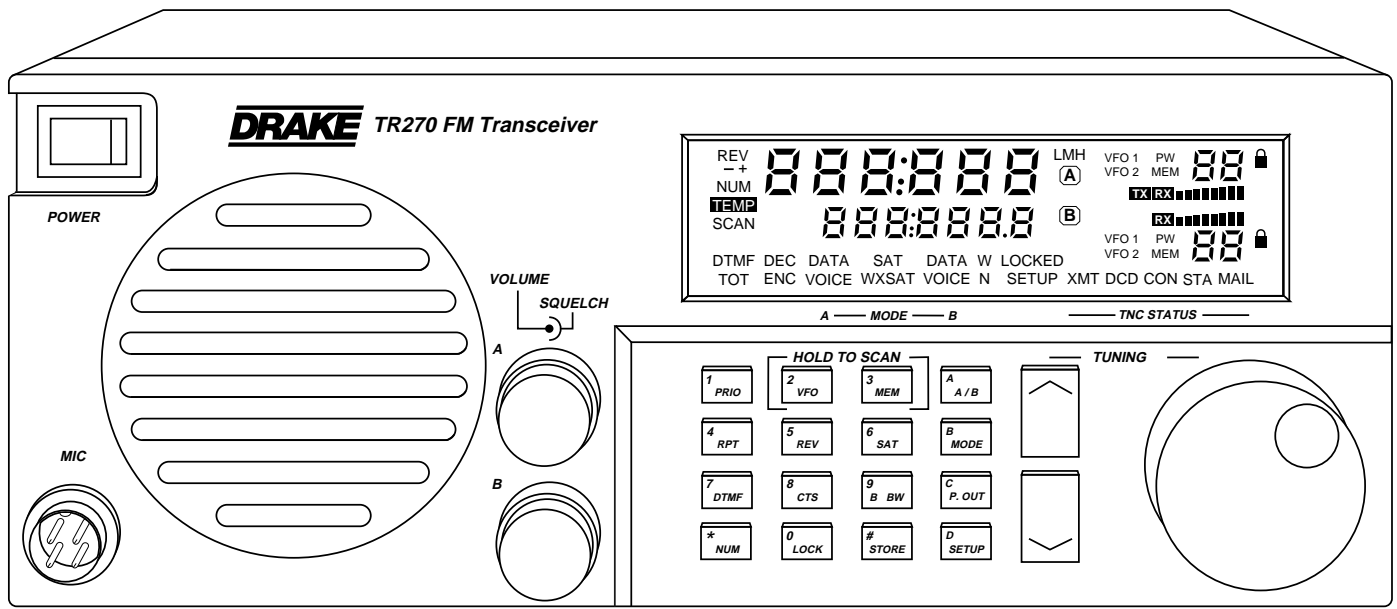

ACCESSORIES FOR THE TR270:

TNC270 module
DEM0D270 module
Carrying handle



DESCRIPTION

The TR270 is a table-top, base station, amateur radio 2 Meter FM Transceiver plus an additional extended range FM receiver. Microprocessor control and synthesized tuning permit full transceiver capability on transmitter/receiver 'A' from 144 to 148 MHz*, while receiver 'B' permits independent reception in the extended range of: 136 - 174 MHz, and 420 - 470 MHz. Transceiver 'A' is capable of 25 Watts RF output, with output power easily programmable from the front panel keypad for high, medium and low power output levels. Receiver 'B' is operational regardless of the receive/transmit status of transceiver 'A'. Independent Volume and Squelch controls are provided for both the 'A' and 'B' receivers. Control of either 'A' or 'B' is via the front panel keypad and frequency tuning is accomplished by the Tuning

wheel,  /  buttons, or by direct entry for the selected transceiver/receiver. Either receiver is capable of carrier detect or time scanning. Scanning can be by frequency limits or a memory scan. The TR270 has 400 programmable memory locations that are allocated as follows: 100 memories for Transceiver 'A', 100 memories for Receiver 'B', plus 100 additional memories assigned to 'WXSAT', and 100 memories for the 'SAT' (satellite) mode of operation. Both transceiver 'A' and receiver 'B' can operate simultaneously.

The front panel liquid crystal display provides visual feedback to the operator of the current status of the transceiver/receiver. Programming of the transceiver/receiver's parameters is easily accomplished by the front panel display and setup menu. Parameters are adjusted and set by using the tuning wheel and keypad.

The unit permits DTMF and CTCSS tone encoding/decoding of transceiver 'A'. A hand held microphone with push-to-talk feature is included with the TR270. DTMF functions can be initiated from the TR270 front panel keypad. Both receivers permit subaudible tone decoding and/or subaudible tone filtering.

In addition to normal voice FM communication, the TR270 provides interfaces for both an internal packet TNC and an external packet TNC. The optional, internal, plug-in Drake TNC270 permits more efficient setup and improved operation than an external TNC allows, since the compatible setup commands/protocols are designed into the TR270 for the internal TNC. The packet interfaces provide for 1200 bps or G3RUH compatible 9600 bps operation. Either receiver 'A' or 'B' can be switched to either TNC interface. An RS-232C port is provided for PC control of the TR270 and TNC270. PC software is provided with the DRAKE® TNC270 option.

The optional, DRAKE® DEMOD270, AM/FM, demodulator card, can also be installed to receive weather fax (WEFAX) data, ACARS (In Flight Aircraft Reporting Service) data, or HF FAX data. Weather satellite (WXSAT) reception in the 137 MHz band is also provided by the TR270 with the DEMOD270 installed. S-Band weather satellite reception is possible with the addition of an external downconverter prior to the TR270 with DEMOD270 combination. ACARS reception requires a receiver with aircraft band coverage. HF FAX reception requires a receiver with HF band SSB coverage. The demodulated audio data stream is supplied to the TR270 RS-232C Interface connector. PC software is provided with the Drake DEMOD270 option.

*142 - 150 MHz operation with proof of MARS or CAP license.

WARNING

NOTE: THE FOLLOWING PROCEDURE REQUIRES REMOVAL OF AN EQUIPMENT COVER THAT EXPOSES POTENTIALLY LETHAL VOLTAGES IF THE EQUIPMENT IS POWERED FROM AN AC POWER SOURCE. REFER SERVICING TO A QUALIFIED TECHNICIAN ONLY.

NOTE: A magnetized screwdriver facilitates the removal and installation of screws in the procedure that follows:

A) DISCONNECT THE TRANSCEIVER FROM ITS SOURCE OF AC POWER.

B) Remove the top cover from the transceiver by removing (6) Black screws, #6-32 x 1/4" PAN PHL. Retain the cover and screws for later reassembly.

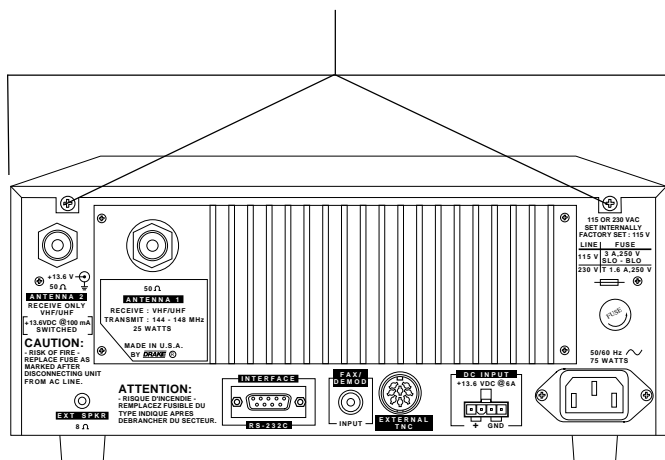

C) Locate the power supply cover. Remove the cover by removing (2) Screws, #4-40 x 1/4" PAN PHL Zinc from the left-hand side of the unit and by removing (2) Nuts, Hex #M3 x 6mm from the right-hand side of the compartment cover. Remove the cover by carefully releasing it from the exposed studs at the right-hand side of the cover. Retain the cover, screws, and nuts for later reassembly.

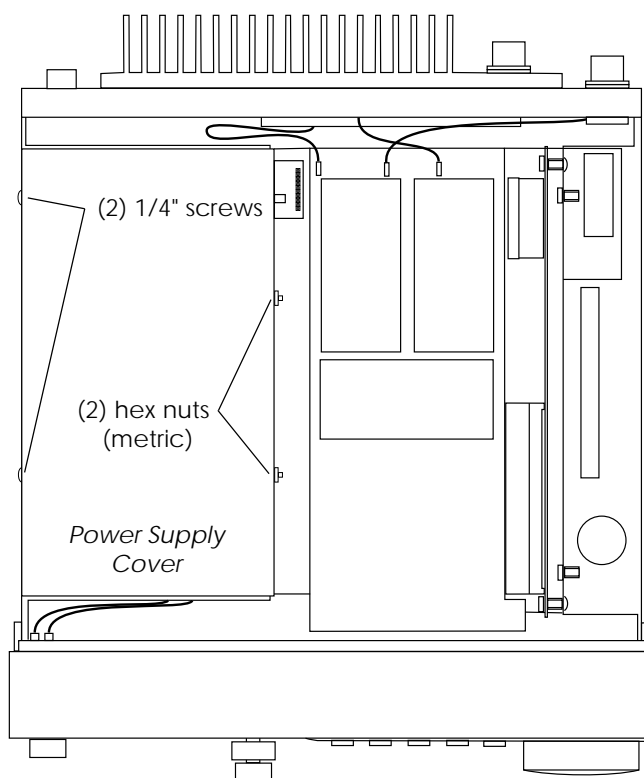

Downloaded by □

□

Amateur Radio Directory

WARNING!!!

Please read *before* applying power

The transceiver is normally shipped for operation on 115 VAC, 50/60 Hz AC input line voltage. If your operating voltage is different than this, please refer to FIGURE 1 on this page. An internal jumper permits changing the allowable AC input voltage to a nominal 230 VAC. In addition, the rear panel accessible mains fuse must change accordingly. Please be certain of the operating voltage before connecting the transceiver to the mains source.

Note: The warranty does not cover damage as a result of improper voltage selection, or replacement of the fuse with ratings other than those specified.

CAUTION

In accordance with international safety standards, this instrument is equipped with a three-wire power cable receptacle. The unit is shipped with a detachable type three-wire power cable intended for nominal 115 VAC mains supply. When connected to an appropriate power line outlet, this cable grounds the instrument cabinet. For operation of this unit on nominal 230 VAC mains supply, use the proper power cable assembly approved by your local codes. For use of this product outside the U. S. A. or Canada on supply voltages of 220 VAC or greater, the discharge resistor (4.7 Meg Ohm) connected from the neutral wire terminal of the AC input receptacle to the receiver chassis must be removed.

**WARNING**

NOTE: THE FOLLOWING PROCEDURE REQUIRES REMOVAL OF AN EQUIPMENT COVER THAT EXPOSES POTENTIALLY LETHAL VOLTAGES IF THE EQUIPMENT IS POWERED FROM AN AC POWER SOURCE. REFER SERVICING TO A QUALIFIED TECHNICIAN ONLY.

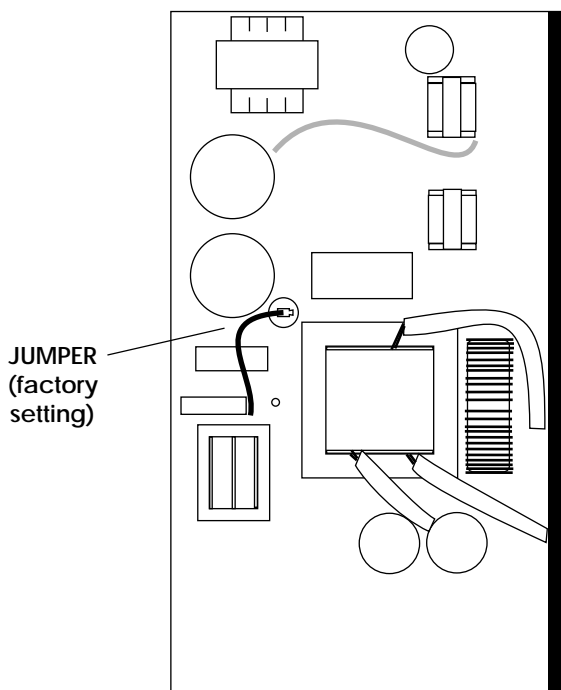

D) Ensure that the jumper is set for either the 115 VAC or the 230 VAC position as required for the AC Mains supply. Install the proper fuse at the rear panel of the TR270.

115 VAC

Fuse: 3A, 250V (5x20mm) SLO-BLO
(factory installed)

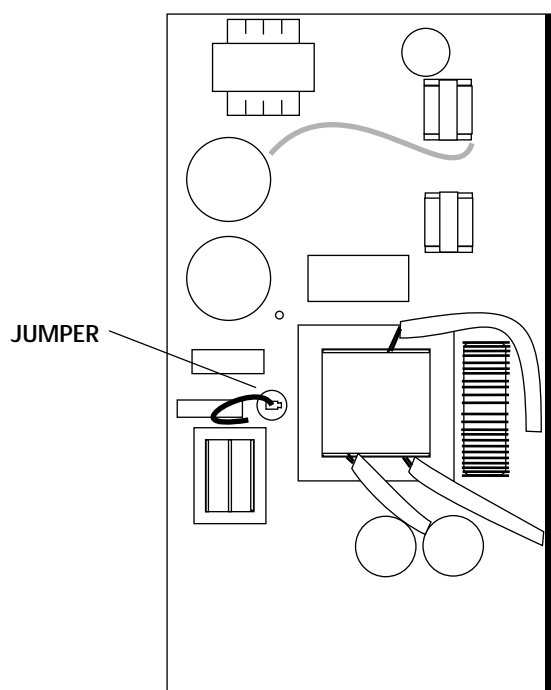
230 VAC

Fuse: T1.6A, 250V (5x20mm)

FIGURE 1 - AC Mains Voltage Selection

E) Reinstall the power supply compartment cover by using the cover, screws, and nuts removed in step C.

F) Reinstall the transceiver top cover using the (6) Black #6-32 x 1/4" screws PAN PHL that were removed in step B.

UNPACKING

Carefully remove the transceiver from the shipping carton and examine it for evidence of damage. If any damage is noted, immediately contact the transportation company responsible for delivery or return the unit to the dealer from whom it was purchased. Keep the shipping carton and all packing material for the transportation company to inspect. The original carton and packing material should be retained for repackaging should it be necessary to return the unit. Inspect the packing material for any accessories or printed material before storing the box. Locate the registration card, fill out, and immediately return to the R. L. Drake Company to insure registration and validation of warranty.

LOCATION

The location of the transceiver is not critical so long as adequate clearance is provided to allow air circulation in and around the unit, especially adjacent to the rear panel mounted heatsink. To prevent overheating, do not cover any ventilation slots in the top cover.

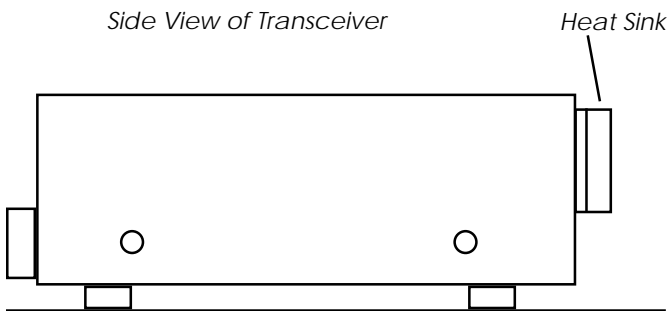

FIGURE 2 HEAT SINK

FIXED INSTALLATION

After unpacking the unit and checking that the intended AC line voltage matches the internally set range (factory set for 115 VAC) and corresponding fuse is installed, connect the antenna system to the appropriate antenna input(s). Connect AC cord to mains voltage. Connect any other external equipment at this time. Refer to Figure 3 for the diagram of a typical fixed installation.

PORTABLE/DC POWER INSTALLATION

For use in a portable environment, the transceiver includes an unfused external DC input connector. This connector is located on the rear panel. The transceiver will operate with a DC input voltage of 11-16 VDC. Full high power RF output during transmit is insured with a nominal supply voltage of 13.6 VDC or higher, as are supplied by typical automotive systems. The transceiver may be powered from the vehicle's cigarette lighter socket. An approved method is to make fused wire connections at the vehicle battery. Connect DC power observing correct polarity and fusing (10 A Fast Blow maximum) to avoid possible vehicle wiring damage and/or fire. Connect the antenna(s) to the appropriate antenna input(s) using 50 Ohm coax between the antenna and the transceiver.

ANTENNA REQUIREMENTS

The receiver incorporates internal switching to allow two separate antenna systems to be connected simultaneously. The unit will transmit out the ANTENNA 1 connector only, so a resonant 2-meter antenna must be connected to ANTENNA 1. A separate single-band or multiple-band antenna can also be connected to the ANTENNA 2 connector. By simple setup programming, either of the connected antennas can be split to either receiver 'A' or 'B' for the receive mode. Additional setup programming permits dedicated antenna usage or automatic antenna selection by corresponding band, VHF/UHF, or by frequency range. The typical antennas for use with this transceiver will include Verticals, Beam, or Ground Plane types with 50 Ohm coaxial cable feeds. The best antenna will depend upon the desired frequency coverage and the intended communication link distance.

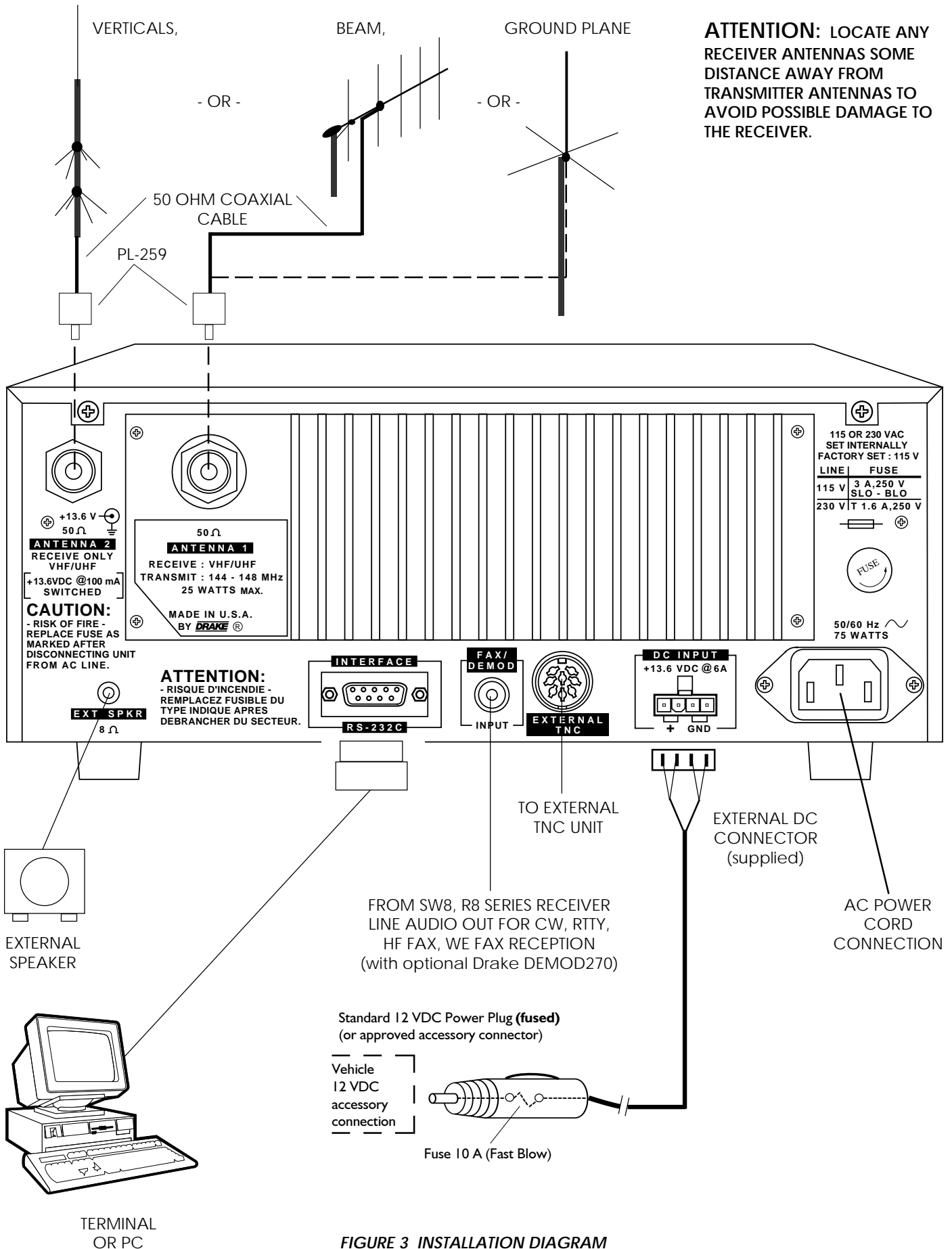

FIGURE 3 INSTALLATION DIAGRAM

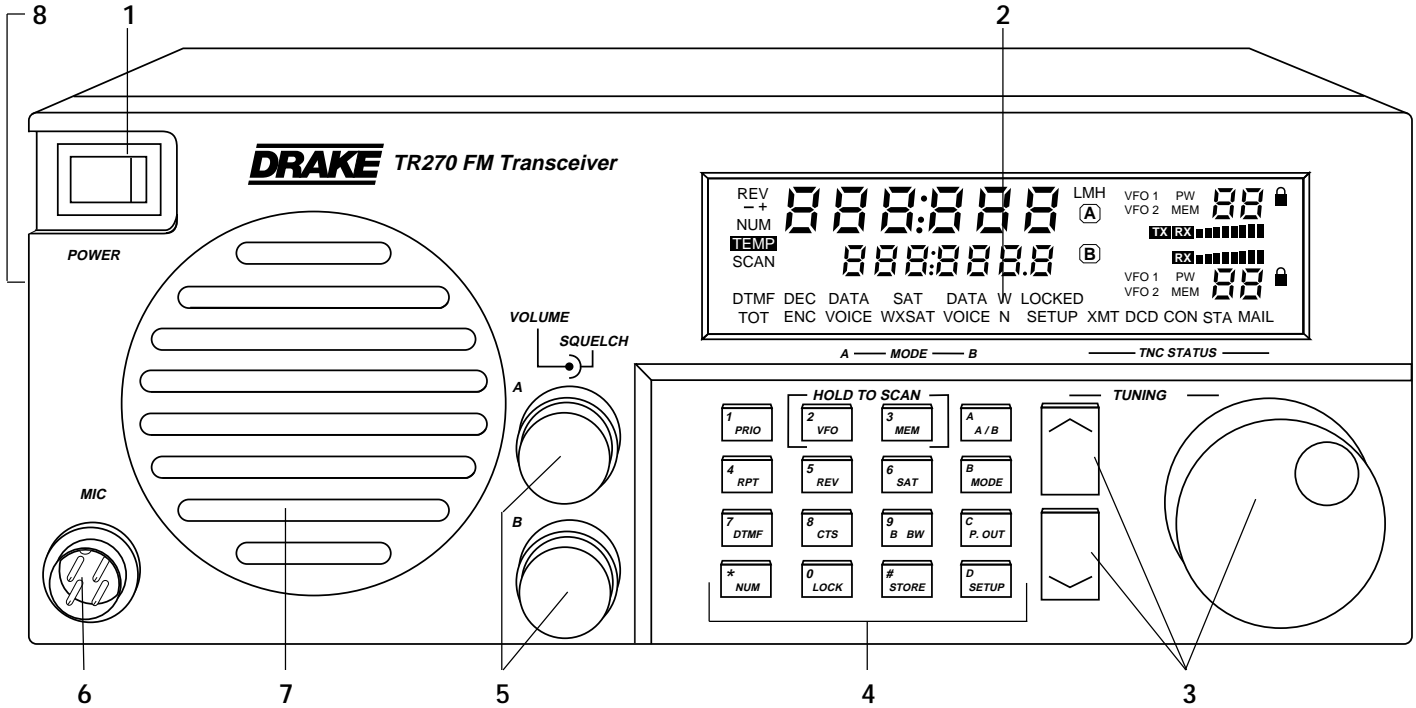
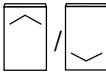
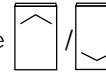



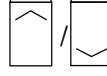

FIGURE 4 FRONT PANEL

1) POWER ON/OFF Switch - This switch turns the transceiver on or off. When the unit is off, the display will be blank. AC power is interrupted to the unit with the switch in the off position.

2) Display - The backlit, liquid-crystal display provides the current status of both receiver 'A' and 'B', such as operating frequency, received signal strength, relative transmit power, memory number, scan mode, simplex/duplex operation with repeater offset sense, TNC modes/setups, etc. Refer to FRONT PANEL DISPLAY, in this manual, for a full description.

3) TUNING (VFO) - The tuning wheel and the  buttons are the primary tuning controls of the transceiver. Clockwise rotation of the tuning wheel increases frequency and counterclockwise rotation decreases frequency. The tuning wheel also incorporates two-speed tuning. Rotating the tuning wheel faster results in an increased tuning speed. The transceiver also accepts direct numeric frequency entry from the numeric keypad buttons, see Item 4.

In the setup mode, the tuning wheel and the  buttons permit scrolling and selection of various transceiver parameters. The tuning wheel and  buttons are also used to scroll through memory channels in the memory mode of operation.



The  buttons also function to permit setting parameters in certain programming operations. The  buttons are the only auto-repeating buttons.

TUNING WHEEL STEPS

The transceiver can be programmed to tune in different resolutions (steps) with the corresponding display readout, as follows:

- Transceiver 'A': 5, 10, 15, 20, and 25 kHz steps.
- Receiver 'B': 5, 10, 12.5, 15, 20, and 25 kHz steps.



 **BUTTON STEPS**

The  button increases and the  button decreases the frequency by fixed 1 MHz steps with each depression of the button.

4) Program Buttons -

1 **PRIO** - Press once to switch the selected transceiver/receiver frequency to the programmed priority channel frequency. Press and hold for approximately 2 seconds to initiate the priority watch mode.

2 **VFO** - Press once to put the selected transceiver/receiver in the VFO tuning mode. For the selected transceiver/receiver, press this button to toggle between VFO1 and VFO2. Also, press and hold this button to initiate a VFO scan.

3 **MEM** - Press once to recall the current memory channel for the selected transceiver/receiver. Select memory channel by direct numeric entry or scroll through with tuning wheel or  /  buttons. Press and hold to initiate MEMORY channel scan.

4 **RPT** - Press to manually select the repeater offset direction or simplex.

5 **REV** - With the repeater status displayed, press this button to reverse the repeater input/output frequency format.

6 **SAT** - Press to automatically configure the transceiver for the satellite communication mode.

7 **DTMF** - Press to select a programmed phone number for dialing. Up to 10 phone numbers can be stored.

8 **CTS** *For Transceiver 'A'* - Press once to display the current CTCSS tone frequency. Press a second, third and fourth time before the display times out or within approximately 3 seconds to select 'ENC', 'DEC/ENC', or no tone on transmit or receive as required. The selected state will remain operational after the display times out.

For Receiver 'B' - Press once to display the current CTCSS tone frequency. Press a second and third time to enable or disable ('OFF') the tone decoding as required.

9 **B BW** - Press to select either 15 kHz or 40 kHz IF bandwidth for receiver 'B'. The 40 kHz bandwidth is normally used only for weather satellite FAX reception. NOTE: receiver 'A' bandwidth is not selectable.

***** **NUM** - Press for a second function keyshift. When pressed, the orange button functions are active, (i.e. 0-9, *, #, A, B, C, D).

0 **LOCK** - In the MEMORY mode, press this button to lockout the displayed memory channel during a memory scan. Otherwise, press and hold this button to lock/unlock all front panel buttons and tuning wheel entries.

**STORE** - Press to store selected entries when programming.

A **A/B** - Press this button to alternately direct the tuning and other keypad operations to the 'A' transceiver or 'B' receiver.

B **MODE** - For transceiver 'A', press to select VOICE or DATA (if TNC assigned to 'A') or STANDBY mode. For receiver 'B', press to select VOICE, DATA (if TNC assigned to 'B'), WXSAT or STANDBY mode.

C **P. OUT** - Press to set the relative transmit power output level to low, medium, or high power.

D **SETUP** - Press and hold for approximately 2 seconds to put the transceiver into the setup mode. The display will indicate the particular function and parameter that is being programmed. Refer to the Setup Menu section of this manual for details.

5) VOLUME/SQUELCH Controls - Independent controls permit setting the volume level and squelch threshold for receivers, 'A' and 'B'.

6) Microphone Connector - Four pin microphone connector. Wiring sense is as follows:

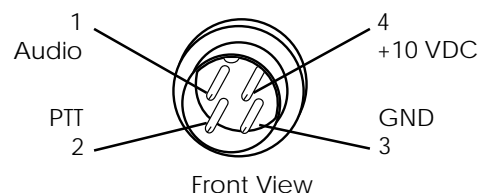

7) Speaker - This is the opening for the internal speaker.

8) Headphone Jack - This connector accepts a 1/8" mono headphone connector. The internal speaker and external speaker (if connected) are switched off when using the headphones.

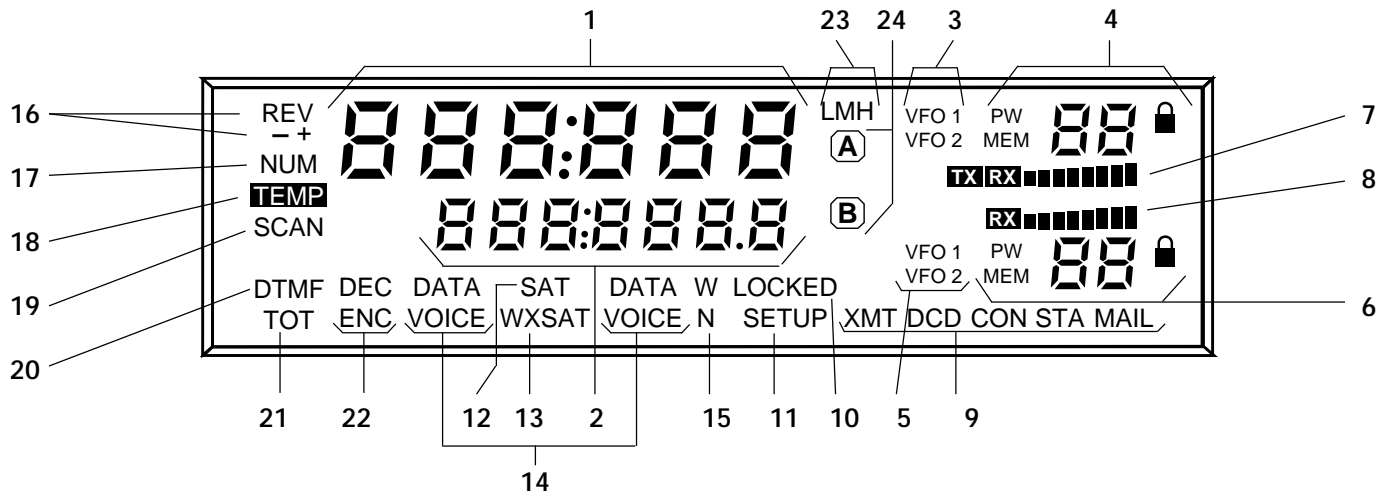

FIGURE 5 FRONT PANEL DISPLAY

1) 6-Digit Numeric Display Readout - This display indicates frequency, in 'MHz', for the 'A' transceiver's current VFO, Priority, or Memory channel. Frequencies from 144.000 to 148.000 MHz will be displayed*.

2) 7-Digit Numeric Display Readout - This display indicates frequency, in 'MHz', for the 'B' receiver's current VFO, Priority, or Memory channel. Frequencies from 136.0000 to 174.0000 MHz, or from 420.0000 to 470.0000 MHz will be displayed.

3) VFO 1/VFO 2 - Indicates the selected VFO for transceiver 'A'.

4) P/PW/MEM/88/🔒 for Transceiver 'A' - 'P' lights to indicate operation on the Priority channel. 'PW' lights to indicate that the Priority Watch mode is active. 'MEM' lights to indicate that the MEMORY mode is selected. The Memory channel number will be displayed adjacent to 'MEM' in the 2-digit display.

The 🔒 lights to indicate that the selected memory channel will be skipped during a memory scan.

5) VFO 1/VFO 2 - Indicates the selected VFO for receiver 'B'.

6) P/PW/MEM/88/🔒 for Receiver 'B' - Same functions as described for Item 4, but this section refers to receiver 'B'.

7 & 8) TX/RX Indicators - Displays Transmit (TX) mode and relative output power level or Receive (RX) mode and the relative signal strength. Item 7 refers to Transceiver 'A'; Item 8 refers to Receiver 'B'.

9) TNC STATUS Indicators (for optional TNC270 use) -

XMT - TNC is in the transmit state.

DCCD - Data Carrier Detect indicates that a valid data stream is present.



*142 - 150 MHz operation with proof of MARS or CAP license.

CON (connect) - TNC is connected to a station

STA (status) - TNC is reporting its status

MAIL - Flashes to indicate that a message is waiting.

10) LOCKED Indicator - Lights to indicate that all

keypad button functions,  /  buttons and tuning wheel are locked out.

11) SETUP - Lights when the transceiver is in the SETUP mode. SETUP parameters are then shown in various portions of the display as appropriate.

12) SAT - Lights to indicate that the transceiver 'A' and receiver 'B' are configured for the Satellite mode of operation.

13) WXSAT - Lights to indicate that the receiver 'B' is configured for the weather satellite mode of operation.

14) DATA/VOICE/Indicators - Separate indicators for Transceiver 'A' and Receiver 'B'.

DATA - Unit is in the DATA mode which permits TNC communications. When 'A' is in the DATA mode, TNC audio is sent to the transmitter and the front panel MIC input is disabled.

VOICE - Unit operates as a normal audio transceiver ('A') or receiver ('B'). The front panel MIC input is active when 'A' is in the VOICE mode.

A **STANDBY** mode is indicated as follows:
Transceiver 'A' - 'DATA', 'VOICE', 'SAT' and the frequency readout are all turned off.

Receiver 'B' - 'DATA', 'VOICE', 'WXSAT' and the frequency readout are all turned off.

15) W/N Indicators - Wide or narrow IF filter is selected for receiver 'B'.

16) - /+ /REV Indicators - Refers to transmit offset selection.

A) '-' lit: Receive frequency is displayed, transmit frequency is 600 kHz lower in frequency (unless variable offset is programmed).

B) '+' lit: Receive frequency is displayed, transmit frequency is 600 kHz higher in frequency (unless variable offset is programmed).

C) 'REV' lit: Receive frequency is displayed; receive and transmit frequency are interchanged, regardless of offset value: '-', or '+'.
D) Blank: Simplex mode. Transmit and receive frequencies are the same.

E) Both '-', and '+' lit: Variable offset-Receive frequency is displayed in the current VFO and the transmit frequency is in the other VFO.

17) NUM Indicator - When lit, keypad is in the numeric entry mode.

18) TEMP Indicator - When lit, maximum output power is being intentionally limited to avoid possible final amplifier damage due to excessive operating temperature.

19) SCAN Indicator - When lit, unit is in a VFO or MEMORY channel scan mode.

20) DTMF Indicator - Flashes to indicate that a phone number can be changed or dialed upon transmit.

21) TOT Indicator - Time-out-timer applied to the transmitter.

22) DEC/ENC Indicators - 'DEC' lights to indicate that the Continuous Tone Coded Squelch System (CTCSS) is active in the receive mode. 'ENC' lights to indicate that the CTCSS tone is transmitted. These DEC/ENC indicators apply to transceiver 'A' only.

23) L/M/H Indicators - Low, medium, and high power settings for transceiver 'A'.

24) / Indicators - A around either A or B indicates the active receiver for keypad or tuning entries.

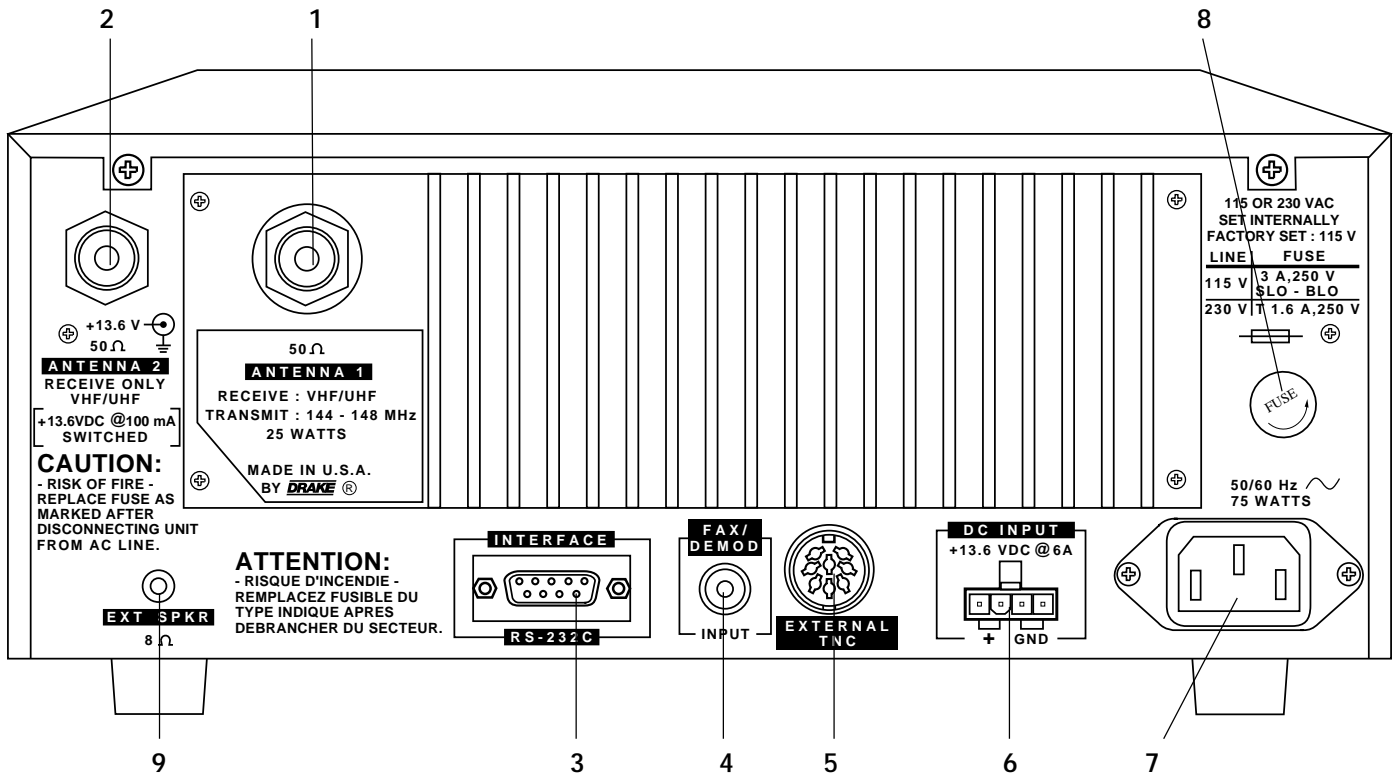

FIGURE 6 REAR PANEL

1) ANTENNA 1 - This connector is the antenna input/output of Transceiver 'A'. Attach a 50 Ohms nominal impedance coaxial feed line from the antenna. Ensure that the connected antenna is resonant in the 144 - 148 MHz (2-Meter) range prior to transmitting. This connector accepts a standard PL-259 plug.

2) ANTENNA 2 - This connector is the antenna input to Receiver 'B'. Attach a 50 Ohms nominal impedance coaxial feed line from the antenna. This connector accepts a standard PL-259 plug.

3) Interface RS-232C - This 9-pin DB-9 connector provides a standard RS-232C interface to a dumb terminal or PC. Refer to the COMPUTER CONTROL section of this manual.

4) FAX/DEMOD - This RCA connector is an audio input for CW, RTTY, HF/FAX, or WEFAX encoded signals that are to be demodulated by the optional DEMOD270 demodulator module. Input impedance is a nominal 600 Ohms. Provide a nominal 250 mVolt signal level for proper operation.

5) EXTERNAL TNC - This is an 8-pin DIN connector for an optional external TNC. Refer to the TNC's Operation Manual for wiring information. The pin numbers and descriptions are as follows:

Pin#	Description
1	TX OUT (1200 B)
2	GND
3	PTT
4	RX IN (1200 B)
5	SQUELCH STATUS
6	TX OUT (9600 B)
7	RX IN (9600 B)
8	SPARE (open)

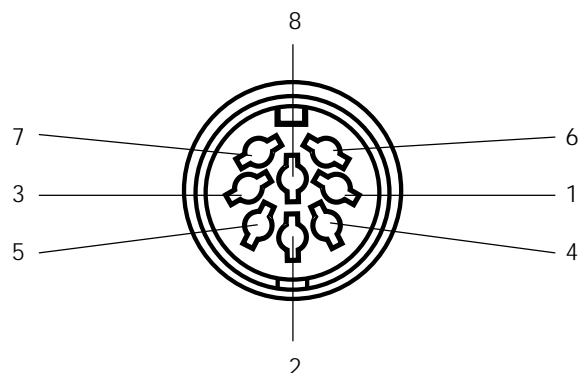

6) DC INPUT - This connector is used for powering the TR270 from an external DC source such as a car battery. Observe proper polarity when wiring the mating connector. This input is UNFUSED and thus requires an external (10 Amp, FAST BLOW) fuse to be wired in series with the external wiring supplying this connector. The transceiver will operate with a DC input voltage of 11-16 VDC. Full high power RF output during transmit is insured with a nominal supply voltage of 13.6 VDC or higher.

7) AC Power Cord Receptacle - This receptacle accepts a three-wire power cable. When the cable is connected to an appropriate power line outlet, the instrument is grounded. The unit is factory set and fused for operation on a nominal 115 VAC, 50/60 Hz mains supply and is shipped with a cord assembly intended for 115 VAC mains supply. Be certain of the mains supply voltage prior to connecting this unit. For operation of this unit on a nominal 230 VAC mains supply, refer to the SAFETY/VOLTAGE SELECTION section in this manual for internal connections and fusing value. Also use the proper cable assembly approved by your local codes for operation of this unit on nominal 230 VAC mains supplies.

8) AC Line FUSE - This unit is factory set for operation on nominal 115 VAC mains supply and a 3A, 250 V, SLO-BLO (5 x 20 mm) fuse is installed. For operation of this unit on a nominal 230 VAC mains supply, refer to the SAFETY/VOLTAGE SELECTION section of this manual for internal connections and fusing value.

9) External Speaker - This connector accepts a standard 1/8" diameter, 2-circuit, (monaural) phone plug for connection of an 8-Ohm external speaker. Inserting the phone plug into this connector switches off the internal speaker.

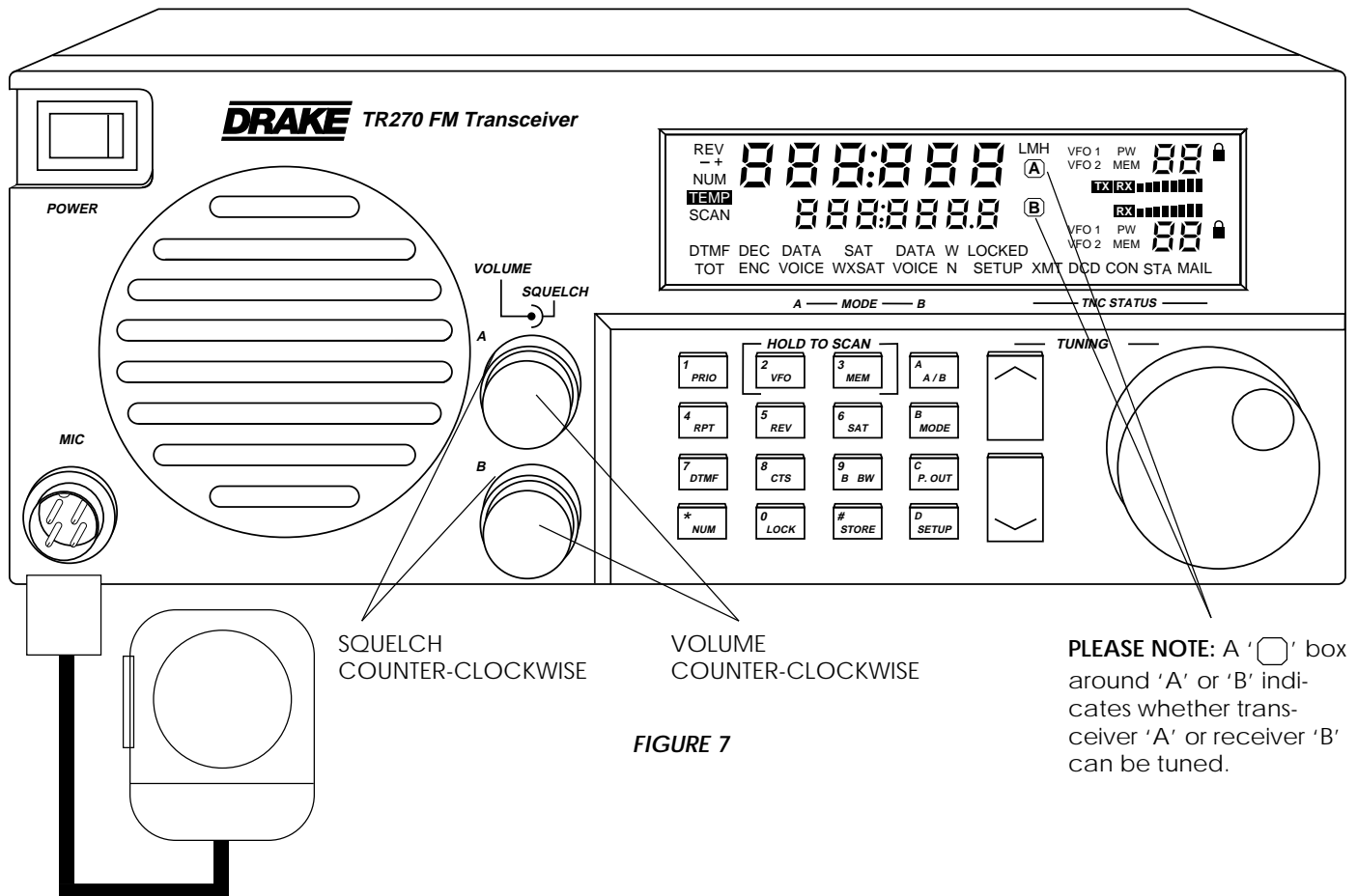

GENERAL OPERATING INFORMATION

This transceiver is easy to use. Please take a few moments to read through this section and familiarize yourself with general operating information.

BEEP TONES

The transceiver responds to all button depressions with an audible beep (unless the function is deactivated). They are as follows:

- 1 short tone for any button depression (if enabled within the Setup Menu).
- 3 short, rapid succession tones for confirmation.
- 1 long, low tone for any invalid button depressions.

GETTING STARTED

1. Make certain that an antenna is connected to the appropriate rear panel ANTENNA '1' connector. It is important that this antenna is resonant in the 144 - 148 MHz range and is capable of handling 25 Watts transmit RF power. An additional antenna can be connected to the ANTENNA '2' connector at this time also, if desired.

2. Please refer to FIGURE 7 and adjust the controls as shown. Connect the microphone.

3. Connect the transceiver to a source of AC power. Switch power on to the TR270 with the POWER switch. The front panel display should light and show VFO 1 selected for Receiver 'A'. If the upper frequency display is not shown (Standby condition), press the **MODE** button to display 'VOICE' in the lower left-hand portion of the display. Note that the frequency is displayed.



4. Adjust the appropriate VOLUME control ('A' or 'B') for a comfortable listening level.

5. Tune to the desired receive frequency by using one of several methods covered in this section.

6. Adjust the SQUELCH control at any time to set the desired received signal strength required to unmute the audio. Usually this control is set to a point that just quiets the receiver when not tuned to a station, and is for example, receiving noise. Rotating the control clockwise requires stronger signals to open the squelch.

7. Prior to transmitting, set low, medium, or high power for transmit by pressing the **P. OUT** button.

8. Press the microphone PTT button and begin speaking. The transmitted signal frequency is displayed during transmit.



9. To receive on the 'B' receiver, Press the  button to display a box around the 'B' () adjacent to the lower frequency (7-digit) readout. If the lower frequency display is not shown (Standby condition), press the  button to display 'VOICE' in the lower center portion of the display. Tune to the desired receive frequency by using one of several methods covered in this section (same methods as used for the 'A' receiver).

DUAL VFO's



TRANSCIEVER 'A' VFO 1 and VFO 2

Two VFO's (1 and 2) are provided for the 'A' transceiver. Selection is made with the  button when 'A' is selected. Each VFO can be set to any frequency in the 'A' tuning range and act as a temporary memory location.

For example, suppose you want 146.190 MHz in VFO 2 while using VFO 1 to tune other frequencies.



Press  to select VFO 2 and tune to 146.190 MHz. Press  to select VFO 1 and then tune other frequencies as desired. To recall VFO 2, Press the  button.

RECEIVER 'B' VFO 1 and VFO 2

Two VFO's (1 and 2) are also provided for the 'B' receiver. Selection is made with the  button when  is displayed. Each VFO can be set to any frequency in the 'B' tuning range and act as a temporary memory location. Programming is the same as explained for transceiver 'A'.

VFO 1 = VFO 2

This function is used to transfer the frequency of the active VFO into the inactive VFO. This is handy if you are tuning and would like to temporarily hold a certain frequency as you continue tuning. For example, suppose you are tuning in VFO 1 and come across a station at 146.190 MHz you would like to occasionally check.

Press the  button followed by  (3 confirmation beeps). Continue tuning and recall the station at 146.190 MHz anytime by Pressing the  button.

FREQUENCY STEP SELECTION



- Tuning Wheel Steps

Transceiver 'A': The transceiver can be programmed within the SETUP menu to tune in 5, 10, 15, 20, or 25 kHz steps.

Receiver 'B': The receiver can be programmed within the SETUP menu to tune in 5, 10, 12.5, 15, 20, or 25 kHz steps.

The tuning wheel incorporates two-speed tuning. Rotating the tuning wheel faster, results in an increased tuning speed.

-   Button Steps

The  button increases and the  button decreases the frequency by fixed 1 MHz step increments with each depression. The button may be held to auto-repeat the frequency change.

DIRECT FREQUENCY ENTRY







Direct keyboard entry of a frequency for either transceiver 'A' or receiver 'B' is possible by pressing the  button followed by the numeric buttons 0-9 (decimal point understood). With no activity, 'NUM' times out in approximately 3 seconds.



Transceiver 'A': Ensure that 'A' is selected. Press  followed by a numeric entry (6-digits maximum, 3-digits minimum) in the range of 144.000 to 148.000 MHz.

For example: Enter 146.190 MHz

With 'A' selected,

Press  (NUM is selected)

Press      

Receiver 'B': Ensure that  is displayed. Press  followed by a numeric entry (7-digits maximum, 3-digits minimum) in the range of 136.0000 to 174.0000 MHz or 420.0000 to 470.0000 MHz.

For example: Enter 162.4750 MHz

With 'B' selected,

Press  (NUM is selected)





Press       

A partial frequency may be stored quickly by using the  button. A minimum of three valid digits must be entered.

For example: Enter 144 MHz

with 'A' selected,

Press  (NUM is displayed)

Press    

NOTE: The SETUP mode can be entered **only from the Priority, VFO, or Memory states** (and from the special case of Inband or Crossband Repeater configuration).

RESTORE FACTORY SETUP SETTINGS

The TR270 is factory programmed for the default SETUP settings as shown in this section of the manual. To restore ALL factory SETUP settings: - With power off, press and hold the  button while switching the power on.

Press and hold the  button to display the SETUP menu:

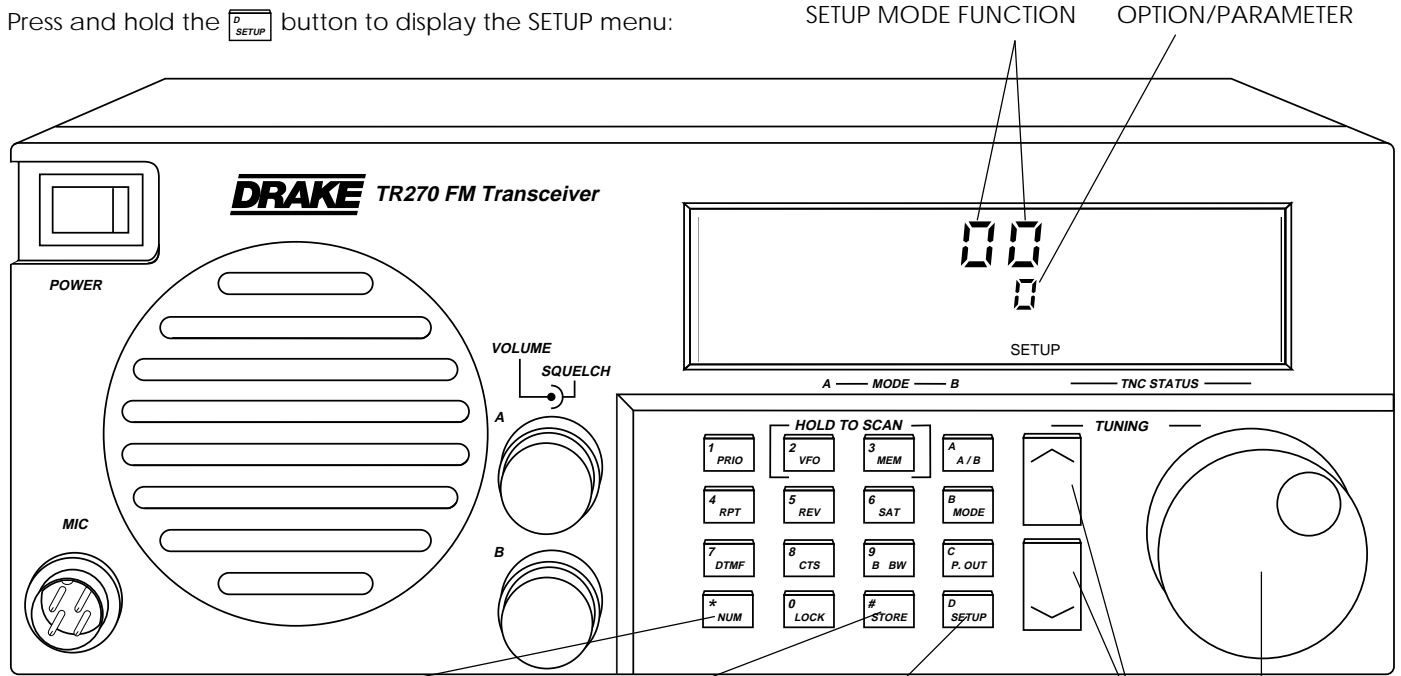



In numeric entry mode, press to clear a numeric field.







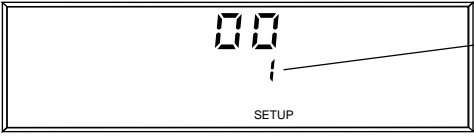
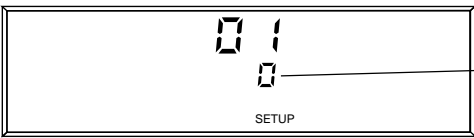

In numeric entry mode, press for quick frequency entry. (Minimum of three digits required).





Press and hold to enter the SETUP mode. Press to exit the SETUP mode.

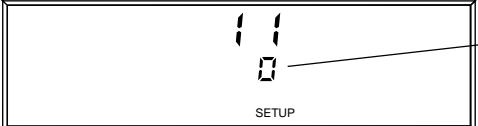

These buttons set the desired option or parameter.

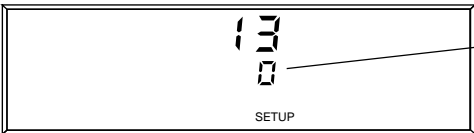

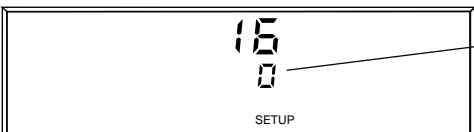
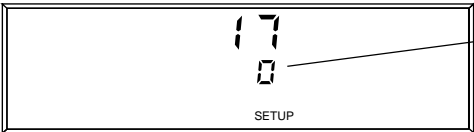
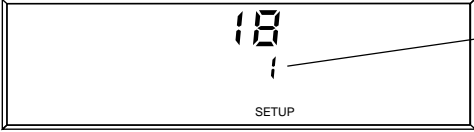
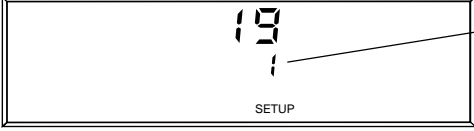





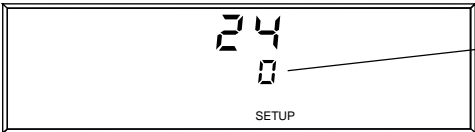
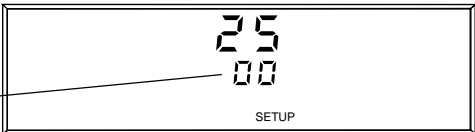
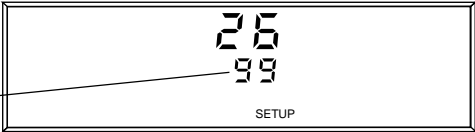
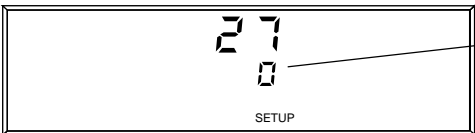
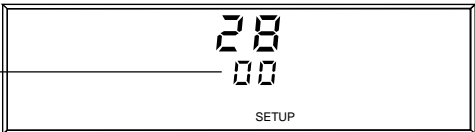
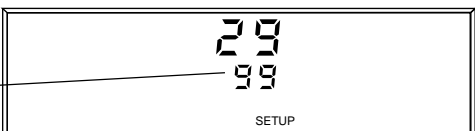

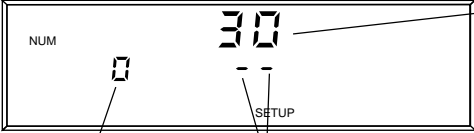



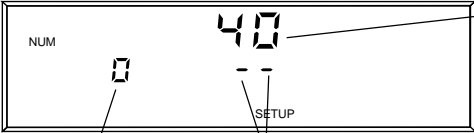

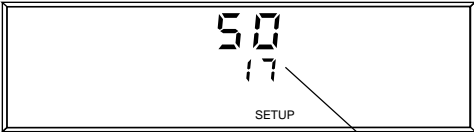

Rotate to select the desired SETUP function number.

SETUP MODE		OPTION / PARAMETER DESCRIPTION	DISPLAY (factory defaults shown)
NUMBER	FUNCTION		
00	Automatic Repeater Transmit Offset	0 = no offset 1 = automatic offset	 <p>0 or 1</p>
01	Set ANTENNA 2 DC Power On or Off	0 = Off 1 = On	 <p>0 or 1</p>
02	Priority Channel Action	0 = lock onto detected carrier on designated Priority channel 1 = sound audible beep when a carrier is detected on the Priority channel	 <p>0 or 1</p>

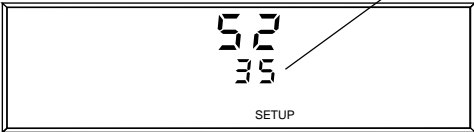
SETUP MODE		OPTION / PARAMETER DESCRIPTION	DISPLAY (factory defaults shown)
NUMBER	FUNCTION		
03	Flow Control for RS232 Transmission and Reception	0 = No flow control 1 = Hardware handshaking	
04	Tuning Wheel Step Size - Receiver 'A'	Set: 5, 10, 15, 20, or 25 kHz	
05	Tuning Wheel Step Size - Receiver 'B'	Set: 5, 10, 12.5, 15, 20, or 25 kHz	
06	Assign Internal TNC	0 = no TNC installed or unassigned 1 = assign to Transceiver 'A' 2 = assign to Receiver 'B'	
07	Assign External TNC	0 = no TNC connected or unassigned 1 = assign to Transceiver 'A' 2 = assign to Receiver 'B'	
08	External TNC Data Rate (if connected)	Set: 1200 or 9600	
09	DTMF Transmit Delay	Set: Delay = 250 mSec. X N where N = 0, 1, 2, 3, 4	
10	Demodulator Source (if DEMOD 270 demodulator card is installed)	0 = audio source internal to TR270 1 = audio source external to TR270	
11	Demodulation Type (if DEMOD 270 demodulator card is installed)	0 = AM demodulation 1 = FM demodulation	

SETUP MODE		OPTION / PARAMETER DESCRIPTION	DISPLAY (factory defaults shown)																
NUMBER	FUNCTION																		
1 2	Set audible beep on or off for any button depression	0 = no audible beep when button is pressed 1 = audible beep when button is pressed	 0 or 1																
1 3	Set for Normal or Crossband Repeater mode	0 = normal mode 1 = repeater mode	 0 or 1																
1 4	Time - Out - Timer on Transmit	Set: 0, 1, 2, 3, or 10 minutes 0= no time out	 0 or 1																
1 5	Assign Antenna Input(s) to Receiver 'B' (Receiver A Input is always from ANTENNA 1)	0 = Auto selection <table border="1" data-bbox="511 850 836 934"> <thead> <tr> <th>Frequency</th> <th>Receiver B Input</th> </tr> </thead> <tbody> <tr> <td>136-174MHz</td> <td>ANTENNA 1</td> </tr> <tr> <td>420-470 MHz</td> <td>ANTENNA 2</td> </tr> </tbody> </table> 1 = Auto selection <table border="1" data-bbox="511 987 836 1123"> <thead> <tr> <th>Frequency</th> <th>Receiver B Input</th> </tr> </thead> <tbody> <tr> <td>142-150MHz</td> <td>ANTENNA 1</td> </tr> <tr> <td>136-142MHz</td> <td>ANTENNA 2</td> </tr> <tr> <td>150-174MHz</td> <td>ANTENNA 2</td> </tr> <tr> <td>420-470 MHz</td> <td>ANTENNA 2</td> </tr> </tbody> </table> 2 = RECEIVER B Input is ANTENNA 1 3 = RECEIVER B Input is ANTENNA 2	Frequency	Receiver B Input	136-174MHz	ANTENNA 1	420-470 MHz	ANTENNA 2	Frequency	Receiver B Input	142-150MHz	ANTENNA 1	136-142MHz	ANTENNA 2	150-174MHz	ANTENNA 2	420-470 MHz	ANTENNA 2	 0, 1, 2 or 3
Frequency	Receiver B Input																		
136-174MHz	ANTENNA 1																		
420-470 MHz	ANTENNA 2																		
Frequency	Receiver B Input																		
142-150MHz	ANTENNA 1																		
136-142MHz	ANTENNA 2																		
150-174MHz	ANTENNA 2																		
420-470 MHz	ANTENNA 2																		
16	Methods for <u>VFO</u> SCAN Stop - Receiver A	For Setups #16,17,18, 19: SEEK (0) - Stop scan at first detected carrier and exit the scan mode. CARRIER (1) - Stop scan at a detected carrier, then resume scan 5 seconds after carrier drops. TIME (2) - Stop scan at a detected carrier, wait 5 seconds, and then resume scan. RESUME (3) - Stop scan at a detected carrier and resume scan immediately after carrier drops.	 0, 1, 2 or 3																
17	Methods for <u>VFO</u> SCAN Stop - Receiver B		 0, 1, 2 or 3																
18	Methods for Memory SCAN Stop - Receiver A		 0, 1, 2 or 3																
19	Methods for Memory SCAN Stop - Receiver B		 0, 1, 2 or 3																
20	Receiver A - Program START frequency endpoint for VFO Scan	Enter frequency (for example: 144.0000)	 0, 1, 2 or 3																

SETUP MODE		OPTION / PARAMETER DESCRIPTION	DISPLAY (factory defaults shown)	
NUMBER	FUNCTION			
21	Receiver A - Program STOP frequency endpoint for VFO Scan	Enter frequency (for example: 148.0000)		
22	Receiver B - Program START frequency endpoint for VFO Scan	Enter frequency (for example: 136.0000)		
23	Receiver B - Program STOP frequency endpoint for VFO Scan	Enter frequency (for example: 470.0000)		
24	Set Mode of Memory Scan for <u>Receiver A</u>	0 = All memory channels (00 - 99 possible) 1 = A range of memory channels 2 = A list of memory channels (one list of 10 channels)		
25	<u>Receiver A</u> : Program Memory Channel Number to Define START Endpoint for Range Scan	Press / to set desired number 00-99 (for example: 00)		
26	<u>Receiver A</u> : Program Memory Channel Number to Define STOP Endpoint for Range Scan	Press / to set desired number 00-99 (for example: 99)		
27	Set Mode of Memory Scan for <u>Receiver 'B'</u>	0 = All memory channels (00 - 99 possible) 1 = A range of memory channels 2 = A list of memory channels (one list of 10 channels)		
28	<u>Receiver 'B'</u> : Program Memory Channel Number to Define START Endpoint for Range Scan	Press / to set desired number 00-99 (for example: 00)		
29	<u>Receiver 'B'</u> : Program Memory Channel Number to Define STOP Endpoint for Range Scan	Press / to set desired number 00-99 (for example: 99)		

SETUP MODE		OPTION / PARAMETER DESCRIPTION	DISPLAY (factory defaults shown)	
NUMBER	FUNCTION			
30 . . 39	Receiver A: Construct Memory Channel List (ten lists with a maximum of 10 channels each list- Setup 30 - 39)	30 = List #0 31 = List #1 . . 38 = List #8 39 = List #9	 <p>30 - 39</p> <p>List index 0 - 9 with  </p> <p>Enter a 2-digit memory number. Press  to clear the entry.</p>	
40 . . 49	Receiver 'B': Construct Memory Channel List (ten lists with a maximum of 10 channels each list- Setup 40 - 49)	40 = List #0 41 = List #1 . . 48 = List #8 49 = List #9	 <p>40 - 49</p> <p>List index 0 - 9 with  </p> <p>Enter a 2-digit memory number. Press  to clear the entry.</p>	
50 51 52	Set Low level Transmit Power Set Medium level Transmit Power Set High level Transmit Power	NOTE: Power output is factory set as follows: LOW - 1 Watt, nominal MEDIUM - 10 Watts, nominal HIGH - 25 Watts, nominal The parameters shown are for example only. For each level, Low, Medium, or High, press  /  to modify the factory set parameter ± 3 counts. This action will vary the power \pm of the factory set power. Actual power output can be checked with a calibrated RF Wattmeter, if desired.	   <p>Parameters are shown for example only.</p>	
53 54	Sets the scanned frequency range for the SAT SCAN operation Sets the time between frequency adjustments for the SAT LOCKED (Doppler Tracking) operation	Press  /  to set the \pm Tuning range of the Scan Start frequency, in kHz (for example, to set ± 10 kHz range, set the number 10). Press  /  to set the time between frequency adjustments, (for example, to set 0.5 second, set the number 05).	 <p>00 = ± 0 Hz 01 = ± 1 kHz . . 99 = ± 99 kHz</p>  <p>00 = 0 Second 01 = 0.1 Second . . 99 = 9.9 Seconds</p>	

SETUP MODE		OPTION / PARAMETER DESCRIPTION	DISPLAY (factory defaults shown)	
NUMBER	FUNCTION			
55	Sets the delay time between the end of a SAT LOCKED condition and the continuation of SAT SCAN	Press / to set the Delay time prior to resuming SAT SCAN, (for example, to set 5 seconds, set the number 05).		00 = SAT SCAN does not resume 01 = 1 Second before SAT SCAN resumes . . . 99 = 99 Seconds before SAT SCAN resumes
56	Set LCD backlight intensity	Press / to set the relative intensity level (for example: 99)		00 = Dim . . . 99 Bright
57	Set repeater mode high pass audio filter on or off	0 = filter off 1 = filter on		0 or 1
58	Set transmit microphone audio filter on or off	0 = filter off 1 = filter on		0 or 1
59	Set Receiver 'A' subaudible tone filter on or off	0 = filter off 1 = filter on		0 or 1
60	Set Receiver 'B' subaudible tone filter on or off	0 = filter off 1 = filter on		0 or 1

The TR270 has 400 programmable memory locations that are allocated as follows:

Transceiver 'A': 100 memories.

Receiver 'B': 100 memories, plus 100 additional memories assigned to 'WXSAT'.

'SAT' (satellite) mode: 100 memories



These memories can be used to store and recall commonly monitored or operated frequencies. Additionally, two different VFO frequencies and a priority frequency can be programmed for each of transceiver 'A' and receiver 'B'.

With memory locations programmed, various scan functions can be used to automatically monitor desired memory frequencies. The following may be stored in appropriate memory locations:

- 1) Frequency
- 2) Transceiver 'A': Simplex or Repeater mode with \pm offset.
- 3) VOICE or DATA mode
- 4) Transceiver 'A': CTCSS Encoder and/or Decoder status and frequency.
Receiver 'B': CTCSS Decoder status and frequency.
- 5) Lock / unlock status

MEMORY CHANNEL PROGRAMMING

Select a frequency by any tuning or selection method. Selection methods include:

- 1) Press the  button to select the PRIORITY frequency.
- 2) Press the  button to select one of two VFO frequencies for the selected transceiver 'A' or for receiver 'B'.
- 3) Press the  button to select 1 of 100 possible

memory locations. Turn the tuning wheel, press  /



buttons, or press  followed by a 2-digit number



entry (00-99) for the desired memory location.







Make any adjustments desired, for example; CTS or RPT settings.

Whatever is displayed can be stored by one of the following procedures:

- Press  followed by  to store the displayed frequency into the selected VFO.

- Press  followed by  to store the displayed frequency into the priority channel.





- Press  followed by  for a flashing memory number indication. Enter a 2-digit number (00-99) using the numeric buttons (this operation automatically function shifts the buttons to the NUM mode) to store the displayed frequency to the desired memory location.



- To load successive memory locations quickly, start in the VFO mode with the first desired frequency and the desired starting memory channel number. From the VFO mode, press , ,  to store the displayed frequency to the previously displayed memory number, advance the memory channel by one, and return to the VFO mode. Tune to a new frequency and Press , , . Continue repeating the process.

RECALLING A MEMORY CHANNEL

From the VFO mode, Press the  button followed by  and a 2-digit numeric entry corresponding to the desired memory channel. From the MEMORY mode, additional memory channels are tuned by turning the

tuning wheel, using the  /  buttons to increment

the memory channel, or by pressing  followed by a 2-digit numeric entry. To frequency tune after recalling a memory channel, press , . After the confirmation beeps, press the  button and then frequency

tune as desired using the tuning wheel,  / 

buttons, or by direct numeric entry.

CHANGING A MEMORY CHANNEL

An individual memory channel is changed by storing a new frequency and associated parameters to the same location.



CONSTRUCT A MEMORY LIST

10 lists (0-9), each containing a maximum of any 10 memory channels (00-99 available), can be constructed for both receiver 'A' and receiver 'B' for the purpose of scanning the channels contained in the respective lists.

Receiver 'A':

Setup Mode #24 - set for '2', and

Setup Mode #30 - Selects list #0. Construct the list with a maximum of 10 channels. From Setup #30, index from 0-

9 with the  /  buttons, Press  followed by a 2-digit numeric entry for each desired memory channel.

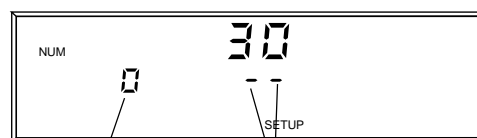
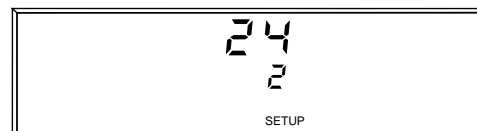

List index 0 - 9



with  

Enter a 2-digit memory

number, or press  to clear the entry.

Receiver 'B':

Setup Mode #27 - set for '2', and
Setup Mode #40 - Selects list #0. Construct the list with a maximum of 10 channels. From Setup #40, index from 0-9

with the  /  buttons, Press  followed by a 2-digit numeric entry for each desired memory channel.

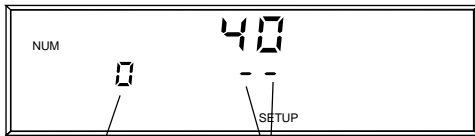

List index 0 - 9

with  



Enter a 2-digit memory number, or press  to clear the entry.



LOCKING A MEMORY CHANNEL



Memory channels tagged with the  symbol will be skipped during the scan process.

First be sure the receiver is in the VFO mode (MEM or SCAN not displayed).

A) Press  and select the desired memory location

with the  /  buttons, or by direct entry of a two-digit memory channel number.

B) To lock out a memory channel: Press . The  symbol lights adjacent to the memory channel number.

To unlock a memory channel, Press . The  symbol will extinguish.

RESTORE FACTORY MEMORY PROGRAMMING

With power off, press and hold the  button while switching the power to 'On'. This action does the following:

- initializes all 400 memory channels, including standard repeater and packet frequencies in transceiver 'A'.
- clears all DTMF phone numbers.
- initializes all power-on variables.
- initializes priority channels.
- disables MARS/CAP operation.

The TR270 is capable of several different methods and modes of scanning frequencies.

Both Receiver 'A' and Receiver 'B' provide the following:

Scan Mode: Either VFO or Memory

Scan Method:

SEEK (0) - Stop scan at first detected carrier and exit the scan mode.

CARRIER (1) - Stop scan at a detected carrier, then resume scan 5 seconds after carrier drops.

TIME (2) - Stop scan at a detected carrier, wait 5 seconds, and then resume scan.

RESUME (3) - Stop scan at a detected carrier, then resume scan immediately after carrier drops.

Additionally, the subaudible tone squelch may be enabled for either receiver. Either a VFO or Memory scan may be initiated for each receiver.

A mode and a method are programmed together.

Before performing any scan functions, please read NOTE 1 and NOTE 2.

NOTE 1:

First, it is important to understand how SCAN Range works. Example A refers to two types of VFO scan and Example B refers to two types of Memory scan.

Example A: VFO SCAN

1) Programmed (in SETUP) START frequency limit is lower than the programmed STOP frequency limit:

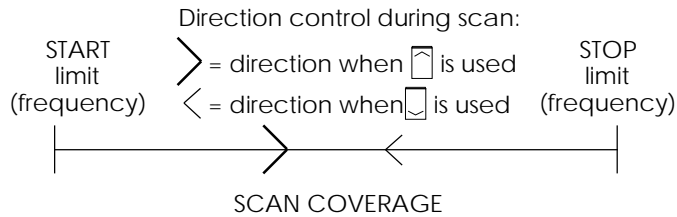

- OR -

2) Programmed (in SETUP) START frequency limit is higher than the programmed STOP frequency limit:

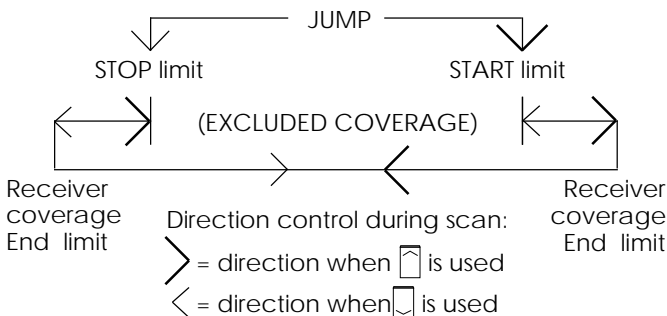

Example B: MEMORY SCAN

1) Programmed (in SETUP) START memory channel number limit is lower than the programmed STOP memory channel number limit:

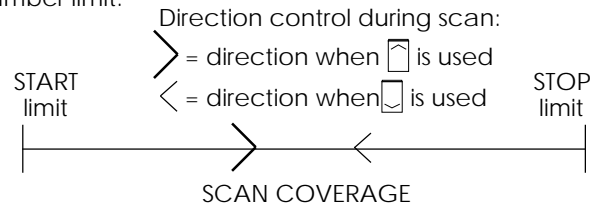



- OR -

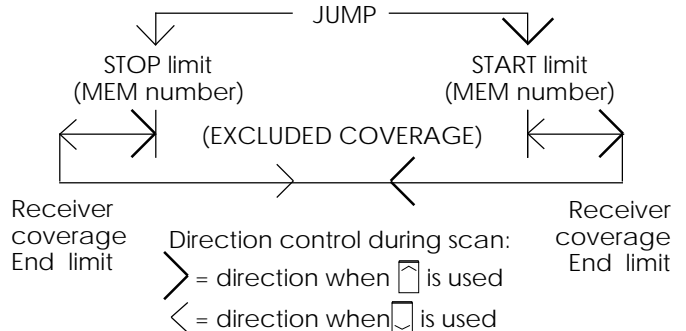



2) Programmed (in SETUP) START memory channel number limit is higher than the programmed STOP memory channel number limit:



NOTE 2:



1. Signal detection (stop scan on detected carrier) is dependent upon the strength of the signal, the squelch control setting, and the status of the preprogrammed subaudible tone squelch decoder (CTCSS "off" or "on").

2. Press the  /  buttons during scan to reverse the direction of scan, if desired. When starting a scan, the direction is always the same as the last time a scan was ended.

3. To interrupt a scan on either receiver, first press the  button to select the particular receiver. Press the , , or  to exit the scan mode for that selected receiver.

4. While one receiver is being scanned, the opposite receiver (transceiver) can be operated in the normal mode, or set to scan simultaneously.

5. The receiver can be tuned during scan, if desired. It may be useful to tune away from an active frequency, to resume scanning, for example (in all scan stop methods except SEEK). A frequency can also be entered during scan (press  followed by numeric entry). After the carrier drops (CARRIER and RESUME) or timeout (TIME) on the tuned frequency, the scan will resume within the programmed (in SETUP) range limits.

Press and hold the  button to start a VFO scan. Press and hold the  button to start a Memory scan. In all cases, prior to starting a scan, adjust the SQUELCH control for the appropriate receiver to a setting that just quiets the receiver.

SCAN MEMORY

- SCAN **ALL UNLOCKED MEMORY CHANNELS**

For Receiver 'A':

1) Select SETUP #24 - set to '0'





2) Select SETUP #18 - set to: '0' for a Seek scan
'1' for a Carrier scan
'2' for a Time scan
'3' for a Resume scan





3) Exit the SETUP mode.

4) Press the  button to select Receiver 'A'.

5) Press and hold the  button to start the scan.

Press the  /  buttons during scan to reverse the scan direction, if desired.

6) Press the , , or  button to exit the scan mode.

For Receiver 'B':

1) Select SETUP #27 - set to '0'.





2) Select SETUP #19 - set to: '0' for a Seek scan
'1' for a Carrier scan
'2' for a Time scan
'3' for a Resume scan





3) Exit the SETUP mode.

4) Press the  button to select Receiver 'B'.

5) Press and hold the  button to start the scan.

Press the  /  buttons during scan to reverse the scan direction, if desired.

6) Press the , , or  button to exit the scan mode.

-SCAN ALL UNLOCKED MEMORY CHANNELS WITHIN A PROGRAMMED RANGE OF MEMORY CHANNELS.

For Receiver 'A':

- 1) Select SETUP #24 - set to '1'.



- 2) Select SETUP #25 - set to the desired memory channel number to define the START endpoint for a Range Scan.



- 3) Select SETUP #26 - set to the desired memory channel number to define the STOP endpoint for a Range Scan.



- 4) Select SETUP #18 - set to: '0' for a Seek scan
'1' for a Carrier scan
'2' for a Time scan
'3' for a Resume scan



- 5) Exit the SETUP mode.

- 6) Press the button to select Receiver 'A'.

- 7) Press and hold the button to start the scan.

Press the / buttons during scan to reverse the scan direction, if desired.

- 8) Press the , , or button to exit the scan mode.

For Receiver 'B':

- 1) Select SETUP #27 - set to '1'.

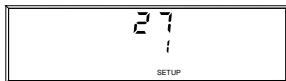

- 2) Select SETUP #28 - set to the desired memory channel number to define the START endpoint for a Range Scan.



- 3) Select SETUP #29 - set to the desired memory channel number to define the STOP endpoint for a Range Scan.



- 4) Select SETUP #19 - set to: '0' for a Seek scan
'1' for a Carrier scan
'2' for a Time scan
'3' for a Resume scan



- 5) Exit the SETUP mode.

- 6) Press the button to select Receiver 'B'.

- 7) Press and hold the button to start the scan.

Press the / buttons during scan to reverse the scan direction, if desired.

- 8) Press the , , or button to exit the scan mode.

-SCAN A LIST OF MEMORY CHANNELS (ONE LIST OF 10 CHANNELS)

For Receiver 'A':

Select LIST scanning:

- 1) Select SETUP #24 - set to '2'.

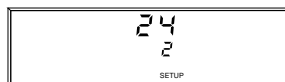

Select a List and Setup channels in the List:

- 2) Select SETUP #30 (List #0) through #39 (List #9).



- 3) Construct the list by pressing the / buttons to select the List index number (0 - 9) and entering the desired 2-digit memory channel number at that selected List index number. [Press to clear a List index number (— will appear at a cleared List index number)].
- Setup additional lists by repeating steps 2 and 3.

Select a Scan STOP method:

- 4) Select SETUP #18 - set to: '0' for a Seek scan
'1' for a Carrier scan
'2' for a Time scan
'3' for a Resume scan



- 5) Exit the SETUP mode.

To start a List scan:

- 6) Press the button to select Receiver 'A'.

- 7) Press and hold the button, followed by the numeric entry of the desired List index number (0 -9), to start the scan.

- 8) Press the , , or to exit the scan mode.

For Receiver 'B':Select LIST scanning:

1) Select SETUP #27 - set to '2'.

Select a List and Setup channels in the List:

2) Select SETUP #40 (List #0) through #49 (List #9).



3) Construct the list by pressing the / buttons to select the List index number (0 - 9) and entering the desired 2-digit memory channel number at that selected List index number. [Press to clear a List index number (— will appear at a cleared List index number)]. - Setup additional lists by repeating steps 2 and 3.

Select a Scan STOP method:

4) Select SETUP #19 - set to: '0' for a Seek scan



'1' for a Carrier scan
'2' for a Time scan
'3' for a Resume scan

5) Exit the SETUP mode.

To start a List scan:

- 6) Press the button to select Receiver 'B'.
- 7) Press and hold the button, followed by the numeric entry of the desired List index number (0 - 9), to start the scan.
- 8) Press the , , or to exit the scan mode.

SCAN VFO

A VFO scan permits continuous tuning of frequencies between two programmed limits.

For Receiver 'A':

1) Select SETUP #20 - enter the START frequency endpoint from 144 - 148 MHz.



2) Select SETUP #21 - enter the STOP frequency endpoint from 144 - 148 MHz.



3) Select SETUP #04 - set to 5, 10, 15, 20, or 25 kHz step size.



4) Select SETUP #16 - set to: '0' for a Seek scan



'1' for a Carrier scan
'2' for a Time scan
'3' for a Resume scan

5) Exit the SETUP mode.

- 6) Press the button to select Receiver 'A'.
- 7) Press and hold the button to start the scan.

Press the / buttons during scan to reverse the scan direction, if desired.

8) Press the , , or to exit the scan mode.

For Receiver 'B':

1) Select SETUP #22 - enter the START frequency endpoint from 136 - 174 MHz or 420 - 470 MHz.



2) Select SETUP #23 - enter the STOP frequency endpoint from 136 - 174 MHz or 420 - 470 MHz.



3) Select SETUP #05 - set to 5, 10, 12.5, 15, 20, or 25 kHz step size.



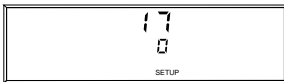

4) Select SETUP #17 - set to: '0' for a Seek scan
'1' for a Carrier scan
'2' for a Time scan
'3' for a Resume scan





5) Exit the SETUP mode.

6) Press the  button to select Receiver 'B'.

7) Press and hold the  button to start the scan.



Press the  /  buttons during scan to reverse the scan direction, if desired.



8) Press the , , or  to exit the scan mode.

LOCKING A MEMORY CHANNEL

Memory channels tagged with the  symbol will be skipped during the scan process.

A) Press  and select the desired memory location

with the  /  buttons, or by direct entry of a two-digit memory channel number. If recalling an unprogrammed memory channel with direct entry, an error beep is heard.

B) To lock out a memory channel: Press . The symbol lights adjacent to the memory channel number. To unlock a tagged memory channel, Press . The  symbol will disappear.



VOICE OPERATION

The TR270 is capable of FM voice operation over a simplex or repeater frequency pair. Additionally, by using receiver 'B', a crossband repeat function is also available. Other selectable options include subaudible tone encode/decode, receiver subaudible tone filter selection, and full DTMF [Dual-Tone Multi Frequency; Touch Tone®] operation.



NOTE: VOICE/DATA modes can be stored using memory channels. Factory defaults are set appropriately for many areas of the United States.

FM SIMPLEX OPERATION

To receive:

- 1) Select receiver 'A' and VFO 1.
- 2) Tune to the desired frequency by either the main tuning wheel,  /  buttons, or by direct entry.
3. Adjust the volume control for a comfortable listening level.
4. Adjust the squelch control as required. The control is usually set to a point where the receiver audio just mutes when no stations are being received.

To transmit:

- 1) Be certain that the VOICE mode has been selected with the  button.
- 2) Press the  button until '+' or '-' is extinguished. If the indicated frequency is a standard simplex frequency, and SETUP #00 is set for '1' (factory default setting), the '+' or '-' will be automatically turned off.
- 3) Press the  button to select the desired transmit power, remembering that it is good practice to use as little power as necessary to establish a contact.
- 4) Monitor the frequency prior to actually transmitting to ensure that you will not interfere with anyone else trying to use the frequency.
- 5) Press and hold the PTT (Push-to-talk) button on the microphone and speak into the microphone at a normal voice level.
- 6) Release the PTT button when you are finished speaking to return the TR270 to the receive mode.

REPEATER OPERATION

Repeater operation allows communications over far greater distances than the simplex mode usually provides. Typically the repeater is located on a tall structure or mountain. Repeaters are designed to receive on a certain input frequency and repeat on a different output frequency. The input and output frequencies are separated by an offset frequency, usually + or - 600 kHz. Most amateur radio repeaters utilize this 'Standard' offset format. In some rare instances, this standard offset is abandoned, and the input and output frequency offset is a 'Custom' offset format. The TR270 is capable of handling both 'Standard' and 'Custom' offsets.

STANDARD OFFSETS



TR270 Repeater Offsets (Auto mode, Setup #00 = 1):

Repeater Frequency (MHz)	Offset
144.000 - 145.095	Simplex
145.100 - 145.495	-600 kHz
145.500 - 145.995	Simplex
146.000 - 146.395	+600 kHz
146.400 - 146.595	Simplex
146.600 - 146.995	-600 kHz
147.000 - 147.395	+600 kHz
147.400 - 147.595	Simplex
147.600 - 147.995	-600 kHz

To receive:



- 1) Select the desired frequency as was described for the Simplex mode of operation.
- 2) Adjust the volume control for a comfortable listening level.
- 3) Adjust the squelch control as required.

To transmit:

- 1) Be certain that the VOICE mode has been selected with the  button.
- 2) Select a 'Standard' offset with the  button appropriate for the repeater frequency. If the indicated frequency is in a 'Standard' offset range as outlined in the previously listed table, and SETUP #00 is set for '1' (factory default setting), the TR270 will automatically select and display the proper offset.
- 3) Press the  button to select the desired transmit power. Usually a Low power setting is sufficient to 'hit' the repeater (provide a good quality signal to the repeater).
- 4) Monitor the frequency prior to actually transmitting to ensure that you will not interfere with anyone else trying to use the repeater.
- 5) Press and hold the PTT (Push-to-talk) button on the microphone and speak into the microphone at a normal voice level. The display will change to indicate the transmit frequency.
- 6) Release the PTT button when you are finished speaking to return the TR270 to the receive mode.

CUSTOM OFFSETS

Sometimes, the input and output frequencies of a repeater will not follow a "standard" convention. For example, the input frequency could be located at one end of the 2-meter band, and the output located at the other end of the band. This type of repeater would require a "custom" offset. The TR270 is easily programmed for "custom" offsets.

- 1) Press the  button to set the VOICE mode, if not already set.
- 2) Enter a valid transmit frequency in VFO 1.
- 3) Enter a valid receive frequency in VFO 2.
- 4) Press and hold the  button until **both** the '+' and '-' indicators are displayed.

- 5) Monitor the frequency prior to actually transmitting to ensure that there is no interference with others trying to use the repeater.
- 6) Press and hold the PTT button on the microphone and speak into the microphone at a normal voice level. The display will change to indicate the transmit frequency.
- 7) Release the PTT button when you are finished speaking to return the TR270 to the receive mode.





SUBAUDIBLE TONE OPERATION

The TR270 includes a subaudible encoder/decoder for transceiver 'A' and a separate decoder for receiver 'B'. 'A' and 'B' tone frequencies may be set independently of each other. 'A' may be set to encode only, or to encode and decode. Encoding only will be used when you need to transmit the tone to open the subaudible squelch of a repeater or of any other receiver with subaudible tone squelch activated, but you wish to hear any signals that exceed the signal level threshold set by the squelch control. If you desire the TR270 to only respond to signals transmitting a subaudible tone, the decode function may be activated as well. The status of the encoder and decoder for transceiver 'A' is always shown on the LCD display. To see the status of the decoder for receiver 'B', press the  button once when the 'B' receiver is selected for tuning.

If the TR270 is used frequently for receiving signals that are transmitting continuous subaudible tones, it may be desirable to reduce the level of the tone heard in the speaker by enabling a high pass filter. Program SETUP #59 for a '1' to enable the filter for receiver 'A'; program SETUP #60 for a '1' to enable the filter for receiver 'B'. In the repeat mode, program SETUP #57 for a '1' to enable a high pass filter in the audio path. Finally, if you are using CTCSS encoding, and the receiving station experiences "talk off" (squelching on voice peaks), program SETUP #58 for a '1' to enable a high pass filter for the microphone audio. All of these high pass filters have a cutoff frequency of approximately 300 Hz. Expect some noticeable loss of low frequency audio response if the filters are enabled.

Transceiver 'A' -



To Enable Tone Encode and /or Tone Encode/Decode: Press the  button to select receiver 'A', if necessary.



- 1) Press the  button once, and within 3 seconds,
- 2) Dial in the desired subaudible tone frequency, using the main tuning wheel.
- 3) With the tone frequency displayed, press the  button again to enable tone ENCode.
- 4) Press the  button again to enable tone ENCode/DECode.
- 5) Press the  button again to turn the tone Off.

Receiver 'B' -

To Enable or Disable Tone Decoding:

Press the  button to select receiver 'B', if necessary.

- 1) Press the  button once to see the present setting ('OFF' indicates that the decoder is disabled), and within 3 seconds,
- 2) Rotate the tuning wheel or press  /  buttons to set the desired tone frequency. Allow display to time out. The encoder is now enabled.

Press the  button at any time to review the current setting. Press the  button a second time before the display times out to toggle between on (tone frequency displayed) or 'OFF' without changing the programmed decode frequency.

Subaudible Tone Table:

Nominal Tone Frequency (Hz)

67.0	94.8	131.8	179.9	218.1
69.3	97.4	136.5	183.5	225.7
71.9	100.0	141.3	186.2	229.1
74.4	103.5	146.2	189.9	233.6
77.0	107.2	151.4	192.8	241.8
79.7	110.9	156.7	196.6	250.3
82.5	114.8	159.8	199.5	254.1
85.4	118.8	162.2	203.5	
88.5	123.0	167.9	206.5	
91.5	127.3	173.8	210.7	

DTMF OPERATION

Some repeaters use DTMF (Touch Tone ®) for control purposes and to allow users of the repeater to make telephone calls (Autopatch) through the repeater. The TR270 is capable of generating DTMF tones for this purpose.

DTMF Tone Table:

FREQUENCY (Hz)	1209	1336	1477	1633
697	1	2	3	A
770	4	5	6	B
852	7	8	9	C
941	*	0	#	D

The DTMF tones are available anytime the TR270 PTT is pressed.

TO USE DTMF TONES

- 1) Press PTT on the microphone.
- 2) Press buttons 0-9, A-D, or *, #.



The microphone audio is muted during the time each button is held.

The TR270 permits up to ten, 14-digit DTMF sequences to be programmed and stored in memory. Additionally, two methods of dialing are available.

Downloaded by 

Amateur Radio Directory

TO STORE A PHONE NUMBER

- 1) Press the  button, and within 5 seconds, Press 0-9 to select a DTMF sequence memory location.
- 2) Begin entering the phone number. The display will automatically scroll the entered numbers to the left. To view or edit a phone number, rotate the main tuning wheel to scroll and highlight the desired digit that is to be edited. The digit will flash. Enter the new number at that digit location.
- 3) To erase the entered number and start over, Press the  button to clear the display.
- 4) When all numbers have been entered, Press the  button to store the number.

TO TRANSMIT A STORED PHONE NUMBER**DIALING IF THE PHONE NUMBER IS TO BE DISPLAYED**

- 1) Press the  button, and within 3 seconds,
- 2) Select 0-9 (stored phone number will be displayed).
- 3) Press PTT on the microphone.
- 4) The displayed phone number will be transmitted after any delay as set by setup #9.
- 5) For a pause between digits, skip around dashes when entering a phone number. For example, entering 9 - - 5551212 would add a pause between '9' and '5'.

DIALING IF THE PHONE NUMBER IS NOT TO BE DISPLAYED

(This mode permits some measure of security against casual viewing of the phone number. Although most repeaters will require manual detection of the dial tone following any required access tone dialing, the access dial number could be recalled from a separate "phone number" memory location and dialed. For this example, the following procedure would "conceal" the number).

- 1) Press the  button.
- 2) Press PTT on the microphone.
- 3) Select 0-9 (phone number, access number will NOT be displayed)
- 4) The phone number will be transmitted.

Setup mode #9 sets the amount of transmit delay in 250 mSec. increments: 0 = NONE, 1 = 250 mSec., 2 = 500 mSec., 3 = 750 mSec., 4 = 1000 mSec. The delay allows the repeater sufficient time to stabilize following the PTT action and before the first tone is actually transmitted.





INBAND REPEAT AND CROSSBAND REPEAT OPERATION

The TR270 can be configured to use the 'B' receiver and 'A' transmitter as a repeater.

Two available methods of repeater mode are Inband repeat and Crossband repeat.

To use the Inband repeat mode, two separate antennas or external duplexer are required.

INBAND REPEAT:

- 1) Press the  button to select Transceiver 'A'. Press  followed by the numeric entry of the desired Transmit frequency.
- 2) Press the  button to select Receiver 'B'. Press  followed by the numeric entry of the desired Receive frequency. Setup any CTS tones or audio filter as desired.
- 3) Select SETUP #15 - set to '3' (configures antenna inputs properly).

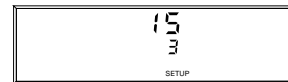

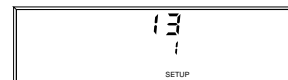

- 4) Select SETUP #13 - set to '1'.

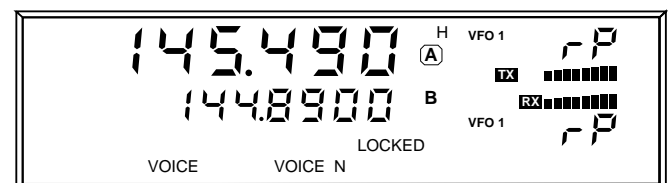

This action places the unit in the repeater mode, with the tuning wheel and front panel buttons locked out, except for the  button. "rP" is displayed for both (transmitter) 'A' and (receiver) 'B'.

For example:







- 5) To cancel the Repeat mode function, press and hold the  button until the SETUP #13 is displayed. Set the parameter to '0' in SETUP #13.



To use the Crossband repeat mode, only a single antenna is required since the TR270 has an internal crossband duplexer. Two separate antennas may also be used.

CROSSBAND REPEAT (RECEIVE- UHF RANGE, TRANSMIT-2M):

- 1) Press the  button to select Transceiver 'A'. Press  followed by the numeric entry of the desired Transmit frequency.
- 2) Press the  button to select Receiver 'B'. Press  followed by the numeric entry of the desired UHF Receive frequency.
- 3) Select SETUP #15 - set to '2' if one antenna is used or '3' if separate antennas are used.





- 4) Select SETUP #13 - set to '1'.

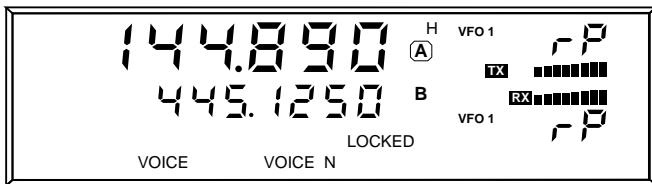

This action places the unit in the repeater mode, with the tuning wheel and front panel buttons locked out, except for the  button. "rP" is displayed for both (transmitter) 'A' and (receiver) 'B'.

For example:





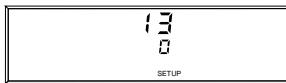



- 5) To cancel the Repeat mode function, press and hold the  button until the SETUP #13 is displayed. Set the parameter to '0' in SETUP #13.



For both repeater modes, CTCSS decode and/or tone filtering may be selected for Receiver 'B'. Additionally, CTCSS encode may be selected for Transceiver 'A'.

RECEIVER 'B' SUBAUDIBLE TONE DECODE:

If the subaudible tone decoder is enabled for receiver 'B', the transmitter will not be keyed unless the ('B') received signal has the selected subaudible tone present.

- 1) Press the  button to select Receiver 'B'.
- 2) Press the  button. Within 3 seconds, rotate the tuning wheel or press  /  buttons to set the desired subaudible tone frequency. After approximately 3 seconds with no change in selection, the display returns to showing the receiver operating frequency (press  button for immediate store). The  button can be used to toggle between the last set frequency tone and 'OFF'.
- 3) To cancel the subaudible tone on receive, press the  button to display 'OFF'.

RECEIVER 'B' SUBAUDIBLE TONE REPEAT FILTER:



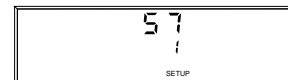





- 1) Press the  button to select Receiver 'B', as required.
- 2) Select SETUP # 57 - set to '1'.



- 3) Exit the SETUP mode.
- 4) To cancel the filter, select SETUP #57 - set to '0'.



TRANSCIEVER 'A' SUBAUDIBLE TONE ENCODE/DECODE:

- 1) Press the  button to select Transceiver 'A'.
- 2) Press the  button. Within 3 seconds, rotate the tuning wheel or press  /  buttons to set the desired subaudible tone frequency. After approximately 3 seconds with no change in selection, the display returns to showing the receiver operating frequency (press  button for immediate store).
- 3) Press the  button to display the subaudible tone frequency. With the subaudible tone frequency displayed, press the  button to display (set) ENCode or DECode/ENCode as desired.
- 4) To cancel the subaudible tone, press the  button to extinguish DECode/ENCode.

INTRODUCTION TO SATELLITE OPERATION

The TR270 supports both full duplex, packet data and voice operation through the orbiting amateur satellites.

While most of these satellites travel in polar, low-earth orbits, particular attention must be paid to the antenna system for successful operation. In a polar orbit, as the satellite traverses pole to pole, the earth will rotate below. See Figure 8.

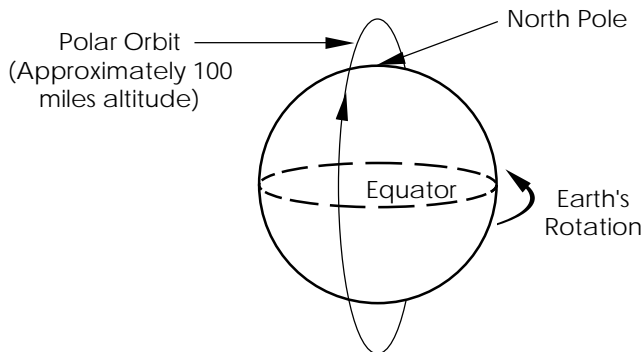

FIGURE 8

This will result in a particular satellite having two "good" passes in a given 24 hour period over a given location. For these "good" passes, simple ground plane type antennas may suffice, although spotty operation due to "nulls" in the antenna's vertical can be expected. See Figure 9.

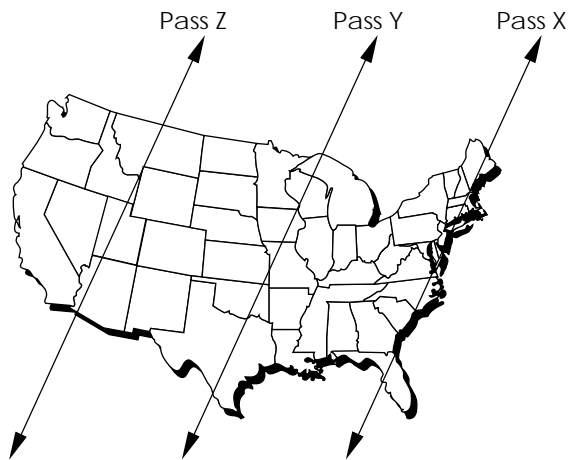

FIGURE 9

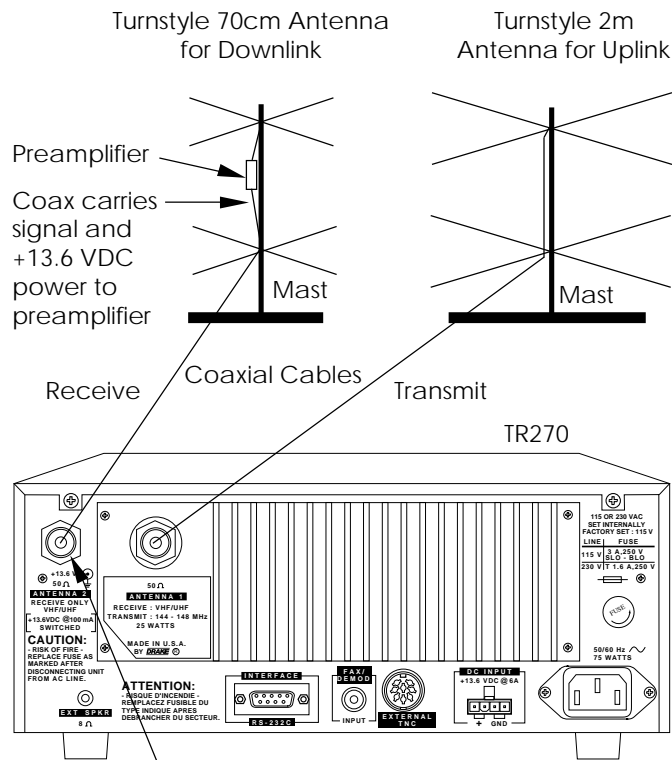
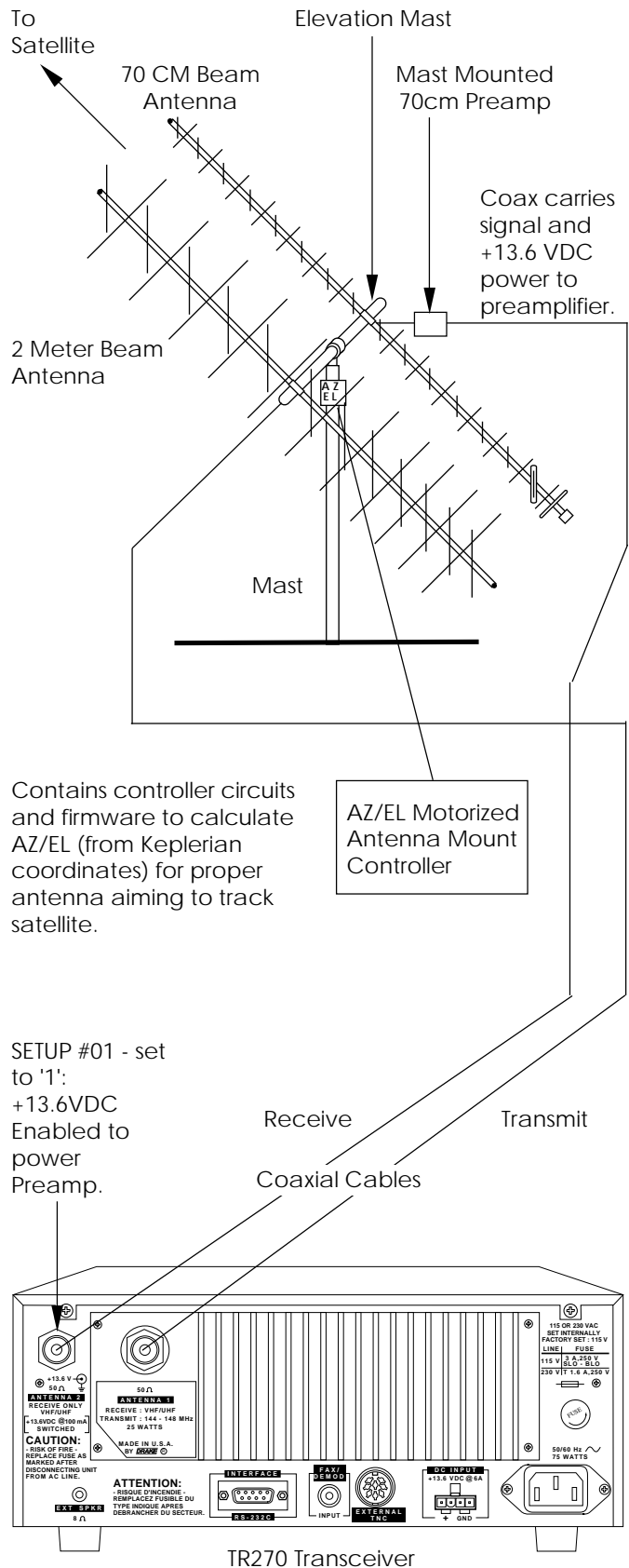

FIGURE 10
 SETUP #01 - set to '1' (turns +13.6 VDC power on to ANTENNA 2)

For serious satellite operation, an antenna tracking system is required. Typically, this type of setup consists of two beam type antennas, one for the uplink (2 meters) and one for the downlink (70 cm). The downlink antenna typically also includes a mast mounted, low noise preamplifier. These antennas are co-located on a common mast to which an elevation rotor is attached. This entire assembly is attached to an additional azimuth rotor. See Figure 11. With this antenna arrangement, complete horizon-to-horizon tracking of the satellite is possible. A PC or other computing device is connected to the elevation and azimuth rotors. The PC runs a program which converts the particular satellite's orbital data (called Keplerian elements, or Keps) and either displays the actual AZ-EL (azimuth-elevation) of the satellite for manual tracking, or directly controls the rotors automatically. For a further, in-depth discussion, refer to AMSAT (Amateur Radio Satellite Corporation) Organization at the following address:

AMSAT
850 Sligo Avenue
Suite 600
Silver Spring, MD 20910

Phone: (301) 589-6062 or <http://www.amsat.org>
on the World Wide Web.



Downloaded by □



Amateur Radio Directory

FIGURE 11

THE AMATEUR SATELLITES - MODES AND FREQUENCIES

As of this printing, there are currently four available amateur satellites which will support communications with the properly configured TR270 transceiver. Three of the four satellites are 9600 BAUD AFSK data types and the fourth supports FM voice operation. The following table outlines the operating frequencies and modes of these satellites.

Table 1:

Satellite	Downlink Frequency (MHz)	Mode	Uplink Frequency (MHz)
UO-22	435.120	FM, 9600 Baud data	145.900 145.975
KO-23	435.175	FM, 9600 Baud data	145.850 145.900
KO-25	435.175	FM, 9600 Baud data	145.870 145.980
	436.500		145.870 145.980
AO-27	436.800	FM, Voice	145.850

There are many other possible satellites to “work” (communicate with) such as the SAREX (Shuttle Amateur Radio Experiment) Space Shuttle, the Russian orbiting space station MIR, etc. The TR270 is factory programmed with most of the common satellite frequencies, as listed by Table 2. A total of 100 satellite memories are available to be programmed as desired. The future should permit a large advancement in amateur satellite operation with the launch of Phase 3D. Refer to AMSAT for the latest details on all of the amateur satellites.

Table 2:

Satellite Channel Memory Number	Satellite	Downlink Frequency (MHz)	Mode	Uplink Frequency (MHz)
00	UO-22	435.120	DATA	145.900
01	UO-22	435.120	DATA	145.975
02	KO-23	435.175	DATA	145.850
03	KO-23	435.175	DATA	145.900
04	KO-25	435.175	DATA	145.870
05	KO-25	435.175	DATA	145.980
06	KO-25	436.500	DATA	145.870
07	KO-25	436.500	DATA	145.980
08	AO-27	436.800	DATA	145.850
09	AO-27	436.800	VOICE	145.850
10	POSAT	435.275	DATA	145.925
11	POSAT	435.275	DATA	145.980
12	FO-29	435.910	DATA	145.870
13	MIR	145.550	DATA	145.550
14	SAREX	145.550	DATA	144.490
15	SAREX	145.550	VOICE	144.910
16	SAREX	145.550	VOICE	144.930
17	SAREX	145.550	VOICE	144.950
18	SAREX	145.550	VOICE	144.970
19	SAREX	145.550	VOICE	144.990





Assuming that the required antenna system is in place to receive the desired satellite, an understanding of how to configure the TR270 for voice and/or data communication through the satellite is required.





DOPPLER FREQUENCY SHIFT CORRECTION



Communication through a satellite requires an understanding of Doppler shift. An example of Doppler shift is the “approaching train” phenomenon. As the train approaches, its horn sound is high in pitch. As the train passes and moves farther away, the pitch of the horn changes to a lower frequency. Similarly, the signal received from the satellite will start at a higher frequency than the published (center) operating frequency as the satellite approaches your location. As the satellite passes over your location and moves farther away, the frequency will change to a value lower than the published (center) operating frequency. To counteract this shift, the TR270 incorporates a method of “locking” onto the satellite’s frequency upon AOS (acquisition of signal) and continuously corrects the receiver frequency throughout the pass until LOS (loss of signal) is encountered. Additionally, the TR270 incorporates a scan range search setting for automatic acquisition of the downlink frequency, a scan pause setting to adjust the rate of scanning, and a scan resume setting to restart a scan if the downlink signal is lost.

FM VOICE OPERATION WITH A SATELLITE

For example, to work the AO-27 satellite: From Table 2, note that Memory Channel 09 selects AO-27 voice frequencies.

1. Enter the SETUP menu and select SETUP #15 = ‘3’. This action will configure the TR270 for separate transceiver ‘A’ and receiver ‘B’ antennas. Also, if using an in-line 70 cm preamplifier, select SETUP #01 = ‘1’ to enable DC power to the ‘ANTENNA 2’ rear panel connector. Press the  button to exit the SETUP menu.
2. Press the  button to enter the satellite mode. The TR270 will display the factory programmed satellite memories. Press the  /  buttons to select memory ‘09’. Refer to Figure 12 on the following page.
3. Press the  button to select the required transmit power level: Low, Medium, or High.

In the Satellite mode, transceiver ‘A’ displays the transmit frequency, and receiver ‘B’ displays the receive frequency. To alter the contents of a particular memory channel, if desired, rotate the tuning wheel or press  followed by numeric frequency entry to tune either transceiver ‘A’ or receiver ‘B’, as selected. Press the  button to select transceiver ‘A’ or receiver ‘B’, as required. To store these new frequencies, if desired, press the  button followed by the  button and enter the desired 2-digit memory number using the numeric buttons (this operation automatically shifts to the NUM mode).

Additionally, the currently displayed frequencies may be copied to the main VFOs in transceiver 'A' and receiver 'B' for use after exiting the SAT mode. With the frequencies displayed in the 'SAT' mode, press the  button followed by the  button.

To exit the SAT mode, at any time, press the  button.

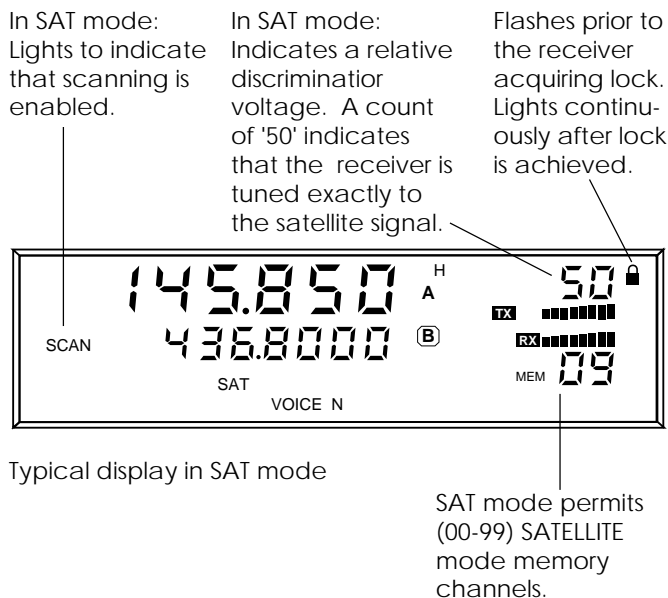







FIGURE 12

Using the desired tracking software (Traksat, Wisp, Instatrak, etc.), a determination of the satellite's position can be calculated. Some programs also indicate the Doppler offset. If the tracking software that is being used has this feature, tune receiver 'B' to the proper frequency using the main tuning wheel.

At this point, note that the upper right MEM indicator has changed to a relative tuning indication. Maintain this number at a count of '50' to keep the receiver centered on the actual downlink frequency of the satellite. As the satellite passes, continue to tune the main tuning wheel to maintain a count of '50'. If the count goes above '50' tune up in frequency. If the count goes below '50', tune down in frequency.

The TR270 defaults to full duplex operation, which permits hearing the transmitted signal on the downlink during transmit on the uplink frequency. If this is annoying, press the  button to toggle receiver 'B' off during transmit.

As mentioned earlier, the TR270 will automatically track the Doppler shift and correct the frequency of receiver 'B'. To enable this feature, once the initial frequency is tuned and a relative tuning indication number between '48' and '52' is displayed, press the  button. The 'SCAN' indicator will illuminate and the upper right  symbol will illuminate continuously. Now, as the downlink frequency changes, the TR270 will automatically tune the frequency of receiver 'B' to track the changing frequency. If the signal fades, a scan will initiate and the receiver will hunt to acquire the carrier again. At this time, the  symbol will flash to indicate a loss of lock on the downlink signal. When the scan sequence acquires the downlink signal, the relative tuning indication will again read '50' and the  symbol will illuminate continuously.

After LOS, the TR270 will begin scanning through a programmed frequency range anticipating the next satellite pass.

The range is programmed within SETUP #53. The indicated number may be set from '00' through '99' (0 to ± 99 kHz, in 1 kHz increments). The factory default setting is '10' (± 10 kHz scanning range of center frequency).

The scan pause time, which is the time between frequency updates, is programmed within SETUP #54. The indicated number may be set from '00' through '99' (0 through 9.9 seconds, in 0.1 second increments). The factory default setting is '05' (0.5 second). The scan resume time, which is the delay time between the end of a satellite locked condition and the resuming of satellite scan, is programmed within SETUP #55. The indicated number may be set from '00' through '99' (0 through 99 seconds, in 1 second increments). The factory default setting is '05' (5 seconds).

9600 BAUD PACKET OPERATION WITH A SATELLITE



Data operation with the PACSATS is slightly more complicated than voice operation, requiring specific software for data communications. A highly recommended software package, available from AMSAT, is the WISP (Windows Satellite Protocol) program. It is a complete turnkey software package specifically designed for PACSAT operation. Refer to AMSAT for additional details. This program processes and places all downloaded data, from a satellite pass, into specific directories.

For example, to work the UO-22 satellite:
From Table 2, note that Memory Channel 00 selects UO-22 data frequencies.





1. Enter the SETUP menu and select SETUP #15 = '3'. This action will configure the TR270 for separate transceiver 'A' and receiver 'B' antennas. Also, if using an in-line 70 cm preamplifier, select SETUP #01 = '1' to enable DC power to the 'ANTENNA 2' rear panel connector. Press the  button to exit the SETUP menu.



If the optional TNC270 is installed,
- Select SETUP #06 = '2' (assigns the internal TNC270 to receiver 'B').
- Select SETUP #07 = '0' (no external TNC).
- OR -

If a properly wired external TNC is installed,
- Select SETUP #06 = '0' (no internal TNC).
- Select SETUP #07 = '2' (assigns external TNC to receiver 'B').
- Select SETUP #08 = '9600' (9600 Baud data).

With the TNC properly installed and assigned,
2. Press the  button to enter the satellite mode. The TR270 will display the factory programmed satellite memories. Press the  /  buttons to select memory '00'. Refer to Figure 13.

3. Press the  button to select the required transmit power level: Low, Medium, or High.

In the Satellite mode, transceiver 'A' displays the transmit frequency, and receiver 'B' displays the receive frequency. To alter the contents of a particular memory channel, if desired, rotate the tuning wheel or press  followed by numeric frequency entry to tune either transceiver 'A' or receiver 'B', as selected. Press the  button to select transceiver 'A' or receiver 'B', as required. To store these new frequencies, if desired, press the  button followed by the  button and enter the desired 2-digit memory number using the numeric buttons (this operation automatically shifts to the NUM mode).

Additionally, the currently displayed frequencies may be copied to the main VFOs in transceiver 'A' and receiver 'B' for use after exiting the SAT mode. With the frequencies displayed in the 'SAT' mode, press the  button followed by the  button.

To exit the SAT mode, at any time, press the  button.

In SAT mode:
Lights to indicate that scanning is enabled.

In SAT mode:
Indicates a relative discriminator voltage. A count of '50' indicates that the receiver is tuned exactly to the satellite signal.

Flashes prior to receiver acquiring lock. Lights continuously after lock is achieved.



Typical display in SAT mode

SAT mode permits (00-99) SATELLITE mode memory channels.

FIGURE 13

Using the desired tracking software (Traksat, Wisp, Instatrak, etc.), a determination of the satellite's position can be calculated. Some programs also indicate the Doppler offset. If the tracking software that is being used has this feature, tune receiver 'B' to the proper frequency using the main tuning wheel.

At this point, note that the upper right MEM indicator has changed to a relative tuning indication. Maintain this number at a count of '50' to keep the receiver centered on the actual downlink frequency of the satellite. As the satellite passes, continue to tune the main tuning wheel to maintain a count of '50'. If the count goes above '50' tune up in frequency. If the count goes below '50', tune down in frequency.

The TR270 defaults to full duplex operation, which permits monitoring the transmitted signal on the downlink during transmit on the uplink frequency. The operation is always full duplex in the data mode.

As mentioned earlier, the TR270 will automatically track the Doppler shift and correct the frequency of receiver 'B'. To enable this feature, once the initial frequency is tuned and a relative tuning indication number between '45' and '55' is displayed, press the  button. The 'SCAN' indicator will illuminate and the upper right (lock) symbol will illuminate continuously. Now, as the downlink frequency changes, the TR270 will automatically tune the frequency of receiver 'B' to track the changing frequency. If the signal fades, a scan will initiate and the receiver will hunt to acquire the carrier again. At this time, the (lock) symbol will flash to indicate a loss of lock on the downlink signal. When the scan sequence acquires the downlink signal, the relative tuning indication will again read '50' and the (lock) symbol will illuminate continuously.

After LOS, the TR270 will begin scanning through a programmed frequency range anticipating the next satellite pass.

The range is programmed within SETUP #53. The indicated number may be set from '00' through '99' (0 to \pm -99 kHz, in 1 kHz increments). The factory default setting is '10' (\pm 10 kHz scanning range of center frequency).

The scan pause time, which is the time between frequency updates, is programmed within SETUP #54. The indicated number may be set from '00' through '99' (0 through 9.9 seconds, in 0.1 second increments). The factory default setting is '05' (0.5 second).

The scan resume time, which is the delay time between the end of a satellite locked condition and the resuming of satellite scan, is programmed within SETUP #55. The indicated number may be set from '00' through '99' (0 through 99 seconds, in 1 second increments). The factory default setting is '05' (5 seconds).

The receiver's front panel display will indicate TNC status, for example: XMT,DCD, etc.

To exit the SAT mode, press the  button.

The TR270 rear panel includes a standard DB-9F connector which conforms to the RS-232C serial data communications standard. The transceiver is configured to be a DCE device. As such, the transceiver may be controlled with a standard dumb terminal or PC running any standard terminal emulation software such as PROCOMM PLUS™, BITCOM™, Windows Terminal Program, etc.

This interface provides for direct control of the transceiver's front panel, including volume and squelch. The front panel controls can be locked out when under computer control by pressing and holding the  button.

Please refer to **FIGURE 14** for individual pin and signal description.

Rear Panel View of TR270 RS-232C Connector

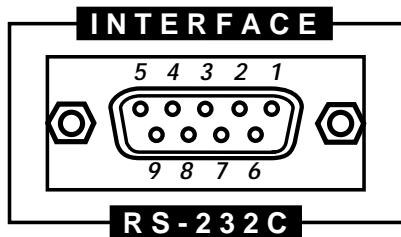

Pin	Function	Signal Description	
1	DCD	Data Carrier Detect	Output
2	TXD	Transmit Data	Output
3	RXD	Receive Data	Input
4	N.C.	No Connection	—
5	GND	Ground	Ground
6	DSR	Data Set Ready	Output
7	RTS	Ready to Send	Input
8	CTS	Clear to Send	Output
9	N.C.	No Connection	—

FIGURE 14 RS-232C Interface Connections

PROCOMM PLUS™ is registered to DATASTORM Technologies, Inc.
 P.O. Box 1471
 Columbia, MO 65205

BITCOM™ is registered to BIT Software, Inc.
 830 Hillview Court, Suite 160
 Milpitas, CA 95035

NOTE:

The following additional items apply when using the RS-232C Interface capability of the transceiver:

FCC WARNING:

SHIELDED INTERFACE CABLES MUST BE USED WITH THIS TRANSCEIVER FOR FCC COMPLIANCE TO LIMITS FOR A CLASS B DIGITAL DEVICE.

When interfacing the transceiver to a computer utilizing a 25 pin male connector for the RS-232C serial port, the following wiring convention should be followed:

Transceiver DB9F Connector	Computer DB25M Connector	Computer DB9M Connector
1	8	1
2	3	2
3	2	3
4	20	4
5	7	5
6	6	6
7	4	7
8	5	8
9	22	9

Note: This equipment has been tested and found to comply with the limits for a Class B digital device, pursuant to Part 15 of the FCC rules. These limits are designed to provide reasonable protection against harmful interference in a residential installation. This equipment generates, uses and can radiate radio frequency energy and, if not installed and used in accordance with the instructions, may cause harmful interference to radio communications. However, there is no guarantee that interference will not occur in a particular installation. If this equipment does cause harmful interference to radio or television reception, which can be determined by turning the equipment off and on, the user is encouraged to try to correct the interference by one or more of the following measures:

- Reorient or relocate the receiving antenna.
- Increase the separation between the equipment and the transceiver.
- Connect the equipment into an outlet on a circuit different from that to which the transceiver is connected.
- Consult the dealer or an experienced radio/TV technician for help and for additional suggestions.

The user may find the following booklet prepared by the Federal Communications Commission helpful: "How to Identify and Resolve Radio-TV Interference Problems." This booklet is available from the U.S. Government Printing Office, Washington D.C. 20402, Stock No. 004-000-00345-4.

Computer Interface with the RS-232C port

1) Before connecting your terminal or PC to the TR270, set the data protocol to 9600 Baud, 8 data bits, no parity, 1 stop bit. Additionally, select Full duplex ON and hardware handshake (RTS/CTS) ON. The connecting cable must provide the RTS and CTS connections in addition to all other required connections as outlined previously in this Computer Control section. If a terminal emulation program such as PROCOM PLUS™ is used, the DIRECT CONNECTION should be chosen rather than MODEM CONNECTION. This will avoid sending modem Init strings to the TR270.

2) Make appropriate connections to the TR270.

3) If the optional TNC270 Packet Data Controller is installed, one of two prompts will be received. If the TNC is not installed (SETUP #06 set for '0'), an ">" will be received as the prompt. If the TNC270 is installed (and SETUP #06 is set for '1' to assign the TNC to transceiver 'A', or set for '2' to assign the TNC to receiver 'B'), the following will be received as the prompt:

```
"R. L. Drake TNC270 Packet Controller"
AX.25 Level 2 Version 2
Copyright © 1986-1996 by
Advanced Electronic Applications, Inc.
Licensed to R. L. Drake Company
Release:
Ver:
```

```
CMD:
```

4) If the TNC270 is installed, a "Radio On" command must be issued at the 'CMD:' prompt in order to control the TR 270. At this point, the ">" prompt will be visible, indicating proper communication to the TR 270. To return to the TNC270 command prompt, enter **'I CR** or **'T CR**.

COMMAND SET

All numbers in these commands are in ASCII. Either upper or lower case is permitted for commands. Commands are only valid in the TR270 states that permit them; there is no difference between local and remote operation in this regard. It is recommended that the keypad be locked while the host PC controls the radio, but the keypad and host can concurrently control the radio operation. It is also recommended that the key-pressed (beep) indication be disabled to reduce annoying noise from the radio during host PC commands. The host communications port should be set to full duplex mode, so the channel can communicate with both the TNC and radio properly. The host should not send ASCII characters in the range 80 to FF hex. Characters in the range E0 to FF hex are reserved for internal radio use, and the other "8-bit characters" are not recognized.

Any errors in syntax will result in an error indication sent to the host, which consists of bell and "!" characters. Any errors in misplaced operation (commands not proper for the current radio mode/state) will result in an error beep locally, just as an improper button pressed on the front panel keypad. The TR270 will return the prompt ">" after each command is parsed.

Any whitespace character (space, tab, vertical tab, formfeed, carriage return, or linefeed) can be used to terminate a command. The block write ("Lx") commands are fixed-length and require termination. All other commands are self-terminating, but any whitespace character can be used to terminate these commands before optional digits. This action will permit filling in the remaining unspecified frequency digits with zeroes, for example. The symbol "[]" brackets used in the charts of this section designate placeholders for the syntax of the block commands and optional numbers in the select commands.

Most commands are intuitive, but some require explanation. The "T" command will permit the host to talk to the internal TNC (if installed). When the host is talking to the TNC, the "RADIO ON" command can be issued to permit the host to talk to the radio again. VFO scanning, memory channel scanning, and priority watch can be cancelled for a selected receiver by entering VFO, memory channel, or priority states (commands 'V', 'C', or 'W'). The 'V' command will toggle the active VFO if the transceiver is in the VFO state, unless the receiver is VFO scanning or in the priority watch mode. The 'H' command will step the frequency or memory channel in the direction that was last set by the 'U' or 'D' commands, or by the tuning wheel. The 'G' and 'N' commands control and set volume and squelch, respectively. Setting volume level '99' results in maximum volume. Setting the squelch to '99' results in full squelch ('00' is the no squelch setting). Thus '00' corresponds to the full CCW setting of the respective front panel control, and '99' corresponds to the full CW setting of the control.

The unused command characters are "JYZ". The help command ('?') displays the following table of computer interface commands:

Select Commands (Listed in alphabetical order by COMMAND)

FUNCTION	COMMAND	DESCRIPTION
autopatch B bandwidth memory channel memory channel lock freq/ch step, scan dir	Ax Bx C [xx] Cx D/U	x = 0-9 (DTMF phone number) x = N, W (implies entry into mem state) x = U, L (also sets handwheel direction)
set frequency volume/squelch control remote volume level handwheel freq/ch step init	Fxxx [xxxx] Gx Gxyy H Ix	(in current vfo; zero filled) x = Y, N (yes - remote, no - radio controls) x = A, B (receiver), yy = level (00 - 99) (direction can be overridden by handwheel!) x = C, S (memory channels, setup defaults)
keypad/handwheel lock mode volume/squelch control remote squelch setting transmit offset	Kx Mx Nx Nxxy Ox	x = U, L x = V, D, S, W (voice, data, standby, wxsat) x = Y, N (yes - remote, no - radio controls) x = A, B (receiver), yy = setting (00 - 99) x = S, P, M, V (simplex, +, -, variable/odd)
xmit power cts action cts subaudible freq receiver scan	Px Qx Qxx Rx Sx	x = L, M, H x = N, E, B, D (none, enc, both enc/dec, dec) xx = freq table index (00 - 46) x = A, B x = V, C (vfo, memory channels)
select TNC freq/ch step, scan dir vfo priority channel watch xmit/rx reverse	T U/D V [x] W [x] Xx	(host now talks to internal TNC) (also sets handwheel direction) x = 1, 2 (implies entry into vfo state) x = Y, N (implies entry into priority state) x = Y, N

Block Commands

enquire (read)	Ex [d] [y[y]]	x = commands S, C, L, B, D, W, F, G, I d = designator of A, B, W, [s] for 'C', 'W' cmds. y = number
load (write)	Lx [d] [y[y]] = zt	x = commands S, C, D, W, d = designator of A, B, W, [S] for 'C', 'W' cmds. y = number z = data value or string t = command termination character
where: S-setup, c-memory channel, L-LCD segments, B-LCD blinking segments, D-DTMF phone number, W-priority channel, F-current frequency, G-signal strength meter, I-version ID.		

Note that the following select commands act on the currently selected receiver (A or B): 'C', 'D', 'F', 'H', 'M', 'Q', 'S', 'U', 'V', and 'W'.

Note that if a number is not specified in the block read command, ALL data is reported to the host. For example ES<CR> will report ALL active setup functions and settings, one function/setting per line. Otherwise, "ES" requires a two-digit number to specify a particular setup function. "ES", "EC", "EL", and "EB" commands require two-digit numbers, where "ED" requires a one-digit

number. The remaining commands do not permit any number. The range of two-digit numbers for the "EL" and "EB" commands is '00' to '26'. "EF" and "EG" act on the currently selected receiver (A or B).

The designators 'A', 'B', 'W', and 'S' correspond to receiver A, receiver B, weather sat, and sat respectively. There are 100 memory channels for each of these designations. There is no priority channel in the sat state, therefore "EWS" is an invalid command.

The block write commands follow the same logic, and the data value or string sent in the command is identical to the report format of the block read command.

Example report formats (defaults) and commands follow:

Read Command	Report Format	Write Command
ES01	01=0	LS01=1<CR>
ES08	08=1200	LS08=9600<CR>
ES23	23=4700000	LS23=4700000<CR>
ES40	40=--, --, --, --, --, --, --, --, --, --	LS40=11, 22, 33, 44, 55, 66, 77, 88, 99, --<CR>
ECA59	A59=UV147180N00P146595	LCA59=UV147180N00P146595<CR>
ECB59	B59=UV1605900N00	LCB59=UV1605900D12<CR>
ECW59	W59=UV1375900	LCW59=1375900<CR>
ECS59	S59=UV4351750, 145590	LCS59=UV4351750, 145590<CR>
ED3	3=- - - - -	LD3=#*1234567890AB<CR>
EWA	A=V145490E12M	LWA=V145490E12M<CR>
EWB	B=V1450000N00	LWB=V1450000D25<CR>
EWV	W=V1376200	LWV=V1376200<CR>
EL04	B5	
EB06	00	
EF	A1=V145190N00M or B1=V1624750N00 or memory channel report (ECA/B/W/S) or priority report (EWA/B/W)	
EG	A65 or B65	
EI	TR270 Version 1.0	

Note that '-' can be used in "LD" and "LS4x" commands to specify unused digits or memory channels. The valid digits in the "LD" command are 0-9, A-D, '#', and '*'.

For memory channel reports/commands, the first character is the channel status (U - unlocked, or L - locked), the second character is the channel mode (V - voice, D - data), followed by the receive frequency.

- For receiver A, the CTCSS status (N - none, E - encode, or B - both), the CTCSS index (00 - 46) and the transmit offset (S - simplex, P - plus, M - minus, or V - variable) follows the frequency. The transmit frequency is reported last for receiver A (variable offset) and sat (uplink) channels. A valid variable offset transmit frequency must be specified even if the offset is not 'V', for the "LCA" command.

- For receiver B, the CTCSS status (N - none or D - decode) and CTCSS index follow the frequency.

The priority channels specify mode (V or D) and frequency.

-Receiver A also requires CTCSS status (N, E, or B), CTCSS index, and transmit offset (S, P, or M).

-Receiver B requires the CTCSS status (N -none or D-decode) and CTCSS index.

The report for the "EF" command shows either the active VFO, memory channel, or priority channel report. The VFO report includes the receiver (A or B), the current VFO (1 or 2), ('='), the mode (V, D, S, or W), the frequency, CTCSS status, and CTCSS index. Receiver A also shows the transmit offset (S, P, M, or V).

The "EL" and "EB" commands are provided for displaying the LCD (preferably graphically) on the host PC using software written by the user.

TO SAVE A REPORT

For example, using PROCOMM PLUS™, the report can be saved as an ASCII file:

- 1) Enter the log filename (CR for default): REPORT.log
- 2) Open the log file.
- 3) Start entering the report commands as desired.
- 4) Close the log file, by pressing Alt, F1.
- 5) To edit any entries, using WordPerfect® for example, alter the report formats to be Write (Load) commands formats at each entry.
- 6) Load the (edited) file to the TR270 by pressing Page Up and then typing in the name of the file with the path. Press Enter to start the data loading.

DATA OPERATION

The TR270 FM Transceiver has been designed for superior performance with 1200 and 9600 BAUD Packet Radio data rates in addition to its quality FM voice operation.

The optional TNC270 is a single, plug-in Terminal Node Controller module for the TR270 which contains both 1200 and 9600 BAUD modems. The module also contains on-board, battery backed static RAM for Mailbox messages. When installed, it offers a turn-key packet station for both terrestrial and satellite modes of operation. In addition to the hardware, the TNC270 is supplied with two software packages: *PC PAKRATT* for MSDOS™, and *PC PAKRATT* for Microsoft Windows™. These programs are designed to fully exploit the entire TNC270 command set under either operating system.

The features include:

- AX.25 Level 1 & 2, 1200/9600 BAUD Packet operation in Command, Host, and KISS modes
- 18 KB Mailbox
- Node operation
- Hardware state machine for "true DCD" open squelch operation
- Hardware HDLC controller guarantees accurate protocol conversion at 9600 BAUD
- Modem disconnect header for installing other modems
- Separate 1200/9600 BAUD transmit level controls
- Enhanced MHEARD function identifies TCP/IP, NET/ROM, and <THE-NET> stations
- Expert command included to ease the learning process - only the most common commands will be used until the EXPERT mode is enabled.
- Independent Operation: once installed and configured, the TNC270 will independently accept connects, receive and forward mail, and act as a node while the TR270 remains powered on.

Please refer to the Installation/Operating manual provided with the TNC270 for complete installation and operating instructions.

- Book for Windows™ software.

(The DOS software is explained in a Read Me file on the supplied diskette).

FAX OPERATION

The optional DEMOD270 Multimode Demodulator, when installed in the TR270 FM Transceiver, allows both AM and FM demodulation of various data transmissions. The DEMOD270 is user installable and includes a complete suite of PC based software. The features are as follows:

1) Decodes the following data transmissions in the FM mode:

- HF radio facsimile
- Morse Code
- RTTY (Radio Teletype)
- FEC/NAVTEX
- ACARS (Aircraft Communications and Reporting System)

2) Decodes the following data transmissions in the AM mode:

- NOAA APT Weather Satellite
- GOES WEFAX (If used with an external 1691 MHz to 137.5 MHz converter)

Please refer to the Installation/Operating Manual that is included with the DEMOD270 for complete installation and operating instructions.

- Book for FAX software.

- Book for ACARS software.

1) The ARRL Antenna Book

Published by:

The American Radio Relay League

225 Main Street

Newington, CT 06111 U.S.A.

Copyright © 1988 by The American Radio Relay League

Library of Congress Catalog Card Number: 55-8966

2) The ARRL Handbook

Published by:

The American Radio Relay League

225 Main Street

Newington, CT 06111 U.S.A.

Copyright © 1989 by The American Radio Relay League

Library of Congress Catalog Card Number: 41-3345

3) Your VHF Companion

Published by:

The American Radio Relay League

225 Main Street

Newington, CT 06111 U.S.A.

Copyright © 1992-96 by The American Radio Relay

League

ISBN: 0-87259-387-8



4) AMSAT































850 Sligo Avenue

Suite 600

Silver Spring, MD 20910 U.S.A.

- 1) **AMSAT** - Amateur Satellite Corporation which designs, builds and coordinates the launching of amateur communication satellites.
- 2) **AOS** - Acquisition of signal.
- 3) **ack** - Acknowledge - Sending data to confirm the receipt of other data that was initially sent.
- 4) **AC Input** - Alternating current power source available at wall outlet sockets.
- 5) **AGC** - Automatic Gain Control which is employed in receivers to adjust the amount of gain in the receiver's circuitry to prevent distortion and maintain a nearly constant audio volume level over wide variations in received signal strength.
- 6) **Bird** - Satellite.
- 7) **Call** - Call sign which identifies a particular amateur radio operator.
- 8) **Ctrl** - Control character sent from personal computer or terminal keyboard.
- 9) **DCD** - Data Carrier Detect
- 10) **DC Input** - Direct Current power source such as is available from batteries or regulated power supplies. Lead acid storage batteries, such as employed in cars and boats, have a 12-14 volt DC output which is the proper operating voltage for the transceiver's DC input. Another requirement of the battery is its AMP-HR rating. To determine the number of hours of operation before battery recharging is required, divide the AMP-HR rating of the battery by (2 AMPS) the current requirement of the transceiver (assuming a duty cycle of 1 minute transmit at 6 Amps and 4 minutes receive at 1 Amp).
- 11) **Downlink** - The frequency from a satellite to a ground station.
- 12) **Esc** - Escape character sent from personal computer or terminal keyboard.
- 13) **Frequency** - Rate of reoccurrence in Hertz or cycles/second of an electromagnetic wave or carrier.
- 14) **FM** - Frequency Modulated signals, in which the information or intelligence being transmitted, changes the instantaneous frequency of the transmitter carrier. Not to be confused with the FM Broadcast Band (FM frequencies of 88 to 108 MHz).
- 15) **FSK** - Frequency Shift Keying is a method of encoding a signal by using constant-amplitude radio frequency pulses having different frequencies, one frequency for each of the possible message symbols.
- 16) **LF** - Line feed control character sent to start a new line of message or printing.
- 17) **LCD -Liquid-Crystal Display** - composed of two parallel glass plates with conductive coatings sandwiching a liquid-crystal compound between them. The compound becomes opaque and reflective when subjected to an electric field. LCD displays are used as information displays on many types of electronic equipment.
- 18) **LOS** - Loss of signal.
- 19) **mS** - millisecond, 1/1000 of a second.
- 20) **PACSAT** - Packet (data) satellite.
- 21) **PC** - Personal computer.
- 22) **PTT** - Push to talk, refers to the push operated switch on a microphone attached to a transmitter.
- 23) **RF** - Radio frequency.
- 24) **RS-232C** - Electronics Industries Association standard physical-level interface between DTE (terminal) and DCE (modem).
- 25) **RTTY** - Radio Teletype communications.
- 26) **Squelch** - A user controlled adjustment which mutes the audio output for received signals that are below a certain strength.
- 27) **Synthesized** - Capable of generating a large number of different output frequencies, all related to a single, highly stable reference source.
- 28) **TNC** - Terminal Node Controller, used for the transmission and reception of packet data through a communications link.
- 29) **UHF** - Ultra High Frequency band extends from approximately 300 MHz to 3000 MHz.
- 30) **VFO** - Variable Frequency Oscillator.
- 31) **VHF** - Very High Frequency band extends from approximately 30 MHz to 300 MHz.

Most front panel pushbuttons perform two functions. The second function requires that the  button be pressed first, and then the desired second function button pressed within three seconds. The symbol  indicates that the button is to be pressed within three seconds.

Enter SETUP (page 14) -----	Press and hold  .
Assign antenna inputs (page 16) -----	Press and hold  . Rotate tuning wheel to #15. Press  to set 0, 1, 2, or 3.
Select Transceiver 'A' or Receiver 'B' (page 7) -----	Press  .
Select VFO (page 7) -----	Press  .
Adjust Frequency (pages 6, 7, 13) -----	Turn tuning wheel, Press  buttons, or Press   numeric buttons.
Set tuning wheel step size (pages 13, 15) -----	'A': Press and hold  . Rotate tuning wheel to #04. Press  to set 5, 10, 15, 20 or 25 kHz. 'B': Press and hold  . Rotate tuning wheel to #05. Press  to set 5, 10, 12.5, 15, 20, or 25 kHz.
Select Mode (page 7) -----	'A': Press  to select VOICE, DATA, or Standby. 'B': Press  to select VOICE, DATA, WXSAT, or Standby.
Select Priority (page 7) -----	Press  for selected receiver frequency to be priority. Press and hold  to initiate priority watch (PW lights).
Set Priority Channel Action (page 14) -----	Press and hold  . Rotate tuning wheel to #02. Press  to set 0 or 1.
Set transmit power (page 18) -----	Press and hold  . Rotate tuning wheel to #50 (Low), #51 (Medium), or #52 (High). Press  to set level.
Select relative transmit power (page 7) -----	Press  .
Set time-out-timer for transmit (page 16) -----	Press and hold  . Rotate tuning wheel to #14. Press  to set 0 (no time out), 1, 2, 3, or 10 minutes.
Select IF Bandwidth for Receiver 'B' (page 7) -----	'B' only: Press  .
Lock (Unlock) Controls (page 7) -----	Press  for selected transceiver 'A' / receiver 'B'.
Set LCD backlight intensity (page 19) -----	Press and hold  . Rotate tuning wheel to #56. Press  to set intensity.
Set Audible Beep On or Off (page 16) -----	Press and hold  . Rotate tuning wheel to #12. Press  to set 1 (beep on) or 0 (beep off).
Set Transmit Microphone audio filter On or Off (page 19) -	Press and hold  . Rotate tuning wheel to #58. Press  to set 1 (filter on) or 0 (filter off).

MEMORY FUNCTIONS

Storing to VFO (page 20) -----

Programming Priority Channel (page 20) -----

Memory Channel Programming (pages 20, 21) -----

Recalling a Memory Channel (page 20) -----

Changing a Memory Channel (page 20) -----

Construct a Memory List (page 20) -----

Locking a Memory Channel (page 21) -----

Restore Factory Memory Programming (page 21) -----

Restore Factory Setup Settings (page 21) -----

SCAN FUNCTIONS

Program the Scan (Stop) method (pages 16, 22 - 26) -----

- Stop scan at first detected carrier; exit scan -----

- Stop scan at detected carrier; resume (5) seconds after carrier drops. -----

- Stop scan at detected carrier; wait (5) seconds; resume scan. -----

- Stop scan at detected carrier; resume scan immediately after carrier drops. -----

Scan Memory (pages 16, 22 - 26) -----

Program to scan ALL memory channels -----

Program to scan a RANGE memory channels -----

With a desired frequency displayed,

Press 3 to store into VFO, or

Press 3 to store into priority, or

Press 3 for a flashing memory number indication. Enter a 2-digit number.

From the VFO or Priority mode, Press . Enter 2-digit memory number. In the memory mode, rotate tuning wheel or Press for selection.

Store a new channel to old location (erases original information).

Press and hold .

'A': Rotate tuning wheel to SETUP #30 (through 39). Press

for 0-9 index within a list. Enter a 2-digit memory channel number at each desired index. Advance the index, enter the next 2-digit memory channel number until list is complete. Advance to next Setup number (rotate wheel) if additional lists are to be programmed.

'B': Same as 'A', except use SETUPS #40-49.

With the desired memory number displayed, Press (lock '🔒' symbol lights).

With power off, Press and hold while turning the TR270 power switch on.

With power off, Press and hold .

Press and hold . Rotate tuning wheel to SETUP #16, 17, 18, or 19 as required.

Press to set for '0', or

Press to set for '1', or

Press to set for '2', or

Press to set for '3'.

Press and hold .

'A': Rotate tuning wheel to #24. Press to set '0'.

'B': Rotate tuning wheel to #27. Press to set '0'.

'A': Rotate tuning wheel to #24. Press to set '1'.

Rotate tuning wheel to #25. Enter 2-digit start number.

Rotate tuning wheel to #26. Enter 2-digit stop number.

'B': Rotate tuning wheel to #27. Press to set '1'.

Rotate tuning wheel to #28. Enter 2-digit start number.

Rotate tuning wheel to #29. Enter 2-digit stop number.

Program to scan a List of Memory Channels (pages 24, 25)

'A': Rotate tuning wheel to #24. Press / to set '2'.
(construct List in SETUPS #30-39, if necessary) Exit SETUP.
Press and hold for flashing prompt. Enter desired list number, 0 - 9 (as programmed in SETUPS #30-39).

'B': Rotate tuning wheel to #27. Press / to set '2'.
(construct List in SETUPS #40-49, if necessary) Exit SETUP.
Press and hold for flashing prompt. Enter desired list number, 0 - 9 (as programmed in SETUPS #40-49).

Program to scan VFO (pages 16, 17, 25, 26) -----

Press and hold .

'A': Rotate tuning wheel to #20. Enter the START frequency endpoint (144 - 148 MHz).
Rotate tuning wheel to #21. Enter the STOP frequency endpoint (144 - 148 MHz).

'B': Rotate tuning wheel to #22. Enter the START frequency endpoint (136 - 174 MHz, 420 - 470 MHz).
Rotate tuning wheel to #23. Enter the STOP frequency endpoint (136 - 174 MHz, 420 - 470 MHz).

Start Scan (pages 7, 23-26) -----

Set the squelch control to quiet the receiver. Press and hold either or , as desired, to start the scan.

Stop Scan (pages 7, 23-26) -----

During scan, press , , or . For transceiver 'A' only, keying PTT also stops the scan.

OPERATION WITH REPEATERS

Set Repeater Offsets (pages 27, 28) -----

Press , to select '+', '-', or Simplex.

CONFIGURE UNIT TO OPERATE AS A REPEATER

(pages 16, 29, 30)

Set for Normal or Repeater Mode (page 16) -----

Press and hold . Rotate tuning wheel to SETUP #13.

Press / to set '0' (normal) or '1' (repeater).

Set repeater mode highpass audio filter On or Off (pages 19, 30) -----

Press and hold . Rotate tuning wheel to SETUP #57.

Press / to set '0' (filter off) or '1' (filter on).

SUBAUDIBLE TONE

Set Transceiver 'A' subaudible tone filter On or Off (pages 19, 28) -----

Press and hold . Rotate tuning wheel to SETUP #59.

Press / to set '0' (filter off) or '1' (filter on).

Set Receiver 'B' subaudible tone filter On or Off (pages 19, 28, 30) -----

Press and hold . Rotate tuning wheel to SETUP #60.



Press / to set '0' (filter off) or '1' (filter on).



Program Subaudible Tone Frequency (pages 28, 30) -----

'A': Press rotate tuning wheel or press / to set desired tone frequency.

'B': Press rotate tuning wheel or press / to set desired tone frequency (or 'OFF' for no tone).

Enable/Disable Tone (page 7) -----

'A': Press  once to display current CTCSS tone frequency. Press  a second, third and fourth time **3** → press  to select 'ENC', 'DEC/ENC', or no tone on transmit or receive as required.



'B': Press  once to display current CTCSS tone frequency.
Press  a second and third time to enable or disable ('OFF') the tone decoding as required.

DTMF Dialing

Use DTMF tones (page 28) -----

Press push-to-talk on microphone. Press 0-9, A-D, *,# as required to dial the phone number.

To Store a Phone Number (page 29) -----

Press  **3** → Press 0-9 to select a memory location. Enter the phone number. Press  to store the number.

To Dial a Phone Number from Memory (page 29) -----

Press  **3** → press 0-9 to select desired memory location. Press PTT to transmit DTMF tones.

-OR-

Press  **3** → press PTT to transmit. Press 0-9 to select desired memory location (DTMF tones will be transmitted).

Lined paper area with 30 horizontal lines.

SERVICE INFORMATION

You may contact R. L. DRAKE Service Department for additional information or assistance by calling (513) 746-6990, Monday through Friday, 8:00 A.M. - 5:00 P.M. EST, except on holidays.

You may also contact the R. L. DRAKE Service Department by E-mail at the following address:
 service@rldrake.com
 or by Telefax:
 +1 (513) 743-4576.

Should you want to return your unit for service, package the transceiver carefully using the original carton or other suitable container.

Write your return address clearly on the shipping carton and on an enclosed cover letter describing the service required, symptoms or problems. Also include your daytime telephone number and a copy of your proof of purchase.

The transceiver will be serviced under the terms of the R. L. DRAKE Company Limited Warranty and returned to you.

IF YOU NEED TO CALL FOR HELP

Call our Customer Service/Technical Support line at (513) 746-6990 between 8:00 a.m. and 5:00 p.m. EST, weekdays. Please have the unit's serial number available. We will also need to know the specifics of any other equipment connected to the unit.

When calling, please have the unit up and running, near the phone if possible. Our technician(s) will likely ask certain questions to aid in diagnosis of the problem. Also, have a voltmeter handy, if possible.

R. L. DRAKE also provides technical assistance by e-mail: bill_frost@rldrake.com
 or by Telefax: +1 (513)-743-4576.

Many of the products that are sent to us for repair are in perfect working order when we receive them. For these units, there is a standard checkout fee that you will be charged. Please perform whatever steps are applicable from the installation sections of the Owner's Manual before calling or writing—this could save unnecessary phone charges. Please do not return the unit without contacting R. L. DRAKE first: it is preferred to help troubleshoot the problem over the phone (or by mail) first, saving you both time and money.

Inside the carton, enclose a note with your name, address, daytime phone number, and a description of the unit's problem.

The unit must be sent to the following address:

Service Department
 R. L. DRAKE COMPANY
 230 Industrial Drive
 Franklin, Ohio 45005 U.S.A.

Be sure to include your street address which will be needed for UPS return. UPS Surface (Brown Label) takes 7-10 days to reach us depending on your location, Blue takes 2-3 days.

Red is an overnight service and is expensive. Send the unit in a way that it can be traced if we can't verify receipt of shipment. We suggest UPS or insured postal shipment.

If the unit is still under the original owner's warranty, R. L. DRAKE will pay the cost of the return shipment to you. Our return shipping policy is that we will return it UPS Brown if received Brown or by US Mail, it will be returned Blue if received Blue or Red—or it will be returned however you prefer if you furnish the return cost for the method you select.

If the unit is out of warranty, it will be returned by UPS Brown label COD unless:

- 1) It was received UPS Blue/Red, in which case it will be returned UPS Blue/Red COD;
- 2) You designate billing to American ExPress, VISA, MasterCard or Discover card;
- 3) You prepay the service charges with a personal check, or
- 4) You specify some other method of return.

When calling, the technician can estimate the repair charges for you over the phone. This is another good reason to call before sending a unit in for repair.

Typically, equipment is repaired in five to ten working days after it arrives at R. L. DRAKE if we have all the facts. If we must call you, it may take longer. R. L. DRAKE is not responsible for damage caused by lightning, nonprofessional alterations, "acts of God", shipping damage, poor storage/handling, etc. R. L. DRAKE will make note of any shipping damage upon receipt.

Should your warranty card not be on file at R. L. DRAKE, you will need to send proof of purchase to receive warranty service. Typically, a copy of the invoice from an R. L. DRAKE dealer will suffice. The warranty is for the original owner only and is not transferable.

One Year Limited Warranty

R.L.DRAKE COMPANY warrants to the original purchaser this product shall be free from defects in material or workmanship for one (1) year from the date of original purchase.

During the warranty period the R.L.DRAKE COMPANY or an authorized Drake service facility will provide, free of charge, both parts and labor necessary to correct defects in material and workmanship. At its option, R. L. Drake Company may replace a defective unit.

To obtain such warranty service, the original purchaser must:

- (1) Complete and send in the Warranty Registration Card within 10 days of purchase.
- (2) Notify the R.L.DRAKE COMPANY or the nearest authorized service facility, as soon as possible after discovery of a possible defect, of:
 - (a) the model and serial number,
 - (b) the identity of the seller and the approximate date of purchase; and
 - (c) A detailed description of the problem, including details on the electrical connection to associated equipment and the list of such equipment.
- (3) Deliver the product to the R.L.DRAKE COMPANY or the nearest authorized service facility, or ship the same in its original container or equivalent, fully insured and shipping charges prepaid.

Correct maintenance, repair, and use are important to obtain proper performance from this product. Therefore carefully read the Instruction Manual. This warranty does not apply to any defect that R.L.DRAKE COMPANY determines is due to:

- (1) Improper maintenance or repair, including the installation of parts or accessories that do not conform to the quality and specifications of the original parts.
- (2) Misuse, abuse, neglect or improper installation.
- (3) Accidental or intentional damage.

All implied warranties, if any, including warranties of merchantability and fitness for a particular purpose, terminate one (1) year from the date of the original purchase.

The foregoing constitutes R.L.DRAKE COMPANY'S entire obligation with respect to this product, and the original purchaser shall have no other remedy and no claim for incidental or consequential damages, losses or expenses. Some states do not allow limitations on how long an implied warranty lasts or do not allow the exclusions or limitation of incidental or consequential damages, so the above limitation and exclusion may not apply to you.

This warranty gives you specific legal right and you may also have other rights which vary from state to state. This warranty shall be construed under the laws of Ohio.

For service information contact:

Service Department
R.L. DRAKE COMPANY
230 Industrial Drive
Franklin, Ohio 45005 U.S.A.

Customer Service Center Phone: +1 (513) 746-6990
TELEFAX: +1 (513) 743-4576
WORLD WIDE WEB SITE: <http://www.rldrake.com>



R.L. DRAKE COMPANY
230 INDUSTRIAL DRIVE
FRANKLIN, OHIO 45005 U. S .A.
CUSTOMER SERVICE AND PARTS TELEPHONE:
+1 (513) 746-6990
TELEFAX:
+1 (513) 743-4576
WORLD WIDE WEB SITE:
<http://www.rldrake.com>

Downloaded by

Amateur Radio Directory