

# EICO

## 753/Tri-Band SSB/AM/CW Transceiver



# OPERATING MANUAL

## GENERAL DESCRIPTION

The EICO Model 753 SSB/AM/CW Transceiver incorporates a filter type single sideband transmitter and a single conversion superheterodyne receiver for operation on the 80, 40 and 20 meter amateur bands. It is equally suited for mobile and fixed station use.

In fixed station use, the Model 751 AC Supply/Speaker Console (117 VAC, 60 cps) is required for its operation. In mobile use, the Model 752 DC Supply (12 VDC, positive or negative ground) is required. Both supplies have been designed integrally with the 753 and provide the requisite filtering and regulation. They can not be supplanted by supplies of other manufacture if the design capabilities of the 753 are to be obtained.

### FEATURES

### SPECIFICATIONS

o Full band coverage on 80, 40 and 20 meters. o Receiver offset tuning (up to  $\pm 10$ kc) without altering transmitter frequency. o Built-in VOX. o Panel selected VOX, PTT & STANDBY. o High level dynamic ALC to prevent flat-topping or splatter and permit the use of a linear amplifier. o Automatic carrier level adjustment on CW and AM. o Dual ratio ball drive permits single knob 6:1 rapid tuning and 30:1 fine tuning (over 10 degrees of scale). o Position of hairline adjustable on panel. o Illuminated S-meter/PA Cathode Current Meter and tuning dial. o Fast attack, slow decay AGC. o Grid-block break-in CW keying. o Product detector for SSB and CW, triode detector for AM. o TR relay with auxiliary contacts for use with high power linear amplifier. o Includes mobile mounting bracket.

### ADDITIONAL SPECIFICATIONS

FREQUENCY COVERAGE: 3490-4010kc, 6990-7310kc, 13890-14410kc. SSB EMISSIONS: LSB 80 and 40 meters, USB 20 meters. RF POWER INPUT: 200 watts SSB PEP and CW, 100 watts AM. RF POWER OUTPUT: 120 watts SSB PEP and CW, 30 watts AM. OUTPUT PI NETWORK MATCHING RANGE: 40-80 ohms. SSB GENERATION: 5.2 Mc crystal lattice filter; bandwidth 2.7kc at 6db. STABILITY: 400 cps after warm-up. SUPPRESSION: Carrier-50db; unwanted sideband-40db. RECEIVER: Sensitivity 1uv for 10db S/N ratio; selectivity 2.7kc at 6db; audio output over 2 watts (3.2 ohms). PANEL CONTROLS & CONNECTORS: Tuning, Band Selector, AF Gain, RF Gain, MIC Gain with calibrator switch at extreme CCW rotation, Hairline Set (capped), Mode (SSB, AM, CW, Tune), Function (Off, Standby, PTT, VOX), Carrier Balance, Exciter Tune, PA Tune, PA Load, Receiver Offset Tune, MIC input, phone jack. REAR CONTROLS & CONNECTORS: VOX Threshold, VOX delay, VOX sensitivity, Anti-VOX sensitivity, PA Bias adjust, S-Meter zero adjust, power socket, external relay, antenna connector, key jack, accessory calibrator socket. METERING: PA cathode on transmit, S-Meter on receive. SIZE (HWD): 5-13/16" x 14-1/4" x 11-1/4". POWER REQUIREMENTS: 750 VDC at 300ma, 250 VDC at 170ma, -100 VDC at 5ma, 12.6 VAC at 3.8 amps.

## INSTALLATION PROCEDURES

### WARNING

LETHAL HIGH VOLTAGES ARE PRESENT WITHIN THIS EQUIPMENT. BE VERY CAREFUL TO AVOID CONTACT WITH THESE HIGH VOLTAGES IF FOR ANY REASON THE EQUIPMENT IS OPERATED OUTSIDE OF ITS CABINET.

## UNPACKING

This equipment has been thoroughly tested and inspected before packing. If you find visible damage upon unpacking, notify the dealer at once. If the unit was shipped, you must file a claim with the carrier, since only you can recover for shipping damages. Your dealer and EICO will cooperate.

## VENTILATION

In all installations, consideration should be given to adequate ventilation in placing the unit. Free air circulation through the perforated cabinet should not be obstructed at any time. If heat removal by convective air movement is prevented or curtailed by cabinet obstruction, an excessive temperature rise will occur which can damage components. In any installation, avoid placing the unit in a warm location (near a radiator or heating unit) or in a hot air stream.

## ANTENNAS

A suitable antenna, presenting 40 to 80 ohms resistive load should be connected to the ANTENNA connector at the rear. Install the antenna as recommended by the antenna manufacturer. A type PL259 connector is required for coupling the antenna cable to the ANTENNA connector. In mobile installations, the antenna may be mounted on the trunk lid, or on a rear fender. Note that a mobile antenna tuned to resonance may have a radiation resistance below the 40-80 ohm matching range provided by the 753. In this case, it will be required to introduce additional capacitance across the antenna cable, preferably at a point in the antenna cable close to where it connects to the transceiver.

## EXTERNAL RELAY CONTROL TERMINALS

The EXTERNAL RELAY control terminals 1 and 2 at the rear comprise a SPST switch (rated at 1 ampere) to permit control of accessory equipment, in conjunction with selection of transmit or receive operation. Terminal 1 is chassis ground; terminal 2 is floating during receive, and connected to terminal 1 during transmit.

For example, a DPDT coaxial relay (or a pair of SPST coaxial relays) connected to EXTERNAL RELAY terminals 1 and 2 may be used to enable operation of a high power linear amplifier with the Model 753. The required connections are shown in Fig. 1, including an additional SPST switch to permit either low power "straight-through" operation with the Model 753 or high power operation with the linear.

## MOBILE MOUNTING

The mobile mounting bracket supplied permits the unit to be installed underneath the automobile dashboard, and locked in place in the most suitably angled position for convenient operation. Furthermore, the unit may easily be released and removed in a few moments without tools. This facilitates servicing, or, if desired, double use of the Model 753 as both a mobile and fixed station. Fig. 2 provides all the required information for installing the mounting bracket and for attaching the transceiver to the bracket.

## MOBILE SPEAKER INSTALLATION

In mobile installations, it is usually most practical to use the automobile radio speaker. To do this, mount a DPDT switch underneath the dash, and use it to switch the speaker terminals to either the automobile radio or the speaker output of the Model 753. DO NOT use the automobile chassis as a ground return for the speaker, as an undesirable ground loop may be formed and result in an abnormal degree of "whine".

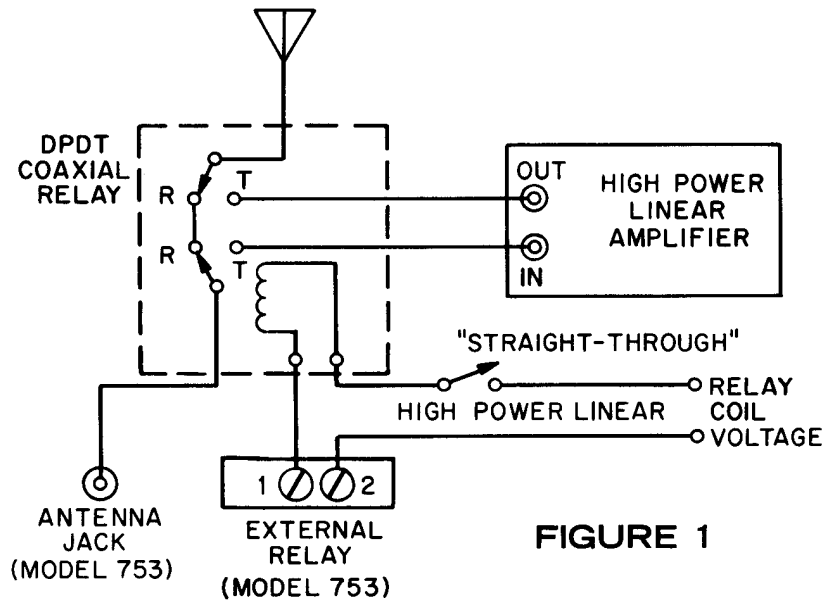
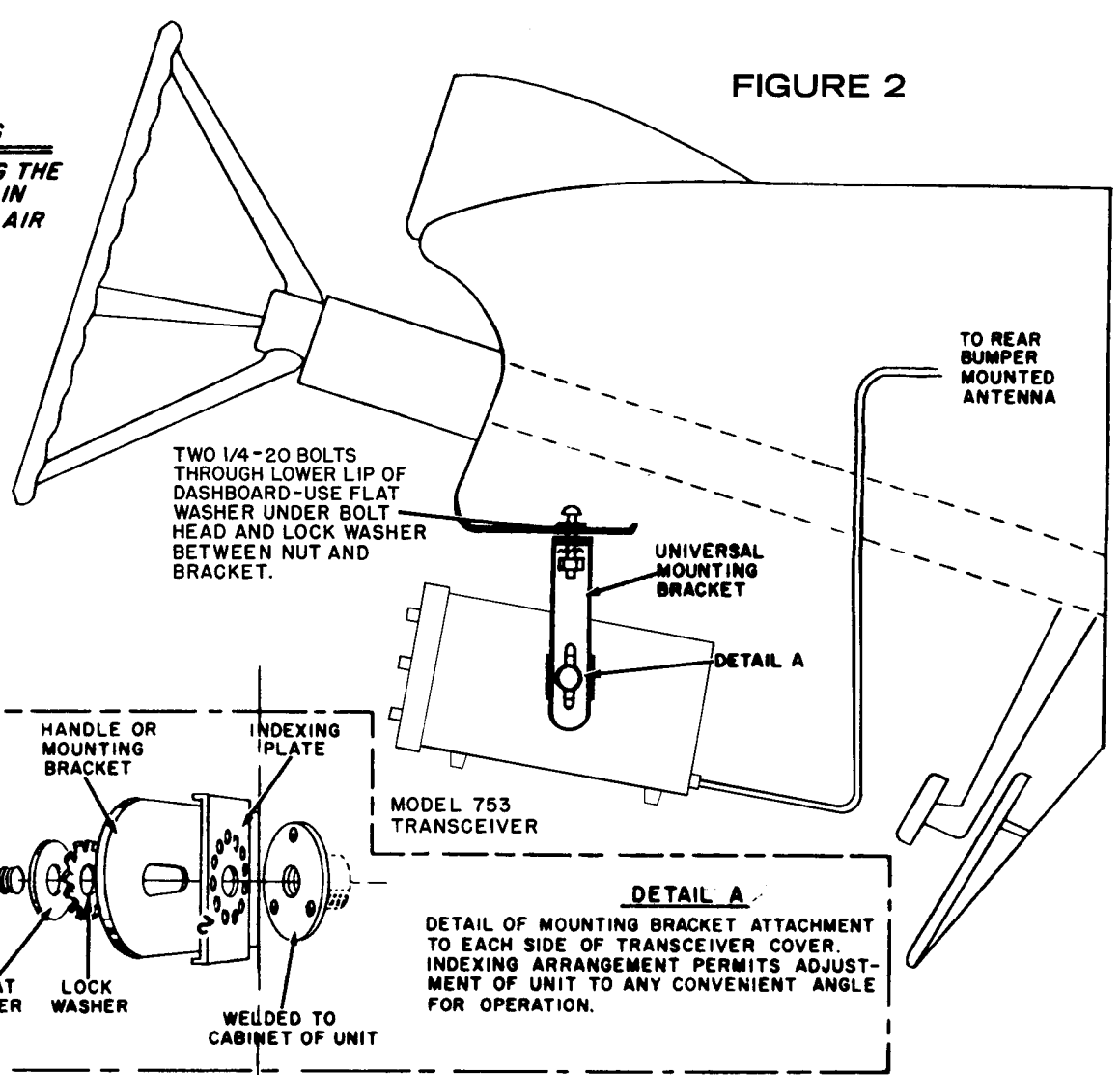
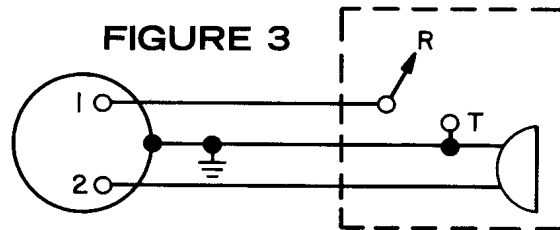

FIGURE 1



## MICROPHONE CONNECTIONS

An Amphenol Type MC2M plug, or the equivalent, must be used for connecting the microphone to the panel MIC receptacle. The microphone may be either a high impedance dynamic (preferred) or a ceramic type. Since all necessary audio bandwidth restriction is incorporated in the transceiver circuitry, a wide-range, high quality dynamic mike may be used and is most desirable. The required wiring to the MC2M plug is shown in Fig. 3.



### CAUTION

Interchanging of the microphone connections by incorrect wiring to the microphone plug will cause a negative bias voltage to be applied to the microphone cartridge, resulting in possibly serious damage.

## OPERATION

**IMPORTANT:** Before operation of the transceiver is attempted, a proper installation must be completed. This includes connection of a suitable antenna (40-80 ohms) to the ANTENNA jack, a correctly wired microphone to the MIC connector (or a key to the KEY jack at the rear), and a proper power cable from the power supply to the POWER plug. The FUNCTION switch must be set at OFF during the installation.

### SSB OPERATION

Preset panel controls as follows: (abbreviations: cw - clockwise, ccw - counterclockwise)

MODE switch.....at SSB  
MIC GAIN.....fully cw, but not past detent  
CARRIER BALANCE.....at 12 o'clock  
RF GAIN.....at 9 o'clock  
AF GAIN.....fully cw  
BAND selector.....at proper band  
MAIN TUNING.....at desired frequency  
RCVR OFFSET.....at centerline  
PA TUNE.....at 12 o'clock  
PA LOAD.....fully ccw  
EXCITER TUNE.....at 12 o'clock  
FUNCTION switch.....at STBY for 5 minute warmup, and then to P-T-T

### RECEIVER TUNE-UP FOR SSB OPERATION

1. Adjust PA TUNE and EXCITER TUNE for maximum audible signal strength or background noise. These adjustments result in approximate transmit tuning since they are common to receiver and transmitter.

2. Adjust AF GAIN for a normal listening level.

### TRANSMITTER TUNE-UP FOR SSB OPERATION

1. Set MODE switch at TUNE and adjust EXCITER TUNE for a maximum meter reading.

2. Adjust PA TUNE for a minimum meter reading (dip) to obtain correct tuning of the output PI network.



3a. If microphone is equipped with PTT switch, return MODE switch to SSB. Depress PTT button on mike and adjust the CARRIER BALANCE control for a minimum meter reading.

NOTE

If this is the first time the 753 is placed in operation, set the BIAS adjust on the rear apron so that the minimum meter reading obtained with the CARRIER BALANCE control in 3a above is 50mA.

3b. If the microphone is not equipped with a PTT switch, return the MODE switch to SSB. Set the FUNCTION switch at VOX. Leave the MIC GAIN fully ccw (but not past the detent).

NOTE

If this is the first time the 753 is placed in operation, now adjust the rear panel VOX controls as described in the NOTE of Step 2 in the subsequent MICROPHONE GAIN adjustment.

While holding the relay in the transmit condition with a steady tone or sound into the microphone, set the panel CARRIER BALANCE control as described in step 3a (and the rear apron BIAS adjust, as given in the NOTE following 3a, if this is the first time the 753 is placed in operation).

4. Reset the MODE switch at TUNE and adjust EXCITER tune and PA TUNE as described in steps 1 and 2. Slowly turn the PA LOAD control cw and "dip" meter reading with PA TUNE control until the meter reads between 250 and 300ma. Reset MODE switch to SSB. This completes proper tuning and loading of the transmitter.

5 NOTE  
*Seconds - important*

Tune-up procedures should not be prolonged more than ~~20~~ seconds in any one adjustment period to avoid excessive heating of components in out-of-resonance conditions.

ADJUSTMENT OF MICROPHONE GAIN

1. For push-to-talk operation, set FUNCTION switch at PTT. Depress mike PTT button and turn MIC GAIN control cw while speaking until the average meter reading is between 100 and 150ma. As the MIC GAIN is advanced further cw, a point will be reached where the average meter reading with uninterrupted speech will hover around 150ma. When this occurs, peaks will actually be in the 300ma region. If the MIC GAIN is advanced past this point, the average meter reading will not increase because of the ALC action. Do not turn the MIC GAIN clockwise past the point where there is no increase of the average meter reading on normal uninterrupted speech, as doing so will not increase output power but simply result in excessive gain and unnecessarily increased noise.

2. For VOX operation, turn the FUNCTION switch to VOX. Set the MIC GAIN control fully ccw (but not past the detent).

NOTE

If this is the first time the 753 is placed in operation, now adjust the rear apron VOX controls as follows (unless they have already been adjusted as required in the NOTE of step 3b, in the previous TRANSMITTER TUNE-UP FOR SSB OPERATION procedure).

Set the rear apron VOX controls as follows:

VOX-SENSITIVITY.....fully cw (max. sensitivity)  
VOX-THRESHOLD.....fully cw (guaranteed to return to receive)  
VOX-DELAY.....fully ccw (minimum delay)  
ANTI-VOX.....fully cw (maximum anti-vox)

Repetitively speak a few syllables into the microphone to trigger the VOX to "on" as often as necessary, while adjusting the VOX-DELAY control until the desired release time after speaking is obtained.

Now, turn the VOX-SENSITIVITY control ccw to a point where the relay trips easily while speaking into the microphone at normal level and distance, yet does not trip on normal background noise. In a mobile installation, this adjustment should be made for "close-talking", in order that the normal automobile and wind noises not cause the VOX to trigger.

Next, place the microphone in its normal position of use, and set the AF GAIN control for a normal listening level from the speaker as normally located. Then turn the ANTI-VOX control ccw (reducing ANTI-VOX gain) as far as it may go without permitting the VOX to be triggered to "on" by the sound from the speaker reaching the microphone. From this point, back off cw about 30 degrees of rotation to insure adequate anti-vox gain to handle voice peaks.

Now reset VOX-THRESHOLD to fully ccw position. Trigger the VOX to "on" by speaking one or two syllables into the microphone, and then turn the VOX-THRESHOLD control cw until the relay releases. As there may be some "chatter" at this critical point of the VOX-THRESHOLD control, turn it just slightly further cw than the critical point.

While holding the relay in the transmit condition by speaking steadily into the microphone, adjust the MIC GAIN control exactly as described in step 1 above. In a mobile installation, make this adjustment for "close-talking", in order that the normal automobile noises not cause the VOX to trigger.

3. The transceiver is now tuned and ready to operate. Re-adjust EXCITER TUNE and PA TUNE if the operating frequency is shifted substantially.

## MAIN TUNING CONTROL

The MAIN TUNING control has a unique dual ratio ball drive, permitting both 6:1 rapid tuning and 30:1 fine tuning. Fine tuning over 10 degrees of scale is obtained in the opposite direction of knob rotation used in rapid tuning. For this reason, turn slightly past the desired frequency in rapid tuning to assure that the exact desired tuning frequency will be in the range of the fine tuning.

## RECEIVER OFFSET TUNING

Permits fine tuning of the receiver  $\pm 10\text{kc}$  without disturbing the transmitting frequency or the initial calibration of the frequency dial. No offset from the transmitting frequency (and the frequency dial setting) is obtained with the RECEIVER OFFSET control set at the center line. Rotation cw from the center line lowers the receiving frequency, while ccw rotation from the center line raises the receiving frequency.

## CW OPERATION

1. It is assumed that the rear apron BIAS adjust has been set as described in TRANSMITTER TUNE-UP FOR SSB OPERATION. For break-in operation, it is also assumed that all VOX adjustments at the rear have been set as described in the note of step 2 of MICROPHONE GAIN ADJUSTMENT.

2. Insert key plug in KEY jack on rear apron.

3. Set BAND SELECTOR & MAIN TUNING to desired band and frequency.

4. Set MODE switch at TUNE and adjust transmitter as described in steps 1 and 2 of TRANSMITTER TUNE-UP FOR SSB OPERATION. The CARRIER BALANCE setting has no effect in CW operation.

5. For manual operation, set the MODE switch at CW and the FUNCTION switch at PTT. For the duration of a transmission with manual operation, either the microphone PTT button must be held depressed, or an external PTT switch wired to the microphone must be set at the transmit position. When the microphone PTT button is released, the receive condition is obtained.

6. For break-in operation, set the MODE switch at CW and the FUNCTION switch to VOX. Depressing the key automatically switches the VOX relay from receive to transmit, and the relay will hold at transmit until sending is stopped. The rear apron VOX-DELAY control may be readjusted to set the relay "hold-in" time as the operator desires.

#### NOTE

In CW operation, the usual practice is to transmit "zero beat" with the station being worked, which would seem to require the RCVR OFFSET tuning control be set at the center line (no offset). However, a small fixed offset, determined as follows, can be used to obtain a comfortable, consistent listening note in receive, while retaining exactly "zero beat" transmission. First, set the RCVR OFFSET tuning control at the center line (zero offset) and tune in a CW station to "zero beat" with the MAIN TUNING control. Since there is zero receiver offset, you will transmit "zero beat" with the station. Now turn the RCVR OFFSET tuning control in the direction of the strong side of "zero beat" to a point where a comfortable listening note is heard. This is the small, fixed offset referred to above, which should be retained throughout CW operation. Now, if you tune in any CW station subsequently with the MAIN TUNING control only (RCVR OFFSET remains as set previously), so as to produce the same comfortable listening note, your transmitter will then be tuned exactly "zero beat" with the received CW station.

#### AM OPERATION

1. The following procedure is based on the assumption that the 753 has been set up for SSB operation, and that it is now intended to operate AM.

2. Set the FUNCTION switch at either VOX or PTT, depending on the desired type of operation.

3. Set BAND selector and MAIN TUNING at desired band and frequency.

4. Set MODE switch at TUNE and adjust transmitter for a meter reading of 250-300ma under "tune" conditions.

5. Set MODE switch at AM, and turn MIC GAIN fully ccw (but not past detent). Now trip the relay to the transmit condition, either as described in step 1 (PTT operation) or step 2 (VOX operation) of MICROPHONE GAIN ADJUSTMENT.

6. If the CARRIER BALANCE has been adjusted previously as described for SSB operation, it is not necessary to readjust this control for AM operation. If the meter reading is below 150ma in transmit with the MIC GAIN fully ccw, a more critical adjustment of the EXCITER TUNE may be necessary. This adjustment may be made with the MODE switch at AM, and the EXCITER TUNE control adjusted for a peak meter reading (around 150ma).



7. Turn the MIC GAIN control cw until the meter is just on the verge of flickering on voice peaks, but no further. This will require a lower setting of the MIC GAIN control than is used in SSB operation.

8. The 753 is now properly set up for AM operation. Least distortion on AM reception will usually be obtained when tuned slightly to one side of "peak".

## ADDITIONAL NOTES ON CONTROLS

### MODE SWITCH

The rear apron KEY jack is internally disconnected at the SSB and AM positions of the MODE switch, thus allowing a key to be plugged into the KEY jack in all modes of operation. Note that in manual CW operation (FUNCTION switch at PTT), closing the key without depressing the PTT button (thus remaining at receive) may possibly result in an annoying audible oscillation. Of course, no transmission occurs. In break-in CW operation (FUNCTION switch at VOX), closing the key automatically causes the VOX relay to trigger to "on" and provides the desired break-in. In the TUNE position of the MODE switch, the keying circuit is internally grounded to place the transceiver in the transmit condition. Simultaneously, one of the 7360 balanced modulator deflection plates is grounded to provide greater than normal drive of the final amplifier for tune up. It must be noted that, with an antenna connected, full power CW transmission will occur at the TUNE position and cause undesired interference on the frequency in use. Therefore, perform the tune-up procedure as quickly as possible.

### PA TUNE & PA LOAD CONTROLS

Note that the PA TUNE and PA LOAD controls are inter-dependent. As the PA LOAD is turned cw (increasing the meter reading), repetitive readjustment of the PA TUNE control for a "dip" in the meter reading is required. At a meter reading of 250-300ma, proper loading to 200 watts peak input is obtained. Do not exceed a loading current of 300ma, as additional input power from a 750V supply will not provide increased output power because of decreasing efficiency of the 753 final amplifier.

In making these adjustments, it will be possible to observe whether the conditions for proper operation of the linear final amplifier are obtained; namely, proper idling current adjustment, and enough drive for adequate peak plate current in the off-resonance condition. Presuming proper setting of the rear apron BIAS control as given in OPERATION, and proper adjustment of the EXCITER tune control, a maximum off-resonance plate current greater than 350ma should be read on either side of the "dip" point obtained with the PA TUNE control. This value of off-resonance plate current may not be achieved if AC line voltage is below the rated input of 115 VAC with the Model 751 AC supply or below 12.0 VDC input with the Model 752 Mobile supply; also if, for any reason, there is low plate supply voltage to the final amplifier at full load, low driver B+ voltage, incorrectly operating exciter stages providing low drive, or defective final amplifier tubes. If low off-resonance plate current is obtained because of low AC line supply or battery voltage, operation will not be impaired as long as the PA LOAD control is not adjusted to produce excessive loading conditions. Do not, in any circumstance, advance the PA LOAD control so that the plate current at the resonant dip exceeds 85% of the off-resonance plate current observed by detuning the PA TUNE control.

If the "dip" point reading exceeds 300ma with the PA LOAD control turned fully ccw, then antenna load impedance is less than 40 ohms. If the "dip" point reading remains less than 300ma with the PA LOAD control turned fully cw, then antenna load impedance is over 80 ohms. If either of these conditions obtain, it will be necessary to adjust the antenna impedance to present a proper load at the transceiver antenna terminals. This may be done by means of impedance matching networks, or, in some cases, by adjusting the length of the transmission line to obtain a terminal impedance within the matching range. The remedy for a particular case (impedance below the matching range with a mobile antenna) is described under Antennas in the Installation section. Unless proper matching and loading is obtained, excessive distortion will occur in SSB operation.

## CARRIER BALANCE

Once the CARRIER BALANCE control is properly adjusted as described for SSB operation, it is to be left in this position for all subsequent SSB, AM, and CW work. Partial carrier unbalance is obtained automatically at the AM position of the MODE switch by connection of resistor R42 between one of the 7360 balanced modulator tube deflection plates and ground. This partial unbalance should be exactly that required to set up the transceiver for AM transmission, provided that the CARRIER BALANCE control is properly adjusted as described for SSB operation. In the CW position of the MODE switch, one deflection plate of the 7360 balanced modulator tube is automatically grounded to provide complete carrier unbalance. Thus, in CW operation, the CARRIER BALANCE control setting has no effect.

## CALIBRATION ACTIVATION

The 753 provides power and input connections for a 100kc crystal oscillator employing a tube with a 12.6 volt heater. A 4-pin plug (EBY #9721-71) must be wired to the calibrator connection cable as follows:

pin 1: 12.6 volt heater  
pin 2: Ground  
pin 3: Calibrator signal output  
pin 4: B+

The 4-pin plug may then be inserted in the CALIBRATOR socket on the rear apron. To activate the calibrator, the MIC GAIN control is turned fully ccw past the detent.

## AF GAIN CONTROL

May be used as a volume control in listening with either a loudspeaker or headphones. However, most operators prefer to run the AF GAIN wide open (fully cw) for SSB and CW reception, and use the RF GAIN control as a volume control.

## RF GAIN CONTROL

May be set in accordance with the operator's preferences, with, however, the understanding that the S-Meter reading is affected by the setting. Normal S-Meter operation is obtained with this control turned fully cw.

## S-METER ZERO ADJUSTMENT

Set the MODE switch at SSB and the RF GAIN fully ccw. Adjust the S-METER ZERO control on the rear apron for a zero S-Meter reading. The S-Meter will now read received signal strength or background noise.

All other control adjustments and uses are described fully in the Operation section.

## CIRCUIT DESCRIPTION

### TRANSMITTING

Two stages of microphone amplification are provided by V1A and V1B. A sample of the speech waveform is taken from the plate of V1A, before the MIC GAIN control, and applied to V3A, the VOX amplifier. A description of the VOX circuit is given in the Receiving section.

Balanced modulation is effected with the 7360 beam deflection tube, V2, which has as its grid input signal the output of the 5.2mc crystal-controlled carrier oscillator, V4A. Audio from V1B is applied between the deflection plates, and is R-C coupled through C7 and R9. The DC bias on the

dynamically grounded plate is adjusted with R20 to control the balance of the modulator. This balance is automatically upset in the AM mode by connection of R42 from one deflection plate to ground. Output is taken across the two anodes of the 7360, and coupled to the four pole crystal filter by means of T1.

Amplification at 5.2mc is provided by the common IF amplifier, V5, which follows the crystal filter output. The bias on the grid of this stage is modified by the ALC control voltage, which acts to decrease the stage gain when the peak input power to the final approaches the 200 watt level. Both the output of the common IF amplifier and the output of the VFO, Q1 and Q2, are applied to the transmitter mixer tube, V12, whose output circuit is tuned to the frequency in use. A dual section tuning capacitor, C93, tunes this stage and the following driver plate circuit.

Two VFO ranges are employed. The 8.7 to 9.2Mc range provides for both 80 and 20 meter operation, and the 12.2 to 12.5Mc range yields 40 meter operation. On 80 meters, the transmitter mixer selects the difference frequency between the 9Mc VFO and the 5.2Mc modulated signal from the common IF amplifier. These same two signals are added for 20 meter transmission. The mixer subtracts the 5.2Mc IF output from the 12Mc VFO signal on 40 meters.

CW grid-block keying is accomplished in the transmitter mixer stage. In the CW mode this stage is biased to cutoff with approximately 50 volts under key-up conditions. A relatively low plate voltage is employed on the mixer stage, the difference between this voltage and the +250 volt supply being taken up across R89. When the key is up and the stage is cut off, there is no current through R89, so that at these times the full 250 volts appears at the plates of V12. R90 and R95 form a voltage divider between the plate voltage of V12 and the -100 volt bias supply voltage. When the key is up and there is 250 volts at the plates of V12, the voltage at the junction between R90 and R95 is some small positive value. As soon as the key is depressed and V12 draws current, the voltage at this junction becomes negative. This change from positive to negative voltage when the key is depressed forms the trigger signal which provides CW break-in operation through the means of the VOX circuit.

After additional amplification by the driver stage V13, the signal is applied to the power amplifier, V14 and V15. The screen current in these tubes rises sharply as the control-grid voltage nears zero. Thus, since the screen is supplied through dropping resistor R111 from the +250 volt supply, the screen voltage drops when the grid voltage rises. This variation is detected by diode CR5, and then filtered before application to the control grid of the common IF amplifier. The gain of the common IF stage will vary depending on the output of this detector, and will be lowered when the final tends to operate near its non-linear region above zero grid voltage. Zero signal grid voltage for the final stage is set to approximately -55 volts by means of the BIAS adjust control, R108.

## RECEIVING

The same PI-network that matches the output of the transmitter to the antenna is used to couple the antenna to the receiver input amplifier, V16. Conversion of the amplified input to the IF frequency of 5.2Mc is accomplished in the receiver mixer, V11, which is fed by both the RF stage and the VFO. The plate circuit of V11 is tuned to 5.2Mc with the same transformer as is the balanced modulator. After passage through the crystal filter, three stages of IF amplification are provided by V5, V6, and V7. At the output of V7, a diode detector, CR3 and CR4, develops the AGC control voltage which is applied to the grids of V5, V6, V16 and V11, as well as to the S-Meter amplifier, V4B.

One section of V8 functions as a product detector in the CW and SSB modes. Signal from the third IF stage, V7, is applied to the grid of V8A while the output of the 5.2Mc crystal oscillator, V4A, is injected at the cathode. For AM reception, the cathode of V8A is grounded directly, causing this stage to function as a grid-leak detector. The 5.2Mc oscillator is disabled for AM reception. V8B provides audio frequency voltage amplification, and V9 yields the AF output to the speaker or headphones.

A RECEIVER OFFSET tuning control, R48, permits the receiving frequency to be offset from the transmit frequency by up to  $\pm 10$ kc. It operates by controlling the bias on a voltage variable capacitor (varicap), CR6, across the VFO tuning capacitor in the receive condition. In the transmit condition,

the bias on CR6 is taken from a fixed center-tap on R48, so that the frequency is independent of the setting of the RECEIVER OFFSET tuning control. The receiver and transmitter will operate on the same frequency when the control is set at mid-rotation (center line on panel).

## VOX CIRCUIT

A six pole relay controls the voltage and biases to the various stages of the transceiver, and determines whether the unit is in the receive or transmit condition. Triode V3B has, as its plate load, the coil of the relay. When V3B is cutoff, the relay is unenergized and the condition is "receive". Cutoff is maintained by a negative bias which is applied through R26 to the grid of V3B.

When an audio signal is applied to the VOX amplifier V3A, from the first microphone amplifier V1A, V3A tends to draw less plate current. This causes the plate voltage at V3A to rise, thus firing the neon bulb PL3 and causing the voltage of the grid of V3B to rise. This brings V3B into conduction, and the relay closes. The transceiver is now in the transmit condition. After the voice peak has passed, PL3 extinguishes and there is no longer any electrical connection between V3B and any other part of the VOX circuit. The grid voltage of V3B now tends to return to its original negative value, and does so with a time constant which depends upon R26, C19, and the setting of the VOX-DELAY control, R32. With the arm of R32 set to the plate end of the control, C19 will have a "virtual" capacitance of approximately its own value times the gain of the stage V3B. As the arm of the control is moved away from the plate end, the effective capacitance in the grid circuit is reduced; when it is at the ground side of the control, the circuit capacitance is merely the value of C19. This change of effective grid circuit capacitance with stage gain is known as "Miller effect".

When the voltage at the grid of V3B decays to a sufficiently high negative value, the relay returns to the "off" condition and the unit is in "receive" again. The voltage at the grid of V3A is adjusted so that PL3 is just on the verge of firing when there is no speech input. This assures that the sensitivity of the VOX circuit is always at a maximum. This bias is adjusted with R24, the VOX-THRESHOLD control. If a speaker is being used there is the possibility that the microphone will pick up the audio from the speaker and cause the VOX to trip. The anti-vox detector, CR1 and CR2, desensitizes the VOX amplifier by converting a sample of the receiver output signal into a positive bias which brings V3A into a heavier state of conduction. The amount of anti-vox injection is controlled with the ANTI-VOX sensitivity control, ~~R72~~  
R27

In order to prevent transient voltages, which occur during relay switching, from accidentally triggering the VOX circuit, the relay control tube is cut off for a short period of time immediately after the unit switches to receive. A high negative pulse is fed through PL4 to the grid of V3B, and its duration is such that it keeps V3B cut off (and, thereby, the unit in the receive condition) until the switching transients have decayed.

## MAINTENANCE

### GENERAL

Your transceiver should require little service except for normal tube replacement. Do not substitute for tube types used in this transceiver. Factory-wired transceivers have been completely aligned and adjusted at the factory before shipment. Transceivers built from the kit must be aligned as described in the Alignment Procedure given. (Note that the crystal filter supplied in the kit has been pre-adjusted and aligned at the factory).

### CABINET REMOVAL

To remove the instrument from the cabinet, first disconnect it from its power supply, and then remove four #6 sheet metal screws at the rear and seven #6 sheet metal screws on the bottom. Unit can be removed from the front of the cabinet.

## ALIGNMENT PROCEDURE

Before proceeding with the alignment, the transceiver should be removed from the cabinet and the cover should be removed from the VFO compartment. In removing the latter, it will be necessary to temporarily remove the fibre extension shaft from the P. A. tuning capacitor. The shaft should be reinserted after the VFO cover is removed.

A 40 to 80 ohm dummy load capable of dissipating at least 125 watts should be available. A 100 watt light bulb may be substituted for the dummy load if necessary. Some means of measuring relative R. F. power output to the dummy antenna should also be provided. An R. F. ammeter or an in-line watt meter will be helpful toward this end.

Three reference signals from a well calibrated VFO or crystal oscillator will be necessary. These are 7.00Mc, 7.30Mc, and 3.80Mc. VFO alignment should not be attempted unless the signal source is well calibrated. If a calibrated communications receiver is available, it may be used to set the external source. In any case, a crystal oscillator is to be preferred.

## RECEIVER ALIGNMENT

### a) IF Strip

1. The transceiver should be connected to the EICO 751 (or 752) power supply. There should be no microphone connected to the unit at this time. Before turning the unit on, set the controls as follows:

MIC GAIN.....fully ccw (but not past detent)  
RF GAIN.....fully ccw  
AF GAIN.....fully ccw  
CARRIER BALANCE.....mid-rotation  
MODE SWITCH.....SSB  
FUNCTION SWITCH.....OFF  
MAIN TUNING FREQUENCY.....7.00Mc  
PA TUNE.....Mid-rotation  
BAND SWITCH.....40 meters  
PA LOAD.....fully ccw  
RCVR OFFSET.....mid-rotation (at centerline)  
EXCITER TUNE.....mid-rotation  
NEUTRALIZING CAPACITOR C107.....fully un-meshed

2. Connect a small capacitor (between 20 and 50pf) from pin 3 of V4 to pin 7 of V17. This is a temporary measure and is best done with a pair of clip leads.

3. Set the FUNCTION switch at STANDBY, and after one or two minutes of warmup, reset it at PTT.

4. Advance the RF GAIN control to the fully cw position, and adjust the slugs of IF coils T3, T4, and T5 for maximum S-Meter reading.

5. Return the RF gain control to its fully ccw position, and turn the FUNCTION switch to OFF. Disconnect the clip leads installed in step (2).

This completes the IF strip alignment.

### b) VFO

1. The controls are set as in step 1 of part (a).

2. Set both trimmer capacitors C40 and C42, on the VFO board, to mid-rotation.

3. Apply an unmodulated 7.00Mc signal to the ANTENNA connector on the rear apron. This signal should be quite weak (approximately 100uV), which may require very loose coupling between the signal generator or oscillator to the transceiver.

4. Set the FUNCTION switch at STANDBY, and after one or two minutes of warmup, turn it to PTT.

5. Turn the RF GAIN control to the fully cw position, and then turn up the AF GAIN control until normal receiver noise is heard.

6. With the MAIN TUNING control set to 7.00Mc, adjust the slug of VFO coil L4 until zero beat is heard in the loudspeaker. The S-Meter reading may be peaked with the EXCITER TUNE control and with the PA TUNE control. If it is not possible to peak the signal with the EXCITER TUNE control, set this control to mid-rotation and adjust the slug of coil L11 to peak the meter reading. The RF GAIN control should be adjusted to yield an S-9 reading.

7. Apply a 7.30Mc input signal to the ANTENNA terminal, as per the procedure in step (3).

8. Turn the MAIN TUNING control toward the high end of the 40 meter band until the applied signal is heard. If it is heard at an indicated frequency that is higher than 7.30Mc, unmesh the plates of C40 by several degrees of rotation, and repeat steps (3) through (8). It will not be necessary to make further adjustments on L11 at this time.

If the signal is heard at an indicated frequency of less than 7.30Mc, mesh the plates of C40 by several degrees of rotation and proceed as above. This procedure is continued until the signal is heard at exactly 7.30Mc on the dial. Do not proceed to step (9) until this condition is achieved.

9. Set the FUNCTION switch at STANDBY, and the BAND switch at 80 meters.

10. Set the MAIN TUNING control at 3.80Mc, and leave the RF GAIN and AF GAIN controls in the positions they had upon the completion of step (6).

11. Apply an unmodulated signal of 3.80 Mc to the ANTENNA connector.

12. Set the FUNCTION switch at PTT, and adjust trimmer capacitor C42 until zero-beat is heard. The signal should be peaked on the S-Meter by setting the EXCITER TUNE control to mid-rotation and adjusting the slug of L10.

13. Replace the VFO cover and secure it with four #6 self-tapping screws. This completes the VFO alignment. There should be a negligible change in dial readings due to the presence of the VFO cover. If it is desired to correct for this change, the hairline may be reset from the front panel.

### c) TRANSMITTER ALIGNMENT

1. The controls should be set as in step (1) of part (a) of the preceding RECEIVER ALIGNMENT, except for the following:

BAND SWITCH..... 20 meters  
MODE SWITCH..... CW  
MAIN TUNING FREQUENCY..... 14.15Mc  
NEUTRALIZING CAPACITOR C107..... to about 20% of full mesh

2. Connect a suitable dummy antenna to the ANTENNA connector, and an output power meter (RF ammeter, etc.) to the connecting transmission line. Connect a microphone with a PTT button (or an external PTT switch) to the MIC connector. Do not connect key.



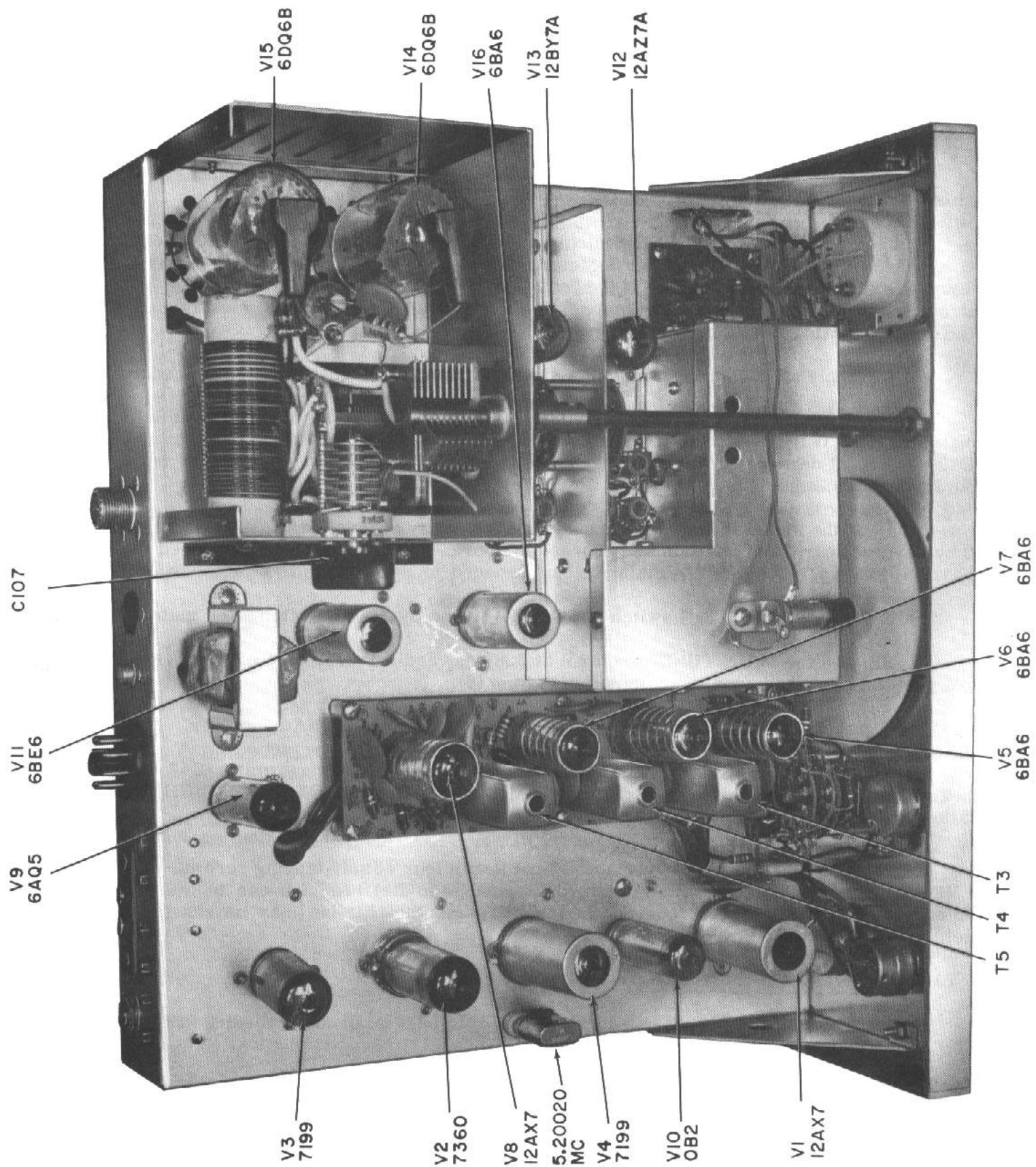

FIGURE 4

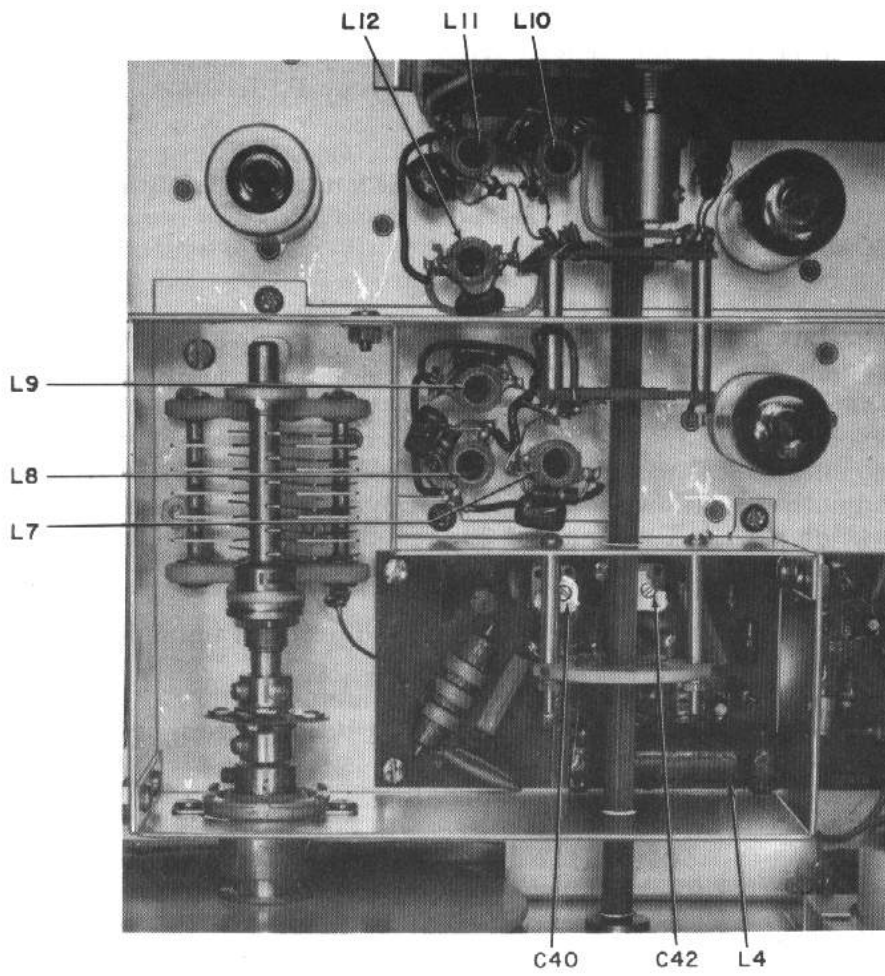
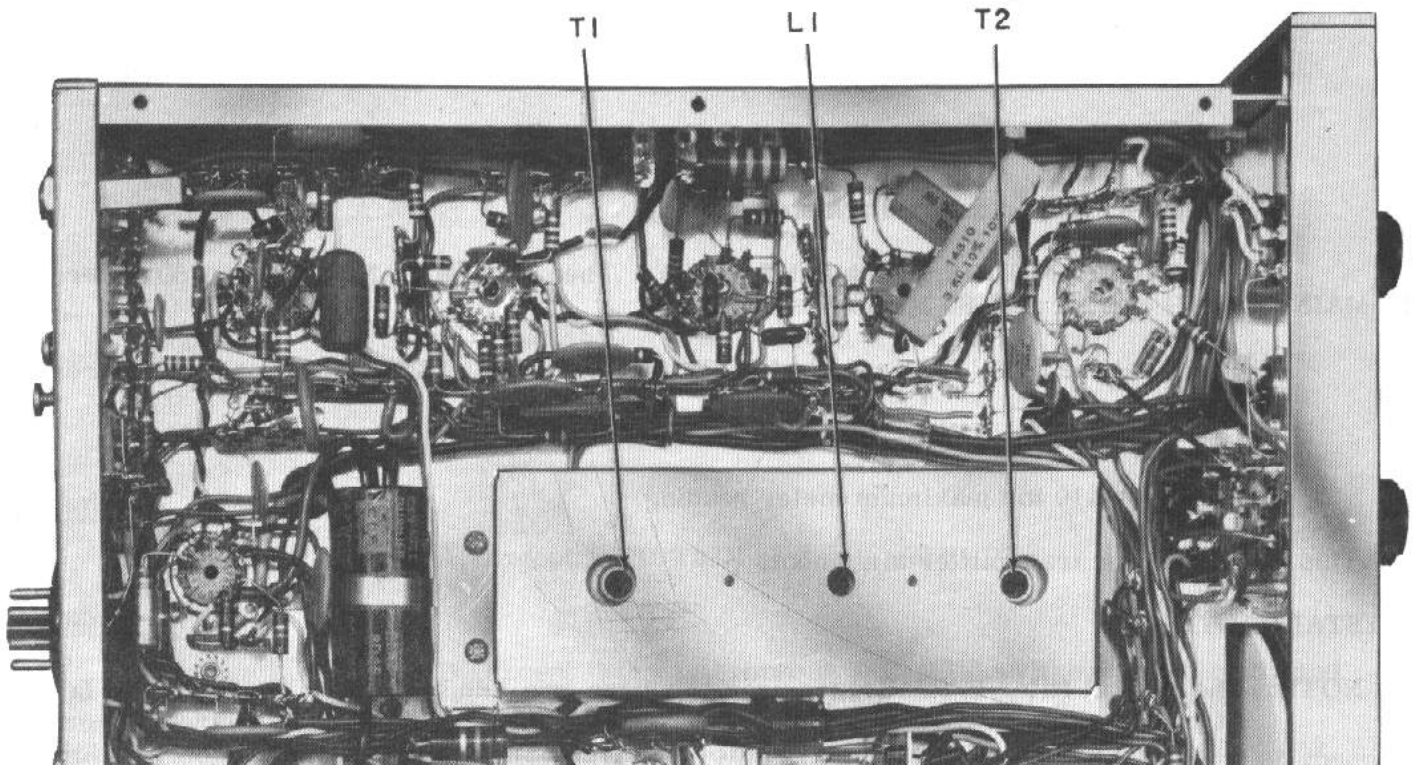

FIGURE 5



3. Set the FUNCTION switch at STANDBY, and, after one or two minutes of warm-up, reset the FUNCTION switch at PTT. Depress the microphone PTT button, and adjust the rear apron BIAS control for a meter reading of 50mA.

4. Release the microphone PTT button. It will not be used again in this procedure

5. Set the MODE switch at TUNE.

#### CAUTION

Do not allow the unit to remain in the "tune" condition for more than about 20 seconds at a time, to avoid excessive heating of components in out-of-resonance conditions. If more time is required to make an adjustment, allow the final to cool by setting the MODE switch back at CW for about 30 seconds before continuing.

6. Adjust L9 for a maximum meter reading, and proceed immediately to step (7).

7. Adjust the PA TUNE control for a minimum meter reading. The plate current should fall below 200ma, since the PA LOAD control is already at its maximum ccw position.

8. Adjust coil L12 for a peak meter reading.

9. The neutralizing capacitor, C107 must be adjusted so that maximum output power is obtained at minimum plate current (dip). Slowly rotate the PA TUNE control and simultaneously note the relative output power and the plate current. If maximum output does not occur at plate current dip, make a slight readjustment of the neutralizing capacitor and repeat the above test. After proper neutralization is achieved, repeat steps (6), (7), and (8) above.

10. Set FUNCTION switch at STANDBY, and then set the BAND switch at 40 meters, and the MAIN TUNING control at 7.15Mc.

11. Re-set the FUNCTION switch at PTT, and adjust L8 for a maximum meter reading.

12. Adjust the PA TUNE control for plate current dip.

13. Adjust L11 for maximum meter reading.

14. Set the FUNCTION switch at STANDBY. Then set the BAND switch at 80 meters, and the MAIN TUNING control at 3.80 Mc.

15. Re-set the FUNCTION switch at PTT, and then adjust L7 for a maximum meter reading.

16. Adjust the PA TUNE control for a plate current dip.

17. Adjust L10 for maximum meter reading.

This completes the transmitter alignment.

#### CRYSTAL FILTER

NOTE: The crystal filter in this transceiver has been pre-adjusted and aligned at the factory. At most, only one slight adjustment will be necessary, if at all. The following procedure should be employed only if the sound of received SSB signals appears to be unnatural or distorted.

1. Set the transceiver up in the receive condition and apply an input signal to the ANTENNA connector. The signal may be on any frequency in any of the three bands covered. Tune the transceiver to this signal and set the RF GAIN control so that, at maximum, the S-Meter reads S-9.

2. Upon tuning slowly past the signal, the S-Meter should indicate two peaks, both on the same side of zero-beat. If the RF gain control has been set so that, at each peak, the reading is S-9, then at zero beat the meter should read between S3 and S4. If this is not the case, or if both peaks do not yield equal S-readings, proceed to step (3). Otherwise, the filter is in proper alignment and no adjustments should be made.

3. Tune the receiver to a point midway between the two peaks, and adjust the slug of T2 for maximum S-Meter reading. Repeat step (2) above. If the filter is still not in alignment, offset the slug of T2 slightly, and repeat the measurement. The setting of this coil will be quite critical and its adjustment must be made carefully. If it is not possible to achieve a reasonable pass-band by adjusting T2, set T2 for a maximum S-Meter reading midway between the two peaks and proceed to step (4).

4. Repeat the procedure in step (3), only this time adjust the slug of transformer T1 on the crystal filter assembly. Exercise caution in making this adjustment since too great a misalignment of this coil will cause the pass-band to widen, thereby reducing selectivity and sideband suppression. It will be possible to properly align the filter by repeating steps (3) and (4) several times until the desired pass-band is obtained. No adjustment of L1 will be necessary.

#### DC VOLTAGE AND RESISTANCE CHART

The following chart lists the approximate DC voltages and resistances to ground at each of the terminals of those tube sockets which are chassis mounted, and is offered as an aid in troubleshooting. Reasonable deviations from the values given should be expected and cause no concern, since component values will vary within their allowable tolerances to produce such deviations.

Three tables are listed. The first, Column A, lists the DC resistance to ground from each tube socket pin. These values are to be measured with no external connections to the transceiver, meaning that the power supply, speaker, antenna, microphone, etc., are all disconnected. For the DC voltages, Columns B and C, only the power supply is connected to the unit. The readings given are those to be expected when using the EICO Model 751 AC power supply under normal (117V) line voltage conditions. In all cases, the front panel controls are to be set as indicated below:

##### Column A:

FUNCTION SWITCH.....OFF  
MODE SWITCH.....SSB  
CARRIER BALANCE.....mid-rotation  
PA TUNE.....mid-rotation  
EXCITER TUNE.....mid-rotation  
RCVR OFFSET.....mid-rotation  
MIC GAIN.....fully ccw (but not past detent)  
RF GAIN.....fully ccw  
AF GAIN.....fully ccw  
PA LOAD.....fully ccw

##### Column B:

Same as for Column A, except FUNCTION switch is set at PTT

##### Column C:

Same as for Column B, except that a microphone with PTT switch is connected, and the PTT button is depressed; also, the MODE switch is set at CW.

Voltage checks are made with a vacuum-tube voltmeter having an input impedance at the probe of 11 megohms. The heater voltages on the various tubes are listed as AC, since the 751 AC power supply is being used to power the unit for measurement purposes.

## VOLTAGE AND RESISTANCE CHART

TUBE	PIN	A RESISTANCE TO CHASSIS	B DC VOLTAGE WITH RESPECT TO CHASSIS	C DC VOLTAGE WITH RESPECT TO CHASSIS
V1	1	475K	90V	90V
	2	100K	0	0
	3	2.2K	1V	0
	4	0	12.6 AC	12.6 AC
	5	0	12.6 AC	12.6 AC
	6	100K	265 V	265 V
	7	75K	-42V	-100 V
	8	1K	0	0
	9	0	6.3 AC	6.3 AC
V2	1	1.8K	0	0
	2	80K	265V	225 V
	3	600K	-42 V	0
	4	0	12.6 AC	12.6 AC
	5	0	6.3 AC	6.3 AC
	6	50K	265 V	200 V
	7	50K	265 V	200 V
	8	55K	35 V	25 V
	9	55K	35 V	0
V3	1	22K	265 V	75 V
	2	500K	8 V	8 V
	3	1 Meg	13 V	13 V
	4	0	6.3 AC	6.3 AC
	5	0	12.6 AC	12.6 AC
	6	100Ω	0	0
	7	00	0	0
	8	0	0	0
	9	20 Meg	Do not measure	0
V4	1	28K	265 V	0
	2	20K	250 V	220 V
	3	15K	40 V	200 V
	4	0	12.6 AC	12.6 AC
	5	0	6.3 AC	6.3 AC
	6	0	0	0
	7	470K	-1.7 V	0
	8	1.4K	13 V	0
	9	600K*	0	-100 V
V9	1	1.5 Meg	0	-90 V
	2	270Ω	11 V	0
	3	0	12.6 AC	12.6 AC
	4	0	6.3 AC	6.3 AC
	5	9.5K	250 V	270 V
	6	20K	240 V	270 V
	7	1.5 Meg	0	-90 V
V10	1	6.5K	110 V	110 V
	2	0	0	0
	3	00	—	—
	4	0	0	0
	5	6.5K	110 V	110 V
	6	00	—	—
	7	0	0	0

TUBE	PIN	A	B	C
V11	1	620K	-2 V	-95 V
	2	0	0	0
	3	0	12.6 AC	12.6 AC
	4	0	6.3 AC	6.3 AC
	5	12K	275 V	275 V
	6	55K	75 V	0
	7	1 Meg*	0	-90 V
V12	1	25K	260 V	265 V
	2	55K	-50 V	-50 V
	3	560Ω	0	0
	4	0	0	0
	5	0	0	0
	6	25K	260 V	265 V
	7	55K	-50 V	-50V
	8	560Ω	0	0
	9	0	6.3 AC	6.3 AC
V13	1	0	0	0
	2	130K	-50 V	-4 V
	3	0	0	0
	4	0	0	0
	5	0	12.6 AC	12.6 AC
	6	0	6.3 AC	6.3 AC
	7	10K	275 V	210 V
	8	2.2K	0	240 V
	9	0	0	0
V14	1	00	0	0
	2	0	6.3 AC	6.3 AC
	3	00	0	0
	4	470Ω	0	270 V
	5	85K	-90 V	-60 V
	6	00	0	0
	7	0	0	0
	8	7.5Ω	0	.37 V
V15	1	00	0	0
	2	0	6.3 AC	6.3 AC
	3	00	0	0
	4	470Ω	0	270 V
	5	85K	-90 V	-60 V
	6	00	0	0
	7	0	12.6 AC	12.6 AC
	8	7.5Ω	0	.37 V
V16	1	1.8 Meg	0	-90 V
	2	0	0	0
	3	0	0	0
	4	0	6.3 AC	6.3 AC
	5	10K	280 V	210 V
	6	80K	220 V	0
	7	10K	23 V	0

\*These resistance measurements are made with the + voltmeter lead on the tube pin and the -lead on chassis. The resistance depends upon one or more diodes in the circuit and will change if the meter leads are reversed.



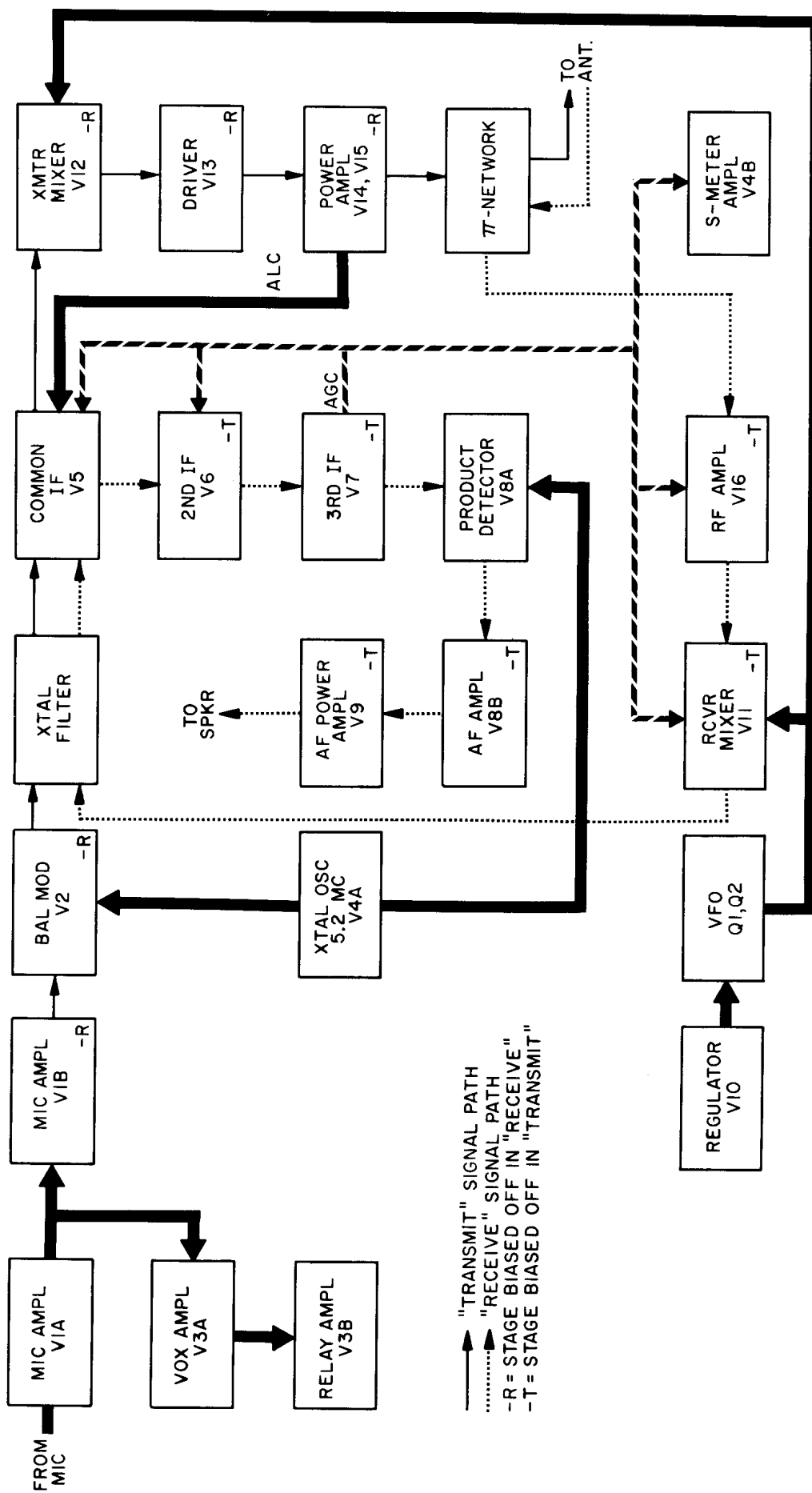

FIGURE 7

PRICE EACH	SYM. #	STOCK#	DESCRIPTION
<u>CAPACITORS</u>			
(In UF, unless otherwise specified)			
.13	C1, 50, 94	22007	tubular, cer., 47pf, 500V, 20%
.50	C2	23042	elec., 2/15V
.33	C3, 4	22544	disc, .02pf, 500V, 10%
.45	C5, 9, 10, 15, 20, 25, 47, 54, 74, 104, 120	22560	disc, .05, 500V, GMV
.15	C6	22532	disc, .0015, 500V, 10%
.14	C7, 23, 32, 99, 119, 126	22535 8	disc, <del>.001, 1KV, 10%</del> .01 50V GMV
.22	C8, 13, 19, 21, 31, 35, 44, 45, 57, 58, 59, 61, 65, 66, 69, 70, 80, 85, 87, 89, 98, 111, 112	22513	disc, .005, 500V, 10%
.13	C11, 14, 18, 29, 30, 46, 49, 51, 52, 53, 71, 73, 84, 95, 118	22505	disc, .01, 500V, GMV
.36	C12, 27, 72	20092	mylar, .1, 250V
.60	C16, 86	20057	mylar, .47, 200V
.14	C17, 77, 79, 83	22539	disc, 200pf, 500V, 10%
.25	C22, 91, 101, 122	21252	molded s. m., 90pf, 300V, 5%
.25	C24, 55, 56, 60, 62, 97, 106, 121	21253	molded s. m., 100pf, 300V, 5%
1.60	C26	23000	elec., 2 x 8/450V
.82	C28	23073	elec., 2/160V
.71	C34	21515	molded s. m., .001, 500V, 1%
.86	C33	22027	tubular, cer., 100pf, N750, 500V, 1%
.86	C36	22028	tubular, cer., 25pf, N750, 500V, 1%
.75	C37	21517	molded s. m., 145pf, 500V, 1%
.15	C38	22606	disc, 18pf, 500V, 5%
.15	C39	22571	disc, 5pf, 500V, 5%
3.06	C40, 42	29522	var. trimmer, 2-14pf
.42	C41, 48	22017	tubular, cer., 10pf, 500V, ± 25pf
4.90	C43	29019	var., air, 8-32pf
.13	C63, 64, 75	22010	tubular, cer., 7pf, 500V, 20%
.29	C67	21255	molded s. m., 150pf, 300V, 5%

PRICE EACH	SYM. #	STOCK#	DESCRIPTION
.43	C68	21254	molded s. m., 300pf, 300V, 5%
.23	C76, 90, 100	21256	molded s. m., 62pf, 300V, 5%
.15	C78, 81, 82	22597	disc, .002, 500V, 10%
.65	C88	23001	elec., 10/25V
.23	C92, 96, 102	21257	molded, s. m., 22pf, 300V, 5%
12.00	C93	29025	var., 2 x 50pf
.30	C103	21007	mica, 470pf, 500V, 5%
.36	C105, 124, 125	21258	mica, 220pf, 500V, 5%
3.12	C107	29521	var., trimmer, 5-20pf
.26	C108	22583	disc, .01, 2KV, GMV
.26	C109	22602	disc, .001, 3KV, 10%
.23	C110	22519	disc, .01, 500V, 10%
.19	C113	22558	disc, .50pf, 3KV, 10%
5.67	C114	29011	var., air, 140pf
.23	C115	22600	disc, 27pf, 500V, 10%
.24	C116	21019	mica, 330pf, 500V, 10%
3.75	C117	29018	var., air, 2 x 420pf
.23	C123	22625	disc, 100pf, 3KV, 10%

#### DIODES

1.08	CR1, 2, 3, 4, 5	95002	IN295
2.28	CR6	96400	varicap, IN3182
3.60	CR7	93031	Zener, 20V

#### JACKS & SCREW TERMINAL BOARDS

1.80	J1	50036	microphone connector
.65	J2	50003	jack, phone, open circuit
.14	J3	54513	term. board, 2 screw
1.74	J4	50023	receptacle, VHF
.60	J5	51007	plug, octal, chassis mtg.
.10	J6	50014	jack, phono
.67	J7	50022	jack, phone, closed circuit
.22	J8	50026	socket, 4-pin min.

#### COILS

1.41	L1	36056	filter
.87	L2	35052	RFC, 100uh
2.70	L3	35076	RFC, 1mh, 300ma, cer.
2.58	L4	36055	slug, tuned, cer., 8.7uh
.81	L5, 14, 15	35034	RFC, 1mh, 125ma
2.10	L6	35075	RFC, 2.5mh, 50ma
.90	L7, 10	36052	slug-tuned, 12uh
.90	L8, 11	36054	slug-tuned, 3.5uh
.90	L9, 12	36053	slug-tuned, 1.5uh
4.95	L13	35077	pi-coil, multi-tap, cer.

## PARTS LIST

PRICE EACH	SYM. #	STOCK#	DESCRIPTION
<u>METER</u>			
12.50		75006	meter, 1ma (includes lamp PL2)
<u>P. C. BOARDS</u>			
3.83		82520-1	VFO
6.36		82521	IF strip
3.67		82522	crystal filter
<u>LAMPS</u>			
.21	PL1	92000	pilot lamp, #47
.41	PL3,4	92005	neon lamp, NE-2
<u>PARASITIC TRAP</u>			
.72	PT1,2	35037	parasitic trap
<u>RESISTORS &amp; POTENTIOMETERS</u>			
(All resistors are 1/2 watt, 10%, unless otherwise stated)			
.08	R1, 13, 78	10430	4.7KΩ
.08	R2, 8, 19, 52, 79, 84, 96, 97, 105	10410	100KΩ
.08	R3, 34, 63, 64, 70, 104	10423	2.2KΩ
.08	R4, 25, 27, 33, 36, 82	10431	470KΩ
3.19	R5	18154	pot, 1MΩ, w/switch
.09	R6, 9, 14, 53, 58, 69, 73, 77, 118, 119, 123	10428	47KΩ
.08	R7, 72, 124, 128	10432	1KΩ
.09	R10, 11, 12, 44, 126	10422	68KΩ
.08	R15	10414	1.8KΩ
.08	R16	10440	12KΩ
.08	R17, 18	10413	2.7KΩ
1.87	R20	18150	pot, 5KΩ
4.84	R21, 22, 24, 32	18155	4 pot board
.08	R23, 41, 60	10417	220KΩ
.09	R26	10405	20MΩ
.08	R28, 30, 31, 43, 61, 80, 86, 117	10407	1MΩ
.11	R29, 59, 67	10439	100Ω
.08	R35, 40, 88, 91, 92, 120, 121	10400	10KΩ

PRICE EACH	SYM. #	STOCK#	DESCRIPTION
.14	R37, 116	11540	1.5KΩ
.75	R38	10601	33KΩ, 2W, 5%
3.61	R39, 108	18156	2 pot board
.08	R42	10455	1.5MΩ
.08	R45, 50, 107	10416	15KΩ
.36	R46	14310	3KΩ, 10W, 10%
.35	R47	14503	2.5K, 5W, 10%
2.29	R48	18151	pot, 2KΩ
.14	R49	11513	3KΩ, 1/2W, 5%
.11	R51, 56, 68, 71, 74, 94, 98, 109, 110, 125	10451	27KΩ
1.97	R54	18153	pot, 10KΩ
.10	R55, 62	10436	47Ω
.27	R57	10958	22KΩ, 2W, 10%
.08	R65	10426	33KΩ
.08	R66	10453	18KΩ
.11	R75	10446	270Ω
.08	R76, 83, 103	10434	2.2MΩ
.08	R81, 122	10406	680Ω
2.00	R85	18152	pot, 1MΩ
.07	R87	10884	270Ω, 1W, 10%
.16	R89	10852	15KΩ, 1W, 10%
.29	R90	11548	1MΩ, 1/2W, 5%
.11	R93, 100, 101	10424	22KΩ
.29	R95	11531	470KΩ, 1/2W, 5%
.08	R99	10429	470Ω
.34	R102	10964	1KΩ, 2W, 10%
.18	R106	10857	2.2KΩ, 1W, 10%
.18	R111	10861	470Ω, 1W, 10%
.11	R112, 113	10461	22Ω
.46	R114, 115	10761	15Ω, 1W, 5%
.11	R127	10463	220Ω
.11	R129	10424	22K
<u>RELAY</u>			
24.60	RY	39006	relay, 6 pole, double throw
<u>SWITCHES</u>			
5.92	S1	60164	switch, rotary, 4 pos., 1 deck
7.20	S2	60163	switch, rotary, 4 pos., 2 deck
4.56	S3, A, B, C	60165	switch kit (includes: 89760-1-2, 41150, 40022, 42067-8, 44022-3)
6.96	S3D	60166	switch, rotary, 3 pos., cer.

PRICE EACH	SYM. #	STOCK#	DESCRIPTION
<u>TRANSFORMERS</u>			
2.82	T1	34649	interstage
2.58	T2	34650	filter coil (output)
1.44	T3, 4, 5	34651	IF coil
2.08	T6	32044	AF output

TERMINAL BOARDS

.10	TB1	54002	1 post right with ground
.10	TB2, 5, 11, 20, 29, 31	54018	4 post with ground
.10	TB3, 6, 7, 8, 13, 21, 23	54004	2 post with ground
.10	TB4, 9, 18	54008	4 post
.10	TB10	54019	2 post right
.10	TB12, 17, 22	54015	3 post, 2 left, with ground
.10	TB14, 26, 32	54003	2 post
.10	TB15	54013	1 post left, with ground
.10	TB16	54001	1 post right
.10	TB19, 24, 27	54007	3 post, 2 right, with ground
.10	TB25	54014	3 post, 2 left
.10	TB28	54005	2 post right with ground
.10	TB30	54006	3 post, 2 right

TUBES AND TRANSISTORS

1.80	Q1, 2	94044	2N2926
2.52	V1, 8	90034	12AX7
9.00	V2	90102	7360
3.36	V3, 4	90090	7199
2.00	V5, 6, 7, 16	90062	6BA6
2.12	V9	90047	6AQ5
3.08	V10	90070	OB2
2.28	V11	90063	6BE6
2.60	V12	90098	12AZ7A
3.08	V13	90064	12BY7A
4.28	V14, 15	90067	6DQ6B

CRYSTALS

3.95	X1, 2	49114	filter, 5.2015mc
3.95	X3, 4	49115	filter, 5.2030mc
3.95	X5	49113	oscillator, 5.2002mc

CRYSTAL SOCKET

.23	XS1, 2, 3, 4, 5	97501	ceramic crystal socket
-----	-----------------	-------	------------------------

TUBE SOCKETS

.27	XV1, 2, 4	97027	9 pin socket (shield)
.24	XV3, 12, 13	97039	9 pin socket

PRICE EACH	SYM. #	STOCK#	DESCRIPTION
.20	XV5, 6, 7	97055	7 pin socket (printed circuit)
.25	XV8	97056	9 pin socket (printed circuit)
.17	XV9, 10	97022	7 pin socket
.28	XV14, 15	97041	octal socket
.23	XV16, 11	97047	7 pin socket (shield)

MISCELLANEOUS COMPONENTS & HARDWARE

.01	40000	nut, 6-32, hex	(41)
.02	40001	nut, 3/8-32", hex	(18)
.02	40004	nut, 2-56, hex	(4)
.01	40007	nut, 4-40, hex	(45)
.01	40008	nut, 8-32, hex	(4)
.01	41000	screw, 6-32 x 1/4" B.H.	(4)
.01	41003	screw, 8-32 x 3/8	(1)
.01	41007	screw, 6-32 x 3/4	(2)
.01	41010	screw, 6-32 x 1/8	(1)
.01	41032	screw, 6 x 1/4 P.K.	(36)
.01	41059	screw, 6-32 x 1-1/8	(2)
.04	41069	screw, 6-32 x 1/8, set	(10)
.01	41075	screw, 4-40 x 3/8	(1)
.01	41078	screw, 8-32 x 1/4, brown	(7)
.78	41085	screw, thumb	(2)
.01	41086	screw, 6-32 x 5/16	(40)
.01	41090	screw, 4-40 x 5/16	(52)
.01	41095	screw, 2-56 x 1/4	(4)
.03	41148	screw, 2-56 x 1/8 F.H.	(2)
.07	41151	screw, 8-32 x 1/4, set	(13)
.02	42000	washer, lock, 3/8"	(12)
.01	42001	washer, flat, 3/8"	(15)
.01	42002	washer, lock, #6	(44)
.01	42003	washer, flat, fibre, #6	(4)
.01	42007	washer, lock, #4	(52)
.01	42008	washer, lock, #8	(8)
.01	42021	washer, fibre, #8	(3)
.01	42024	washer, split, #6	(2)
.03	42037	washer, flat, 1/4" I.D.	(2)
.05	42051	washer, lock, "	(2)
.03	42053	washer, lock, #2	(4)
.10	42501	retainer ring	(1)
.05	42520	retainer ring	(5)
.02	43000	ground lug #6	(5)
.02	43006	ground lug #4	(5)
.24	44011	spacer, 1/2" x 1/4" dia.	(1)
.08	46008	foot, large	(4)
.03	46014	grommet, rubber	(1)
.05	46019	foot, 7/8 dia. x 3/8H	(2)
.34	46020	grommet, rubber	(1)
.26	53006	knob	(1)
2.22	53089	knob, tuning	(1)
.91	53090	knob, 3/4" dia.	(11)
.18	56529	clip, crystal	(1)
.09/ft.	58300	spaghetti, thin	
.16/ft.	58301	tubing, 3/4" long	
.06/ft.	58303	spaghetti, thick	
.06/ft.	58416	RG174/U, black	

58446 RG174/U GREEN  
58455 RG174/U ORANGE

PRICE EACH	SYM. #	STOCK#	DESCRIPTION
.20	XV5, 6, 7	97055	7 pin socket (printed circuit)
.25	XV8	97056	9 pin socket (printed circuit)
.17	XV9, 10	97022	7 pin socket
.28	XV14, 15	97041	octal socket
.23	XV16, 11	97047	7 pin socket (shield)

MISCELLANEOUS COMPONENTS & HARDWARE

.01	40000	nut, 6-32, hex	(41)
.02	40001	nut, 3/8-32", hex	(18)
.02	40004	nut, 2-56, hex	(4)
.01	40007	nut, 4-40, hex	(45)
.01	40008	nut, 8-32, hex	(4)
.01	41000	screw, 6-32 x 1/4" B.H.	(4)
.01	41003	screw, 8-32 x 3/8	(1)
.01	41007	screw, 6-32 x 3/4	(2)
.01	41010	screw, 6-32 x 1/8	(1)
.01	41032	screw, 6 x 1/4 P.K.	(36)
.01	41059	screw, 6-32 x 1-1/8	(2)
.04	41069	screw, 6-32 x 1/8, set	(10)
.01	41075	screw, 4-40 x 3/8	(1)
.01	41078	screw, 8-32 x 1/4, brown	(7)
.78	41085	screw, thumb	(2)
.01	41086	screw, 6-32 x 5/16	(40)
.01	41090	screw, 4-40 x 5/16	(52)
.01	41095	screw, 2-56 x 1/4	(4)
.03	41148	screw, 2-56 x 1/8 F.H.	(2)
.07	41151	screw, 8-32 x 1/4, set	(13)
.02	42000	washer, lock, 3/8"	(12)
.01	42001	washer, flat, 3/8"	(15)
.01	42002	washer, lock, #6	(44)
.01	42003	washer, flat, fibre, #6	(4)
.01	42007	washer, lock, #4	(52)
.01	42008	washer, lock, #8	(8)
.01	42021	washer, fibre, #8	(3)
.01	42024	washer, split, #6	(2)
.03	42037	washer, flat, 1/4" I.D.	(2)
.05	42051	washer, lock, "	(2)
.03	42053	washer, lock, #2	(4)
.10	42501	retainer ring	(1)
.05	42520	retainer ring	(5)
.02	43000	ground lug #6	(5)
.02	43006	ground lug #4	(5)
.24	44011	spacer, 1/2" x 1/4" dia.	(1)
.08	46008	foot, large	(4)
.03	46014	grommet, rubber	(1)
.05	46019	foot, 7/8 dia. x 3/8H	(2)
.34	46020	grommet, rubber	(1)
.26	53006	knob	(1)
2.22	53089	knob, tuning	(1)
.91	53090	knob, 3/4" dia.	(11)
.18	56529	clip, crystal	(1)
.09/ft.	58300	spaghetti, thin	
.16/ft.	58301	tubing, 3/4" long	
.06/ft.	58303	spaghetti, thick	
.06/ft.	58416	RG174/U, black	

58446 RG174/U GREEN  
58455 RG174/U ORANGE

PRICE EACH	STK. #	DESCRIPTION
.06/ft.	58448	RG174/U, red
.06/ft.	58450	RG174/U, yellow
.06/ft.	58451	RG174/U, blue
.01/ft.	58504	Bus wire, #18
.12	59312	rubber cushion (2)
16.75	80176	front panel (1)
.06	81175	cable clamp, large (2)
7.50	81438	chassis (1)
1.25	81462	cover, crystal board (1)
1.25	81463	cover, P.A. shield (1)
.50	81464	P.A. shield (1)
.50	81465	bracket, meter (1)
.50	81466	bracket, panel (2)
.50	81467	bracket, relay socket (1)
.50	81468	indexing plate (2)
.50	81986	bracket, ball drive (1)
.50	81987	bracket, switch, large (1)
.50	81988	bracket, small (1)
1.25	81989	cover, VFO (1)
.48	82011	friction drive, brass (1)
2.28	82012	shaft, fibre (2)
1.44	82013	shaft, fibre (1)
.14	82100	cable clamp, small (1)
2.58	83000	flexible coupling (1)
.63	83002	shaft coupling, 1/4" (4)
5.28	84002	ball drive (1)
.29	85000	bushing, hex, 1/4" ID (3)
.14	85001	bushing, Rd. 1/4" ID (2)
.69	85012	bushing, ball drive (1)
6.25	87009	handle (1)
12.50	88139	cabinet (1)
.10	89627	glue capsule (1)
.02	89709	ground strap (4)
4.44	89753	dial, calibrator (1)
3.84	89754	dial, scale (1)
.45	89755	bezel, dial (1)
.45	89756	bezel, meter (1)
5.27	89759	fibre shaft (1)
1.08	89772	cap, friction drive (1)
3.76	97088	socket, relay (1)
.15	97300	shield, tube, 9 pin (2)
.11	97301	shield, tube, 7 pin (2)
.10	97305	shield, 9 pin P.C. (1)
.10	97309	shield, 7 pin P.C. (3)
.23	97712	pilot lamp bracket (1)
.45	98501	plate cap (2)
.02	51300	terminal pin (26)
n/c	89350	label, rear (1)
1.50	66400	assembly manual (1)
1.50	66165	operating manual (1)

To order replacement parts, specify description and part number. Remittance must be made with order, and include \$1.00 for mailing and handling with each order (\$1.50 for each transformer if order includes 1 or more output or power transformers). Prices subject to change without notice.

The entire schematic on 1 long page appears on the following page.

It is followed by three 8.5x11" pages which are the same schematic divided into 3 pieces, so it could be printed on three 8.5x11" pages and then taped together. This is just a convenience for those who do not have the ability to print the entire schematic on a single large sheet of paper.

It is not known whether the penciled-in mark-ups on the schematic and parts list are accurate for all versions of the Eico 753 or only certain serial numbers. They were on the manual when I received it.





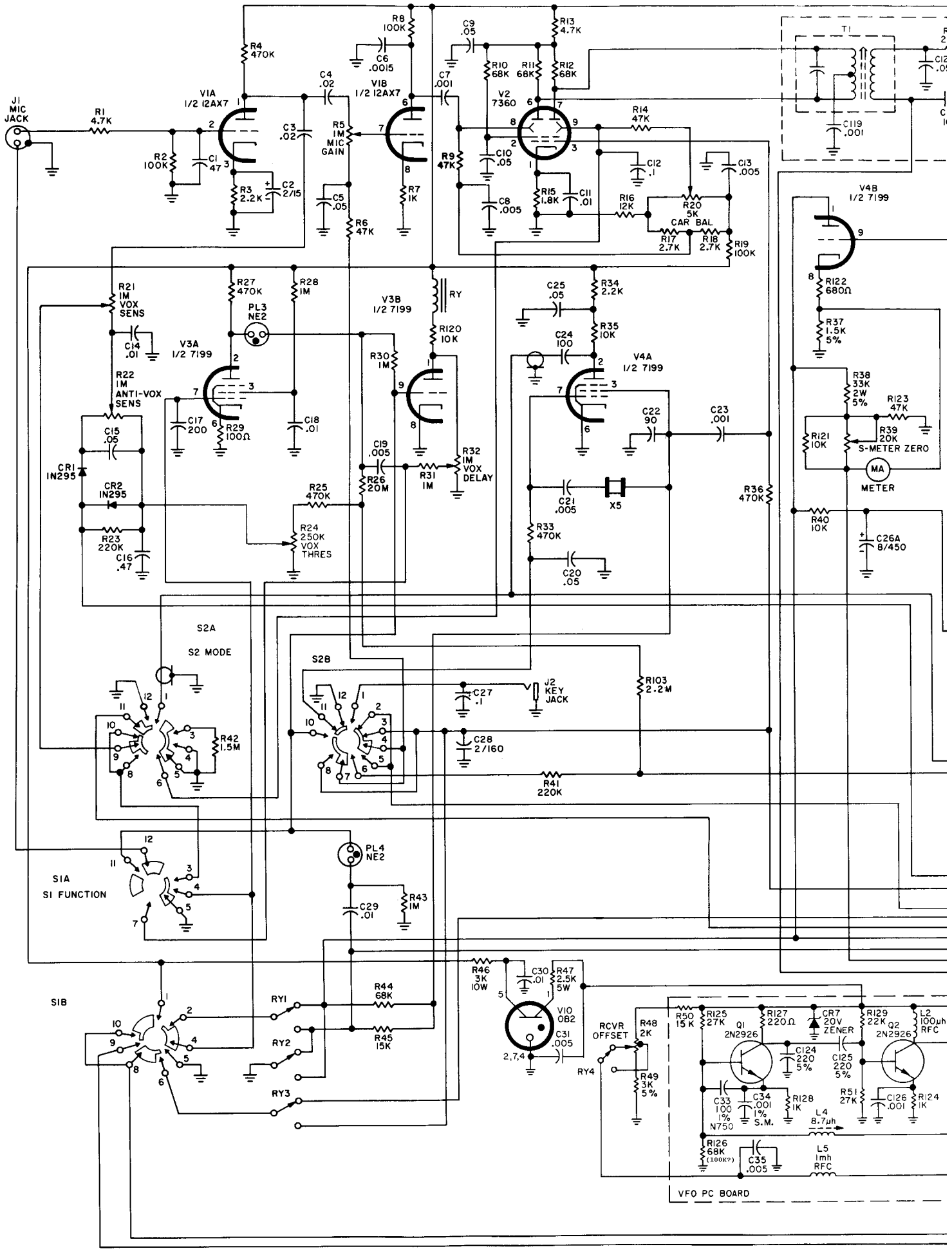

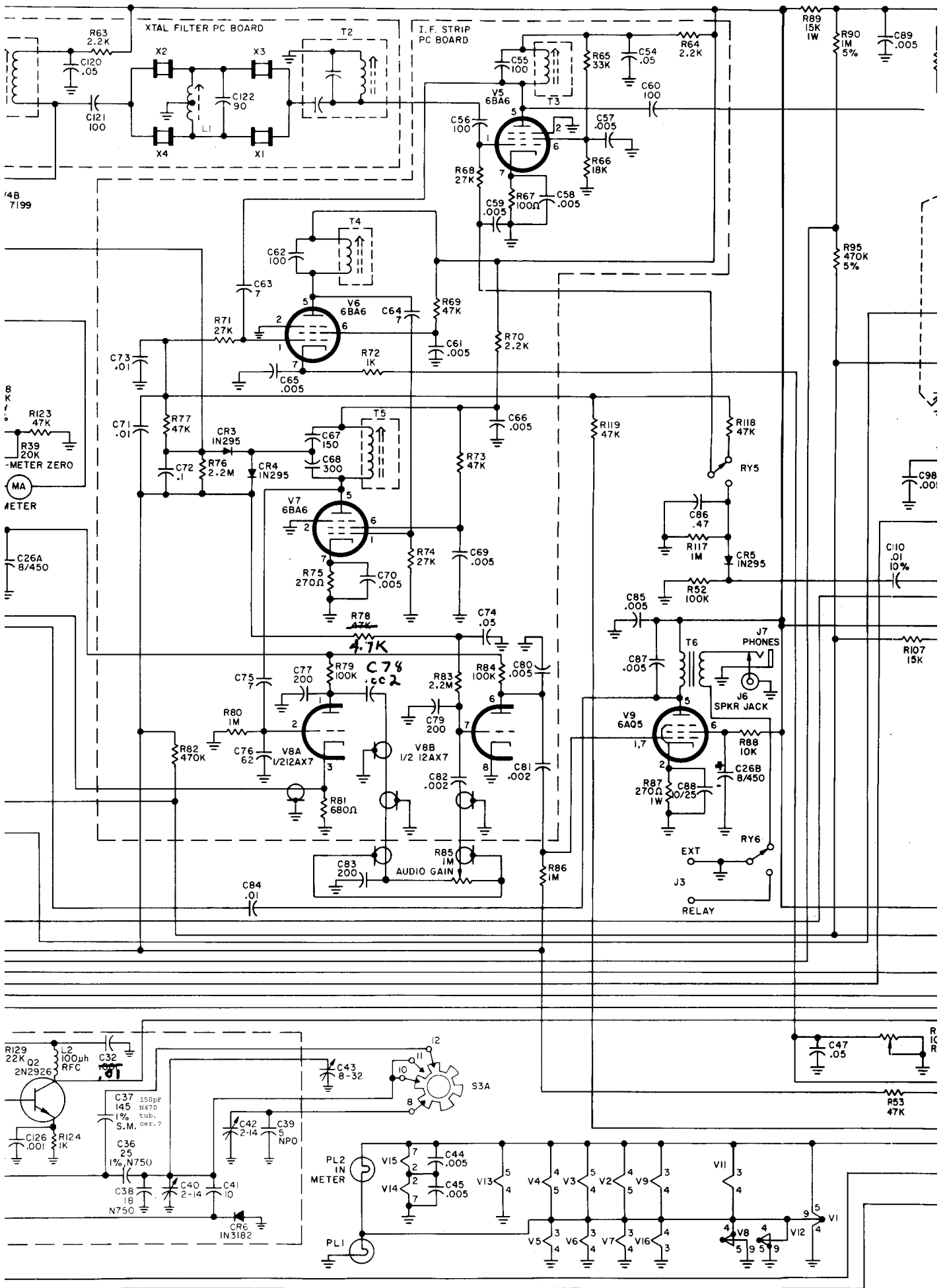

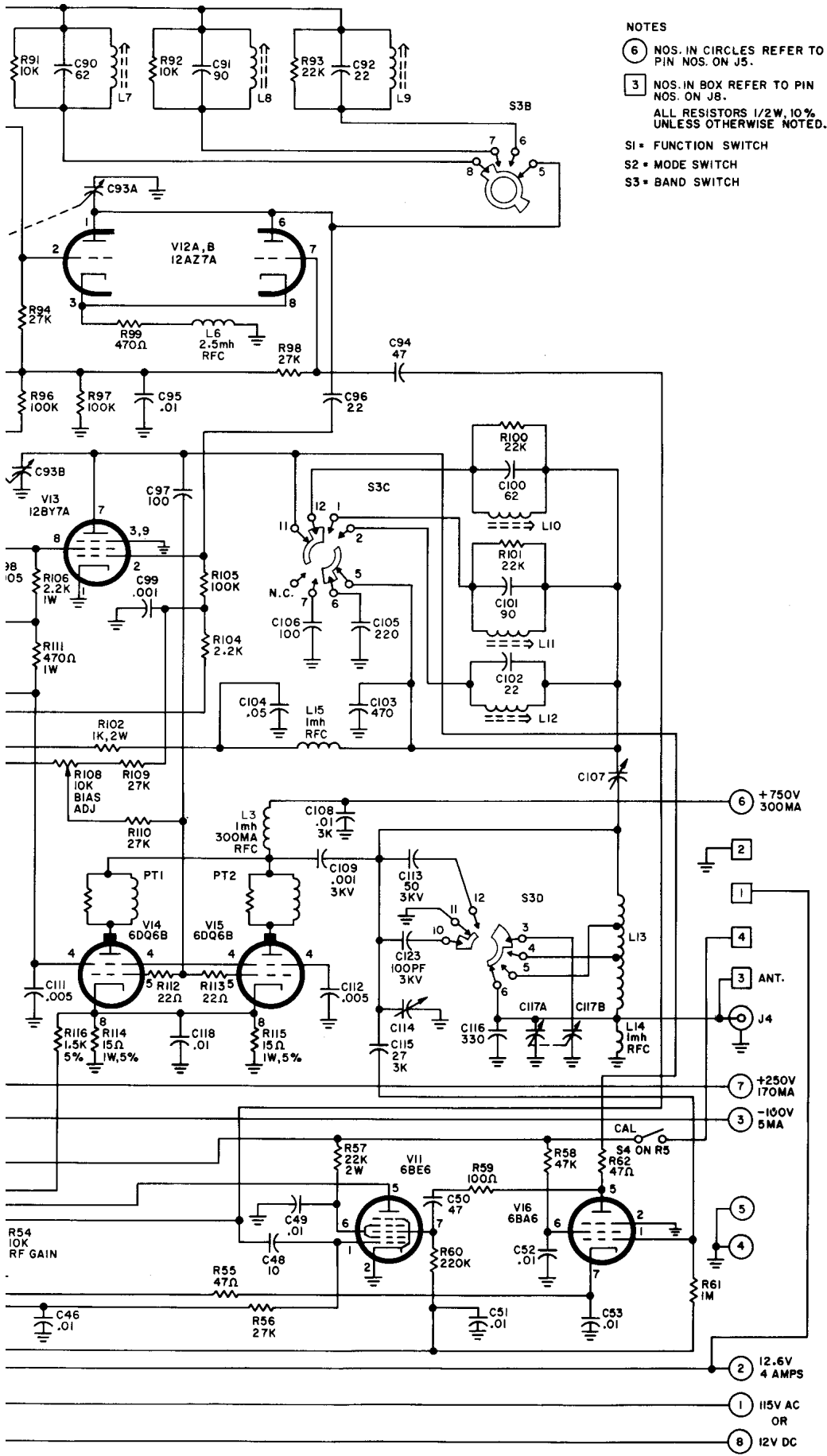

NOTES

6 NOS. IN CIRCLES REFER TO PIN NOS. ON J5.

3 NOS. IN BOX REFER TO PIN NOS. ON J8.

ALL RESISTORS 1/2W, 10% UNLESS OTHERWISE NOTED.

S1 = FUNCTION SWITCH  
 S2 = MODE SWITCH  
 S3 = BAND SWITCH

EICO 753 SCHEMATIC DIAGRAM

EICO-89350



ANTENNA



CALIBRATOR



SPKR

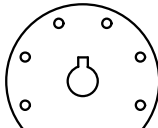

POWER



BIAS

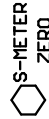

S-METER  
ZERO



VOX  
THRESHOLD

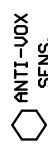

ANTI-VOX  
SENS.

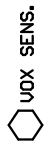

VOX SENS.

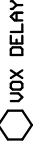

VOX DELAY

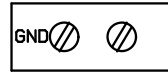

EXT. RELAY



KEY

Since 1945, EICO has been recognized as a leader in the design and manufacture of electronic products in kit form. The wide range of equipment that EICO has made available covers nearly every phase of electronics—High Fidelity (Receivers, Amplifiers, Tuners and Speakers); tape recorders; test instruments, Citizen Band and Amateur Radio and Transistor Radios.

There is virtually no area of our every day life where EICO Products do not make a contribution. For there are more than 3,000,000 EICO Electronic Products in use in American homes, industry, military as well as in Federal, State and local Government. In the Nation's schools, EICO Test Instruments and training aids make it easier for students to learn about electricity and electronics.

EICO's 20 years of growth is a matter of public record. Responsible for this growth is the company's strict adherence to its policies of top quality products at reasonable prices. The Company's recent move to a modern 110,000 square foot plant marks the beginning of another era in EICO product development and contribution to the Nation's economy.

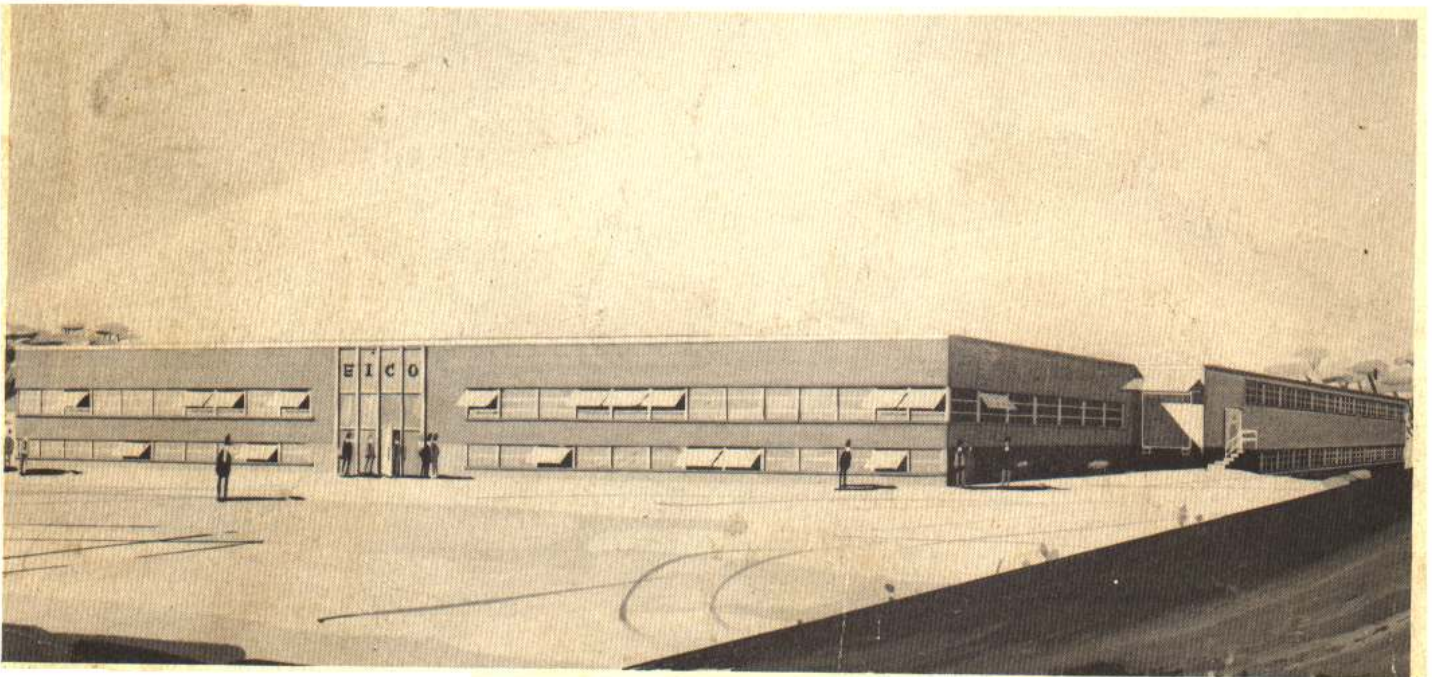

Eico Electronic Instrument Co., Inc., 131-01 39th Avenue, Flushing, N. Y. 11352