

GALAXY V

MK 2

ADDED FEATURES !

- * 400 WATT SSB POWER
- * SOLID-STATE VFO
- * VERNIER LOGGING SCALE
- * CW BREAK-IN OPTION
- * CW SIDETONE AUDIO
- * CW FILTER OPTION
- * NEW ATTRACTIVE STYLING

(010167)
(020267)

Manual # 183-60
Price \$2.00

PAGE 1

GALAXY V MK2

TABLE OF CONTENTS

SECTION I...	Unpacking & claims.
SECTION II...	Location & description of controls.
2-4...	Microphone & power connections.
SECTION III...	Set-up adjustments.
SECTION IV...	Operating the equipment.
4-1...	Receiving only.
4-2...	Tune-up.
4-3...	CW operation.
4-4...	SSB operation.
4-7...	Mobile tune-up
4-8 & 4-9..	Mobile installation & use.
SECTION V...	Circuits
5-1 to 5-4..	Block diagram and analysis.
SECTION VI...	Charts.
6-1...	Tube voltage chart.
6-2...	Transistor voltage chart.
6-3...	Tube resistance chart.
6-4...	Chassis top layout and locations.
6-5...	Converter alignment locations.
6-6 to 6-14..	Alignment information.
SECTION VII.	Service information
7-1...	Required information.
7-8 & 7-4..	Ordering parts.
7-5...	Returning equipment.
SECTION VIII.	WARRANTY .
SECTION IX...	Parts listings.
SECTION X...	Schematic(last page in the manual)

Warning

DO NOT make connections or attempt to operate this equipment until the special notes below are read and understood.

- 1.... Remove the top and bottom of the cabinet. Remove all hold-down tape; check to insure proper seating of all components, etc. IMMEDIATELY on receipt.
- 2.... IMMEDIATELY inspect for any signs of internal or external damage. If any found, contact the delivering carrier for joint inspection IMMEDIATELY.
- 3.... This set requires an 8 OHM speaker for best results. See note #4 on page 19, and SPEAKER on page 8.
- 4.... See VOX on page 8. Turn unit OFF before inserting. VOX plugs into socket OPOSITE direction than old models.
- 5.... See EXT. on page 8 for external control circuits.
- 6.... See 2-5, page 10 before connecting an antenna.
- 7.... See 3-1, page 10, before connecting power supply.
- 8.... See 3-2, page 10, before attempting to transmit.
- 9.... See page 16 about starting car with DC supply used.
- 10... If you have an old Remote VFO having a number lower than 6110 for the first four digits, write for bulletin on necessary changes before using. (RV1 or RX2)
- 11... All accessory equipment made for the Galaxy III or Galaxy V may be used in the Galaxy V MK2 without change, except the RV1, RX2 and NOX1, which may be used with minor wiring change, and the VOX which MUST be the late model VOX35C.

(101667)

(010167)

GALAXY V MK2

SECTION 1

UNPACKING

1-1. . . . It is assumed the user has now removed the GALAXY V MK2 from the carton and has had an opportunity to make a brief inspection. NOTE! There is normally a special WARNING sheet packed with the equipment, bringing to your attention several very important notes and points of inspection to be made immediately, and before any attempt is made to connect or operate the equipment. **BE SURE THESE WARNINGS ARE HEEDDED!!!!!!!**

1-2. . . . DAMAGE: This equipment has been carefully packed for safe arrival, providing it was properly handled enroute to you.

(a) OBVIOUS DAMAGE

If the carton showed obvious signs of rough handling you should have made a note to this effect on the delivering carriers receipt. If later inspection shows loose parts, broken parts, or any other signs of malfunction that could be even remotely due to shipping damage, contact the delivering carrier immediately and have his representative make a joint inspection with you and provide you with a copy of the inspection made. This form does not assign responsibility for damage, nor is it a claim on the carrier, but prepares a foundation on which a claim can be filed later in the event that it is determined that any damage or malfunction was attributable to shipping damage. Neither may the carrier decline to make such inspection, or his inspecting representative assign any liability at this time. In some cases it may be then be necessary to return the equipment to your dealer or the factory for a more complete examination.

(b) HIDDEN DAMAGE

In many cases the carton may not show any appreciable signs of rough handling externally, but it is still possible that considerable internal damage can occur. The procedure for inspection, etc. is still the same.

Remember, the responsibility for safe delivery rests with the carrier. The responsibility for instigating action that will enable the carrier to settle any subsequent claims rests with YOU. Prompt action on your part will minimize delays. In no event should you return any damaged shipments before proper claims preparations have been made. To do so can jeopardize your investment. Contact your dealer or the factory for assistance, if needed.

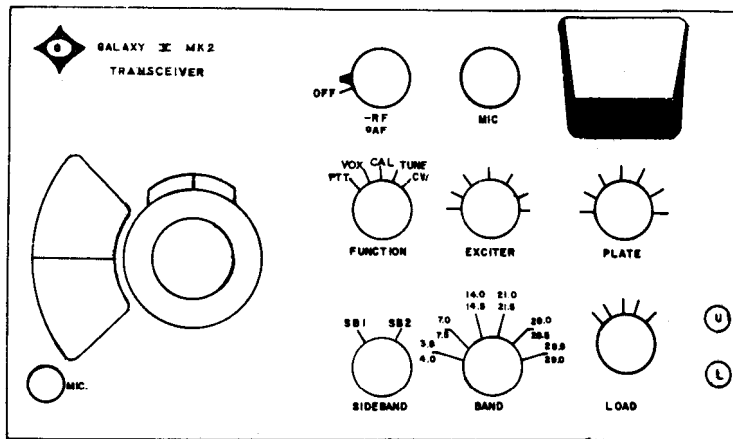

2-1..... LOCATION OF FRONT PANEL CONTROLS*

- o-AF AUDIO GAIN at the top of the panel. The knob part controls audio level. When this knob is maximum counter-clockwise it opens the primary power switch to turn off all power to the equipment.
- OFF
- RF RF GAIN, which is a lever control under the audio knob. Normally left in the maximum clockwise position for full sensitivity. For exceptionally strong signals, it may be set in a counter-clockwise direction to increase the AVC threshold level, as desired. As retarded, the "S" meter level will increase, which is the selected AVC threshold level, and only signals of this strength, or greater, will indicate.
- FUNCTION A five position selector switch to select mode of use.
- PTT Allows keying of unit to a transmit condition by the microphone switch, or by another switch connected to the duplicate PTT jack on the rear panel. No VOX use in PTT setting.
- VOX The unit may be placed in a transmit condition by the VOX accessory now, as well as with PTT, providing the VOX accessory is installed and adjusted.
- CAL Turns on the internal 100 kHz calibrator, providing this accessory is installed. Otherwise, same as VOX position.
- TUNE Automatically places the unit in a transmit condition at reduced power input. NOTE! The SB selector switch must be in the SB2 position, and the MIC gain control fully clockwise. (See note #1)

- CW** Position for normal, full power CW operation. However, when placed in this position the unit will still be in a receive mode until placed in transmit mode by closing the PTT line with an external switch (mic. ptt or other switch on the rear ptt jack), or by the VOX accessory when this accessory is installed and adjusted and cw key also closed. Will remain in transmit when ptt closed, or hold a few seconds with the VOX and key, depending on adjustment of the VOX hold time selected. (See note #1)
- EXCITER** Tunes both the final driver and receiver antenna input circuits to resonance.
- PLATE** Tunes the final amplifier circuit to resonance.
- LOAD** Matches the final plate circuit to the antenna load presented, within the matching range of the Pi-network, which is 40-100 Ohms, resistive.
- SIDEBAND** Serving two functions, this switch inserts carrier into the filter passband for tune or cw positions of the function switch, when in the SB2 position. On other function switch settings it serves to select upper or lower sideband operation, as indicated by the "U" or "L" panel lights on the right side of the panel
- MIC** Also serving two functions, this control should be set to maximum clockwise position in the tune position of the function switch, and fully counter-clockwise for the cw position of the function switch. On any other function switch position this operates as a transmit microphone gain control. The setting then is what-ever is required to maintain voice peaks at the "tune" mark on the meter.
- BAND** Selects desired freq. range in 500 kHz steps. NOTE! Colors correspond to color on VFO dial with blue on 14.0-14.5 MHz range only.
- VFO** Calibrated in primary marks of 5kHz steps, but may be interpolated with vernier logging scale on tuning knobs. Dial reading added to lower MHz number on bandswitch- (ie:) 200 on red scale on 75-80 meters is added to lower value of 3.5 MHz--3.5 plus 200 equals 3.7MHz., etc.

NOTE #1 AUDIO SIDETONE is generated when the function switch is in the TUNE position and the hand key closed (or the key unplugged which shorts the cw keying jack). It is also generated when the function switch is in the CW position, the PTT circuit closed, and the key closed or unplugged.

MIC The microphone jack is in the lower left hand corner of the panel. It requires a small, 3/16" dia. plug, such as the Switch-Craft S-260, the military PL68, or equal. The tip is PTT, the ring is audio, and the barrel is ground.

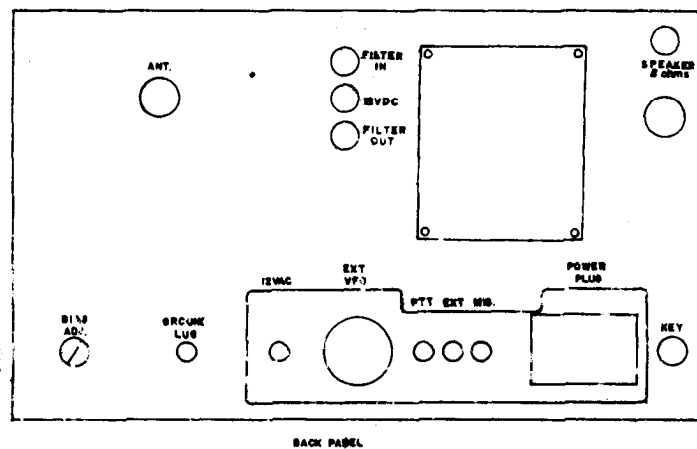

2-2. LOCATION OF REAR PANEL CONTROLS & JACKS
(lower connections, etc.)

BIAS ADJ. Potentiometer to set bias on final tubes.

GROUND LUG Grounding bolt for external grounding connection.

12VAC Provides 12 volts AC fixed use; normally for illumination of meter in DAC35 Deluxe Console. Will supply 12VDC in mobile also, and may be used for other purposes, so long as current drain does not exceed 1/2 Ampere.

EXT VFO Provides power and control circuitry for Remote VFO, NOX1, etc. Supplied with a jumper plug installed, which is removed to connect accessories.

PTT A jack in parallel with the PTT connection on the microphone jack. May be used for foot switch, etc.

- EXT** A jack to actuate other equipment in unison with the transceiver. Provides a ground on the center part of this jack when the transceiver is in the transmit mode. DO NOT apply over 70 volts AC/DC, or over 1 Amp. through these contacts. NEVER key 115VAC lines.
- MIC** A jack that is in parallel with the front panel microphone circuit; normally used for patch connections, etc.
- POWER PLUG** Main power connection for the power supply; fixed-mobile.
- KEY** A standard 1/4", closed circuit phone jack. For CW operation insert a key here.
(upper panel jacks, etc.)
- ANT** A standard SO239 coax jack. Requires a PL259 plug for the antenna connection.
- CW FILTER** Three jacks for connection of the Galaxy F3 selective filter. Internal jumper from in-out must be cut to use. Three matching cables from the F3 filter plug-in.
- SPEAKER** For connection of usual, external PM speaker. NOTE! An 8 Ohm speaker should be used. However, if you have a 3-4 Ohm speaker, it may be used at lower volume levels, or at maximum volume level with a series 4-6 Ohm resistor.
- (hole) Located under speaker jack, this hole is to pass the RF cable from the remote VFO to the internal VFO input jack.
- 2-3. . . . LOCATION OF INTERNAL ADJUSTMENTS (top removed)
- VOX** This accessory is plugged into the oblong, multi-contact socket located on the left edge of the chassis, as viewed from the top-front of the unit. NOTE! The VOX board is reversed from the earlier model, and the unit must be plugged in with the controls to the OUTSIDE of the transceiver. Refer to VOX manual for adjustment. NOTE! Jumper strip installed originally, which must be inserted in lieu of VOX, or unit will not go into transmit.

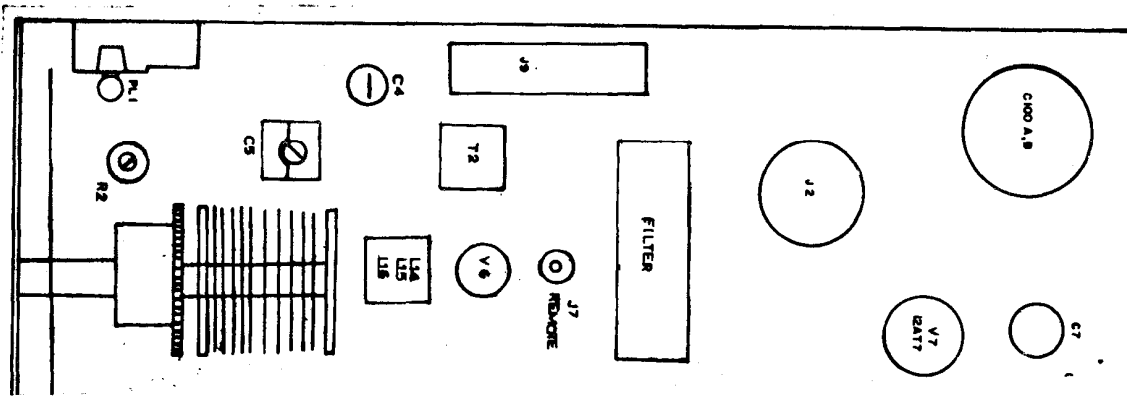

- "S" METER** A screwdriver adjusted potentiometer, located on the top of the chassis near the VFO pilot bulb, R2. See "set-up adjustments" for use.
- CALIB.** An octal socket, J2, on the top of the chassis, on the left side, near the rear, as viewed from the front-top. No jumper plug required when removed. Freq. adjustment for the calibrator is on the calibrator chassis.
- NOTE!** Other internal controls and adjustments should not be moved unless there is a malfunction, and then only when such adjustment obviously needed and the operator is sufficiently familiar with the procedures. Many field problems are caused by "peaking" all the slugs when a problem does not relate to such adjustments.
- 2-4. . . .** CONNECTIONS FOR POWER-MIC-ETC.
- MICROPHONE** There are two microphone jacks. The panel jack, J3, is normally used and requires a plug such as Switch-Craft S-260, or equal. This is similar to the military PL68, and has a slightly smaller diameter barrel of 3/16". Connect ground to the (shield) barrel of the plug. Connect audio to the ring (isolated part behind the tip). Connect the PTT lead to the tip of the plug. Most microphones have just three wires; if yours has four wires, connect the common of the audio and PTT systems together, and these go to the barrel of the plug.
- NOTE!** Some microphones have a PTT switch wired so the microphone element is shorted out when the PTT switch is in the "off" condition. If this is found, then the "short" must be eliminated or VOX operation will not be possible. The other microphone jack is on the rear panel, marked MIC., and in parallel with the front jack. It may be used for any desired application, but usually used with the DAC35 Deluxe Accessory Console for the phone patch input.

POWER The main power cable requires a Cinch type S-312CCT connector. This is part of the Galaxy power supplies. The power connector pins are, respectively :
 #1- High B plus, #3-Low B plus, #5- 12VDC positive, #6-12VAC/DC , #7-Ground , #9- Bias negative, #11 & #12 each one side of the main power switch for primary power control, fixed or mobile use.

**ANTENNA
 CONSIDERATIONS**

2-5. . . . We know you are anxious to operate--but wait! Is the antenna to be used really suitable? Usually, an SWR under 2:1 will be suitable---but not always. The Galaxy is designed to match 40-100 Ohms resistive , and this must be presented by your antenna, irrespective of any SWR value. A moment to check may save later trouble.

SECTION III

3-1. . . . **SET-UP ADJUSTMENTS**

The very first connection, and a very important consideration, is to have a good ground connection to the transceiver. A grounding bolt is provided on the rear. The AC line is bypassed in the Galaxy supply, and lack of a ground will result in a slight shock between the equipment and anything grounded. Also, lack of a good ground will often result in improper operation in several respects, including TVI.

3-2. . . . **BIAS SETTING**

Place the function switch in the PTT position. Turn the unit on with the AF gain control switch and allow a 5 minute warm-up. Set the MIC gain control maximum counter - clockwise. Set the SB selector switch to SB1. Set the BIAS potentiometer(rear panel view) maximum counter-clockwise. Close the PTT circuit and adjust the BIAS control until the panel meter indicates S4-1/2(between S4 and S5). Open the PTT switch. In any change of line voltage, or changing from fixed to mobile, re-set this bias adjustment. If in doubt, check.

3-3.... "S" METER ZERO SET

Remove the top cover by removing the screws on the side of the cabinet. CAUTION!!!! HIGH VOLTAGE !! The "S" meter zero adjustment is a screwdriver adjustment potentiometer, R2 , located on the chassis near the VFO pilot light bulb. See the chassis view in the previous section II. After the unit has been on for several minutes, and without an antenna connected, but with the exciter tuning control "peaked" for maximum received noise, adjust R2 so that the meter rests at the extreme left marking. This gives the "truest" "S" meter reading, and shows atmospheric noise levels.

3-4.... ACCESSORY INSTALLATION

If a calibrator is to be installed it should now be plugged into the octal socket J2.

If a VOX is to be installed, FIRST TURN OFF THE AC primary power. Remove the jumper strip board from the socket J9. With the VOX positioned so the control side of the board is to the outside of the case, insert it in socket J9 until it is firmly seated for good contact along it's full length. Primary power may now be restored and the cover replaced.

SECTION IV EQUIPMENT OPERATION

4-1.... RECEIVING

To receive only, just adjust the exciter tuning control for best signal strength.

4-2.... TRANSMITTER TUNE-UP

After some time of use the operator will become familiar with the adjustments and can do them quickly. Until this familiarity is obtained, the operator should read all steps in tuning thoroughly, and do them as quickly as possible. If a step or adjustment is forgotten, place the unit in a "stand-by" condition a moment while re-reading and do not keep the unit on in an untuned condition.

- (a) (Place the SB selector to SB2.) (Set the MIC gain fully clockwise.) (Set the LOAD control fully counter-clockwise.) (Close the CW key, if used.) (Function switch to PTT.)

It is suggested the following tuning be done with the equipment connected to a "dummy" 52 Ohm load, rather than an antenna, to minimize "QRM on the air".

THE NEXT STEPS WILL PLACE THE UNIT IN A TRANSMITTING CONDITION. COMPLETE STEP (b) QUICKLY, AND (d) AND (e) PROMPTLY .

(b) Function switch to TUNE position -----

EXCITER tuning for maximum meter reading -----

PLATE tuning for minimum meter reading -----

If the meter reading is above the "tune" mark on the meter STOP and go to the PTT position. See note #2.

If the meter reading is below the "tune" mark on the meter proceed with step (c). The unit is now in a resonant, lightly loaded condition.

(c) Adjust the MIC gain counter-clockwise until the meter drops about 25%, then retune the EXCITER for a more precise peak meter reading. Return the MIC gain to maximum clockwise setting.

(d) Adjust the LOAD control clockwise until the meter rises to the "tune" mark on the meter, then quickly adjust the PLATE control for a minimum meter reading again. It should now have a higher minimum than before.

(e) Repeat step (d) until the minimum, after retuning the PLATE, is at the "tune" mark on the meter . This is referred to as "loading" and "dipping"; the object being to get the last "dip" of minimum current at the "tune" mark on the meter.

If the completion of step (e) allows "dipping" at the "tune" mark on the meter, then tuning is complete and go to the PTT position. However, if the LOAD control reaches a fully clockwise position and you are unable to "dip" at the "tune" mark-STOP and go to PTT. Then see note #3.

NOTE #2 A "dip" of minimum which results in the meter above the "tune" mark at this point indicates that the antenna impedance is below that which this Pi-network can match.

NOTE #3 Being unable to increase the "dip" to the "tune" mark with maximum clockwise setting of the LOAD control indicates the antenna impedance is above that the Pi-network can match.

In either case, results as indicated in note #2 or #3 indicates the antenna is not suitable for this equipment and corrective action must be taken at the antenna. Retuning of the antenna, or a matching device, will be necessary.

Assuming there was no trouble loading the antenna, the equipment is ready to be operated on SSB or CW.

4-3... CW OPERATION

CW operation is available in two modes; Low power manual operation ; High power manual or VOX-break-in operation.

(a) LOW POWER - MANUAL CW OPERATION

After completion of step (e) in tuning, just operate the key to send CW. When done transmitting, return the function switch to PTT position. This will be at approximately 150 watts input. It is recommended that the microphone be un-plugged from the panel if this method is used.

If you wish to reduce power even more than above, just set the MIC gain control in a counter-clockwise direction, which will reduce the power input, and this may be done to obtain any power input level desired down to a fraction of a watt.

(b) 300 WATT -MANUAL CW OPERATION

This method is normally used when the VOX is not used, as required for break-in operation. The microphone should be plugged in as a convenient means of placing the unit in transmit condition with the PTT switching. The setting of the MIC gain control does not control power in CW mode, and it should be set fully counter-clockwise in CW mode.

After completion of the tuning step (e), open the key contacts. Place the function switch to CW position. The unit will now be in a receiving condition. To transmit, close the PTT with the microphone and operate the key for CW. Open the PTT to return to receiving. (Or connect a foot switch to the rear panel PTT jack).

(c) 300 WATT - BREAK-IN CW OPERATION

This method of operation requires that a VOX be installed and correctly adjusted. Refer to the VOX manual for correct adjustment.

When tuning step (e) has been completed, open the key contacts. Place the function switch to CW mode. Now, when you close the key the unit will automatically go into a transmit condition; It will remain in transmit a second or two, as determined by the "hold-time" setting of the VOX unit, then return to a receiving condition. Adjust the VOX "hold-time" as desired, however, there is a slight "click" generated in the speaker each time the set goes from transmit to receive, and to minimize this we suggest a "hold" of about a second may be desirable.

4-4. . . . SSB OPERATION

- (a) After tuning step (e) is completed, return the function switch to PTT or VOX positions, as desired. Set the MIC gain to a maximum counter-clockwise position. Select the desired sideband; indicated by the lighted panel lamps on the right side.
- (b) Place the unit in transmit with the PTT on the microphone, or speak into the microphone to operate the VOX when in VOX position. The VOX will actuate the unit at any setting of the MIC gain control. Adjust the VOX unit as necessary for VOX gain, anti-VOX, and hold time.
- (c) While speaking into the microphone, advance the MIC gain in a clockwise direction until voice peaks swing the meter up to the "tune" mark on the meter. This represents full SSB power.
- (d) The exact setting of the MIC gain control is of no importance. It's setting depends on the output level of the microphone in use, and the volume level of the voice. A high output microphone may need only slight advance of the MIC gain control (a microphone rated at - 45DB is very high output). A microphone that has low output may require the MIC gain control to be set fully clockwise (a microphone rated at -60 DB is a low output microphone). Most high output microphones are prone to "peak" in the higher voice frequencies. One with output about -55 DB is a good all around choice, but any microphone that will allow the unit to be driven to full input may serve the purpose.

4-5.... NOTE! You will hear a "tone" in the speaker or headphones when-ever you have the set in TUNE or CW setting of the function switch, and the "key" closed. The volume will be regulated with the same receiving volume control.

4-6.... NOTE! NEVER TUNE THE SET WITH THE FUNCTION SWITCH IN THE CW POSITION. ALL TUNING IS TO BE DONE IN THE TUNE SETTING, AS INDICATED IN SECTION 4-2 .

4-7.... MOBILE TUNE-UP

Tuning is the same in all respects for mobile operation as in fixed operation, and done in accordance with section 4-2. However, there are two points of interest that should be mentioned. When changing the set from fixed to mobile use, be sure and re-set the bias on the final. Most mobile antennas are rated for SSB power only, which averages out to a relatively low power. They may fail if you operate the set in tune or cw over a period of several minutes, and most will certainly de-tune if carrier is left on for several minutes.

4-8.... MOBILE INSTALLATION

We believe the pictures below typify installation of the Galaxy V mk 2 transceiver in an automobile, under the dash. The MMB mount is a very universal bracket, and one which permits fast, easy removal from the car. Additional details are provided with the mount.

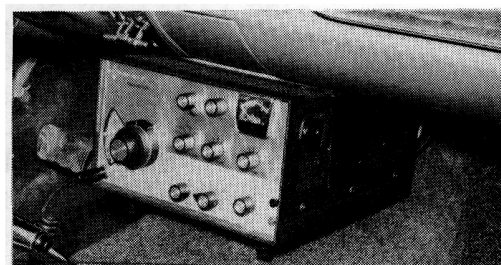
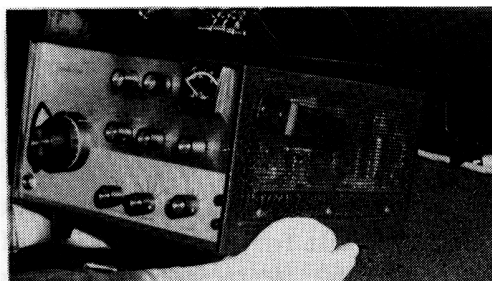

The transistor circuits are well designed for operation in a warm environment but ---- on a sunny, warm day, the heat in a car with the windows closed can build up to great levels. In this event, you should open the windows a moment to allow dissipation of heat build-up before operating.

4-9. . . . DC SUPPLY CONSIDERATIONS

The DC supply should be mounted as near the battery as possible. The Galaxy supply has the primary cables attached, and under no circumstances should the supply be mounted so that an extension to these cables is required.

It is generally desirable that the DC supply be mounted high on the inside of the fender, and near the battery. This will position it out of direct water splash in most cases, and also be in about the best position for ventilation. Do not mount near the firewall as this is the "heat trap" in the motor compartment.

The worst condition for a DC supply is to operate the set while driving at high speed, building up considerable heat in the motor compartment (even in rather cool weather-- but especially so in hot weather), then stop for gas, etc. and turn off the motor. The heat build-up in the motor compartment is terrific without the motor fan in operation in this case. If you find it necessary to stop and turn off the motor, then the DC supply should be shut-down as well until the heat level has been reduced by opening the hood, etc., or starting the motor for added ventilation.

NEVER start the motor with the DC supply in operation !
Turn off the DC supply until the motor is running.

The cable carrying power from the DC supply to the unit should not be over 10' in length with the cable supplied. If slightly more length is necessary, then an added #18 wire should be paralleled with the wire that carries the filament power. (Pin #6 on the Galaxy V MK2).

An additional bracket, called the ZMM is also available. It is used for floor mounting the regular mobile mount, and will provide a high angle tilt for easy viewing of the panel. The ZMM is priced at \$3.00 through your distributor.

5-1.... THEORY OF OPERATION - BLOCK DIAGRAM

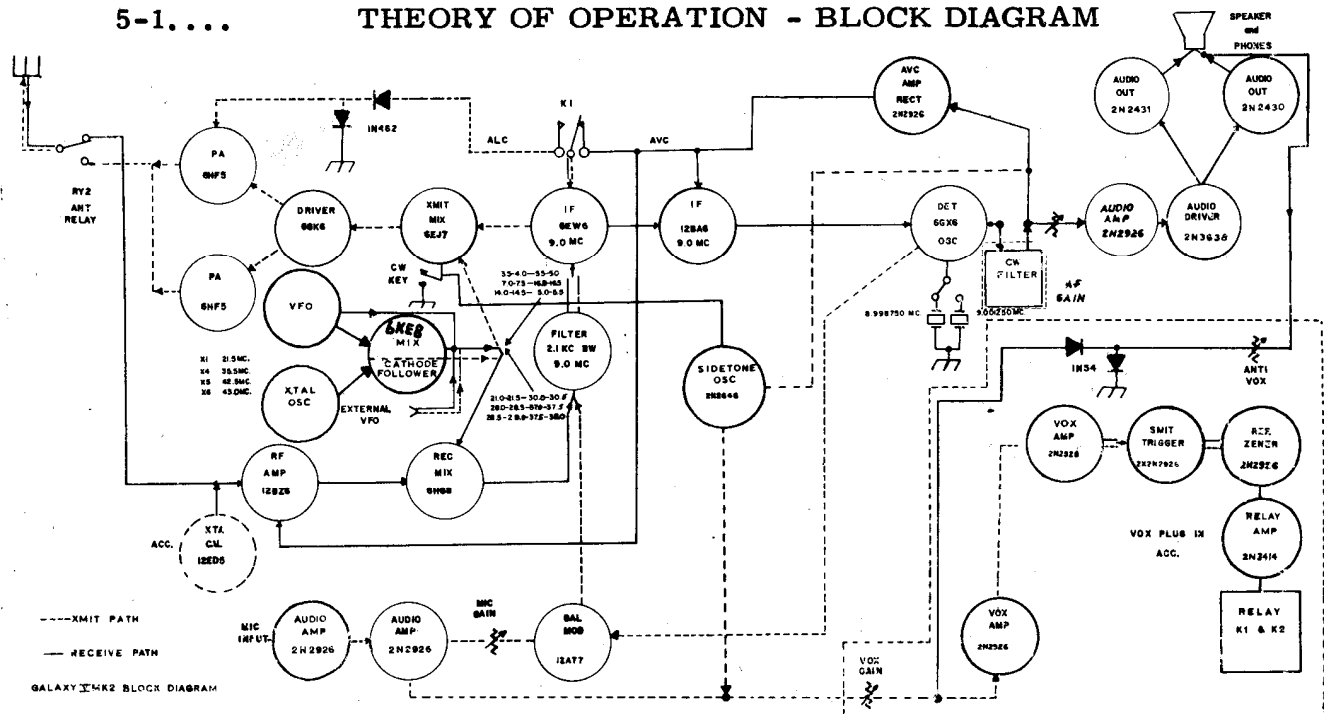

5-2.... GENERAL CIRCUIT ANALYSIS FOR TRANSMITTING

The voice signal from the microphone is coupled to the two 2N2926 transistors (back panel) for amplification, then coupled to the 12AT7 balanced modulator tube. A signal from the 6GX6 carrier oscillator tube is also coupled into the balanced modulator tube, and this signal will be on 9,001,250 kHz (SB2 position) or 8,998,750 kHz (SB1 position), depending on the band in use. The audio and RF signals are combined in the 12AT7 balanced modulator tube and the resultant output is double sideband, suppressed carrier.

The double sideband, suppressed carrier signal is then coupled into the crystal filter. As the filter bandpass is restricted, it will only allow one of the sidebands to pass to its output terminals, which completes the generation of an SSB signal. The filter output is then coupled to the 6EW6 I.F. amplifier stage, then to the 6EJ7 transmit mixer tube.

A signal from the VFO, in the range of 5.0 to 5.5 MHz is coupled to the transmit mixer tube for operation on 80-

THEORY OF OPERATION - BLOCK DIAGRAM

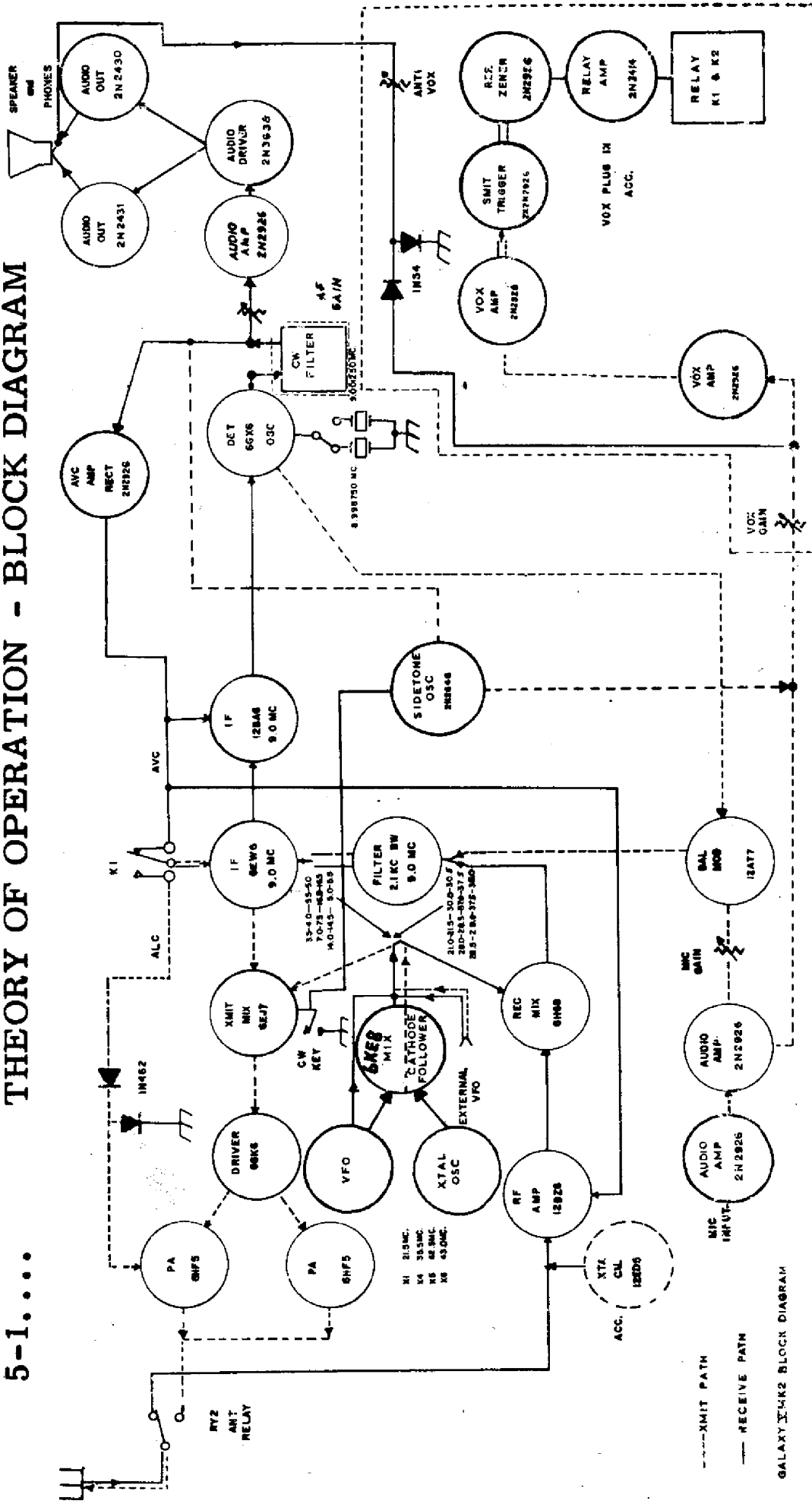

GALAXY TMK2 BLOCK DIAGRAM

20 meters, or from the 6KE8 mixer tube for operation on the other bands, with output from the 6KE8 in the range of 16.0 -16.5 mHz for 40 meter operation; 30.0-30.5 mHz for 15 meter operation; 37.0-38.0 mHz for 10 meter operation. The sum or difference frequency, as required for the band of operation is selected by the tuned circuits. This signal, along with the 9 mHz signal, is combined in the 6EJ7 transmit mixer to produce the signal on the desired operating frequency and is coupled to the 6GK6 driver stage. The 6GK6 drives the parallel 6HF5 output stage.

The 1N462 rectifiers are coupled to the grid circuit of the 6HF5 tubes and detect any trace of grid current flowing, and couples this as a negative ALC voltage to the 6EW6. Thus, when-ever grid current does flow, the gain of the 6EW6 stage is automatically reduced to maintain linearity. This will minimize distortion and increase "talk-power".

The plates of the 6HF5 tubes are connected in parallel and matched to the antenna output through an adjustable Pi-network.

In CW operation the carrier oscillator is shifted to 8,999.45 kHz for carrier insertion into the filter bandpass, and the 6EJ7 is grid-block keyed.

5-3....

GENERAL CIRCUIT ANALYSIS FOR RECEIVING

The incoming signal is switched through the antenna relay, then coupled into the 12BZ6 R.F. amplifier stage. The output of this stage is coupled to the 6HG8 receiving mixer tube. A signal from the VFO in the range of 5.0-5.5 mHz for 80-20 meter operation is also coupled into the 6HG8 mixer tube; or in the range of 16.0-16.5 mHz for 40 meters; 30.0-30.5 mHz for 15 meters; 37.0-38.0 mHz for 10 meters.

The output of the 6HG8 is coupled to the 9 mHz crystal filter, with the bandpass of this filter determining selectivity. The output of the filter is coupled to the 6EW6 I.F. amplifier; it then coupled to the 12BA6 second I.F. amplifier, and that tube's output coupled to the 6GX6 product detector tube.

The output of the 6GX6 is low-level audio, and this output is coupled to the AVC rectifier and audio amplifier. A 2N2926 serves as the AVC rectifier, and it's DC output

is a negative voltage coupled to the first receiving R. F. stage, and the first and second I. F. amplifier stages, controlling the gain of these stages. The audio from the 6GX6 is also amplified by a 2N2926, then by a 2N3638. The output from this last driver stages operates a complimentary pair of transistors, a 2N2430 and 2N2431, which delivers audio to the speaker.

NOTE #4. . NOTE! This set was designed for optimum performance using a 8 Ohm PM type speaker. A 3 or 4 Ohm speaker may be used, but distortion will be noticable at high volume levels. Placing a resistor of about 4 Ohms in series with a 3 or 4 Ohm speaker will minimize distortion at small loss of volume.

5-4. . . . VOX CIRCUITRY

The VOX is an optional, plug-in unit, as shown by the dotted lines on the block diagram.

A portion of the audio is taken from the second microphone amplifier and coupled to the first 2N2926 VOX amplifier, which drives the second VOX amplifier; also a 2N2926 . A 2N2926 is used as a level reference zener diode, and when input reaches this pre-set level a pair of 2N2926s used in a "trigger" circuit quickly conduct and drive the 2N3413 relay amplifier. This "trigger" circuit is much more positive in action than the usual VOX circuitry, and will minimize "chattering" around a critical point of operation.

When operating CW, the keying circuit operates the side-tone oscillator, and it injects a strong audio signal to operate the VOX for "break-in" action. NOTE!!!! When using the VOX for CW, you will find operation better if the VOX GAIN is set higher and the ANTI-VOX GAIN set lower than when using voice operation.

The ANTI-VOX circuitry can reject unwanted signals only to a degree, and excess audio from the speaker may cause the VOX unit to cycle on and off. The three proper steps to stop this are: Reduce speaker volume ; increase ANTI-VOX setting ; decreasing VOX gain setting. (Keeping the microphone further from the speaker has the same result as the lowering of audio level.)

6-1.... VOLTAGE CHART

PIN	1	2	3	4	5	6	7	8	9	10	11	12
V1-12BZ6	-.3	.6	0	-	300	100	0	-	-	-	-	-
	-	150	-	-	300	300	-	-	-	-	-	-
V2-6HG8	.8	-.1	1	-	-	-1.2	40	300	40	-	-	-
	150	-100	140	-	-	-	-100	-100	-100	-	-	-
V3-6EW6	-.3	.8	-	-	300	150	0	-	-	-	-	-
	-.7	.6	-	-	300	170	0	-	-	-	-	-
V4-12BA6	-.3	0	-	-	300	150	1.5	-	-	-	-	-
	0	-	-	-	300	240	125	-	-	-	-	-
V5-6GX6	.1	4.5	#6.3	0	150	130	0	-	-	-	-	-
	-2.3	3.5	-	-	150	140	0	-	-	-	-	-
V6-6KE8	180	-.7	120	-	-	150	.8	5	0	-	-	-
	170	-.8	110	-	-	135	.8	5	0	-	-	-
V7-12AT7	-.1	0	30	-	-	-.1	0	30	0	-	-	-
	150	-3	2	-	-	150	0	2	-	-	-	-
V8-6EJ7	30	0	30	0	-	0	300	300	0	-	-	-
	3	-2	3	-	-	0	300	170	0	-	-	-
V9-6GK6	30	0	0	-	-	0	375	375	0	-	-	-
	6	-2.5	0	-	-	0	350	200	0	-	-	-
V10-6HF5	-	0	0	0	*-62	0	0	0	*-62	0	0	-
	-	0	75	.4	*-62	75	0	75	*-62	.4	75	-
V11-6HF5	-	0	0	0	*-62	0	0	0	*-62	0	0	-
	-	0	75	.4	*-62	75	0	75	*-62	.4	75	-
V12-OA2	0	0	0	0	0	0	0	-	-	-	-	-
	150	0	0	0	150	0	0	-	-	-	-	-

(010167)(031567)(101667)

Indicates this reading is taken on AC volts

* Indicates this reading varies with the bias setting potentiometer and must be properly set by the operator to be correct.

All readings taken with a VTVM; the unit tuned on 40 meters at 7.2 mHz as given in 4-2, through (b) only; RF gain maximum clockwise; PTT function.

The top line of readings for each tube are taken in RECEIVING, and the readings for each tube on the lower line are in TRANSMITTING (which is just closing the PTT circuit.)

6-2....

VOLTAGE CHART FOR TRANSISTORS

TRANSISTOR	EMITTER	BASE	COLLECTOR
Q1	15	15	11
Q2	4.4	3.8	15
Q3	.55	.6	11
Q4	3.3	3.8	15
Q5	11	15	16
Q6	16	11	10.8
Q7	10.8	10.6	0
Q8	-13.5	-13.4	-.3
Q9	1.7	2.4	8.8
Q10	11.7	12.2	25
Q11 (*)	-10.2	B2 element -3.7	B1 element -17
Q12	1.4	2	6
Q13	.13	.6	3
Q14	3.5	3	0
Q15	1.3	2	11
Q16	28.5	28.5	28

(*)Taken in transmit, the same as voltage readings.

All other readings taken in receive mode on 40 meters with RF gain clockwise and MIC gain counter-clockwise. Use a good VTVM (101667)

(010167)

6-3....

RESISTANCE READINGS

PIN	1	2	3	4	5	6	7	8	9	10	11	12
V1	3.3m	47	0	.6	60k	45k	0	-	-	-	-	-
V2	150	.1m	150	.6	.4	.1m	.11m	60k	.11m	-	-	-
V3	3.3m	47	.6	.4	55k	.1m	0	-	-	-	-	-
V4	3.3m	0	.4	0	60k	45k	100	-	-	-	-	-
V5	2.2m	1k	.4	0	.28m	.11m	22k	-	-	-	-	-
V6	65k	10k	.15m	.4	0	65k	100	470	100	-	-	-
V7	30k	.13m	inf.	.4	0	30k	0	inf.	4	-	-	-
V8	inf.	.33m	inf.	0	.4	0	60k	.1m	0	-	-	-
V9	inf.	22k	0	.4	.6	inf.	60k	.1m	0	-	-	-
V10	.6	inf.	30k	2.5	7.5	30k	inf.	30k	7.5	2.5	30k	0
V11	.6	inf.	30k	2.5	7.5	30k	inf.	30k	7.5	2.5	30k	0
V12	30k	0	inf.	0	30k	inf.	0	-	-	-	-	-

Resistances taken with power supply dis-connected, using a good VTVM.
 Controls left in settings specified for chart 6-2.
 All measurements made from point specified to chassis ground. The
 VOX and CALIBRATOR removed, and the VOX jumper strip installed.

(101667)

(010167)

6-4. . . . TOP CHASSIS VIEW

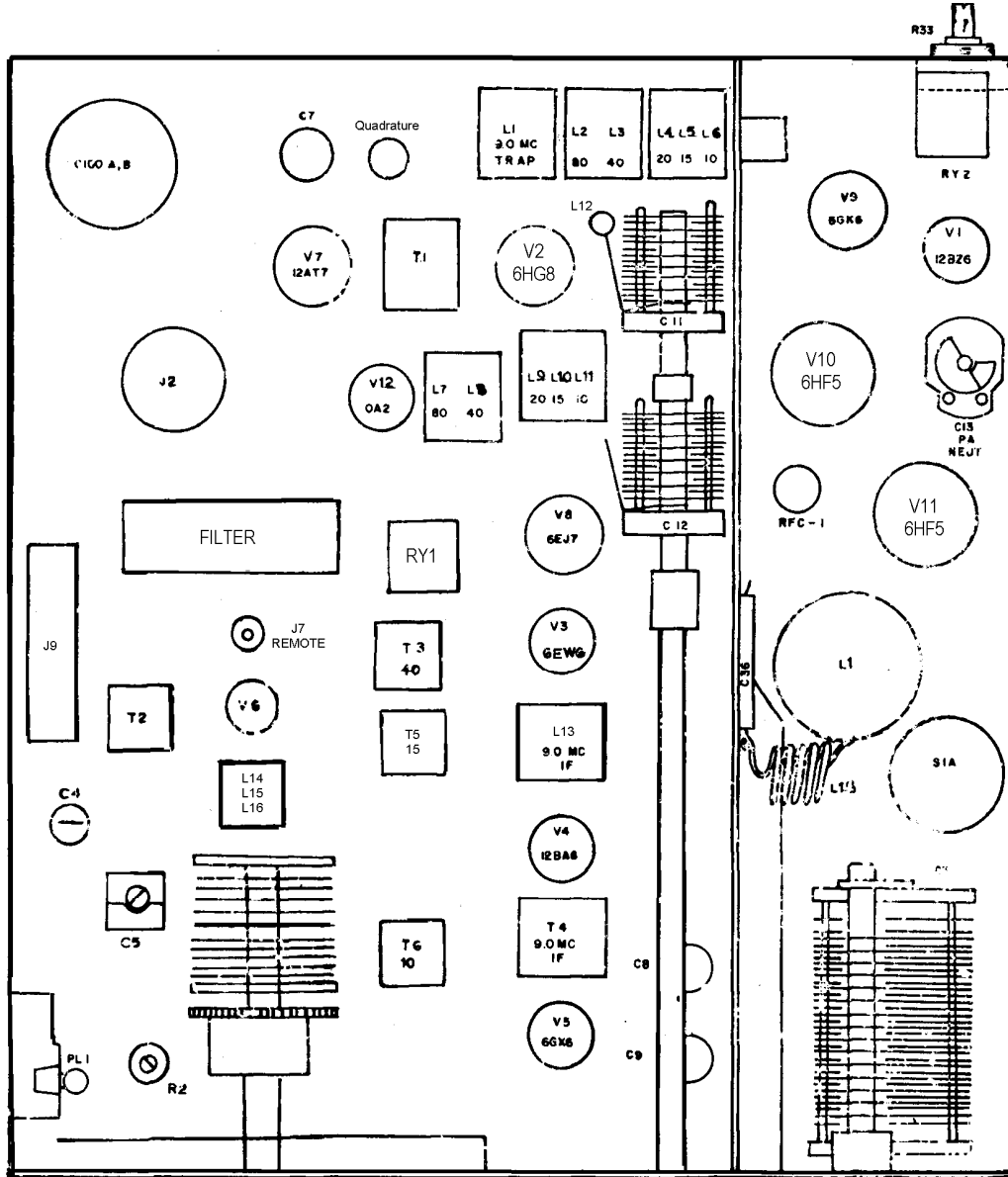

6-5. . . . CONVERTER ALIGNMENT IDENTIFICATION

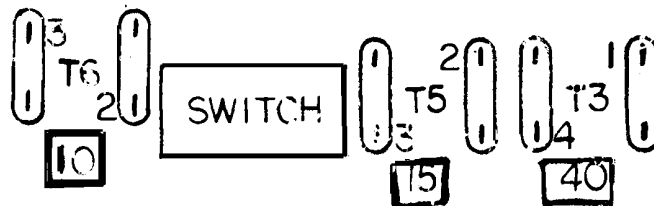

6-6. . . . ALIGNMENT INFORMATION

This is a complicated apparatus, and alignment should not be attempted without a full understanding of the circuitry and adequate test equipment.

DANGER !! HIGH VOLTAGE EXISTS AT EXPOSED COMPONENTS WHEN THIS UNIT IS OUT OF THE CABINET. USE EXTREME CAUTION, AS VOLTAGES ARE DANGEROUS TO LIFE!

TEST EQUIPMENT REQUIRED:

A signal generator with calibrated output level and frequency.

A 100 kHz calibrator.

A 50 Ohm , non-reactive dummy load rated at 200 watts.

An output indicator(Scope--R. F. voltmeter, etc.)

An accurate , low distortion audio generator.

An accurate VTVM.

6-7. . . . I. F. AMPLIFIER ALIGNMENT

1. . . . Remove the VOX or jumper board from the socket J9. This will prevent the unit from being placed in transmit accidentally.
2. . . . Set the controls as follows:
 - (a) R. F. gain fully clockwise.
 - (b) Function switch in PTT.
 - (c) LOAD control at a 10 o'clock position.
 - (d) PLATE control at a 12 o'clock position.
 - (e) BANDSWITCH to the 40 meter band(7. 0-7. 5 mHz).
3. . . . Connect the RF signal generator to the antenna jack.
4. . . . Set the Galaxy audio volume 1/2 open and allow 5 minutes to warm-up fully.
5. . . . Adjust the potentiometer R2 for zero "S" meter reading.
6. . . . Set the signal generator for 10, 000 μ v output at 9. 0 mHz. Vary the generator frequency slightly until a beat note tone is heard in the speaker. Adjust the PLATE tuning for maximum "S" meter reading. Adjust the generator output level until the "S" meter reads approximately S6.
7. . . . Adjust the slug in L13, and the slug in T1 for maximum "S" meter reading.
8. . . . Adjust the slug in L1(9 mHz trap) for minimum "S" meter reading.

6-8.... VFO ALIGNMENT

- 1.... Set the controls as follows:
 - (a) RF gain fully clockwise.
 - (b) FUNCTION switch to CAL. (If you do not have a calibrator, use an external source, but the accuracy of alignment depends on the accuracy of the reference.
 - (c) Set the BANDSWITCH to 80 meters. (3.5-4.0 MHz).
 - (d) Set EXCITER tuning to 10 o'clock position.
 - (e) Set SIDEBAND selector to SB1 position.
 - (f) Set hairline(plastic face over VFO dial) to center.
 - (g) Set VFO dial to 4.0 MHz. (500 on red scale).
- 2.... Adjust main tuning dial slightly to find 4.0 MHz signal.
- 3.... Adjust LI3 and main tuning dial until zero beat note and calibrator signal occur at 4.0 MHz. on the dial.
- 4.... Set the main tuning to 3.5 MHz. (0 on red scale).
- 5.... Adjust C5 and main tuning until zero beat note and calibrator signal occur at 3.5 MHz.
- 6.... Repeat steps 2 through 5 until tuning dial is at exactly 0 and 500 (red scale) to have zero beat note on 3.5 and 4.0 MHz, respectively.

6-9.... CONVERTER ALIGNMENT

- (a) Make a test fixture of a .001 mfd. ceramic capacitor connected in series with a 330 Ohm 1/2 watt resistor, with miniature clips on each end, as shown below.

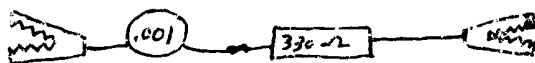

- (b) For location of alignment points refer to 6-5 drawing.
- (c) Turn the set off while connecting or dis-connecting the test fixture.
- (d) For alignment, do steps 1 through 11 using the information in the first set of bracketed figures (). Repeat the steps 1 through 11 using the figures in the second set of brackets. Repeat steps 1 through 11 using the information in the third set of bracketed figures.
 - 1.... Set BANDSWITCH to (7-7.5mHz)(21-21.5mHz)(28-28.5mHz)
 - 2.... Set VFO dial to (7.25 mHz)(21.250mHz)(28.5 mHz).
 - 3.... Set generator to(7.25mHz)(21.250mHz)(28.5 mHz).
 - 4.... Adjust the following for maximum "S" meter readings:

- 5.... Coil (L14 top slug)(L15 middle slug)(L16 bottom slug)
- 6.... Connect the test fixture from chassis ground to the lug mentioned in each step.
- 7.... Remember to turn off the set each time you change the test fixture.
- 8.... Adjust the bottom slug of (T3, load lug 4)(T5, load lug 3) (T6, load lug 3)
- 9.... Repeat steps 6 & 7 for the following adjustments:
- 10... Adjust the top slug of (T3, load lug 1)(T5, load lug 2) (T6, load lug 2)
- 11... Repeat steps 6 through 10 again for more exact alignment.

6-10.... EXCITER ALIGNMENT

- (a) Attach a suitable dummy load to the antenna jack, and also a suitable RF output indicator device across the load.
- (b) Replace the VOX or VOX jumper board.

80 METERS - BANDSWITCH to 3.5-4.0 MHz.
 SIDEBAND switch to SB2.
 PLATE tuning to 2 o'clock position.
 LOAD control to 10 o'clock position.
 MIC gain maximum counter-clockwise.
 VFO dial to 4.0 MHz. (500 on red scale).
 EXCITER control to 9 o'clock position.
 FUNCTION switch to TUNE.
 Advance MIC gain until meter rises to "S"5.
 Adjust L2 and L7 (bottom slugs) for maximum meter reading, using the MIC control to keep the reading under "S"5.
 Return FUNCTION switch to PTT.

40 METERS - BANDSWITCH to 7.0-7.5 MHz.
 PLATE tuning to 12 o'clock.
 LOAD control to 10 o'clock.
 MIC gain maximum counter-clockwise.
 VFO dial to 7.5 MHz. (500 red scale).
 EXCITER tuning to 9 o'clock.
 FUNCTION switch to TUNE.
 Advance MIC gain until meter rises to "S"5.
 Adjust L3 and L8 (top slugs) for maximum meter reading, keeping meter below "S"5 with MIC control.
 Return FUNCTION switch to PTT.

- 10 METERS - BANDSWITCH to 28.0-28.5 mHz.
 PLATE control to 10 o'clock.
 LOAD control to 11 o'clock.
 MIC gain maximum counter-clockwise.
 VFO dial to 28.0 mHz.
 EXCITER tuning to 3 o'clock.
 FUNCTION switch to TUNE.
 Advance MIC gain until meter rises to "S"5.
 Adjust L6 and L11(bottom slugs) for maximum meter reading, keeping meter below "S"5 with MIC control.
 Return FUNCTION switch to PTT.
- 15 METERS - BANDSWITCH to 21.0-21.5 mH
 PLATE tuning to 10 o'clock.
 LOAD control to 11 o'clock.
 MIC gain maximum counter-clockwise.
 VFO dial to 21.0 mHz. (0 on red scale).
 EXCITER tuning to 3 o'clock.
 FUNCTION switch to TUNE.
 Advance MIC gain until meter rises to "S"5.
 Adjust L5 and L10(middle slugs) for maximum meter reading, keeping meter below "S"5 with MIC control.
 Return FUNCTION switch to PTT.
- 20 METERS - BANDSWITCH to 14.0-14.5 mHz.
 PLATE tuning to 11 o'clock.
 LCAD control to 11 o'clock.
 MIC gain maximum counter-clockwise.
 VFO dial to 14.0 mHz. (0 on blue scale).
 EXCITER tuning to 3 o'clock.
 FUNCTION switch to TUNE.
 Advance MIC gain until meter rises to "S"5.
 Adjust L4 and L9 (top slugs) for maximum meter reading, keeping meter below "S"5 with MIC control.
 Return FUNCTION switch to PTT position.

6-11.... CARRIER SUPPRESSION ADJUSTMENT

- 1... Attach an RF output indicator and dummy load.
- 2... Set BANDSWITCH 7.0-7.5 mHz. Set VFO anywhere.
- 3... Tune-up transmitter normally(4-2 completely), then place FUNCTION switch to PTT and MIC gain max. counter-clockwise.
- 4... Close microphone PTT switch.
- 5... Adjust output indicator for good indication.
- 6... Observe power output level on indicator used.
- 7... Adjust C7 and R1 for minimum power output. These two adjustments interact and should be repeated several times.
- 8... Set SIDEBAND selector switch to opposite side and observe

carrier remaining, if any. If any remains, C7 and R1 may have to be re-set for a compromise to obtain best suppression on both sidebands.

6-12.... CARRIER CRYSTAL ALIGNMENT

- 1... Set-up the same as 6-11, steps 1-2-3, then select SB1.
- 2... Connect an accurately calibrated audio signal generator to the microphone jack. Also, connect a SPST toggle switch to the PTT circuit. (Front or rear jacks).
- 3... Set the audio generator to 1000 Hz with .02 volts output.
- 4... Close the PTT circuit with the toggle switch and adjust the MIC gain for a meter reading of about "S" 9.
- 5... Observe the exact reading of the output indicator used.
- 6... Change the audio generator to exactly 350 Hz and, if necessary, adjust C9 until the output indicator shows exactly 1/2 the reading it did before. Open the PTT.
- 7... Switch to SB2, then repeat step 3 and 4 and 5.
- 8... Change the generator to exactly 350 Hz and, if necessary, adjust C8 until the output indicator shows exactly 1/2 the output it did before.
- 9... Open the PTT. Dis-connect the generator and PTT toggle. Connect the microphone as usually done.
- 10... Repeat the carrier adjustment, section 6-11 completely.

6-13.... FINAL AMPLIFIER NEUTRALIZATION

- 1... Set the BANDSWITCH to the 28.0-28.5 mHz range. Set the VFO dial to 28.5 mHz (500 red scale).
- 2... Do a normal tune-up as given in section 4-2, then set the FUNCTION switch to CW and close the PTT circuit.
- 3... Rock the PLATE tuning slightly to either side and observe if the maximum power output on the indicator occurs exactly at the "dip", or minimum plate current on the meter. If this does not occur, adjust C13 slightly until the "dip" and maximum power output occur together.
- 4... Open the PTT circuit and set the FUNCTION switch to PTT position.

6-14.... VFO SIDEBAND SHIFT ADJUSTMENT

- 1... BANDSWITCH to 3.5-4.0 mHz.
- 2... VFO to 3.8 mHz.
- 3... RF gain maximum clockwise.
- 4... Audio level and other functions for receiving on SB1
- 5... Turn on the CAL position, or inject an external source of strong, unmodulated, stable signal for exact zero beat.
- 6... Switch to SB2 and adjust C4 for exact zero beat again.

ALIGNMENT COMPLETE

SECTION VII

7-1.... SERVICE INFORMATION

The following information **MUST** be given in correspondence if we are to provide the best possible service. Omission of the required information may cause delay.

When writing, address correspondence to:

GALAXY ELECTRONICS
Service Department
10 South 34th St.
Council Bluffs, Iowa -51501

At the heading of your letter please give the following:

- (a) MODEL of equipment in your report.
- (b) SERIAL of equipment in your report.
- (c) DATE of purchase.
- (d) DEALERS name and city.

When describing parts in the equipment refer to the schematic number, if given; otherwise the most concise description possible.

7-2. . . . INFORMATION ONLY

If you have a problem, or just a question about your equipment, we'll be glad to answer it as well as possible. State the nature of the inquiry--describe parts, etc. by schematic numbers--any measurements or effects observed.

7-3. . . . ORDERING PARTS - IN WARRANTY

It is most important that the required information of 7-1 be listed, and that we have your warranty card on file. For this reason you should send the warranty card in immediately when the purchase is made. If we do not have this on file there might be delay in validating a warranty before any adjustment can be made.

In most cases we can supply a part in warranty on an "exchange later" basis. When we know exactly what you require we can usually ship the replacement part with a return label for the defective part. It is important that any such defective part then be returned immediately to us, prepaid, to maintain the warranty.

PLEASE READ OUR WARRANTY so that you will be familiar with the terms.

7-4. . . . ORDERING PARTS - NOT IN WARRANTY

In the event you know exactly what parts you need, they may be ordered direct from us to expedite. However, WE DO NOT OFFER A BILLING SERVICE, and all shipments are on a cash basis. You may send your check with the order, or we can ship most parts C. O. D. The easiest method of handling is to send a check signed but without the amount filled in. IF YOU MAKE IT PAYABLE TO GALAXY ELECTRONICS we will assume responsibility that it will only be made out for the exact cost of the parts ordered and shipping costs to you. Under no circumstances send it signed without showing us as payee, or then it could be cashed by anyone and we could not accept responsibility. In this way you avoid C. O. D. costs .

7-5. . . . RETURNING EQUIPMENT FOR SERVICE

PLEASE do not ship equipment to us without prior arrangements. We prefer to send special shipping labels, and this will often avoid delay of unexpected shipments.

If time is extremely important, it is best to wire or call for approval and we will rush shipping labels. When a shipment is expected, even the time of sending you labels is less than that lost, usually, when an unexpected shipment is received.

It is VERY IMPORTANT that the shipment be well packed and fully insured. Damage claims must be settled between you and the carrier and will greatly delay any returns. Proper packing normally avoids this trouble.

SEND ALL SHIPMENTS TO US PREPAID.

(All returns will be made in our standard cartons only.)

When shipments are returned it may be handled in three ways: Where all service is in warranty the shipment will be returned with transportation costs collected by the carrier on arrival. If there are any charges not covered by warranty we can hold the shipment and advise you of costs, which you can then send and shipment will arrive with only transportation costs collected by the carrier on arrival. Or if there are charges not covered by warranty you may send a blank check payable to us, which we will make out for the charges of our service and you pay transportation cost on arrival. Or we will ship C. O. D. for any charges not covered by warranty, then the carrier will collect these charges and transportation costs on arrival.

NOTE!!! We will NOT ship by means of a carrier that will not fully insure the shipment. Some carriers have a \$200.00 limit, and this will not cover the value of a transceiver or similar major item. The exception to this is when there is no other means (APO-FPO, etc.), of shipment than parcel post, and then we will ship by this means with your written agreement that you assume any loss over that which the carrier will insure.

(C. O. D. shipments can not be made to APO-FPO)

We prefer to ship R. E. A. Express, AIR EXPRESS, or AIR FREIGHT.

8-1....

WARRANTY POLICY

Galaxy Electronics, Inc. guarantees to remedy any defect in material or workmanship existing in a V MK2 transceiver at no cost to the owner, exclusive of shipping charges, provided: That the defect is not caused by improper installation or use contrary to our instructions; that the unit serial has been registered with us by the original purchaser; that the equipment or part that appears defective is delivered to us or the authorized repair station we may designate for examination; and that examination does, in our judgement, disclose a defective part or workmanship.

This warranty applies to labor, tubes and semi-conductors for a period of 90 days, and for other parts for a period of one year from the date of purchase by the original owner.

The warranty applies to only the original purchaser and is not transferable.

This warranty does not cover any transportation costs that may be incurred, and our sole liability is repair of any defect, for the period stated.

No person is authorized to assume for us any other liability in connection with the sale of this or other of our products.

Galaxy Electronics, Inc. reserves the right to make any changes deemed necessary or desirable by us to improve the product, without advance notice, or incurring any obligation to make like changes or improvements in units previously manufactured or sold.

All warranties expressed here are void and terminated one year after the last V MK2 has been manufactured by us.

PARTS LISTING

All parts shown are subject to change of specifications or price without advance notice. Prices shown are for a single part, and shipping costs are additional.

9-1....

RESISTORS

All resistors are 1/2 watt, 10%, unless noted.

SYMBOL	DESCRIPTION	GALAXY-#	PRICE EA.
R1	2.5k pot	13-07	\$ 1.43
R2	50k pot	13-08	1.70
R3	3.5k 10W	11-1D	.45
R4	4.7k 1W	10-35A	.25
R5	2.2k	10-31	.20
R6	27k 1W	10-49A	.25
R7	33k 2W 5%	10-71B	.55
R8	100 1W	10-65A	.25
R9	10 1W 5%	10-71A	.30
R10	10 1W 5%	10-71A	.30
R11	10 1W 5%	10-71A	.30
R12	10 1W 5%	10-71A	.30
R13	100 1W	10-65A	.25
R14	1.2k 5%	10-78	.25
R15	68k 1W	10-68A	.25
R16	47k 2W	10-52B	.30
R17	100 1W	10-65A	.25
R18	22k	10-06	.20
R19	10k	10-56	.20
R20	10k	10-56	.20
R21	10k	10-56	.20
R22	100k	10-32	.20
R23	6.8k	10-15	.20
R24	270	10-68	.20
R25	39k 2W	10-68B	.30
R26	270k	10-12	.20
R27	1.5k 1W	10-21A	.25
R28	6.8k	10-15	.20
R29	1k	10-42	.20
R30	1k	10-42	.20
R31	6.8k	10-15	.20

SECTION IX

GALAXY V MK2

SYMBOL	DESCRIPTION	GALAXY #	PRICE EA.
R32	100 , 5%	10-19	\$.30
R33	7.5k pot	13-12	1.05
R34	1.5k , 5%	10-20	.30
R35	6.8k	10-21	.30
R36	470	10-53	.20
R37	100k	10-32	.20
R38	1.8k	10-17	.20
R39	6.8k	10-15	.20
R40	33k	10-65	.20
R41	330	10-28	.20
R42	330	10-28	.20
R43	5.6k	10-83	.20
R44	1k	10-42	.20
R45	2.2k	10-31	.20
R46	33k	10-65	.20
R47	12k	10-84	.20
R48	10k 3W	11-1B	1.85
R49	470	10-53	.20
R50	100	10-07	.20
R51	22k 2W	10-41B	.30
R52	10k	10-56	.20
R53	100	10-7	.20
R54	100k	10-32	.20
R55	4.7k	10-36	.20
R56	470	10-53	.20
R57	47	10-29	.20
R58	330	10-28	.20
R59	1.5k	10-03	.20
R60	2.2k	10-31	.20
R61	1.2k	10-73	.20
R62	10k pot(incl. R110)	13-31	2.10
R63	330k	10-69	.20
R64	330k	10-69	.20
R65	10k	10-56	.20
R66	800 10W	11-3D	.45
R67	10k P. C. B. pot	13-23	.77
R68	47k	10-13	.20
R69	68k	10-33	.20
R70	100k	10-32	.20
R71	68k 2W	10-63B	.30

(010167)
(092667)

(101667)

PAGE 34

SECTION IX

GALAXY V MK2

SYMBOL	DESCRIPTION	GALAXY #	PRICE EA.
R72	1k	10-42	. 20
R73	2. 2m	10-02	. 20
R74	220k	10-04	. 20
R75	47k 1W	10-46A	. 20
R76	47k	10-13	. 20
R77	1m	10-10	. 20
R78	1k	10-42	. 20
R79	100	10-07	. 20
R80	100k	10-32	. 20
R81	1k	10-42	. 20
R82	47k	10-13	. 20
R83	47	10-29	. 20
R84	220	10-58	. 20
R85	100k	10-32	. 20
R86	47k 2W	10-52B	. 30
R87	27k 2W	10-60B	. 30
R88	150	10-43	. 20
R89	100k	10-32	. 20
R90	220 1W	10-67A	. 25
R91	6. 8k	10-15	. 20
R92	100k	10-32	. 20
R93	10k	10-56	. 20
R94	10k	10-56	. 20
R95	47	10-29	. 20
R96	47k	10-13	. 20
R97	3. 3m	10-57	. 20
R98	220k	10-04	. 20
R99	15k 1W	10-20A	. 25
R100	1. 5k	10-03	. 20
R101	47	10-29	. 20
R102	10k	10-56	. 20
R103	10k	10-56	. 20
R104	220k	10-04	. 20
R105	1. 5k	10-03	. 20
R106	270k	10-12	. 20
R107	1. 5m	10-89	. 20
R108	1. 5m	10-89	. 20
R109	10k	10-56	. 20
R110	100k(part of R62)		see R62
R111	10k	10-56	. 20
R112	270k	10-12	. 20

SYMBOL	DESCRIPTION	GALAXY #	PRICE EA.
R113	3.3k	10-59	.20
R114	560	10-67	.20
R115	10k	10-56	.20
R116	100k	10-32	.20
R117	1.5k	10-03	.20
R118	1.5k	10-03	.20
R119	1k	10-42	.20
R120	15k	10-81	.20
R121	10k	10-56	.20
R122	10k pot(incl. R127/S4)	13-18	2.83
R123	1k	10-42	.20
R124	47k	10-13	.20
R125	33k	10-65	.20
R126	4.7m	10-70	.20
R127	50k pot(incl. R122/S4)		see R122
R128	560k	10-91	.20
R129	1.5k	10-03	.20
R130	10k	10-56	.20
R131	15k	10-81	.20
R132	39k	10-92	.20
R133	1.5k	10-03	.20
R134	1k	10-42	.20
R135	2.7k	10-66	.20
R136	82	10-87	.20
R137	1 1W	10-91A	.25
R138	1 1W	10-91A	.25
R139	1k	10-42	.20
R140	100	10-07	.20
R141	15k	10-81	.20
R142	100k	10-32	.20
R143	470k	10-11	.20
R144	not used		
R145	47	10-29	.20
R146	10 1W 5%	10-71A	.30
R147	47	10-29	.20
R148	Thermistor, spec.	210-3	.90

9-2. . . . CAPACITORS

All capacitors are ceramic at 600VDC rating, unless otherwise noted. Those marked DSM are dipped silver mica at 500VDC rating. Those marked NPO, N750, TC are temperature compensating types at 500VDC. The variable types are normally special and field replacement is not normally practical and replacements should be obtained from us. All types that are over 1 mfd are electrolytic capacitors. All decimal listings are in mfd. Others are mmfd. unless noted otherwise.

SYMBOL	DESCRIPTION	GALAXY #	PRICE EA.
C1	.001	20-24	\$.15
C2	.01	20-05	.15
C3	plate tuning	25-15	2.58
C4	5/25 trimmer	26-06	1.35
C5	13 vfo tracking	25-24	2.65
C6	33 DSM	22-07	.30
C7	5/25 trimmer	26-06	1.35
C8	5/25 trimmer	26-06	1.35
C9	5/25 trimmer	26-06	1.35
C10	10 1kv	20-27	1.78
C11	variable	25-21A	4.76
C12	variable	25-21B	4.50
C13	variable	25-11A	2.80
C14A/B/C	LOAD variable	25-10	4.37
C15	.005	20-03	.15
C16	.01 1.6kv	20-29	.35
C17	.01	20-05	.15
C18	.1 200VDC paper	23-07	.46
C19	.005	20-03	.15
C20	.001	20-24	.15
C21	.001	20-24	.15
C22	.001	20-24	.15
C23	.001	20-24	.15
C24	.001	20-24	.15
C25	.001	20-24	.15
C26	.001	20-24	.15
C27	.001	20-24	.15
C28	.001	20-24	.15

SECTION IX

GALAXY V MK2

SYMBOL	DESCRIPTION	GALAXY #	PRICE EA.
C29	.001	20-24	\$.15
C30	.001	20-24	.15
C31	.001	20-24	.15
C32	.005	20-03	.15
C33	100 DSM	22-21	.30
C34	33 DSM	22-07	.30
C35	18 DSM	22-24	.30
C36	.001 5Kv mica	22-18	4.25
C37	.005	20-03	.15
C38	10 1Kv	20-27	.30
C39	.005	20-03	.15
C40	.005	20-03	.15
C41	18 DSM	22-24	.30
C42	33 DSM	22-07	.30
C43	100 DSM	22-21	.35
C44	.001	20-24	.15
C45	47 DSM	22-30	.35
C46	.002 DSM	22-27	.90
C47	.01	20-05	.15
C48	25	20-08	.15
C49	.005	20-03	.15
C50	.005	20-03	.15
C51	.01	20-05	.15
C52	100 DSM	22-21	.35
C53	560 DSM	22-36	.40
C54	150 DSM	22-26	.35
C55	.01	20-05	.15
C56	.01	20-05	.15
C57	.001 1Kv	20-24	.15
C58	.01	20-05	.15
C59	.01	20-05	.15
C60	.001 1Kv	20-24	.15
C61	.001 DSM	22-19	.67
C62	.001 DSM	22-19	.67
C63	.01	20-05	.15
C64	.001 DSM	22-19	.67
C65	.1 50v	20-33	.75
C66	6.8(approx) TC	selected	.75
C67	68 NPO	20-67	.30
C68	15 N750	20-65	.45
C69	variable	25-17A	3.30
C70	330 N750	20-66	.91

SECTION IX

GALAXY V MK2

SYMBOL	DESCRIPTION	GALAXY #	PRICE EA.
C71	6.8 NPO	20-64	.75
C72	100	20-23	.20
C73	.001	20-24	.15
C74	.001	20-24	.15
C75	.001	20-24	.15
C76	82 DSM	22-48	.30
C77	20 DSM	22-22	.30
C78	150 DSM	22-26	.30
C79	.01	20-05	.15
C80	.01	20-05	.15
C81	.01	20-05	.15
C82	100 mfd	29-09	1.44
C83	100 DSM	22-21	.30
C84	.001	20-24	.15
C85	.01	20-05	.15
C86	.001	2--24	.15
C87	10 DSM	22-37	.30
C88	50 DSM	22-11	.30
C89	470	20-39	.30
C90	.001	20-24	.15
C91	50 DSM	22-11	.30
C92	50 DSM	22-11	.30
C93	.01	20-05	.15
C94	.01	20-05	.15
C95	.005	20-03	.15
C96	.001	20-24	.15
C97	470	20-39	.20
C98	.001	20-24	.15
C99	.01	20-05	.15
C100A/B	2X 40 @450VDC	24-21	2.69
C101	.005	20-03	.15
C102	4.7 1Kv	20-53	.25
C103	39 DSM	22-08	.30
C104	.01	20-05	.15
C105	100	20-23	.20
C106	.01	20-05	.15
C107	220 DSM 5%	22-23	.38
C108	50 DSM	22-11	.30
C109	.001	20-24	.15
C110	.005	20-03	.15

SECTION IX

GALAXY V MK2

SYMBOL	DESCRIPTION	GALAXY #	PRICE EA.
C111	.001	20-24	.15
C112	.001	20-24	.15
C113	.01	20-05	.15
C114	.001 mica feedthrough	22-28	4.88
C115	.01	20-05	.15
C116	.001	20-24	.15
C117	.47 100v	23-18	.85
C118	.1 50v	20-38	.75
C119	.01	20-05	.15
C120	.01	20-05	.15
C121	.1 50v	20-38	.75
C122	470	20-39	.20
C123	.01	20-05	.15
C124	2 mfd 50v	29-12	.89
C125	.05 50v	20-57	.35
C126	.01	20-05	.15
C127	.01	20-05	.15
C128	.1 50v	20-38	.75
C129	.01	20-05	.15
C130	.001	20-24	.15
C131	.001	20-24	.15
C132	500 1Kv 10%	20-37	.30
C133	43 DSM	22-29	.30
C134	500 1Kv 10%	20-37	.30
C135	62 DSM	22-09	.30
C136	.005	20-03	.15
C137	.1 50v	20-38	.75
C138	.02 50v	20-39	.30
C139	.22 100v	23-17	.60
C140	.01	20-05	.15
C141	.01	20-05	.15
C142	10 mfd 15v	29-14	.75
C143	100 mfd 15v	29-13	1.60
C144	.01	20-05	.15
C145	.22 100v	23-15	1.00
C146	.01	20-05	.15
C147	.01	20-05	.15
C148	.01	20-05	.15
C149	.01	20-05	.15
C150	.01	20-05	.15

SECTION IX

GALAXY V MK2

SYMBOL	DESCRIPTION	GALAXY #	PRICE EA.
C151	.01	20-05	.15
C 52	.01	20-05	.15
C153	.01	20-05	.15
C154	.01	20-05	.15
C155	.01	20-05	.15
C156	.01	20-05	.15
C157	.01	20-05	.15
C158	.005	20-03	.15
C159	100 mfd 15v	29-09	1.45
C160	.01	20-05	.15
C161	180 DSM	22-52	.30



We recommend that the 6HF5 tubes used in this equipment be ordered from Galaxy in-- pairs only. Use only GE brand 6HF5 tubes.

V1	12BZ6	110-12BZ6	2.10
V2	6HG8	110-6HG8	4.10
V3	6EW6	110-6EW6	2.35
V4	12BA6	110-12BA6	1.60
V5	6GX6	110-6GX6	2.60
V6	6KE8	110-6KE8	5.35
V7	12AT7	110-12AT7	2.85
V8	6EJ7	110-6EJ7	3.55
V9	6GK6	110-6GK6	3.00
V10	6HF5 (GE only)	110-6HF5	4.38
V11	6HF5 (GE only)	110-6HF5	4.38
V12	OA2	110-OA2	1.85

NE1	LSB light	113-B9NE2EAL	.95
NE2	USB light	113-B9NE2UAL	.95

	D1	1N34A	112-1N34A	.90
	D2	1N4738 (8.2v zener)	112-1N4738	4.75
	D3	501 (750 ma. 400piv)	112-501	.75
	D4	2N2926(o)	111-6(o)	.80
(010167)	D5	501(750 ma. 400 piv)	112-501	.75
(020267)	D6	1N34A	112-1N34A	.90
(031567)	D7	1N462	112-1N462	.85
(092667)	D8	1N462	112-1N462	.85
	D9 /10	2N2926(a)	111-6(a)	.80
	D11	501(750 ma. , 400piv)	112-501	.75

SECTION IX

GALAXY V MK2

SYMBOL	DESCRIPTION	GALAXY #	PRICE EA.
S1a	P. A. bandswitch	53-19	3.00
S1b	Converter bandswitch	53-29	2.85
S1c	Main bandswitch	53-18	2.24
S2	SB selector	53-13	1.78
S3	Function	53-28	4.85
S4	part of assembly		See R122
J1	Octal socket	61-07	.60
J2	Octal socket	61-07	.60
J3	Key jack	102-01	.85
J4/5/6	Triple phono jack	100-05	.35
J7	Phono jack	100-04	.10
J8	Microphone jack	103-03	1.30
J9	VOX socket	61-17	3.80
J10	Phono jack	100-04	.10
J11	SO-239 coax jack	101-01	1.15
J12	Phono jack	100-04	.10
J13/14/15	Triple phono jack	100-05	.35
X1	21.5 mHz crystal	117-06	5.80
X2	35.5 mHz crystal	117-07	5.88
X3	42.5 mHz crystal	117-08	6.00
X4	43.0 mHz crystal	117-09	6.00
X5	LF carrier xtal	117-21A	5.44
X6	HF carrier xtal	117-21B	5.44
F1	2.1 kHz filter	117-21	46.50
K1	Relay, 4PDT, 12VDC	116-15	8.88
K2	Relay, 3PDT, 12VDC	116-14	7.20
T1	9 mHz bal. mod.	73-08	1.73
T2	VFO output	76-10	3.02
T3	16-16.5 mHz	76-05	1.82
T4	9 mHz	73-06	1.48
T5	30-30.5 mHz	76-03	1.68
T6	37-38.5 mHz	76-04	1.68

	SYMBOL	DESCRIPTION	GALAXY #	PRICE EA.
	L1	9 mHz trap	42-36	2.37
	L2	80-40 coil	42-34	2.14
	L3	80-40 coil	42-34	2.14
	L4	20-10 coil	42-33	2.52
	L5	20-10 coil	42-33	2.52
	L6	20-10 coil	42-33	2.52
	L7	80-40 coil	42-31	2.22
	L8	80-40 coil	42-31	2.22
	L9	20-10 coil	42-32	2.52
	L10	20-10 coil	42-32	2.52
	L11	20-10 coil	42-32	2.52
	L12	40 trap coil	42-37	1.52
	L13	9 mHz coil	42-27	1.52
	L14	40-15-10 coil	42-35	2.13
	L15	40-15-10 coil	42-35	2.13
	L16	40-15-10 coil	42-35	2.13
	L17	80-15 coil	42-25B	5.75
	L18	10 coil	40-13	1.85
	RFC1	plate choke	30-13	1.60
	RFC2	750 uh	30-03	.70
	RFC3	750 uh	30-03	.70
	RFC4	2.5 mh	30-09	.70
	RFC5	750 uh	30-03	.70
	RFC6	.33 uh	30-24	.80
	RFC7	.56 uh	30-23	.80
	RFC8	2.2 mh(4425-10k)	30-22	.55
	RFC9	39 uh	30-21	.95
	RFC10	750 uh	30-03	.70
	RFC11	39 uh	30-21	.95
	RFC12	.56 uh	30-23	.80
	Q1	2N4354	111-16	2.85
	Q2	2N2926(o)	111-6o	.80
	Q3	2N3563	111-15	1.75
	Q4	2N2926(y)	111-6y	.80
	Q5	2N3638	111-10	1.40
	Q6	2N4107 Matched		
	Q7	Pair	111-18	4.75
	Q8	2N2926(g)	111-6g	.80
	Q9	2N2926(o)	111-6o	.80
	Q10	2N2926(o)	111-6o	.80
	Q11	2N2646	111-07	3.00
(010167)	Q12	2N3563	111-15	1.75
(031567)	Q13	2N2926(y)	111-6y	.80
(082867)	Q14	2N3638	111-10	1.40
(092667)	Q15	2N3563	111-15	1.75
	Q16	2N2926(g)	111-6g	.80

SECTION IX

GALAXY V MK2

SYMBOL	DESCRIPTION	GALAXY #	PRICE EA.
-	VOX jumper strip	200-4	1.00
P2	Octal jumper plug	109-1	.58
P1	Power plug	104-5	1.25
M1	Panel meter	115-6	15.54
-	Knob, large fixed	130-14-1A	1.00
-	Slider for above	130-14-8	.60
-	Knob, calibrated	130-14-2A	1.00
-	Knob, slow tune	130-14-3	.85
-	Knob, RF gain	130-14-4	.37
-	Knob, Audio gain	130-14-5	.77
-	Knob, bandswitch	130-14-7	.77
-	Knob, all other	130-14-6	.77
-	Esc. for VFO dial	134-4	.35
-	Cabinet	140-22	15.80
-	Front panel	141-24	6.04
-	Rear panel	142-28	5.24
-	Vernier drive	172-11A	2.00
-	Calibrated VFO dial	172-29	3.65
-	Plastic window	172-30	2.50
-	Packing carton	182-14	3.30
-	Front foot	133-31/32	.35
-	Rear foot	133-31	.20

GALAXY V MK2
SCHEMATIC

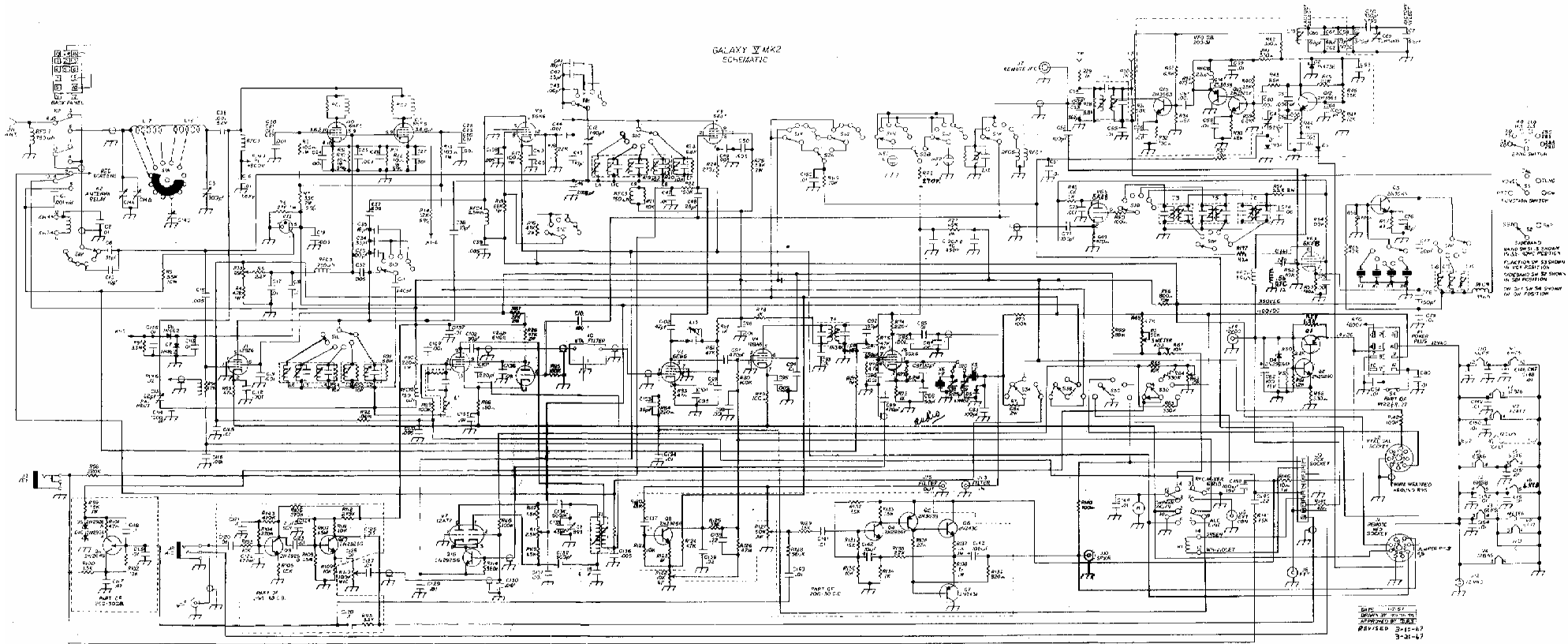

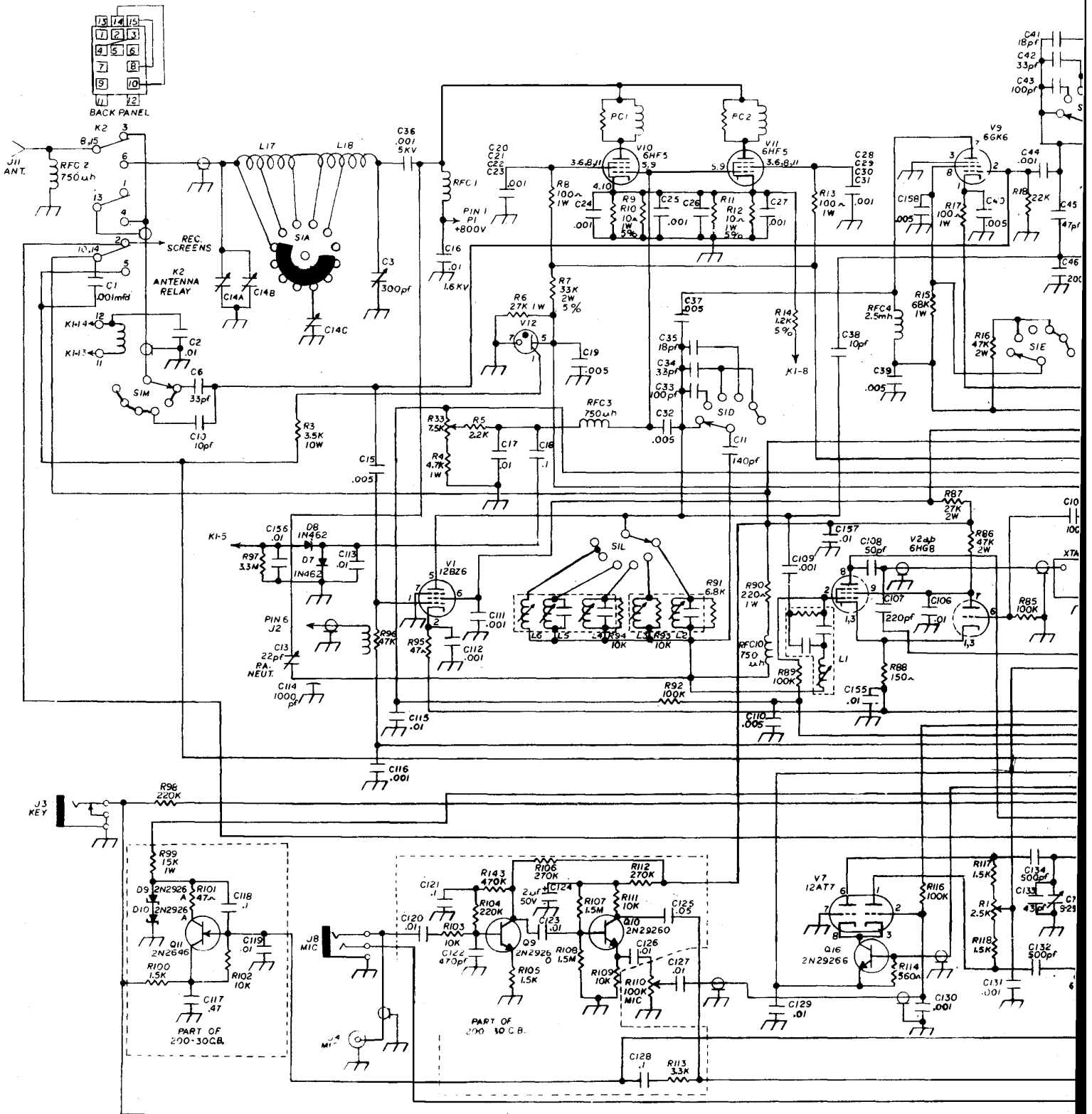

GALAXY V MK2
SCHEMATIC

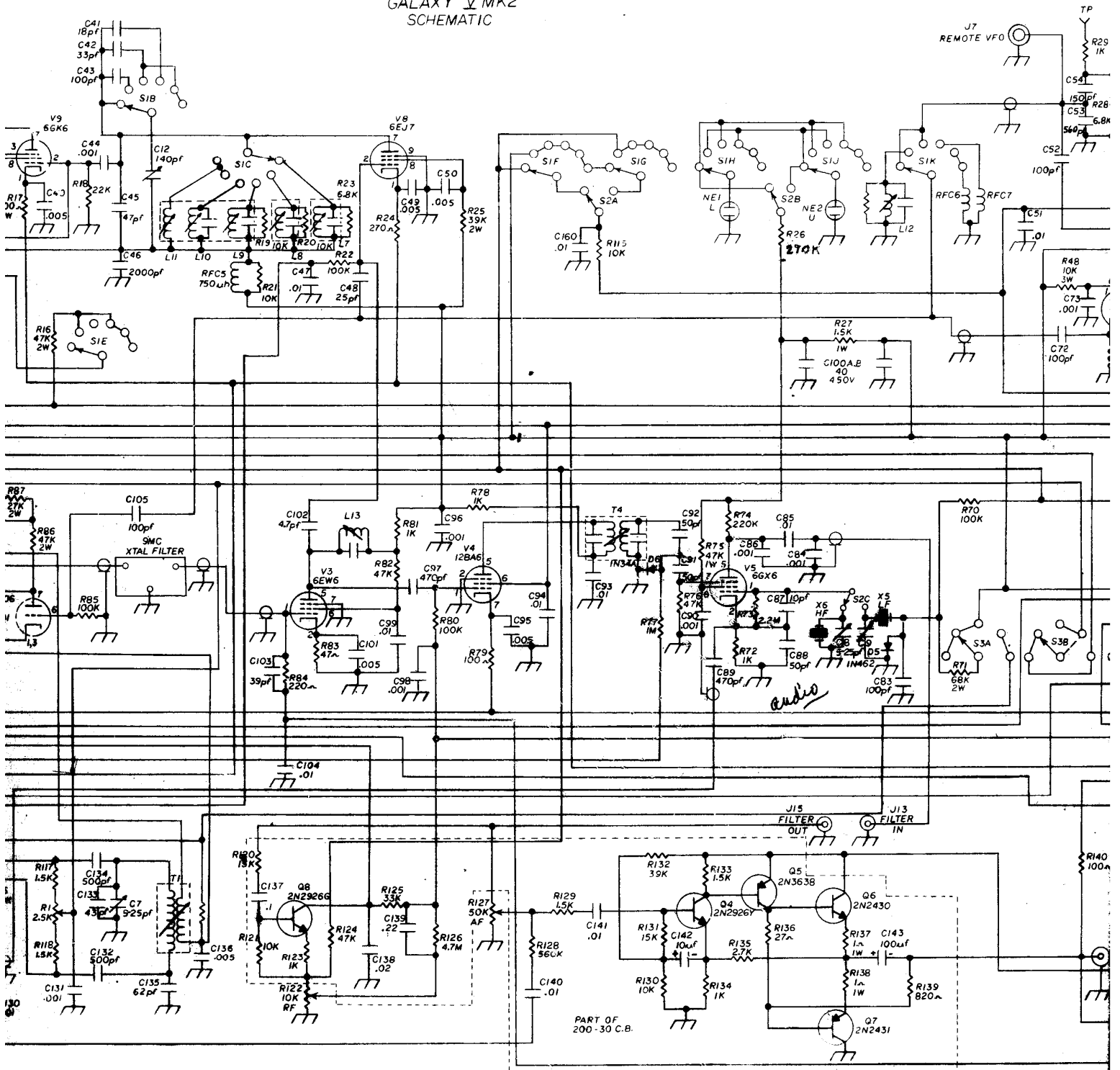

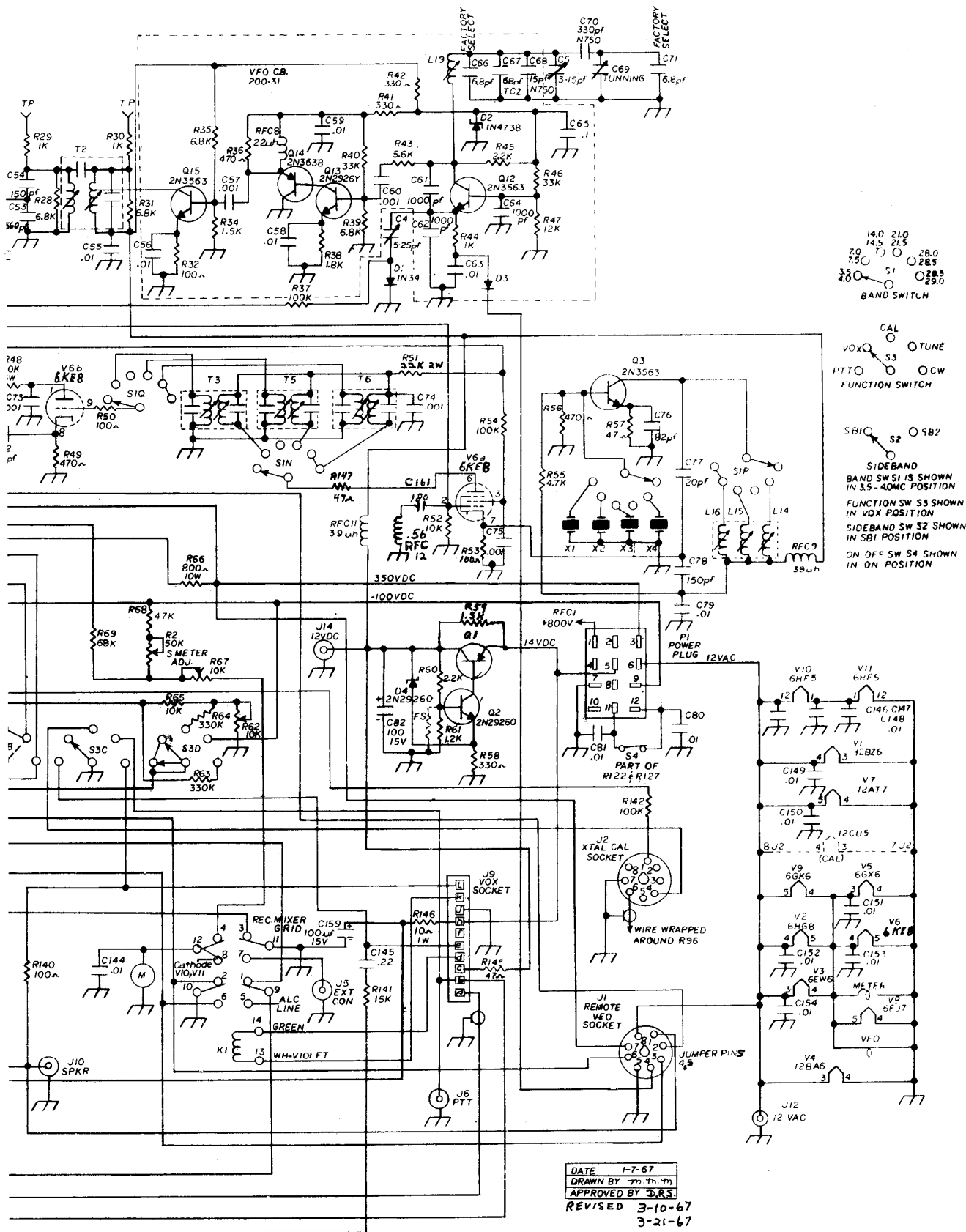

DATE 1-7-67
 DRAWN BY T. T. T.
 APPROVED BY D. R. S.
 REVISED 3-10-67
 3-21-67