

* instruction * manual

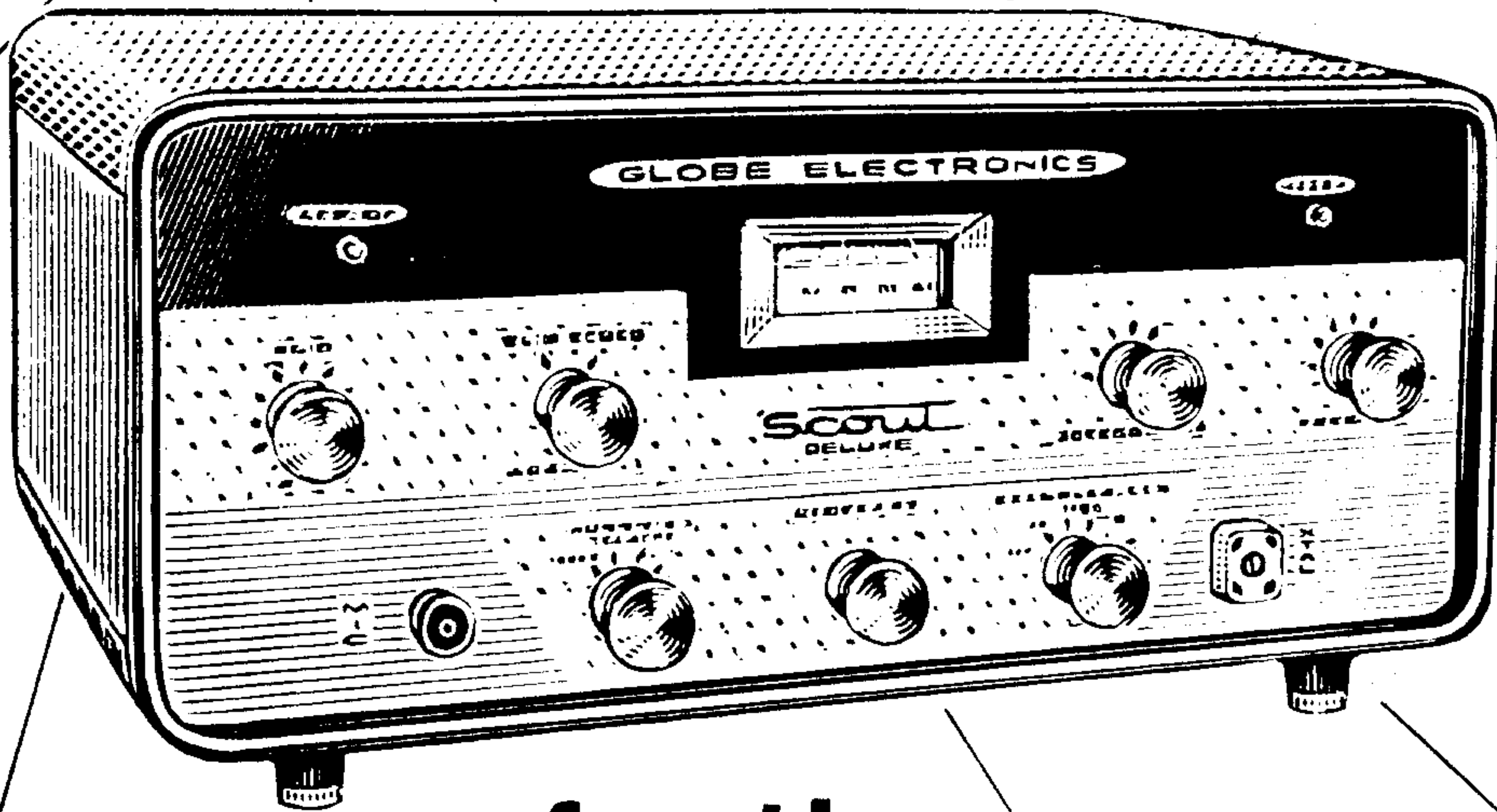

for the
GLOBE

Scowt
Deluxe

manufactured by
GLOBE ELECTRONICS
a division of
TEXTRON ELECTRONICS, INC.

SECTION II

GENERAL DESCRIPTION

2-1. GENERAL. The Globe Scout Deluxe Transmitter was designed to provide the amateur operator with a complete Phone - CW Transmitter, capable of operation on the amateur bands of 80 through 6 meters, and of sufficient power to contact both local and DX Stations. The transmitter is rated at 90 watts DC plate input power to the RF power amplifier, Radio Telegraphy (CW) and 75 watts Radio Telephone (AM) operation.

2-2 DESCRIPTION. The Globe Scout Deluxe Transmitter is completely self-contained in a metal cabinet of modern design. Cabinet dimensions are 6 inches high, 11 inches deep, and 15¹/₂ inches wide. Net weight is approximately 35 pounds. Adequate ventilation and heat disipation has been provided on both the top and bottom of the cabinet. The R.F. Power Amplifier and output circuits have been completely shielded and by passed. This and the fact that the RF Power Amplifier operates straight through on all bands, virtually eliminates T.V.I.

A pi network output circuit is used on 80-10 meters and will load a 50 to 300 ohm nonreactive antenna and also provides a high degree of harmonic antenuation when properly tuned, eliminating the necessity of a low-pass filter in most cases. Six meter output is independent of the pi network and is link coupled to the antenna. The amount of loading is varied by a separate variable capacitor mechanically coupled to the pi network antenna loading capacitor and adjustable from the front panel. Complete bandswitching of the transmitter is accomplished by a single switch. Also all bands have a common antenna receptacle.

2-3 CHASSIS REMOVAL. The chassis may easily be removed from the cabinet for inspection and servicing by removing the three screws on the top and the two feet and one screw on the bottom at the rear of the cabinet. However, care must be exercised to prevent damage to components on the underside of the chassis (See Section IV).

2-4 TUBE COMPLEMENT

TABLE I

Quan.	Type	Function
1	6CL6	Oscillator
1	6CL6	Buffer Doubler
1	6146	R.F. Power Amplifier
1	7027-A	Modulator
1	12AX7	Speech Amp/Driver
1	5R4GYB	Rectifier
1	6AQ5	Clamp Tube

SECTION III

SPECIFICATIONS

Power input- 90 watts CW, 75 watts AM
Plate Voltage to final - 600v
Power requirements 115 VAC 50/60 cy 300 watts
Type of modulation - Class A Plate

SECTION IV

UNPACKING

Upon receipt of your new Globe Scout Deluxe Transmitter, carefully unpack it from the shipping carton and remove the chassis from the cabinet by removing the chassis mounting screws. **WARNING:** There is very little clearance between components on the underside of the chassis and the cabinet flange, consequently great care must be observed when removing or replacing the chassis. Carefully inspect the transmitter for shipping damage; broken tubes, bent chassis or cabinet, etc. In case of damage, DO NOT ship the transmitter or make claim to Globe Electronics but immediately make a damaged goods claim to the carrier. Under no circumstances will Globe Electronics or any of its distributors accept equipment damaged in shipment for replacement or repair at the **company's** expense.

SECTION V

OPERATION

The Federal Communications Act of 1937, pertaining to amateur radio operation, provides that any person operating a transmitter in the amateur radio service, must have in their possession a station and operator's license issued to them by the Federal Communications Commission. Any violators thereof, will be prosecuted to the full extent of the law.

Globe Electronics and its distributors have made the sale of this transmitter on the assumption that the purchaser has complied with the law in acquiring the necessary licensing. We assume no responsibility in the event that action is brought against the purchaser for failure to comply with the laws pertaining to this type of radio service.

SECTION VI

DESCRIPTION OF CONTROLS

6-1 OFF - Gain Control. Combined AC power switch and audio gain control, All power is removed from the transmitter when the control is rotated to the extreme counter clockwise position.

6-2 Meter Switch. Inserts the meter in the final amplifier grid circuit to read grid current when placed in the left hand position and

6-2 (cont'd) final plate circuit to read plate current when placed in the right hand position.

6-3 Function Switch. Accomplishes necessary switching for tuning, CW, stand by and A.M.

6-4 Osc. Tuning. Tunes the oscillator tank circuit on 80-15 meters and the buffer doubler on 10-6 meters.

6-5 Band Switch. A multiple section ceramic rotary switch completes all necessary switching to change bands.

6-6 Plate Tuning. Controls a variable capacitor that tunes the final plate circuit to resonance at the desired operating frequency.

6-7 Antenna Loading. A multiple section variable capacitor that matches the final amplifier plate circuit impedance to the antenna impedance on 80-10 meters. On the 6 meter band, a separate variable capacitor ganged to the loading capacitor functions as a variable loading control for the 6 meter link.

SECTION VII

INSTALLATION & TUNE UP

WARNING

Before making any external connections to the transmitter, be sure the A.C. power cord plug is removed from the A.C. source receptacle. Also place the Off-Gain control in the off position.

7-1 Ground. The first external connection should be a good ground to the ground terminal on the rear of the transmitter. A no. 12 copper wire connected to a cold water pipe, or a 6-8 foot rod driven into the ground is usually satisfactory. Should difficulty be encountered in achieving a good ground on the higher frequency bands, it may be that the length of the grounding wire is such that it acts like an antenna. To remedy this trouble, shorten or lengthen the wire a few feet.

7-2 Microphone Input. Receptacle for crystal, ceramic, or high impedance dynamic microphone.

7-3 Key. Key jack for C.W. operation. Closed circuit type.

7-4 Xtal . Insertion of proper crystal or VFO output plug, allows operation on all amateur band 80 through 6 meters.

7-5 Antenna Receptacle. Located on rear of transmitter. For use on all bands, 80 through 6 meters.

7-6 Auxiliary Socket. Located on rear of transmitter. Provides 115v AC between pins 4 and 5 for antenna change over relay when function switch is in the C.W. or phone position. It also provides 6.3 volts between pins 6 and 1 or pins 7 and 2, and B plus at pin 3 (600v DC).

7-6 (cont'd) The VFO keying circuit may be connected between pins 1 and 8 to disable the VFO in the stand-by position. The Globe Electronics FCL-1, Speech Clipper and limiter, plugs directly into the auxiliary socket with the addition of a voltage dropping resistor (see section 9-3).

7-7 Power Cord, and Plug. Extends from the rear of the transmitter. Supplies AC power to the transmitter when connected to a 115 volt, 60 cycle, single phase alternating current source. Most home wall receptacles provide this type of power.

7-8 Tune-up Procedure. The following paragraphs describe the tune-up procedure for the Globe Scout Deluxe Transmitter, prior to the initial tune-up, the following preliminary precautions and procedures should be observed.

(a) Attach a good electrical ground to the chassis ground terminal (located next to the coaxial receptacle). See paragraph 10-2.

(b) Connect the antenna feedline with a coaxial connector such as the type 83-ISP. If a twinlead type feedline is used (80-10 meters), balun coils or an antenna tuner will be required to match the balanced feedline to the unbalanced transmitter output. Most common antennas of good design use the unbalanced feedline system, however, the folded dipole or rhombic require a balanced feedline, consequently, the balanced to unbalance line change over must be effected at the transmitter.

(c) Place all switches and controls in the following positions:

Off Gain-extreme counter clockwise off position.

Function Switch - Tune position.

Band Switch - to the desired band of operation

Meter Switch- Grid position

Plate Tuning - Extreme counter clockwise

Antenna Loading - Extreme counter clockwise

Oscillator Tuning - Extreme counter clockwise

(d) If crystal control is to be used, insert the proper crystal into the pins marked XTAL in the dual socket on the front panel. Refer to the crystal chart.

TABLE 2

Band	Band Frequency Limits	Crystal Frequency	XTAL Multiplication Factor
80	3.5 to 4.0 MC	3500 to 4000 KC	1
40	7.0 to 7.3 MC	3500 to 3650 KC	2
		7000 to 7300 KC	1
20	14.0 to 14.35 MC	7000 to 7175 KC	2
15	21.0 to 21.45 MC	7000 to 7150 KC	3
10	28.0 to 29.7 MC	7000 to 7425 KC	4
6	50 to 54 MC	8334 to 9000 KC	6

CAUTION: Allow adequate safety margin on band edge operation when selecting crystals to avoid "out of band operation".

(e). For VFO operation, insert the VFO output cable plug into the pins marked XTAL, (on the dual socket on the front panel) with the pin connected to the shielded braid into the left hand pin opposite the diamond. Into the remaining two pins, insert a jumper plug. (see figure 1). To key the VFO and transmitter simultaneously, connect one end of the center conductor of a length of single conductor microphone cable to the jumper in the plug shown in figure 1. Connect the other end of the center conductor to the tip connection of a standard phone plug. Connect the shield (at the VFO output plug end) to shield connection of the VFO output cable. Connect the other end of the shield to the remaining terminal of the phone plug. When the phone plug is inserted into the Key Jack on the VFO and key inserted in the Key Jack on the transmitter, they will both key simultaneously.

(f) Insert the A.C. power cord into a 115 volt AC receptacle.

(g) Turn on the power switch by rotating the off-Gain control clockwise until a click is heard. Do not advance the Gain control

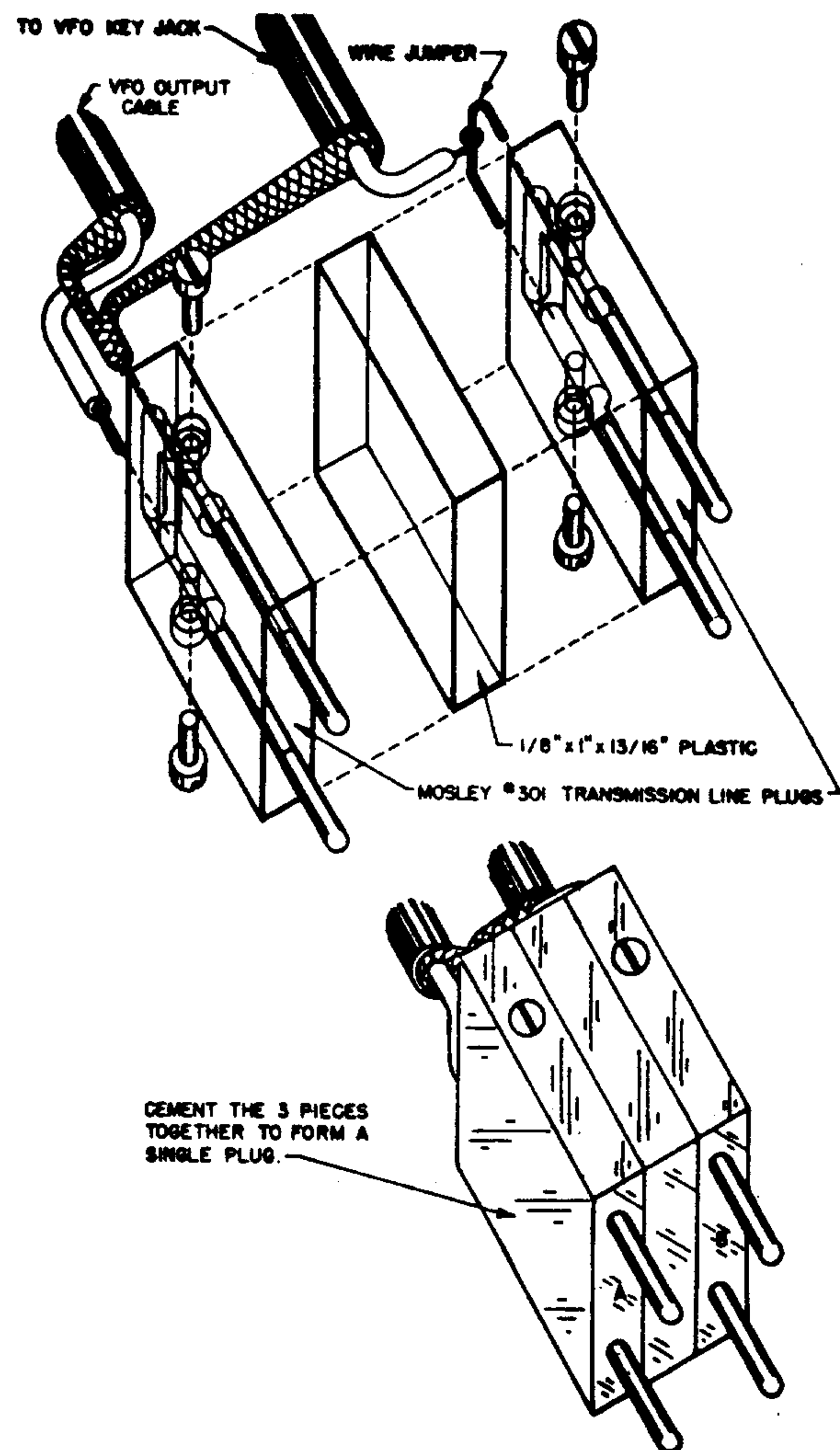

Figure 1
Jumper Plug

(g) cont'd. any further. Allow a minute for warm up.

(h) After the tubes have warmed up, tune the driver by rotating the Osc. Tuning knob in a clockwise direction until maximum grid current is indicated by the meter. Typical settings of the Osc. Tuning control knob are indicated by the markings on panel. Note: On the 20, 15 and 6 meter bands it is possible to obtain two maximum grid current indications. It is therefore necessary to follow the typical settings to avoid tuning the wrong harmonic. When tuning for the six meter band, an increase in current will be noted at the crystal doubling point, or approximately 16 MC. Do not stop at this setting. Continue with a clockwise rotation until a second increase in grid current is noted at the proper position as indicated by the front panel markings.

(i) Final grid current for any band should not exceed 3 milliamperes as indicated by the red mark on the top scale of the meter. Should grid current exceed 3 milliamperes, advance the Osc. Tuning control in a clockwise direction until the meter indicates no more than 3 milliamperes. Optimum transmitter power output will occur at a grid current of approximately 1.5 to 2.0 ma as indicated by the meter.

CAUTION

Do not exceed 3 milliamperes grid current on the final, as this will shorten tube life and may cause excessive harmonic radiation.

(j) Place the meter switch in the Plate position.

(k) Rotate the function switch to the CW position and then rotate the Plate Tuning condenser in a clockwise direction until a pronounced dip in plate current is indicated by the meter. Tune for minimum current, indicating resonance. (The antenna must be attached or arcing of the tuning condensers may occur) On some bands two dips in plate current may occur. This is true on 80 meters where another dip in plate current will appear near the extreme clockwise rotation of the knob. This dip tunes to the 40 meter band and would result in operation on the wrong frequency. However, if the Plate Tuning control knob settings are approximately as indicated in Figure 2 improper operation should not be encountered.

(l) Place the meter switch in the grid position. Readjust the Osc. Tuning control if necessary to indicate the proper amount of grid current as shown by the meter. Return the meter switch to the Plate position.

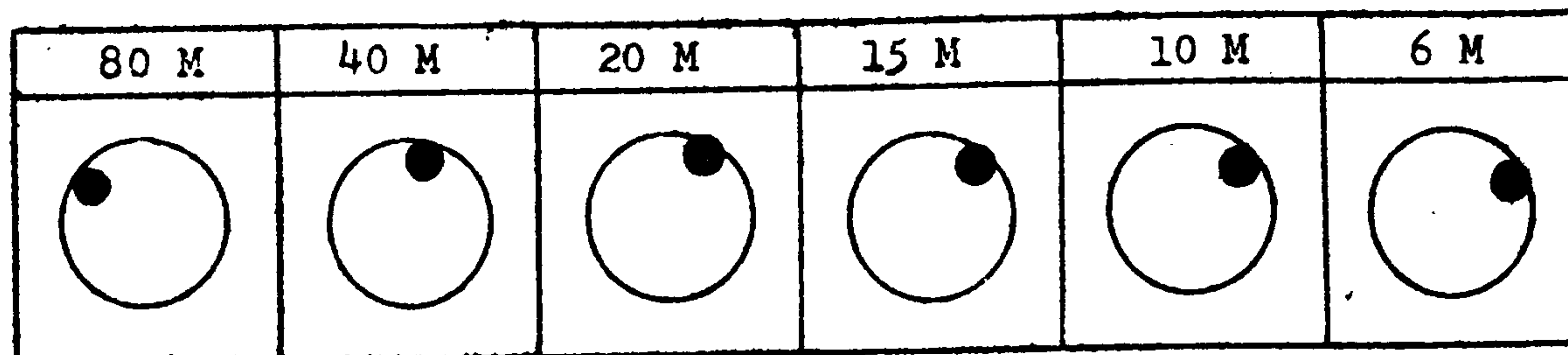

Figure 2

Approximate Final Plate Tuning Positions

(m) Now that the minimum final plate current has been obtained, antenna loading may be accomplished by advancing the Antenna Loading control slowly in a clockwise direction. As the control is advanced, an increase in plate current will be noted on the meter. The control should be advanced until an indication of 150 ma. is reached.

(n) Retune the Plate Tuning control for a minimum current dip. The minimum current indication should be higher than before, indicating the antenna is loading.

(o) Repeat steps m and n until the desired amount of antenna loading has been achieved. At no time should the transmitter be loaded beyond the point where the final tube is drawing more than 150 ma. Doing so, will not only reduce the power output, but will shorten the life, if not damage, the 6146 RF power amplifier due to exceeding its ratings.

(p) Place the meter switch in the Grid position and again check the grid current and re-adjust if necessary as per step l.

(q) Rotate the function switch to the Stand-By position and insert a telegraph key into the jack on the rear of the transmitter marked Key.

The tune-up procedure for CW operation is now completed and the transmitter may be placed into CW operation.

NOTE

When changing bands, steps b through q inclusive, should be repeated. When changing frequency within a band the Osc. tuning should be re-adjusted as per step l. The Plate tuning and antenna loading controls will need a slight amount of re-adjustment. The amount depending upon the amount of frequency change. Adjust as per steps i and o.

SECTION VIII

RADIO TELEPHONY OPERATION (A M)

After the transmitter has been properly tuned for CW operation, it may be placed in AM operation as follows:

8-1. Place the function switch to the Standby position.

8-2. Connect a crystal, ceramic, or high impedance dynamic microphone to the Mic input connector on the front panel.

8-3. Place the function switch to the A.M. position.

8-4. Place the meter switch in the Plate position.

8-5. Adjust the Antenna Loading and the Plate Tuning controls, if necessary to load the transmitter so the final plate circuit is drawing no more than 125 ma.

8-6. Advance the Gain control in a clock-wise direction while speaking into the microphone in a normal voice. When approximately a 5% variation of the final plate current is noted on the meter, maximum modulation has been reached. The knob pointer will be approximately in the "9 o'clock to 12 o'clock" position for an average speaking voice and mike. All preliminary procedures have now been performed and the transmitter may now be used for AM operation.

SECTION IX

ACCESSORY INSTALLATION AND OPERATION

The Globe Electronics 755-A (30-10 m) VFO may be used with the Globe Scout Deluxe Transmitter. Following are some suggestions for its use.

9-1. "Automatic phone operation with the VFO."

(a) Cut a piece of two-conductor cord to a sufficient length to reach from the VFO to the AUX socket on the rear of the transmitter.

(b) Strip 3/4" insulation from each wire at one end of this cord.

(c) Strip 1/2" of insulation from each the wires on the other end of this cord.

(d) Insert one of the 3/4" stripped leads into pin 8 of an octal plug.

(e). Remove the bakelite shell from the phone plug and slip the shell over the two conductor cord.

(f). Connect the other end of the wire used in step 5 to the "tip" terminal of the phone plug.

(g). Connect the remaining wire at the phone plug end, to the other terminal of the phone plug. Screw the bakelite shell onto the phone plug.

(h). Connect the remaining wire, at the octal plug end, to pin 1 of the octal plug.

(i) Insert the octal plug into the AUX socket of the transmitter.

(j) Insert the phone plug into the key jack on the VFO. When the function switch is placed in the AM, CW, or tune position, pin 8 of the AUX socket is shorted to ground (pin 1). This completes the cathode circuit of the VFO through the cord connected to VFO key jack. When the function switch is placed in the standby position, the short between pin 8 and ground on the AUX socket is removed, thus opening the cathode circuit of the VFO. The Calibrate switch on the VFO should be left in the off position, then when the transmitter is energized the VFO will become energized also. Use the Calibrate position on the VFO switch only to spot check or "zero" in on a particular frequency with the transmitter in the Standby position. For VFO out-put connections, see Section VII paragraph 7-8 (e).

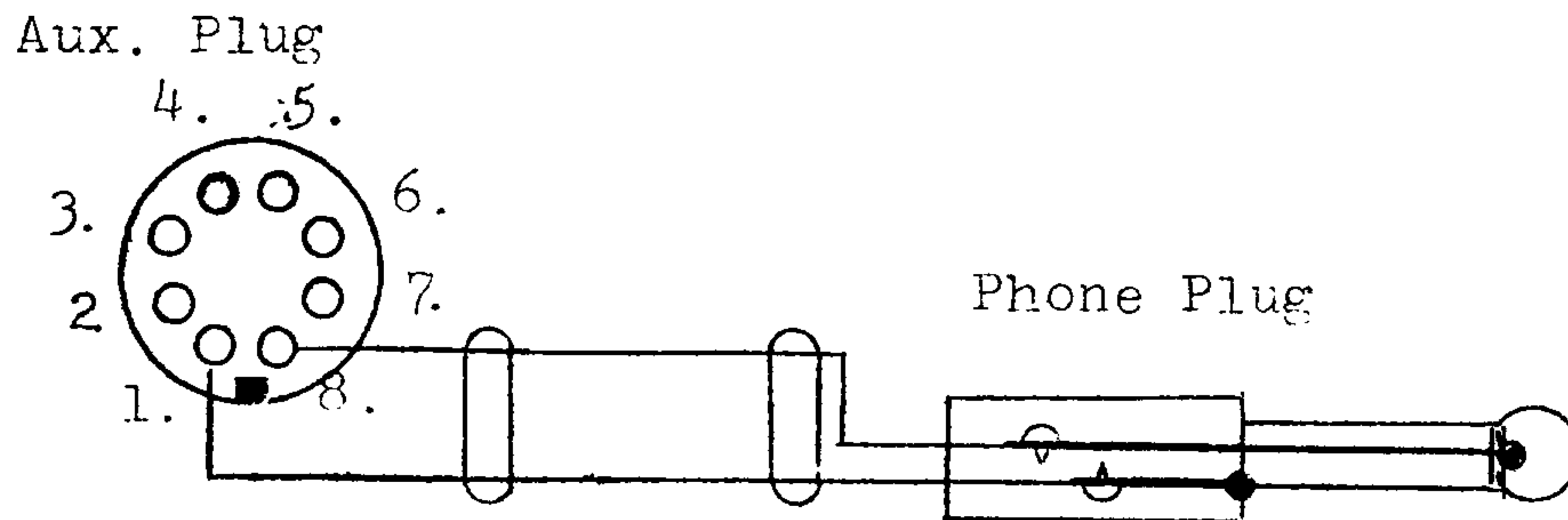

Figure 3
Automatic Phone Operation Cord

REQUIRED PARTS LIST

Quan.	Description	Globe Electronics Part No.
1	Standard Phone Plug	2001-003
1 foot*	2 Conductor POSJ cord	2700-001
1	Octal Plug and Cap	2001-009 & 2001-012

* This length is used in the case where the VFO is set next to the transmitter.

9-2. For 6 meter VFO operation, the Globe Electronics VFO, Model 6-2 is recommended. The preceding connections apply equally well to this VFO.

9-3. Installation of the Globe Electronics FCL-1 Speech Clipper-Limiter.

The Globe Scout Deluxe is designed for direct insertion of the FCL-1 into the AUX socket after the addition of a dropping resistor to the FCL-1. However on the FCL-1, there is no connection between pin 8 of the input plug and pin 8 of the output socket. If it is desired to operate the VFO cathode keying circuit with the function switch while using the FCL-1, it will be necessary to make the following change.

(a) Remove the four self tapping screws and remove the cover from the FCL-1.

(b) Strip $3/4$ " of insulation from one end of a 11" piece of hookup wire and $1/4$ " of insulation from the other end.

(c) Insert the end of the wire with $3/4$ " of insulation removed into pin 8 of the input plug. (S)

(d) Dress the wire down to and along the chassis toward the output socket. Solder the free end of this wire to lug #8 of the output socket. (S)

(e) Remove the 47K 1w resistor (R15) from C-8 and terminal 1 of TS-1.

(f) Connect one end of a 82K 2 watt resistor to terminal C-8 of the can type filter condenser. (S)

(g) Connect the other end of this resistor to lug 1 of TS-1. (S)

(h) Check for shorts and loose solder drippings and remove if necessary.

(i) Replace the cover and the four self tapping screws securing it. This completes the modification. Insert the FCL-1 input plug into the AUX socket then insert the AUX plug (if any) into the FCL-1 output plug. Connect the FCL-1 microphone output cable to the microphone connector on the front of the panel. Connect the microphone to the MIC connector on the FCL-1. The FCL-1 is now ready for adjustment and use. (See FCL-1 manual for operation and adjustment.)

SECTION X

OPERATING HINTS

10-1 GENERAL. Some operators attempt to place equipment into operation before they read the instructions or understand how to operate the equipment, then blame the equipment because it fails to function properly. A careful study of Section VII Operating Procedures, and the observance of suggestions contained in the following paragraphs, will assure the operator of proper and efficient operation of the transmitter.

10-2 GROUNDING THE TRANSMITTER. A good electrical ground connection to the transmitter chassis is essential for efficient operation and proper loading. The ground wire length should be kept as short as possible to prevent its action as a leg of the antenna. Such action may cause the chassis and cabinet to be very "hot" with RF, prevent proper loading of the final or cause modulator squeal due to RF feedback into the speech input stage. The use of several ground wires, each a different length and each connected to an independent ground point, may prove to be helpful. Such ground wires, for example, may be one 4 feet, one 7 feet, and one 15 feet in length.

10-3 ANTENNA CONSIDERATIONS. One antenna receptacle is provided for use on all bands, 80-6 meters. For higher frequency bands, beam antennas are to be desired because of the higher gain and directional characteristics obtained. Where space is limited some type of vertical antenna may be the most practical installation. On the lower frequencies dipoles or folded dipole antennas are economical and easily installed, however, the folded dipole antenna must be used with a matching device between feedline and transmitter as previously mentioned. A long wire antenna can be used with an antenna tuner and has some directional qualities but is most likely to enhance TVI problems. For general all around use, lowest cost, ease of maintenance, and good performance, the doublet or the folded dipole antennas are recommended. A chart of antenna lengths for each band, and formulas for computing the length of an antenna for a specific frequency, are given in Table 3. When an antenna is made to the correct length for a specific operating frequency, the length of the feedline is not critical. In practice this is practically impossible, so the feedline should be kept as near to an even multiples of one-half wave length as possible. Thus any mis-match at the antenna end will not be exaggerated at the transmitter end.

10-3 (cont'd)

A 72 or 52 ohm coax (preferably 72 ohm) feedline should be used on a doublet antenna. A 300 ohm feedline should be used on a folded dipole antenna. The junction of the feedline and antenna center should be kept as close as possible as even a small amount of fanning of the feedline may cause a slight mis-match.

Should the antenna be less than one-half a wave length above ground, the lengths given in Table 3 may not hold true. In this case, it may be necessary to adjust the length of the antenna for the best match.

TABLE 3

ANTENNA CHART

Band	1/2 Wave Dipole 72 Ohms	1/2 Wave Folded Dipole 300 Ohms
10	15'9" to 16'6"	15'8" to 15'5"
15	21'11" to 22'3"	21'9" to 22'1"
20	32'10" to 33'3"	32'4" to 33'0"
40	64'3" to 66'3"	63'6" to 66'0"
80	118'0" to 133'0"	116'0" to 132'0"

For $\frac{1}{2}$ wave dipole in feet L - $\frac{468}{\text{Specific Freq. (MC)}}$

For $\frac{1}{2}$ wave folded dipole, in feet L - $\frac{462}{\text{Specific Freq. (MC)}}$

If further information concerning antennas and feedlines is desired, it is suggested that you read some of the excellent antenna handbooks, such as the one published by the ARRL, or the Beam Antenna Handbook by William I. Orr. Also the Radio Handbook, and the Radio Amateur's Handbook, devote at least one or two chapters to antennas and feedlines.

10-4 ANTENNA CHANGE OVER RELAY. The use of an antenna changeover relay is a very great operating convenience. Any coaxial type, or DPDT, 115V AC relay with adequate insulation may be used in conjunction with the Globe Scout Deluxe Transmitter. Suggested method of relay connection is shown in figure 4.

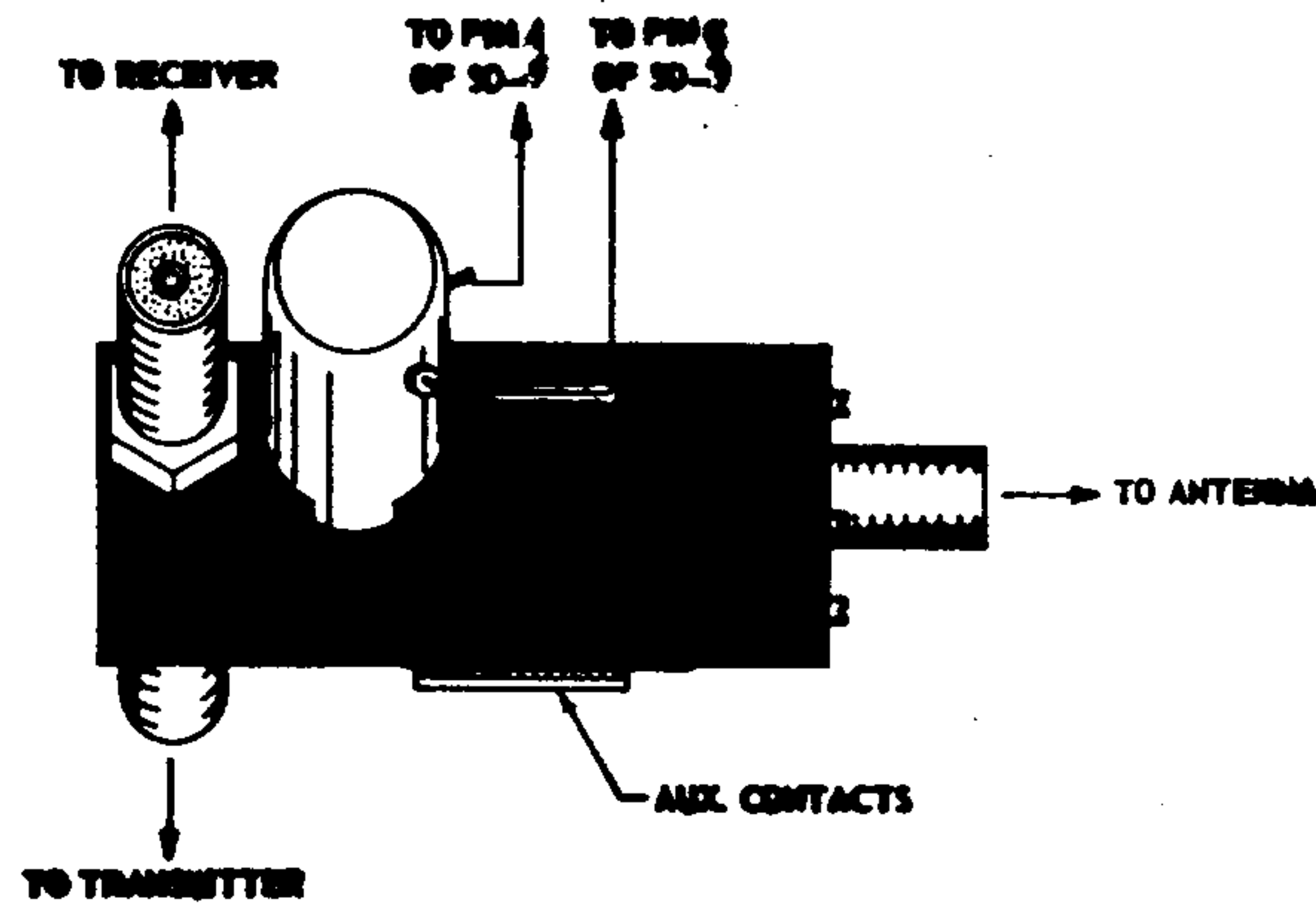

Figures 4
Antenna Relay

10-5 PI NETWORK TUNING. Tuning of the pi network is not too difficult. It should be noted, however, that it is possible to tune the pi network to an undesirable harmonic of the desired frequency. The correct method to determine the proper frequency is to note the final plate current dips. The final plate current dip of the desired frequency will be more pronounced than that of a harmonic. No trouble should be encountered if the Typical Final Plate Tuning Settings, Figure 2 are followed.

10-6 OSC. TUNING. As in the above case of the pi network, it is also possible to tune the driver stage to the wrong frequency. However, in tuning the driver stage, in some instances, it is necessary to tune the circuit to the second or third harmonic of the fundamental frequency in order to obtain the desired frequency in the final amplifier. No difficulty should be encountered in tuning the driver stages if the instructions set forth in paragraph VII, step h are carefully observed.

10-7 ANTENNA LOADING. Loading of the final amplifier is described in detail in Section VII, steps j-q inclusive. On all bands, loading of the final amplifier (with the antenna attached) should not require an excessive amount of rotation of the Plate Tuning control knob to re-dip the circuit (Section VII, steps (M) and (N)). Should an excessive amount of rotation of this control be necessary, after once resonating at minimum loading, excessive antenna reactance is indicated. The common method to eliminate this reactance is to change the physical dimensions and/or the location of the antenna, so that when the Antenna Loading Control is advanced to full load (125 ma for AM and 150 am for CW) very little retuning of the Plate Tuning Control is required to again obtain resonance of the final amplifier.

SECTION XI

IN CASE OF DIFFICULTY

11-1 GENERAL. This section deals with service procedures in the event that repairs become necessary. The most likely causes for each type of trouble are given. The operator should be able to ascertain the nature of the malfunction from this chart and thus

11-1 (cont'd)

easily repair the equipment. A voltage and resistance chart are also given as a service aid.

WARNING

Operation of this equipment involves the use of high voltages which are dangerous to life. Observe all safety precautions! Do not attempt to make adjustments inside the equipment, or change tubes with any power on. Disconnect (UNPLUG) the AC power cord and short out the filter condensers with an insulated screw driver, before touching any high voltage components.

11-2 MALFUNCTIONS AND PROBABLE CAUSES.

TABLE 5

Symptom	Probable Cause
1. Transmitter will not operate when AC power is applied.	1-1 Defective 3 amp fuse
	1-2 Power cord not making contact in wall socket.
	1-3 Defective power cord.
2. Fuse blows when AC power is applied.	2-1 Shorted tube or tubes
	2-2 Shorted line filter chokes.
	2-3 Shorted line by pass capacitor.
	2-4 Shorted filter capacitor.
	2-5 Shorted by pass capacitor.
	2-6 Shorted filament wiring.
3. Lack of final grid current.	3-1 Defective 6CL6's, 6146, 6AQ5, or 5R4GYB tube.
	3-2 Key contact not closed.
	3-3 Key jack defective.
	3-4 Defective components in the oscillator, buffer doubler, or final grid circuit.
	3-5 Defective crystal or VFO.
	3-6 Lack of B plus voltage.

4. Final plate circuit will not tune properly.

- 4-1 Overloaded pi-network
- 4-2 Improper driver tuning
- 4-3 Final plate circuit tuned to a harmonic.
- 4-4 Shorted final tuning condenser.
- 4-5 Driver stage tuned to the wrong harmonic for band in use.
- 4-6 Defective band switch.
- 4-7 Improper antenna for band in operation.

5. Antenna will not load.

- 5-1 Defective antenna system.
- 5-2 Defective antenna connector or transmission line.
- 5-3 Condensers not turning due to a loose shaft coupling or knob.
- 5-4 Wrong antenna for band in use.
- 5-5 Final plate circuit tuned to a harmonic.
- 5-6 Lack of proper drive.
- 5-7 Defective 6146.
- 5-8 Shorted or defective antenna loading condenser.
- 5-9 Defective band switch.
- 5-10 Improper ground system.

6. No modulation on carrier.

- 6-1 Defective 12AX7 or 7027A Tube.
- 6-2 Defective microphone or microphone cable.

Table 5 (cont'd)

- 6-3 Defective or shorted gain control.
- 6-4 Defective or shorted modulation choke.
- 6-5 Function switch in CW position.
- 6-6 Defective function switch.
- 6-7 Loss of B plus voltage to the modulator circuit.

- 7: Hum in modulation
 - 7-1 Defective 12AX7 or 7027A Tube.
 - 7-2 Defective ground system on microphone cable.
 - 7-3 Microphone cable "open"
 - 7-4 Defective filter capacitors.

- 8. Squeal in modulation
 - 8-1 Insufficient antenna loading.
 - 8-2 Defective ground system.
 - 8-3 Microphone cable is a $\frac{1}{4}$ wave length at operating frequency.

- 9. Arcing of final tuning and/or antenna loading capacitor.
 - 9-1 Insufficient antenna loading.
 - 9-2 Defective antenna system.
 - 9-3 Bent condenser plates.
 - 9-4 Antenna not connected.

- 10. Low B Plus voltage
 - 10-1 Defective 5R4GYB tube.
 - 10-2 Leaky filter capacitor.
 - 10-3 Leaky by pass capacitor.
 - 10-4 Low AC line voltage.
 - 10-5 Final loaded too heavy.

Table 5 (cont'd)

11. Final plate current does not drop when key contacts are opened
- 11-1 Defective 6AQ5A tube.
 - 11-2 VFO calibrate switch on.
 - 11-3 Short in key circuit.
 - 11-4 Open resistor in clamp tube circuit.
 - 11-5 Parasitic oscillations.

11-3 TYPICAL VOLTAGE READINGS. The voltage readings given in Table 4 are typical for the conditions as set forth. Some allowances must be given to compensate for inaccuracies in the meter, and also the tolerance of the components.

WARNING

USE EXTREME CAUTION WHEN TAKING VOLTAGE READINGS. HIGH VOLTAGES DANGEROUS TO LIFE ARE INVOLVED.

CONDITIONS: AC line voltage-115 volts, test meter-20,000 ohms/volt; band switch placed in the 10 meter position, Function switch placed in the phone position, final loaded plate current - 125 ma, final grid current 1.8 ma, meter connected from specified tube pin to chassis ground, except where otherwise stated, crystal controlled, no modulation.

Tube Type	Pin Number									
	1	2	3	4	5	6	7	8	9	
V-1 6CL6	+3.5	-26.5*	+155	6.3AC	0	+200*	0	+155	-26.5*	Voltage
Oscillator	140ohm	47K	28K	0	0	18K	0	28K	47K	Resistance
V-2 6CL6	0	-30*	+90	6.3AC	0	+195*	0	+90	-30*	Voltage
Buffer Doubler	0	6.8K	30K	0	0	18K	0	30K	6.8K	Resistance
V-3† 6146	0	0	+155	0	-33.5*	0	6.3AC	0	†	Voltage
Power Amplifier	0	0	68K	0	22K	0	0	0	19K	Resistance
V-4 6AQ5A	-47	0	0	6.3AC	+155	+183	-47			Voltage
Clamp Tube	22K	0	0	0	68K	38K	22K			Resistance
V-5 5R4GYB	NC	+580§	NC	740AC	NC	740AC	NC	+580§		Voltage
Rectifier	NC	20K	NC	130ohm	NC	140ohm	NC	20K		Resistance
V-6 7027A	+385	0	+580	+380	0	0	6.3AC	+33		Voltage
Modulator	44K	0	16K	20K	2 meg.	2 meg.	0	390ohm		Resistance
V-7 12AX7	+155	0	+1.8	6.3AC	6.3AC	+80	0	0	0	Voltage
Audio Amp Driver	500K	2 meg.	6.8K	0	0	500K	2 meg.	0	0	Resistance

* Measured with a 750 uh R. F. choke in series with test lead.

† Do not measure plate voltage at the plate cap of the 6146. Instead obtain this voltage at the "cold" or B Plus end of the RF choke in the final plate circuit. Voltage reading; 580 V.

§ 5.0VAC measured between pins 2 and 8.

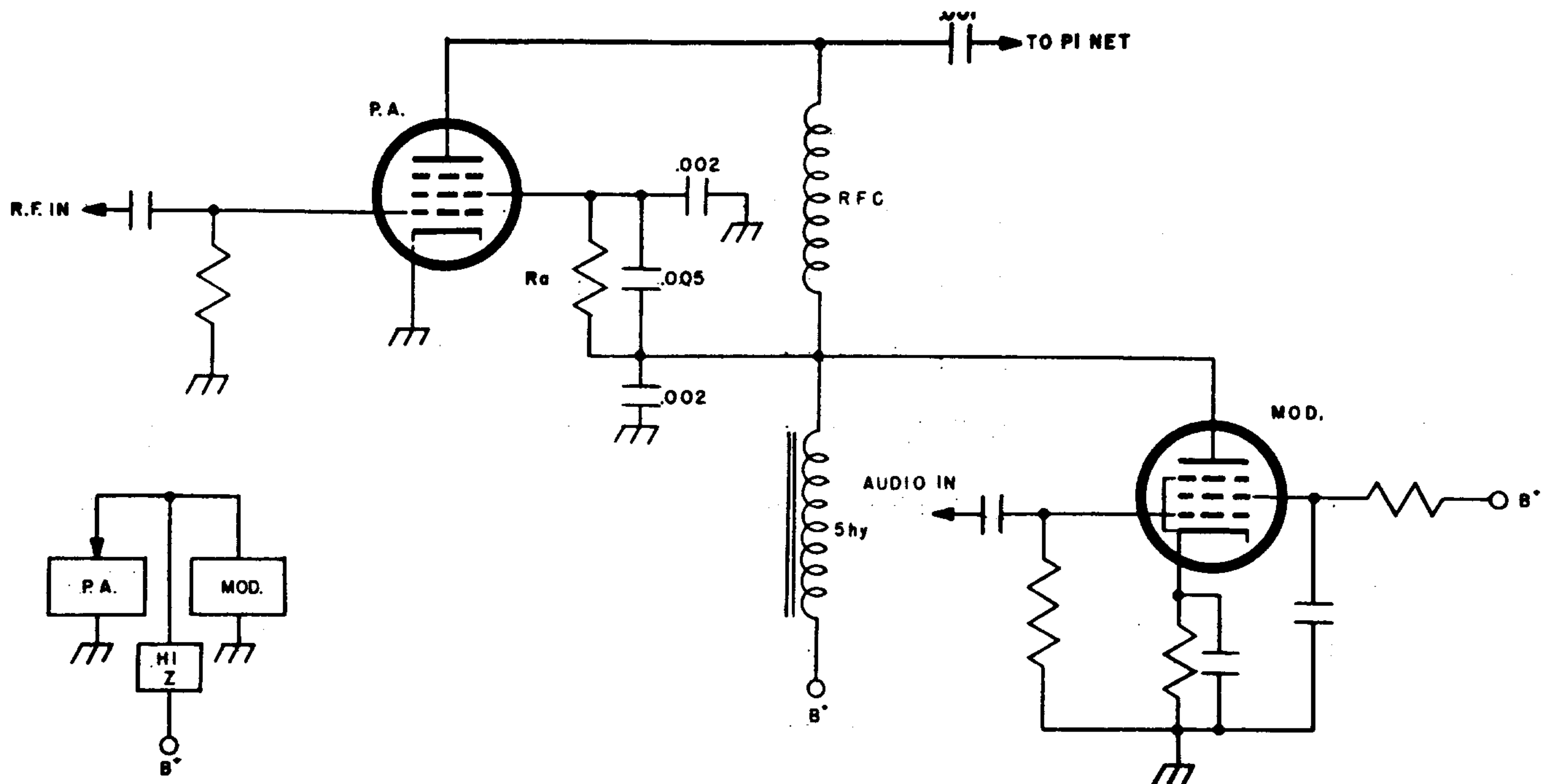

Figure 5
Modulator Schematic

The audio voltages developed by the modulator is therefore presented across the RF power amplifier which in turn modulates that stage. The peak to peak audio voltage developed across the RF power amplifier, must (as in any high level plate modulation) equal twice the applied D.C. voltage to that stage in order to accomplish 100% modulation; i.e. when the audio voltage swings to a positive peak equal to the applied DC voltage, the two voltages add, producing a voltage equal to double the DC voltage therefore quadrupling the power output (100% positive modulation). When the audio voltage swings to a negative peak equal in magnitude to the positive applied DC voltage, the two voltages, being of equal magnitude but of opposite polarity, cancel each other out producing no voltage and therefore cutting the RF power amplifier off producing no power output (100% negative modulation).

The 5 henry choke produces a 1:1 coupling ratio, therefore the modulator and RF power amplifier must be so designed as to have the same load impedance to accomplish a good match. The modulator tube is run as a class A amplifier to provide good linearity.

SLOBBE DELUXE

NOTES:
 ALL RESISTORS
 OTHERWISE NC
 ALL CAPACITORS
 UNLESS OTHER

