

1946

GLOBE TROTTER TRANSMITTER

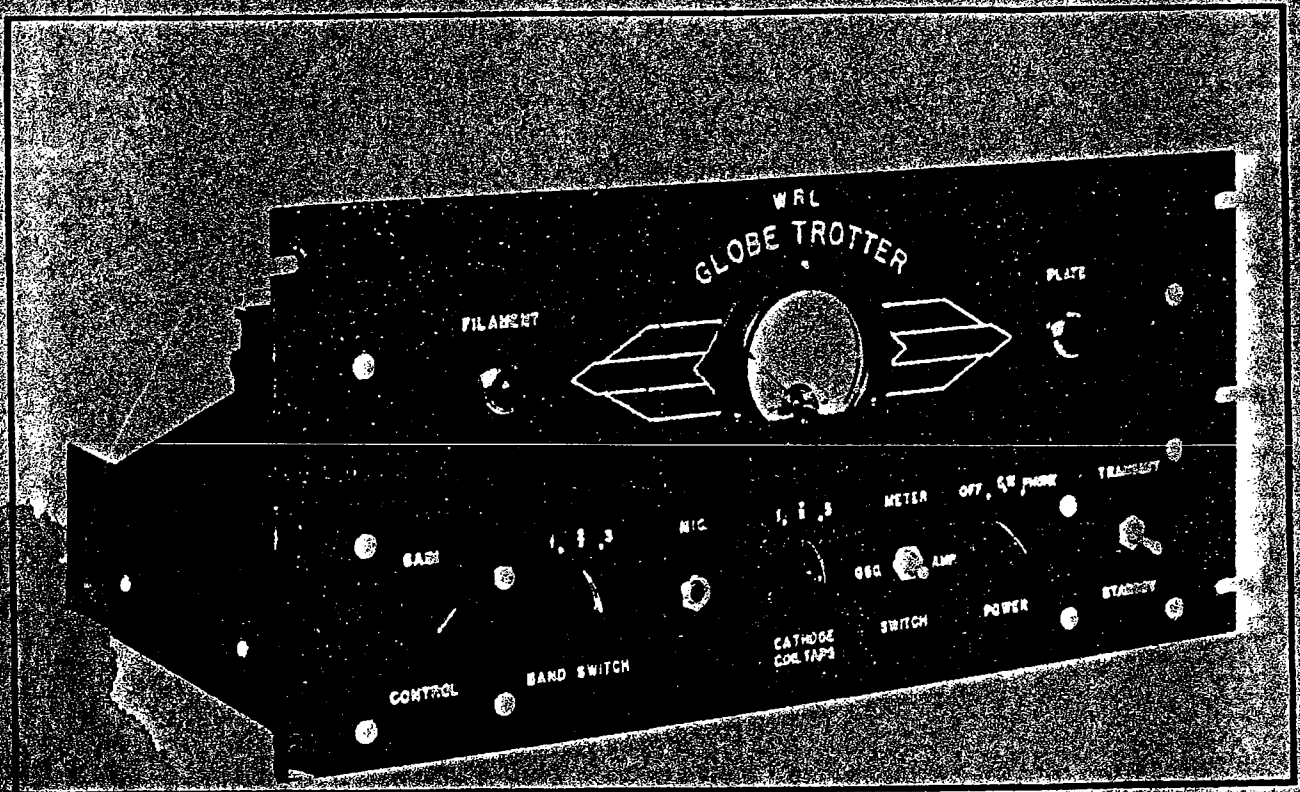

RT. MANUALS
BOX 802
COUNCIL BLUFFS, IOWA 51502

K5MO

WRL GLOBE TROTTER

GENERAL DESCRIPTION

Tube-complement: 6L6 Oscillator - 807 Final - (2) 5U4 Rectifiers -
6SJ7 Speech Amp. - 6N7 Driver - (2) 6V6 Modulators.
Power consumption 125 watts

The Globe Trotter incorporates the new hot cathode Xtal oscillator circuit which allows complete band coverage from 10 to 80 meters using only a 40 or 80 meter Xtal. A keying jack in the cathode of the oscillator allows break in operation on CW. The cathode coil switch, now serves to switch one of three different Xtals into the osc grid and the Band Switch serves to switch one of three sets of coils into the osc and final plate circuits. One of the power supplies is used for the final and modulators while the other supplies the Osc, speech and driver stages. The speech stage is conventional and allows the use of a Xtal or high impedance dynamic mic. The driver is connected in parallel as are the modulators and will supply sufficient modulation to the final stage.

Provisions have been made for an Antenna changeover relay and for remote operation of the transmitter which is explained in the tuning procedure.

TUNING PROCEDURE FOR GLOBE TROTTER

1. Set power switch to off position and Sw2 to Stand By.
2. Insert line cord provided, in receptacle of transmitter, and into a 110V. AC outlet.
3. Insert Mic. or key as desired.
4. Plug the Xtals into their respective sockets. See Coil and Xtal Chart.
5. Plug the desired coils into their respective sockets.
6. Check to see if tubes are in proper sockets.
7. Turn power switch to CW and allow one minute warm-up.
8. Set the Band switch and the Cathode switch to the proper position. (see coil chart).
9. Set meter switch to osc.
10. Turn on Transmit switch.
11. With an alignment screwdriver tune the condenser in the Osc. coil to resonance as indicated by a sharp dip in current on the meter.
12. Turn meter switch to Amp and tune the condenser in the final coil for resonance as indicated by a sharp dip in plate current. Always tune for minimum dip on the meter.
13. Turn off Transmit switch and attach the Antenna feeders to the two feed thru's at the rear of the Chassis.
14. Turn on the Transmit switch and again tune the final coil for minimum dip. This time it should be much higher as the final is loaded. It should be from 75 to 100 MA when fully loaded.
15. Turn off Transmit switch and turn power switch to Phone position allowing one minute warm-up for the tubes.
16. Turn on Transmit switch, advance gain approx half way for full modulation.

COIL AND XTAL CHART

BAND	XTAL & SOCKET	OSC. COIL & SOCKET	FINAL COIL & SOC.	BAND SW.	CATHODE SW.
10M	40M-Xtal 3	10M.osc-Osc 3	10M.F.-Final 3	3	3
20M	40M-Xtal 3	20M.osc-Osc 3	20M.F.-Final 3	3	3
40M	40M-Xtal 2	40M.osc-Osc.2	40M.F.-Final 2	2	2
80M	80M-Xtal 1	80M.osc-Osc.1	80M.F.-Final 1	1	1

For remote or push to talk operation, and ant. relay operation the following is recommended.

There are four terminals mounted on a bakelite strip at the rear of the chassis. The two terminals to the right (looking at the rear) supply 110V. AC when the Transmit switch is turned on, and to these terminals may be attached an antenna change-over relay. The two terminals to the left may be connected to a relay which can be energized by a mic. switch. The relay then acts to ground the CT of the power transformer secondaries.



FRONT VIEW - PANEL

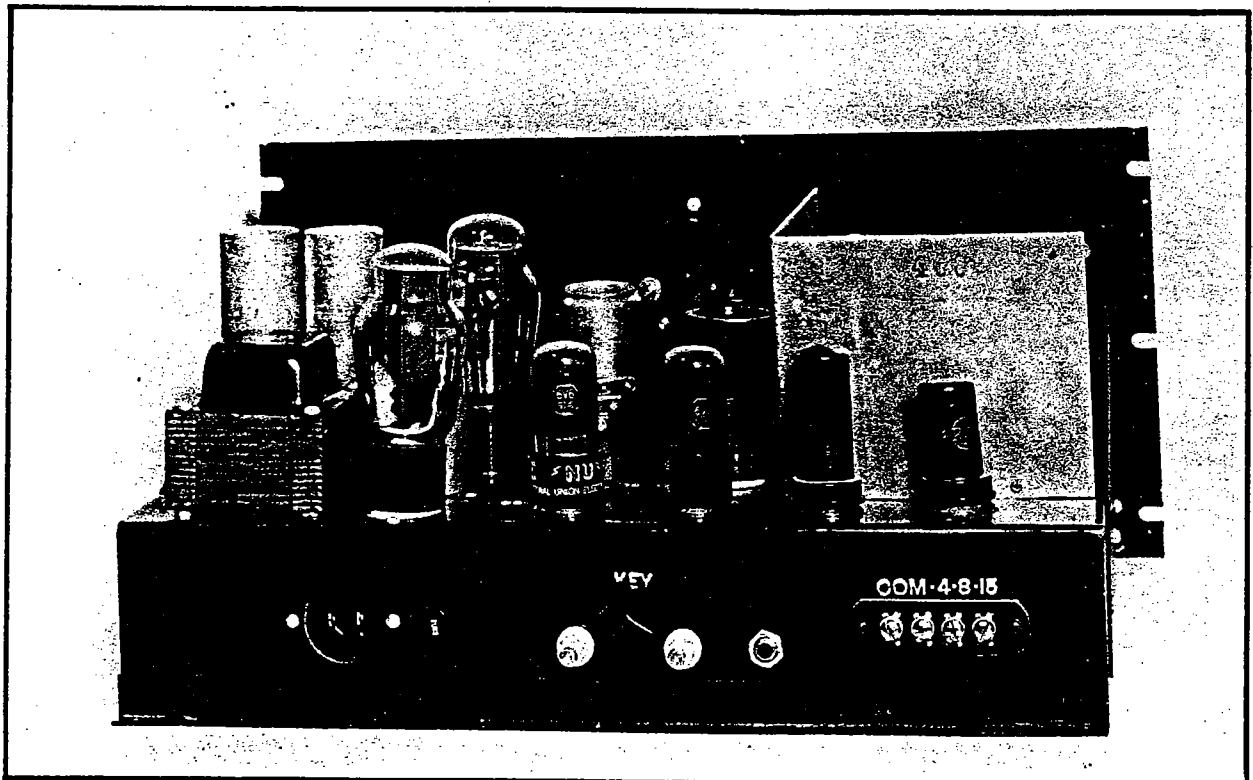

REAR VIEW

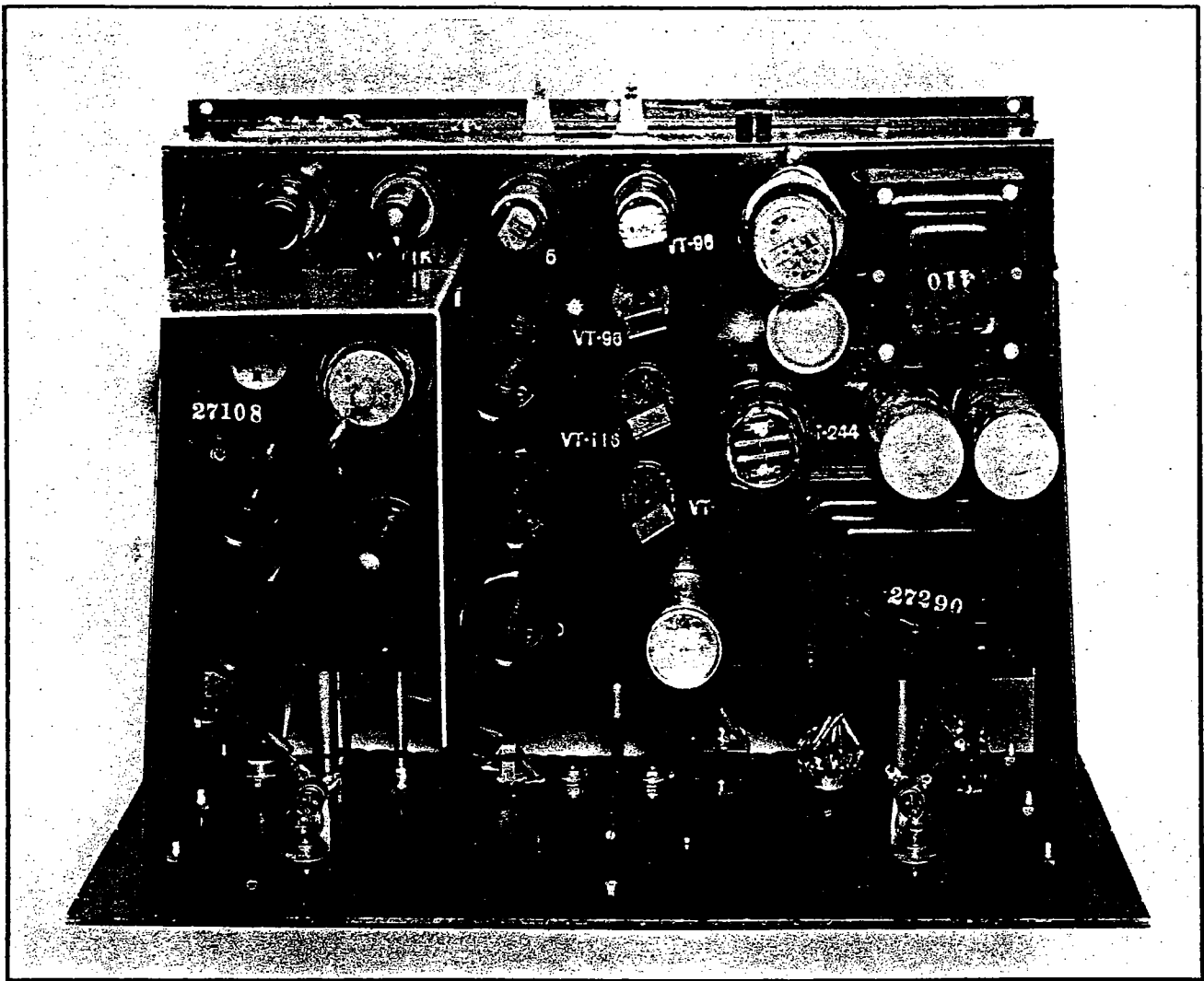

TOP VIEW

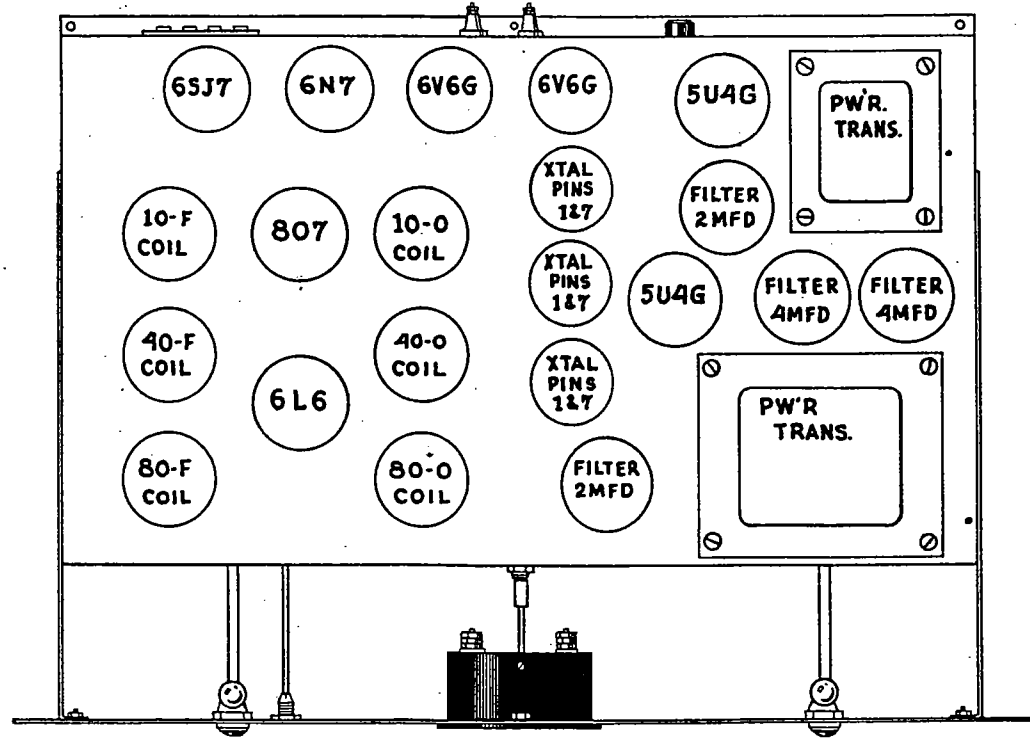

PLAN OF TOP VIEW

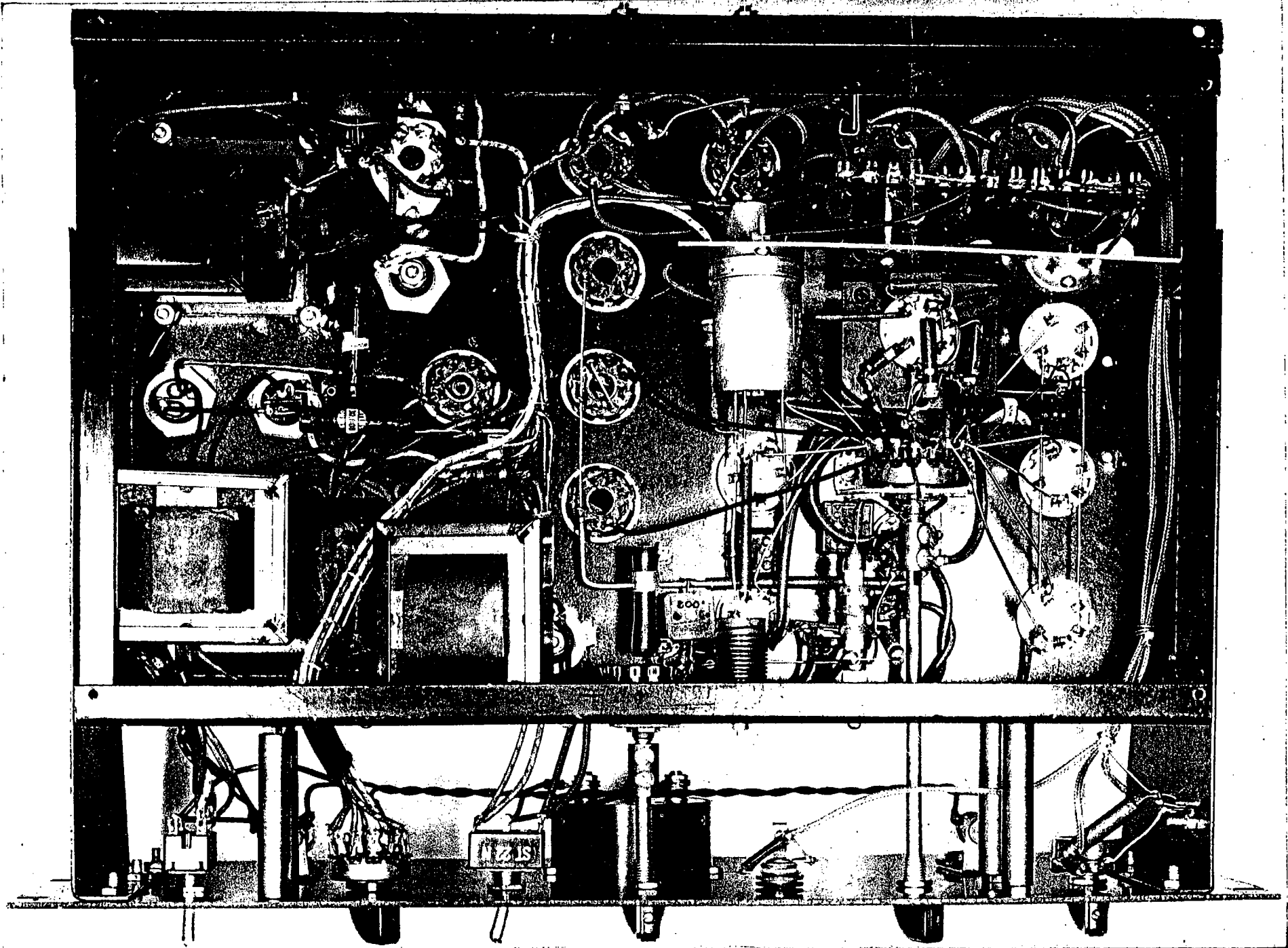

GLOBE TROTTER

REAR VIEW RESISTOR CONDENSER TERMINAL BOARD —
MOUNTED ON ALUMINIUM SHIELD WITH FILTER COND. PACK.

14 15 16 17 18 19 20 21 22 23 24 25 26

CENTER TERMINAL
OF CONDENSER
NEAREST FRONT
EDGE OF CHASSIS.

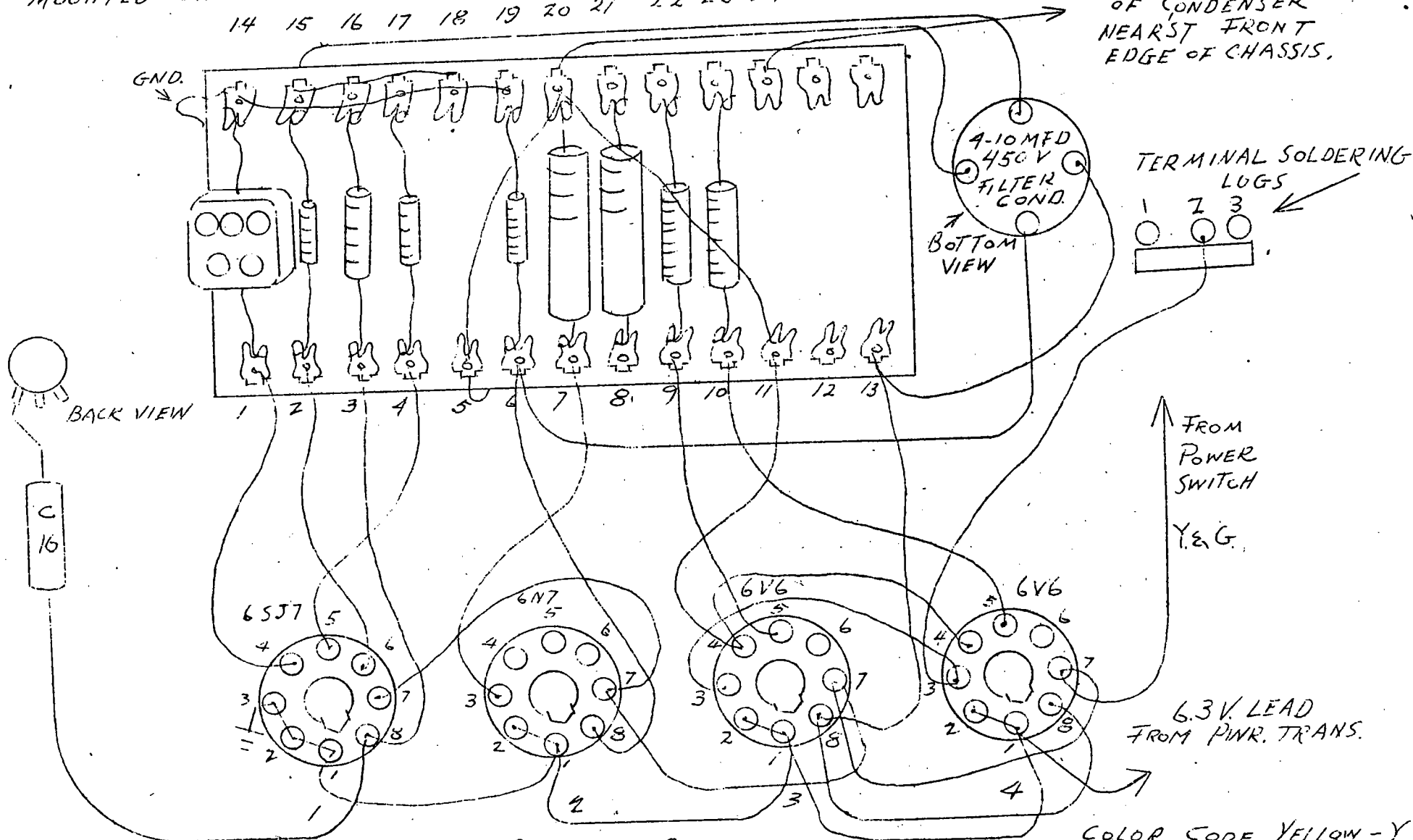

TERMINAL SOLDERING
LUGS
1 2 3

FROM
POWER
SWITCH
Y & G.

6.3V LEAD
FROM PWR. TRANS.

COLOR CODE YELLOW - Y
GREEN - G.

BOTTOM SOCKET VIEW

SW-1 Band Change

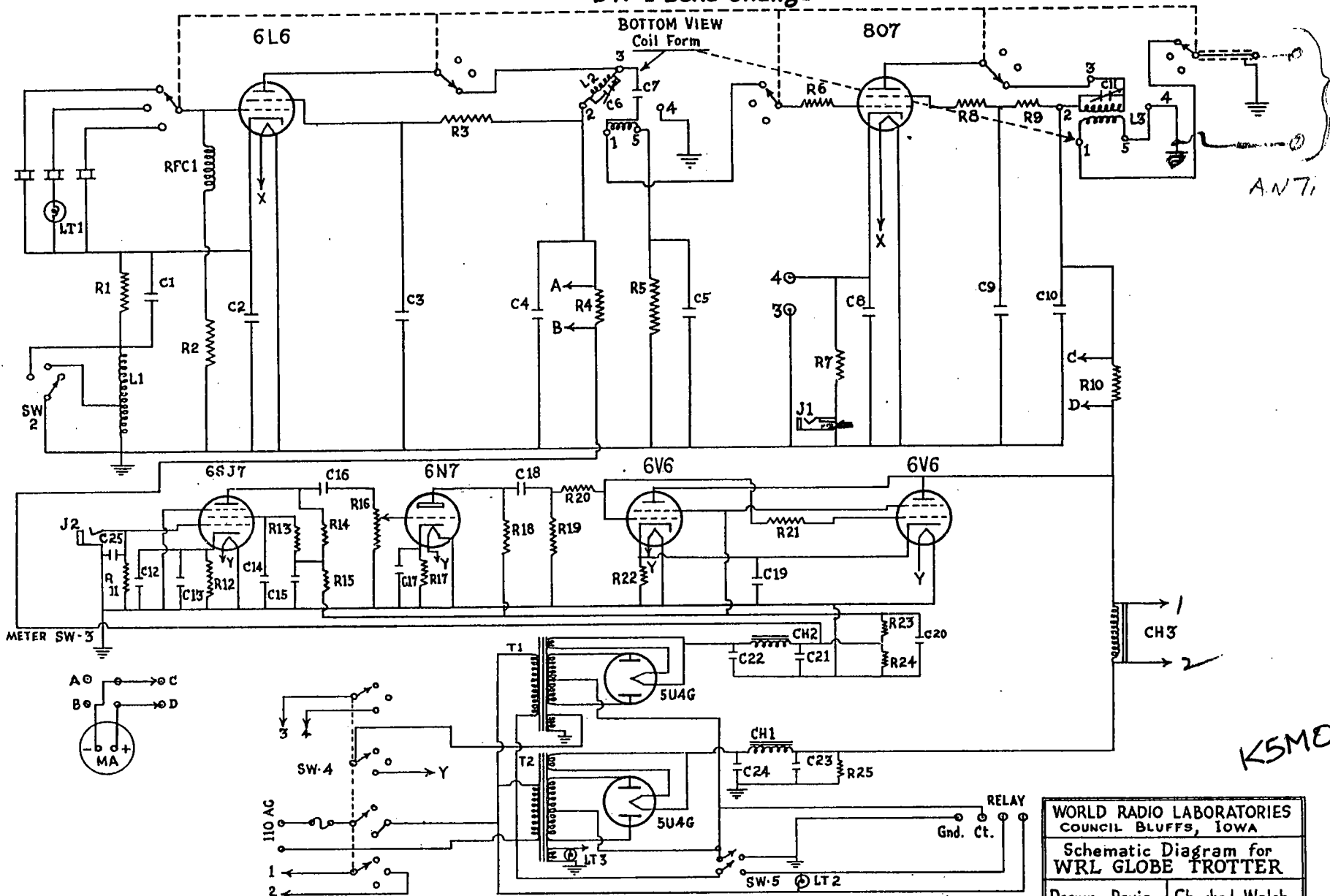

AN7i

K5MD

WORLD RADIO LABORATORIES
 COUNCIL BLUFFS, IOWA
 Schematic Diagram for
 WRL GLOBE TROTTER
 Drawn-Davis Checked-Welch
 Date 6-21-'46
 Redrawn-Murray Rechecked-DAVIS

GLOBE TROTTER PARTS LIST

1-chassis	3-16" pcs. shield mic cable
1-Panel	35-6/32 nuts and bolts
2-Side brackets	4-8/32 nuts
2-Power Transformers	6-solder gnd lugs
2-10H-150MA chokes	1-line cord and plug
1-10H-80MA choke	R1-lock- $\frac{1}{2}$ w
2-4mf-600V cond.	R2-lock-1w
2-2mf-600V cond.	R3, 9-10 Ohms-1w
1-Band switch & Bracket	R4, 5-47K-2w
1-off CW phone Switch	R6, 15k-1w
1-DPDT meter sw.	R7 & R22 -47 ohms 1 W.
2-110V Pilot lite assy.	R8, 21-7000 Ohms- 10w.
1-DPDT Transmit sw.	R10-2, 2M- $\frac{1}{2}$ w.
2-S6 bulbs	R11-2200- $\frac{1}{2}$ w.
2-closed ckt. jacks	R12-1.1M- $\frac{1}{2}$ w.
1-Gain Control	R13, 17-220K- $\frac{1}{2}$ w.
6-5 Prong bakelite sockets	R16-1500 Ohms- $\frac{1}{2}$ w.
9-Octal bakelite sockets	R14, 18-20K- $\frac{1}{2}$ w
1-Octal ceramic socket	R19-400K- $\frac{1}{2}$ w
1-110V. male receptacle	R20-200-10w
1-Fuse post & 3 amp fuse	CL-100 mmf
2-1" feed thru insulators	C2, 3, 6, 7, 8-.002mf-500V
1-4 screw terminal board	and C5
1-5 Prong ceramic socket and mounting plate	C4-15 mmf-500V
6-3 lug tie strips	C10, 14-10mf-50V
1-1 lug tie strip	C11-.1mf-400V
3-2 lug tie strips	C12, 15, 16, 18-10mf-450V Can Cond.
1-807 shield	C13, 17-.01mf-600V
2-Interstage shields	M-0-200MA
1-4/10 mf-450V cond.	J1-Key jack
2-Panel bearings	J2-Mic Jack
1-8" extension shaft	SW1-DPDT Toggle
1-3" extension shaft	RFC1, 2, 3, 4-2.5MH-125MA
2-Shaft Couplers	CH 1-10H-150MA
1-cathode sw.	Power Supply
1-807 plate cap	R1, 2-30K-20w
2-Harnessess	C1, 3-4mf 600V
3' #16 bus wire	C2, 4-2mf-600V
3' #18 solid covered wire	Ch 1-10H-80MA
3' #20 stranded covered wire	Ch 2-10H-150MA
4-Panel pillars	SW 1-DPST Transmit sw.
10-short rack screws	F51-3 Amp fuse
4-Short flat head pillar bolts	
2-Meter lugs	

GLOBE TROTTER COILS

K5MO

OSC.

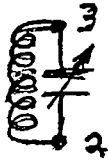

FINAL

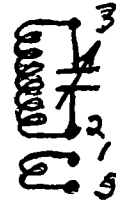

80 M	32 TURNS # 22 WIRE	LINK 4 TO 6 TURNS
40 M	14 TURNS # 20 WIRE	LINK 3 TO 5 TURNS
20 M	8 TURNS #20 WIRE	LINK 2 TO 4 TURNS
15 M	6 TURNS # 20 WIRE	LINK 2 TURNS
10 M	4 TURNS # 20 WIRE	LINK 2 TURNS
10 M	OSC. USE 20 M OSC. COIL	

80 AND 40 M ARE CLOSE WOUND
 20 15 10 SPREAD WINDING OVER 1 1/4 INCHES

80 M - 140 UFD
 40 M - 75 TO 100 UFD
 20 M - 50 UFD
 15 M - 35 UFD
 10 M - 25 UFD

***** USE HAMMARLUND APC CAPACITORS

USE 80 AND 40 M FUNDAMENTAL TYPE CRYSTALS