

Operating Instructions

for the

hallicrafters

HT Series Transmitters

Model HT 6



Manufactured By

the **hallicrafters** *co.*

Chicago, U. S. A.

94X073

OPERATING INSTRUCTIONS

MODEL HT6

25 Watt Telephone and Telegraph Transmitter

1. UNCRATING

Remove the transmitter and accessories from the crate and carefully inspect for possible damage during shipping. If any damage is found, file a claim immediately with the transportation company at your local office. It is recommended that the original packing material be preserved.

2. INSTALLATION

The transmitter may be connected to a source of 110 volts, 60 cycle AC power without further changes. Provision is made for use with other power supplies, and connections for such are shown in Figure 3 and Figure 4. Figure 3 shows connections which may be made to the rear plugs when it is desired to use an external 6 volt battery for filament supply and dynamos or vibrapack units for plate supply. The R.F. plate supply requires about 150 MA at 450 volts and the audio supply about 120 MA at 450 volts. Separate power supplies can be used for R.F. and audio or a single supply for both if connections are paralleled as shown in the diagram. Lower voltage supplies may be used accompanied by the decrease in output. In any case, 6 volts should be used for the filaments, the filament drain being about 3 amp. for the R.F. section and about 2 amp. for the audio section. The AC connections for audio and R.F. are brought out separately to the center plug in the rear of the transmitter. If vibrator or rotation type converters are used, not capable of supplying 240 watts to operate the entire transmitter, a 150 watt, 110 volt converter can be used to supply the R.F. through the regular cord and plug and a 110 watt, 110 volt converter can be connected to the two small prongs of the 4 prong plug to supply the audio. For CW operation no power supply need be connected to the audio section, of course.

Figure 2, illustrates the connections to the five terminal strip on the rear, including leads to the key and stand-by connection to the receiver (which is opened with the stand-by switch in the transmit position). The last two terminals are closed with the stand-by switch in the transmit position and may be used to operate an antenna relay if such is desired.

The two antenna terminals appear on the right hand side of the cabinet and may be used to connect to either a balanced transmission line or an antenna and ground system. The antenna terminals are automatically connected inside of the transmitter to the particular tank coil in use. For a discussion of antennas see Section 5.

3. COIL SETS AND TUNING PROCEDURE

(a) Location of Coils

Provision is made in the transmitter for setting up 3 complete frequencies, each one composed of one set of coils. A type 6L6 tube is used to drive the final amplifier and it has grid and cathode connections brought out to allow a variety of circuits. On the 4 lower amateur frequency bands the 6L6 is used as a separate crystal oscillator. The crystal may be replaced by a unit which converts the tube to an electron coupled oscillator. For ten meter operation the oscillator tube is converted to a triode type of oscillator by means of another plug-in unit.

For five meter operation provision is made for using the 6L6 as a doubler, plugging in a unit which includes a small separate triode crystal oscillator. Figure 1 shows the location of the sockets for the various coils, the numbers corresponding with the numbers appearing on the band switch control.

(b) Straight Crystal Operation

The coil sets for operation on 160, 80, 40 and 20 meter bands includes 3 units namely, the crystal adaptor, oscillator, tuning unit, and power amplifier tank coil. If, for example,

it is desired to set up band 1 to work on 20 meters, the crystal adaptor is plugged into position 1 and into it a 20 meter crystal such as a Bliley type HF2. The oscillator tuning can be plugged into position 1 as shown in the diagram and the power amplifier tank coil plugged into socket No. 1 in its respective location.

Tuning is done as follows:-

Place the meter switch to read PA grid, the plate switch in the center or 'off' position and the band switch in band 1 position. The key should be closed and the antenna disconnected. Turn on the AC power switch and, after allowing the filaments to warm up, close the stand-by switch. Rotate the knob on the top of the oscillator tuning unit until grid current is obtained. The grid current will probably be in the neighborhood of full scale deflection at its maximum position. The control should be backed off on the stable side of resonance until the grid current is in the neighborhood of 5 MA. (The stable side referred to is noticed as being the side where the grid current drops off slightly when detuning). Now place the meter switch in the PA plate position, turn the plate switch to the CW position and rotate the plate circuit tuning control until resonance is obtained as indicated by a minimum reading on the meter. The antenna may now be connected and the loading adjustment increased, starting with a small number of pickup coil turns until the resonant plate current is about 90 MA. At this point the transmitter will be delivering between 25 and 30 watts of output.

For 40 meter operation, a Bliley B5 40 meter crystal is recommended, and for 80 meter and 160 meter operation, Bliley types LD2 80 and 160 meter crystals are recommended.

(c) Electron Coupled Operation

The electron coupled units merely replace the crystal adaptor in the corresponding coil set as listed above. The knob at the top will vary the frequency over the amateur band indicated and extend slightly on either side. No attempt has been made to calibrate the unit in frequency, the setting being made with the use of an accompanying receiver or frequency monitor. After the correct frequency has been obtained the oscillator plate tuning is adjusted for proper grid current and the final amplifier tuned as before. The ECO oscillator circuit is operated at one-half the output frequency of the transmitter for best stability. Tuning the oscillator plate control through resonance will vary the frequency by a small amount of the order of one to four KC, depending on which coil is being used, but henceforth the frequency will be stable. The oscillator padding condenser is of the negative temperature coefficient type adjusted so that after the initial warming up period is past the frequency drift with temperature will be very slight. The amateur is cautioned to observe his frequency very carefully in using this type of oscillator. Unless a very accurate frequency meter is available he should not attempt to operate close to the edge of an amateur band.

(d) Ten Meter Coil Set

The 10 meter coil set is similar to the lower frequency crystal and coil sets except that a 20 meter crystal is used and plugged into the top of the tritet unit, which in turn plugs into the corresponding crystal position. The knob on the rear of the can tunes the crystal to resonance which will indicate as a rise in oscillator plate current. The oscillator plate tuning knob should be adjusted for correct grid current reading and the final tank tuned as before.

(e) Five Meter Coil Set

In order to reduce losses, provision has been made for using the 5 meter coil set in band 1 position only. The crystal oscillator unit plugs into the two adjacent sockets as shown in Figure 1. All circuits are switched with the exception of the final tank. When it is desired to use 5 meters the small thumb screw on the rear of the tank tuning condenser is loosened and the flexible connection to the chassis insulator is removed. The 5 meter tank coil is fastened directly on top of the tuning condenser by a thumb nut and the thumb screw into the front plate of the condenser frame. A single turn antenna link is plugged into the tank coil socket No. 1 and the antenna coupling adjusted by bending the link slightly. This link must be coupled to the front or 'cold' end of the tank coil. The oscillator tuning knob is adjusted after the rise in oscillator plate current and the oscillator plate tuning adjusted for maximum grid current. Tuning of the antenna is done in the same manner as previously described. A 10 meter crystal similar to the Bliley type HF2 is used.

4. OPERATION

(a) CW Operation

With the transmitter tuned up as in Section 3 and with the audio gain in the 'off' position, CW operation is effected by keying the transmitter with the plate switch in the CW position. Change from send to receive is effected by the stand-by switch.

(b) Phone Operation

The microphone used should be of the high impedance type such as a diaphragm crystal microphone. If low impedance microphones are used a step-up transformer should be connected externally to the transmitter. The microphone leads are brought in with a shielded wire through the top of the input can and connected to the screwed terminals inside the can. The outer conductor or shield is connected to the grounded terminal and the inner conductor to the ungrounded terminal which is connected to the R.F. choke. The plate switch is set in the phone position and the audio gain control turned on and advanced until sufficient modulation is obtained. The audio gain is ample for most microphones and it will be found that with a diaphragm crystal microphone the proper setting of the main control will be at about 8. Modulation will be indicated by a 10 MA rise in modulation plate current reading on modulation peaks. During phone operation the keying leads should be closed and control of transmission is secured by the transmit stand-by switch.

5. ANTENNA RECOMMENDATIONS

General

For antenna connection a separate pickup coil is provided on each plate coil. Connections to the pickup coils are made by means of flexible leads which may be soldered to the tinned winding so as to include any desired number of fractional turns.

Hence, when the output coils are adjusted for the particular antenna used with the transmitter no further adjustment is necessary when changing bands.

Since the portion of the pickup coil in use is quite closely coupled to the plate coil at all times and the L/C ratio of the plate is never so great as to require an excessively high impedance to be reflected into the plate coil to obtain the proper plate loading, satisfactory coupling may be obtained into resistive loads varying from low resistance Marconi or doublet antennas to high resistance loads presented by matched-impedance single-wire fed antennas. No provision is made in the transmitter to tune antennas which are not of the proper dimensions for the frequency used and therefore present a reactive load. If the antenna used requires inductive or capacitive loading to tune to the operating frequency, this must be done with an external coil or condenser. The winding of the pickup coil, because of its close coupling to the tank coil, cannot be used as an inductive loading coil, but only as a coupling coil, in accordance with the best practice for obtaining stable loading and maximum harmonic attenuation.

The problem of providing a suitable antenna installation must, of course, be solved by the operator with due consideration to the space and facilities available, and the frequency bands to be used. For those not acquainted with this subject, a study of the chapter on antennas in the 'Radio Amateur's Handbook' published by the American Radio Relay League, Inc., West Hartford, Conn., is highly recommended. Of the many types of antennas available, those most desirable from a standpoint of efficiency of power transfer, minimum radiation from feeders, and simplicity of coupling arrangements are the Johnson 'O', two-wire fed matched-impedance 'Y' type, matched-impedance single wire fed, and twisted-pair doublet. The efficiency of twisted-pair feeders is rather low at frequencies higher than that of the 40 meter amateur band.

All of the antennas listed above have the disadvantage of being designed for operation at only a single frequency, except that the single-wire fed antenna operates fairly satisfactorily at multiples of its fundamental frequency. Any of these antennas, may, of course, be used as a simple Marconi operated against ground at the lower frequencies.

Matched-Impedance Antennas

These include the two-wire matched-impedance antennas such as the Johnson 'O', 'Y' and twisted-pair fed doublet, and the single-wire fed matched impedance antennas. The antenna coupling procedure for these antennas is first, connect the two antenna feeders to the antenna terminals on the insulator at the side of the cabinet. In the case of the single-wire fed antenna, connect one antenna terminal to a good ground connection. Second, connect the flexible leads to the pickup coil so as to include approximately the number of turns between connections given in the table below:

<u>Amateur Band</u>	<u>No. of Turns</u>
160 Meters	10
80 '	8
40 '	6
20 '	4
10 '	2

Third, turn on the plate voltage, press the key and tune the plate tuning condenser for minimum plate current. If the antenna is cut to the proper length for the frequency and particular local condition surrounding the antenna, and if the degree of coupling is correct, this minimum plate current will be 90 MA, and the plate condenser setting will be very nearly the same as that noted previously when tuning the plate circuit to resonance without the antenna connected. If the plate current is too low, increase the number of turns in the pickup coil; if the number of turns in the pickup coil is too great, the plate current will rise to some value in excess of 150 MA, and no resonant indication will be noticed. If the amplifier tuning dial reading at resonance with the antenna coupled differs from that noted without the antenna coupled by more than approximately ten degrees of rotation the antenna is not of the proper dimensions for the frequency used and is presenting a reactive load to the transmitter. Operating under this condition will be at somewhat reduced efficiency.

Marconi Antennas

A single wire, approximately one quarter wave long from transmitter to far end, or one of the antennas described above, designed for operation at a higher frequency but used as a simple 'T' antenna, may be used as a Marconi antenna. Such an antenna should be connected in series with an external loading coil and variable condenser on antenna terminal. The other should be connected to a good ground connection, such as a clamp or cold water pipe main, near the spot at which the main enters the basement of the house. If the antenna is approximately one quarter wave long, the loading coil may be of about the same dimensions as the plate coil but with somewhat fewer turns. The antenna tuning condenser should have a capacity of about 200 mmfd., but may be of the ordinary receiving type. If the antenna is shorter than one quarter wave length, the number of turns in the loading coil must be increased to obtain resonance in the antenna circuit. The number of turns required in the pickup coil for use with a Marconi antenna will be less than that given in the table above. Starting with comparatively few turns in the pickup coil, the plate tuning condenser is first set at the no-load resonance setting previously noted. The antenna tuning condenser and, if necessary, the inductance of the external loading coil are then varied until resonance is obtained in the antenna circuit as evidenced by an increase in plate current at the resonant setting. The number of turns in the pickup coil is then adjusted and the antenna retuned until the proper plate loading is obtained. As a final check the plate condenser is then retuned for a minimum plate current. If the setting so found is different from the no-load resonance setting, the antenna circuit is not in tune and the number of turns on the pickup coil is too great.

Other Antennas

Other antennas, such as the Zeppelin, tuned doublet, etc., may be coupled and tuned somewhat as described above for the Marconi antenna by using two antenna tuning condensers, two external loading coils, and series or parallel tuning, as required. However, a much more convenient arrangement consists of two variable condensers, a tapped coil, and a switch for connecting the condensers in series or parallel with the coil as required. The coil is then link coupled to the amplifier plate coil, using one or two turns of the pickup coil as the coupling link at the transmitter. A 'pi' network may also be used as a variable antenna

coupling device by connecting the input terminals of the network to the antenna terminals of the transmitter and using all of the turns in the pickup coil. The 'multi-band' antenna is a variation of the tuned doublet, in which the transmission line impedance is about the mean of the terminating impedance, resulting in a minimum mis-match and loss. If properly cut to length, it may be used on several harmonic frequencies by coupling directly to the pickup coil.

Dimensions and details are given on page 307 of the Radio Amateur Handbook for 1938. Where the copper tuning feeders prove unwieldy, very nearly as good results may be obtained by replacing them with feeders consisting of two #10 wires spaced 1 1/2' to 2', giving a transmission line impedance of about 400 ohms.

In any antenna, tuning system, especially where no external tuning is used, a careful check should be made by the amateur to see that harmonic radiation is at a minimum. Harmonic radiation is apt to be serious when the antenna, not carefully cut to length, causes considerable detuning of the tank condenser.

6. NORMAL METER READINGS

Full Load conditions

Oscillator plate - 25 ma (70 MA on 5 meters)	P.A. plate - 90 MA
P.A. grid - 2 to 5 MA	Mod. plate - 100 to 125 MA on mod. peaks

7. TEST VOLTAGES

(With 1000 ohms per volt meter)

Full Load

5Z3 Fil	- 5.0V. AC
All Other Fils	- 6.3 V. AC
6L6G Plate	- 480 V.
6L6 Screen	- 350 V.
6L6 Cathode	- 30 V.
6J5 Plate	- 215 V.
6J5 Cathode	- 6 V.
6F5 Plate	- 75 V.
6F5 Cathode	- 1 V.

Full Load

RK39 Plate	- 500 V.
RK39 Screen	- 330 V.
RK39 Cathode	- 19 V.
RK39 Grid	- 17 V.
6L6 Plate	- 500 V.
6L6 Screen	- 25 V. to 250 V.
6L6 Cathode	- 5 V.
6L6 Grid	- 30 V.

GUARANTEE

This transmitter is guaranteed to be free from any defect in workmanship and material that may develop within a period of ninety (90) days from date of purchase, under the terms of the standard guarantee, as designed by the Radio Manufacturers Association. Any part or parts that prove defective within this period will be replaced without charge when subjected to examination at our factory, providing such defect, in our opinion, is due to faulty material or workmanship, and not caused by tampering, abuse or normal wear. All such adjustments to be made FOB the factory.

Should it be necessary to return any part or parts to the factory, a 'Return Material Permit' must be obtained in advance by first writing the Adjustment Department, who will issue due authorization under the terms of the guarantee. The Hallicrafters Co., reserve the right to make changes in design or add improvements to instruments manufactured by them without incurring any obligation to install the same in any instrument purchased.

All Hallicrafters transmitters are built under Patents of Radio Corporation of America and the American Telephone and Telegraph Company.

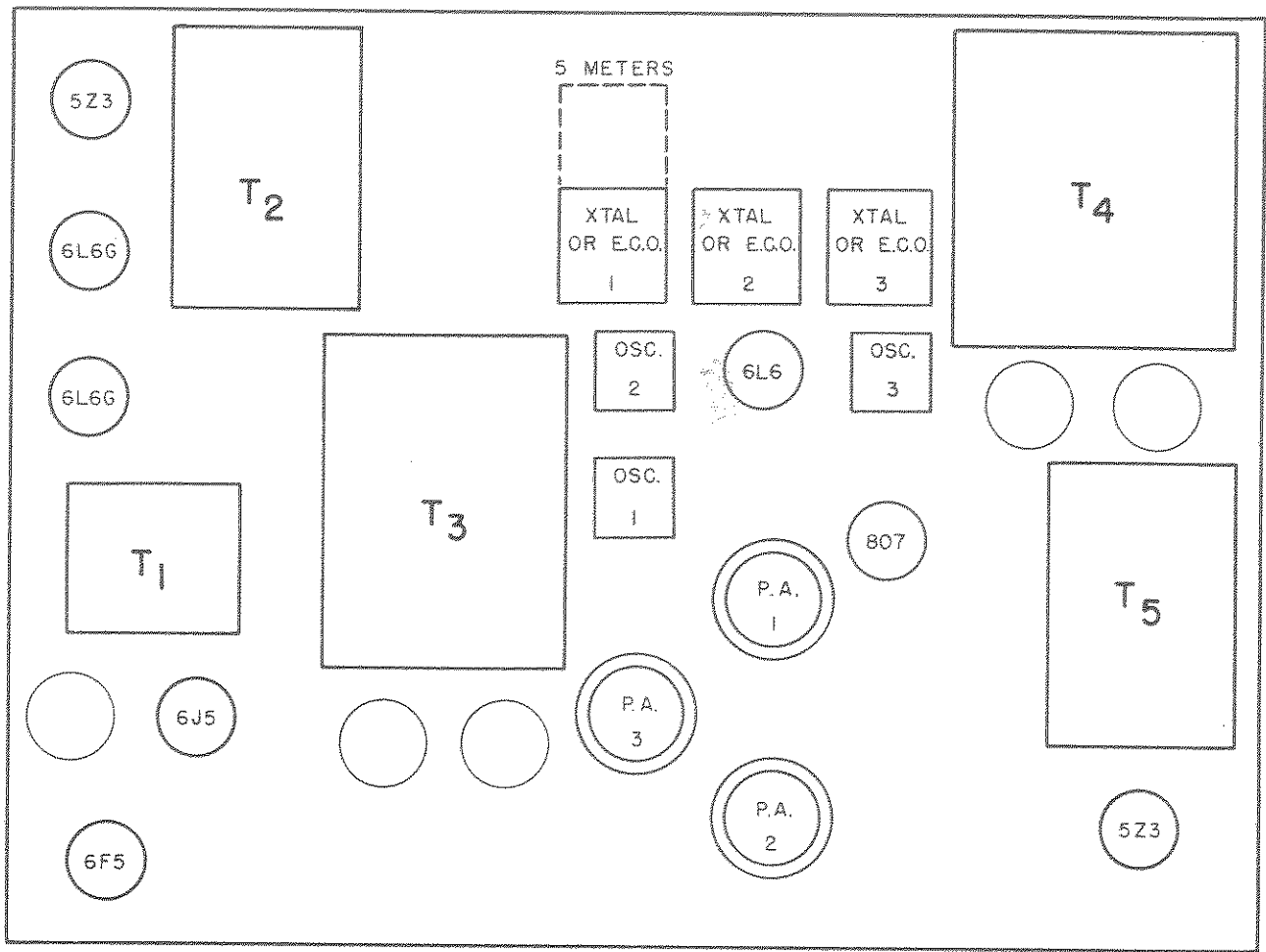

Fig. 1

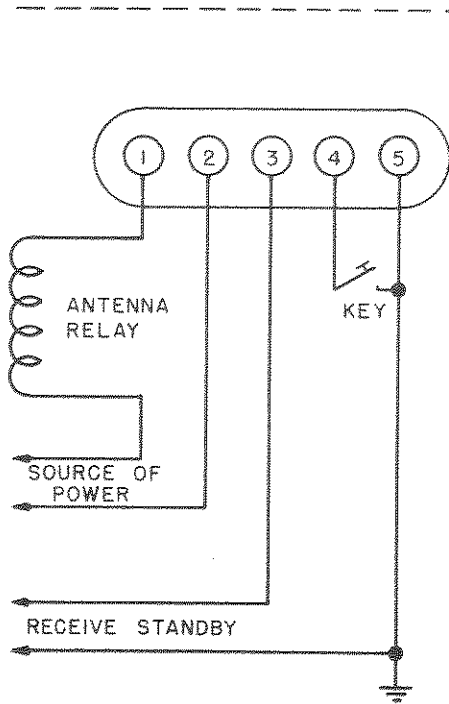

Fig. 2

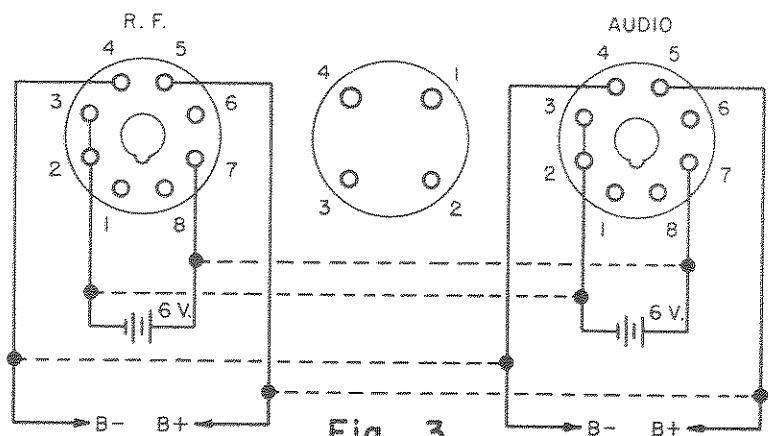

Fig. 3

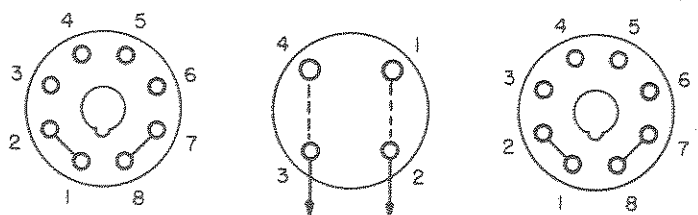

Fig. 4

TO 110 V. A.C.
FOR MODULATOR

HT-6 COIL SETS FOR 1.75-3.5-7-14 & 28 MC.

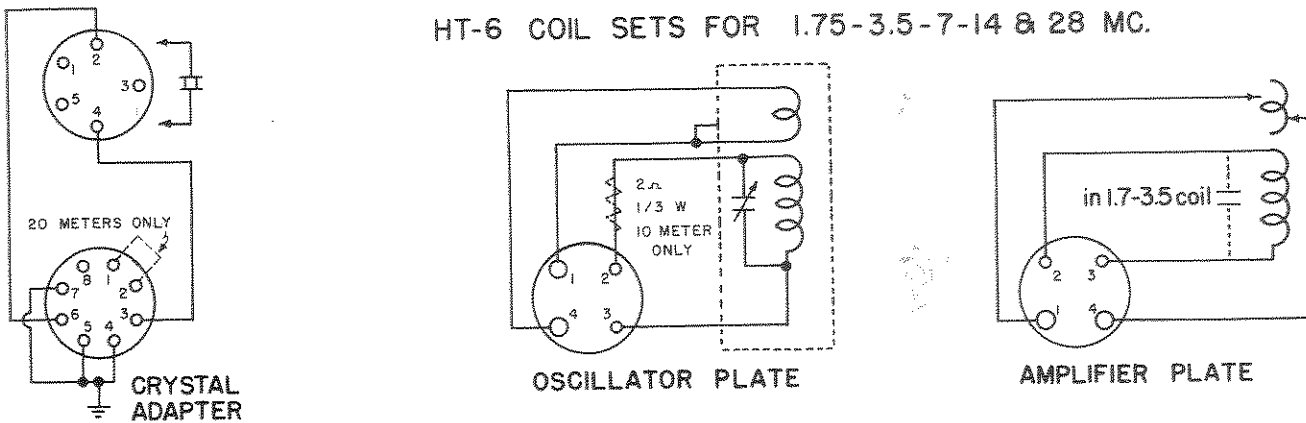

Fig. 5

E.C.O. UNIT FOR 1.75 TO 14 MC.

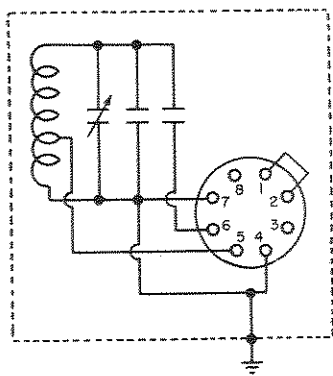

Fig. 6

TRI-TET OSCILLATOR UNIT FOR 28 MC.

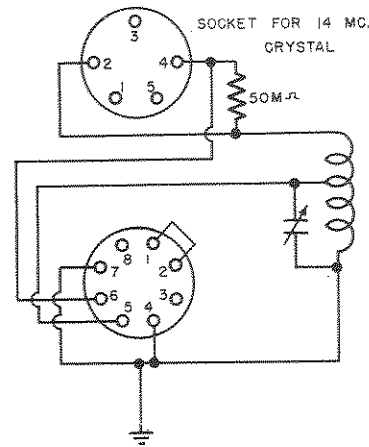
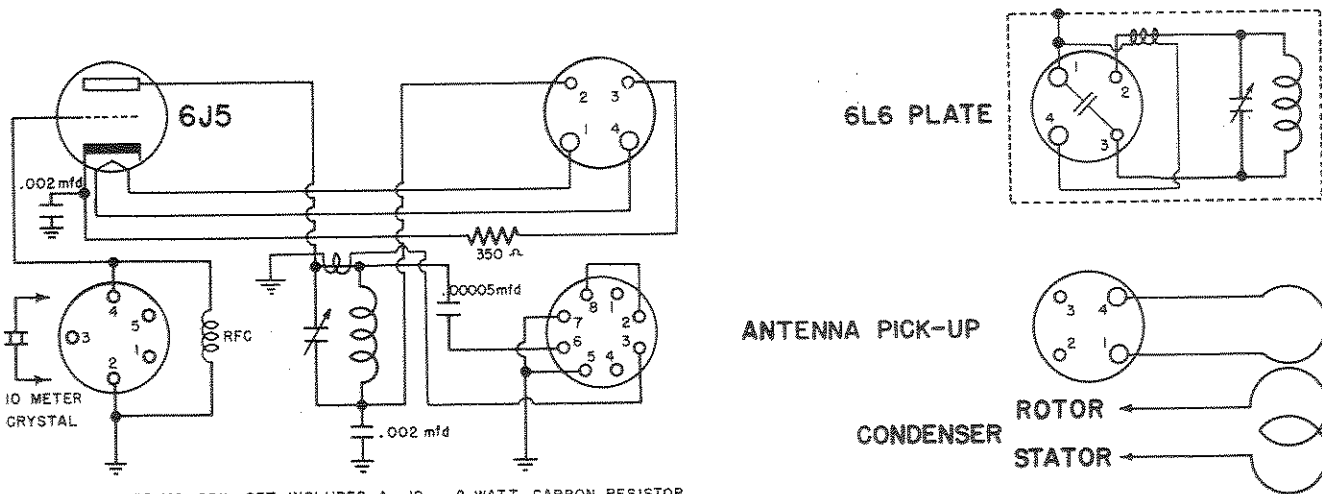

Fig. 7

COIL SET FOR 56 MC - Fig. 8



NOTE: - 56 MC. COIL SET INCLUDES A 10 Ω 2 WATT CARBON RESISTOR TO REPLACE THE WIRE WOUND RESISTOR IN THE PLATE LEAD OF THE 6L6 TUBE

HT-6 RADIO TRANSMITTER

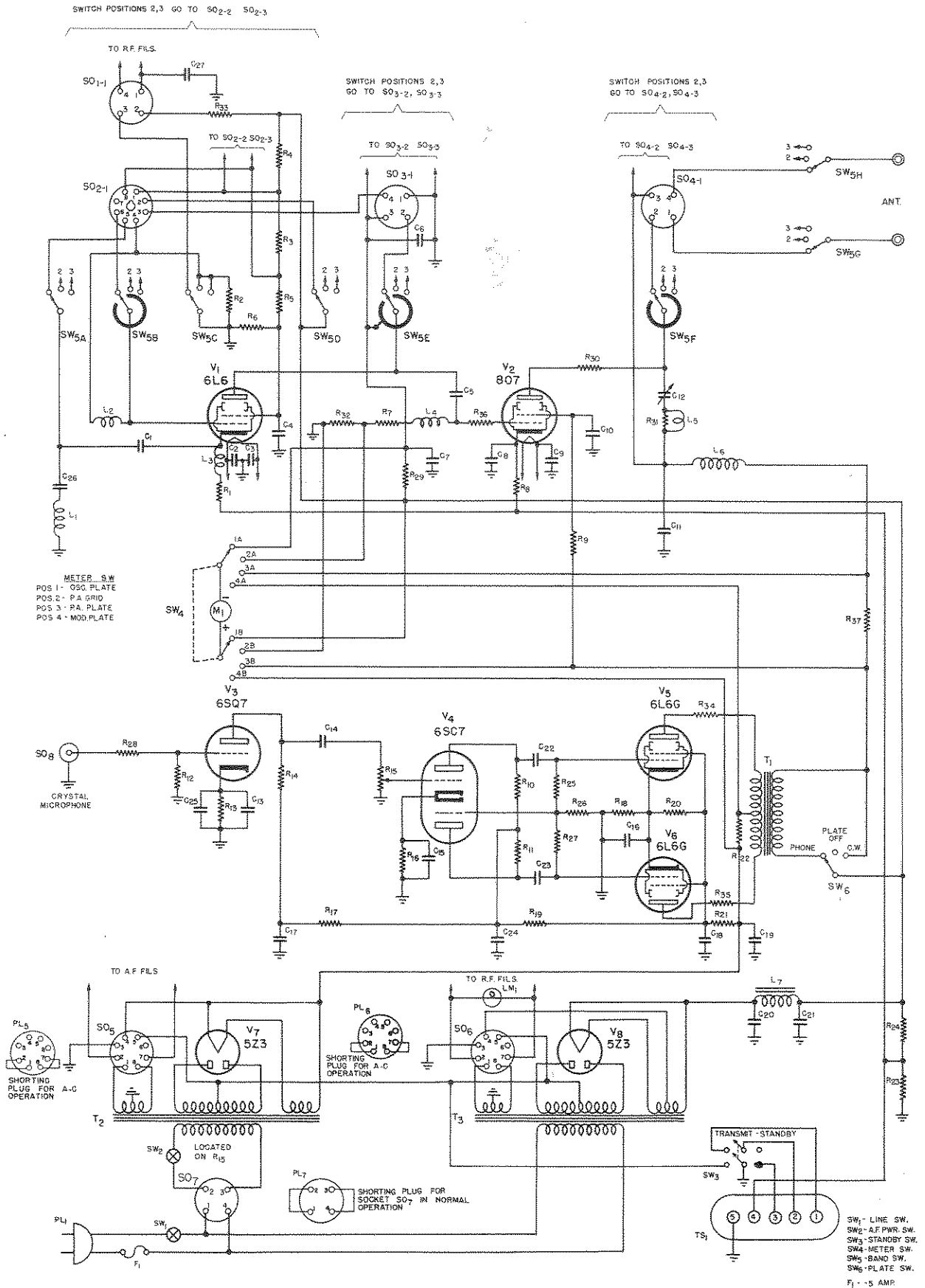

8. LIST OF REPLACEABLE PARTS

REF. SYMBOL	NAME OF PART AND DESCRIPTION	FUNCTION	MFR. CODE	CONTRACTORS PART NO.
R1	Resistor, 400 ohm \pm 1%, 2 watt, wire wound, type BW-2	Cathode bias for tube V ₁	IRC	24BV401E
R2	Resistor, 20,000 ohm \pm 5%, 1/2 watt, carbon	Grid return for tube V ₁	ASA	RC21AE203J
R3	Resistor, 30,000 ohm \pm 10%, 1 watt, carbon	Voltage divider for tube V ₁	ASA	RC31AE393K
R4	Resistor, 150,000 ohm \pm 10%, 1 watt, carbon	Voltage divider for tube V ₁	ASA	RC31AE154K
R5	Resistor, 10,000 ohm \pm 20%, 10 watt, wire wound, type CC; same as R ₆	Voltage divider for tube V ₁	U	24BG103F
R6	Same as R ₅	Voltage divider for tube V ₁	ASA	RC41AE113J
R7	Resistor, 11,000 ohm \pm 5%, 2 watt, carbon	Grid return for tube V ₂	U	24BG201F
R8	Resistor, 200 ohm \pm 20%, 10 watt, wire wound, type CC	Cathode bias for tube V ₂	U	24BG213F
R9	Resistor, 20,000 ohm \pm 20%, 10 watt, wire wound, type CC	Screen voltage reducer	ASA	RC21AE104K
R10	Resistor, 100,000 ohm \pm 10%, 1/2 watt, carbon; same as R ₁₁	Plate load for part of tube V ₄	ASA	RC21AE104K
R11	Same as R ₁₀	Plate load for part of tube V ₄	ASA	RC21AE104K
R12	Resistor, 1.8 megohm \pm 10%, 1/2 watt, carbon	Grid return for tube V ₃	ASA	RC21AE185K
R13	Resistor, 2,400 ohm \pm 10%, 1/2 watt, carbon	Cathode bias for tube V ₃	ASA	RC21AE242K
R14	Resistor, 220,000 ohm \pm 10%, 1/2 watt, carbon; same as R ₂₅ , R ₂₆ , R ₂₇	Plate load for tube V ₃	ASA	RC21AE224K
R15	Resistor, variable, 500,000 ohm \pm 20%, carbon, type L25	AUDIO GAIN control	CT	25C031
F16	Resistor, 1,000 ohm \pm 10%, 1/2 watt, carbon	Cathode bias for tube V ₄	ASA	RC21AE102K
R17	Resistor, 47,000 ohm \pm 10%, 1/2 watt, carbon	Decoupling for tube V ₃	ASA	RC31AE473K
R18	Resistor, 250 ohm \pm 10%, 10 watt, wire wound, type CC	Cathode bias for tubes V ₅ and V ₆	U	24BG251E
R19	Resistor, 20,000 ohm \pm 5%, 2 watt, carbon	Decoupling for tubes V ₃ and V ₄	ASA	RC41AE203J
R20	Resistor, 20,000 ohm \pm 10%, 20 watt, wire wound, type CC	Voltage divider for V ₅ and V ₆	U	24B1203E
R21	Resistor, 5,000 ohm \pm 20%, 10 watt, wire wound, type CC	Voltage divider for tubes V ₃ , V ₄ , V ₅ , and V ₆	U	24BG502F
K22	Resistor, 9,367 ohm, wire wound, 200 milliamper meter shunt for Beede meter #701,10 milliamper movement, special	Meter shunt	O	24A833
R23	Resistor, 2,500 ohm \pm 20%, 10 watt, wire wound, type CC	R.F. power supply bleeder	U	24BG252F
R24	Resistor, 40,000 ohm \pm 20%, 20 watt, wire wound, type CC	R.F. power supply bleeder	U	24B7403F
R25	Same as R ₁₄	Grid return for tube V ₅		
R26	Same as R ₁₄	Grid return for tubes V ₄ , V ₅ , and V ₆		
R27	Same as R ₁₄	Grid return for tube V ₆		
R28	Resistor, 22,000 ohm \pm 10%, 1/2 watt, carbon	Parasitic suppressor for tube V ₃	ASA	RC21AE223K
R29	Same as R ₂₂	Meter shunt		
R30	Resistor, 10 ohm \pm 10%, 2 watt, wire wound, type BW-2	Parasitic suppressor for tube V ₂	IRC	24BV100E
R31	Resistor, 33 ohm \pm 10%, 1/2 watt, wire wound	Parasitic suppressor for tube V ₂	ASA	RC21AE330K
R32	Resistor, 150 ohm \pm 10%, 1/2 watt, wire wound, type BR-1/2	Grid return for tube V ₂	IRC	24BX101F
R33	Resistor, 27,000 ohm \pm 10%, 2 watt, carbon	Plate voltage reducer	ASA	RC41AE273K

R34	Resistor, 33 ohm \pm 10%, 1/2 watt, carbon; same as R35	Parasitic suppressor for tube V ₅	RC21AE330K
R35	Same as R34	Parasitic suppressor for tube V ₆	RC21AE100K
R36	Resistor, 10 ohm \pm 10%, 1/2 watt, carbon	Parasitic suppressor for tube V ₂	ASA
R37	Same as R22	Meter shunt	ASA
C1	Capacitor, 1800 mmfd, \pm 10%, 500 V.D-C working, mica dielectric; same as C ₂ , C ₃ , C ₄ , C ₆ , C ₇ , C ₉ , C ₁₀ , C ₂₅ , C ₂₆	Cathode coupling for tube V ₁	CM30A182K
C2	Same as C ₁	R-f by pass for filament of tube V ₁	
C3	Same as C ₁	R-f by pass for filament of tube V ₁	
C4	Same as C ₁	Screen filter for tube V ₁	
C5	Capacitor, 56 mmfd, \pm 10%, 500 V.D-C working, mica dielectric	Coupling between tubes V ₁ and V ₂	CM25A560K
C6	Same as C ₁	Plate return for tube V ₁	
C7	Same as C ₁	R-f by pass for meter shunt R ₂₉	ASA
C8	Capacitor, 5600 mmfd, \pm 10%, 500 V.D-C working, mica dielectric	Cathode by pass for tube V ₂	CM35A562K
C9	Same as C ₁	Filament by pass for tube V ₂	
C10	Same as C ₁	Screen filter for tube V ₂	ASA
C11	Capacitor, 2200 mmfd, \pm 10%, 2500 V.D-C working, mica dielectric	Plate return for tube V ₂	CM50A222K
C12	Capacitor, variable, min. cap. 9 mmfd., max. cap. 106 mmfd., single section, air dielectric, type 100F20	Resonating capacitor for R-F amplifier tank circuit	JO
C13	Capacitor, 10 mfd, +65% - 10%, 25 V.D-C, Electrolytic, type P R 25; same as C ₁₅ , C ₁₆	Low frequency by pass for tube V ₃	A
C14	Capacitor, 20,000 mmfd, -10 + 65%, 25 V.D-C working paper dielectric, special	Coupling between tube V ₃ and V ₄	A
C15	Same as C ₁₃	Cathode by pass for tube V ₄	
C16	Same as C ₁₃	Cathode by pass for tubes V ₅ and V ₆	
C17	Capacitor, 4 mfd, -10 +50%, 475 V.D-C working, electrolytic, one part of dual unit; refer to C ₂₄ ; type EP-MO4	Plate return for tube V ₃	A
C18	Capacitor, 8 mfd, -10 + 50%, 600 V.D-C working, electrolytic, type EP-MO4; same as C ₁₉ , C ₂₀ , C ₂₁	Screen filter for tubes V ₅ and V ₆	A
C19	Same as C ₁₈	High voltage filter for a-f power supply	
C20	Same as C ₁₈	High voltage filter for r-f power supply	
C21	Same as C ₁₈	High voltage filter for r-f power supply	
C22	Capacitor, 0.05 mfd, -10 + 40%, 600 V.D-C, paper dielectric, special; same as C ₂₃	Coupling between tube V ₅ and part of tube V ₄	SP

LIST OF REPLACEABLE PARTS

REF. SYMBOL	NAME OF PART AND DESCRIPTION	FUNCTION	MFR. CODE	CONTRACTORS PART NO.
C23	Same as C22	Coupling between tube V ₆ and part of tube V ₄		
C24	Capacitor, same as C ₁₇ - one unit of dual unit	Plate return for tube V ₄		
C25	Same as C ₁	R-F by pass in Cathode circuit of tube V ₃		
C26	Capacitor, 27 mmfd. ± 10%, 500 V.D-C working, mica dielectric	Cathode return by pass for tube V ₁	ASA	CM20A270K
C27	Same as C ₁	R-F by pass in filament circuit of 501.1		
T1	Transformer, modulator, primary to match push pull 6L6G secondary to match 4,000 ohm Class 'C' load. Secondary winding current 105 milliamperes D-6 max; type 10A15	Audio frequency coupling between modulator tubes V ₅ and V ₆ and class C power amplifier tube V ₂	ST	55A050
T2	Transformer, Power, A-F, primary 117 V.A-C, single phase, 50.60 cycles; secondary, 400 V, each side of center tap / 6.3 V.A-C @ 2.4 amperes, center tapped / 5 volts @ 3 amperes; type 10P31	Filament and high voltage supply for audio frequency amplifier tubes V ₃ , V ₄ , V ₅ , and V ₆	ST	52B066
T3	Transformer, Power, R-F, Primary 117 volts A-C, single phase, secondary 450 volts each side of center tap; 6.3 volts @ 2 amperes center tapped, 5 volts @ 3 amperes, center tapped; type 10P30	Filament and high voltage supply for radio frequency amplifier tubes V ₁ and V ₂	ST	52B067
L1	Reactor, 2-1/2 turns of #18 A.W.G. wire, air core	R-f impedance in Cathode circuit of tube V ₁	H	
L2	Reactor, R-F, 1 millihenry + 3% inductance, 20 ohms + 20% d-c resistance, 3.5 mmfd. + 50% distributed capacity, 4 pi universal winding on ceramic dowel, type 4885; same as L ₃ , L ₄ , L ₆	R-f impedance in grid circuit of tube V ₁	GU	51A134
L3	Same as L ₂	R-f impedance in cathode circuit of tube V ₁		
L4	Same as L ₂	R-f impedance in grid circuit of tube V ₂		
L5	Reactor, 1/2 turn of #14 A W G wire, air core	R-f impedance across parasitic suppressor R ₃₁	H	
L6	Same as L ₂	R-f impedance in plate circuit of tube V ₂		

L7	Reactor, filter choke, 6 henry + 10% inductance, 250 milliamperes D-C current rating, 125 ohms + 10% d-c resistance, iron core, wax impregnated winding and terminal panel, type 10C13	R-f power supply filter reactor	ST	56B018
SW1	Switch, toggle, DPDT, current rating 3 amperes @ 250 V., mounts by 15/32-32x3/4" bushing, type 81012	Line switch	HH	60A127
SW2	Switch, toggle action, mounted on back plate of audio frequency gain control	A-C switch for audio frequency amplifier power supply		
SW3	Switch, toggle, D.P.D.T. current rating 3 amperes @ 250V., mounts by 15/32 x 13/32" bushing, type 8363	TRANSMIT - STANDBY switch	CH	60A090
SW4	Switch, rotary selector, 4 position, 1 section, low loss bakelite wafer, non-shorting contacts, special	Meter switch	OM	60B026
SW5A 5B 5C 5D 5E 5F 5G 5H SW6	Switch, rotary selector, 3 position, 1 section, low loss bakelite wafer, shorting type contacts, type H special	BAND SWITCH	OM	60B047
TS1	Switch, rotary selector, 3 position, 1 section, low loss bakelite wafer, shorting type contacts, type 12-2882	C.W.-Phone switch	CRL	60E025
SO1	Terminal strip, 5 screw type terminals numbered 1 to 5 (white filled) 2 hole mtg. type 5-50	Connector for external control	HJ	88A074
SO2-1 SO2-2 SO2-3	Socket, octal, low loss mica filled bakelite, ring mtg. type, unmarked, type SST	Tuning unit socket for grid circuit of V1 on 56MC	AP	6A194
SO3	Socket, octal, body low loss mica-filled bakelite, steel mtg. plate with 1-1/2" mtr. centers molded to body, type M1P8T	Tuning unit socket for grid circuit of oscillated tube V1	AP	6A019
SO4	Socket, 4 prong, bakelite, steel mtg. plate with 1-1/2" mtg. centers molded to body, unmarked, type M1P4T; same as SO4	Tuning unit socket for plate circuit of oscillator tube V1	AP	6A142
	Same as SO3	Antenna pickup coil socket		

LIST OF REPLACEABLE PARTS

REF. SYMBOI	NAME OF PART AND DESCRIPTION	FUNCTION	MFR. CODE	CONTRACTORS PART NO.
SO ₅	Socket, octal, body-high dielectric black bakelite, ring type mtg., type S ₈ ; same as SO ₆	A-c filament connection for a-f tubes V ₃ , V ₄ , V ₅ , and V ₆	AP	6A177
SO ₆	Same as SO ₅	A-c filament connection for r-f tubes V ₁ and V ₂		
SO ₇	Socket, 4 prong, bakelite supplied with #4 retainer ring, unmarked, type S ₄	Aux. converter power connection	AP	6A189
SO ₈	Connector, sh. sided, shorting type, mounted by 3-8-24 x 11-32 bushing with mtg. hardware, connector section 5-8-27-N27-2 thread, type CLFC1M	Microphone connection to pre-amplifier stage	AP	29A043
PI ₁	Plug and line cord assembly, 2 conductor, all rubber covered, length 6 feet with spring type moulded on plug, type 1750	A-c line connection	B	87A078
PI ₅	Plug, octal, male, bakelite insulation, key guide, insulated jumpers connect terminals 1 and 2, 7 and 8, type CP-8 modified; same as PL ₆	Shorting plug for socket SO ₅	AP	35A011
PL ₆ PL ₇	Same as PL ₅ Plug, 4 prong, male, bakelite insulation, insulated jumpers connect terminals 1 and 2, 3 and 4, type CP ₄ modified	Shorting plug for socket SO ₆ Shorting plug for socket SO ₇	AP	10A113
F ₁	Fuse, 10 ampere @ 25 V., 3 AG, type 1081	Main line fuse	IF	39A316
M ₁	Meter, D.C. milliammeter, range 0 to 200 milliamperes D-C + 2%, round 3 mtg. hole on 1.7 16' radius escutcheon, type 701	OSC. PLATE, P.A. GRID, P.A. PLATE MOD. PLATE, current meter	B	82A048
LM ₁ V ₁ V ₂ V ₃	Lamp, 6.3V, 250 milliamperes, bayonet base, type H ₄ Tube, beam power amplifier, metal, type 616 Tube, triode amplifier, type 807 Tube, duplex-diode, high- μ triode, metal, type 6SO7	Tuning dial illumination Oscillator for exciter section Final class C 2-f Microphone amplifier for modulator section	GE ECA RCA RCA	39A003 90X616 90X807 90X6S07
V ₄ V ₅ V ₆ V ₇ V ₈	Tube, twin triode amplifier, metal, type 6SC7 Tube, beam power amplifier, glass, type 616G; same as V ₆ Same as V ₅ Tube, full-wave high-vacuum rectifier, type 5Z3; same as V ₈ Same as V ₇	Driver for modulator tubes V ₅ and V ₆ Modulator power amplifier Modulator power amplifier Rectifier for modulator section Rectifier for exciter and final 2-f amplifier section	RCA RCA RCA	90X6SC7 90X6L6G 90X5Z3

9. INDEX OF MANUFACTURERS

<u>SYMBOL</u>	<u>MANUFACTURER</u>	<u>SYMBOL</u>	<u>MANUFACTURER</u>
A	Aerovox Corp. New Bedford, Mass.	HH	Hart and Hegeman Electric Co. Hartford, Conn.
AP	American Phenolic Corp. Cicero, Illinois	HJ	Howard B. Jones Co. Chicago, Illinois
ASA	Any manufacturer meeting the applicable American Standard Association specification	IRC	International Resistance Co. Philadelphia, Pa.
BE	Beede Electrical Inst. Co. Penacook, N.H.	JO	E.F. Johnson Co. Waseca, Minn.
CH	Cutler-Hammer Inc. Milwaukee, Wis.	LF	Littlefuse Inc. Chicago, Illinois
CRL	Centralab Milwaukee, Wis.	O	Ohmite Mfg. Co. Chicago, Illinois
CT	Chicago Telephone Supply Co. Chicago, Illinois	OM	Oak Mfg. Co. Chicago, Illinois
E	Essex Wire Co. Chicago, Illinois	RCA	RCA Manufacturing Co. Camden N.J.
GE	General Electric Co. Schenectady, N.Y.	SP	Sprague Specialties Co. North Adams, Mass
GU	E.I. Guthman Co. Chicago, Illinois	ST	Standard Transformer Corp. Chicago, Illinois
H	The Hallicrafters Co. Chicago, Illinois	U	Utah Radio Products Co. Chicago, Illinois