

OPERATING
ALIGNMENT and SERVICING
INSTRUCTIONS
for the
SKYRIDER MARINE
MODEL S-22-R

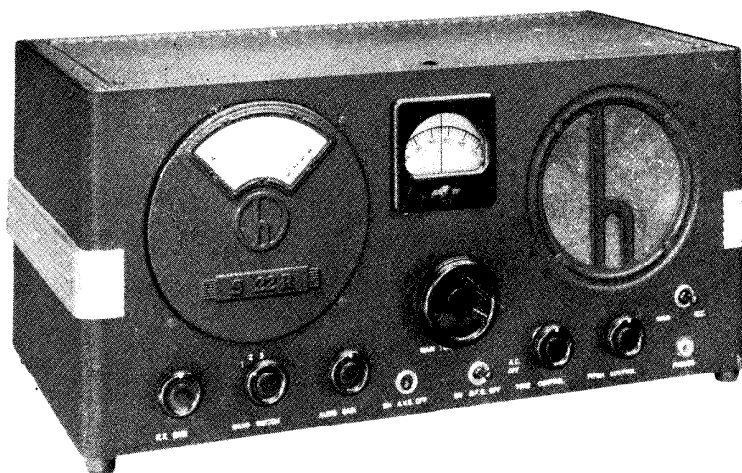

the hallicrafters *inc.*

CHICAGO U.S.A.

101022R40

OPERATING AND ALIGNMENT INSTRUCTIONS

SKYRIDER MARINE MODEL S22R

INSTALLATION: - It is recommended that, upon receipt, the carton and then the receiver be carefully examined for any damage which might have occurred in transit. File claim with the Carrier immediately should any sign of damage be apparent.

NOTE: The SKYRIDER MARINE Model S22R is an AC-DC receiver which operates on 110/125 volts only. Should operation be desired from a lower voltage DC source, an external converter delivering 110/125 volts should be used. A 220 volt DC Model S22R is available on order and uses a special line cord with dropping resistor.

Cabinet Dimensions: Length 18½" Depth 9¼" Height 8½". The receiver can be placed in any location convenient to its power source and antenna. Inasmuch as the Model S22R chassis is at the same ground potential as the cabinet the possibility of a short between chassis and cabinet is removed.

ANTENNA: - On the rear chassis apron will be found the Antenna Strip. A conventional Marconi, inverted "L", antenna should be connected to the A₁ terminal and the jumper between A₂ and G left connected. In order to get the most satisfactory pickup throughout the low frequency tuning range of the receiver, it is advisable to use the longest piece of wire for an antenna that it is possible to install. This same antenna will also perform satisfactorily on the higher frequencies. Should a commercially available "all wave" doublet antenna be used, the two wire transmission line from the flat top or matching transformer should be connected to terminals A₁ and A₂ with the jumper removed from A₂ and G. Should you wish to have a separate antenna for some one short wave frequency or band, a half wave antenna cut for that frequency will be an excellent performer. The following formula will give the length of the 1/2 wavelength antenna depending on the desired frequency.

Length in feet $\frac{463}{\text{frequency in megacycles}}$ or
for example, a half wave 40 meter antenna would be $\frac{463}{7} = 66.14$ feet long. A good

ground, if it aids reception, should be connected at the G terminal.

OPERATION: - After connecting an aerial to the receiver, plug the power cord into the power socket. Now turn the control marked "Tone" to the right. Power is now connected to the receiver as will be indicated by the dial light behind the translucent dials. Allow a few moments for the tubes in the receiver to reach operating temperature.

Place the band switch in position #2 for standard broadcast coverage. The frequency range of the receiver by bands is as follows:

- Band 1 - 110 Kc to 410 Kc
(2730 to 733 meters)
- Band 2 - 400 Kc to 1500 Kc
(750 to 200 meters)
- Band 3 - 1.7 Mc to 5.9 Mc
(177 to 51 meters)
- Band 4 - 5.3 Mc to 18 Mc
(56 to 16.7 meters)

The sensitivity of the receiver is adjusted by the "RF Gain" control.

The "AF Gain" control adjusts the volume of both the loud speaker and headphone circuits. **NOTE:** When receiving telephone signals, the AVC or automatic volume control switch should preferably be ON. The "RF Gain" is then rotated clockwise as far as it will go, or the position of maximum sensitivity. The signal is then adjusted for a level of volume to suit your particular requirements with the A. F. Gain control. With the AVC switch OFF, the sensitivity of the receiver should be manually controlled by suitable adjustment of the RF Gain control or the receiver will block or overload. After you have familiarized yourself with the operation of the receiver you will determine the proper settings of these controls for the most favorable signal to noise ratio.

The BFO switch places the beat frequency oscillator in operation when snapped to the ON position. Adjustment of the knob

marked "Pitch Control" will enable you to change the pitch of the beat note to one most pleasing to you. The "Send Receive" switch, in the SEND position, removes plate voltage from the tubes in the receiver which makes it inoperative during a transmission or stand-by period.

Inasmuch as no direct current flows in the headphone circuit, crystal type headphones can be used. When headphones are plugged into the headphone jack, the speaker is

automatically disconnected.

NOTE: In keeping with the Underwriters recommendations the fuse block is mounted on the under side of the chassis. 250 volt 2 ampere replacement fuses can be installed only after the bottom plate has been removed from the receiver.

The Model S22R SKYRIDER Marine Receiver draws 50 watts at 117 volts 60 cycles A.C.

GUARANTEE

This receiver is guaranteed to be free from any defect in workmanship and material that may develop within a period of ninety (90) days from date of purchase, under the terms of the standard guarantee, as designated by the Radio Manufacturers Association. Any part or parts that prove defective within this period will be replaced without charge when subjected to examination at our factory, providing such defect, in our opinion, is due to faulty material or workmanship, and not caused by tampering, abuse or normal wear. All such adjustments to be made FOB the factory.

Should this receiver require any adjustments, your dealer or distributor has complete technical service information, or the factory will be glad to assist you in

any problem direct.

Should it be necessary to return any part or parts to the factory, a "Return Material Permit" must be obtained in advance by first writing the Adjustment Department, who will issue due authorization under the terms of the guarantee.

The Hallicrafters, Inc., reserve the right to make changes in design or add improvements to instruments manufactured by them, without incurring any obligation to install the same in any instrument previously purchased.

All Hallicrafters receivers are built under patents of Radio Corporation of America and Hazeltine Corporation.

ALIGNMENT PROCEDURE

ALIGNMENT INSTRUCTIONS:

Equipment needed for aligning:

- 1 - An all wave signal generator which will provide an accurately calibrated signal at the test frequencies indicated.
- 2 - Output indicating meter connected to a headphone plug, and inserted in the headphone jack.
- 3 - Non-metallic screw driver.
- 4 - Dummy antenna of .002 mfd. condenser and 400 ohm resistor.

SETTING OF CONTROLS PRIOR TO ALIGNMENT - IF AND RF.

- 1 - Tone control at maximum high frequency position.
- 2 - AVC switch OFF.
- 3 - BFO switch OFF.
- 4 - RF Gain at maximum.
- 5 - AF gain at maximum.

1600 Kc IF ALIGNMENT.

Tune receiver to 5,000 Kc with the band switch in #3 position.

Connect hot side of signal generator to 6K8 grid cap through 1 MFD condenser - ground of generator to the chassis. Signal generator output - 1,600 Kc.

Adjust screws S1 to S6 inclusive on IF transformers T 1-2-3 for maximum gain.

BFO ADJUSTMENT - With a 1600 Kc signal being fed into the IF amplifier, and the BFO switch ON, place the Pitch Control with the white dot UP. Now adjust the screw S7 on the top of T5 for zero beat. Further adjustment of the Pitch Control from the front of the panel will enable you to vary the frequency of the beat note to your satisfaction.

R.F. ALIGNMENT

Connect hot Lead of Signal Generator to A_1 through dummy Antenna shown in Table.
 Leave Jumper connected between A_2 and G. Ground of Generator to Chassis.

BAND	REC. DIAL SETTING	SIG. GEN. FREQ.	DUMMY ANTENNA	HIGH FREQUENCY END		LOW FREQUENCY END
				ADJUST OSC WITH	ADJUST TRIMMERS WITH	ADJUST OSCILLATOR WITH
1	125 Kc	125 Kc	.002 mfd	-----	-----	P_1
	350 Kc	350 Kc	.002 mfd	C_C	C_A-C_B	-----
2	450 Kc	450 Kc	.002 mfd	-----	-----	P_2
	1400 Kc	1400 Kc	.002 mfd	C_F	C_E-C_D	-----
3	2 Mc	2 Mc	400 Ohm	-----	-----	P_3
	4.5 Mc	4.5 Mc	400 Ohm	C_J	C_G-C_H	-----
4	7 Mc	7 Mc	400 Ohm	-----	-----	P_4
	15 Mc	15 Mc	400 Ohm	C_M	C_L-C_K	-----

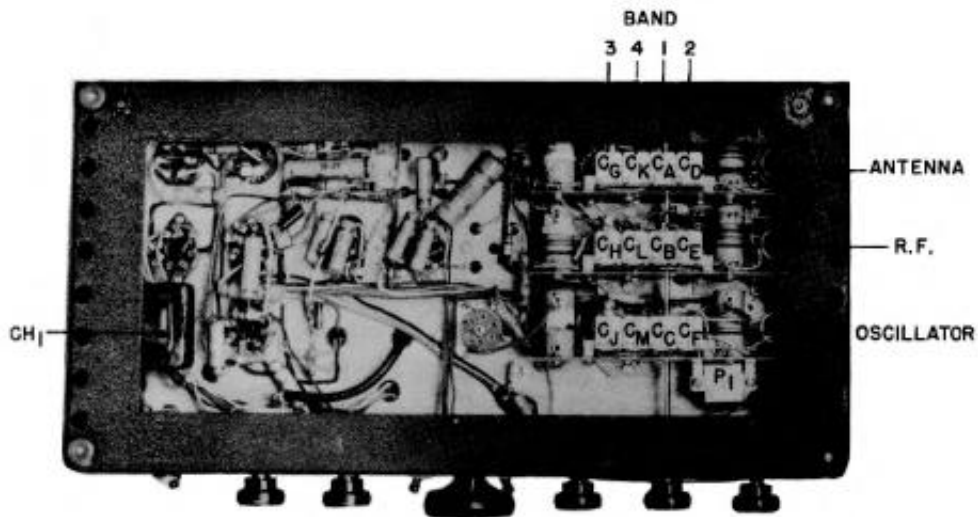
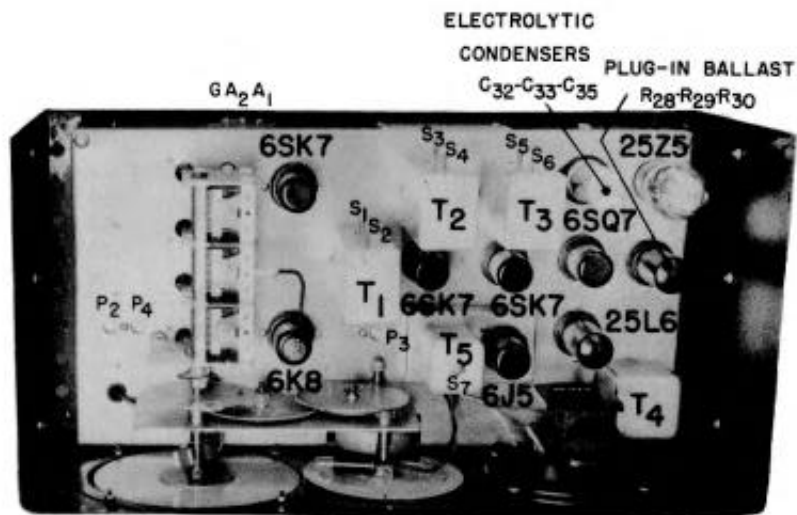

PARTS LIST

CONDENSERS

NO.	VALUE	VOLTAGE OR PURPOSE	TYPE	NO.	VALUE	VOLTAGE OR PURPOSE	TYPE
C ₁	Tuning Condenser	563 mmfd	per section	C ₂₆	.01 mfd	400 V.	Paper
C ₂	.01 mfd	400 V.	Paper	C ₂₇	.005 mfd	600 V.	Paper
C ₃	.05 mfd	400 V.	Paper	C ₂₈	.01 mfd	400 V.	Paper
C ₄	.05 mfd	400 V.	Paper	C ₂₉	250 mmfd		Mica
C ₅	5 mmf		Ceramicon	C ₃₀	200 mmfd		Mica
C ₆	5 mmf		Ceramicon	C ₃₁	5 mmf	BFO Pitch Con.	Air Variable
C ₇	.25 mfd	400 V.	Paper	C ₃₂	40 mfd	150 V.	Electrolytic
C ₈	.05 mfd	400 V.	Paper	C ₃₃	40 mfd	150 V.	Electrolytic
C ₉	.05 mfd	400 V.	Paper	C ₃₄	.05 mfd	400 V.	Paper
C ₁₀	.1 mfd	400 V.	Paper	C ₃₅	30 mfd	150 V.	Electrolytic
C ₁₁	.02 mfd	400 V.	Paper	C ₃₆	100 mmfd		Mica
C ₁₂	.02 mfd	400 V.	Paper	C ₃₇	2000 mmfd		Mica
C ₁₃	.01 mfd	400 V.	Paper	C ₃₈	32 mmfd	Band 1 Pad	
C ₁₄	.25 mfd	400 V.	Paper	C ₃₉	110 mmfd	Band 2 Pad	
C ₁₅	.02 mfd	400 V.	Paper	C ₄₀	480 mfd	Band 3 Pad	
C ₁₆	.02 mfd	400 V.	Paper	C ₄₁	1300 mfd	Band 4 Pad	
C ₁₇	.01 mfd	400 V.	Paper	C ₄₂	.1 mfd	200 V.	Paper
C ₁₈	10 mmf		Ceramicon				
C ₁₉	100 mmf		Mica				
C ₂₀	100 mmf		Mica				
C ₂₁	.02 mfd	400 V.	Paper				
C ₂₂	10 mf	25 V.	Electrolytic	SW1		A.V.C. "ON-OFF"	
C ₂₃	.05 mfd	400 V.	Paper	SW2		B.F.O. "ON-OFF"	
C ₂₄	250 mfd		Mica	SW3		Standby	
C ₂₅	.05 mfd	400 V.	Paper	SW4		A.C.-D.C. Line	

RESISTORS

NO.	VALUE IN OHMS	WATTAGE OR PURPOSE	NO.	VALUE IN OHMS	WATTAGE OR PURPOSE
R ₁	100,000	1/3	R ₁₇	250,000	1/3
R ₂	300	1/3	R ₁₈	1 Meg.	1/3
R ₃	25,000	R. F. Gain Control	R ₁₉	500,000	Audio Gain Control
R ₄	400	1/3	R ₂₀	7,500	1/3
R ₅	1,000	1/3	R ₂₁	100,000	1/3
R ₆	100,000	1/3	R ₂₂	250,000	1/3
R ₇	100,000	1/3	R ₂₃	500,000	Tone Control
R ₈	50,000	1/3	R ₂₄	140	1/2
R ₉	400	1/3	R ₂₅	100	1/2
R ₁₀	100,000	1/3	R ₂₆	5,000	1/3
R ₁₁	500	1/3	R ₂₇	250,000	1/3
R ₁₂	1,000	1/3	R ₂₈	Plug-in Ballast Tube Muter-Type BK29D	
R ₁₃	100,000	1/3	R ₂₉	Plug-in Ballast Tube Muter-Type BK29D	
R ₁₄	400	1/3	R ₃₀	Plug-in Ballast Tube Muter-Type BK29D	
R ₁₅	1,000	1/3	R ₃₁	25	1 Watt
R ₁₆	100,000	1/3	R ₃₂	4,000	1/2 Watt

The Hallicrafters Inc.

SCHEMATIC DIAGRAM - SKYRIDER MARINE - MODEL S-22 R

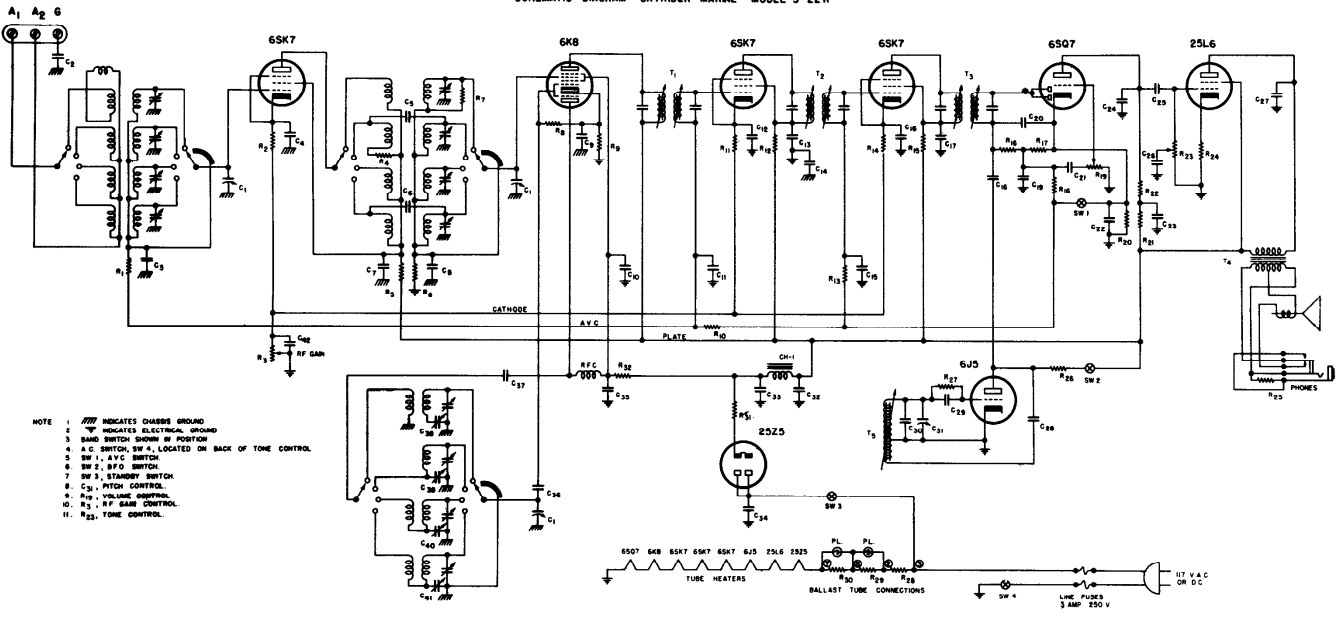

- NOTE
1. INDICATES CHASSIS GROUND
 2. INDICATES ELECTRICAL GROUND
 3. BAND SWITCH SHOWN IN POSITION
 4. A.C. SWITCH SW 4 LOCATED ON BACK OF TONE CONTROL
 5. SW 1, A.V.C. SWITCH
 6. SW 2, S.F.D. SWITCH
 7. SW 3, STANDBY SWITCH
 8. C23, PITCH CONTROL
 9. R24 - VOLUME CONTROL
 10. R13, R.F. GAIN CONTROL
 11. R23, TONE CONTROL