

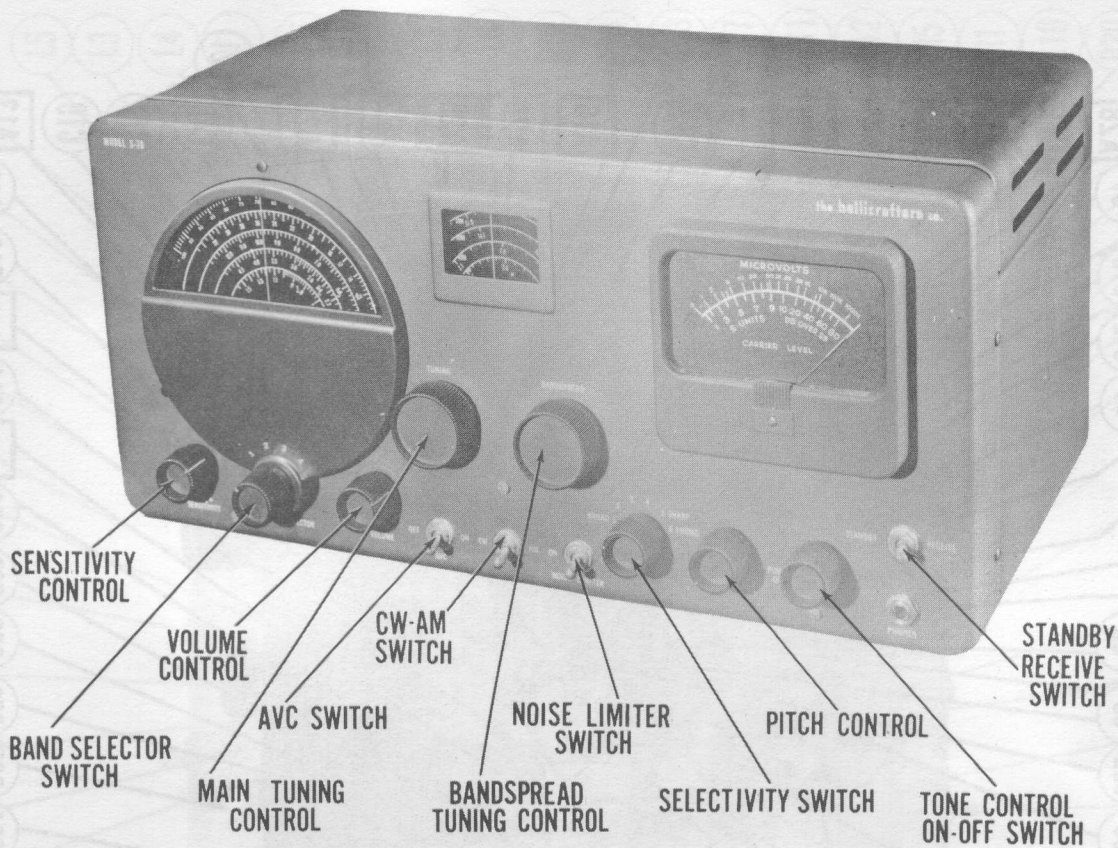

**HALLICRAFTERS
MODELS S-76, S-76U**



**HALLICRAFTERS
MODELS S-76, S-76U**

TRADE NAME	Hallicrafters, Models S-76, S-76U
MANUFACTURER	The Hallicrafters Co., 5th. and Kostner Avenues, Chicago, Illinois
TYPE SET	AC Operated Multi-Band Superheterodyne Communications Type Receiver
TUBES (ELEVEN)	Types 6CB6 RF Amp., 6AU6 1650KC Mixer, 6C4 Oscillator, 6BA6 1650KC IF Amp., 6BE6 50KC Converter, 6BA6 50KC IF Amp., 6AL5 DET-AVC-Noise Limiter, 6SC7 AF Amp.-BF0, 6K6GT Power Output, VR-150/0D3 Voltage Regulator, 5Y3GT Rectifier
POWER SUPPLY	105-125 Volts AC (Model S-76), 105 or 250 Volts AC (Model S-76U)
RATING	.71 Amp. at 117 Volts AC
TUNING RANGE	Band 1 538-1580KC, Band 2 1720KC-4.9MC, Band 3 4.6-13MC, Band 4 12-34MC

HOWARD W. SAMS & CO., INC. • Indianapolis 5, Indiana

"The listing of any available replacement part herein does not constitute in any case a recommendation, warranty or guaranty by Howard W. Sams & Co., Inc., as to the quality and suitability of such replacement part. The numbers of these parts have been compiled from information furnished to Howard W. Sams & Co., Inc., by the manufacturers of the particular type of replacement part listed."
"Reproduction or use, without express permission, of editorial or pictorial con-

tent, in any manner, is prohibited. No patent liability is assumed with respect to the use of the information contained herein. Copyright 1952 by Howard W. Sams & Co., Inc., Indianapolis 5, Indiana, U. S. of America. Copyright under International Copyright Union. All rights reserved under Inter-American Copyright Union (1910) by Howard W. Sams & Co., Inc." Printed in U. S. of America

MODEL 2-75-2-75A
MANUFACTURED

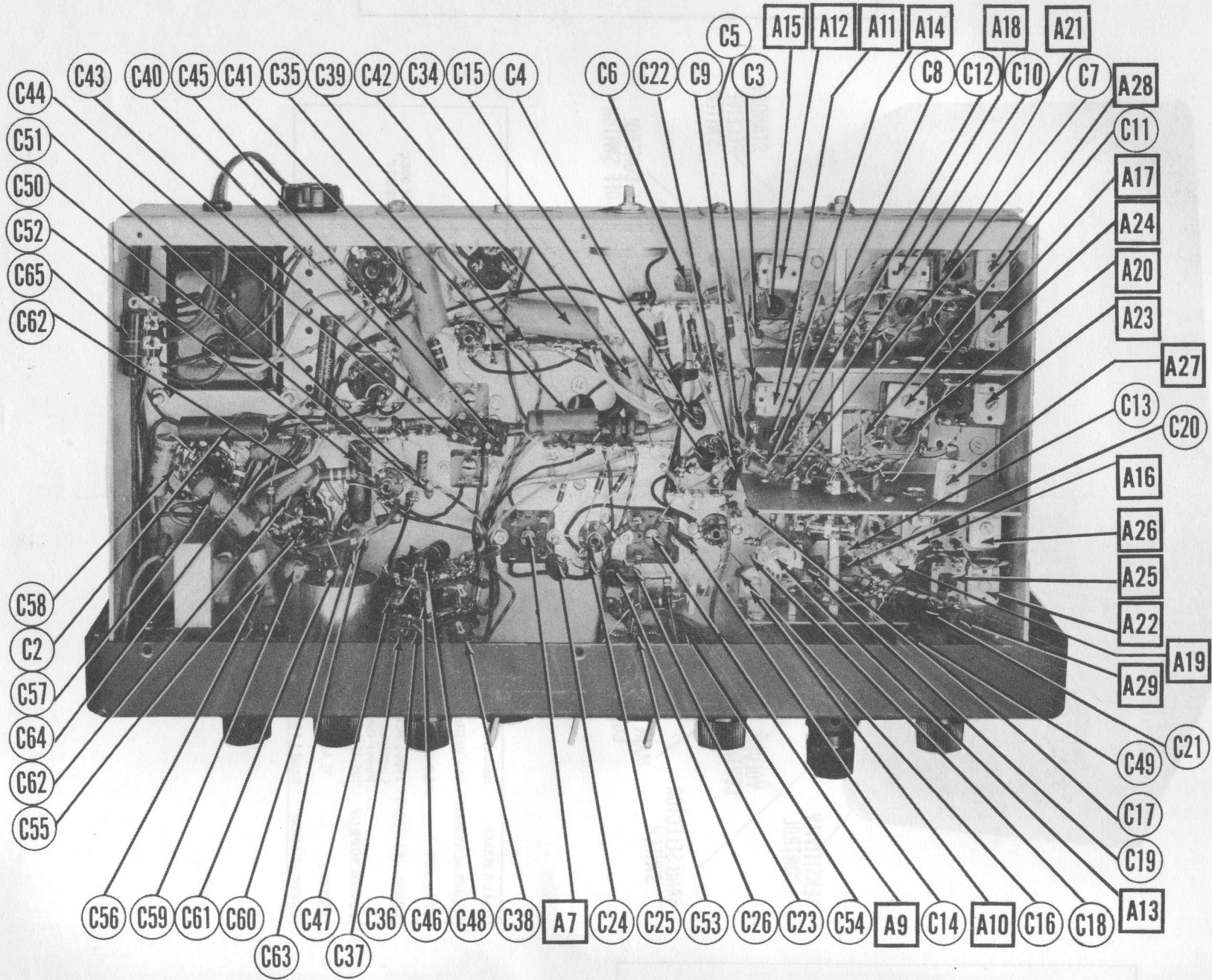

REMOVED BY TYPE 4-10-64C - INSTRUMENTS DIVISION

MODEL 2-75-2-75A
MANUFACTURED



Photocopy, Folger

MODEL 2-75-2-75A
MANUFACTURED

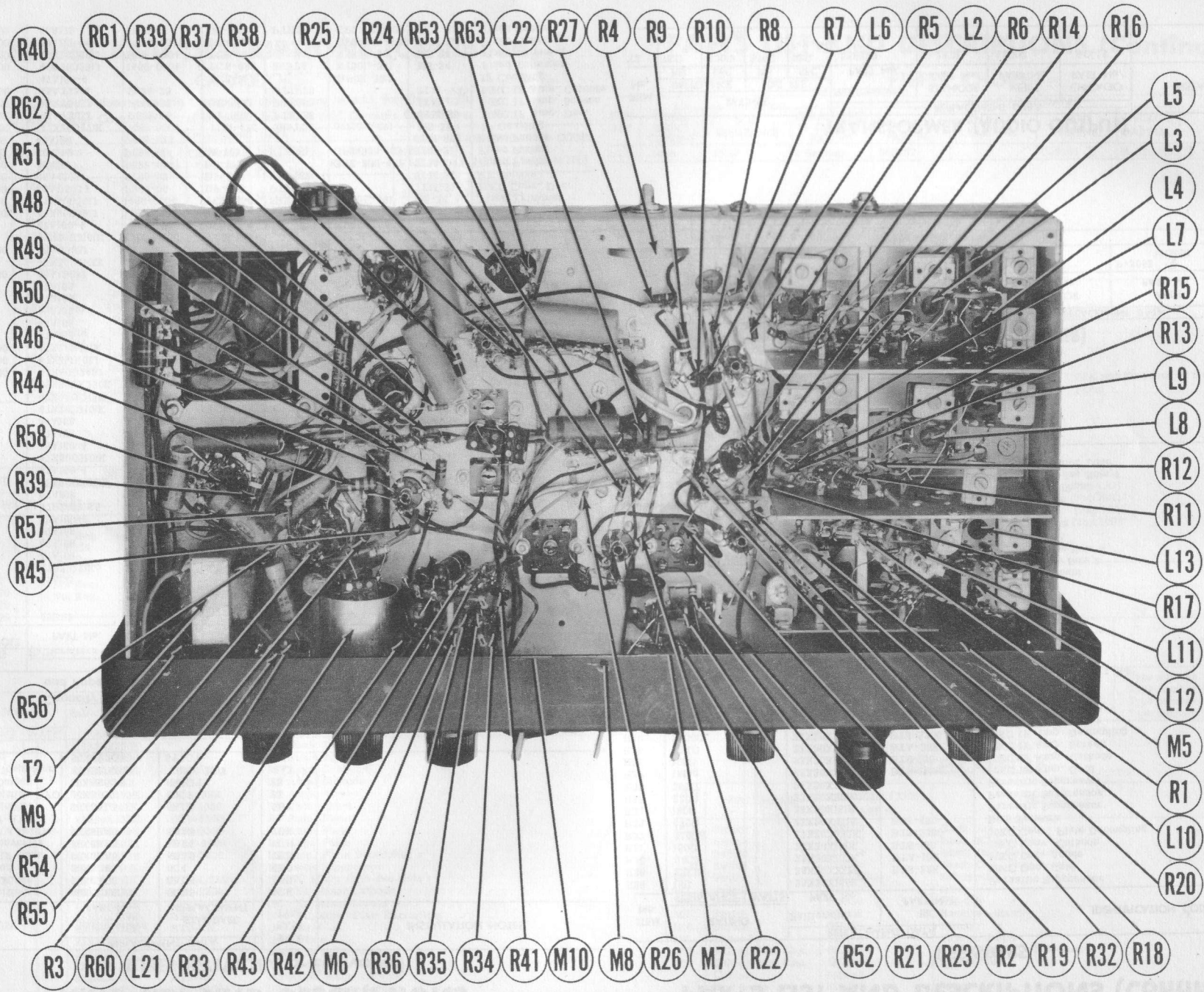

**HALLCRAFTERS
MODELS S-76, S-76U**

PARTS LIST AND DESCRIPTIONS

TUBES (SYLVANIA or Equivalent)

ITEM No.	USE	REPLACEMENT DATA			RMA BASE TYPE	INSTALLATION NOTES
		Hallicrafters PART No.	STANDARD REPLACEMENT			
V1	RF Amplifier	90X6CB6	6CB6	6CK		
V2	1650KC Mixer	90X6AU6	6AU6	7BK		
V3	Oscillator	90X6C4	6C4	6BG		
V4	1650KC IF Amp.	90X6BA6	6BA6	7BK		
V5	50KC Converter	90X6BE6	6BE6	7CH		
V6	50KC IF Amplifier	90X6BA6	6BA6	7BK		
V7	Detector-AVC-Noise Limiter	90X6AL5	6AL5	6BT		
V8	AF Amplifier-BFO	90X6SC7	6SC7	8S		
V9	Power Output	90X6K6GT	6K6GT	7S		
V10	Voltage Regulator	VR150/0D3	VR150/0D3	4AJ		
V11	Rectifier	90X5Y3GT	5Y3GT	5T		

CAPACITORS

Capacity values given in the rating column are in mfd. for Electrolytic and Paper Capacitors, and in mmfd. for Mica and Ceramic Capacitors.

ITEM No.	RATING		REPLACEMENT DATA						IDENTIFICATION CODES AND INSTALLATION NOTES
	CAP.	VOLT	Hallicrafters PART No.	AEROVOX PART No.	CENTRAL LAB PART No.	CORNELL-DUBILIER PART No.	ERIE PART No.	SPRAGUE PART No.	
C1A	60	450	45B113					UPT62245	▲ Filter
B	20	450							■ Filter
C	20	450							▲ Filter
C2	10	25	45A121	PRS25/10				TVA-1204	Output Cathode
C3	220		47B20221K5	BPD-005	D6-221			5GA-T22	RF Coupling
C4	5000		47A168	BPD-005	DD-502			5HK-D5	RF Amp. Screen
C5	5000		47A168	BPD-005	DD-502			5HK-D5	RF Amp. Cathode
C6	5000		47A168	BPD-005	DD-502			5HK-D5	AVC Filter
C7	2.2		47A160-4		TCZ-2.2			NPOK-2R2	Fixed Trimmer
C8	220		47B20221K5	SI220	D6-221			5GA-T22	RF Bypass
C9	5000		47A168	BPD-005	DD-502			5HK-D5	RF Bypass
C10	25		47X20K250K					N750K-250	RF Coupling
C11	2.2		47A160-4		TCZ-2.2			NPOK-2R2	RF Coupling
C12	100		47X20UJ101K	SI100N750	TCN-100			N750L-101	RF Coupling
C13	2.2		47A160-4		TCZ-2.2			NPOK-2R2	RF Coupling
C14	5000		47A168	BPD-005	DD-502			5HK-D5	Osc. Coupling
C15	5000		47A168	BPD-005	DD-502			5HK-D5	1650KC Mixer Plate
C16	100		47X20UJ101K	SI100N750	TCN-100			N750L-101	1650 KC Mixer Screen
C17	100		47X20UJ101K	SI100N750	TCN-100			N750L-101	Osc. Feedback
C18	25		47X20K250K					N750K-250	Osc. Grid Cap.
C19	2400	500	47X30D242J	1464-0025				1R5D25	Fixed Trimmer
C20	1000	500	47X25D102J	1464-001				1R5D1	Fixed Padder
C21	470	500	47X20B471K	1469-0005	TCN-470			5R5T5	Fixed Padder
C22	5000		47A168	BPD-005	DD-502			5R5T5	1650KC Mixer Cathode
C23	5000		47A168	BPD-005	DD-502			5R5T5	AVC Filter
C24	5000		47A168	BPD-005	DD-502			5R5T5	1650KC IF Amp. Dec.
C25	5000		47A168	BPD-005	DD-502			5R5T5	1650 KC IF Amp. Screen
C26	5000		47A168	BPD-005	DD-502			5R5T5	1650 KC IF Amp. Cathode
C27	.05	200	46A U503J	P288-05	DF-503			PTE455	Osc. Anode Dec.
C28	100		47X20UJ101K	SI100N750	TCN-100			N750L-101	Osc. Grid Cap.
C29	.05	200	46A U503J	P288-05	DF-503			PTE455	Conv. Cathode
C30	100		47X20UJ101K	SI100N750	TCN-100			N750L-101	Fixed Trimmer
C31	2.2		47A160-4		TCZ-2.2			NPOK-2R2	IF Coupling
C32	390	500	47X20D391J	1469-0004	TCN-390			5R5T4	Fixed Trimmer
C33	390	500	47X20D391J	1469-0004	TCN-390			5R5T4	Fixed Trimmer
C34	.05	200	46A U503 J	P288-05	DF-503			PTE455	50K Conv. Dec.
C35	.02	600	46A4203J	P688-02	DF-203			PTE6S2	RF Bypass
C36	.0047	600	46A181	P688-0047	D6-472			PTE6S1	Fixed Padder
C37	.01	600	46A179	P688-01	D6-103			PTE6S1	Fixed Padder
C38	.022	600	46A180	P688-022				PTE6S1	Fixed Padder
C39	470	500	47X20B471K	1469-0005	TCN-470			5R5T5	IF Coupling
C40	.05	600	46A Y503J	P688-05	DF-503			PTE6S5	50KC IF Amp. Dec.
C41	.05	600	46A Y503J	P688-05	DF-503			PTE6S5	50KC IF Amp. Screen
C42	.25	200	46A T254J	P488-25				G72P25	50KC IF Amp. Cathode
C43	2.2		47A160-4		TCZ-2.2			NPOK-2R2	IF Coupling
C44	390	500	47K20D391J	1469-0004	TCN-390			5R5T4	Fixed Trimmer
C45	390	500	47X20D391J	1469-0004	TCN-390			5R5T4	Fixed Trimmer
C46	.0047	600	46A181	P688-0047	D6-472			GP2-333-472	Fixed Padder
C47	.01	600	46A179	P688-01	D6-103			GP2-333-103	Fixed Padder

PARTS LIST AND DESCRIPTIONS (Continued)

RESISTORS

ITEM No.	RATING		REPLACEMENT DATA		IDENTIFICATION CODES
	RESISTANCE	WATTS	Hallicrafters PART No.	IRC PART No.	
R28	15Ω		23X20X150K		Parasitic Suppressor
R29	22KΩ		23X20X223K	BTS-22K	50KC Osc. Grid
R30	10KΩ		23X30X103K	BTA-10K	50KC Osc. Anode
R31	150Ω		23X20X151K	BTS-150	50KC Conv. Cathode
R32	3300Ω		23X20X332K	BTS-3300	50KC Conv. Plate Decoupling
R33	470Ω		23X20X471K	BTS-470	Bias Network
R34	180Ω		23X20X181K		Parasitic Suppressor
R35	220Ω		23X20X221K		Parasitic Suppressor
R36	390Ω		23X20X391K		Parasitic Suppressor
R37	1Meg		23X20X105K	BTS-1Meg	50KC IF Amp. Grid
R38	100Ω		23X20X101K	BTS-100	50KC IF Amp. Cathode
R39	39KΩ		23X30X393K	BTA-39K	50KC IF Amp. Screen
R40	3300Ω		23X20X332K	BTS-3300	50KC IF Amp. Decoupling
R41	180Ω		23X20X181K		Parasitic Suppressor
R42	220Ω		23X20X221K		Parasitic Suppressor
R43	390Ω		23X20X391K		Parasitic Suppressor
R44	6.8Ω		23X30X068K		Diode Filament
R45	1.5Meg		23X20X155K	BTS-1.5Meg	Noise Limiter Diode Load
R46	1Meg		23X20X105K	BTS-1Meg	Voltage Divider
R47	1Meg		23X20X105K	BTS-1Meg	Voltage Divider
R48	82KΩ		23X20X823K	BTS-82K	Det. Diode Load
R49	330KΩ		23X20X334K	BTS-330K	Det. Diode Load
R50	47KΩ		23X20X473K	BTS-47K	AVC Network
R51	3.3Meg		23X20X335K	BTS-3.3Meg	AVC Network
R52	100Ω		23X20X101K	BTS-100	AVC Network
R53	470KΩ		23X20X474K	BTS-470K	Phono Input Shunt
R54	120KΩ		23X20X124K	BTS-120K	BFO Grid-See Note 2
R55	39KΩ		23X20X393K	BTS-39K	BFO Plate-See Note 3
R56	15Meg		23X20X156K	BTS-15Meg	AF Amp. Grid
R57	220KΩ		23X20X224K	BTS-220K	AF Amp. Plate
R58	470KΩ		23X20X474K	BTS-470K	Output Grid
R59	390Ω		23X30X391K	BTA-390	Output Cathode
R60	560Ω		23X30X561K	BTA-560	Output XFMR Shunt
R61	390KΩ		23X20X394K	BTS-390K	Bias Network-See Note 4
R62	3000Ω	10	24B302E	1/3/4A-3000	Voltage Regulator Load
R63	10KΩ		23X20X103K	BTS-10K	Filter

Note 1 Some models use 2.2Meg resistor in this application.
 Note 2 Some models use 100KΩ resistor in this application.
 Note 3 Some models use 47KΩ resistor in this application.
 Note 4 Some models use 350KΩ resistor in this application.

TRANSFORMER (POWER)

ITEM No.	RATING				REPLACEMENT DATA			
	PRI.	SEC. 1	SEC. 2	SEC. 3	Hallicrafters PART No.	STANCO PART No.	MERIT PART No.	CHICAGO PART No.
T1	117VAC ④ .71A	540VCT .105ADC	5VAC ② 2A	6.3VAC ③ 3.5A	52C221 52C222 ①		P-3052 ④	PH-120 ③

① Used in model S-76U.
 ② Add series resistor to reduce plate voltage.
 ③ Drill new mounting holes.

TRANSFORMER (AUDIO OUTPUT)

ITEM No.	RATING				REPLACEMENT DATA			
	IMPEDANCE		DC RES.		Hallicrafters PART No.	STANCO PART No.	MERIT PART No.	CHICAGO PART No.
T2	7KΩ	500Ω	370Ω	52Ω	55B120	A-3878	A2900	RO-13

PARTS LIST AND DESCRIPTIONS (Continued)

CAPACITORS

Capacity values given in the rating column are in mfd. for Electrolytic and Paper Capacitors, and in mmfd. for Mica and Ceramic Capacitors.

ITEM No.	RATING		REPLACEMENT DATA					IDENTIFICATION CODES AND INSTALLATION NOTES	
	CAP.	VOLT	Hallcrafters PART No.	AEROVOX PART No.	CENTRALAB PART No.	CORNELL-DUBILIER PART No.	ERIE PART No.		SPRAGUE PART No.
C48	.022	600	46A180	P688-022				6TM-S22	Fixed Padder
C49	.25	200	46A T254J	P488-25				2TM-P25	RF Bypass
C50	220		47B20221K5	SI220	D6-221	5R5T25	GP2K-221	5GA-T22	Diode RF Filter
C51	220		47B20221K5	SI220	D6-221	5R5T25	GP2K-221	5GA-T22	Diode RF Filter
C52	.02	600	46AY203J	P688-02	DF-203	PTE6S2		6TM-S2	Audio Coupling
C53	.02	600	46AY203J	P688-02	DF-203	PTE6S2		6TM-S2	Audio Coupling
C54	.02	600	46AY203J	P688-02	DF-203	PTE6S2		6TM-S2	Audio Coupling
C55	220		47B20221K5	SI220	D6-221	5R5T25	GP2K-221	5GA-T22	RF Bypass
C56	.005	600	46AY502J	P688-005	D6-502	PTE6D5	GP2-333-502	6TM-D5	Tone Comp.
C57	.02	600	46AY203J	P688-02	DF-203	PTE6S2		6TM-S2	Audio Coupling
C58	.01	600	46X35X103J	P688-01	D6-103	PTE6S1	GP2-333-103	6TM-S1	Output Plate
C59	.02	600	46AY203J	P688-02	DF-203	PTE6S2		6TM-S2	BFO Feedback
C60	470	500	47X20B47K	1469-0005		5R5T5		MS-35	BFO Grid Cap.
C61	560	500	47X20D561J						Fixed Trimmer
C62	.02	600	46AY203J	P688-02	DF-203	PTE6S2		6TM-S2	RF Bypass
C63	47		47X20UK470K	SI47	D6-470	5R5Q5	GPIK-470	5GA-Q47	BFO Coupling
C64	.05	200	46AU503J	P288-05	DF-503	PTE4S5		2TM-S5	Noise Limiter Filter
C65	.01	600	46X35X103J	P688-01	D6-103	PTE6S1	GP2-333-103	6TM-S1	Line Filter

CONTROLS

ITEM No.	RATING		REPLACEMENT DATA				INSTALLATION NOTES
	RESISTANCE	WATTS	Hallcrafters PART No.	IRC PART No.	CLAROSTAT PART No.	CENTRALAB PART No.	
RIA	10KΩ	1/2	25B590	Q13-116	AM-81-Z	B-15	Sensitivity Control
B	Shaft		Not Req.	Not Req.	RS-2	Not Req.	Attach to R1A Per Instructions.
R2A	500KΩ	1/2	25B534	Q13-133	AM-60-Z	B-60	Volume Control
B	Shaft		Not Req.	Not Req.	RS-2	Not Req.	Attach to R2A Per Instructions.
R3A	500KΩ	1/2	25B605	Q13-133	AG-60-Z	B-60-S	Tone Control
B	Shaft		Not Req.	Not Req.	RS-2	Not Req.	Attach to R3A Per Instructions.
C	Switch		Not Req.	Not Req.	SWB	Not Req.	Attach to R3A Per Instructions.
R4	500Ω	4		76-1	RTV-25		"S" Meter Adjustment-Wire Wound

RESISTORS

ITEM No.	RATING		REPLACEMENT DATA		IDENTIFICATION CODES
	RESISTANCE	WATTS	Hallcrafters PART No.	IRC PART No.	
R5	22Ω		23X20X220K		Parasitic Suppressor
R6	15Ω		23X20X150K		Parasitic Suppressor
R7	1Meg		23X20X105K	BTS-1Meg	RF Amp. Grid
R8	180Ω		23X20X181K	BTS-180	RF Amp. Cathode
R9	39KΩ		23X30X393K	BTA-39K	RF Amp. Screen
R10	1000Ω		23X20X102K	BTS-1000	RF Choke Shunt
R11	3300Ω		23X20X332K	BTS-3300	RF Amp. Plate
R12	3300Ω		23X20X332K	BTS-3300	RF Amp. Plate
R13	6800Ω		23X30X682K	BTA-6800	RF Amp. Plate
R14	3300Ω		23X20X332K	BTS-3300	RF Amp. Plate Decoupling
R15	15Ω		23X20X150K		Parasitic Suppressor
R16	1.5Meg		23X20X155K	BTS-1.5Meg	1650KC Mixer Grid-See Note 1
R17	2200Ω		23X20X222K	BTS-2200	1650 KC Mixer Cathode
R18	330KΩ		23X20X334K	BTS-330K	1650 KC Mixer Screen
R19	3300Ω		23X20X332K	BTS-3300	1650 KC Mixer Plate Decoupling
R20	22KΩ		23X20X223K	BTS-22K	Osc. Grid
R21	10KΩ		23X30X103K	BTA-10K	Osc. Plate
R22	15Ω		23X20X150K		Parasitic Suppressor
R23	120KΩ		23X20X124K	BTS-120K	AVC Network-See Note 2
R24	100Ω		22X20X101K	BTS-100	1650KC IF Amp. Cathode
R25	8200Ω		23X20X822K	BTS-8200	1650 KC IF Amp. Screen
R26	3300Ω		23X20X332K	BTS-3300	1650 KC IF Amp. Plate Decoupling
R27	270Ω		23X20X271K	BTS-270	"S" Meter Shunt

SET 143
FOLDER 9

PARTS LIST AND DESCRIPTIONS (Continued)

FILTER CHOKE

ITEM No.	RATINGS			REPLACEMENT DATA			INSTALLATION NOTES
	TOTAL DIRECT CURRENT	D. C. RESISTANCE	INDUCTANCE (0 CURRENT 1000 cps)	Hallcrafters PART No.	STANCOR PART No.	MERIT PART No.	
L1	.105A	330Ω	9 Henries	56B107		C-2995 ②	R-23110② ② One new mounting hole.

COILS (RF-IF)

ITEM No.	USE	DC RES.		REPLACEMENT DATA		NOTES
		PRI.	SEC.	Hallcrafters PART No.	MEISSNER PART No.	
L2	Ant. Coil	.2Ω	0Ω	51B1325		Band 4
L3	Ant. Coil	.3Ω	.1Ω	51B1324		Band 3
L4	Ant. Coil	.4Ω	1.5Ω	51B1323		Band 2
L5	Ant. Coil	28Ω	5.8Ω	51B1322		Band 1
L6	RF Choke	.3Ω		53A215		
L7	RF Coil	1.3Ω	0Ω	51B1327		Band 4
L8	RF Coil	9Ω	.1Ω	51B1326		Band 3
L9A	RF Coil	1.5Ω		51B1319		Band 2
L9B	RF Coil	6.5Ω				L9A and 9B wound on same Form
L10	Osc. Coil	2Ω	.1Ω	51B1321		Band 4
L11	Osc. Coil	.5Ω	.1Ω	51B1320		Band 3
L12	Osc. Coil	.5Ω	.9Ω	51B1329		Band 2
L13	Osc. Coil	.7Ω	2Ω	51B1328		Band 1
L14	1st IF	.8Ω	.8Ω	50B488		1650KC
L15	2nd IF	.8Ω	.8Ω	50B488		1650KC
L16	Osc. Coil	.4Ω		50B490		1600KC (Tap 2Ω)
L17	1st IF Pri.	32Ω		50B489		50KC (Tap 14Ω)
L18	1st IF Sec.	32Ω		50B489		50KC (Tap 14Ω)
L19	2nd IF Pri.	32Ω		50B489		50KC (Tap 14Ω)
L20	2nd IF Sec.	32Ω		50B489		50KC (Tap 14Ω)
L21	BFO Osc. Coil	100Ω		54B045		(Tap 69Ω)
L22	RF Choke	9Ω		53A107		

DIAL LIGHTS

ITEM No.	BASE TYPE	VOLTS	AMPS.	BEAD COLOR	REPLACEMENT DATA		NOTES
					Hallcrafters PART No.		
M1	Bayonet	6-8	.25	Blue	39A003		Type number 44.
M2	Bayonet	6-8	.25	Blue	39A003		Type number 44.
M3	Bayonet	7.5	.2	White			Type number 51.
M4	Bayonet	7.5	.2	White			Type number 51.

MISCELLANEOUS

ITEM No.	PART NAME	HALLCRAFTERS PART No.	NOTES
M5A	Switch	62B053	Band, Ant. Section
B	Switch	62B053	Band, RF Section
C	Switch	62B054	Band, Osc. Grid Section
D	Switch	62B055	Band, Osc. Plate Section
M6	Switch	60B399	Selectivity
M7	Switch	60A138	AVC
M8	Switch	60A138	AM-CW
M9	Switch	60A192	Receiver-Standby
M10	Switch	60A138	Limiter
M11	Meter	82C183	Carrier Level
M12	3 Gang Var. Cap.	48C244	(12-420MMF) Each Section
M13	3 Gang Var. Cap.	48C243	Bandspread
	Cabinet	66D652	
	Dial Scale	83B387	Main
	Dial Scale	83B388	Bandspread

VOLTAGE READINGS

Item	Tube	Pin 1	Pin 2	Pin 3	Pin 4	Pin 5	Pin 6	Pin 7	Pin 8
V 1	6CB6	0V	26VDC	0V	6.3VAC	260VDC	255VDC	26VDC	
V 2	6AU6	-3.8VDC	0V	0V	6.3VAC	255VDC	70VDC	4.6VDC	
V 3	6C4	85VDC	0V	0V	6.3VAC	85VDC	§-11VDC	0V	
V 4	6BA6	0V	26VDC	0V	6.3VAC	260VDC	135VDC	26VDC	
V 5	6BE6	§-1.8VDC	1.4VDC	0V	6.3VAC	260VDC	85VDC	0V	
V 6	6BA6	0V	26VDC	0V	6.3VAC	250VDC	220VDC	26VDC	
V 7	6AL5	0V	-.1VDC	0V	4.3VAC	0V	0V	-.1VDC	
V 8	6SC7	0V	▲115VDC	-.5VDC ▲-6.1VDC	-.3VDC	95VDC	0V	0V	6.3VAC
V 9	6K6GT	0V	0V	265VDC	260VDC	0V	280VDC	6.3VAC	16VDC
V 10	VR-15Q0D3	0V	0V	140VDC	260VDC	140VDC	0V	140VDC	0V
V 11	5Y3GT	260VDC	280VDC	0V	280VAC	0V	280VAC	0V	280VDC

RESISTANCE READINGS

Item	Tube	Pin 1	Pin 2	Pin 3	Pin 4	Pin 5	Pin 6	Pin 7	Pin 8
V 1	6CB6	4.7Meg	10KΩ	0Ω	.1Ω	†10KΩ	†39KΩ	10KΩ	
V 2	6AU6	1.5Meg	0Ω	0Ω	.1Ω	†3.6KΩ	†330KΩ	2.2KΩ	
V 3	6C4	†13KΩ	Inf.	0Ω	.1Ω	†13KΩ	22KΩ	0Ω	
V 4	6BA6	3.8Meg	10KΩ	0Ω	.1Ω	†3.6KΩ	†11KΩ	10KΩ	
V 5	6BE6	22KΩ	150Ω	0Ω	.1Ω	†3.6KΩ	†13KΩ	.8Ω	
V 6	6BA6	1Meg	10KΩ	0Ω	.1Ω	†3.6KΩ	†42KΩ	10KΩ	
V 7	6AL5	390Ω	1.5Meg	0Ω	2.5Ω	2.4Meg	Inf.	450KΩ	
V 8	6SC7	0Ω	†▲42KΩ	120KΩ	15Meg	†230KΩ	0Ω	0Ω	.1Ω
V 9	6K6GT	Inf.	0Ω	†370Ω	†330Ω	470KΩ	†0Ω	.1Ω	390Ω
V 10	VR-15Q0D3	Inf.	0Ω	†3.3KΩ	†330Ω	†3.3KΩ	Inf.	†3.3KΩ	Inf.
V 11	5Y3GT	†330Ω	40KΩ	Inf.	70Ω	Inf.	78Ω	Inf.	40KΩ

▲ CW AND AM SWITCH IN CW POSITION.
 § TAKEN WITH VACUUM TUBE VOLTMETER.
 ALL MEASUREMENTS TAKEN IN BC BAND #1.
 ▲ CW AND AM SWITCH IN CW POSITION.
 † MEASURED FROM PIN 8 OF V11.
 SELECTIVITY SWITCH IN BROAD I.
 AVC SWITCH IN ON POSITION.
 NOISE LIMITER SWITCH IN ON POSITION.

- DC Voltage measurements are at 20,000 ohms per volt; AC Voltages measured at 1,000 ohms.
- Socket connections are shown as bottom views.
- Measured values are from socket pin to common negative.
- Line voltage maintained at 117 volts for voltage readings.
- Nominal tolerance on component values makes possible a variation of ±15% in voltage and resistance readings.
- Volume control at maximum, no signal applied for voltage measurements.

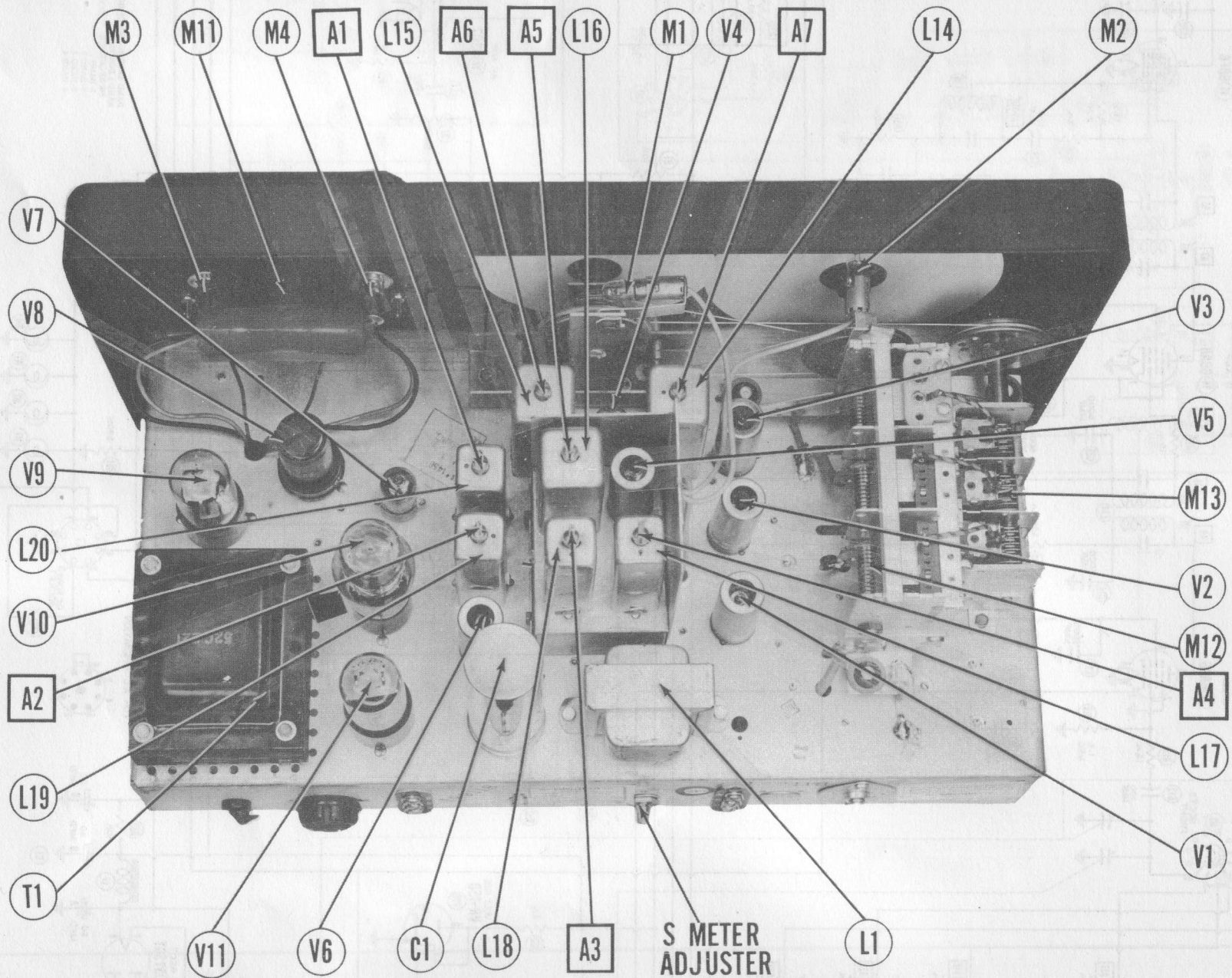

ALIGNMENT INSTRUCTIONS—READ CAREFULLY BEFORE ATTEMPTING ALIGNMENT

To set dial turn tuning gang fully closed and set the zero on the logging scale under the dial index line.
 Turn the noise limiter and AVC switches to "off", send-receive switch to "receive", CW/AM switch to AM, and the band selector to "band 2".
 Turn both main tuning and bandsread capacitors to half meshed.
 During alignment of the 50KC IFs, (step 1), remove the first oscillator tube, (V3), from its socket to prevent signal interference.
 Connect a 3.2 or 500Ω speaker.

DUMMY ANTENNA	SIGNAL GENERATOR COUPLING	SIGNAL GENERATOR FREQUENCY	BAND SWITCH POS.	RADIO DIAL SETTING	CONNECT VTVM	ADJUST	REMARKS
1. .01MFD	High side to terminal 1 on L15. Low side to chassis.	50KC (unmod.)	2	Tuning gang half meshed.	Use VTVM DC Probe to Point A. Common to chassis.	A1, A2, A3, A4	Adjust in the order given for maximum deflection. Then repeat the adjustments in the same order.
2. "	High side to stator on center section of main tuning gang. Low side to chassis.	1650KC	"	"	"	A5, A6, A7, A8, A9	Replace V3. Adjust A5 for maximum deflection. Then retune signal gen. for maximum deflection. Adjust A6, A7, A8, and A9 for maximum deflection, at the new frequency. Rotate the selectivity switch from step 5 to step 1. The reading on the VTVM should decrease progressively, if not repeat step.1.
3. "	High side to terminal 1 on L15. Low side to chassis.	50KC (unmod.)	"	"	Use speaker as indicator.		Turn CW/AM switch to "CW". Remove pitch control knob. Turn pitch control shaft for zero beat indication on speaker. Replace knob with indicator line straight up. Turn switch back to "AM".
Turn the BAND SPREAD, VOLUME, TONE, and SENSITIVITY controls fully clockwise. Turn the SELECTIVITY switch to 3. Leave all other controls as set.							
4. 330Ω carbon resistor	High side thru 330Ω to antenna terminal "A1", (connect link) Low side to chassis.	30MC (400% Mod.)	4	30MC	DC Probe to Point A. Common to chassis.	A10, A11, A12	Adjust for maximum deflection.
5. "	"	14MC	"	14MC	"	A13, A14, A15	Adjust for maximum deflection. Repeat steps 4 and 5 until no further improvement can be made.
6. "	"	11.5MC	3	11.5MC	"	A16, A17, A18	Adjust for maximum deflection.
7. "	"	5.1MC	"	5.1MC	"	A19, A20, A21	Adjust for maximum deflection. Repeat steps 6 and 7 until no further improvements can be made.
8. "	"	4.6MC	2	4.6MC	"	A22, A23, A24	Adjust for maximum deflection.
9. "	"	1.925MC	"	1.925MC	"	A25	Adjust for maximum deflection. Repeat steps 8 and 9 until no further improvement can be made.
10. "	"	1400KC	1	1400KC	"	A26, A27, A28	Adjust for maximum deflection.
11. "	"	600KC	"	600KC	" "	A29	Adjust for maximum deflection. Repeat steps 10 and 11 until no further improvement can be made.

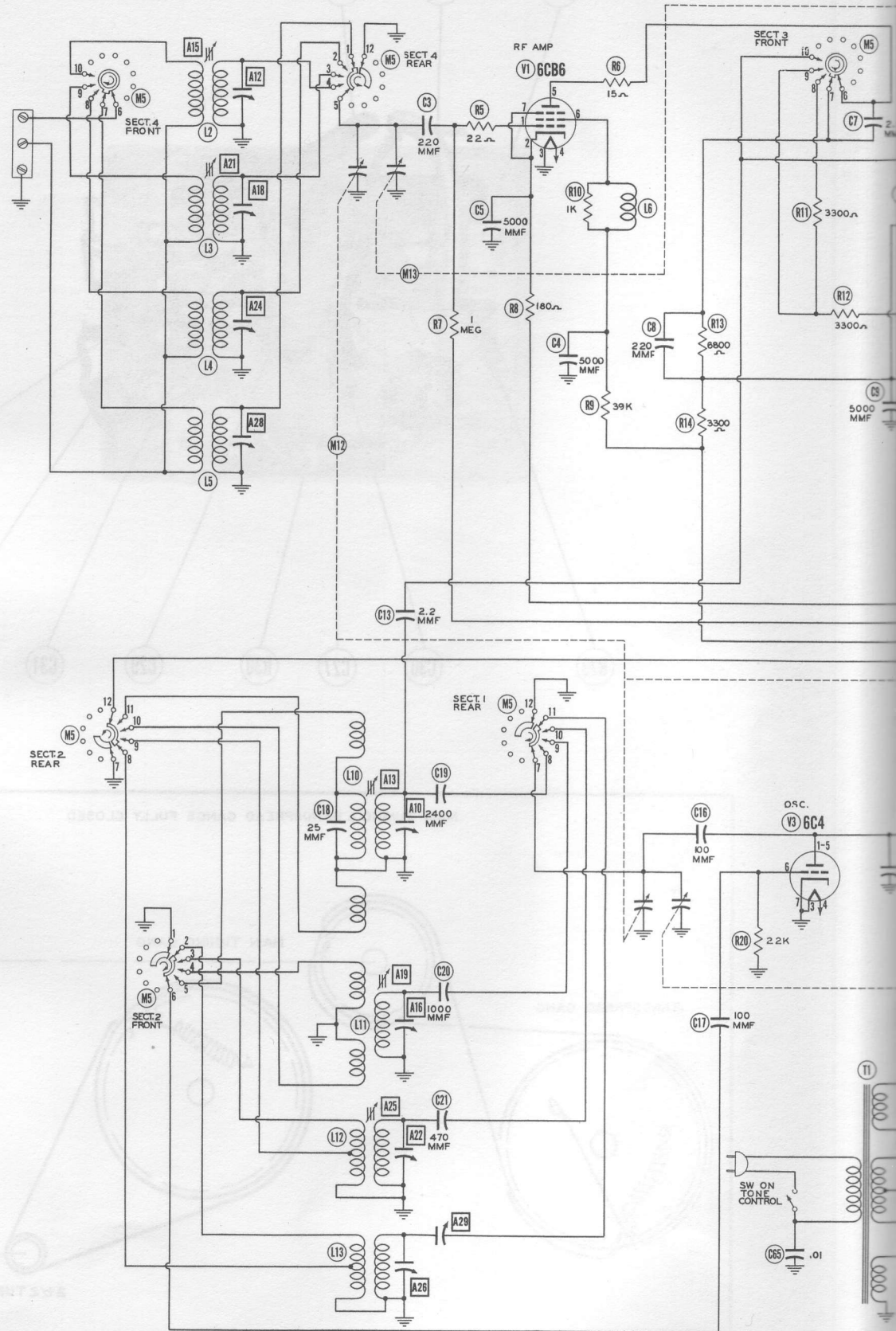

A PHOTOFAC STANDARD NOTATION SCHEMATIC
 © Howard W. Sams & Co., Inc. 1951

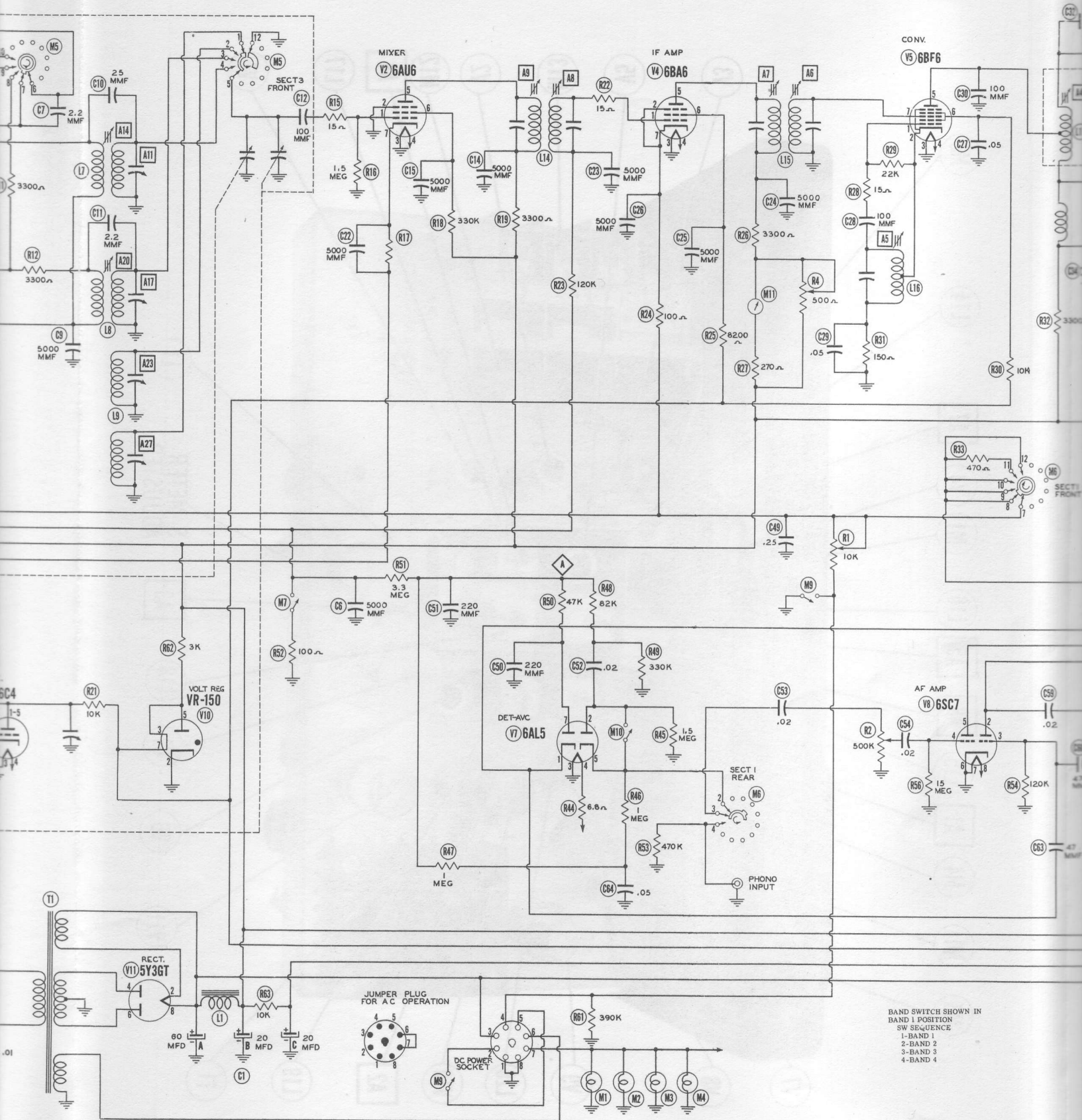

BAND SWITCH SHOWN IN BAND 1 POSITION
 SW SEQUENCE
 1-BAND 1
 2-BAND 2
 3-BAND 3
 4-BAND 4

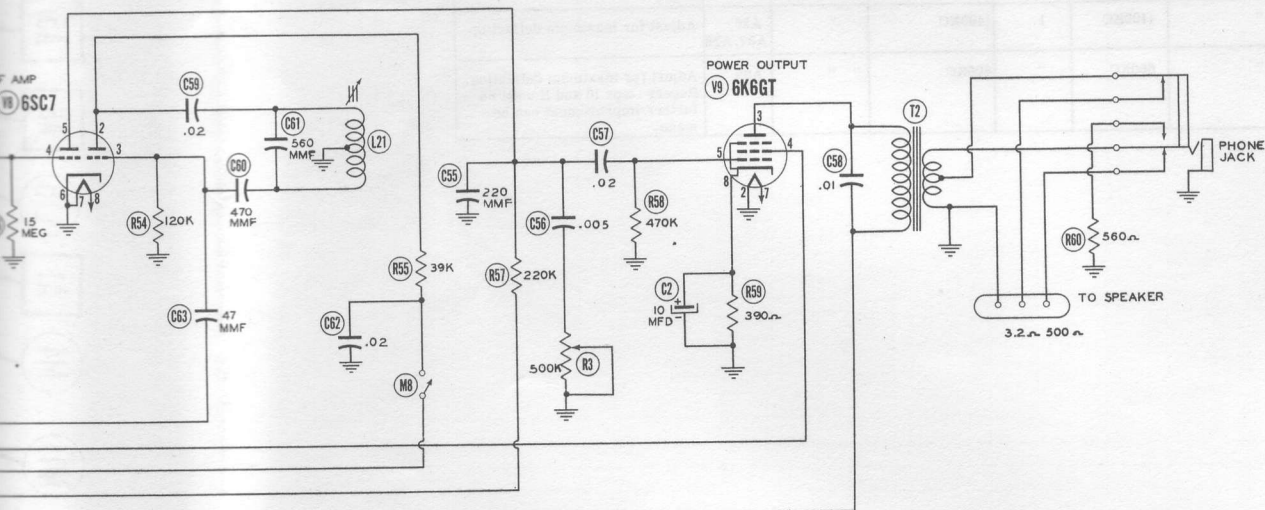
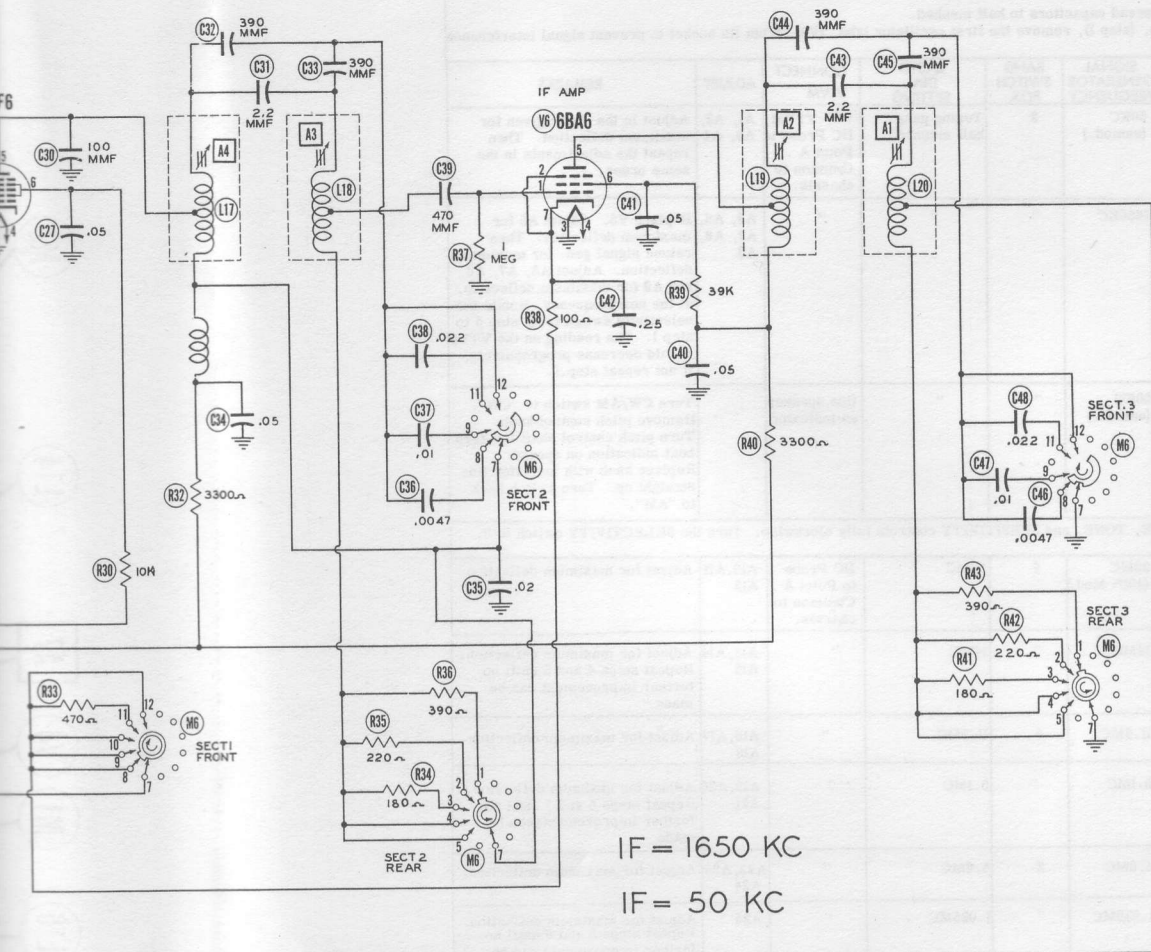

SWITCH SHOWN IN POSITION 1
SEQUENCE
1-BROAD
2-BROAD
3-NORMAL
4-SHARP
5-SHARP
6-PHONO

SELECTIVITY SWITCH SHOWN IN POSITION 1
SWITCH SEQUENCE
1-BROAD
2-BROAD
3-NORMAL
4-SHARP
5-SHARP
6-PHONO