

HALLICRAFTERS MODEL SX-43

HALLICRAFTERS MODEL SX-43

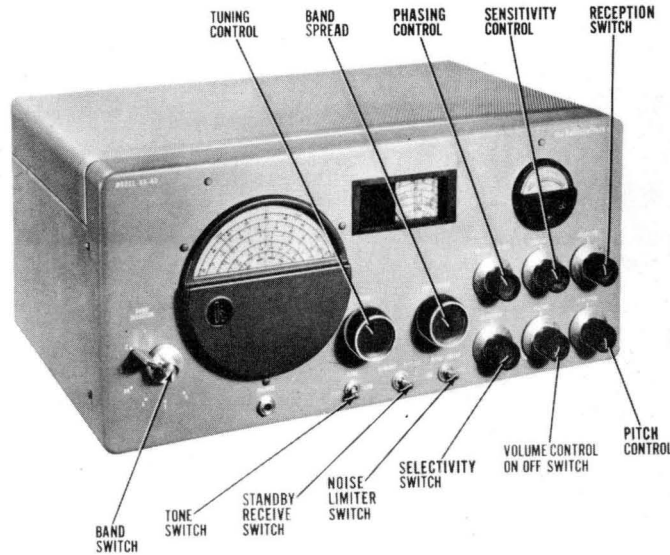

HALLICRAFTERS MODEL SX-43

TRADE NAME	Hallcrafters, Model SX-43		
MANUFACTURER	Hallcrafters Co., 5th & Kostner Avenues, Chicago 24, Ill.		
TYPE SET	AC Operated Multi-Band AM-FM Commercial Communications Receiver		
TUBES (ELEVEN)	Types, 6BA6 RF Amp., 7F8 Converter, 6SG7 1st IF Amp., 6SH7 2nd IF-2nd Mixer, 6SH7 3rd IF Amp., 6AL5 FM ratio Det., 6H6 AM Det., 6J5 BFO-2nd Osc., 6SQ7 AF Amp., 6V6GT Power Output, 5Y3GT Rectifier.		
POWER SUPPLY	105-125 Volts AC		
RATING	.68 Amp. @ 117 Volts AC		
TUNING RANGE-BROADCAST	540-1700KC	SHORT WAVE	1.7-5MC, 5-16MC, 14-14.4MC, 15.5-44MC, 44-55MC
		FREQ. MOD.	44-55MC, 86-109MC

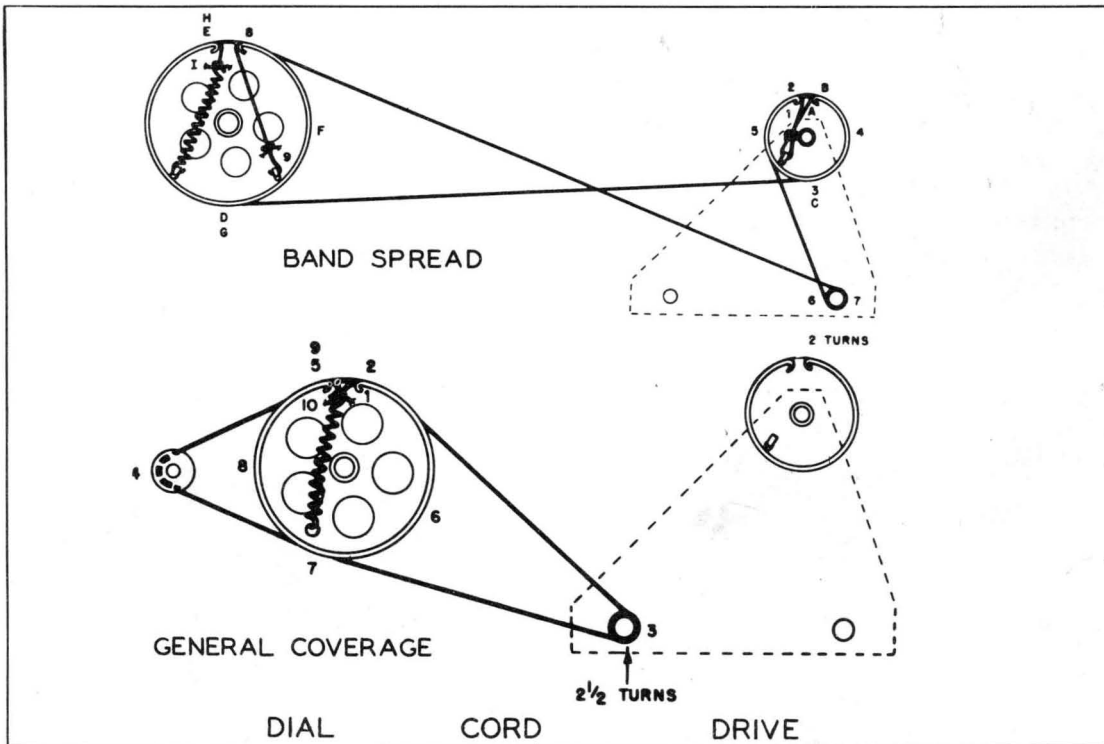

HOWARD W. SAMS & CO., INC.

Indianapolis Indiana

"The listing of any available replacement part herein does not constitute in any case a recommendation, warranty or guaranty by Howard W. Sams & Co., Inc., as to the quality and suitability of such replacement part. The numbers of these parts have been compiled from information furnished to Howard W. Sams & Co., Inc., by the manufacturers of the particular type of replacement part listed."
 "Reproduction or use, without express permission, of editorial or pictorial con-

tent, in any manner, is prohibited. No patent liability is assumed with respect to the use of the information contained herein. Copyright 1948 by Howard W. Sams & Co., Inc., Indianapolis, Indiana, U. S. A. Copyright under International Copyright Union. All rights reserved under Inter-American Copyright Union (1910) by Howard W. Sams & Co., Inc." Printed in U. S. of America

- A10
- 166
- 22
- 25
- 113
- 36
- 161
- 72
- 160
- 4
- 173
- A5
- A11
- 153
- 162
- 3
- 152
- A13
- A7
- 171
- 163
- 2
- A45
- 172
- A49
- A47
- A44
- A48
- A50

- 154
- A3
- 8
- 7
- A17

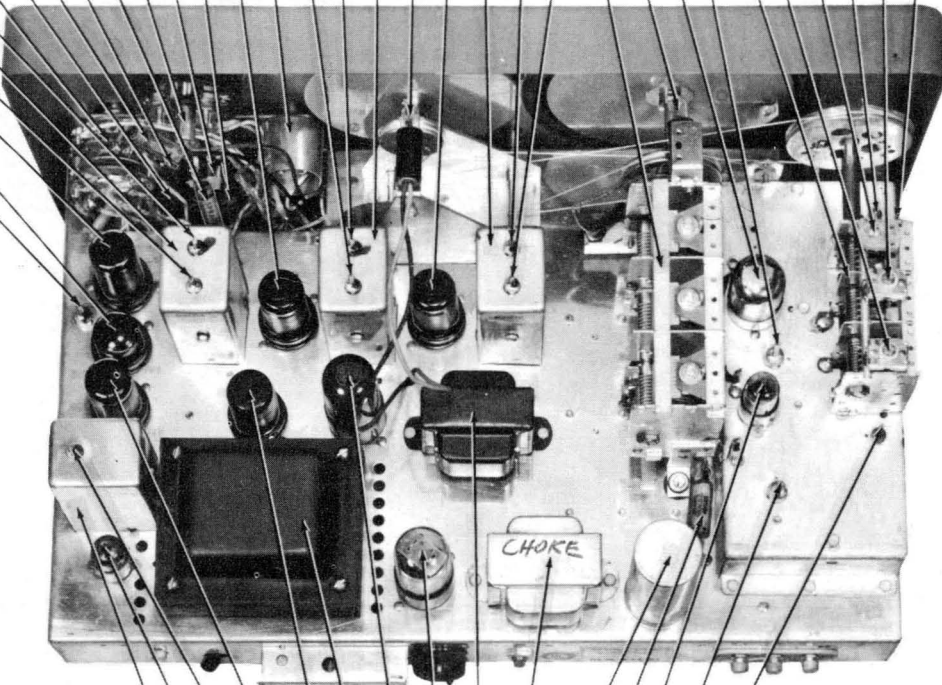

- 155
- 6
- A8
- 5
- 9
- 131
- 10
- 11
- 133
- 132
- 12
- 37
- 1
- A46
- A52

1000 Ω
1000 Ω

- 39
- 97
- 127
- 31
- 126
- 141
- 73
- 135
- 140
- 134
- 142
- 130
- 136
- 82
- 124
- 137
- 143
- 80
- 79
- 77
- 78
- 70
- 69

A4

- 121
- 110
- 159
- A
- 109
- B
- A1
- 49
- C
- 114

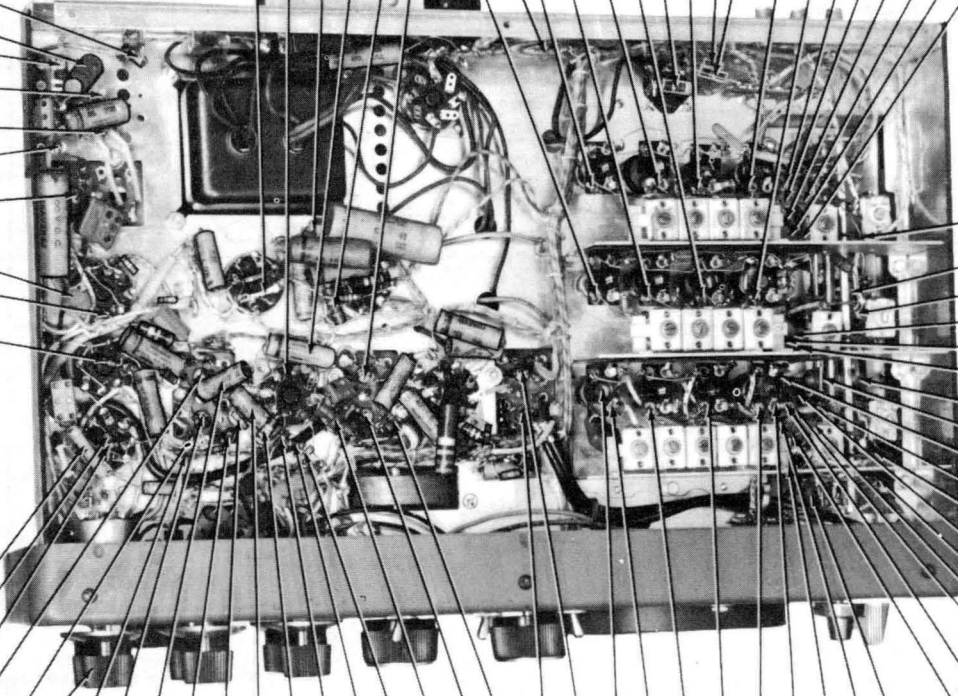

- 139
- 68
- 66
- 59
- 67
- 144
- 145
- 89
- 87
- 85
- 151
- 61
- 150
- 84
- 62

- 42
- 46
- 119
- A2
- 112
- A16
- 117
- A9
- 29
- 111
- 102
- 30
- 101
- 99
- 98
- 100
- 158
- A14
- 96
- A12
- A6
- A25
- 147
- 146
- 148
- 149
- 60
- 86
- 83
- 103
- 58
- 88

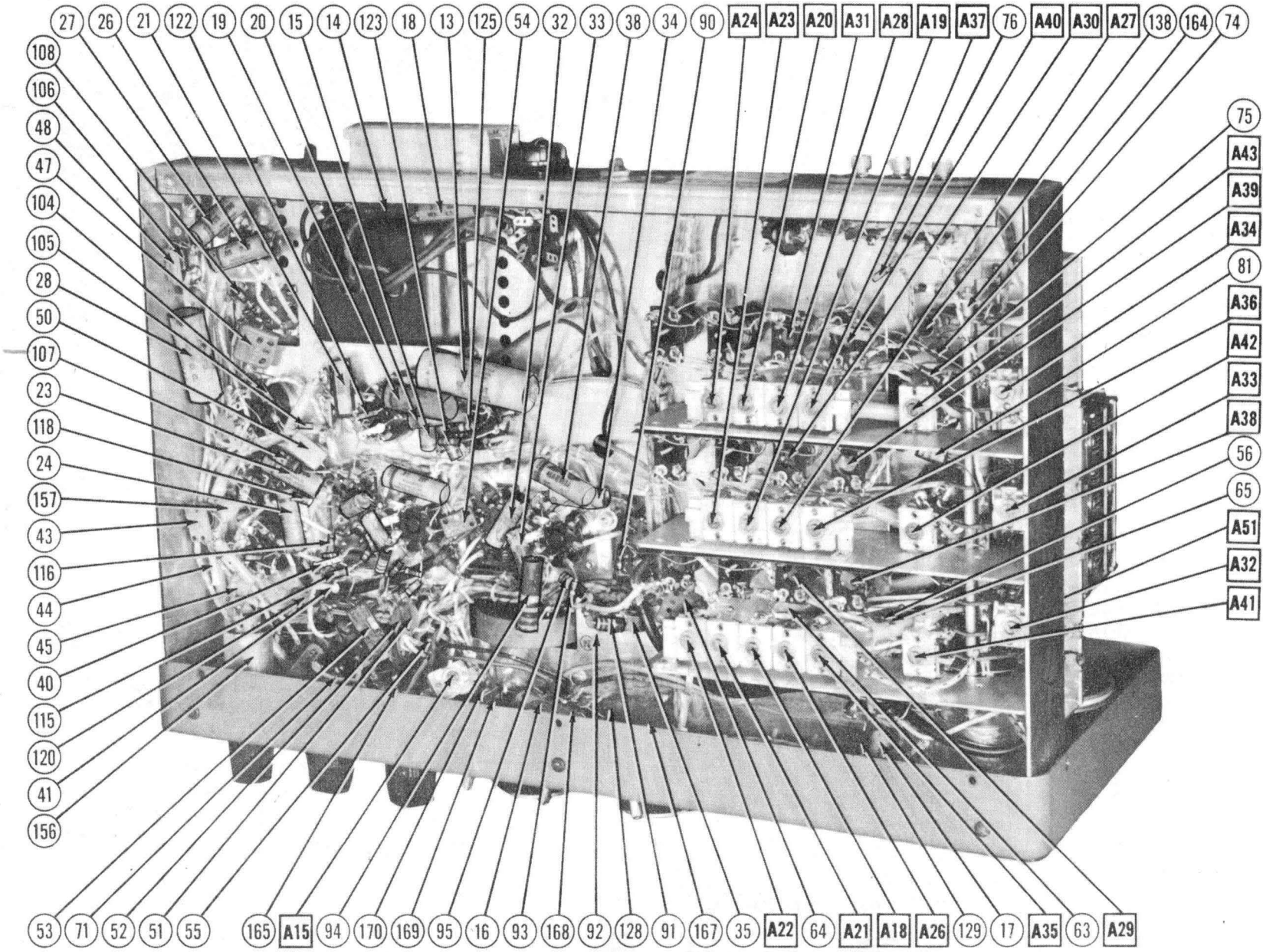

HALLCRAFTERS MODEL
SX-43
PAGE 3

PARTS LIST AND DESCRIPTIONS

TUBES (SYLVANIA or Equivalent)

ITEM No.	USE	REPLACEMENT DATA		RMA BASE TYPE	INSTALLATION NOTES
		HALLICRAFTERS PART No.	STANDARD REPLACEMENT		
1	RF Amp.	6BA6	6BA6	7BK	
2	Converter	7F8	7F8	8BW	
3	1st IF Amp.	6SQ7	6SQ7	8BK	
4	2nd IF-2nd Mixer	6SH7	6SH7	8BK	
5	3rd IF Amp.	6SH7	6SH7	8BK	
6	FM Ratio Det.	6AL5	6AL5	6BT	
7	AM Det.	6H6	6H6	7Q	
8	BFO-2nd Osc.	6J5	6J5	6Q	
9	AF Amp.	6SQ7	6SQ7	8Q	
10	Power Output	6V6GT	6V6GT	7AC	
11	Rectifier	5Y3GT	5Y3GT	5T	

CAPACITORS

Capacity values given in the rating column are in mfd. for Electrolytic and Paper Capacitors, and in mmfd. for Mica and Ceramic Capacitors.

ITEM No.	RATING		REPLACEMENT DATA					IDENTIFICATION CODES AND INSTALLATION NOTES
	CAP.	VOLT	HALLICRAFTERS PART No.	AEROVOX PART No.	CORNELL-DUBILIER PART No.	SOLAR PART No.	SPRAGUE PART No.	
12A	60	450	45B113	AF444J	JP222246	DY-3x20-450	EL-420	▲ Filter
B	20	450						■
C	20	400						▲
13	10	25	42A033	PRS450-40	BR2045	M-40-450	UT-20	Cathode Bypass
14	.01	400	46AW103J	484-01	DT4S1	MPH-4-01	TC-11	Line Filter
15	.005	600	46AY502J	684-005	DT6D5	ST-6-005	TC-25	Tone Compensation
16	.02	600	46AY203J	684-02	DT6S2	ST-6-02	TC-12	" "
17	.005	600	46AY502J	684-005	DT6D5	ST-6-005	TC-25	" "
18	.1	200	46AU104J	484-.1	DT2P1	ST-2-1	TC-1	Filament Bypass
19	.05	600	46AY503J	684-05	DT6S5	ST-6-05	TC-15	Output Screen Bypass
20	.02	400	46AW203J	484-02	DT4S2	ST-4-02	TC-12	Audio Coupling
21	.005	400	46AW502J	484-005	DT4D5	ST-6-005	TC-25	" "
22	.02	400	46AW203J	484-02	DT4S2	ST-4-02	TC-12	" "
23	.05	200	46AU503J	484-05	DT2S5	ST-4-05	TC-15	AVC Filter
24	.02	400	46AW203J	484-02	DT2S2	ST-4-02	TC-12	Audio Coupling
25	.01	400	46AW103J	484-01	DT4S1	ST-4-01	TC-11	AVC Filter
26	.05	200	46AU503J	484-05	DT4S5	ST-4-05	TC-15	Diode Load Cap.
27	.05	200	46AU503J	484-05	DT2S5	ST-4-05	TC-15	" "
28	.25	400	46AU254J	484-.25	DT2P25	ST-4-25	TC-2	3rd IF Screen Bypass
29	.01	400	46AW103J	484-01	DT4S1	ST-4-01	TC-11	2nd IF Plate Decoupling
30	.01	400	46AW103J	484-01	DT4S1	ST-4-01	TC-11	2nd IF Screen Bypass
31	.05	200	46AU503J	484-05	DT2S5	ST-4-05	TC-15	2nd IF Cathode Bypass
32	.01	400	46AW103J	484-01	DT4S1	ST-4-01	TC-11	1st IF Plate Decoupling
33	.01	400	46AW103J	484-01	DT4S1	ST-4-01	TC-11	1st IF Screen Bypass
34	.01	400	46AW103J	484-01	DT4S1	ST-4-01	TC-11	AVC Filter
35	.01	400	46AW103J	484-01	DT4S1	ST-4-01	TC-11	Conv. Plate Decoupling
36	.02	400	46AW203J	484-02	DT4S2	ST-4-02	TC-12	RF Gain Control Bypass
37	.05	200	46AU503J	484-05	DT2S5	ST-4-05	TC-15	AVC Filter
38	.05	200	46AU503J	484-05	DT2S5	ST-4-05	TC-15	1st IF Cathode Bypass
39	100	500	CC25UK101K	1468-0001	5W5T1	MO.5-31	1FM-31	AF Plate Bypass-Cer.
40	100	500	CC25UK101K	1468-0001	5W5T1	MO.5-31	1FM-31	Diode RF Filter-Cer.
41	100	500	CC25UK101K	1468-0001	5W5T1	MO.5-31	1FM-31	" "
42	10000	350	47A167	684-01	DT6S1	ST-6-01	TC-11	BFO Coupling - Cer.
43	270	500	CM20A271J	1468-0003	5W5T3	MO.5-33	1FM-33	Fixed Trimmer
44	100	500	CC25UK101K	1468-0001	5W5T1	MO.5-31	1FM-31	BFO Grid Cap.-Cer.
45	470	500	CM20A471J	1468-0005	5W5T5	MO.5-35	1FM-35	Fixed Trimmer
46	2	500	47A160-4					2nd Osc. Coupling-Cer.
47	1000	500	CM20A102K	1467-001	1W5D1	MW.5-21	1FM-21	RF Bypass
48	1000	500	CM20A102K	1467-001	1W5D1	MW.5-21	1FM-21	De-emphasis
49	5000	450	47A163	684-005	1D5D5	MW.5-25	1FM-25	3rd IF Decoupling-Cer.
50	220	500	CM20A221K	1468-00025	5W5T25	MO.5-325	1FM-325	IF Coupling
51	5000	400	47A163	684-005	1D5D5	MW.5-25	1FM-25	RF Gain Control Byp.-Cer.
52	5000	450	46AW502J	684-005	1D5D5	MW.5-25	1FM-25	" "
53	820	500	CM25A821K	1479-0008	1W5T8	MW.5-38	1FM-38	Diode RF Filter
54	22	500	CM20A220K	1468-00025	5W5Q25	MO.5-425	MS-42	RF Coupling
55	15	500	CC20UK150K	1468-00025	5W5Q25	MO.5-425	MS-42	Fixed Trimmer-Cer.
56	22	500	CM20A220K	1467-001	1W5D15	MW.5-215	1FM-215	Conv. Plate Bypass
57	1500	350	47A161					RF Byp. Power Supply-Cer.
58	10000	350	47A167	484-01	DT6S1	ST-6-01	TC-11	See Note
59	220	500	CM20B221K	1468-00025	5W5T25	MO.5-325	1FM-325	Conv. Cathode Byp.-Cer.
								RF Coupling

PARTS LIST AND DESCRIPTIONS (Continued)

RESISTORS

ITEM No.	RATING		REPLACEMENT DATA		IDENTIFICATION CODES
	RESISTANCE	WATTS	HALLICRAFTERS PART No.	IRC PART No.	
112	2.2 Meg.	1/2	RC20AE225K	BTS-2.2 Meg	Red-Red-Grn. AVC Network
113	150Ω	1/2	RC20AE151K		Br.-Grn.-Br. AVC Shunt
114	2.7 Meg.	1/2		BTS-2.7 Meg	Red-Vi.-Grn. Noise Limiter Load
115	82KΩ	1/2	RC20AE823K	BTS-82K	Gray-Red-Or. Diode Load
116	1 Meg.	1/2	RC20AE105K	BTS-1 Meg.	Br.-Blk.-Grn. Noise Limiter Bias Network
117	250KΩ	1/2	23BX2543	BTS-270K	Red-Grn.-Yl. Diode Load
118	1 Meg.	1/2	RC20AE105K	BTS-1 Meg.	Br.-Blk.-Grn. Noise Limiter Bias Network
119	47KΩ	1/2	RC20AE473K	BTS-47K	Yl.-Vi.-Or. BFO Grid
120	15KΩ	1/2	RC30AE153K	BTA-15K	Br.-Grn.-Or. BFO Plate
121	470KΩ	1/2	RC20AE474K	BTS-470K	Yl.-Vi.-Yl. Phono Shunt
122	15 Meg.	1/2	RC20AE156K	BTS-15 Meg.	Br.-Grn.-Blue AF Grid
123	220KΩ	1/2	RC20AE224K	BTS-220K	Red-Red-Yl. AF Plate Load
124	1000Ω	1/2	RC30AE102K	BTA-1000	Br.-Blk.-Red Output Screen Dropping
125	470KΩ	1/2	RC20AE474K	BTS-470K	Yl.-Vi.-Yl. Output Grid
126	270Ω	1/2	RC30AE271K	BW-1-270	Red-Vi.-Br. Output Cathode
127	33KΩ	1/2	RC30AE333K	BTA-33K	Or.-Or.-Or. Tone Comp.
128	1000Ω	1/2	RC30AE102K	BTA-1000	Br.-Blk.-Red " "
129	470Ω	1/2	RC30AE471K	BTA-470	Yl.-Vi.-Br. Head phones shunt
130	4700Ω	1/2	RC30AE472K	BTA-4700	Yl.-Vi.-Red Filter

TRANSFORMER (POWER)

ITEM No.	RATING				REPLACEMENT DATA			
	PRI.	SEC. 1	SEC. 2	SEC. 3	HALLICRAFTERS PART No.	STANCOR PART No.	THORDARSON PART No.	MERIT PART No.
131	117V AC	530V CT	5.2V AC	6.3V AC	52C143	P-6313		P-2953#
	@ .74A	.10A DC	@ 2.0A	@ 4.0A				

*Add series resistor to reduce plate voltage.

FILTER CHOKE

ITEM No.	RATINGS			REPLACEMENT DATA				INSTALLATION NOTES
	TOTAL DIRECT CURRENT	D. C. RESISTANCE	INDUCTANCE (0 CURRENT 1000 ¹)	HALLICRAFT. PART No.	STANCOR PART No.	THORDARSON PART No.	MERIT PART No.	
132	.052A DC	290Ω	17 Henries	56B067	C-1709	T20C53	C-29901	†Drill one new mounting hole.

TRANSFORMER (OUTPUT)

ITEM No.	RATING				REPLACEMENT DATA				INSTALLATION NOTES
	IMPEDANCE		DC RES.		HALLICRAFT. PART No.	STANCOR PART No.	THORDARSON PART No.	MERIT PART No.	
133	4000Ω	5000Ω	360Ω	310Ω	55B095				
		500Ω		36Ω					

R F COILS

ITEM No.	USE	DC RES.		REPLACEMENT DATA	
		PRI.	SEC.	HALLICRAFTERS PART No.	MEISSNER PART No.
134	Ant. Coil 1	26Ω	5Ω	51B928	
135	" " 2	1.5Ω	.3Ω	51B927	
136	" " 3	.2Ω	.1Ω	51B926	
137	" " 4	.1Ω	Ω	51B925	
138	" " 5	Ω	Ω	51B924	
139	" " 6	Ω	Ω	51B923	
140	RF Coil 1	.3Ω	.1Ω	51B934	
141	" " 2	.2Ω	.1Ω	51B933	
142	" " 3	.6Ω	.1Ω	51B932	
143	" " 4	.2Ω	Ω	51B931	
144	" " 5	Ω	Ω	51B930	
145	" " 6	Ω	Ω	51B929	
146	Ω	1	5.3Ω	51B936	
147	" " 2	1.6Ω	.1Ω	51B938	
148	" " 3	.4Ω	.1Ω	51B937	

PARTS LIST AND DESCRIPTIONS (Continued)

CAPACITORS

Capacity values given in the rating column are in mfd. for Electrolytic and Paper Capacitors, and in mmfd. for Mica and Ceramic Capacitors.

ITEM No.	RATING		REPLACEMENT DATA					IDENTIFICATION CODES AND INSTALLATION NOTES
	CAP.	VOLT	HALLICRAFTER PART No.	AEROVOX PART No.	CORNELL-DUBILIER PART No.	SOLAR PART No.	SPRAGUE PART No.	
60	Temp.	Comp.	44A158					
61	51	500	CC20UK510K	1468-00005	5W5Q5	MO.5-45	1FM-45	Osc. Plate Bypass
62	100	500	CC25UK101K	1468-00001	5W5T1	MO.5-31	1FM-31	Osc. Grid Cap.-Cer.
63	3900	500	CM35A392J					Osc. Coupling-Cer.
64	1500	500	CM30A152J	1464-0015	1R5D15	MW.5-215		Fixed Pad.
65	15	500	CC20UK150K				MS-415	Fixed Trimmer-Cer.
66	25	500	47A141	1468-000025	5W5Q25	MO.5-425	MS-425	RF Coupling-Cer.
67	25	500	47A141	1468-000025	5W5Q25	MO.5-425	MS-425	" "
68	1500	350	47A61	1467-0015	1W5D15	MW.5-215	1FM-215	RF Decoupling-Cer.
69	1500	350	47A61	1467-0015	1W5D15	MW.5-215	1FM-215	RF Screen Bypass-Cer.
70	10000	350	47A167	684-01	DT681	ST-6-01	TC-11	RF Cathode Bypass-Cer.

Note-Not used in some models.

CONTROLS

ITEM No.	RATING		REPLACEMENT DATA			INSTALLATION NOTES
	RESISTANCE	WATTS	HALLICRAFTER PART No.	IRC PART No.	CLAROSTAT PART No.	
71A	2 Meg.	1/2	25B601	D13-139	M-66-Z	Volume Control
B	Shaft		Not Req.	A	Not Req.	Attach to 71A per instructions
C	Switch		" "	41	SW-A	" "
72A	10KΩ	1/2	25B577	D16-116	M-30-V	Sensitivity Control
B	Shaft		Not Req.	A	Not Req.	Attach to 72A per instructions
73	500Ω	1	25A569	W-500	43-500	"S" Meter Control

RESISTORS

ITEM No.	RATING		REPLACEMENT DATA		IDENTIFICATION CODES
	RESISTANCE	WATTS	HALLICRAFTER PART No.	IRC PART No.	
74	47Ω	1/2	RC20AE470K		Y1.-Vi.-Blk. Ant. Loading
75	27Ω	1/2	RC20AE270K		Red-Vi.-Blk. Parasitic Suppressor
76	1 Meg.	1/2	RC20AE105K	BTS-1 Meg.	Br.-Blk.-Grn. AVC Network
77	5.6Ω	1/2	23A011		Grn.-Blue-Gold Par. Suppressor
78	68Ω	1/2	RC20AE680K		Blue-Gray-Blk. RF Cathode
79	27KΩ	1	RC30AE273K	BTA-27K	Red-Vi.-Or. Bleeder
80	15KΩ	2	RC40AE153K	BT-2-15K	Br.-Grn.-Or. RF Screen Dropping
81	5.6Ω	1/2	23A011		Grn.-Blue-Gold Par. Suppressor
82	1000Ω	1/2	RC20AE102K	BTS-1000	Br.-Blk.-Red Decoupling
83	47Ω	1/2	RC20AE470K		Y1.-Vi.-Blk. Par. Suppressor
84	33Ω	1/2	RC20AE330K		Or.-Or.-Blk. " "
85	22KΩ	1/2	RC20AE223K	BTS-22K	Red-Red-Or. Osc. Grid
86	10KΩ	1/2	RC30AE103K	BTA-10K	Br.-Blk.-Or. Osc. Plate Load
87	2.2 Meg.	1/2	RC20AE225K	BTS-2.2 Meg	Red-Red-Grn. Conv. Grid
88	1000Ω	1/2	RC20AE102K	BTS-1000	Br.-Blk.-Red Conv. Cathode
89	15Ω	1/2	RC20AE150K		Br.-Grn.-Blk. Par. Suppressor
90	10Ω	1/2	RC20AE100K		Br.-Blk.-Blk. " "
91	47KΩ	1/2	RC30AE473K	BTA-47K	Y1.-Vi.-Or. Conv. Plate Dropping
92	22KΩ	1/2	RC20AE223K	BTS-22K	Red-Red-Or. Bleeder
93	82Ω	1/2	RC20AE820K		Gray-Red-Blk. 1st IF Cathode
94	15KΩ	1/2	RC40AE153K	BT-2-15K	Br.-Grn.-Or. 1st IF Screen
95	27KΩ	1/2	RC30AE273K	BTA-27K	Red-Vi.-Or. Bleeder
96	3300Ω	1/2	RC20AE332K	BTS-3300	Or.-Or.-Red 1st IF Plate Decoupling
97	1 Meg.	1/2	RC20AE105K	BTS-1 Meg.	Br.-Blk.-Grn. 2nd IF Grid
98	82Ω	1/2	RC20AE820K		Gray-Red-Blk. Series "S" Meter
99	150Ω	1/2	RC20AE151K		Br.-Grn.-Br. 2nd IF Cathode
100	680Ω	1/2	RC20AE681K	BTS-680	Blue-Gray-Br. 2nd IF Cathode
101	33KΩ	1/2	RC30AE333K	BTA-33K	Or.-Or.-Or. 2nd IF Screen
102	3300Ω	1/2	RC20AE332K	BTS-3300	Or.-Or.-Red 2nd IF Plate Decoupl.
103	1000Ω	1/2	RC20AE102K	BTS-1000	Br.-Blk.-Red 2nd IF Cathode
104	220KΩ	1/2	RC20AE224K	BTS-220K	Red-Red-Y1. 3rd IF Grid
105	1 Meg.	1/2	RC20AE105K	BTS-1 Meg.	Br.-Blk.-Grn. AVC Network
106	150Ω	1/2	RC20AE151K		Br.-Grn.-Br. Par. Suppressor
107	100KΩ	1/2	RC30AE104K	BTA-100K	Br.-Blk.-Y1. 3rd IF Decoupling
108	100KΩ	1/2	RC20AE104K	BTS-100K	Br.-Blk.-Y1. De-emphasis
109	100KΩ	1/2	RC20AE104K	BTS-100K	Br.-Blk.-Y1. Ratio Det. Diode Load
110	100KΩ	1/2	RC20AE104K	BTS-100K	Br.-Blk.-Y1. " "
111	100KΩ	1/2	RC20AE104K	BTS-100K	Br.-Blk.-Y1. AM Diode Filter

PARTS LIST AND DESCRIPTIONS (Continued)

R F COILS

ITEM No.	USE	DC RES.		REPLACEMENT DATA	
		PRI.	SEC.	HALLICRAFTER PART No.	MEISSNER PART No.
149	Osc. Coil 4	.1Ω	0Ω	51B936	
150	" " 5	0Ω	0Ω	51B935	
151	" " 6	0Ω	0Ω	51B941	
152A	1st IF AM	2.5Ω	6.8Ω*	50C212	*Includes both secondaries.
B	" FM	1.2Ω			
153A	2nd IF AM	1Ω*	7.8Ω	50C213	*Includes both primaries.
B	" FM		.1Ω		
154A	3rd IF AM	9.6Ω*	6Ω	50C214	
B	" FM		.7Ω		
155	FM Det. Trans.	2Ω	1.2Ω	50C208	
156	Am BFO Coil		14Ω	54B033-1	
157	Ind. Osc. "		0Ω	51B984	
158	RF Choke		3.2Ω	53A108	
159	" "		.2Ω	53B009	
160	" "		9.5Ω	53A107	

DIAL LIGHT

ITEM No.	BASE TYPE	VOLTS	AMPS.	BEAD COLOR	REPLACEMENT DATA		INSTALLATION NOTES
					HALLICRAFTER PART No.		
161	Bayonet	6-8	0.15	Brown	39A004		Type 47
162-163	"	"	0.25	Blue			Type 44

MISCELLANEOUS

ITEM No.	PART NAME	HALLICRAFTERS PART No.	NOTES
164	Switch	60C261	Band
165	"	60B263	Selectivity
166	"	60B262	Reception
167	"	60A138	Tone
168	"	60A138	Standby-Receive
169	"	60A138	Noise Limiter
170	Crystal	19A123	455KC
171	3 Gang Var. Cap	48C174	(15-475MFD) Each section (AM)
172	"	48C173	(Bandspread-FM)
173	Phasing Control Capacitor	48A182	
	Trimmer	44A047	A15
	Trimmer Strip Assby.	44B197	A18, A21, A22, A26, A35
	"	44B199	A19, A23, A27, A36
	"	44B199	A20, A24, A28, A37
	"	44A047	A32, A33, A34, A48, A49
	"	44A200	A41, A42, A43
	"	44A115	A47
	Meter	82B125	Carrier Level

REPLACING LAMPS

The two dial lamps and meter lamp are accessible through the hinged cabinet cover. Remove two screws holding the metal light shield to expose the dial lamps. Replace these with 6-3V. 250MA. GE. #44 (Blue bead) or equivalent. The carrier level meter lamp is made accessible by removing the four screws holding the protective cover located directly behind the meter. Replace this lamp with a 6-8 V. 150 MA. #47 (Brown bead) or equivalent. Do not use a 250 MA. lamp in the meter housing as the excessive heat will discolor the meter scale.

OR 6A45

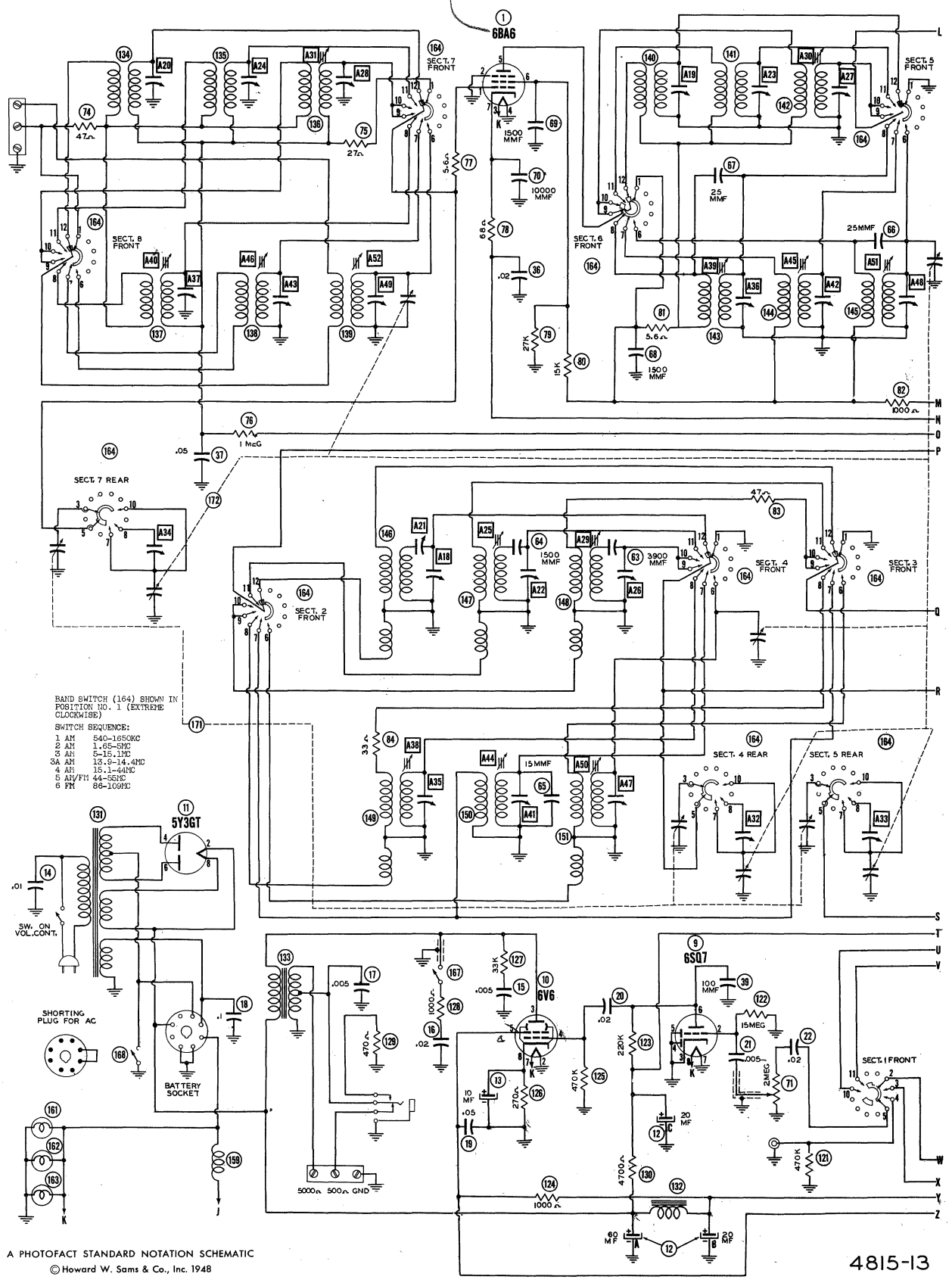

BAND SWITCH (164) SHOWN IN POSITION NO. 1 (EXTREME CLOCKWISE)

SWITCH SEQUENCE:

- 1 AM 540-1650KC
- 2 AM 1.65-2MC
- 3 AM 6-16.1MC
- 3A AM 13.9-14.4MC
- 4 AM 16.1-44MC
- 5 AM/FM 44-50MC
- 6 FM 88-109MC

W.D. WRONG at 6V6 (Pin 5 is +)

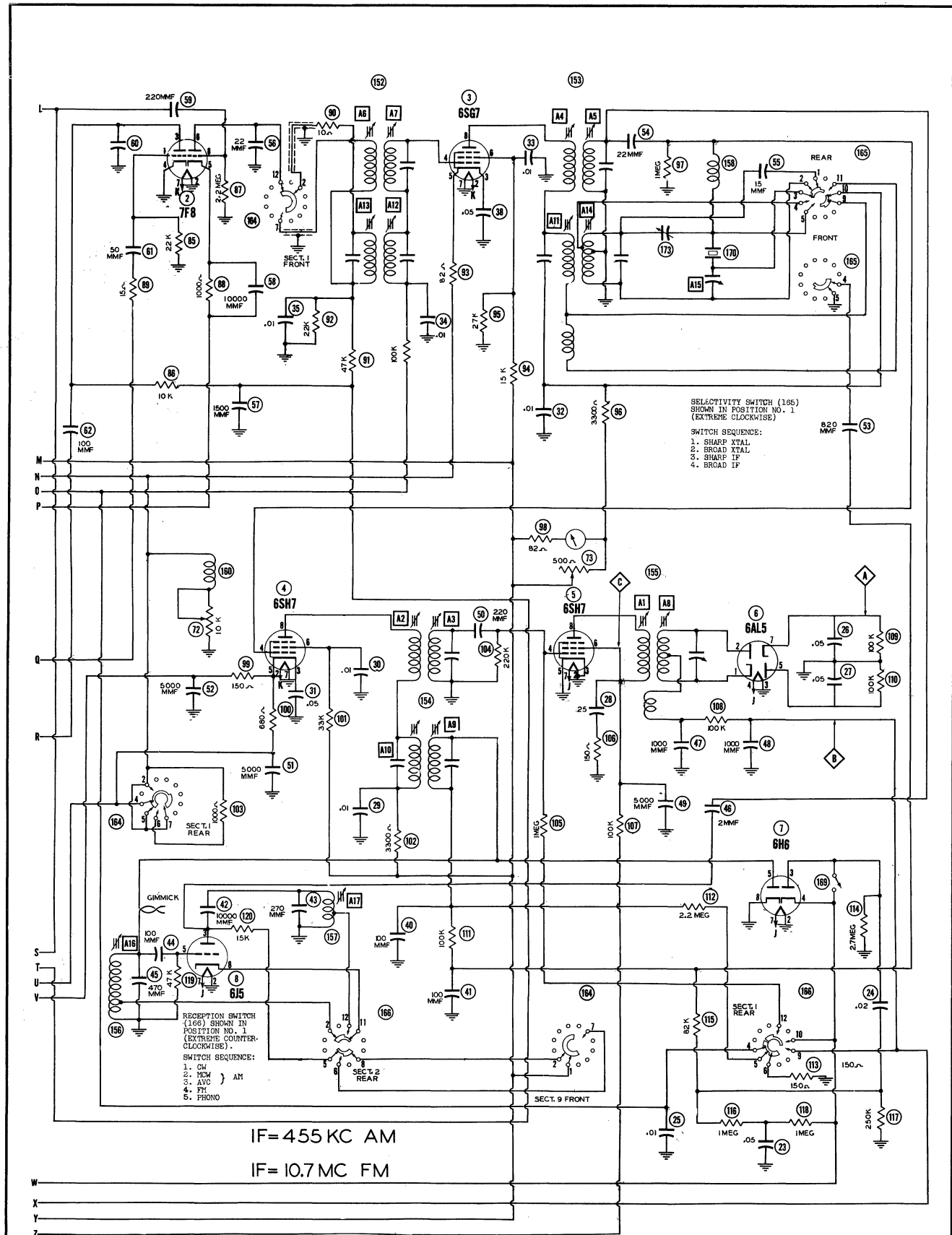

A PHOTOFAC STANDARD NOTATION SCHEMATIC
© Howard W. Sams & Co., Inc. 1948

4815-13

VOLTAGE AND RESISTANCE READINGS TAKEN IN BROADCAST POSITION.

VOLTAGE READINGS

Item	Tube	Pin 1	Pin 2	Pin 3	Pin 4	Pin 5	Pin 6	Pin 7	Pin 8
1	6BA6	0V.	0V.	6.3VAC	0V.	250VDC	120VDC	8VDC	-
2	7F8	-2VDC‡	0V.	180VDC	0V.	.6VDC	65VDC	6.3VAC	-.5VDC
3	6SG7	0V.	6.3VAC	1.6VDC	0V.	1.6VDC	155VDC	0V.	260VDC
4	6SH7	0V.	6.3VAC	4.6VDC	0V.	4.6VDC	225VDC	0V.	270VDC
5	6SH7‡	0V.	0V.	0V.	-.4VDC	0V.	35VDC	6.3VAC	35VDC
6	6AL5‡	0V.	0V.	0V.	6.3VAC	.4VDC	0V.	-.4VDC	-
7	6H6	0V.	0V.	0V.	0V.	-.5VDC	0V.	6.3VAC	0V.
8	6J5**	0V.	0V.	160VDC	0V.	-6.4VDC‡	0V.	6.3VAC	0V.
9	6SQ7	0V.	-.4VDC	0V.	0V.	0V.	120VDC	0V.	6.3VAC
10	6V6GT	0V.	0V.	280VDC	270VDC	0V.	240VDC	6.3VAC	12.5VDC
11	5Y3GT	0V.	290VDC	0V.	265VAC	0V.	265VAC	0V.	290VDC

‡ TAKEN WITH VACUUM TUBE VOLTMETER.

RESISTANCE READINGS

Item	Tube	Pin 1	Pin 2	Pin 3	Pin 4	Pin 5	Pin 6	Pin 7	Pin 8
1	6BA6	3.6 Meg.	0Ω	.1Ω	0Ω	20KΩ	15KΩ	78Ω	-
2	7F8	22KΩ	0Ω	30KΩ	0Ω	1KΩ	20KΩ	.1Ω	2.2 Meg.
3	6SG7	0Ω	.1Ω	92Ω	2.6 Meg.	92Ω	15KΩ	0Ω	24KΩ
4	6SH7	0Ω	.1Ω	690Ω	5Ω	690Ω	50KΩ	0Ω	24KΩ
5	6SH7‡	0Ω	0Ω	0Ω	220KΩ	0Ω	120KΩ	.1Ω	120KΩ
6	6AL5‡	INF.	INF.	0Ω	.1Ω	100KΩ	0Ω	100KΩ	-
7	6H6	0Ω	0Ω	1.3 Meg.	1.3 Meg.	400KΩ	0Ω	.1Ω	0Ω
8	6J5**	0Ω	0Ω	25KΩ	0Ω	47KΩ	0Ω	.1Ω	4Ω
9	6SQ7	0Ω	15 Meg.	0Ω	0Ω	0Ω	240KΩ	0Ω	.1Ω
10	6V6GT	0Ω	0Ω	20KΩ	21KΩ	470KΩ	20KΩ	.1Ω	280Ω
11	5Y3GT	INF.	20KΩ	INF.	70Ω	INF.	65Ω	INF.	20KΩ

‡ VOLTAGE AND RESISTANCE READINGS TAKEN IN FM POSITION.
RECEIVE-STANDBY SWITCH IN RECEIVE POSITION.
**TAKEN IN CW POSITION. NOISE LIMITER OFF.
SENSITIVITY CONTROL FULL ON.
SELECTIVITY CONTROL FULL ON.
TONE HIGH.

- 1 - DC Voltage measurements are at 20,000 ohms per volt; AC Voltages measured at 1000 ohms per volt.
- 2 - Socket connections are shown as bottom views.
- 3 - Measured values are from socket pin to common negative.
- 4 - Line voltage maintained at 117 volts for voltage readings.
- 5 - Nominal tolerance on component values makes possible a variation of ± 15% in voltage and resistance readings.
- 6 - Volume control at maximum, no signal applied for voltage measurements.

STAGE GAIN MEASUREMENTS

ANTENNA TO RF GRID	2X	600KC
RF GRID TO CONV. GRID	2X	600KC
CONVERSION GAIN	15X	IN 600KC OUT 455KC
INPUT IF TRANSFORMER	1.5X	455KC
1st IF TUBE	175X	455KC
INTER IF TRANS.	.1X	455KC
2nd IF TUBE	200X	455KC
OUTPUT IF TRANS.	.3X	455KC
AUDIO	35X	400 ~
OUTPUT	28X	400 ~

The stage gain measured values listed above are approximate values for an average operative stage, rather than an absolute value. It should be borne in mind that it is possible to introduce so many variables into the measurement operation, such as, type of equipment used for measuring, handling and placement of probes, the accuracy of alignment, etc., that an absolute reading is impractical. AVC is made inoperative by connecting negative (-) 3 volts to the AVC line.

ALIGNMENT INSTRUCTIONS—READ CAREFULLY BEFORE ATTEMPTING ALIGNMENT

Set all controls as follows except where noted otherwise: "Crystal-phasing" to zero, "Sensitivity" at maximum, "Reception" to "AM-MVC", "Selectivity" to "Normal-Sharp", "Volume" at maximum, "CW Pitch" to zero, Tone switch to "High", Standby-Receive switch to "Receive" and Noise Limiter to "Off". Set bandspread tuning cap. fully open at all times with exception of Bands 5 & 6 where it only is used for tuning. Use insulated alignment screwdriver for all adjustments.

10.7 MC IF ALIGNMENT USING AM SIGNAL GENERATOR AND VTVM

DUMMY ANTENNA	SIGNAL GENERATOR COUPLING	SIGNAL GENERATOR FREQUENCY	BAND SWITCH POS.	RADIO DIAL SETTING	CONNECT VTVM	ADJUST	REMARKS
1 Direct	High side to rear stator of center section of bandspread tuning cap.	10.7MC (Unmodulated)	Band "5"	50 on logging scale.	DC probe to Point \diamond . Common to ground.	A1, A2, A3, A4, A5, A6, A7	Turn reception switch to "FM" and adjust for maximum deflection.
2 "	"	"	"	"	DC probe to Point \diamond . Common to ground.	A8	Adjust for zero deflection. Continue with AM alignment in Step 5.

10.7 MC IF ALIGNMENT USING FM SIGNAL GENERATOR AND OSCILLOSCOPE

Use freq. modulated signal with 60 μ modulation and 450KC sweep. Use 120 μ sawtooth voltage in scope for horizontal deflection.

DUMMY ANTENNA	SIGNAL GENERATOR COUPLING	SIGNAL GENERATOR FREQUENCY	BAND SWITCH POS.	RADIO DIAL SETTING	SCOPE CONNECT	ADJUST	REMARKS
1 .05 MFD	High side to Pin 4 (grid) of 6SH7 2nd IF Tube (4). Low side to chassis.	10.7MC (Freq. Mod.)	Band "5"	50 on logging scale.	Vertical input in series with .05 MFD. cap. to Point \diamond . Low side to chassis.	A2, A3	Turn reception switch to FM and adjust for maximum amplitude, symmetry and coincidence of pattern per Fig. 1.
2 .05 MFD	High side to Pin 4 (grid) of 6SG7. Low side to chassis.	"	"	"	"	A4, A5	"
3 .05 MFD	High side to rear stator of center section of bandspread tuning cap.	"	"	"	"	A6, A7	"
4 .05 MFD	High side to Pin 4 (grid) of 6SH7 2nd IF Tube (4). Low side to chassis.	"	"	"	Vertical input to Point \diamond . Ground to chassis.	A1, A8	Alternately adjust A1 for maximum amplitude and A8 for maximum straightness of crossover lines with crossover occurring at center of pattern per Fig. 2. Continue with AM Alignment in Step 5.

AM IF ALIGNMENT

In Steps 5, 6, 7 and 8 set sig. gen. to exact crystal frequency as follows: Set sig. gen. to approximately 455KC. Turn BFO on and set CW pitch for approximately a 1000 μ note. Set selectivity control to "Crystal-Sharp" and tune sig. gen. to weakest of the two response frequencies on either side of zero beat. Adjust "Crystal-Phasing" control for minimum audio output. Retune sig. gen. for maximum output on the opposite side of zero beat.

DUMMY ANTENNA	SIGNAL GENERATOR COUPLING	SIGNAL GENERATOR FREQUENCY	BAND SWITCH POS.	RADIO DIAL SETTING	OUTPUT METER	ADJUST	REMARKS
5 Direct	High side to rear stator of center section of tuning cap. Low side to chassis.	455KC (See pre-alignment notes)	Band "4"	50 on logging scale.	Across voice coil	A9, A10, A11, A12, A13	Turn selectivity switch to normal sharp and adjust A9, A10, A11, A12 and A13 for maximum output.
6 Direct	"	"	"	"	"	A14	Turn selectivity switch to "Crystal-Broad". Adjust A14 for maximum output.
7 Direct	"	"	"	"	"	A15	Turn selectivity switch to "Normal-Sharp". Adjust A15 for maximum output.
8 Direct	"	"	"	"	"	A16	Turn reception switch to "CW". Remove CW pitch control knob and adjust A16 for zero beat. Replace knob with zero at index line. Repeat 10.7 MC IF alignment to insure that they have not been detuned in the process of aligning 455KC IF.
9 Direct	"	10.7MC	Band "5"	"	"	A17	Adjust for maximum output. Tune sig. gen. to 11.61MC. If signal is not heard retune sig. gen. to 10.7 MC and adjust A17 counter-clockwise to next peak. Adjust for maximum output and recheck for image. Reassembly receiver in cabinet.

RF ALIGNMENT

RMA Dummy consists of 200 MMFD cap. in series with 20 microhenry choke with choke shunted by a 400 MMFD cap. in series with a 400 Ω carbon resistor.

DUMMY ANTENNA	SIGNAL GENERATOR COUPLING	SIGNAL GENERATOR FREQUENCY	BAND SWITCH POS.	RADIO DIAL SETTING	OUTPUT METER	ADJUST	REMARKS	
10 RMA Dummy (see prealignment notes)	High side to ant. terminal "A1". Low side to "A2" with "A2" grounded.	1500KC	Band 1	1500KC	Across voice coil	A18, A19, A20	Adjust for maximum output in order given.	
11 "	"	600KC	"	600KC	"	A21	Adjust for maximum output in order given. Repeat Steps 10 & 11 until no further improvement can be made.	
12 "	"	4.5MC	Band 2	4.5MC	"	A22, A23, A24	Adjust for maximum output in order given.	
13 "	"	2MC	"	2MC	"	A25	Adjust for maximum output in order given. Repeat Steps 12 & 13 until no further improvement can be made.	
14 330 Ω carbon res.	"	14MC	Band 3	14MC	"	A26	Adjust for maximum output.	
15 "	"	"	"	"	"	A27, A28	Tune for maximum output. Rock tuning cap. and adjust for maximum output.	
16 "	"	6MC	"	6MC	"	A29	Adjust for maximum output.	
17 "	"	"	"	"	"	A30, A31	Tune for maximum output. Rock tuning cap. and adjust for maximum output. Repeat Steps 14 thru 17 until no further improvement can be made.	
18 "	"	14MC	Band 3A	14MC	Main tuning dial at 20 meter band marker. Bandspread at 14MC.	A32	Adjust for maximum output.	
19 "	"	14.2MC	"	14.2MC	Main tuning dial at 20 meter band marker. Bandspread tuned maximum output.	A33, A34	Rock tuning cap. and adjust for maximum output.	
20 "	"	36MC	Band 4	36MC	"	A35	Adjust for maximum output. Tune sig. gen. to 35.1MC. If signal is not heard, retune sig. gen. to 36MC and close A35 to next peak. Adjust for maximum output and recheck for image.	
21 "	"	"	"	"	"	A36, A37	Tune for maximum output. Rock tuning cap. and adjust for maximum output.	
22 "	"	18MC	"	18MC	"	A38	Adjust for maximum output.	
23 "	"	"	"	"	"	A39, A40	Tune for maximum output. Rock tuning cap. and adjust for maximum output. Repeat Steps 20 thru 23 until no further improvement can be made.	
24 "	"	54MC	Band 5	54MC (On band-spread dial)	"	A41	Adjust for maximum output.	
25 "	"	"	"	"	"	A42, A43	Tune for maximum output. Rock tuning cap. and adjust for maximum output.	
26 "	"	46MC	"	46MC	"	A44	Adjust for maximum output.	
27 "	"	"	"	"	"	A45, A46	Tune for maximum output. Rock tuning cap. and adjust for maximum output. Repeat Steps 24 thru 27 until no further improvement can be made.	
28 "	"	"	"	44.6MC (See remarks)	"	A17	Tune for fourth harmonic of the second oscillator at approx. 44.6MC. If signal is not heard A17 is adjusted to the image frequency and Step 9 must be repeated.	
							CONNECT VTVM	
29 330 Ω carbon res.	High side to ant. terminal "A1". Low side to "A2" with "A2" grounded.	106MC	Band 6	106MC	DC probe to Point \diamond . Common to chassis.	A47	Adjust for maximum deflection.	
30 "	"	"	"	"	"	A48, A49	Tune for maximum deflection. Rock tuning cap. and adjust for maximum deflection.	
31 "	"	89MC	"	89MC	"	A50	Adjust for maximum deflection.	
32 "	"	"	"	"	"	A51, A52	Tune for maximum deflection. Rock tuning cap. and adjust for maximum deflection. Repeat Steps 29 thru 32 until no further improvement can be made.	

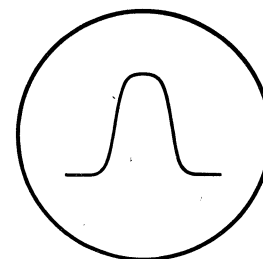

FIG. 1

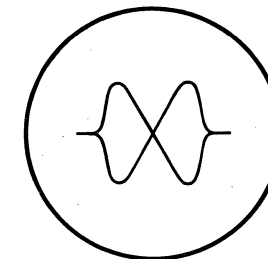

FIG. 2