



OPERATING AND SERVICE INSTRUCTIONS

RADIO RECEIVER
MODEL SX-88



69-1274

HALLICRAFTERS SX-88 RECEIVER

SECTION 1.

GENERAL DESCRIPTION

The Hallicrafters SX-88 represents the ultimate in precision communications equipment. This superb twenty tube communications receiver contains virtually every feature essential for top performance, operating ease, and dependability. It offers continuous coverage from 535 kc to 33 mc and provides for the reception of AM phone, single-sideband phone, and CW signals over its entire tuning range. Electrical bandspread, calibrated for the 160, 80, 40, 20, 15, 11, and 10 meter amateur bands, provides for fine tuning on bands 2 through 6. Band changing is accomplished from the front panel of the receiver, without the use of plug-in coils.

The receiver employs dual conversion on all six bands. As a result, images are practically non-existent, rejection varying between 60 and 120 db, depending on the band. Its 3 stage 50 kc second IF with 8 tuned circuits provides "razor sharp" selectivity ... selectivity greater than most crystal circuits because of the extreme steepness of its selectivity curve. Receiver selectivity is variable in six steps from 250 cycles to 10 kc at the "nose" and 850 cycles to 24 kc at the "skirt".

Two tuned r-f stages on all bands except the broadcast band where one stage is adequate, assures maximum sensitivity and a high signal-to-noise ratio for outstanding reception of weak signals. An antenna trimmer, adjustable from the front panel, permits peaking of the 1st r-f stage to compensate for loading effects of various antennas. Receiver sensitivity for a 10 to 1 signal-to-noise ratio measures 1 microvolt on bands 2 through 6 and 10 microvolts on band 1. A manual sensitivity control prevents overloading on strong signals.

Outstanding frequency stability is achieved by means of ceramic coil forms in the oscillator section, temperature compensation, voltage and current regulation in the 1st conversion oscillator, and the use of a crystal controlled 2nd conversion oscillator.

Tuning is accomplished by a precision anti-backlash gear-train mechanism to insure extremely close calibration and accurate resetability. The ratio of each tuning control to its associated tuning dial is 24 to 1, i.e., 24 complete revolutions are made by the control while the dial makes one complete hand coverage. A logging scale on each dial, calibrated from 0 to 24, indicates the revolutions made by the control. Since the metal skirt of each control is calibrated from 0 to 100, this system of tuning makes it possible to divide each frequency band on the main and handsread tuning dials into 2400 readable settings. A lock on each tuning dial provides positive locking action without affecting its frequency setting. Smooth flywheel tuning assures maximum traverse speed and operating ease.

A built-in 100 kc crystal calibrator provides marker signals at every 100 kc on the dial for checking the calibration accuracy. Any calibration adjustment required can be made from the front panel, by means of the adjustable dial pointers. A trimmer capacitor, accessible from the top of the chassis, permits adjustment of the calibrating crystal to exactly 100 kc by comparison with the frequencies transmitted by station WWV.

The amplified and delayed AVC circuit in the receiver functions on both AM and CW signals to keep the output level of the receiver constant regardless of input-signal variations. This type of AVC circuit is advantageous in that it provides excellent control over a wide range of signal strengths and yet maintains full receiver sensitivity on weak signals.

An automatic series noise limiter circuit, controlled by a switch on the front panel, eliminates interference from electrical equipment and other sources of pulse type noise such as ignition noise.

A tuned buffer amplifier stage isolates the beat frequency oscillator from the detector and provides for two levels of injection, low level injection for CW reception and high level injection for single-side band reception. A three-position toggle switch on the front panel permits selection of either level, and also turns the beat oscillator off for AM reception. The frequency of the beat oscillator is controlled by the Pitch control on the front panel which varies the audible beat note from zero to plus or minus 2500 cycles.

An "S" meter is used when receiving AM signals to indicate the accuracy of tuning and the relative strength of received signals. The meter is calibrated in microvolts, "S" units from 1 to 9, and in decibels above S-9 to +40 db.

The Receive-Standby switch on the front panel silences the receiver but leaves the power on to provide instant reception between transmission periods. Provision has also been made in the receiver for remote receive-standby control, and for transmitter control with the standby switch. An auxiliary sensitivity control, located on the top of the chassis, is switched in the circuit when the receiver is in the "standby" position to permit monitoring of your transmitter signal. A neon lamp, connected across the secondary of the antenna coil, protects the receiver against possible damage from excessive r-f voltage at the antenna terminals during transmission. Protection is provided for terminal voltages up to 50 volts.

A push-pull 6V6 audio output stage with inverse feedback delivers 10 watts of audio power. Audio output connections include terminals for 3.2 and 8 ohm speakers as well as a 500/600-ohm line or speaker output. A front panel jack for headphones is also provided, and the speaker is automatically disabled when the headphones are plugged in. The response of the audio amplifying system is essentially flat from 20 to 20,000 cycles. A 5-position full range tone control provides responses for normal, communications, and full fidelity reception.

The SX-88 operates from a 105-125 volt, 50-60 cycle AC power source. The universal model, the SX-88U, operates from 25-60 cycle AC sources at voltages ranging from 100 to 250 volts. Both models also have provisions for operation from an external power supply or batteries for emergency service in areas where AC power is not available.

This receiver is certified by the FCDA under Specification M6-1, Item #R12.

SECTION 2. INSTALLATION

2-1. UNPACKING

After unpacking the receiver, examine it closely for damage which may have occurred in transit. Should any sign of damage be apparent, file a claim immediately with the carrier stating the extent of damage. Carefully check all shipping labels and tags for instructions before removing or destroying them.

CAUTION

When removing the receiver from the carton be extremely careful not to place any strain on the tuning knobs. Failure to observe this precaution may result in serious damage to the precision tuning mechanism.

2-2. LOCATION

The receiver may be placed in any location that will permit free air circulation through the ventilation holes and openings in the cabinet. Avoid excessively warm locations such as those near radiators and heating vents. The external speaker may be located in any convenient position although it is recommended that it not be placed on top of the receiver for reasons of ventilation.

If rack mounting is desired, the receiver may be removed from the cabinet by removing the two screws at each side of the front panel, the four screws at bottom of the cabinet, and then sliding the receiver out of the cabinet. The 8-3/4" x 19" front panel of the receiver has holes suitably spaced to fit the standard 19-inch radio relay rack.

2-3. ANTENNAS

The r-f input of the receiver is designed for operation from either a single-wire antenna, or a half-wave doublet or other tuned antenna with transmission line impedances from 52 to 600 ohms. Antenna connections are made to a three terminal strip at the rear of the receiver marked "A1", "A2", and "G". Mounting holes are also provided, adjacent to the antenna terminals, for installation of an AN type SO-239 connector for coaxial cable installations.

A. SINGLE WIRE ANTENNA

The simplest antenna and one which will provide satisfactory results throughout the entire tuning range is a conventional single-wire antenna, 50 to 100 feet long. This type of antenna should be erected as high as possible and kept free from surrounding objects. When using a single-wire antenna, attach the antenna lead-in to terminal "A1" and connect the jumper link between terminals "A2" and "G". In some locations, reception may be improved by connecting a ground wire between terminal "G" and a cold water pipe or outside ground rod.

B. HALF-WAVE DOUBLET

For top performance, especially on the shortwave ranges, the use of a half-wave doublet or other type of antenna employing a 52 to 600-ohm transmission line is recommended. The doublet antenna should be cut to the proper length for the most used frequency or band of frequencies. The overall length in feet of a half-wave doublet is determined by the following formula:

$$\text{Length in feet} = \frac{468}{\text{Frequency in megacycles}}$$

The doublet antenna may be fed with either a balanced or unbalanced transmission line. When a balanced transmission line such as "twin-lead" or a twisted pair is used, the two leads are connected to terminals "A1" and "A2", and the jumper link between terminals "A2" and "G" is disconnected. When using an unbalanced transmission line such as coaxial cable, the inner conductor connects to terminal "A1", the outer braid connects to "A2", and the jumper link connects between "A2" and "G".

The doublet antenna provides optimum efficiency only at the frequency for which it is cut. Therefore, it may be desirable for reception on frequencies remote from the antenna frequency to utilize the antenna as a single wire type. This is accomplished by connecting the two transmission line leads together and connecting them to terminal "A1". The jumper link in this case should be connected between terminals "A2" and "G".

In an installation where the receiver is used in conjunction with a transmitter, it may be advantageous to use the same antenna for receiving as for transmitting. This is especially true when a directive antenna is used since the directive effects and power gain of the transmitting antenna are the same for receiving as for transmitting. Switching of the antenna from the transmitter to the receiver may be accomplished with a double-pole, double-throw antenna changeover relay or knife switch connected in the antenna leads.

For further information regarding antennas, refer to the "Radio Amateur's Handbook" or the "A.R.R.L. Antenna Book", both published by the American Radio Relay League; West Hartford, Conn., U.S.A.

CAUTION: When using the SX-88 receiver in close proximity to transmitting equipment, avoid excessive r-f voltage at the antenna terminals of the receiver during transmission. Nearby antennas or even short lengths of transmission line between the receiver and antenna relay can pick up high r-f potentials. Voltages in excess of 50 volts at the receiver antenna terminals can destroy the protective neon lamp and antenna stage coils.

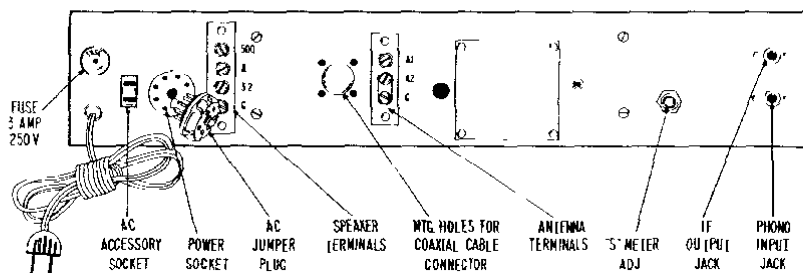

Fig. 1. Rear View of Receiver

920,2744

2-4. POWER SOURCE

The SX-88 receiver is designed for operation on 105-125 volt, 50-60 cycle AC current while the universal model, the SX-88U, operates on 100-250 volt, 25-60 cycle AC current. The normal power consumption of each receiver is 138 watts. Each receiver is also equipped with a DC power input socket to permit operation on an external power supply or batteries for portable or emergency service in areas where AC power is not available. This socket is located at the rear of the receiver and is marked "POWER SOCKET". In addition to equipping the receiver for DC operation, the POWER SOCKET also supplies 300 volts DC at 10 ma between pins 1 and 3, and 6.3 volts AC at .6 amp between pins 1 and 6 for operating accessories.

A. AC OPERATION

Insert the line cord plug into any convenient AC power outlet of the proper rating. If in doubt about your power source, call your local power company before plugging in the receiver.

CAUTION: When operating the SX-88U, it is essential that the power selector switch (located on the rear of the power transformer) be set for the voltage at the AC outlet before plugging in the receiver. Failure to observe this precaution may result in serious damage.

NOTE: The receiver will not operate from an AC source unless the AC JUMPER PLUG is inserted in the POWER SOCKET at the rear of the receiver. (See Fig. 1.)

B. DC OPERATION

The receiver may be operated from an external DC source, such as a vibrator power supply or batteries, by removing the AC JUMPER PLUG normally located in the POWER SOCKET at the rear of the receiver, and replacing it with a similar octal plug wired as shown in Fig. 2. Note that pins 7 and 8 of the DC plug are connected together by a jumper wire so that the 4H4 current regulator tube is automatically disconnected to supply the correct heater voltage to the 6U8 tube when operating from an external 6-volt source. The voltage and current requirements for DC operation are as follows: "B" supply, 300 volts at 200 ma; "A" supply, 6 volts at 6 amps.

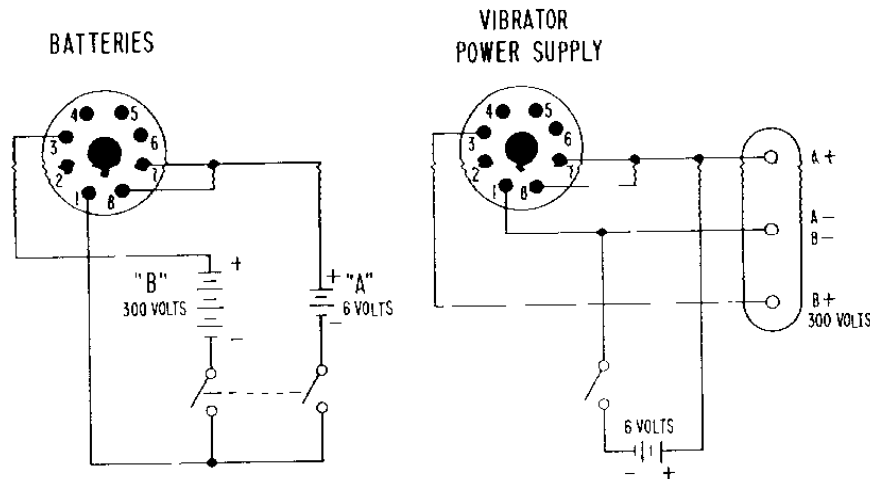

Fig. 2. Wiring Diagram for DC Operation

92B22-1

2-5. SPEAKER CONNECTION

A four-terminal strip, marked "G-3.2-8-500", is provided at the rear of the receiver for the speaker connections. Approximately 10 watts of audio power are available at these terminals. Any speaker having an impedance of either 3.2 or 8 ohms can be used with the receiver by simply connecting one lead from the speaker to the common ground terminal marked "G" and the other lead to the numbered terminal which corresponds to the speaker voice coil impedance. For optimum results, the use of the Hallicrafters R-46 or R-46A speaker is recommended. The R-46 speaker has a built-in matching transformer and connects to terminals "G" and "500" while the R-46A, which has no matching transformer, connects to the terminals marked "G" and "3.2". When using a speaker with an impedance other than 3.2 or 8 ohms, a matching transformer should be used to insure optimum performance. The matching transformer should have a 10-watt power rating, a 500-ohm primary impedance, and a secondary impedance to match the impedance of the speaker being used.

2-6. HEADPHONES

The headphone jack, marked PHONES, is located on the front panel of the receiver and is wired so that the speaker is automatically disabled when the headphones are plugged in. The headphone output load impedance is not critical and any commercial type headphones may be used, including crystal types as no direct current flows in the headphone circuit. For maximum headphone output, the use of high-impedance magnetic or crystal phones is recommended.

2-7. RECORD PLAYER CONNECTIONS

An audio input jack, marked PHONO, is provided at the rear of the receiver for attachment of a record player using either a crystal pickup, or a magnetic pickup with a suitable pre-amplifier. Connection to the PHONO jack is made with a standard single-pin phono plug. Shielded type cable should be used to prevent hum, connecting the inner conductor to the center prong of the plug, and the outer metal braid to the shell of the plug.

For phono operation, set the BAND WIDTH control on the front panel at "PHONO" and operate the VOLUME and RESPONSE controls as explained under Sections 3-7 and 3-12. The remaining controls are inoperative and will have no effect on phono operation.

2-8. RELAY AND TRANSMITTER SWITCHING

One half of the dpdt REC-STANDBY switch on the front panel connects to pins 2 and 5 of the POWER SOCKET at the rear of the receiver, and is available for transmitter switching. (See Fig. 3) This half of the switch is wired so that it is closed when the REC-STANDBY switch is set at "STANDBY" and open when set at "REC". To reverse the switching sequence (i.e., to have the switch open when the REC-STANDBY switch is set at "STANDBY" and closed when set at "REC") disconnect the lead on the switch which connects to pin 5 of the POWER SOCKET and connect it to the unused terminal on the switch.

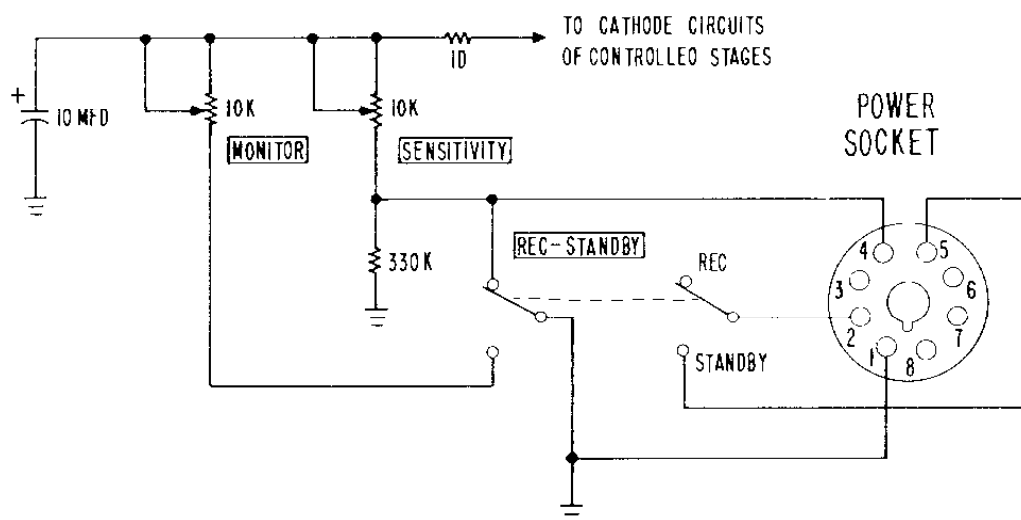

Fig. 3. Schematic Diagram of Sensitivity and Monitor Control Circuits, and Rec-Standby Circuit.

-247757

2-9. REMOTE REC-STANDBY SWITCH

The receiver may be disabled remotely by connecting a remote spst switch between pins 1 and 4 of the AC JUMPER PLUG located in the POWER SOCKET at the rear of the receiver. (See Fig. 3). To operate the receiver from a remote location, set the REC-STANDBY switch on the front panel at "STANDBY" and use the remote switch to place the receiver in "receive" or "standby" operation.

2-10. AC ACCESSORY OUTLET

An AC outlet is provided at the rear of the receiver for operating a record player, oscilloscope, or accessories.

2-11. IF OUTPUT JACK

The IF OUTPUT jack at the rear of the receiver provides a low impedance cathode follower output at the second intermediate frequency of 50 kc for feeding a teletype converter, oscilloscope, etc. The i-f output signal is obtained from the grid of the 3rd 50 kc IF amplifier, amplified by the AVC amplifier, coupled to the cathode follower, and then fed through a DC blocking capacitor to the IF OUTPUT jack. The IF OUTPUT jack will be operative only if the AVC switch is set at "ON".

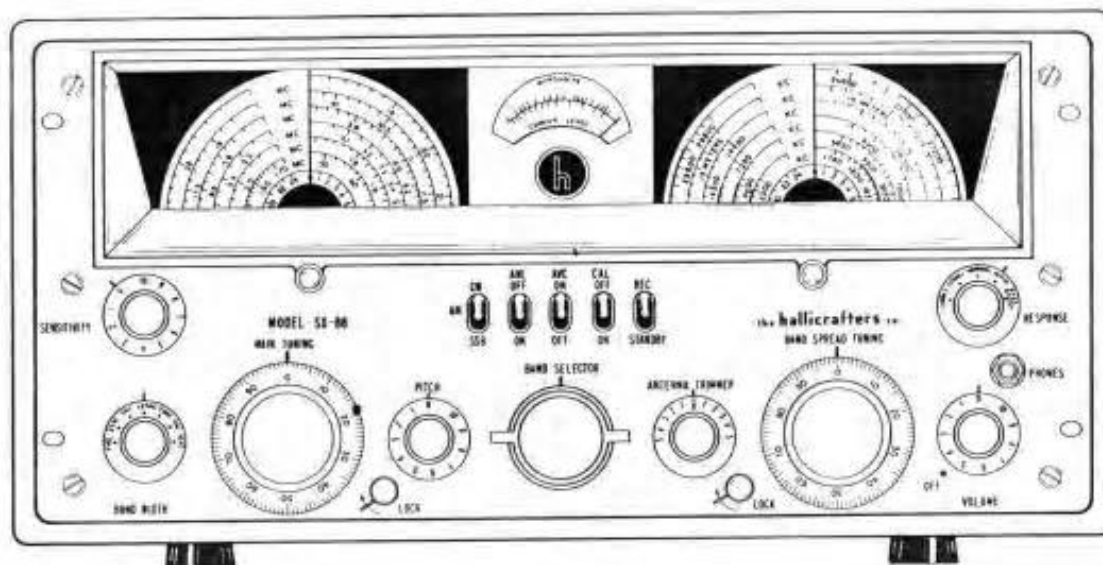

Fig. 4. Operating Controls

9102754

SECTION 3. FUNCTION OF OPERATING CONTROLS

3-1. SENSITIVITY CONTROL

The SENSITIVITY control varies the gain of the 1st and 2nd RF amplifier stages and the 1st, 2nd, and 3rd 50 kc IF amplifier stages. Maximum sensitivity is obtained with the control set at "10" (fully clockwise). In this position, the tubes being controlled are operated at maximum gain with minimum cathode bias. As the control is rotated counterclockwise, the bias on the tubes increases with a resultant decrease in gain.

3-2. CW-AM-SSB SWITCH

This switch, when set at "CW" or "SSB", applies plate voltage to the beat frequency oscillator (BFO) to render it operative for the reception of CW or single-sideband signals. The beat frequency oscillator employs a Hartley oscillator circuit and its voltage regulated to insure highly stable operation. Oscillator lock-in is eliminated since the output of the beat oscillator is coupled to the second-detector through a tuned buffer amplifier. When the CW-AM-SSB switch is set at "SSB", the cathode bias resistor of the BFO buffer amplifier tube is decreased in value, thus providing increased BFO output for proper reception of single-sideband signals. The "AM" position of the CW-AM-SSB switch disables the BFO for normal reception of standard broadcast and AM phone signals.

3-3. ANL SWITCH

This switch, when set at "ON", places the automatic series noise limiter circuit in operation to reduce pulse type noise such as ignition noise and electrical interference. The limiter circuit allows the signal to pass through the receiver unaffected, but makes the receiver inoperative for noise amplitudes greater than those of the signal. It will work equally well on AM or CW signals and is self-adjusting, i.e., it automatically adjusts itself to the signal level.

The noise limiter circuit "chops" noise peaks received at the detector by means of a biased diode which becomes nonconducting above a predetermined signal level. The audio output of the detector must pass through the limiter diode to the grid of the audio amplifier when the limiter circuit is in operation. The limiter diode normally acts as a conductor for the audio signal as long as the diode plate is positive

with respect its cathode. When a noise peak is higher in amplitude than the signal, it instantaneously swings the plate negative with respect to the cathode, conduction ceases, and that portion of the signal is automatically cut off from the audio amplifier. The point at which the limiter diode becomes non-conducting is made sufficiently high so that the diode will not clip modulation peaks and thus impair intelligibility appreciably, but low enough to limit the noise peaks effectively.

3-4. AVC SWITCH

The AVC switch, when set at "ON", places the AVC circuit in operation to maintain the output level of the receiver constant regardless of normal input-signal variations. AVC voltage is applied to the 1st and 2nd RF amplifier stages, 2nd mixer, and 1st 50 kc IF stage. Since delayed AVC is employed in the receiver, the AVC circuit does not come into operation (i.e., it is delayed) until the carrier strength reaches a pre-determined level. The result is that no AVC voltage is applied to the grids of the controlled stages until the required carrier strength is reached. With this arrangement, the AVC bias on the controlled tubes is zero until the peak voltage applied to the plate of the AVC diode exceeds the delay voltage applied to its cathode. Thus, the AVC circuit offers very effective control on average and strong signals and yet maintains full receiver sensitivity on weak signals.

In the conventional AVC circuit, which uses the rectified carrier voltage developed at the detector, the use of AVC for CW reception results in a loss of sensitivity when the BFO is switched on. This occurs because the beat oscillator output acts exactly as a strong received signal, and causes the AVC circuit to put high bias on the controlled stages, thus reducing the receiver sensitivity. In the SX-88 receiver, this undesirable effect is eliminated by completely isolating the AVC circuit from the second detector by means of an AVC amplifier stage which obtains its input signal ahead of the detector stage, (and BFO), thus permitting the reception of CW signals with AVC functioning.

3-5. CAL. OFF-ON SWITCH

The CAL. OFF-ON switch controls the operation of the built-in crystal calibrator. When the switch is set at "ON", the crystal calibrator is turned on to provide marker signals at every 100 kc on the dial for checking the dial calibration accuracy. The crystal calibrator employs a crystal controlled, pentode oscillator circuit. The output of the crystal calibrator is capacitively coupled to the antenna input circuit. A trimmer capacitor, adjustable by the CRYSTAL ADJ control on the top front of the chassis, permits adjustment of the calibrating crystal to exactly 100 kc by comparison with the frequencies transmitted by WWV. This capacitor has been set at the factory and should normally not require periodic readjustment unless extreme calibration accuracy is required. If adjustment is required, proceed as outlined in Section 7-7.

3-6. REC-STANDBY SWITCH

The REC-STANDBY switch, normally set at "REC", permits disabling of the receiver during transmission periods, at the same time maintaining the heater and plate supplies operative for instant use when reception is again resumed. The receiver is disabled by setting the REC-STANDBY switch at "STANDBY".

NOTE: When the REC-STANDBY switch is set at "STANDBY", the receiver may still be made operative, if desired, by means of the MONITOR control on the top rear of the chassis. This permits monitoring of your own transmitter signal when the REC-STANDBY switch is being used to control the transmitter. Only when the MONITOR control is rotated fully counterclockwise (zero sensitivity position) will the receiver be completely disabled when the REC-STANDBY switch is set at "STANDBY".

One section of the REC-STANDBY switch may be used for relay or transmitter switching, if desired. For connections and details, refer to Section 2-8.

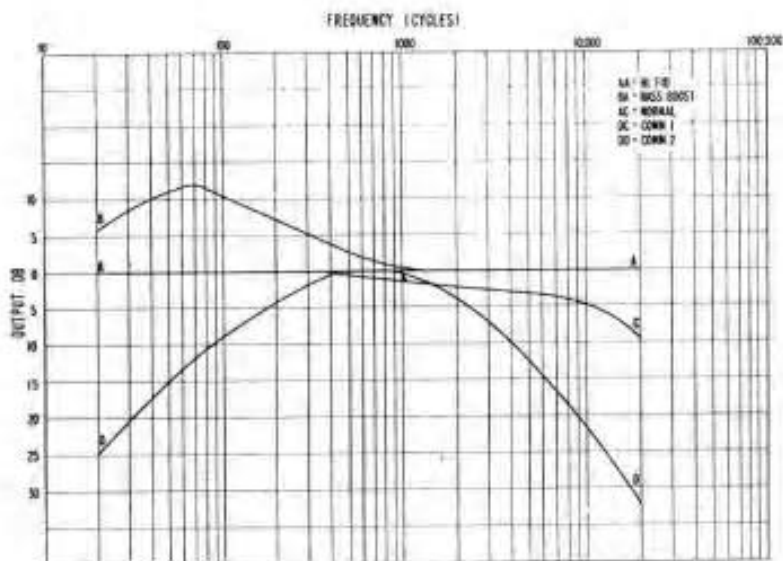

Fig. 5. Audio Response Curves

9701755

3-7. RESPONSE CONTROL

The RESPONSE control varies the frequency characteristics of the receiver audio system. The five types of response available are BASS BOOST, HI FID, NORMAL, COMM 1, and COMM 2. For broadcast reception and phono operation, the BASS BOOST and HI FID positions are recommended while for the reception of CW and AM phone signals, where intelligibility rather than fidelity is the primary concern, the NORMAL, COMM 1, and COMM 2 positions are usually more desirable. Fig. 5 shows the frequency characteristics obtained with the control set in each of its five positions.

A. HI FID (High Fidelity)

This position provides an essentially flat response from 20 to 20,000 cycles, thereby providing as near true reproduction of the original signal as possible. This position is recommended for high fidelity reproduction of AM broadcast programs, tapes, and records.

B. BASS BOOST

In this position, the response at the high frequency end of the audio range remains the same as in the "HI FID" position; however, the level of the low audio frequencies is boosted approximately 10 db above that of the mid and high audio frequencies.

C. NORMAL

In this position, the response is essentially flat at the low and mid-frequencies and slightly attenuated at the high frequencies. The "NORMAL" position may be used to improve the signal-to-noise ratio when excessive background noise or static is experienced.

D. COMM 1 & COMM 2

These positions are especially useful for communication work under sharp selectivity conditions (BAND WIDTH control set at ".25 KC" or ".5 KC"). The "COMM 1" and "COMM 2" provide attenuation at both the high and low frequency ends of the audio range. The response in the two positions differs only in the amount of attenuation at the high frequency end, the "COMM 2" position providing considerably greater attenuation than the "COMM 1" position.

3-8. BAND WIDTH CONTROL

The BAND WIDTH control is used to vary the selectivity of the receiver to fit receiving conditions. Six degrees of Selectivity are available, ranging from 250 cycles, for CW reception under crowded band conditions, to 10 kilocycles for maximum fidelity for broadcast reception. The six selectivity positions are shown on the BAND WIDTH control and indicate receiver selectivity at 6 db down. A seventh position on the control, marked "PHONO", disables all of the receiver circuits except the audio system for phonograph operation.

For broadcast reception, the BAND WIDTH control is normally set at "5 KC" or "10 KC", the positions affording broad selectivity. Selectivity may be progressively increased by turning the BAND WIDTH control to the positions marked "2.5 KC", "1.25 KC", ".5 KC", and ".25 KC". For reception of the crowded amateur and shortwave bands, it is generally advisable to sacrifice fidelity for greater selectivity, since the added selectivity reduces both adjacent-channel interference and background noise by attenuating the higher audio frequencies. Too much selectivity on AM signals, however, will attenuate the high audio frequencies to such an extent that the signal may become unintelligible as a result of excessive side-band cutting. When receiving CW signals, the sharpest selectivity position may be used without the loss of intelligibility experienced in AM reception.

3-9. PITCH CONTROL

The PITCH control operates the tuning slug in the BFO coil to vary the frequency of the beat frequency oscillator approximately 2.5 kc each side of its center frequency of 50 kc. The primary function of the PITCH control is to vary the pitch of the audible beat note when receiving CW signals. It is also used when receiving single-side band signals to vary the frequency of the reinserted carrier in the receiver.

3-10. BAND SELECTOR CONTROL

The BAND SELECTOR control operates the band switch to select the desired band of frequencies. The frequency range or band covered by each position of the BAND SELECTOR control is indicated directly on the control. The band in use on the main tuning and band spread tuning dials is illuminated for ease in tuning.

The BAND SELECTOR control performs three functions on each band: (1) it places the proper set of coils and sections of the main and band spread tuning capacitors into the circuit to cover the desired frequency range. (2) it selects the bias resistor in the cathode circuit of the 2nd RF amplifier stage to provide the proper gain for each band, and (3) it switches the 2nd conversion oscillators and 1st mixer plate to operate at the required first intermediate frequency (2075 kc on bands 1, 3, 4, 5, and 6; 1550 kc on band 2).

3-11. ANTENNA TRIMMER CONTROL

The ANTENNA TRIMMER control operates a variable capacitor connected across the secondary of the antenna coil of the band in use. This capacitor adjustment compensates for loading effects of various types of antenna installations.

3-12. VOLUME CONTROL

The VOLUME control adjusts the audio level at the speaker terminals and phones jack and, in addition, turns the receiver on and off. Clockwise rotation of the control turns the receiver on and increases the signal applied to the grid of the audio amplifier tube, thus increasing the receiver volume.

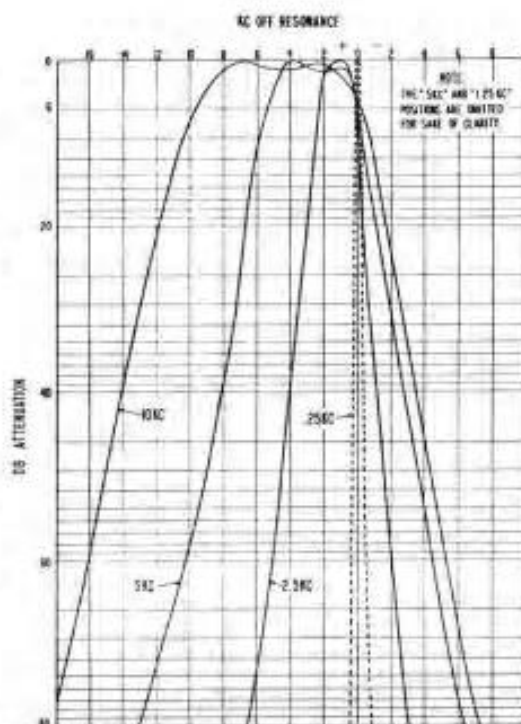

Fig. 6. IF Selectivity Curves

3-13. MAIN TUNING DIAL

The main tuning dial has six calibrated scales and a 24-division logging scale. Each division on the logging scale represents one complete revolution of the MAIN TUNING control. Since the metal skirt of the MAIN TUNING control is calibrated from 0 to 100, this method of tuning divides each scale on the main tuning dial into 2400 readable settings. Thus, by recording the settings of the logging scale and MAIN TUNING control, the receiver may be accurately reset to any desired frequency. A tuning lock to the right of the MAIN TUNING control permits positive locking action without affecting the frequency setting of the main tuning dial. To lock the main tuning dial, simply turn the locking knob clockwise.

IMPORTANT: The calibration on the main tuning dial will be accurate only if the band spread tuning gang is set at minimum capacity. This is accomplished by rotating the BAND SPREAD TUNING control counterclockwise until the dial pointer is aligned with the index marks at the high frequency end of the dial. If the band spread tuning gang is set at any setting other than minimum capacity, the additional band spread capacity, added to the main tuning capacity, would throw off the main tuning dial calibration because the receiver is calibrated with the band spread tuning gang set at minimum capacity.

The dial settings for the amateur bands are indicated on the main tuning dial by white dots and wavelength in meters (160, 80, 40, etc.). When tuning the amateur bands with the band spread dial, the main tuning dial must be set and locked at the setting corresponding to the desired amateur band.

3-14. BAND SPREAD TUNING DIAL

The band spread tuning dial contains a 24-division logging scale and six scales calibrated for the 160, 80, 40, 20, 15, and 11-10 meter amateur bands. The six scales are calibrated to read receiver frequency directly when the main tuning dial has been set to the index dot of the desired amateur band. If precise calibration accuracy is desired on the amateur bands, the main tuning dial should be more accurately set the means of the built-in 100 kc crystal calibrator as outlined in Section 4-4A, "Calibration of the Band Spread Dial".

Each division of the 24-division logging scale on the band spread dial represents one complete revolution of the BAND SPREAD TUNING control. Since the metal skirt of the BAND SPREAD TUNING control is calibrated from 0 to 100, this method of tuning divides each scale on the band spread dial into 2400 readable settings. Thus, by recording the settings of the logging scale and the BAND SPREAD TUNING control, the receiver may be accurately reset to any desired frequency. A tuning lock to the left of the BAND SPREAD TUNING control permits positive locking action without affecting the setting of the band spread tuning dial. To lock the band spread tuning dial, simply turn the locking knob clockwise.

In addition to its use on the amateur bands, the band spread tuning dial may also be utilized as a fine tuning adjustment over any portion of the frequency range on bands 2, 3, 4, 5, and 6. Fine tuning is accomplished as follows:

- (a) Set the band spread tuning gang at minimum capacity by rotating the BAND SPREAD TUNING control counterclockwise until the dial pointer is aligned with the index marks at the high frequency end of the dial.
- (b) Set the main tuning dial at the high frequency end of the range of frequencies to be covered and then slowly tune through the range using the BAND SPREAD TUNING control.

3-15. MONITOR CONTROL

The MONITOR control on the top rear of the chassis permits adjustment of the receiver sensitivity when monitoring your own transmitter signal. The MONITOR control is an auxiliary sensitivity control switched in the circuit only when the REC-STANDBY switch is set at "STANDBY", it replaces the SENSITIVITY control on the front panel which is switched out of the circuit during standby operation. When monitoring your transmitter signal, the receiver antenna should be disconnected by relay or switching device so the signal will not "block" or damage the receiver. As a further precaution against overloading, the MONITOR control should not be advanced any further than necessary to hear the transmitter signal. When it is not desired to monitor the transmitter signal, the MONITOR control should be set fully counterclockwise (zero sensitivity position) so that the receiver will be completely disabled when the REC-STANDBY switch is set at "STANDBY".

SECTION 4. OPERATION

4-1. AM RECEPTION

1. Set the front panel controls to their starting positions as outlined below.

VOLUME OFF
BAND SELECTOR At the desired band. (Band in use will be illuminated when receiver is turned on.)
SENSITIVITY 10 (maximum sensitivity)
BAND WIDTH 5 KC (2.5 KC or 10 KC if desired)
CW-AM-SSB AM
ANL OFF-ON OFF
AVC ON-OFF ON
CAL OFF-ON OFF
REC-STANDBY REC
ANTENNA TRIMMER . . . 0 (zero)
RESPONSE NORMAL (or as desired)

2. Loosen the tuning locks at the sides of the MAIN TUNING and BAND SPREAD TUNING controls by turning the LOCK knobs counterclockwise.

IMPORTANT

Before making any tuning adjustments with the MAIN TUNING or BAND SPREAD TUNING controls, it is essential that the dial pointers be properly indexed by means of the small knob located directly below each dial. This is accomplished by rotating the MAIN TUNING and BAND SPREAD TUNING controls fully clockwise and aligning the dial pointers with the index marks at the low frequency end of the dial.

3. Turn the receiver on by rotating the VOLUME control clockwise. The band in use on the main tuning and band spread tuning dials will light up indicating the receiver is operative. Adjust the VOLUME control for the desired volume level.
4. Set the band spread tuning gang at minimum capacity by rotating the BAND SPREAD TUNING control counterclockwise until the dial pointer is aligned with the index marks at the high frequency end of the dial. The band spread tuning dial may now be locked in position, if desired, to avoid disturbing its setting. The band spread tuning dial is calibrated for the 160, 80, 40, 20, 15, and 11-10 meter amateur bands. For convenience in tuning, the AM phone bands are indicated on the band spread dial by a wide line directly above their location on the dial. For fine tuning of the amateur and shortwave bands with the BAND SPREAD TUNING control, see Section 3-14. The BAND SPREAD TUNING control has no effect on standard broadcast reception (Band 1).

IMPORTANT

The frequency calibration of the main tuning dial will be correct only if the band spread tuning gang is set at minimum capacity as specified above.

5. Tune in the desired signal with the MAIN TUNING control, tuning for maximum indication on the "S" meter. The dial calibrations on all bands are located above the frequency markings. After the signal has been accurately tuned in, adjust the ANTENNA TRIMMER control for maximum indication on the "S" meter, and then set the VOLUME control for the desired volume level.

NOTE

The "S" meter indications will be correct only when the AVC switch is set at "ON", and the SENSITIVITY control is set at 10 (maximum sensitivity setting). If the SENSITIVITY control is set at a setting other than "10", AVC action will also be somewhat restricted.

6. Set the **BAND WIDTH** control for the desired degree of selectivity. For standard broadcast reception (Band 1), the control is normally set at "10 KC" for maximum fidelity. The positions marked "5 KC", "2.5 KC", "1.25 KC", ".5 KC", and ".25 KC" provide progressively increasing steps of selectivity. Note that as the selectivity of the receiver is increased, the background noise and interference from adjacent signals is reduced. Too much selectivity, however, will cause excessive side-band cutting. While side-band cutting reduces fidelity, it may be frequently preferable to sacrifice naturalness of reproduction in favor of communications effectiveness. When changing the position of the **BAND WIDTH** control from a broad to a narrower response (for example: from "2.5 KC" to "1.25 KC"), a slight readjustment of the tuning controls may be necessary to recenter the signal in the i-f pass-band.
7. Set the **RESPONSE** control for the desired tonal quality.
8. If it is desired to operate with **AVC** off, set the **AVC** switch at "OFF", set the **VOLUME** control to a well advanced position, and vary the receiver volume level by means of the **SENSITIVITY** control to avoid "blocking" by strong signals.
9. If severe electrical disturbances or ignition or other types of pulse-type noise interfere with reception, set the **ANL** switch at "ON" to place the automatic noise limiter circuit in operation.
10. The receiver may be disabled without turning it off by setting the **REC-STANDBY** switch at "STANDBY". In this position, the r-f and i-f stages are cut off but the heater and plate supplies remain operative for instant reception. To resume reception, simply return the switch to the "REC" position.

4-2. CW RECEPTION

For CW reception, set the **VOLUME** control at a well advanced position and vary the volume level of the receiver by means of the **SENSITIVITY** control, taking care not to advance the control to a point where strong signals will cause excessive "thumping" (overloading). The receiver may be operated with **AVC** on or off, as desired. (See Section 3-4.) Operation of the receiver with **AVC** on is highly desirable since it not only minimizes fading but also prevents blasting when tuning from a weak to a strong signal.

CW signals are made audible by the heterodyning action of the beat oscillator with the incoming signal. The beat oscillator is set at a frequency slightly different from the second-intermediate frequency of 50 kc, the difference being equal to the pitch of the audible note desired. To adjust the beat oscillator frequency, first tune in a steady, unmodulated carrier with the beat oscillator turned off (CW-AM-SSB switch set at "AM"), the **AVC** switch set at "ON", and the **BAND WIDTH** control set at ".25 KC" (the sharpest selectivity position). If desired, the built-in crystal calibrator may be used as the signal source as it provides a suitable carrier at every multiple of 100 kc on the dial. The crystal calibrator is made operative by setting the **CAL OFF-ON** switch at "ON". Adjust the receiver tuning to the carrier frequency as indicated by a maximum indication on the "S" meter. (This centers the carrier in the i-f passband.) Then turn on the beat oscillator by setting CW-AM-SSB switch at "CW" and adjust its frequency by means of the **PITCH** control (leaving the receiver tuning unchanged) to give a pleasing beat note. The beat oscillator may be set on either the high- or low-frequency side of zero beat. (The beat oscillator operates on the high side when the **PITCH** control is set at a position to the right of "0", and on the low side when the **PITCH** control is set at a position to the left of "0".) After the **PITCH** control is set, turn off the crystal calibrator by setting the **CAL OFF-ON** switch at "OFF", tune in a CW signal, and adjust the **ANTENNA TRIMMER** control for maximum loudness. With the receiver in the sharpest selectivity position, CW signals will drop in and out rapidly as the receiver is tuned across a band, and a slow rate of tuning is highly desirable. Once the **PITCH** control has been set, it need not be reset for each CW signal.

NOTE

If a CW signal is tuned in with the **BAND WIDTH** control at a setting other than ".25 KC", it may be necessary to slightly readjust the receiver tuning when changing to a narrower response in order to properly position the signal in the i-f pass-band.

The setting of the **BAND WIDTH** control for CW reception is generally best determined by receiving conditions. Note that as the selectivity of the receiver is increased (**BAND WIDTH** control varied in steps from the "10 KC" to the ".25 KC" position), the background noise and adjacent-channel interference is considerably reduced. For CW reception, the sharpest selectivity position may be used without loss of intelligibility experienced in AM reception.

The RESPONSE control and automatic noise limiter (ANL) circuit can be used to great advantage on CW reception, just as on AM reception, to reduce the effects of background noise and electrical interference. For CW reception, the "COMM 1" and "COMM 2" positions of the RESPONSE control can prove very effective in improving the signal-to-noise ratio by attenuating both the lower and higher audio frequencies. Maximum attenuation of these frequencies is obtained with the RESPONSE control set at "COMM 2".

4-3. SINGLE SIDEBAND RECEPTION

Single-sideband signals are transmitted with little or no carrier, and it is necessary to reinsert the carrier in the receiver before proper reception is obtained. In the SX-88 receiver, this is accomplished in the 50 kc i-f system by injecting the beat oscillator signal at the input of the second-detector. A single-sideband signal can be identified by its unintelligibility, and by a severe variation in the "S" meter indication corresponding to the speech modulation.

For single-sideband reception, set the AVC switch at "ON", the CW-AM-SSB switch at "SSB", RESPONSE control at "COMM 1" or "COMM 2", and the BAND WIDTH control at either "1.25 KC" or "2.5 KC", depending upon adjacent-channel interference and noise. Set the SENSITIVITY control at a well advanced position and vary the receiver volume level by means of the VOLUME control. Initially set the PITCH control at either "0", or the position marked "4" to the right of "0". The single-sideband signal will be intelligible at only one of these two settings, the proper setting depending upon the sideband being transmitted. If the signal is not intelligible after tuning is completed as outlined below, set the PITCH control to the other setting and repeat the tuning procedure.

Tune in the single-sideband signal for maximum loudness with as good intelligibility as possible. (This centers the signal in the i-f passband.) After the signal is properly tuned in, adjust the ANTENNA TRIMMER control for maximum loudness and then very carefully adjust the PITCH control for best intelligibility. If the PITCH control is improperly set, the speech will sound high- or low-pitched, or very distorted. Best intelligibility will be obtained with the PITCH control set very close to its initial setting, usually not more than 1/2 division on either side of the initial setting.

The "1.25 KC" position of the BAND WIDTH control permits reception of modulating frequencies up to about 1500 cycles. For reception of modulating frequencies higher than 1500 cycles, set the BAND WIDTH control to the positions marked "2.5 KC", "5 KC", or "10 KC", depending on the degree of fidelity desired; maximum fidelity is obtained in the "10 KC" position.

4-4. USE OF CRYSTAL CALIBRATOR

The built-in 100 kc crystal calibrator permits accurate dial calibration over any portion of the main and band spread tuning dials by a comparison of the dial calibrations with the marker signals which appear at every multiple of 100 kc on the dial. Any calibration adjustment required can be made by adjustment of the dial pointer from the front of the receiver.

IMPORTANT

Before making any calibration adjustment, it is essential that the main tuning and band spread tuning dial pointers be properly indexed. This is accomplished by rotating the MAIN TUNING and BAND SPREAD TUNING controls fully clockwise and aligning the dial pointers with the index marks at the low frequency end of the dial by means of the small knob located directly below each dial.

A. CALIBRATION OF THE BAND SPREAD DIAL

1. Set the band spread tuning dial at a convenient multiple of 100 kc at the high frequency end of the band in use. For example: 2000 kc on 160M, 4000 kc on 80M, 7300 kc on 40M, 14,400 kc on 20M, 21,500 kc on 15M and 29,800 on 10M. (The band spread tuning dial is calibrated in kc.)
2. Set the main tuning dial to the index dot of the desired amateur band.
3. Set the CW-AM-SSB switch at "CW", the PITCH control at "0", and the CAL OFF-ON switch at "ON".

4. Very carefully adjust the MAIN TUNING control for exact frequency as indicated by "zero beat" and then lock the main tuning dial in place to avoid disturbing its setting. The band spread tuning dial is now accurately calibrated and a "zero beat" should be obtained at every multiple of 100 kc on the band in use. For example, on the 80 meter amateur band, a "zero beat" should be obtained at 3500, 3600, 3700, 3800, 3900, and 4000 kc.
5. The procedure outlined in Steps 1 through 4 above provides average calibration accuracy over the entire frequency range of the band in use. For precise calibration accuracy over a particular section of the band, the procedure is identical except that the band spread dial is set at a multiple of 100 kc near the desired frequency or range of frequencies, instead of at the high end of the band as in Step 1.

B. CALIBRATION OF THE MAIN TUNING DIAL

1. Turn the BAND SPREAD TUNING control counterclockwise until the dial pointer is aligned with the index marks at the high frequency end of the dial. Then lock the band spread dial in place to avoid disturbing its setting.
2. Set the main tuning dial at a convenient multiple of 100 kc near the desired frequency or range of frequencies. (The main tuning dial is calibrated in mc.) To determine the nearest 100 kc multiple, simply remember that 100 kc is equal to one-tenth mc. For example, from 2.0 to 3.0 mc on band 2, the 100 kc multiples are 2.0 mc, 2.1 mc, 2.2 mc, 2.3 mc, etc.
3. Set the CW-AM-SSB switch at "CW", and the PITCH control to "0". Then set the CAL OFF-ON switch at "ON" and very carefully adjust the MAIN TUNING control for a "zero beat". After "zero beat" is obtained, very carefully index the main tuning dial pointer (by means of the small knob directly below the dial) with the nearest 100 kc multiple on the dial.

4-5. USE OF "S" METER

The "S" meter provides a visual means of determining whether or not the receiver is properly tuned, as well as an indication of the relative signal strength. The "S" meter circuit consists of a DC milliammeter connected in series with the plate lead to the 1st RF amplifier tube, the grid of which is controlled by AVC voltage. Since the plate current of this tube varies with the strength of the incoming signal, the meter will indicate relative signal strength. The "S" meter is calibrated in microvolts, "S" units from 1 to 9, and in decibels above S-9 to +40 db. The indications on the "S" meter will be correct only when the SENSITIVITY control is set at "10" (maximum sensitivity), and the AVC switch is set at "ON".

The limitations of the microvolt scale should be fully appreciated before any assumption as to the indicated signal voltages is accepted. The meter has been calibrated in microvolts of signal strength as developed at the antenna input terminals when terminated in a 52-ohm load, on bands 2 and 3. The microvolt scale will be somewhat less accurate under other load conditions and on bands 1, 4, 5, and 6.

4-6. SERVICE OR OPERATING QUESTIONS

For further information concerning operation or servicing of your receiver, contact your Hallicrafters dealer. The Hallicrafters Co. maintains an extensive system of Authorized Service Centers where any required service can be performed promptly and efficiently at a nominal charge. For the location of the one nearest you, consult your local dealer or telephone directory. Make no service shipments to the factory as the Hallicrafters Co. will not accept the responsibility for unauthorized shipments.

The Hallicrafters Co. reserves the privilege of making revisions in current production of equipment and assumes no obligation to incorporate these revisions in earlier models.

SECTION 5. ALIGNMENT

This receiver has been carefully aligned at the factory by specially trained personnel using precision equipment. Alignment of the receiver should not be attempted until all other possible causes of faulty operation have been investigated. Alignment should not be required unless the receiver has been tampered with or unless component parts have been replaced in the r-f or i-f stages. Alignment should be made only by persons familiar with communications receivers and experienced in their alignment. Refer to Figs. 10 and 11 for the location of all alignment adjustments.

5-1. EQUIPMENT REQUIRED

1. Vacuum tube voltmeter (VTVM) or other high impedance DC voltmeter.
2. Signal generator covering 50 KC to 30 MC.
3. Non-metallic alignment tool for IF alignment with dimensions shown in Fig. 7.
4. Alignment tools for RF alignment.
5. Output meter (or AC scale of VTVM or other suitable meter). Connect the output meter to the appropriate speaker terminals. The receiver output should be properly terminated with a dummy load if a VTVM is used.

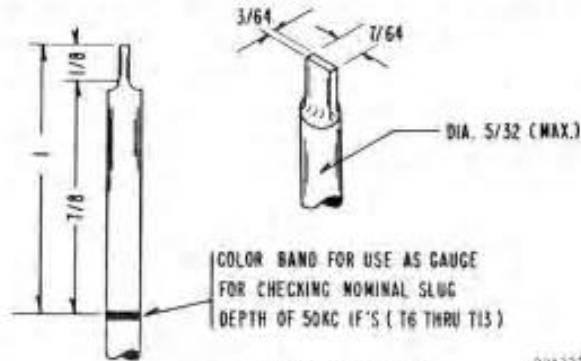

Fig. 7. IF Alignment Tool

9242211

5-2. INITIAL CONTROL SETTINGS

Band Selector	As indicated in chart.
Sensitivity and Volume	10 (maximum)
Band Width	As indicated in chart.
CW-AM-SSB	AM
ANL, AVC, and Cal.	Off
Rec-Standby	Rec
Response	Normal
Main Tuning and Band Spread	
Tuning Dials	At high frequency end

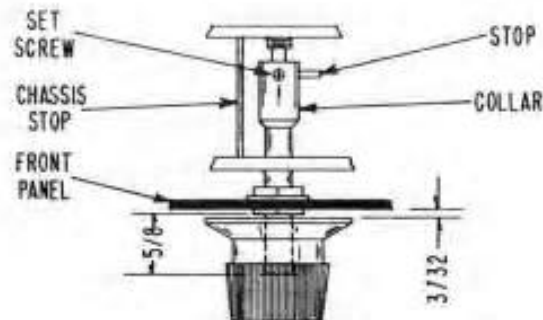

Fig. 8. Pitch Control

9242215

5-3. ALIGNMENT PROCEDURE

Step	Dummy Antenna	Signal Generator Connections	Signal Generator Frequency	Band Selector Setting	Output Connections	Band Width Setting	Remarks
50 KC IF ALIGNMENT							
1	Direct	Disconnect wire lead from terminal 4 of T3 (Fig. 11). Connect high side of generator to lead and low side to chassis.	50 KC (unmod)	1	VTVM DC probe to test point "A" (detector load resistor). See Fig. 11. Common to chassis.	.25 KC	Adjust T6, T7, T8, T9, T10, T11, T12, and T13 (50 KC IFs) for maximum indication, maintaining approx. 1 volt reading on VTVM. It is possible to obtain resonance at two different positions of the tuning slug. In the correct position, the top of the slug is approx. 7/8" from top of coil retaining clip. See Fig. 7.
BFO ADJUSTMENT							
2	"	"	"	"	" (Use 100-volt or higher range for Step 2.)	"	Set CW-AM-SSB switch at "CW". Using speaker as indicator, adjust Pitch control for "zero beat". If knob reads zero and has equal rotation either side of zero, no further adjustment is required. If not, remove knob and loosen set screw and stop on collar. (See Fig. 8.) Adjust L31 (BFO coil) for "zero beat" thru hollow collar. Then position collar so that stop on collar is diametrically opposite chassis stop and so that Pitch control shaft protrudes approx. 5/8" from panel bushing as shown in Fig. 8. Tighten set screw and stop and position knob on shaft so that knob reads zero and so that rear of knob is approx. 3/32" from front panel. When properly positioned, tighten knob set screws. Next set CW-AM-SSB switch at "SSB" and adjust L32 (BFO amp coil) for maximum indication on VTVM. Switching from "SSB" to "CW" should produce approx. an 8 to 1 voltage change (decreasing). After completing Step 2, return CW-AM-SSB switch to "AM".

Step	Dummy Antenna	Signal Generator Connections	Signal Generator Frequency	Band Selector Setting	Output Connections	Band Width Setting	Remarks
AVC AMP. ADJUSTMENT							
3	"	"	"	"	VTVM DC probe to test point "B" (AVC bus). See Fig. 11. Common to chassis.	10 KC	Tune generator slowly thru 50 KC to determine IF passband. Then set generator frequency to center of passband. Next set AVC switch at "ON" and increase generator output to overcome delay bias on AVC amp tube. Adjust L28 (AVC amp coil) for maximum AVC voltage as indicated on VTVM. Maintain approx. 1 volt reading on VTVM. After completing Step 3, reconnect lead to terminal 4 on T3 and return AVC switch to "OFF".
2075 KC IF ALIGNMENT							
4	"	Remove gang housing cover and connect high side of generator to test point "C" (stator of section C1F of main tuning gang). See Fig. 10. Low side to frame of gang.	2075 KC (mod)	"	Output meter across appropriate speaker terminals. (VTVM to test point "A" if it desired to monitor detector voltage.)	"	Tune generator slowly thru 2075 KC to determine IF passband. Then set generator to center of passband, using sufficient generator output to obtain approx. 1/2 watt receiver output. If no output is obtained, the 2125 KC crystal oscillator may not be oscillating and it will be necessary to turn up the generator output and adjust the 2125 KC crystal activity adjustment (bottom slug of T5) until output is obtained. Adjust for maximum output by adjusting the signal generator frequency, crystal activity (bottom slug of T5) and the 2075 KC IFs (top and bottom slugs of T1 and T3). Note that the signal suddenly disappears when the crystal activity slug is turned into the coil and gradually drops in level when the slug is backed out of the coil. Set the crystal activity adjustment (bottom slug of T5) for half output on the gentle slope side of maximum response. Then set the generator as near the center of the IF passband as possible and adjust the top and bottom slugs of T1 and T3 for maximum output. Tune through the passband and observe the shape of the response. If it is symmetrical the adjustment is completed; if not, reset the generator frequency near the center of the passband and repeat T1 and T3.
1550 KC IF ALIGNMENT							
5	"	"	1550 KC (mod)	2	"	"	Adjust the signal generator frequency, the 1500 KC crystal activity adjustment (top slug of T5), and the 1550 KC IFs (top and bottom slugs of T2 and T4) using the same general procedure outlined in Step 4 for the 2075 KC IF.
IF SENSITIVITY CHECK							
6	With the generator connected as in Step 4 and modulated 30% at 400 cycles, the IF input required for 1/2 watt receiver output should be 100 microvolts or less at 2075 KC (Band 1) and 50 microvolts or less at 1550 KC (Band 2). This assumes the crystal activity is set for half of maximum response as outlined in Steps 4 and 5 above.						
RF ALIGNMENT							
Before proceeding with the RF alignment:				Set the SENSITIVITY and VOLUME at "10" (maximum), BAND WIDTH at "5 KC", AVC, ANL, and CAL at "OFF", CW-AM-SSB at "AM", REC-STANDBY at "REC", and RESPONSE AT "NORMAL".			
<p>A. Rotate the MAIN TUNING and BAND SPREAD TUNING controls fully clockwise and align the dial pointers with the index marks at the low frequency end of the dial by means of the small knob directly below each dial.</p> <p>B. Then rotate the BAND SPREAD TUNING control counterclockwise until the dial pointer is aligned with the index marks at the high frequency end of the dial. Lock the band spread dial in position to avoid disturbing its setting.</p>				The oscillator frequency is higher than the signal frequency on all bands.			
RF alignment must be made with the bottom shield cover in place.							
Use a modulated signal.							
Connect the output meter across the appropriate speaker terminals. (Connect the VTVM to test point "A" if it is desired to monitor the detector voltage.) Maintain a 1/2 watt receiver output.							

Fig. 9. RTMA Dummy Antenna

52A1549

RF ALIGNMENT (Cont.)					
Step	Dummy Antenna	Signal Generator Connections	Generator & Receiver Frequency	Band Selector Setting	Adjust for Maximum
7	RTMA Dummy (Fig. 9)	High side to antenna terminal A1. Low side to A2. Jumper between A2 and G.	1.50 MC	1	C114 (osc. trimmer), C29 (mixer trimmer), and ANTENNA TRIMMER control on front panel.
			.56 MC	"	L24 (osc. slug) and L18 (mixer slug)
8	47-ohm carbon resistor	"	2.8 MC	2	C111 (osc. trimmer), C28 (mixer trimmer), C16 (RF trimmer), and ANTENNA TRIMMER control.
			1.8 MC	"	L23 (osc. slug), L17 (mixer slug), L11 (RF slug), and L5 (antenna slug)
9	"	"	1.55 MC	"	Set main tuning gang fully closed. Set generator frequency for maximum IF response, using sufficient generator output to obtain 1/2 watt receiver output. Then adjust L6 (1550 KC trap) for maximum rejection (minimum output indication).
10	"	"	5.1 MC	3	C107 (osc. trimmer), C27 (mixer trimmer), C15 (RF trimmer), and ANTENNA TRIMMER control.
			3.2 MC	"	L22 (osc. slug), L16 (mixer slug), and L10 (RF slug)
11	"	"	9.0 MC	4	C102 (osc. trimmer), C26 (mixer trimmer), C14 (RF trimmer), and ANTENNA TRIMMER control.
			5.8 MC	"	L21 (osc. slug), L15 (mixer slug), and L9 (RF slug)
12	"	"	16.5 MC	5	C99 (osc. trimmer), C25 (mixer trimmer), C12 (RF trimmer), and ANTENNA TRIMMER control.
			10.3 MC	"	L20 (osc. slug), L14 (mixer slug), and L8 (RF slug)
13	"	"	30.0 MC	6	C93 (osc. trimmer), C23 (mixer trimmer), C11 (RF trimmer), and ANTENNA TRIMMER control.
			18.7 MC	"	L19 (osc. slug), L13 (mixer slug), and L7 (RF slug)
SENSITIVITY ADJUSTMENT					
14	<p>Set the AVC switch at "ON", BAND SELECTOR at Band 3, and the main tuning dial to 3.2 MC. Short the antenna terminals and adjust the "S" METER ADJ control at the rear of the receiver until the meter pointer is in line with the left-hand index marks on the meter. (NOTE: With the receiver turned off, the "S" meter pointer should be in line with the right-hand index marks on the meter. If not, remove the "b" insignia directly below the meter and turn the adjustment screw as required.) Set the signal generator to 3.2 MC, adjust the generator for 50 microvolt output, and then adjust the bottom slug of T5 for 50 microvolts on the "S" meter. CAUTION: The bottom slug of T5 should be set so that the crystal oscillator is operating on the gentle slope portion of its tuning characteristic.</p> <p>Switch the BAND SELECTOR to Band 2, set the generator and main tuning dial at 1.8 MC, adjust the generator for a 50 microvolt output, and then adjust the top slug of T5 for 50 microvolts on the "S" meter, again operating on the gentle slope portion of the oscillator tuning characteristic.</p>				

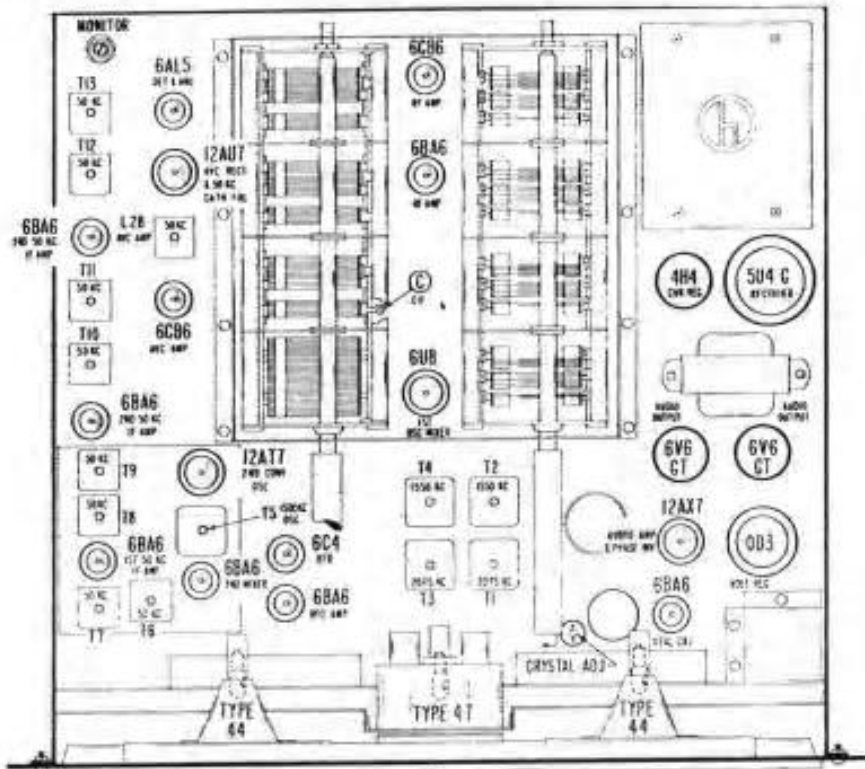

Fig. 10. Top View of Chassis Showing Location of Alignment Adjustments, Tubes, and Dial Lamps

9202245

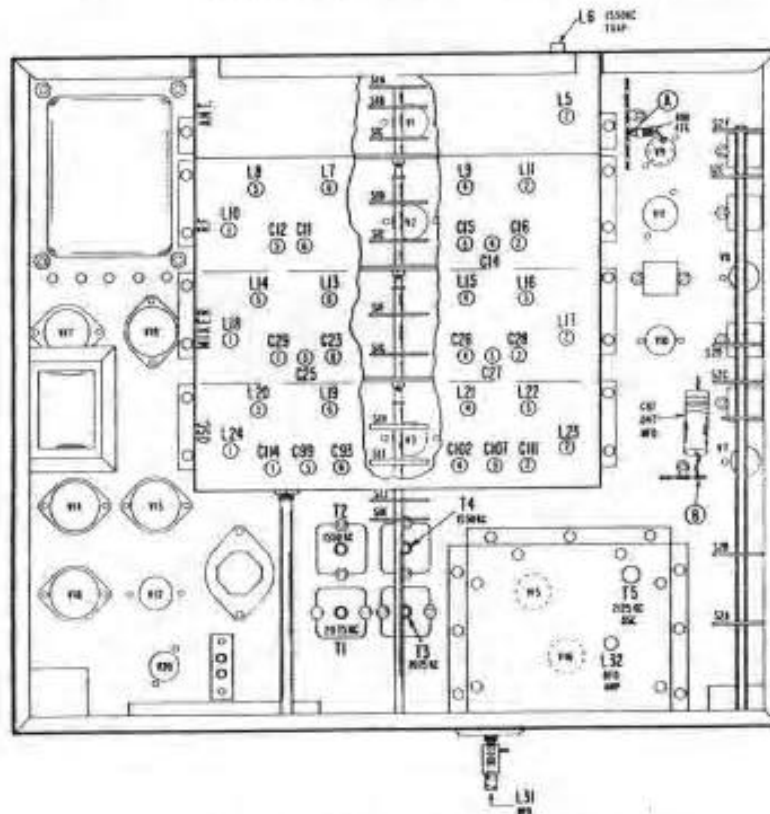

Fig. 11. Bottom View of Chassis Showing Location of Alignment Adjustments and Tubes

SECTION 6. PERFORMANCE DATA FOR SERVICE ENGINEERS

MEASUREMENT CONDITIONS

1. POWER SOURCE: 117 volts, 60 cycles AC
2. STANDARD AUDIO
OUTPUT: .5 watt into 500 ohms
3. MODULATION: 30% at 400 cycles
4. DUMMY ANTENNA:
Band 1: RTMA Dummy
Bands 2-6: 47 ohms
5. Oscillator frequency higher than signal frequency on all bands.
6. CONTROL SETTINGS:
Sensitivity - 10 (max)
Volume - 10 (max)
ANL, AVC, and CAL - Off
CW-AM-SSB - AM
Band Width - 5 KC
Band Selector - Band 1
Response - Normal
Main Tuning Dial - gang half open
Band Spread Dial - index marks at high end

** IF REJECTION

BAND	MIN DB	BAND	MIN DB
1	50	4	80
2	80	5	80
3	80	6	80

** Band Spread gang fully open

* IF BANDWIDTH (2075 KC)

BAND WIDTH CONTROL SETTING	6 DB (X2)	60 DB (X1000)
.25 KC	.15 - .25 KC	1.0 KC (Max)
.5 KC	.38 - .57 KC	1.8 KC "
1.25 KC	1.0 - 1.5 KC	3.8 KC "
2.5 KC	2.0 - 3.0 KC	7.9 KC "
5 KC	4.0 - 6.0 KC	15.0 KC "
10 KC	8.0 - 12.0 KC	24.0 KC "

* IF performance thru 1550 KC channel (Band 2) is essentially the same as 2075 KC channel.

AUDIO PERFORMANCE

POWER OUTPUT: 10 watts (max)
 FREQUENCY RESPONSE: ± 2 db from 20 to 20,000 cycles thru Phono input with Response at Hi Fid (500 ohm output)
 HARMONIC DISTORTION: Less than 10% at 10 watt output with 400 cycles at Phono input.
 HUM: Less than 15 uw with Volume at min. and Response at Hi Fid.
 BASS BOOST: Not less than 8 db at 70 cycles.

BAND	FREQ. (MC)	RF SENSITIVITY		IMAGE RATIO (MIN DB)
		MAX. UV FOR .5 WATT OUTPUT	MAX. UV FOR 10 DB SIG/NOISE	
1	.56	8.0	12.0	100
	1.0	6.0	12.0	80
	1.5	5.0	12.0	80
2	1.8	1.0	2.0	100
	2.3	1.0	1.5	100
	2.8	1.0	1.5	90
3	3.2	1.0	1.5	100
	4.1	1.0	1.5	90
	5.1	1.0	1.5	80
4	5.6	1.0	1.5	90
	7.3	1.0	1.5	80
	9.0	1.0	1.5	80
5	10.3	1.0	1.5	90
	13.4	1.0	1.5	80
	16.5	1.0	1.5	70
6	18.7	1.5	2.0	70
	24.0	1.5	2.0	60
	30.0	1.5	2.0	58

SECTION 7. SERVICE DATA

7-1. TECHNICAL SPECIFICATIONS

TUBES: 20 tubes including current regulator, voltage regulator, and rectifier.

SPEAKER OUTPUT: 3.2, 8, and 500 ohms

HEADPHONE OUTPUT: High impedance

ANTENNA INPUT: For single wire or 52-600 ohm balanced or unbalanced line.

PHONO INPUT: High impedance

***POWER SOURCE:**

Model SX-88 . . . 105-125 volts, 50-60 cycles

Model SX-88U . . . 100-250 volts, 25-60 cycles.

POWER CONSUMPTION: 138 watts

RECEPTION: AM, CW, and SSB

AUDIO OUTPUT: 10 watts (maximum)

INTERMEDIATE FREQUENCIES (Double Conversion):

Band 1, 3-6 50 KC & 2075 KC

Band 2 50 KC & 1550 KC

FREQUENCY COVERAGE

Band	Frequency Range	Calibrated Band Spread
1	.535 - 1.7 MC	-
2	1.69 - 3.0 MC	160M
3	2.98 - 5.5 MC	80M
4	5.4 - 10.0 MC	40M
5	9.8 - 18.3 MC	20M
6	17.8 - 33.0 MC	15M, 11-10M

* Provisions are also included for operation from an external DC power source.

7-2. CHASSIS REMOVAL

To remove the chassis from the cabinet, remove two screws at each side of the front panel and four screws at the bottom of the cabinet.

7-3. TUBE and DIAL LAMP REPLACEMENT

To gain access to the tubes and dial lamps, raise the hinged top cover of the cabinet. The tube locations, as well as their functions, are shown in Fig. 10.

7-4. 50 KC IF SYSTEM

Fig. 12 shows the type of coupling used in the 50 kc IF stages. Note that inductive coupling is avoided by careful shielding of the IF coils and signal transfer occurs only through capacitance and resistance. By increasing the value of "C" and "R", the selectivity is made more broad while by decreasing their values, the selectivity is made more sharp. The proper values of "C" and "R" are switched in the circuit by means of the BAND WIDTH control. "R" varies the "Q" of the circuit and "C" varies the coupling. This R-C coupling arrangement affords a more accurate means of selectivity control than that readily obtainable by any other method.

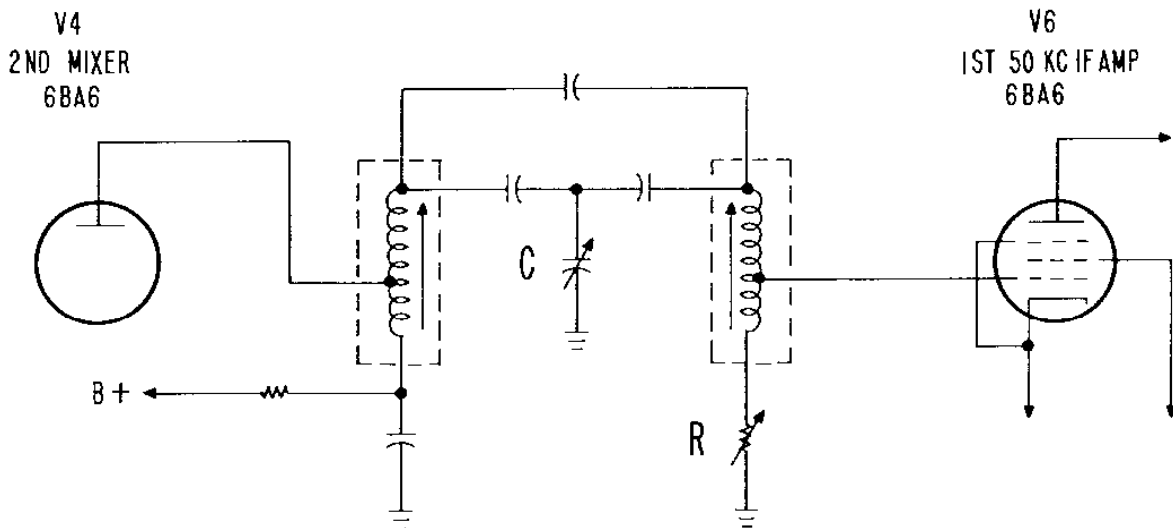

Fig. 12. Portion of 50 KC IF System

9282763

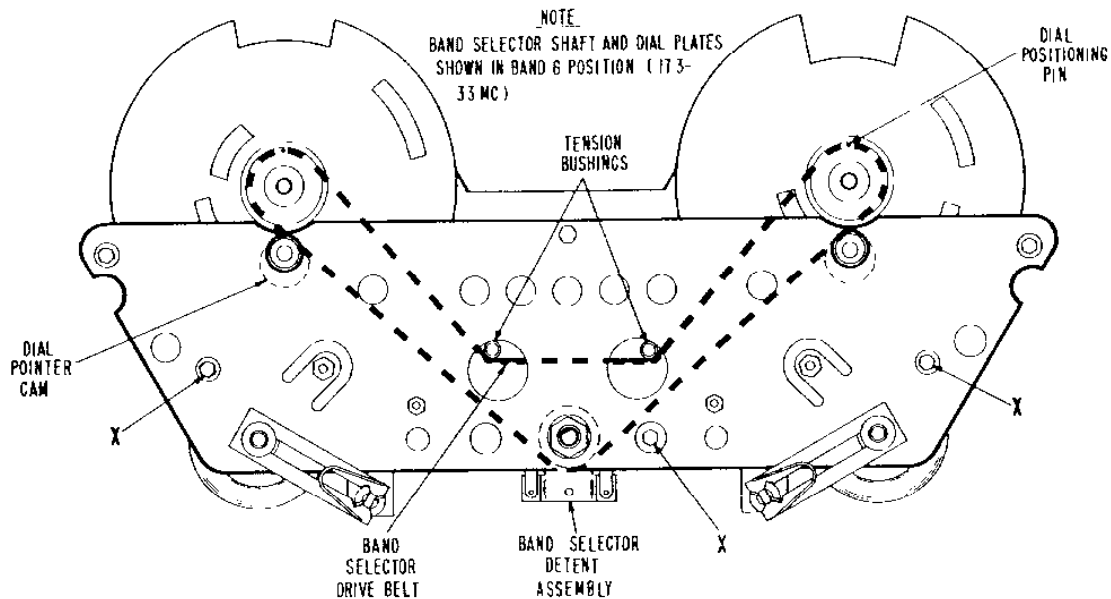

Fig. 13. Front View of Gear Drive Mechanism

99C2777

7-5. BAND SELECTOR DRIVE BELT REPLACEMENT (Refer to Fig. 13)

1. Set Band Selector control to Band 6 (17.8 - 33 mc).
2. Remove chassis from cabinet by removing four screws at bottom of cabinet and two screws at each side of front panel.
3. Remove all front control knobs and PHONES jack mounting nut.
4. Remove front panel from chassis by removing three screws at each side of front panel.
5. Remove dial lamp brackets by removing two self-tapping hex head screws at rear and binding head screw and nut at side.
6. Remove "S" meter by removing two Phillips head screws directly below meter (at the front).
7. Remove toggle switch mounting nuts and then remove switches from gear mechanism.
8. Loosen flexible coupling on Band Selector shaft and slide toward rear on shaft.
9. Loosen couplings on main tuning and band spread gangs and slide toward rear on shaft.
10. Remove gear mechanism from chassis by removing three self-tapping hex head screws marked "X" in Fig. 13.
11. Remove dial pointers by removing retaining clip at front of pointer.
12. Remove large hex nut from front of both dials and then remove dials.

CAUTION: To prevent scratching the dials, position the dial pointer cams downward as shown in Fig. 13 and bend the dials sufficiently when removing to provide clearance between the dial and dial pointer cams.
13. Loosen hex nut on one of the two drive belt tension bushings at rear of mechanism and then slip drive belt up over bushings.
14. Remove Band Selector detent assembly from gear mechanism by removing hex nut at front.
15. Remove drive belt by slipping up over dial plate and rotating dial plate as required to provide clearance for removal.
16. To replace drive belt, reverse sequence used above for removing belt. When replacing belt, position both dial plates so that cutout at outer edge of dial plate is vertical as shown in Fig. 13. This is correct position of dial plates when the Band Selector is set at Band 6.
17. Before tightening the main tuning and band spread couplings in place, fully mesh the main tuning and band spread gangs and rotate the MAIN TUNING and BAND SPREAD TUNING controls fully clockwise.

7-6. "S" METER ADJUSTMENTS

The "S" meter has two adjustments, one mechanical and the other electrical. The mechanical adjustment, accessible by removal of the "h" insignia directly below the meter, has been accurately set at the factory and will normally not require any further adjustment. Adjustment can be made, if required, by turning off the receiver and carefully rotating the adjustment screw until the meter pointer is in line with the right-hand index mark.

The electrical adjustment of the "S" meter is made by carefully turning the "S" METER ADJ control at the rear of the receiver, until the meter pointer is in line with the left-hand index mark. The electrical adjustment should be made with the receiver on, antenna terminals shorted, SENSITIVITY at "10", CW-AM-SSB switch at "AM", AVC switch at "ON", CAL OFF-ON switch at "OFF", REC-STANDBY switch at "REC", and BAND SELECTOR at Band 3. The settings of the remaining controls do not affect the "S" meter reading.

7-7. ADJUSTMENT OF CRYSTAL ADJ CONTROL

The CRYSTAL ADJ control on the top front of the chassis operates a trimmer capacitor connected across the 100 kc calibrating crystal. This trimmer capacitor permits adjustment of the calibrating crystal to exactly 100 kc by comparison with the frequencies transmitted by station WWV. This capacitor has been set at the factory and should normally not require periodic readjustment unless extreme calibration accuracy is desired. If adjustment is required, proceed as outlined below.

Set the CW-AM-SSB switch at "AM", the CAL OFF-ON switch at "OFF", and all other front panel controls as for normal AM reception. Tune in station WWV on any one of its operating frequencies (2.5, 5, 10, 15, 20, or 25 mc) and wait for the period during which the signal from WWV is unmodulated. Then switch on the crystal calibrator by setting the CAL OFF-ON switch at "ON" and adjust its frequency, by means of the CRYSTAL ADJ control, until the crystal calibrator signal "zero beats" with the signal received from WWV. If adjustment is attempted during periods that WWV is modulated, zero beat may be obtained with the modulating frequency rather than the desired carrier frequency.

7-8. CONTROL KNOB POSITIONING

SENSITIVITY "0" at full counterclockwise rotation
BAND WIDTH "10 KC" at full counterclockwise rotation
MAIN TUNING "0" at full clockwise rotation
BAND SELECTOR As required by flat on shaft
ANTENNA TRIMMER "5" to right of "0" with antenna trimmer variable capacitor fully meshed
BAND SPREAD TUNING "0" at full clockwise rotation
RESPONSE "BASS BOOST" at full counterclockwise rotation
VOLUME Align "0" with index line at full counterclockwise rotation
LOCK As shown in Fig. 4 at full clockwise rotation
PITCH Tune in a steady, unmodulated carrier with the CW-AM-SSB switch at "AM", AVC switch at "ON", and the BAND WIDTH control at ".25 KC". (If desired, the built-in crystal calibrator may be used as the carrier source.) Then set the CW-AM-SSB switch at "CW", adjust the PITCH control for "zero beat", and set the knob at "0" with approx 3/32" clearance between the front panel and rear of knob.

7-9. SERVICING OF GEAR DRIVE TUNING MECHANISM

The gear drive tuning mechanism in your receiver is precision built to Hallicrafters most exacting standards. If not tampered with, this mechanism will provide long, trouble free performance. No attempt should be made to service this mechanism in the field other than to replace the band selector drive belt (Section 7.5). If service is required, consult the Hallicrafters dealer, distributor, or Authorized Service Center in your locality. Make no service shipments to the factory as the Hallicrafters Company will not accept the responsibility for unauthorized shipments. Removal of the mechanism from the receiver can be accomplished by following Steps 1 through 10 of Section 7.5. After reassembling the mechanism in the receiver, synchronize the tuning mechanism with the gangs as outlined in Step 17 of Section 7.5.

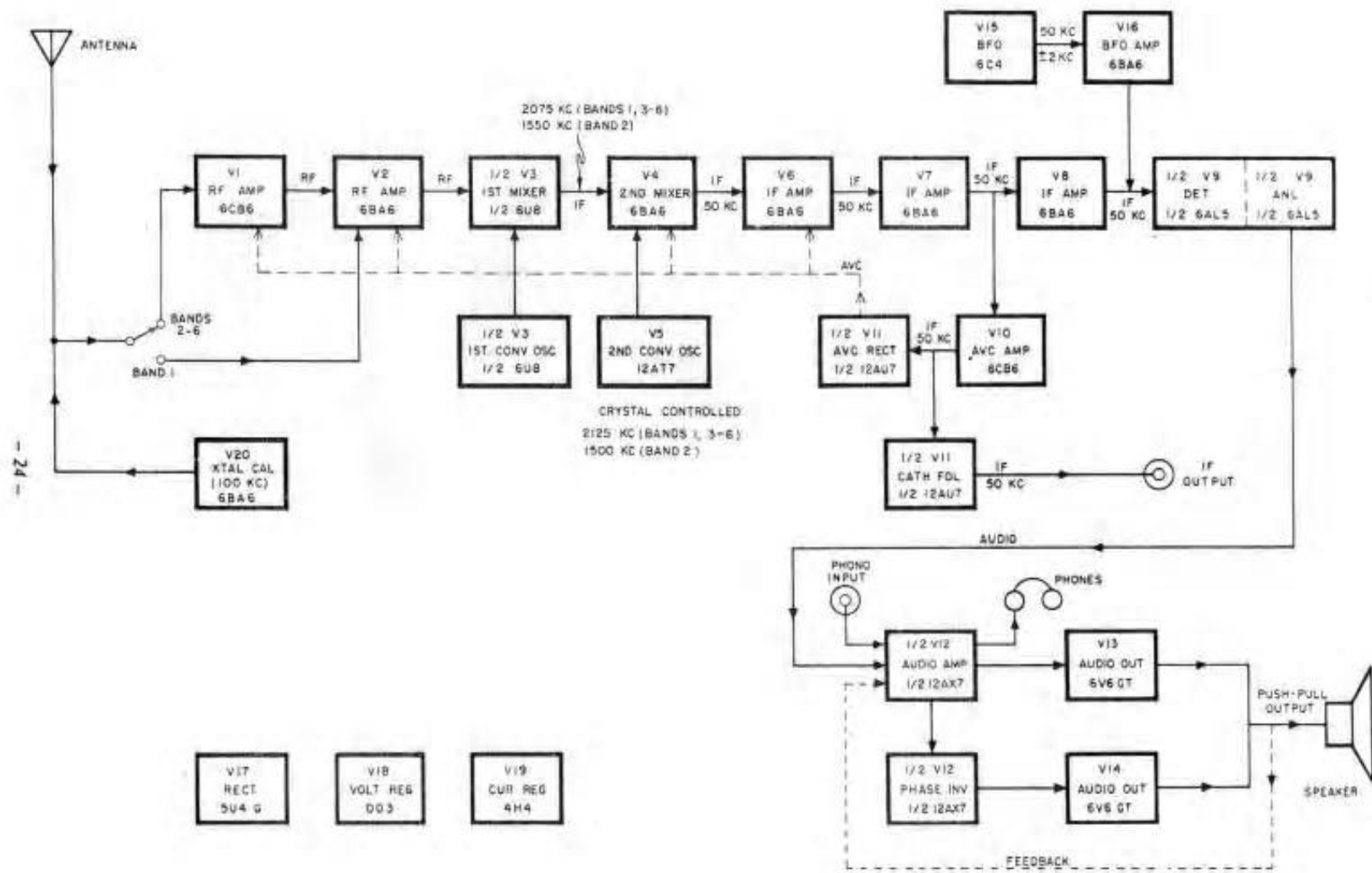

Fig. 14. Block Diagram of Receiver

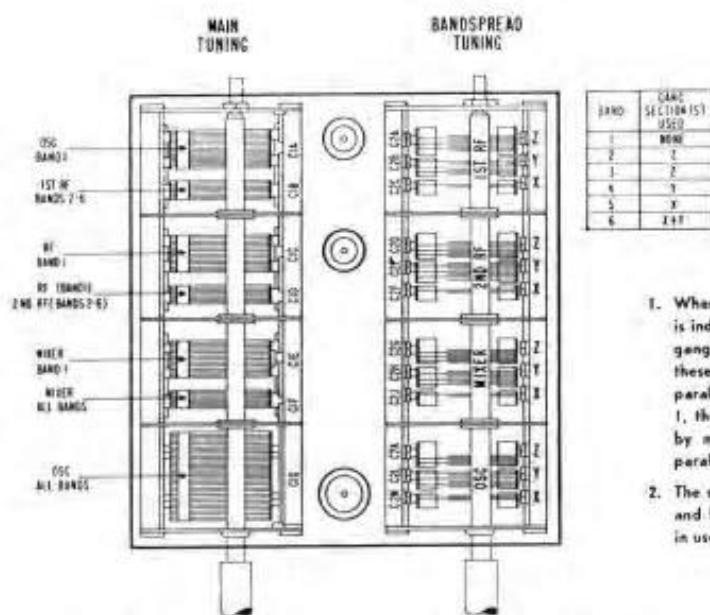

Fig. 15. Location and Function of Tuning Gang Sections

92C2213

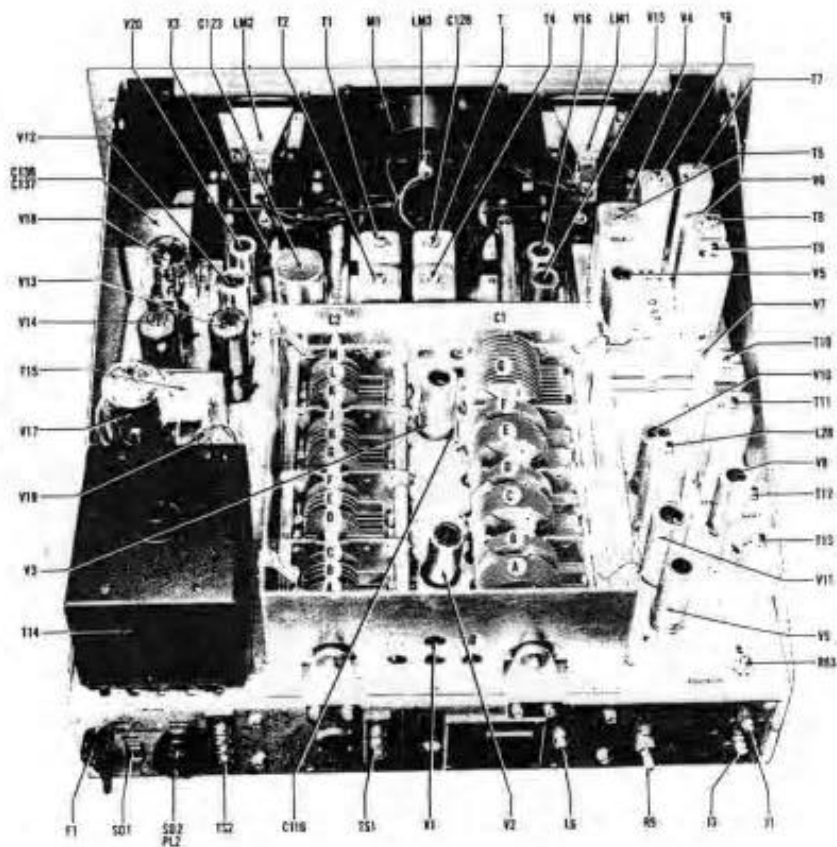

Fig. 16. Top View of Chassis Showing Component Location

92C2246

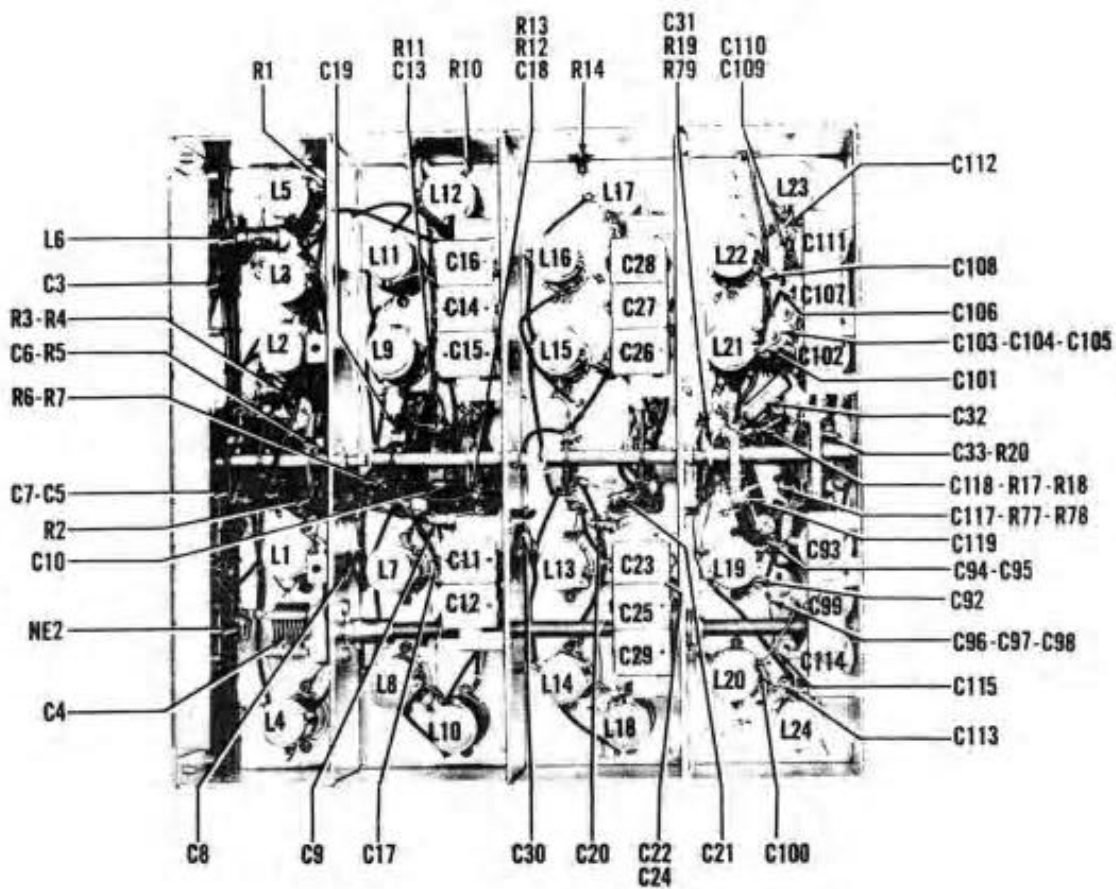

Fig. 17. Bottom View of RF Deck Showing Component Location

92X224E

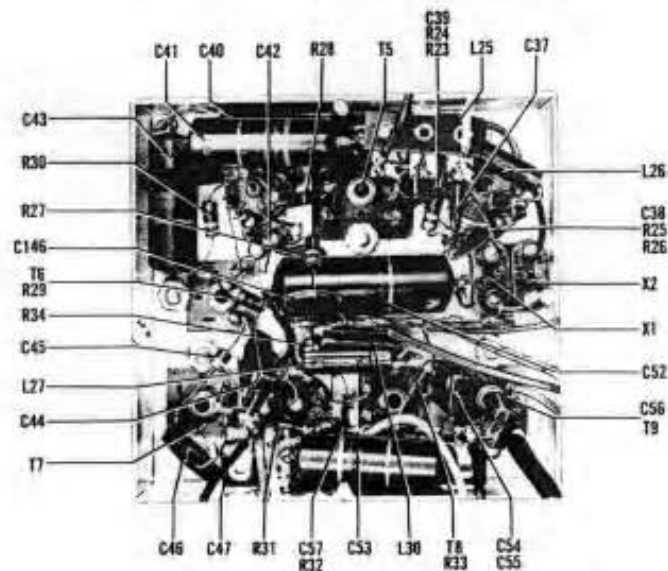
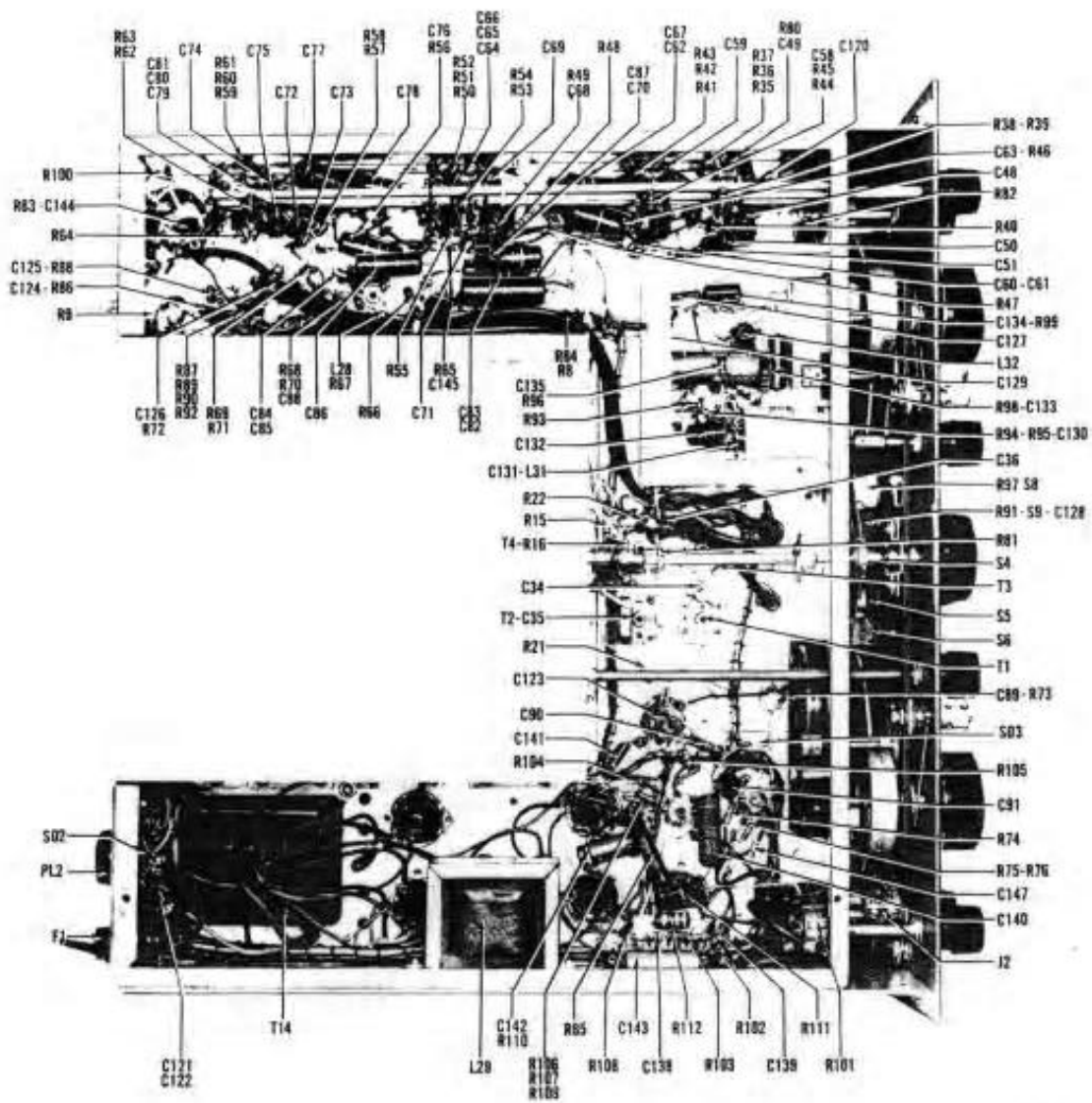

Fig. 18. Bottom View of 2nd Converter Sub-Chassis Showing Component Location

92X224F



9237247

Fig. 19. Bottom View of Chassis Component Location

SERVICE PARTS LISTS

Schematic Symbol	Description	Hallicrafters Part Number	Schematic Symbol	Description	Hallicrafters Part Number
CAPACITORS			CAPACITORS (Cont)		
C-1	Tuning gang, 7 section (Main Tuning)	48D314	C-94	1000 mmfd. 5%, N2200 ± 500 PPM, ceramic	47B441
C-2	Tuning gang, 12 section (Bandspread Tuning)	48D315	C-95	2200 mmfd. 5%, 500 V., silver mica	47X30E222J
C-3	1000 mmfd. 5%, 500 V., silver mica	47X20D102J	C-96,97,98	443 mmfd. 2%, N330, 500 V., ceramic	47B407
C-4	4-50 mmfd., variable air (Antenna Trimmer)	48B313	C-100,101	3.9 mmfd. 10%, N1500 ±250 PPM; ceramic	47D20V039C
R1 R83-C f C125-F C124-F	C-5,17,36,87,128,132	46BR473L2	C-103,104,106	310 mmfd. 2%, N80, 500 V.; ceramic	47X45LG311G
	C-6	46BR103L6	C-105	68 mmfd. 1%, N150, 500 V.; ceramic	47X32PG680F
	C-7,19,40,41,43,53,57,62,67,76,78,83,86,140,142,143	46BR473L6	C-108	5.1 mmfd. ± .5 mmfd., N750, 500 V.; ceramic	47X20UJ051D
	C-8,30,91,145,146	47A242	C-109	117 mmfd. 10%, N150 ± 30 PPM, 500 V.; ceramic	47B440
	C-9	47X20UK150K	C-110,115	140 mmfd. 1%, NPO, 500 V.; ceramic	47X35CG141F
	C-10,13	47B403-5	C-112	10 mmfd. 10%, N470, 500 V., ceramic	47X20TH100F
	C-11-12	44C436	C-113	12 mmfd. 10%, N470, 500 V.; ceramic	47X20TH120K
	C-14-15-16,26-27-28	44C435	C-116	1.0 mmfd. 10%, N1500 ± 250 PPM, 500 V.; ceramic	47D20V010B
	C-18,37,38,39,88,121,122,144	47A224	C-118	1.0 mmfd. 10%, N750, 500 V., ceramic	47X20UJ010B
	C-20	47X20UJ150K	C-119	.047 mfd. 10%, 600 V.; molded paper	46BR473E6
	C-21	47X20UJ033C	C-120	10 mfd. 10%, 150 V., electrolytic	45A097
	C-22,147	47X20CG150K	C-123A-B-C-D	30 mfd. 450 V., 10 mfd. 450 V., 20 mfd. 25 V., electrolytic	45A041
	C-23-25-29	44C440	C-126,137	.022 mfd. 20%, 200 V., molded paper	46BR223L2
	C-24	47X20CG200K	C-127	68 mmfd. 10%, NPO, 500 V.; ceramic	47X25CK680K
SI	C-31,117	47X20UJ101K	C-129,133	.022 mfd. 20%, 600 V., molded paper	46BR223L6
PI	C-32,33,35	47X30B472K	C-130	220 mmfd. 10%, 500 V., silver mica	47X20D221K
	C-34	47B403-4	C-131	560 mmfd. 5%, 500 V., silver mica	47X20E561J
	C-42	47CA20A101K	C-134	1500 mmfd. 10%, 500 V.; silver mica	47X30D152K
	C-44,46,54,56,64,66,79,81,84	47X20E391J	C-135	.22 mfd. 20%, 600 V., molded paper	46BR224L6
	C-45,55,80	47B403-3	C-136	470 mmfd. 10%, 500 V., mica	47X20A471K
	C-47,85,124,125	47CA20A221K	C-138	10 mfd. 50 V., electrolytic	45B211
	C-48,49,58,59,68,69,74,75	46BR332E4	C-139	.033 mfd. 20%, 600 V.; molded paper	46BR333L6
	C-50,60,70,72	46BR473E2	C-141	680 mmfd. 10%, 500 V.; mica	47X20A681K
	C-51,61,71,73	46BR103E4	RESISTORS		
	C-52,63,77,82	46BR224L2	R-1,2,73,100	470,000 ohms 10%, 1/2 W.	23X20X474K
	C-65	47B403-0	R-3,11	22 ohms 10%, 1/2 W.	23X20X220K
	C-89	44B437	R-4,12,102	100 ohms 10%, 1/2 W.	23X20X101K
	C-90	47X20B151K	R-5	68,000 ohms 10%, 1 W.	23X30X683K
	C-92	47D20W047C	R-6,77,80	10 ohms 10%, 1/2 W.	23X20X100K
	C-93,99,102,107,111,114	48B316	R-7,16,28,34,49,58,67,93,99,103,104	2200 ohms 10%, 1/2 W.	23X20X222K
			R-8	33 ohms 10%, 1/2 W.	23X20X330K
			R-9	500 ohms, variable ("S" Meter Adj.)	25C022
			R-10,22,23,24,25,26,27,75,95	100,000 ohms 10%, 1/2 W.	23X20X104K
			R-13	18,000 ohms 10%, 1/2W	23X20X183K
			R-14,79	1000 ohms 10%, 1/2W	23X20X102K
	N neg temp coef	NPO - zero temp. coef		PPM parts/million/°C	

SERVICE PARTS LISTS (Cont.)

Schematic Symbol	Description	Hallcrafters Part Number	Schematic Symbol	Description	Hallcrafters Part Number
RESISTORS (Cont.)			COILS AND TRANSFORMERS (Cont.)		
R-15,21,33,97,107	8200 ohms 10%, 1/2 W.	23X20X822K	L-25,26,27	Choke, RF, red	53B008
R-17	2.2 megohms 10%, 1/2 W.	23X20X225K	L-28	Coil, AVC amplifier	50C612
R-18	2700 ohms 10%, 1/2 W.	23X20X272K	L-29	Choke, filter; 9H, 135 ma, 260 ohms DC	56C163
R-19	120,000 ohms 10%, 1/2 W.	23X20X124K	L-30	Choke, RF; blue	53B009
R-20,81,94	47 ohms 10%, 1/2 W.	23X20X470K	L-31	Coil, BFO (with shield)	54B050
R-29,78	22,000 ohms 10%, 1/2 W.	23X20X223K	L-32	Coil, BFO amplifier	51B1746
R-30	120,000 ohms 10%, 1/2 W. or 330,000 ohms 10%, 1/2 W. (see schematic)	23X20X124K	T-1,3	Transformer, IF; 2075 KC	50C611
R-31,68,87,92	1 megohm 10%, 1/2 W.	23X20X334K	T-2,4	Transformer, IF; 1550 KC	50C603
R-32,47,56	220 ohms 10%, 1/2 W.	23X20X105K	T-5	Transformer, 2nd conv. osc.	50C602
R-35,41,50,59	56 ohms 5%, 1/2 W.	23X20X221K	T-6,7,8,9	Transformer, IF; 50 KC (1st and 2nd interstage)	50C601
R-36,42,51,60	180 ohms 5%, 1/2 W.	23X20X560J	T-10	Transformer, IF; 50 KC (3rd interstage primary)	50C613
R-37,38,43,44,52,53,61,62	330 ohms 5%, 1/2 W.	23X20X161J	T-11	Transformer, IF; 50 KC (3rd interstage secondary)	50C614
R-39,45,54,63	820 ohms 5%, 1/2 W.	23X20X331J	T-12,13	Transformer, IF, 50 KC (detector)	50C615
R-40,46,55,64	16,000 ohms 5%, 1/2 W.	23X20X821J	T-14	Transformer, power, for Model SX-88	52C288
R-48,57,66	39,000 ohms 10%, 1 W.	23X20X163J		for Model SX-88U	52D295
R-65	180 ohms 10%, 1/2 W.	23X30X393K	T-15	Transformer, audio output	55C213
R-69	27,000 ohms 10%, 1/2 W.	23X20X181K			
R-70,76	180,000 ohms 10%, 1/2 W.	23X20X273K			
R-71	68,000 ohms 10%, 1/2 W.	23X20X184K			
R-72	4700 ohms 10%, 1/2 W.	23X20X683K			
R-74	3300 ohms 10%, 1/2 W.	23X20X472K			
R-82	10,000 ohms, variable (Sensitivity)	23X20X332K			
R-83	10,000 ohms, variable (Monitor)	25B1058			
R-84,90	330,000 ohms 10%, 1/2 W.	25B1062			
R-85	4000 ohms 5%, 10 W; wirewound	23X20X334K	S-1A-B-C	Switch assembly, Band Selector, antenna section and 1st RF amp. grid	62C076
R-86	6.8 ohms 10%, 1 W.	24BC402D	S-1D-E	Switch assembly, Band Selector, 1st RF amp. plate and 2nd RF amp. grid	62C077
R-88	47,000 ohms 10%, 1/2 W.	23X30X068K	S-1F-G	Switch assembly, Band Selector, 2nd RF amp. plate and 1st mixer grid	62C077
R-89	82,000 ohms 10%, 1/2 W.	23X20X473K	S-1H-I	Switch assembly, Band Selector, 1st conv. osc. grid and cathode	62C078
R-91	1.5 megohms 10%, 1/2 W.	23X20X823K	S-1J	Switch section, Band Selector; 1st mixer plate	62B075
R-96	270 ohms 10%, 1/2 W.	23X20X155K	S-1K	Switch assembly, Band Selector; 2nd conv. osc. cathode and 2nd RF amp. cathode	62B079
R-98	33,000 ohms 10%, 1 W.	23X20X271K	S-2	Switch assembly, BAND WIDTH	60D561
R-101	1 megohm, variable (Volume); includes on-off switch S7	23X30X333K	S-3	Switch assembly, RESPONSE	60C565
R-105,106,109,110	220,000 ohms 10%, 1/2 W.	25B606	S-4,5	Switch, spst toggle; AVC ON-OFF and CAL OFF-ON	60A138
R-108	220 ohms 10%, 2 W.	23X20X224K	S-6,9	Switch, dpdt toggle, REC-STANDBY and ANL OFF-ON	60B575
R-111	10,000 ohms 10%, 1/2 W.	23X40X221K	S-7	Switch, power off-on (part of Volume control R101)	-----
R-112	4700 ohms 10%, 2 W.	23X20X103K	S-8	Switch, toggle, dpdt center off (CW-AM-SSB)	60B568
		23X40X472K			
COILS AND TRANSFORMERS			JACKS, PLUGS AND SOCKETS		
L-1	Coil, antenna, band 6	51B1726	J-1,3	Jack, single pin, IF OUTPUT and PHONO	36A041
L-2	Coil, antenna; band 5	51B1727	J-2	Jack, PHONES	36B004
L-3	Coil, antenna; band 4	51B1728	PL-2	Plug, octal; AC jumper	35A003
L-4	Coil, antenna, band 3	51B1729	SO-1	Socket, AC ACCESSORY	10B015
L-5	Coil, antenna, band 2	51B1730	SO-2	Socket, octal; POWER SOCKET	6B296
L-6	Coil, 1550 kc trap	51B1747	SO-3	Socket, crystal	6A482
L-7	Coil, RF; band 6	51B1732		Socket, pilot lamp; for "S" meter (with leads)	6A262
L-8	Coil, RF; band 5	51B1733		Socket, pilot lamp; for tuning dials (with leads)	86B157
L-9	Coil, RF; band 4	51B1723		Socket, tube, octal	6B296
L-10	Coil, RF; band 3	51B1724		Socket, tube; 9 pin miniature (ceramic)	6B499
L-11	Coil, RF; band 2	51B1725		Socket, tube, 9 pin miniature (mica filled)	6B500
L-12	Coil, antenna; band 1	51B1731		Socket, tube, 7 pin miniature	6B505
L-13	Coil, mixer, band 6	51B1732			
L-14	Coil, mixer, band 5	51B1733			
L-15	Coil, mixer; band 4	51B1734			
L-16	Coil, mixer, band 3	51B1735			
L-17	Coil, mixer; band 2	51B1736			
L-18	Coil, mixer; band 1	51B1737			
L-19	Coil, oscillator, band 6	51B1717			
L-20	Coil, oscillator, band 5	51B1718			
L-21	Coil, oscillator, band 4	51B1719			
L-22	Coil, oscillator, band 3	51B1720			
L-23	Coil, oscillator; band 2	51B1721			
L-24	Coil, oscillator; band 1	51B1722			

SERVICE PARTS LISTS (Cont.)

Schematic Symbol	Description	Hallcrafters Part Number	Schematic Symbol	Description	Hallcrafters Part Number
TUBES AND DIAL LAMPS					
V-1,10	6CB6: 1st RF Amp, AVC Amp	90X6CB6			
V-2,4,6,7,8 16,20	6BA6: 2nd RF Amp, 2nd Mixer, 1st 50 KC IF Amp, 2nd 50 KC IF Amp, 3rd 50 KC IF Amp, BFO Amp, Xtal Cal.	90X6BA6			
V-3	6U8: 1st Oscillator-Mixer	90X6U8			
V-5	12AT7: 2nd conv. oscillator	90X12AT7			
V-9	6AL5: Detector and ANL	90X6AL5			
V-11	12AU7: AVC Rect. and 50 KC Cath. Fol.	90X12AU7			
V-12	12AX7: Audio Amp and Phase Inv.	90X12AX7			
V-13,14	6V6GT: Audio Output	90X6V6GT			
V-15	6C4: BFO	90X6C4			
V-17	5U4G Rectifier	90X5U4G			
V-18	OD3: Voltage Regulator	90XOD3			
V-19	4H4: Current Regulator	90X4H4			
LM-1,2	Lamp, pilot; type 44	39A003			
LM-3	Lamp, pilot; type 47	39A004			
MISCELLANEOUS					
	Belt, drive; Band Selector	14B374			
	Cabinet, complete	41X25313			
	Clip, gang shield; top section	76B148			
	Clip, gang shield; bottom section	76B149			
	Conn'g flexible (for Band Selector shaft)				
	3-5/8" overall	29B222			
	3-1/8" overall	29B224			
X-1	Crystal, 1500 KC	19B1890			
X-2	Crystal, 2125 KC	19B1891			
X-3	Crystal, 100 KC	19B1886			
	Detent, Band Selector switch	62C073			
	Dial, band spread tuning	83D466			
	Dial, main tuning	83D470			
	Dial pointer assembly	41C25327			
	Escutcheon, front panel	7D466			
	Foot, mtg.; rubber	16A029			
F-1	Fuse, 3 amp 250V; type 3AG	39A301			
	Gear drive assembly, complete	41X25311			
	Glass, band spread tuning dial	22B413			
	Glass, main tuning dial	22B412			
MISCELLANEOUS (Cont)					
	Grommet, rubber, "S" meter	16B362			
	Grommet, rubber, tuning gang rear support	16A180			
	Holder, fuse	6A451			
	Insignia, "h"	7B485			
	Knob assembly, MAIN TUNING and BAND SPREAD TUNING	41B25314			
	Calibrated plate (0-100)	83B454			
	Knob, phenolic	15B693			
	Spring	75B294			
	Button plug	17B138			
	Hub	77B717			
	Knob, ANTENNA TRIMMER	15A061			
	Knob, BAND SELECTOR	15C743			
	Knob, BAND WIDTH	15B679			
	Knob, LOCK	15B699			
	Knob, PITCH	15B677			
	Knob, pointer set	15B676			
	Knob, RESPONSE	15B678			
	Knob, SENSITIVITY and VOLUME	15A097			
NE-2	Lamp, neon glow, GE type NE2, 1/25 W., 65V AC starting	39A012			
PL-1	Line cord and plug	87A3644			
	Logging scale, tuning dial	83C475			
	Lock, line cord	76A397			
	Meter, "S", 0-5 ma	82C248			
M-1	Panel, front	68D241			
	Retainer, tube, V-17	76A1032			
	Shaft, extension, Antenna Trimmer	74B635			
	Shaft, Band Selector 10-3/4" long	74B636			
	11-1/4" long	74B702			
	Snap-in tri-mount	5A006			
	Terminal board, steatite, 3 post type lugs (used as tie strip for oscillator padders)	41X25346			
	Terminal strip, antenna (A1-A2-G)	88B935			
	Terminal strip, speaker (G-3.2-8-500)	88B936			

VOLTAGES

Voltage readings taken under the following conditions:

1. Line voltage—117 volts, 60 cycles AC.
 2. Antenna terminals shorted, Band Selector at Band 1 (355—1.7 MC); Specificity at "0", Reg. Standby at "0"; CW-AM-SSB at "AM", AML and CAL at "OFF", AVC at "On", and Band Width at "10 KC".
 3. All voltages measured between tube socket terminals and chassis unless otherwise specified.
 4. DC voltages measured with VTVM; AC voltages with 1000 ohm per volt meter.
 5. Voltage readings for V20 taken with CAL switch at "On".
 6. Voltage readings for V1E and V1B taken with CW-AM-SSB switch at "CW" and "SSB".
 7. Voltage readings shown for V5 are for Bands 1, 4, 5, and 6. For Band 2, the readings of the two triode sections are reversed.
- ⊙ Voltage varies depending on value of screen dropping resistor R32. Use upper value if R32 is 120K, lower value if R32 is 330K.
- ◆ Voltage varies with setting of tuning gear.

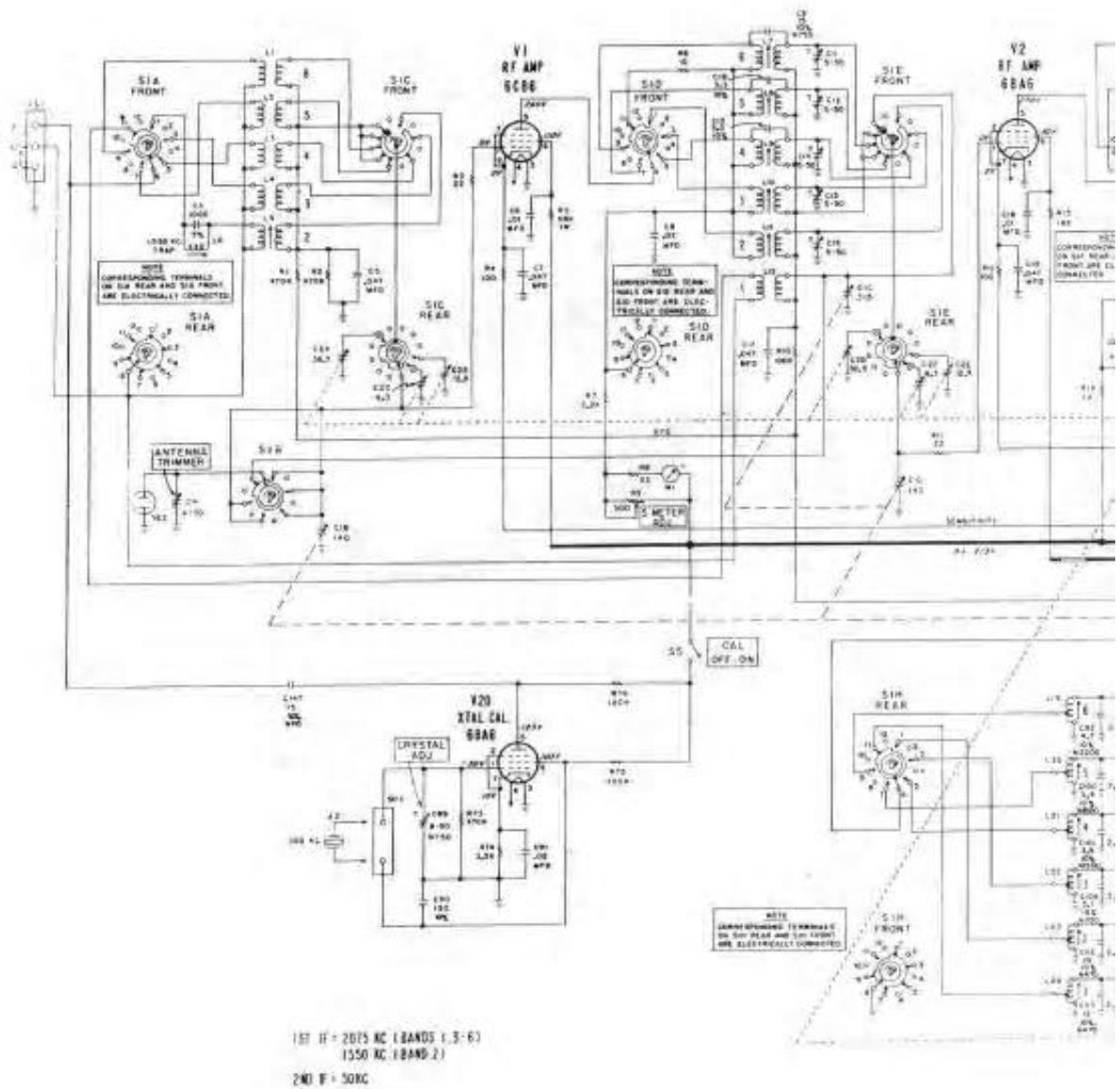

NOTES

1. Resistor values in ohms and capacitor values in MMF unless otherwise specified.
2. Unless otherwise specified, resistors are 1/2 watt and 10% power tubular capacitors are 20% and ceramic disc capacitors are 10%.
3. Terminal arrangement shown for switches S1, S2, and S3 is as viewed from front of set.
4. Band Selector switch S1 shown in Band 1 position (535-17-MC).
5. Band Width switch S2 shown in "10 KC" position.
6. Response switch S3 shown in "Sens Boost" position.
7. Values and tolerances are nominal and variations may be found. It is recommended that the value of any replacement correspond to the nominal value of the part being replaced.

⊕ 250K on early production sets. When servicing 2nd converter sub-chassis, check value of R10. If 250K, remove and replace with 120K resistor.

⊕ Check.

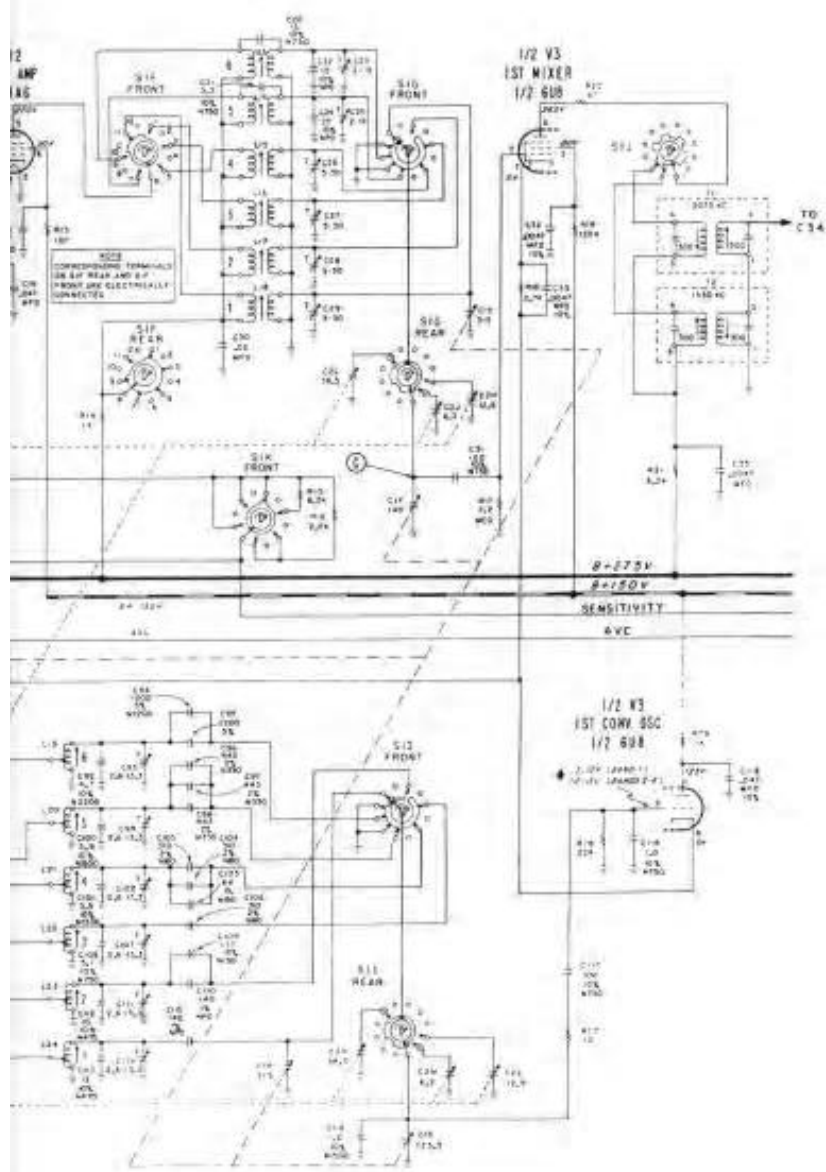

2ND CONVERTER SUB-CHASSIS

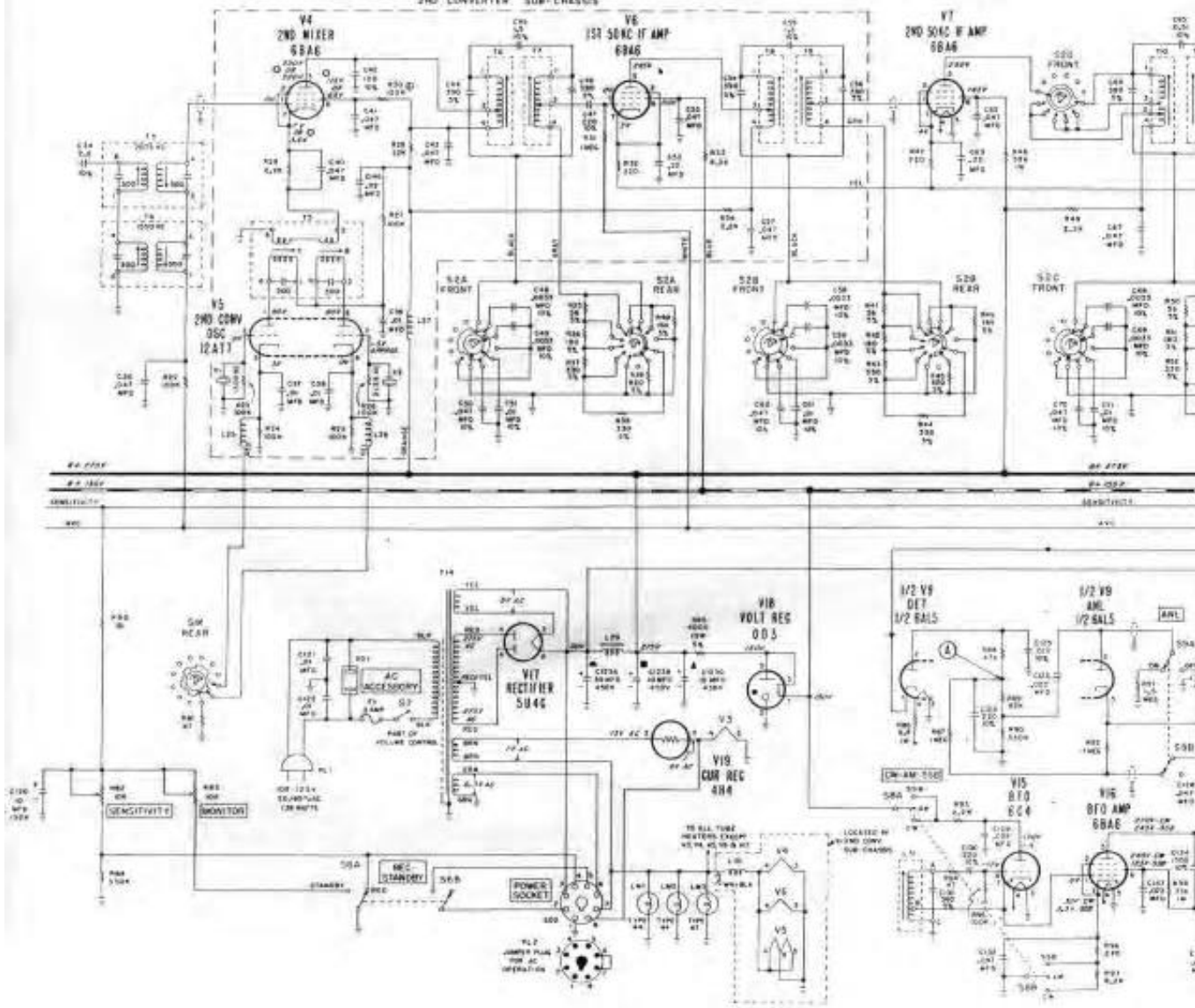

MODELS SX-88 & SX-88U RUN 1

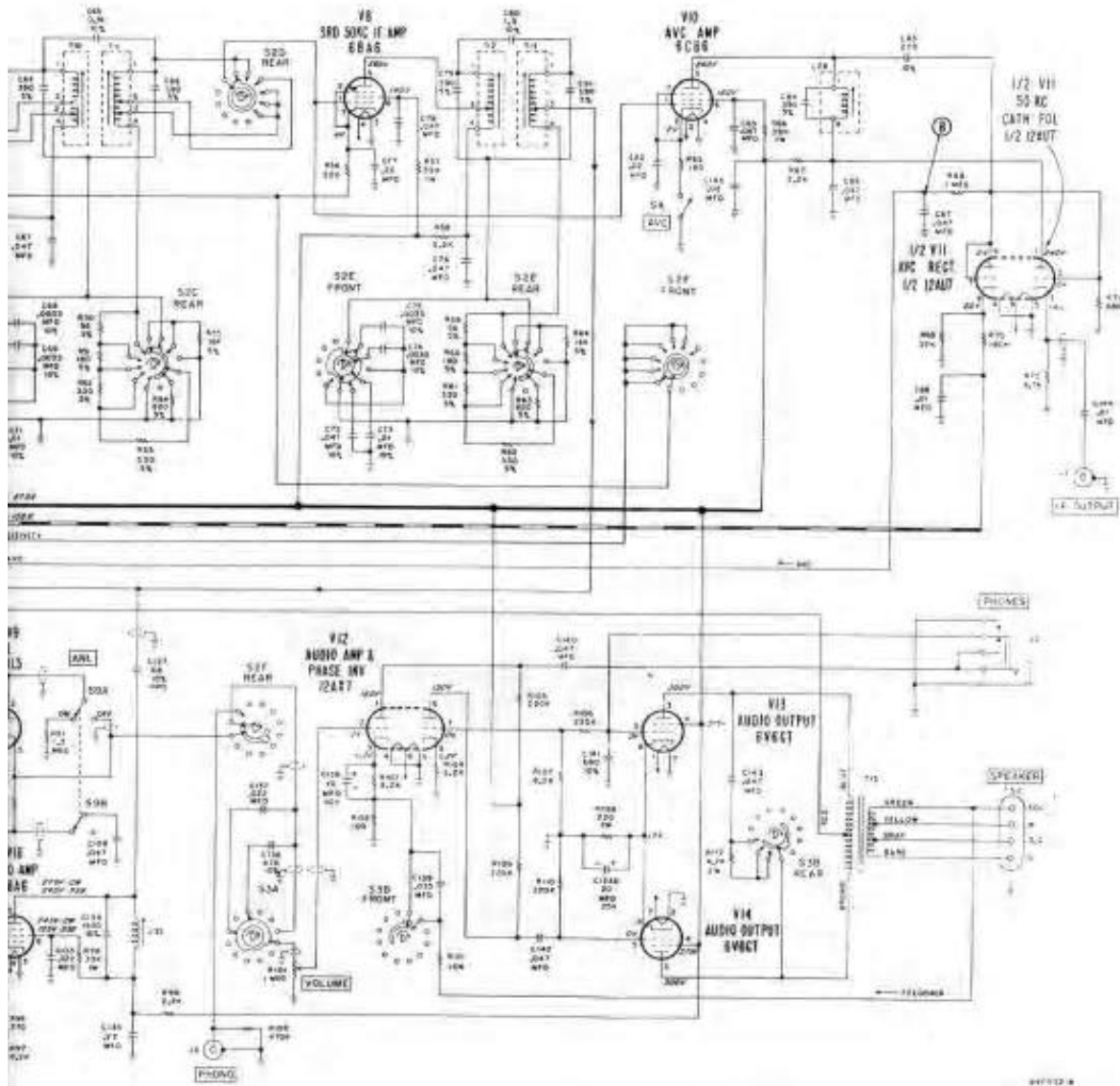

Fig. 20. Schematic Diagram