

1ST NAVMARCORMAR REGION LIBRARY
LOU AMSTUTZ - NNNOASI-9/NNNOABU
1816 S. KOHLER RD.
ORRVILLE, OHIO 44667 *HAM-2*

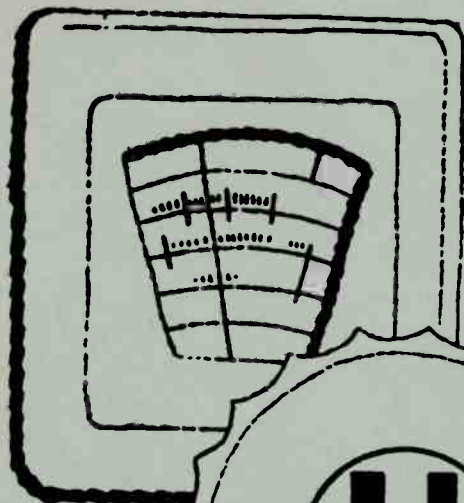

**HQ-180
SERIES
COMMUNICATIONS
RECEIVERS**

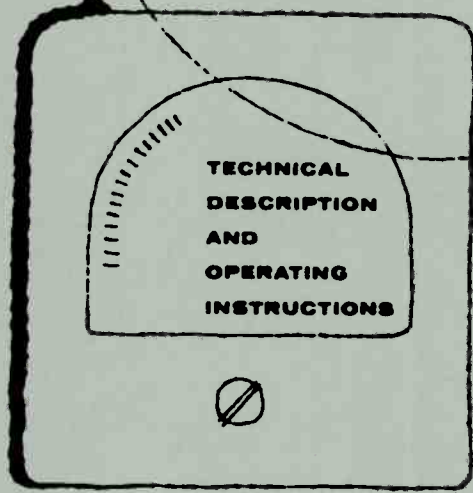

HAMMARLUND

HAMMARLUND MANUFACTURING COMPANY, INC.
A Giannini Scientific Co.
73-88 Hammarlund Drive, Mars Hill, North Carolina
Export Department: 13 East 40th Street, New York 16, N. Y.

52787-1

In order that the Hammarlund Manufacturing Company may more effectively process customer complaints and warranty, as well as non-warranty repairs and modifications, a Customer Service Group has been established at our factory, located in Mars Hill, North Carolina.

The scope of this group will include all direct correspondence with the customer and with warranty repair stations, jobbers and representatives. It will also include factory repair facilities.

As you can see, this is a true "service" organization, interested only in satisfying the customer.

In the future, please address all correspondence of this nature to:

Hammarlund Manufacturing Company
Mars Hill, North Carolina

Attention: Customer Service

THE HQ-180 AND 180-A SERIES OF COMMUNICATIONS RECEIVERS

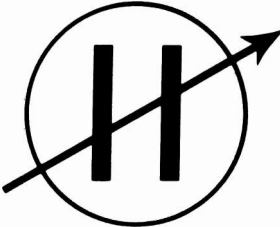

THE HAMMARLUND 180 AND 180-A SERIES OF
COMMUNICATIONS RECEIVERS

CONTENTS OF INSTRUCTION AND SERVICE MANUAL

Specifications	Page 3
Circuit Description	Page 6
Installation	Page 9
Operation	Page 17
Service and Maintenance	Page 24
Removing and Replacing The Chassis	Page 35
Removing and Replacing The Front Panel	Page 37
Alignment Procedure	Page 45
Tube Socket Voltages	Pages 58, 60, 62, 64
Tube Socket Resistances	Pages 59, 61, 63, 65
Parts List	Page 66
Schematic Diagram	Page 76

HQ-180 AND 180-"A" SERIES SPECIFICATIONS

Frequency Range Covered:

.54-1.05mc/s; 1.05-2.05 mc/s; 2.05-4.04 mc/s; 4.0-7.85 mc/s; 7.85-15.35 mc/s; 15.35-30.0 mc/s.

Bandsread Calibration:

Dial markings every 5 kc/s on 15, 20, 40 and 80 meter bands; every 10 kc/s on 10 meter band; plus arbitrary 0-100 logging scale.

Maximum Audio Output:

1.0 Watt (Undistorted)

Passband Tuning Range:

plus/minus 3 KCS with calibration every 1 KC. 8:1 vernier tuning ratio.

Output impedance:

3.2 Ohms (E1A Standard) plus 500 Ohms.

AVC Action:

Operates on RF and 3 1F stages. Provides fast charge--adjustable discharge smooth acting AVC. Delayed AVC applied to the RF stage. Better than .001 second attack time and .01 - .1-1 second decay time. Off position.

Adjustable Selectivity and Selectable Sidebands:

6 db bandwidths Upper sideband--1-2-3 kcs
Lower sideband--1-2-3 kcs Both sidebands--
.5-2-4-6 kcs

Sensitivity:

An average of 1.5 microvolts produces 10:1 signal-to-noise ratio on AM approximately .7 uv on CW and SSB.

Antenna Input:

50 to 600 ohms; balanced or unbalanced.

Antenna Compensator:

Permits compensation for loading effects of various type antennas, or balanced transmission line.

Beat Frequency Oscillator:

Variable from zero beat plus/minus 2 kcs plus fixed position for SSB.

Slot Filter:

Range plus/minus 5 kcs of center frequency. Attenuation over plus/minus 5 kcs range provides over 40 db. Calibrations every 1 kc. Maximum attenuation using slot depth control is 60 db. 8:1 vernier tuning ratio.

Tube Complement:

6BZ6	RF Amplifier
6BE6	1st Converter
6C4	HF Oscillator
6BE6	2nd Mixer-Crystal Osc.
6BA6	455 kc Gate
6BA6	455 kc 1F Amp.
6BE6	3rd Mixer-Variable Osc.
6BA6	60 kc 1F Amp.
6BA6	60 kc 1F Amp.
6BV8	60 kc 1F amp. AVC-AM Det.
12AU7	SSB Product Detector
6AL5	Noise Limiter
12AU7	BFO-"S" Meter Amplifier
6AV6	1st A F Amp. - Delayed AVC Clamp
6AQ5	Audio Power Output
OA2	Voltage Regulator
6BZ6	Crystal Calibrator
6CW4	Crystal Oscillator

Semiconductor Complement:

Rectifier -- Two 800 P.I.V. at 1/2 amp.

Power Supply:

105-125 Volts 50-60 cps. a.c. power consumption. 120 watts.

"S" Meter:

Calibrated 1 to 9 in steps approximately 6 db. Also includes db scale, above 5-9 to plus 40 db. (Meter deflects on all types of signals.)

Noise Limiter:

Adjustable series type provides both positive and negative clipping.

Front Panel Equipment:

Main Tuning
Bandspread Tuning
Vernier or Bandpass Tuning
Sensitivity (RF Gain):
on/off switch
Selectivity: 0.5-1-2-3 Kcs.
(per sideband)
Sideband: Upper-lower-both
Audio Gain
Antenna Compensator
Tuning Range (Band Selector)
Function Switch: AM-SSB-CW
Slot Freq. Calib.
CW Tone (BFO Pitch)
Noise Limiter, adjustable
-on/off switch
AVC, off-slow-medium-fast
Send-Receive-Calibrate
Phone Jack
"S" Meter
Dial Scale reset

Rear Panel Equipment:

Terminals for speaker connections
3.2 ohm for voice coil
500 ohm for line or VOX

Accessory socket for preamp, Q-multiplier or converter. System socket for simplified associated transmitter/receiver control.

S-meter controls.

Antenna input terminals plus SO239.

Dimensions:

10-1/2" H x 19" W x 13" D
Wt. 38 lbs.
Shipping Wt. 45 lbs.

HQ-180AX

Universal model of the HQ-180A receiver with provisions for 11 fixed-frequency crystal controlled channels. Six of the crystals are easily interchangeable from the front panel--the balance are located within the cabinet but are readily accessible from the trap-door top. 3 kc vernier tuning control permits compensation for minor frequency variations of the crystals.

24 HOUR CLOCK-TIMER

Combination clock and automatic timer. Aids in meeting prearranged schedules. Optional extra.

IF AMPLIFIER The 3035 KCS and 455 KCS IF amplifiers provide eight tuned circuits in three stages of amplification. Six tuned circuits in the three-stage 60 KCS amplifier provide either the second or third conversion, depending upon the operating band. All IF circuits employ iron-core permeability-tuned transformers for the high performance and retention of alignment accuracy. The 60 KCS amplifier selectivity is controlled from the front panel by seven positions: 1-2-3 KCS on either sideband, and .5-2-4-6 KCS on both sidebands. The skirt selectivity of this system approaches that of the mechanical filter. A separate front panel switch is used to select upper, lower, or both sidebands, providing rapid, simple means of sideband selection.

SLOT FILTER The slot filter provides a notch of better than 60 db attenuation over the entire range of ± 5 KCS from the center IF (455 KCS) frequency. The slot filter control provides 40 db attenuation, plus an additional attenuation of up to 20 db obtainable by use of the slot depth control at a particular frequency. The 6 db width of the slot is approximately 1.5 KCS. Accurate frequency adjustment of the slot is obtained by means of an 8:1 vernier control. The slot filter circuit consists of a Bifilar "T" trap.

SEPARATE VERNIER TUNING ± 3 KCS vernier tuning allows extra-fine passband tuning between the 455 KCS IF and the 60 KCS IF for additional selectivity and easy tuning of the desired signal.

AVC An extremely fast-attack delayed AVC circuit is employed. A four position control on the front panel permits the selection of OFF-AVC or SLOW-MEDIUM-FAST AVC decay time for optimum results on various signals. The AVC is taken from the high selectivity 60 KCS IF.

S-METER Readings of signal strength and "on-the-point" tuning indications are provided on all types of signals by a high-response S meter circuit. The scale is calibrated to 40 db over S-9 and is factory-calibrated so a signal of approximately 50 microvolts reads S-9. Each S-unit indicates approximately a 6 db increase, equivalent to doubling the signal strength. S-meter is extremely effective on SSB and CW when using slow decay AVC.

AUDIO The HQ-180A features the exclusive Hammarlund Auto-Response which automatically adjusts the audio passband to best meet the receiving conditions. A (6AQ5) provides 1.0 watt for maximum undistorted output. The Auto-Response circuit employs controlled feedback which is decreased as the gain control is turned up, thus narrowing the audio passband. As the gain is decreased, the feedback increases, thus permitting a greater frequency response in the audio output. The result is crisper, easier to read sound on weaker signals, and broader, more realistic reproduction on stronger signals.

The audio output may be used with either earphones or loudspeaker. The phone plug automatically silences the speaker upon insertion. The Audio-Response permits tops in listening pleasure of AM, SSB, and CW reception.

HQ-180A DESCRIPTION

Starting with the front panel layout, the careful selection of high-reliability components, the craftsmanship of skilled technicians, and the addition of engineering leadership result in a receiver worthy of the Hammarlund name in quality and performance.

The HQ-180A offers the listener a practically endless combination of tuning techniques whereby reception of SSB/CW and AM/MCW may be achieved. Through the use of the vernier tuning, adjustable bandwidth, and the basic, precision front-end of the HQ-180A the user has full control over SSB signals as well as adjacent, or co-channel signals. If there's a signal to be received, the HQ-180A can ferret it out...

The HQ-180A is a "hot" receiver. It will provide 10 db signal-to-noise ratio at 1.5 uvolt AM or approximately .5 uvolt CW, or better depending on bandwidth. The front end provides continuous tuning .54 mc/s to 30 mc/s. The receiver is designed for use with a single wire flat top, a folded dipole, or doublet antenna.

CIRCUITRY The HQ-180 is an eighteen tube triple conversion superheterodyne receiver (double conversion, .54 to 7.85 megacycles) that has been designed to provide the best possible performance for reception of AM, SSB and CW signals. The most important performance characteristics of a communications receiver have been made adjustable by means of the front panel knobs.

The RF tuning system covers the following bands:

MAIN TUNING DIAL

.54 to	1.05 mc...	cal in	10 kc divs.
1.05 to	2.05 mc...	cal in	10 kc divs.
2.05 to	4.04 mc...	cal in	20 kc divs.
4.0 to	7.85 mc...	cal in	50 kc divs.
7.85 to	15.35 mc...	cal in	100 kc divs.
15.35 to	30.0 mc...	cal in	100 kc divs.

BAND SPREAD TUNING DIAL

Arbitrary scale	0 to 100 divs.
3.44 to	4.040 mc...	cal in 5 kc divs.
6.810 to	7.3 mc...	cal in 5 kc divs.
13.980 to	14.425 mc...	cal in 5 kc divs.
20.925 to	21.60 mc...	cal in 5 kc divs.
27.890 to	29.7 mc...	cal in 10 kc divs.

A built-in 100 kcs crystal calibrator provides marker signals at every 100 kcs on all bands for checking dial calibration accuracy.

The dial calibration reset knob enables you to adjust the frequency calibration to approach frequency meter standards on each amateur band.

Starting at the front-end, the HQ-180A utilizes a (6BZ6) tuned RF amplifier and a separate mixer (6BE6) and oscillator (6C4) for a high degree of stability. Advanced design and modern tube types account for the very high gain and low noise factor. Refer to page one for complete listing of the many possible functions and the complete tube lineup.

Low-loss, coil forms, and bandswitch wafers, plus temperature-compensating capacitors, and the application of regulated power to the oscillator circuit provide a high degree of stability.

TRIPLE CONVERSION The HQ-180A offers triple conversion with IF frequencies of 3035 KCS, 455 KCS, and 60 KCS, providing excellent rejection of image-response. The second IF is heterodyned with a crystal-controlled oscillator. The third IF is heterodyned with a high stability, adjustable oscillator which contains micro-accurate vernier tuning control, located on the front panel.

The HQ-180A Series differs from the 180 Series in the following respects:

1. The power supply is designed for 115/230 v. 50, 60 cycle AC operation. This applies to the power transformer T-30 and the new filament transformer T22.

2. A separate filament transformer is employed, T-22 in the schematic diagram. This transformer provides 24 hour a day operation of the heaters of the high frequency oscillator and first converter, to reduce initial warm up drift. In addition, this transformer also supplies the systems socket which is a new added feature. If the receiver is not to be operated for long periods (upwards of 3 days) the line cord should be removed from the socket.

3. A new accessory socket plus a systems socket has been added. The accessory socket may be used to power most 6 and 2 meter converters. The systems socket will be found convenient when the HQ-180AX series of receiver is employed in conjunction with a transmitter since all of the necessary VOX anti trip and/or relay connections are available from this socket. This also provides a rapid disconnect without the need of tools once the installation has been completed properly. A Coordination Cable is available for use with the HQ-180A or HQ-170A series of receivers designed primarily for use with the HX-50 Hammarlund transmitter but useable with other transmitters as well. This is part #PL39286-G1 at \$8.50.

4. A new three (3) position BFO switch is provided enabling the BFO to be in the off position, SSB, where the BFO is fixed for optimum SSB audio response with reference to the passband. The CW position enables the BFO to be adjusted plus or minus 2 KC thus providing the usual pitch control adjustment. For CW reception, the BFO should always be set plus or minus 500 cycles to 1000 cycles especially in the .5 KC selectivity position so as to prevent detuning of the desired signal for the desired pitch.

5. 3.2 ohms and 500 ohms output terminations are now provided for voice coil or line operation. The 500 ohm line termination will be found very advantageous for phone patch and improved anti trip operation of most VOX circuits.

6. The 5U4G tube formerly used in the HQ-180 has now been replaced with two (2) silicon diode rectifiers thus providing cooler operation and better regulation from the power supply.

7. The HQ-180AX series of receivers provides an 11 position fixed frequency crystal oscillator assembly which is factory installed in the panel space provided for the 24 hour clock timer. The knob on this assembly allows selection of normal variable frequency tuning or any one of eleven fixed frequencies crystal controlled. Six crystals are mounted on the front plate of the oscillator assembly and may be changed quite readily to shift frequency. The remaining

5 crystals are mounted behind the front panel on the oscillator box and may be changed by lifting the top cover of the cabinet. It is intended that the five inside crystals will be for commonly used channels not subject to being changed very often. The receiver can be zeroed into the channel frequency by manipulating the vernier tuning control on the front panel. This will correct for frequency discrepancy due to crystal tolerance and assure accurate "netting".

The use of the crystal controlled oscillator will permit the highly stable reception of signals on the eleven channels selected. The only operation required beside turning the selector switch to the desired crystal position is to turn the band switch to the required position and tune the main dial to the approximate frequency rocking the knob finally for maximum "S" meter indication.

In order to ensure proper operation the crystals should be ordered from your local authorized Hammarlund distributor.

The oscillator or actual crystal frequency for a given signal frequency shall be determined from the following:

<u>SIGNAL FREQUENCY</u> <u>RANGE mc</u>	<u>ADD IF -----</u> <u>FREQUENCY mc</u>	<u>SUBTRACT IF-</u> <u>FREQUENCY mc</u>	<u>MODE OF</u> <u>OPERATION</u>
.54 to 1.05 mc	.455000		Fundamental
1.05 to 2.05 mc	.455000		Fundamental
2.05 to 4. mc	.455000		Fundamental
4.0 to 7.85 mc	.455000		Fundamental
7.85 to 15.35 mc	3.035		Fundamental
15.35 to 20.662 mc	3.035		Fundamental
20.662 to 30.000 mc		3.035	2nd Harmonic

NOTE: WHERE LOW SIDE INJECTION IS SPECIFIED, HIGH SIDE INJECTION MAY BE USED AT REDUCED SENSITIVITY.

HQ-180A INSTALLATION

Your Hammarlund Receiver is designed to give you the very best results. A few minutes to be sure it is installed correctly is worth while. Even though we have developed the most sensitive circuitry to select and amplify the signal you want to hear, remember that it can work only on the RF you feed it from your antenna. It is to obtain the most satisfaction in its operation that we urge you to put up the best antenna system you can. The HQ-180A will work very well with a temporary wire strung out of a window, but only use this method while constructing or having constructed a proper antenna system. Finally, a good ground, serves many purposes; one, it eliminates tendencies towards AC hum pickup, often straying through homes or apartments; two, it minimizes atmospheric and man-made noise; three, it ensures a safe path for any voltage coming from a possible short or from an associated transmitter. When using an outside antenna, it is always best to install a lightning arrester. Such a device drains off the atmospheric charge in a safe manner, protecting you, and the Receiver.

Note that all of the Receiver connections are at the rear of the set, and that there are a variety of very useful terminal points, permitting a number of important system connections to be permanently attached in a neat manner. The illustrations below show you all of them, allowing you full freedom to use those that are most useful to you, whether you are only listening or are operating with a transmitter. The Accessory and System sockets, are all for special applications associated with reception, but not necessary for ordinary operation. The speaker and antenna connections are required in any case.

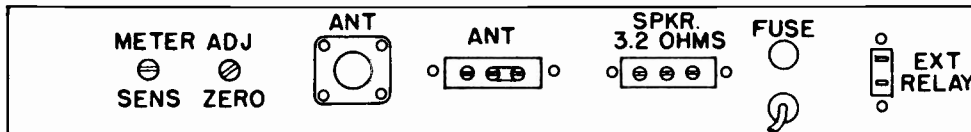

HQ-180 SERIES

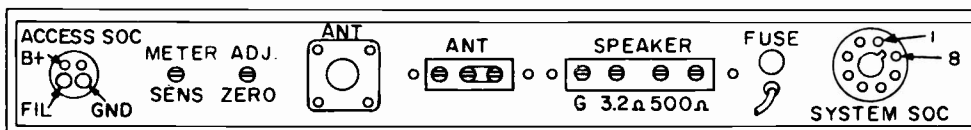

HQ-180A SERIES

RECEIVER REAR CONNECTIONS

Connect a suitable 3.2-ohm loudspeaker to the 3.2-ohm terminal screws as shown in the diagram. Use a Hammarlund S-200 Speaker for best results, but any equivalent speaker in a cabinet will operate satisfactorily. Do not place the speaker cabinet on top of the Receiver, because the HQ-180A is a very sensitive set, and speaker vibration can cause regenerative oscillation electronically, impairing reception. Note that a jack is provided in the lower left corner of the front of the Receiver for headphone plug insertion. The loudspeaker is automatically disconnected when the phone plug is inserted.

HEADPHONES

High impedance magnetic phones will usually be found satisfactory when the headphone jack is employed. The phones are deliberately mismatched to reduce the level into them. If more level or volume is desirable, low impedance phones may be employed. These may be any of the popular impedances such as 8, 16 or 24 ohms. If you do not have headphones and desire to purchase a pair, the low impedance type is suggested since it will always be possible to reduce the volume by making use of the audio volume control.

Another alternative, if high impedance phones are available, is to permanently connect these to the 500 ohm line output terminals on the rear of the receiver. These will provide more volume than the headphone jack since the headphone jack impedance is 3.2 ohms or the same as the speaker. ("A" Series only.)

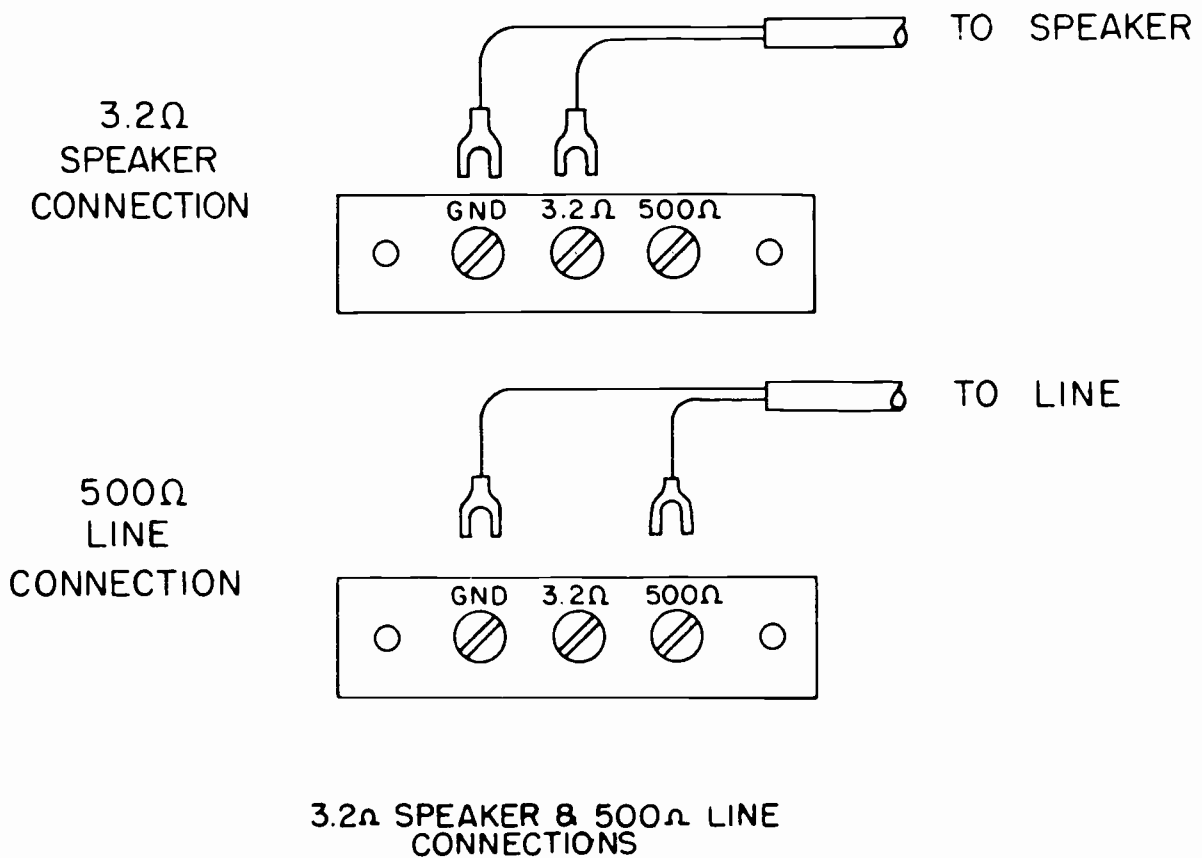

The Receiver connections for the antenna and ground are clearly illustrated on these pages, and a few hints are given for antenna installation, but the HQ-180A owner is urged to read a good antenna book to select the best type for his purpose. The Amateur Radio Relay League publishes this type of information. Its Antenna Book provides all you need to know about antennas for both reception and transmission. Other publishers produce equivalent books on this subject.

After selecting the antenna desired, consult the diagrams in this Manual to make the proper connections to the receiver. Following are some tips on antenna system selection and installation.

Either a single-wire or a balanced antenna may be used with the HQ-180A. The front panel antenna trimmer control is designed to permit a good match to almost all antenna systems of 50 to 600 ohms, balanced or unbalanced. The coaxial connector is intended to be used for 50-ohms types, the terminal strip for up to 300 ohms. While general coverage can be obtained from a short wire of 20 to 50 feet, much improved reception will be developed from an outdoor single-wire system of 50 to 150 feet in length. It is recommended that the antenna be isolated as much as possible from near-by objects, buildings, trees, etc., and that it be located at right angles to power lines or busy highways. This will minimize interference pickup from the lines or from passing vehicles.

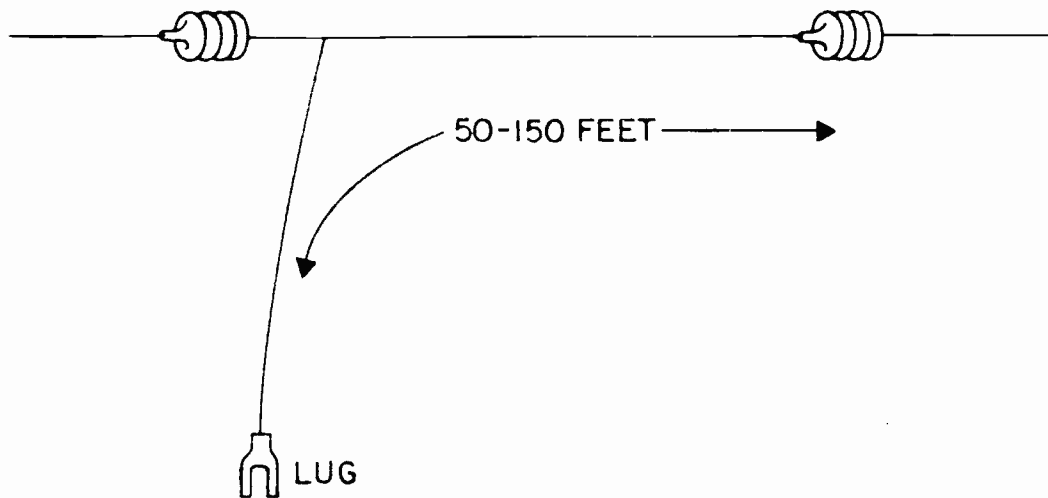

SINGLE WIRE ANTENNA

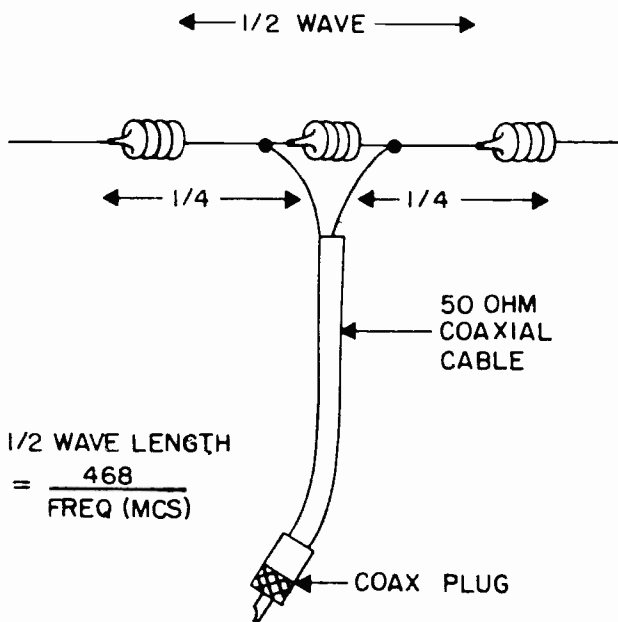

$$\frac{1}{2} \text{ WAVE LENGTH} = \frac{468}{\text{FREQ (MCS)}}$$

DIPOLE ANTENNA

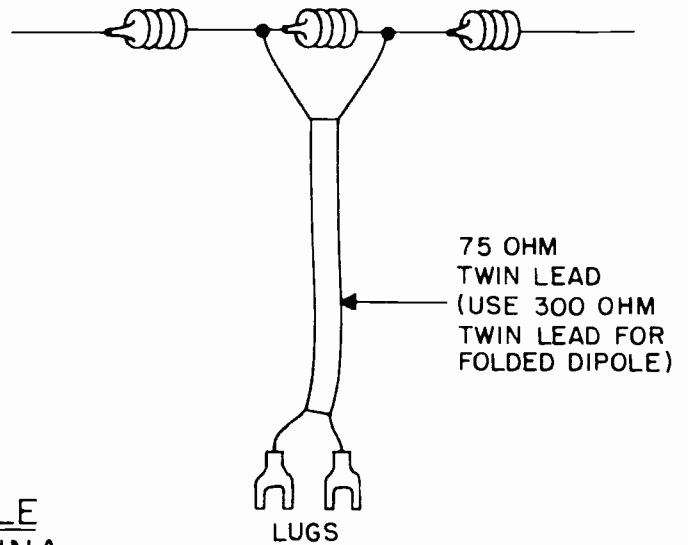

The first antenna connection illustration shows the simplest system. This arrangement provides good overall coverage, but if a particular band is intended to be used consistently, the use of a dipole tuned to that band is recommended. The illustrations show how such an antenna is made and what Receiver connections are necessary. For all antennas, the shielded or twin-lead methods are a decided improvement over the single wire to minimize man-made interference and noise signals. In especially noisy areas, this may be the only way to develop an acceptable signal.

Each of the antenna connection schemes require very little wiring complications or soldering technique. For those familiar with soldering, no trouble will appear. For those who have never soldered, it is recommended that some practice be obtained before attaching a plug to a shielded cable. However, the experience gained from work on even one hi-fit kit or radio is ample for this work. For convenience, some simple instructions in plug and cable installation are included in this book. Remember not to apply too much heat, just enough to allow solder flow. Excess heat will melt some plastic insulations, possibly causing a short between the center conductor and the shield.

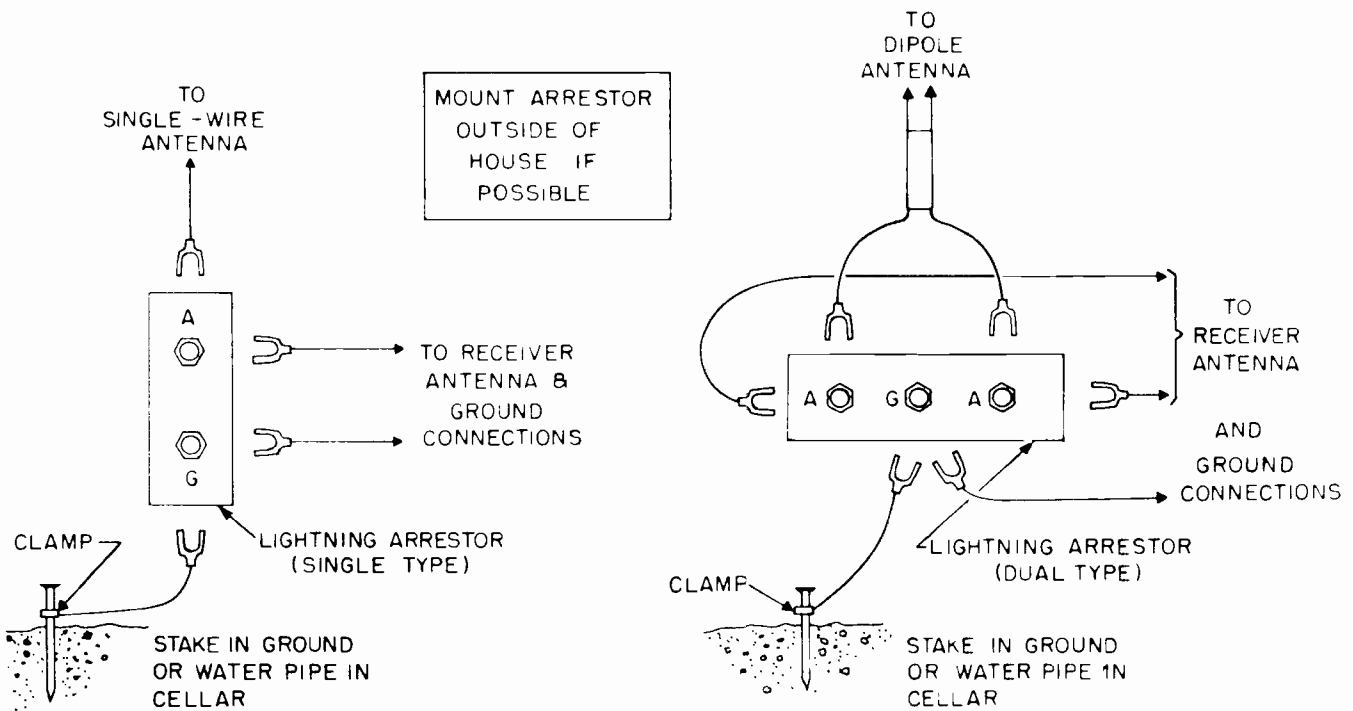

TYPICAL LIGHTNING ARRESTOR INSTALLATIONS

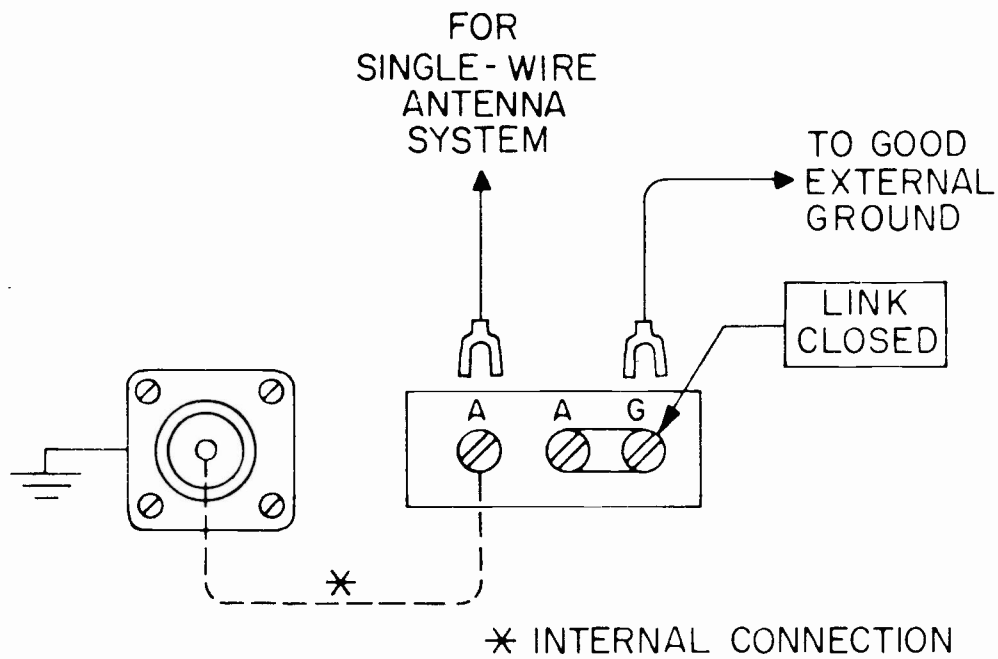

ANTENNA CONNECTIONS FOR SINGLE WIRE
ANTENNA

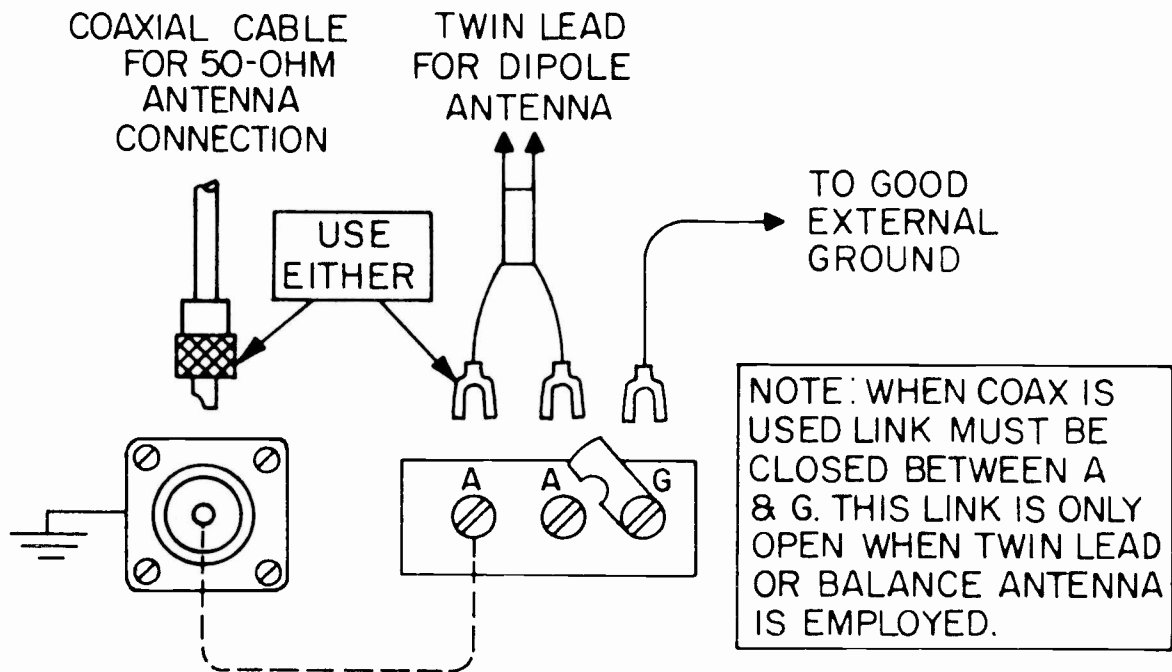

ANTENNA CONNECTIONS FOR DIPOLE
ANTENNA

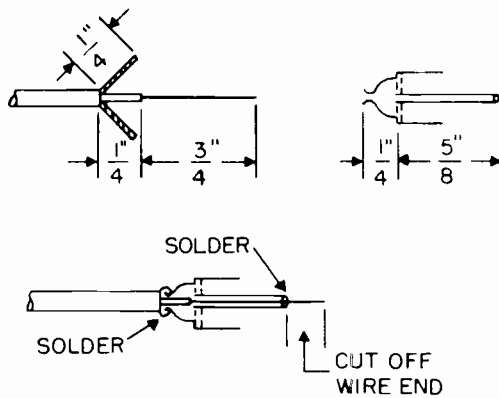

1. STRIP INSULATION.
2. CUT AND SPREAD SHIELD.
3. INSERT CABLE INTO PLUG, CENTER CONDUCTOR THRU PIN. SOLDER CENTER CONDUCTOR, CUT OFF EXCESS.
4. SOLDER SHIELD AROUND OUTER NECK OF BODY.

CAUTION: DO NOT USE TOO MUCH HEAT, CENTER CONDUCTOR INSULATION MELTS EASILY!

ATTACHING SHIELDED CABLE TO PHONO TYPE CONNECTOR

ASSEMBLY OF CABLES TO 83-1 SP PLUG USING ADAPTER 83-168 OR 83-185



CUT END OF CABLE EVEN. REMOVE VINYL JACKET $\frac{3}{4}$ ". SLIDE COUPLING RING AND ADAPTER ON CABLE.



FAN BRAID SLIGHTLY AND FOLD BACK AS SHOWN.

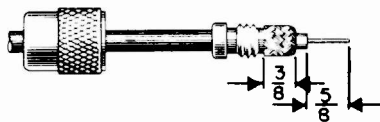

POSITION ADAPTER TO DIMENSION SHOWN. PRESS BRAID DOWN OVER BODY OF ADAPTER AND TRIM TO $\frac{3}{8}$ ". BARE $\frac{5}{8}$ " OF CONDUCTOR. TIN EXPOSED CENTER CONDUCTOR.

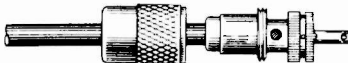

SCREW PLUG SUB-ASSEMBLY ON ADAPTER. SOLDER BRAID TO SHELL THROUGH SOLDER HOLES. USE ENOUGH HEAT TO CREATE BOND OF BRAID TO SHELL. SOLDER CONDUCTOR TO CONTACT.

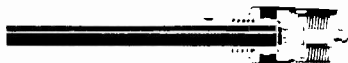

FOR FINAL ASSEMBLY, SCREW COUPLING RING ON PLUG SUB-ASSEMBLY.

ASSEMBLY OF CABLES TO 83-1 SP PLUG

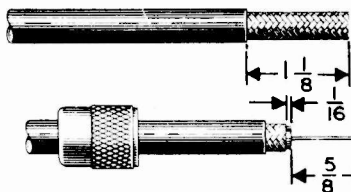

CUT END OF CABLE EVEN. REMOVE VINYL JACKET $\frac{1}{8}$ ".



BARE $\frac{5}{8}$ " OF CENTER CONDUCTOR. TRIM BRAIDED SHIELD. SLIDE COUPLING RING ON CABLE. TIN EXPOSED CENTER CONDUCTOR AND BRAID.



SCREW THE PLUG SUB-ASSEMBLY ON CABLE. SOLDER ASSEMBLY TO BRAID THROUGH SOLDER HOLES. USE ENOUGH HEAT TO CREATE BOND OF BRAID TO SHELL. SOLDER CENTER CONDUCTOR TO CONTACT.



FOR FINAL ASSEMBLY SCREW COUPLING RING ON PLUG SUB-ASSEMBLY.

Using 6 and 2 meter converters with the HQ-180 and "A" series receivers

When building or purchasing a converter for 6 or 2 meters, we recommend using an IF frequency of 10.0 to 14.0 mc/s. In the "A" series of receivers the accessory socket may be used for convenience in supplying power to the converter. Consult the Accessory Socket Connections Diagram for the proper plug wiring.

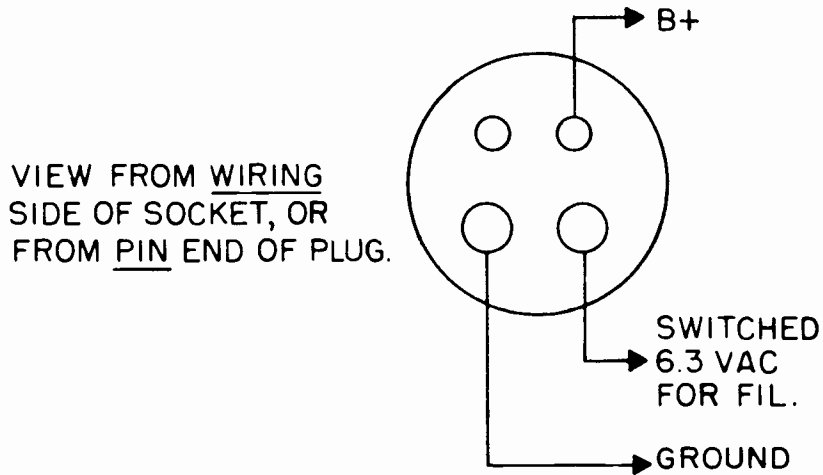

ACCESSORY SOCKET CONNECTIONS

The system socket connections provide for a variety of uses, depending upon the transmitter system installed. (Compatibility with Hammarlund HX-50 or HX-500 Transmitters included. See their instruction manuals for details).

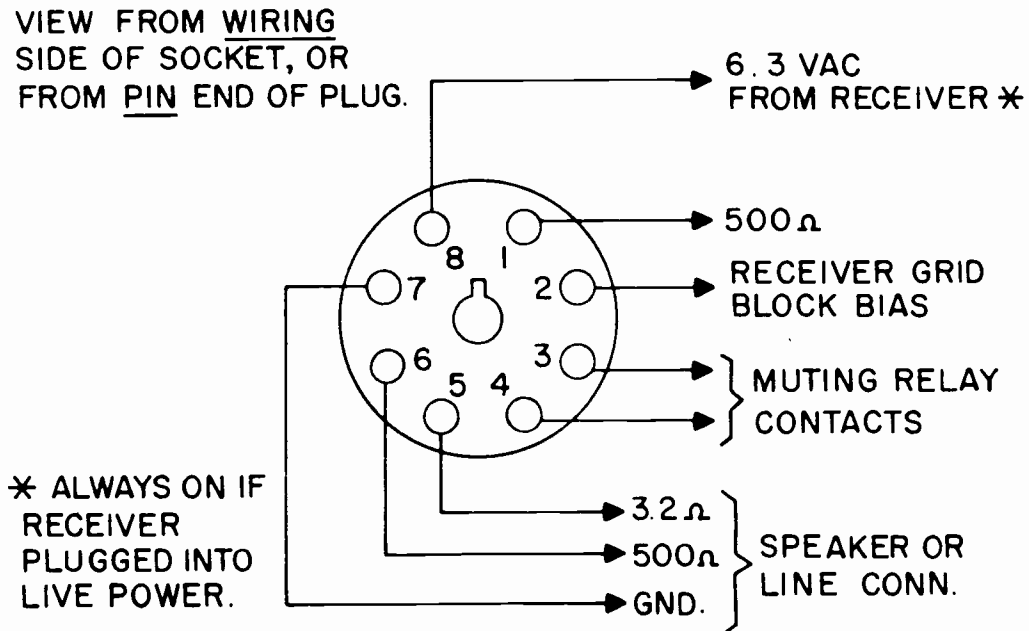

SYSTEM SOCKET CONNECTIONS

"A" SERIES ONLY

HQ-180A OPERATION

With the antenna, speaker and any accessories installed, you are ready to receive transmissions on the amateur bands. These pages are intended to show you the operating methods that will permit the Receiver to give you the best audible signal possible, considering atmospheric and man-made noise. Three most important reminders:

1. Check the listening aids like the noise limiter and slot frequency control -- be sure incorrect setting is not reducing Receiver capability.
2. Always tune the Receiver properly to produce the maximum signal.
3. Don't forget the antenna trimmer -- it requires a different setting on each band. This is because antenna impedance changes with frequency; the trimmer is there to allow for a maximum match at all frequencies.

Plug the Receiver line cord into a 117-volt, 60-cycle line (the export model HQ-180A -E will accommodate 117 or 230 volts, 50 or 60 cycles). Turn the Receiver on, using the RF gain control and the clock timer switch if installed. Check that all tubes are lit. Note that the high-frequency oscillator and mixer tube filaments remain heated at all times, (in the HQ-180A series) if the line cord is left inserted into a source of AC power. Heating of these tubes eliminate drift that occurs in all oscillator circuits as they heat up. Tube life is not reduced through continuous operation. In fact, its life is often extended to many times normal because it is not subjected to the hardships of physical expansion and contraction due to heating and cooling when power is applied and removed. If the receiver is not to be used for extended periods (upwards of 3 days) the line cord should be removed from the power socket. If the oscillator has not been maintained heated, then allow one hour for the Receiver to settle down to a steady tuned condition. Readjust tuning as necessary during this period. Do not attempt to calibrate or set the S-meter until drifting has stopped.

The HQ-180 and "A" Series Receiver is arranged to provide the best reception for AM (voice), for Ccde (modulated or unmodulated CW), and for SSB (single sideband) operation. To be sure of the best results and the clearest reception, read all of the instructions presented here. Set the controls as shown in each illustration for normal operation, and follow the guidelines to improve performance and to tune over the bands. Become familiar with each control and see what each can do for you. Even after you are familiar in every way with the controls, refer occasionally to these instructions to check that you are still getting the most out of the many features of the HQ-180A.

Finally, your particular location and installation will affect operation; experiment with control settings to obtain the best results. And consult with us if there are any problems. The Receiver is for your enjoyment, use it correctly and it will give you years of service.

The Carrier Level S-meter has been adjusted at the factory for correct and calibrated operation, however, two zero adjustments should be checked and reset if necessary; one is mechanical, the other, electrical.

1. With the Receiver turned off, adjust the meter pointer screw on the front face of the meter to set the needle exactly over the zero mark on the scale.
2. Turn on the Receiver; be sure to allow a 1/2 hour warm-up before proceeding further. Set the HQ-180A to "Receive", and set the RF Gain control fully counterclockwise, without actually turning the set off.
3. Now adjust the meter zero control at the rear of the Receiver chassis again for zero on the meter. A small screwdriver inserted through the chassis is required for this setting. Do NOT adjust the meter sensitivity, this requires a special technique and an input signal generator, not normally available for home use. Check carefully with the rear of chassis illustration to be sure of the location of the meter zero adjust.

HOW TO USE THE BAND SPREAD DIAL

The main dial is provided with markers, just below the scales at 4.04, 7.3, 14.425, 21.6 and 29.7 mcs, to establish points for the approximate settings of the main dial when using the band spread scales.

Please remember that we do not claim frequency meter accuracy; also that the high frequency markers, mentioned above, are approximate settings of the main dial to be used in setting up the amateur scales of the band spread dial.

Set the band spread dial at the 100 kcs point at, or nearest to, the high frequency end of the desired amateur band. The main dial should then be carefully adjusted, close to the high frequency band edge marker, to obtain zero beat with the 100 kcs calibrator. Care must be taken that the proper 100 kcs point is employed in order to prevent setting the main dial 100 kcs higher or lower than the amateur band. Next turn the band spread dial to the 100 kcs marker nearest the desired operating frequency. It may be found that this 100 kcs marker is slightly off the exact dial marker. The dial indicator is set to the exact 100 kcs marker, with the small knob to the right of the band spread dial.

If it is desired to use the band spread dial for other, limited frequency ranges than those for which scales are provided, set the band spread dial at the 100 marker of 0 to 100 arbitrary scale and adjust the main dial for zero beat at the highest 100 kcs marker of the desired range. The frequency coverage of the band spread, under this condition, can be determined by counting the 100 kcs intervals covered and by noting the arbitrary scale readings at which they occur, the wanted frequencies can be identified and logged for future use.

GENERAL OPERATING PROCEDURE (ANY MODE)

1. Select mode -- AM, SSB, CW.
2. Set controls for normal operation as shown on the mode illustration -- AVC, RECEIVE, SIDEBANDS, SELECT KCS -- NOISE LIMITER off, SLOT FREQ \pm 5 KCS, BFO centered, VERNIER TUNING zero.
3. Tune in station -- TUNING RANGE, MAIN TUNING, AF and RF GAIN, ANTENNA TRIMMER -- use BAND SPREAD for bandsread, and VERNIER TUNING for single side band intelligibility.
4. Readjust special controls for signal reception improvement, noise or interference elimination, etc. -- NOISE LIMITER, AVC, CALIBRATE, SIDEBANDS, SELECT KCS, BFO, SLOT FREQ.

OPERATION NOTES

AM RECEPTION

1. To obtain maximum fidelity, the widest bandwidth is normally used. However, under conditions of severe interference from spurious signals or atmospheric noise, the bandwidth is reduced to improve intelligibility although some sacrifice of fidelity results. Adjust bandwidth for best reception.
2. The Slot Frequency control provides an extremely sharp adjustable slot or hole in the selectivity curve. It is normally located outside of the passband of the second IF (455kc/s). It is brought into the passband for the purpose of eliminating interference from heterodyne signals on AM and reducing "monkey chatter" on SSB. On CW reception it will materially aid in reducing or eliminating adjacent or co-channel interference.

Whenever the receiver is being tuned for normal reception be sure to first rotate the Slot Frequency control to either minus 5KC or plus 5KC for normal tuning or the center of the passband will be slotted out, producing 2 spot or 2 peak "S" meter readings.

The Slot Depth control (located behind the front panel) is a very gradual vernier adjustment. In view of this, its effect will not be very noticeable unless proper procedure is employed. This procedure is explained in the service section of this manual. As this control is properly adjusted at the factory, the setting should not have to be changed unless changes have taken place in the circuitry due to component aging etc.

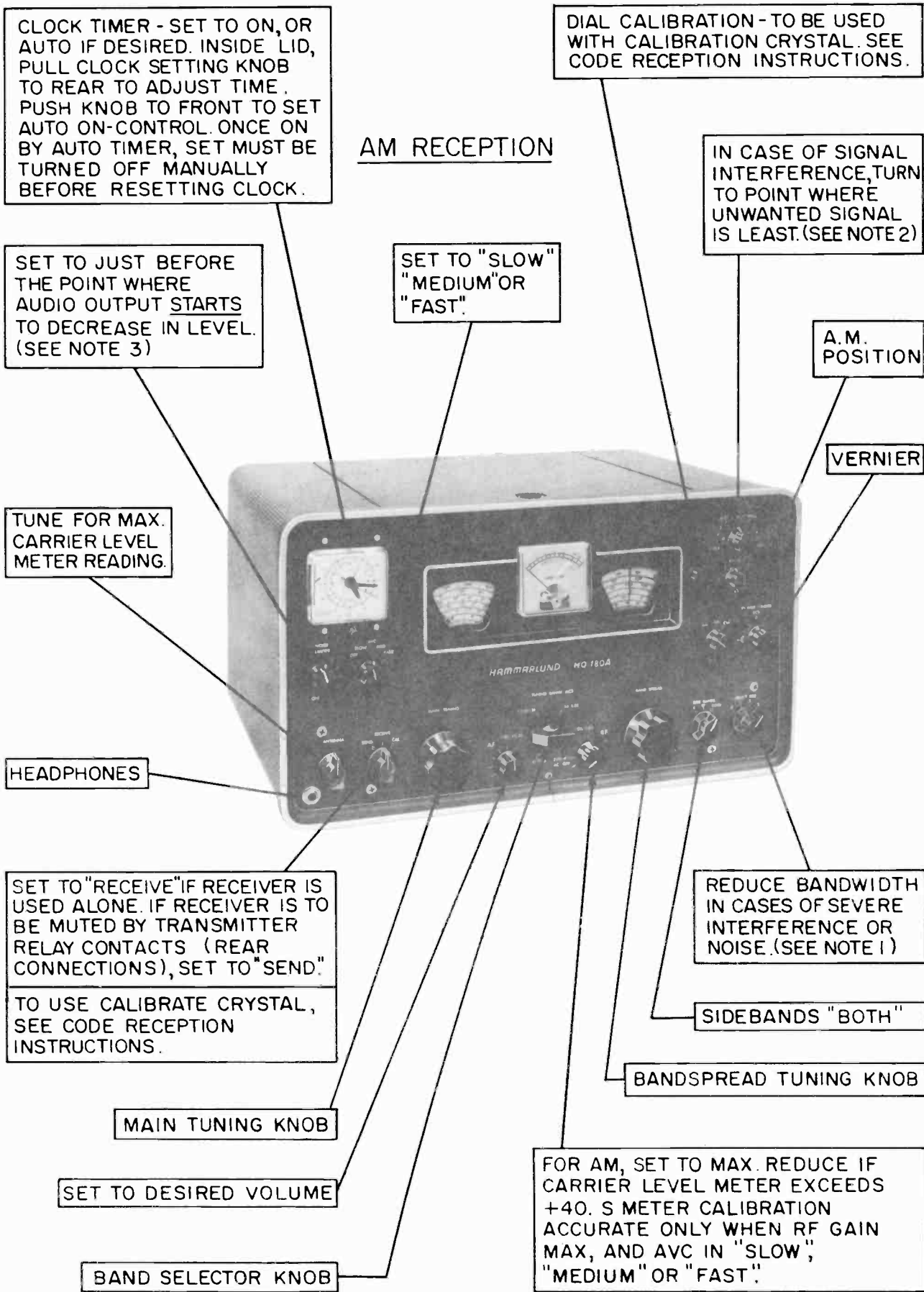

CLOCK TIMER - SET TO ON, OR AUTO IF DESIRED. INSIDE LID, PULL CLOCK SETTING KNOB TO REAR TO ADJUST TIME. PUSH KNOB TO FRONT TO SET AUTO ON-CONTROL. ONCE ON BY AUTO TIMER, SET MUST BE TURNED OFF MANUALLY BEFORE RESETTING CLOCK.

DIAL CALIBRATION - TO BE USED WITH CALIBRATION CRYSTAL. SEE CODE RECEPTION INSTRUCTIONS.

AM RECEPTION

IN CASE OF SIGNAL INTERFERENCE, TURN TO POINT WHERE UNWANTED SIGNAL IS LEAST. (SEE NOTE 2)

SET TO JUST BEFORE THE POINT WHERE AUDIO OUTPUT STARTS TO DECREASE IN LEVEL. (SEE NOTE 3)

SET TO "SLOW" "MEDIUM" OR "FAST".

A.M. POSITION

VERNIER

TUNE FOR MAX. CARRIER LEVEL METER READING.

HEADPHONES

SET TO "RECEIVE" IF RECEIVER IS USED ALONE. IF RECEIVER IS TO BE MUTED BY TRANSMITTER RELAY CONTACTS (REAR CONNECTIONS), SET TO "SEND".

REDUCE BANDWIDTH IN CASES OF SEVERE INTERFERENCE OR NOISE. (SEE NOTE 1)

TO USE CALIBRATE CRYSTAL, SEE CODE RECEPTION INSTRUCTIONS.

SIDEBANDS "BOTH"

BANDSPREAD TUNING KNOB

MAIN TUNING KNOB

FOR AM, SET TO MAX. REDUCE IF CARRIER LEVEL METER EXCEEDS +40. S METER CALIBRATION ACCURATE ONLY WHEN RF GAIN MAX, AND AVC IN "SLOW", "MEDIUM" OR "FAST".

SET TO DESIRED VOLUME

BAND SELECTOR KNOB

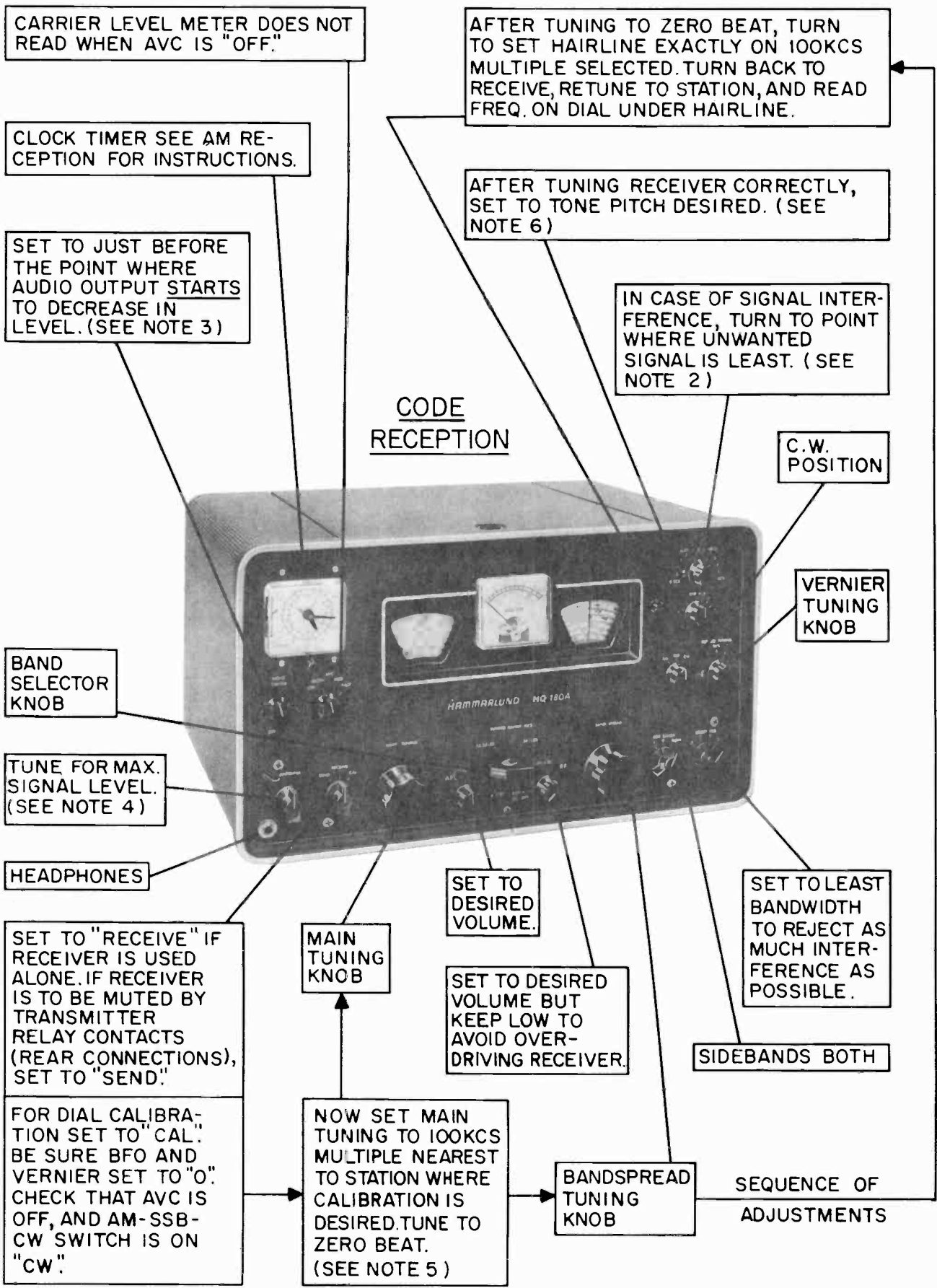

3. The automatic noise limiter can reduce noise to the point where its audio level is electrically no higher than the desired signal level. This point is indicated by the start of audio level decrease as the limiter control is rotated clockwise. The proper setting for this control is therefore at the point just before the audio output of the desired signal is reduced. Further rotation decreases noise and signal equally without improving signal-to-noise ratio.

CODE AND SINGLE SIDEBAND RECEPTION

4. Interrupted continuous-wave (ICW) transmissions do not normally provide steady signals for S-meter readings. However, readings can be made fairly well in CW reception using the "SLOW" AVC position of the AVC switch. In any case tune for the loudest signal level heard.
5. The 100 KCS multiples of the Crystal Calibrator will be found at or near the one decimal numbers only, such as 1.9, 14.3, etc. when the Send/Rec/Cal switch is in the Cal position. (Read "How To Use The Band Spread Dial" in the Operation section of this manual.)
6. For code reception, never set tone by adjusting main tuning, because this detunes the Receiver. Always set BFO to zero first, tune receiver for zero beat, THEN set BFO for desired tone.
7. On SSB, carrier level meter fluctuates with audio. Tune for maximum audio or apparent S-meter level.
8. SSB, (Single Side Band) signals can be identified by the lack of a carrier or beat note ("whistle") when tuning across the signal. A Single Side Band signal NOT properly tuned in will sound scrambled and extremely nasal. Adjust the Main Tuning dial for maximum signal strength (to be judged by ear or S-meter). Adjust the Vernier Tuning for maximum speech intelligibility. (The Vernier Tuning must be tuned slowly for effectiveness) Intelligibility can only be obtained by proper choice of upper (u) or lower (l) sideband reception. The BFO (Beat Frequency Oscillator) control is disconnected in SSB position.
9. The accepted or most popular transmission of single sideband signals insofar as the sideband used will usually be as follows:

75 meters	3.8 to 4 mc	Lower Sideband
40 meters	7.0 to 7.2 mc	Lower Sideband
20 meters	14.200 to 14.350 mc	Upper Sideband
15 meters	21.250 to 21.450 mc	Upper Sideband
10 meters	28.6 to 28.7 mc	Upper Sideband

The use of upper or lower sideband will vary on the other bands covered by this receiver and it is not unusual for the other sideband to be used on the above mentioned bands. If a SSB signal cannot be made intelligible using the vernier tuning control, change to the other sideband switch position.

CLOCK TIMER SEE AM RECEPTION FOR INSTRUCTIONS.

DIAL CALIBRATION- TO BE USED WITH CALIBRATION CRYSTAL, SEE CODE RECEPTION INSTRUCTIONS.

SET TO JUST BEFORE THE POINT WHERE AUDIO OUTPUT STARTS TO DECREASE IN LEVEL. (SEE NOTE 3)

SINGLE
SIDE
BAND
RECEPTION

BFO: SET TO CENTER FOR HQ-180. FREQUENCY DOES NOT VARY IN "A" SERIES.

SET TO "SLOW" OR "MEDIUM".

IN CASE OF SIGNAL INTERFERENCE, TURN TO POINT WHERE UNWANTED SIGNAL IS LEAST. (SEE NOTE 2)

SSB POSITION



BAND SELECTOR KNOB

TUNE FOR MAX. SIGNAL LEVEL. (SEE NOTE 7)

HEADPHONES

VERNIER TUNING ADJUST FOR BEST INTELLIGIBILITY

SET TO "RECEIVE" IF RECEIVER IS USED ALONE. IF RECEIVER IS TO BE MUTED BY TRANSMITTER RELAY CONTACTS (REAR CONNECTIONS), SET TO "SEND".

SET TO DESIRED VOLUME.

MAINTAIN 2 OR 3KCS BANDWIDTH TO ASSURE INTELLIGIBILITY

TO USE CALIBRATE CRYSTAL, SEE CODE RECEPTION INSTRUCTIONS.

FOR SSB, SET TO MAX. OR AS DESIRED.

SET TO "U" (UPPER) OR "L" (LOWER) DEPENDING ON SIDEBAND USED. SELECTION RESULTS FROM EXPERIENCE AND METHOD OF SSB OPERATION ON PARTICULAR BAND.

MAIN TUNING - SET FOR LOUDEST SIGNAL, IGNORE INTELLIGIBILITY. (SEE NOTE 8)

SEQUENCE OF TUNING

BANDSPREAD TUNING

HQ-180A MAINTENANCE

This Receiver has been carefully constructed, inspected, adjusted and aligned at the factory to provide a long period of trouble-free use. Unless you have the proper equipment and the detailed knowledge to service complex electronic circuitry, it is not recommended that any other maintenance but tube testing be attempted. In particular, DO NOT ADJUST TRIMMERS OR TRANSFORMER CORES, because this will reduce the reception capabilities, unless it is done while following the alignment instructions correctly.

HQ-180A CIRCUIT DESCRIPTION

Many Receiver troubles can frequently be resolved simply by testing and changing tubes and by making a few minor adjustments, but in order to properly service this set it is important to be able to diagnose obscure troubles through an understanding of the circuits involved. It is for this purpose that this section is provided. A communications receiver of this type contains several special circuits not normally included in the home radio. Examples of such circuits are the BFO (beat frequency oscillator), the slot, triple conversion, delayed AVC (automatic volume control), etc.

The complete circuitry of the HQ-180 and "A" Series, is shown in the schematic diagrams included at the end of this book. To help in understanding these diagrams, a block version is presented on the next page. While reading the test, follow both the block and schematic diagrams -- one will illustrate the overall system, while the other will provide all of the connection details.

The "X" series of receivers provides an eleven position fixed frequency crystal oscillator assembly which is factory installed in the panel space provided for the 24 hour clock timer. The knob allows selection of normal variable frequency tuning or any one of eleven fixed frequencies crystal controlled. Six crystals are mounted on the front plate of the oscillator assembly and may be changed quite readily to shift frequencies. The remaining five crystals are mounted behind the front panel on the oscillator box and may be changed by lifting the top cover of the cabinet. It is intended that the five inside crystals will be for commonly used channels not subject to being changed very often. The receiver can be zeroed into the channel frequency by manipulating the vernier tuning control on the front panel. This will correct for frequency discrepancy due to crystal tolerance and assure accurate "netting".

The use of the crystal controlled oscillator will permit the highly stable reception of signals on the eleven channels selected. The only operation required besides turning the selector switch to the desired crystal position is to turn the band switch to the desired crystal position and tune the main dial to the approximate frequency rocking the knob for maximum "S" meter indication.

In order to ensure proper operation, the crystals should be ordered from your local authorized Hammarlund distributor.

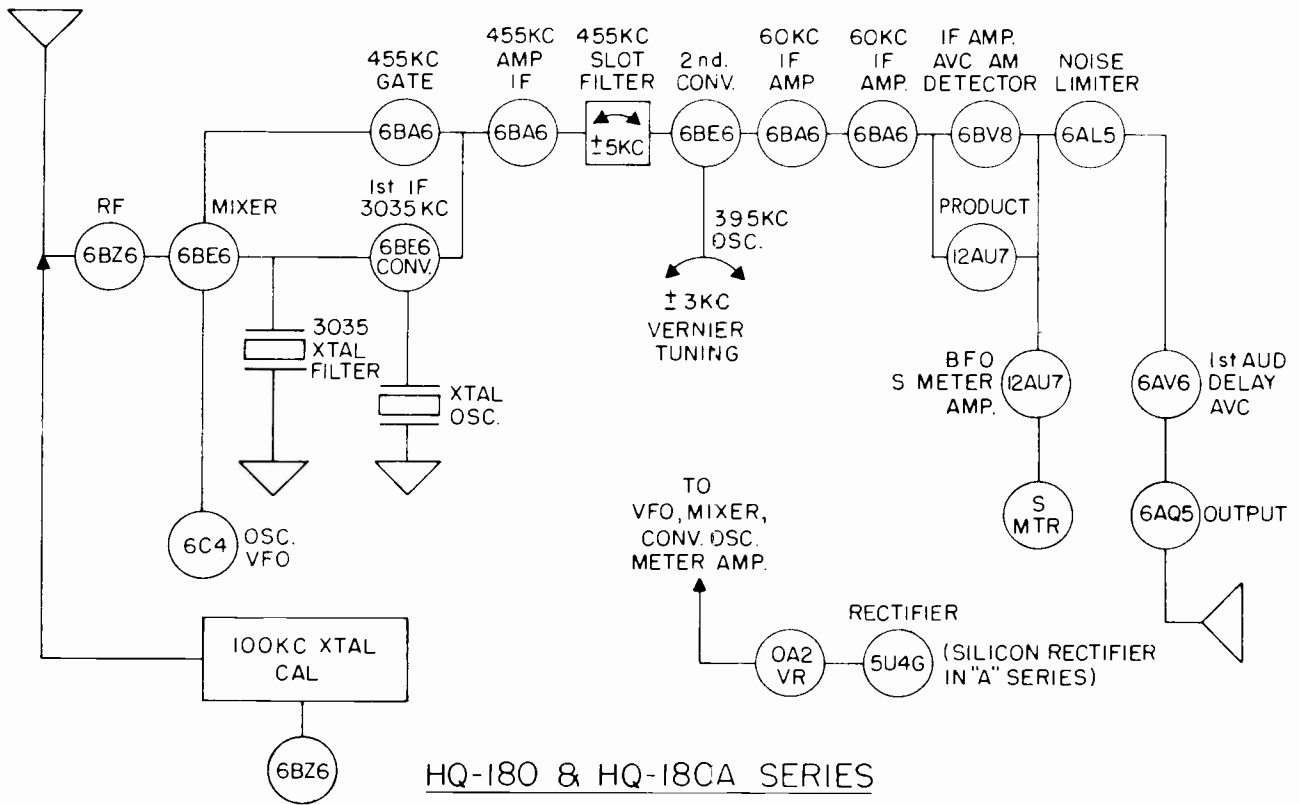

HQ-180 & HQ-18CA SERIES
RECEIVERS

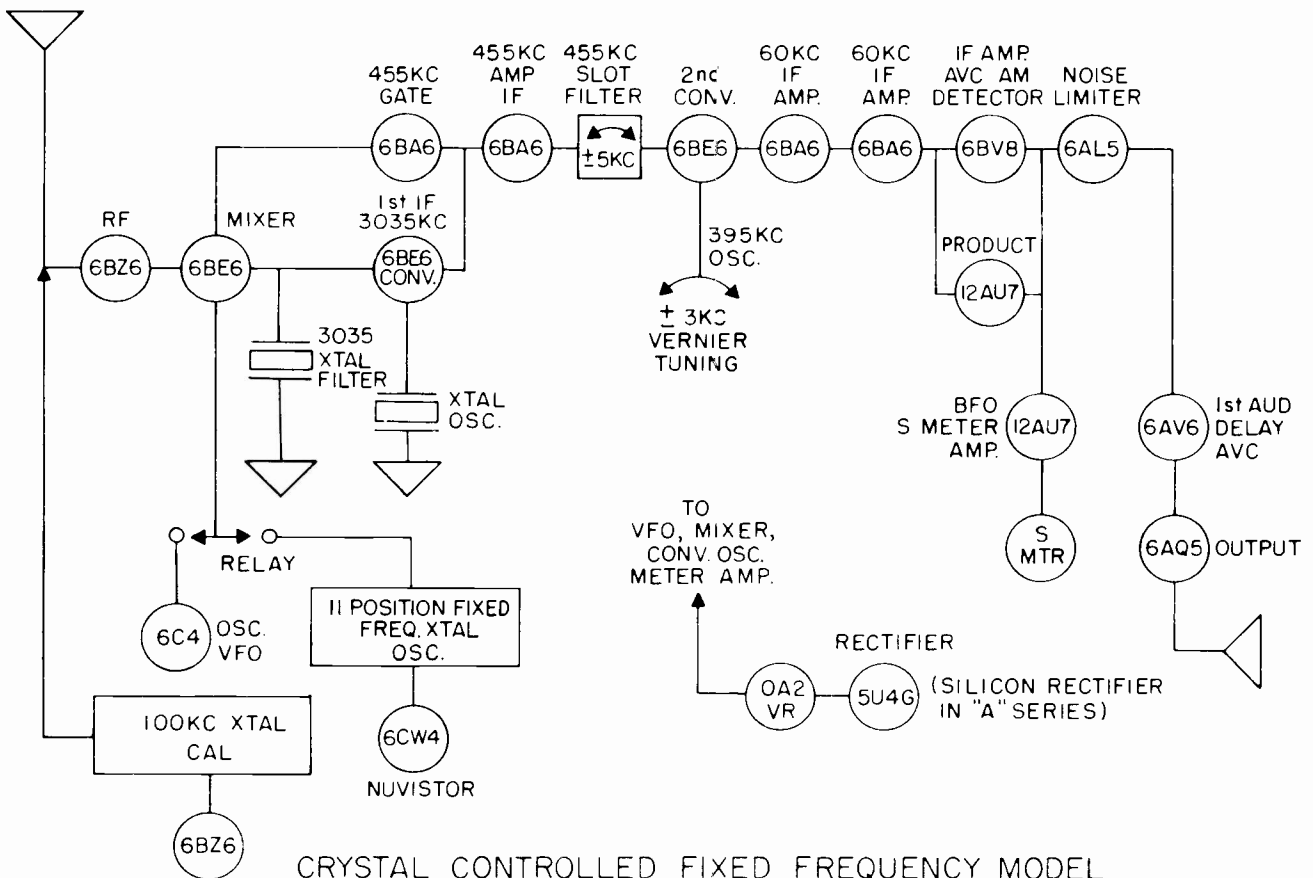

CRYSTAL CONTROLLED FIXED FREQUENCY MODEL
HQ-180XE & HQ-180AX

The oscillator or actual crystal frequency for a given signal frequency shall be determined from the following:

<u>SIGNAL FREQUENCY RANGE mc</u>	<u>ADD IF----- FREQUENCY mc</u>	<u>SUBTRACT IF- FREQUENCY mc</u>	<u>MODE OF OPERATION</u>
.54 to 1.05 mc	.455000		Fundamental
1.05 to 2.05 mc	.455000		Fundamental
2.05 to 4. mc	.455000		Fundamental
4.0 to 7.85 mc	.455000		Fundamental
7.85 to 15.35 mc	3.035		Fundamental
15.35 to 20.662 mc	3.035		Fundamental
20.662 to 30.000 mc		3.035	2nd Harmonic

NOTE: WHERE LOW SIDE INJECTION IS SPECIFIED, HIGH SIDE INJECTION MAY BE USED AT REDUCED SENSITIVITY.

The RF signal is received at the antenna and applied to the RF amplifier through the antenna terminal strip or shielded connectors, and through the band-switched antenna tuned circuit. The antenna trimmer, compensating for differing antenna characteristics at differing frequencies, is located across the secondary of the antenna transformer. The calibration oscillator, turned on in the calibrate position, applies its signal to the RF amplifier. This oscillator is a crystal controlled type at 100 KCS, developing a very large number of 100 KCS harmonics to cover all of the bands in the Receiver.

To control the Receiver sensitivity, one section of the RF gain control sets the bias of the RF amplifier stage. Rotating the control clockwise decreases tube bias, permitting increased amplification and thereby increasing sensitivity to weaker signals.

From the RF amplifier the signal is applied to the first mixer where it is heterodyned with the output of a separate high frequency oscillator. The resulting frequency is the first intermediate frequency (IF). From .54 to 7.85 mc/s the HF oscillator is located 455 kc/s above the signal frequency. From 7.85 to 30 mc/s the HF oscillator is 3035 kc/s above the signal frequency. When operating the 7.85 to 30 mc/s bands, the difference frequency of 3035 kc/s is fed through a crystal filter and is heterodyned with 2580 kc/s crystal controlled oscillator in the converter tube to produce 455 kc/s 2nd IF. When the Band Selector switch indicates .54 to 7.85 mc/s the converter tube ceases to function and the gate tube becomes a regular 455 kc/s amplifier. Band switching and frequency tuning occurs in the grids of the mixer and of the oscillator. The arrangement of heterodyning used in this Receiver is listed in the accompanying chart. The stability of the oscillator circuit, a must for accurate and repeatable tuning, is maintained by using a separate tube, and keeping the heater supply on at all times, minimizing drift tendencies. In the "A" series only, the filament is supplied with power through filament transformer T30 as long as the line cord is connected to a source of power. If the clock is mounted, power will be required at all times.

The chart of the heterodyning system shows that the second mixer becomes a 455 KCS amplifier on the two lowest frequency bands. Section S2F of the band switch accomplishes this by removing the crystal circuit from the oscillator portion of the tube at this time. When the oscillator is allowed to work, the first IF signal beats with the oscillator signal to become the second IF.

V4 is a 455 KCS amplifier whose gain is also controlled by a second section of the RF gain control, resulting in receiver sensitivity adjustment in the same manner as before.

Before the 455 KCS signal is applied to the third mixer, it is passed through the slot circuit. This circuit is designed to provide a narrow section of frequency rejection capable of being set precisely on an interfering signal. The slot depth control permits its depth or amount of rejection to be set as required for best results. The diagrams show the characteristics and the capabilities of this circuit.

<u>BAND</u>		<u>Frequencies in KCS</u>					
<u>MCS</u>	<u>RF</u>	<u>1st OSC</u>	<u>1st IF</u>	<u>2nd OSC</u>	<u>2nd IF</u>	<u>3rd OSC</u>	<u>3rd IF</u>
.54 - 1.05	S	S \neq 455	455	(Amplifier Stage)		395	60
1.05 - 2.05	S	S \neq 455	455	(Amplifier Stage)		395	60
2.05 - 4.0	S	S \neq 455	455	(Amplifier Stage)		395	60
4.0 - 7.85	S	S \neq 455	455	(Amplifier Stage)		395	60
7.85 - 15.35	S	S \neq 3035	3035	2580	455	395	60
15.35 - 30.0	S	S \neq 3035	3035	2580	455	395	60

S = Signal Frequency Received

CHART OF FREQUENCY HETERODYNING

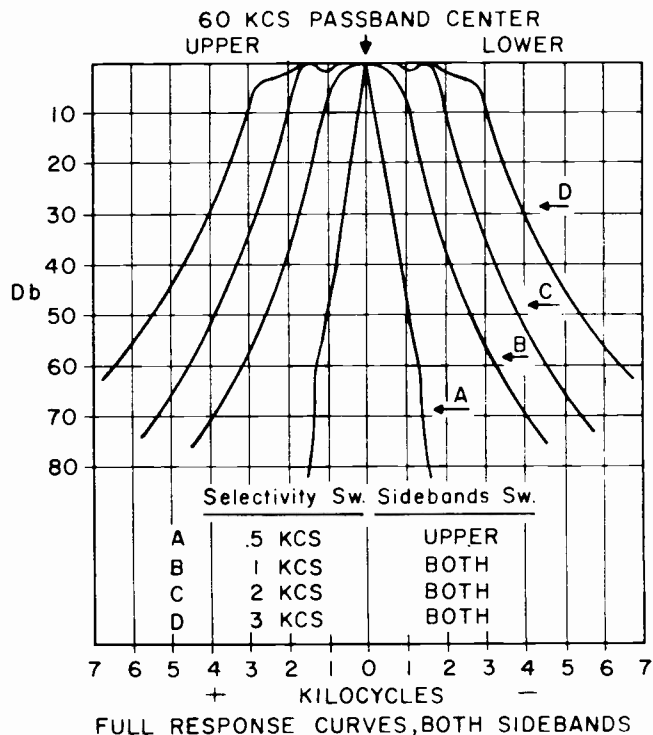
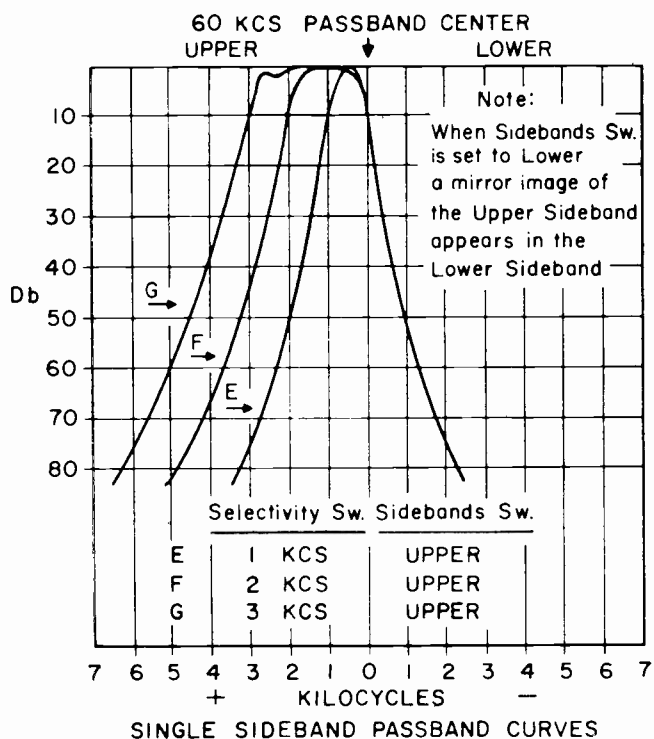
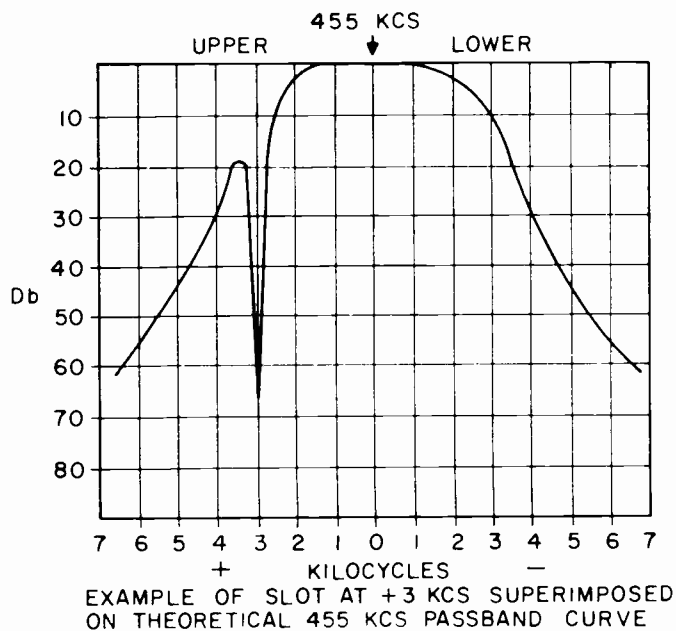
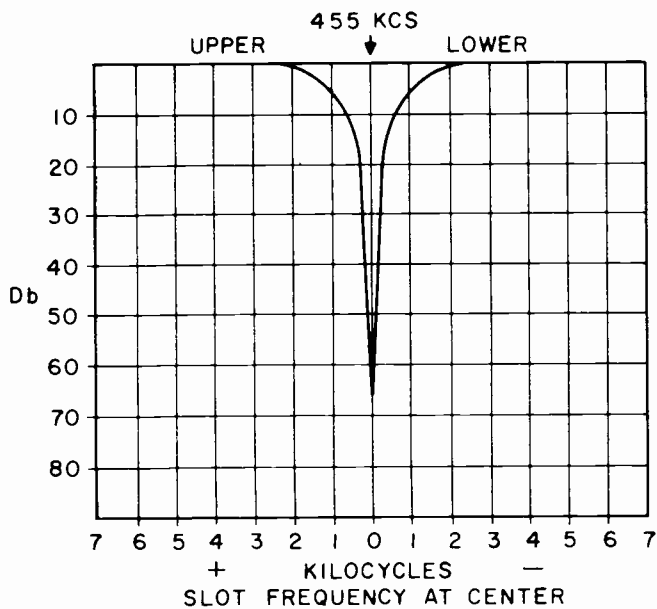

Conversion again occurs to result in a third IF of 60 KCS. Three stages of 60 KCS IF amplification are provided along with means for adjusting the selectivity of the receiver to aid in the rejection of unwanted interfering signals. This is especially useful for code reception where little sidebands are transmitted. A wide band receiver is a detriment here because of such a receiver's capability of amplifying all nearby stations almost as well as the one to be listened to. For single sideband operation, a second switch permits setting the receiver passband for maximum reception only on the side of the carrier required for reception.

The signal delivered from the 60 KCS amplifier stages is then applied to four separate detector circuits, two for efficient audio development, and two for the generation of correct AVC voltages that will assure the best possible reception of all types and levels of RF signals. The general block diagram shows that AM reception is handled by a normal diode detector circuit. See the simplified schematic of the detector, BFO and noise limiter circuits. In the AM position, the resulting audio is passed through the noise limiter tube V10 and on to the audio gain control.

In the CW position, V9 acts as a product detector, and the audio is developed from the beat between the incoming 60 KCS and the output of the BFO at a frequency that is at or near 60 KCS depending on the setting of the BFO control. The BFO is aligned so that zero beat occurs when the BFO control is centered. The audio output is then taken from the junction of R73 and R74 and applied through the CW position of the mode switch to V10 in the same manner as for the AM audio.

Single sideband detection is exactly the same as for CW except that the BFO is a fixed frequency in the "A" series. For the HQ-180 series, keep BFO control at "0". In SSB operation tuning for intelligibility requires that the suppressed carrier be replaced within the receiver. The BFO does just that, the vernier tuning dial being used to precisely tune the receiver to the sideband that has been transmitted. The heterodyning between the BFO frequency and the received sideband produces audio in the same manner as audio is produced for CW.

The noise limiter is a very useful circuit that is designed to assure that no noise or interference signal peaks will be higher than the wanted signal. In the "OFF" position, B \nearrow is applied to the plates of V10, while the cathodes are grounded. Since the tube sections are conducting, any signal applied to V10 from the detectors is passed through to the audio gain control. In the "ON" position, the plates are connected to ground, while B \nearrow is applied to the cathodes through the noise limiter control. The circuit is arranged that when the control is at its counterclockwise end of rotation, audio is permitted to pass through almost unreduced. As the control is turned clockwise, the B \nearrow applied to the cathodes increases so that strong peaks are clipped. In operation, it will be noted that the noise limiter is used to clip noise peaks that are higher than the desired audio; the control is therefore turned clockwise until it is noted that the wanted audio starts to be clipped (volume reduced). The correct position of the control is just below the point where this occurs. At this point, maximum clipping is occurring without reducing the wanted signal. The noise limiter is capable of operation on any type of signal, but it should be noted that less noise and interference can often be obtained by reducing the receiver bandwidth as well.

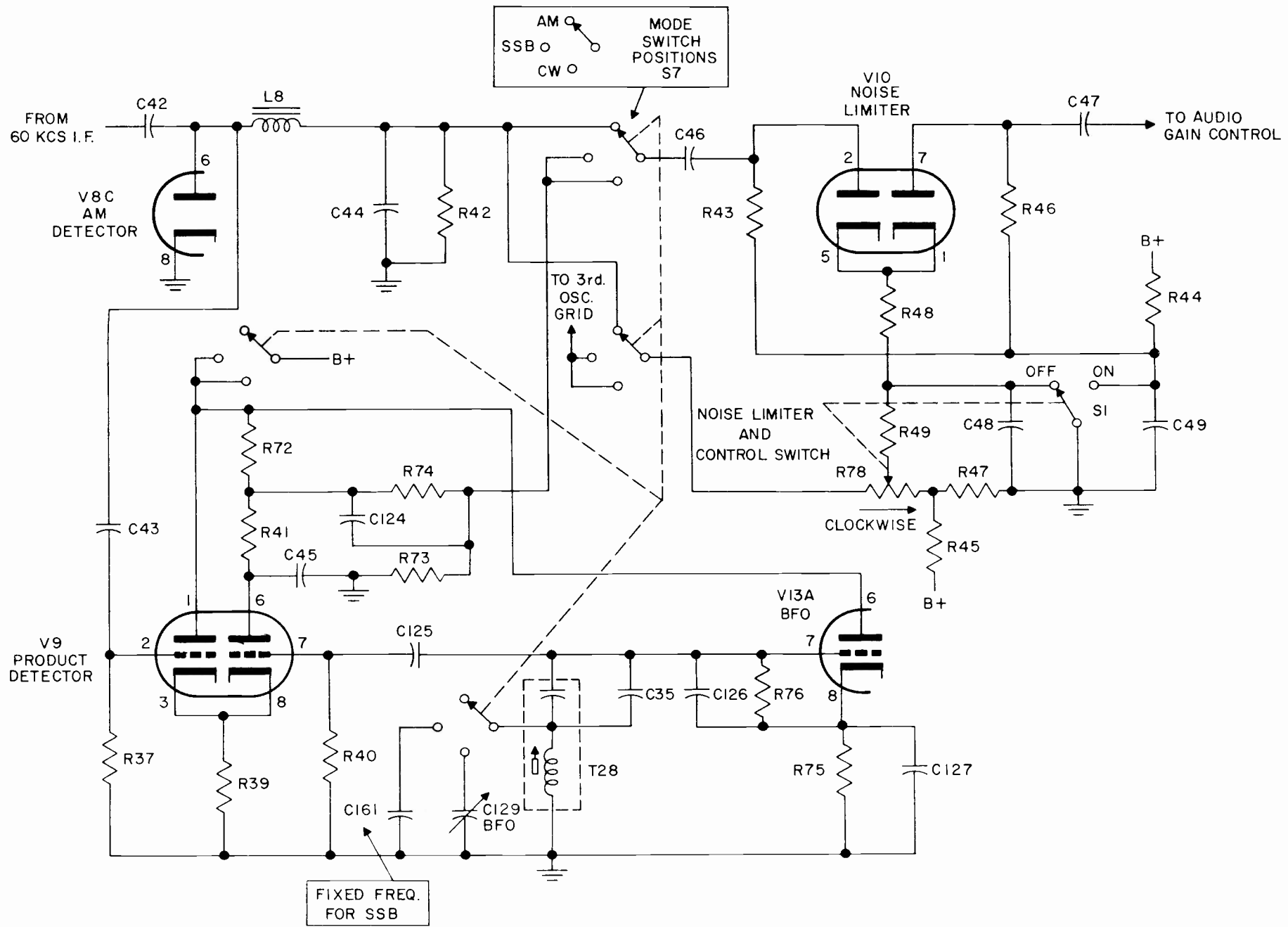

DETECTOR, BFO & NOISE LIMITER CIRCUITS

Automatic volume control voltages are developed from the two circuits illustrated. RF detection takes place through both V8B and the diode section of V16. Each circuit is arranged to reduce a negative voltage that will increase as the received signal increases. Except in the "OFF" position, AVC voltages are applied to the RF amplifier, to the 2nd IF amplifier, to the 3rd mixer, and to the 1st 60 KCS IF amplifier. The positive voltage developed across R92 prevents AVC from being applied to the RF amplifier until the incoming signal is high enough to overcome it. This delayed AVC improves the reception of weak signals.

The other AVC circuit is not biased in this fashion, but it is designed to allow for an adjustable decay characteristic. AVC is applied immediately, but its decay in the event of fading is adjustable to be slow, medium or fast depending on the type of signal and on the atmospheric conditions of the time. R83, R84 and R85 set the discharge time of C131, creating the appropriate AVC decay.

The carrier level "S" meter circuit operates on the same AVC signal just described. The circuit is a bridge, with the tube and R88 on one side, and R21, R20 and R22 with its switched resistors on the other. The meter is in the center of the bridge, set to zero in the absence of a signal (AVC zero). When a signal is received, AVC is developed, the tube current changes to unbalance the bridge, and the meter reads. The greater the signal, the greater the unbalance, and the higher the meter reading. The sensitivity setting is made only when a signal of known strength is applied to the receiver, usually from a precise signal generator whose output level can accurately be measured.

The audio stages are conventional in nature, except for the special auto-response circuit illustrated. This is a negative feedback system that provides maximum effect at low audio gain control settings. Strong signals are then permitted the highest fidelity of response and lowest distortion, while increasing the gain on weak signals narrows the audio response to improve signal selectivity. An improved signal-to-noise ratio results. A further advantage is the critical damping of the speaker for elimination of speaker resonance effects. Speech reception is improved and receiver output noise is reduced.

The receiver power supply is arranged to permit the 1st oscillator and mixer to remain heated even when the rest of the set is turned off (in the "A" series only). As has been previously mentioned, this to provide increased receiver stability. The schematic diagram shows these tubes heated from a separate filament transformer, connected to the power line through only the fuse. The electric clock timer is also connected to the line in the same manner. The timer switch mechanism is in series with the normal on-off switch so that the set can be turned on automatically at any desired time. The timer mechanism is designed that it must be turned off manually to reset the mechanism for automatic turn-on in the next 24-hour period.

Plate voltage regulation is enhanced through the use of silicon rectifiers (in the "A" series only), and further stability is established with a gas regulator tube for the critical RF stages and for the calibrated "S" meter.

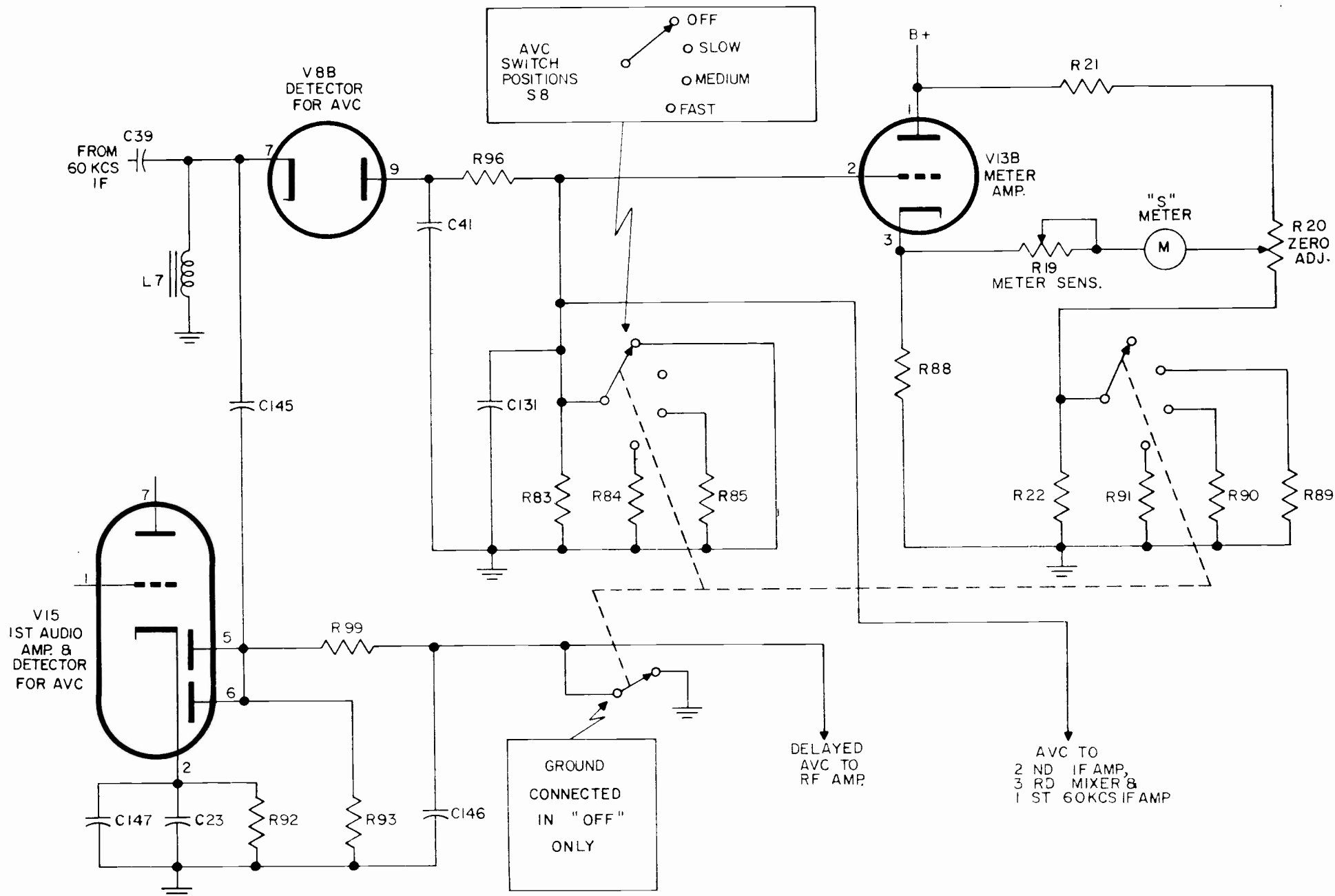

AVC & "S" METER CIRCUITS

Except for the power transformer primary connections, the supply circuitry for the export version is the same.

Finally, there are the accessory and system sockets, and the send-receive switch, each clearly illustrated on the schematic diagram and self-explanatory. In the send position, the B to the RF amplifier, the 2nd mixer and the 2nd IF amplifier is removed, muting the receiver. Further or alternate muting can be applied through the system socket from the transmitter (in the "A" series only).

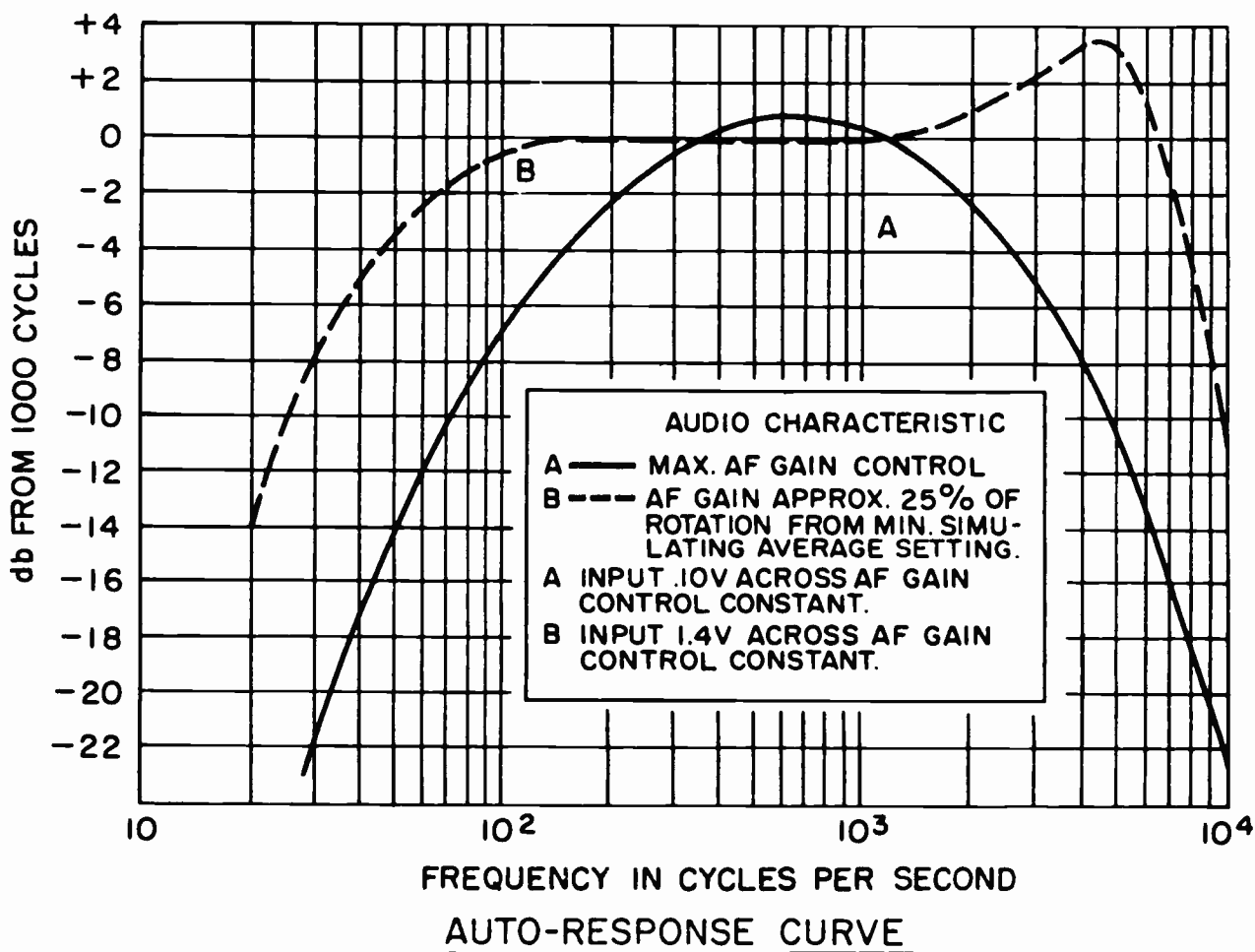

AUTO-RESPONSE
FEEDBACK
LOOP

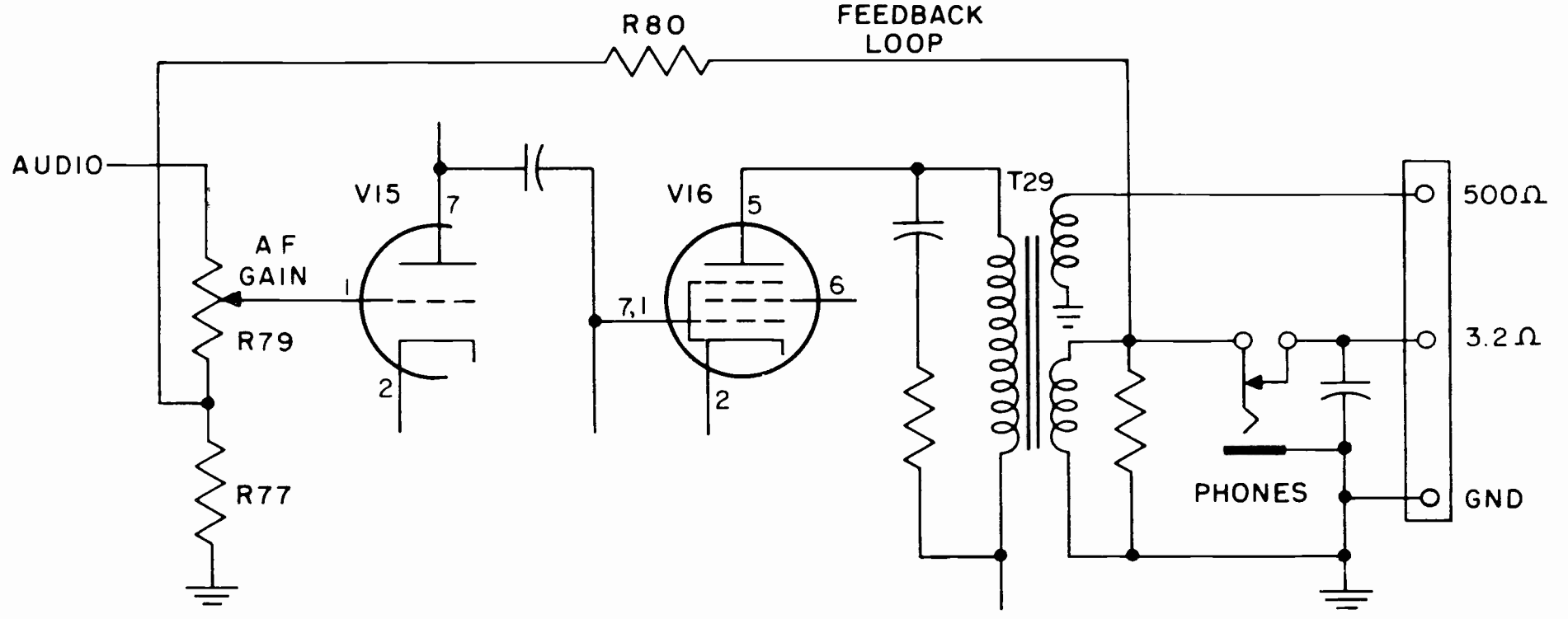

AUTO-RESPONSE CIRCUIT

HQ-180A SERVICE AND MAINTENANCE

This section will provide the instructions for the correct servicing of the Receiver. While no particularly unusual procedures are called for, it should be noted that proper tools and test equipment must be available to undertake the electrical alignment. Inadequate or inaccurate test equipment may result in generally poor operating results.

Excessive oscillator drift which is most noticeable on all of the high frequency bands plus a microphonic condition, is usually the result of a poor 6C4 (V12) high frequency oscillator. This tube is also capable of producing a poor beat note with a ripple in it, also especially noticeable on the high bands. Excessive drift can also be attributed to a poor 6BE6 (V2). This tube can also cause hum modulation most evident on the two highest frequency bands. Sometimes interchanging the 6BE6s between V2 and V3 can produce a noticeable improvement.

Normally there is no reason to remove the chassis from the cabinet, because the top cover allows access to all of the tubes, and to the clock adjustment. However, in the case of RF and IF alignment, it will be necessary to take the chassis out to gain access to the under-chassis alignment settings.

Further disassembly is not recommended except in the case of dial cord replacement. As this is a steel cable, breakage is unlikely, but if it should, it will be required to remove the front panel from the chassis, and to remove the two calibrated dials.

The instructions for the removal of the chassis from the cabinet, and for the disassembly of the front panel, are presented here. Follow the instruction steps with care, and there will be no trouble identifying and replacing all of the parts. Note particularly the knob and dial alignment procedures.

Removing Receiver Chassis from the Cabinet

1. Disconnect all wires and cables at the rear of the chassis.
2. Tip the cabinet up from the front and remove the hex head screw on the bottom.
3. Remove the three hex head screws at the back of the cabinet.
4. Loosen the two Phillips head screws at the top front of the cabinet; do not remove them.
5. Slide the panel and chassis forward to clear the cabinet. Guide the line cord as necessary. It is advisable to set the chassis down so that the panel overhangs the edge of a table. This will protect the panel finish, and relieve strain on the panel mounting screws.

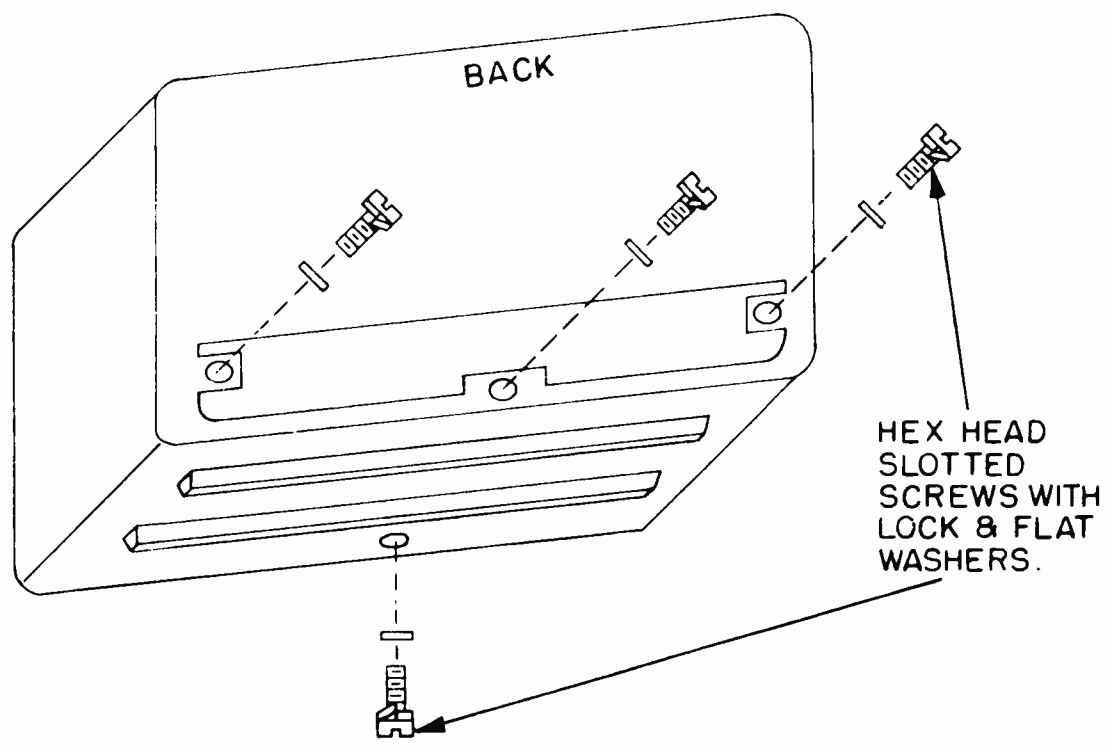
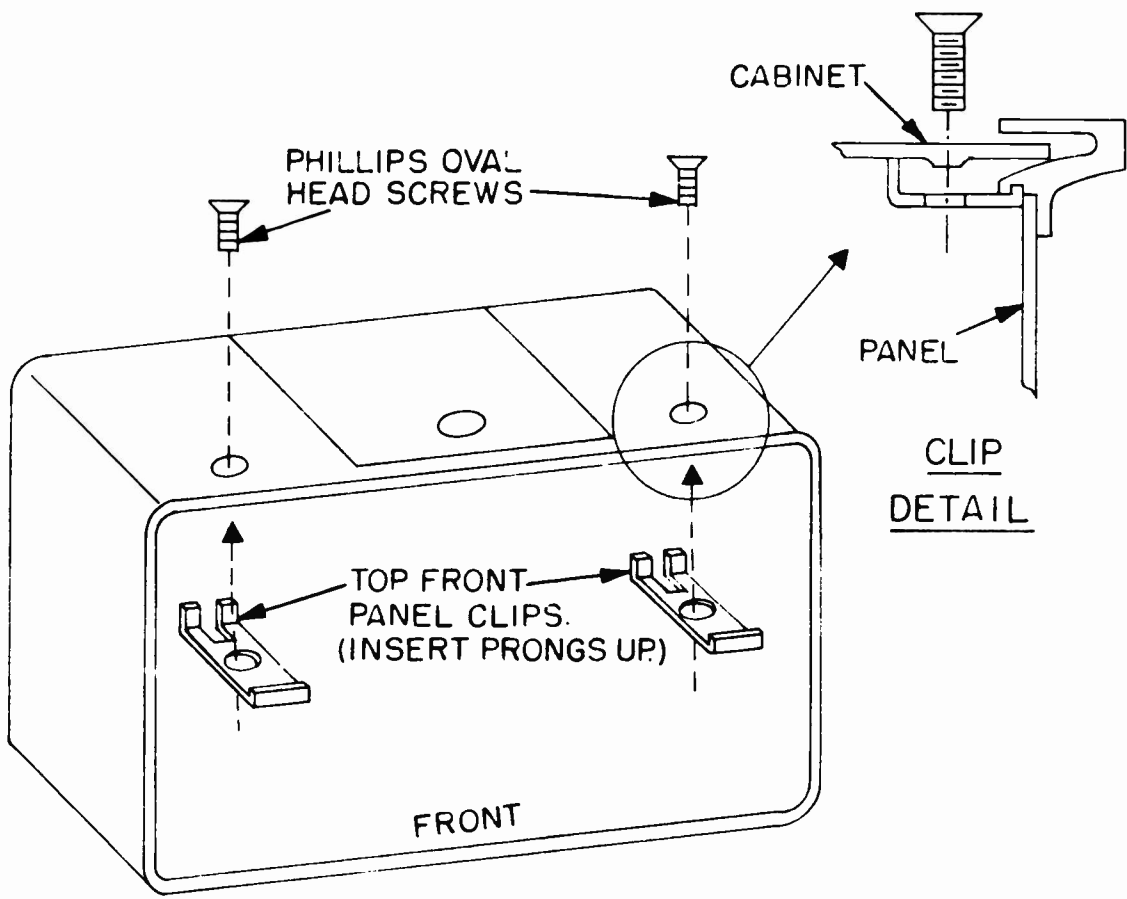

HARDWARE TO FASTEN CHASSIS TO CABINET

Replacing Receiver Chassis in the Cabinet

1. Slide the chassis and panel into the cabinet, guiding the line cord through the rear opening as necessary. Check that the "L" bracket under the chassis does not catch under the cabinet as the chassis is slid into it. Make sure the cabinet edges are fitted into the slot around the inside edge of the panel. Check that the clips fit under the panel edge as shown in the illustration.
2. Insert the three screws, lock and flat washers in the back of the cabinet. Do not tighten firmly yet.
3. Tip up the cabinet and insert the screw, lock and flat washer in the bottom front of the cabinet. Do not tighten yet.
4. Tighten the three screws in the rear first, then tighten the screw on the bottom.
5. Tighten the two Phillips head screws in the top of the cabinet.

Removal of the Front Panel from the Chassis

Refer to the diagrams for the locations and identification of all parts.

Step 1. Remove all knobs except those of the clock and dial calibration. Turn all capacitors so that their plates are fully meshed.

Step 2. Remove the following:

Nuts from the controls shown on the diagram.
Nut and lock washer from the headphone jack.
Screws and lock washers from the capacitors.
Pry off the two red pointers; be careful not to bend them.

Step 3. On the back of the front panel, remove the following:

Large nuts and fiber washers.
Dial calibration drive discs.
"S" meter lamp assembly.

Unsolder the two wires to the meter, and the three wires on the clock.

Pull off the other two lamp assemblies for working convenience in later steps.

Step 4. On the front of the panel, remove:

Four Phillips screws and nuts.
One smaller Phillips screw and "L" bracket. Hold panel to prevent it from falling as the last screw is removed.

This completes the removal of the front panel.

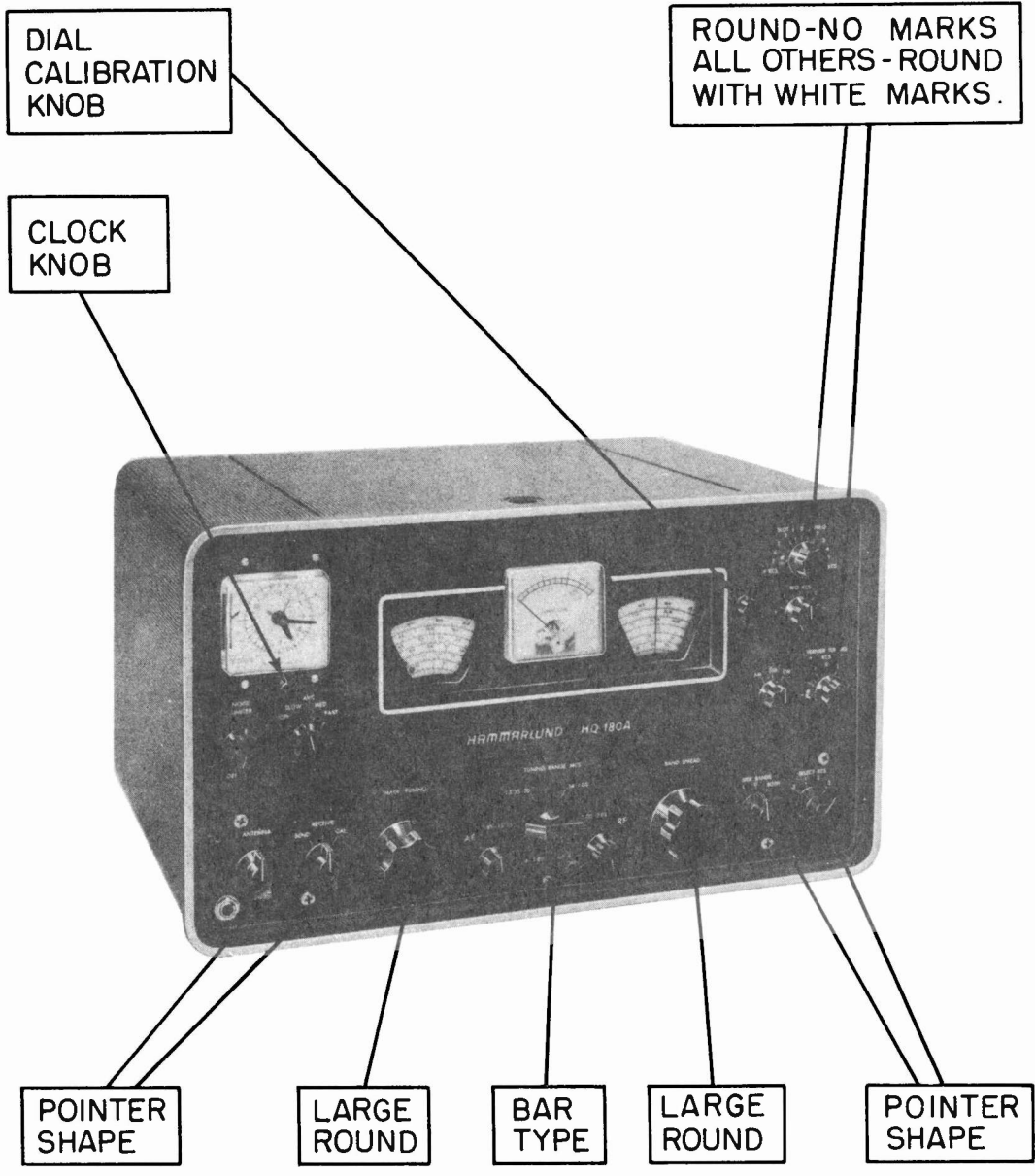

REMOVE ALL KNOBS EXCEPT CLOCK AND DIAL CALIBRATION

STEP 1

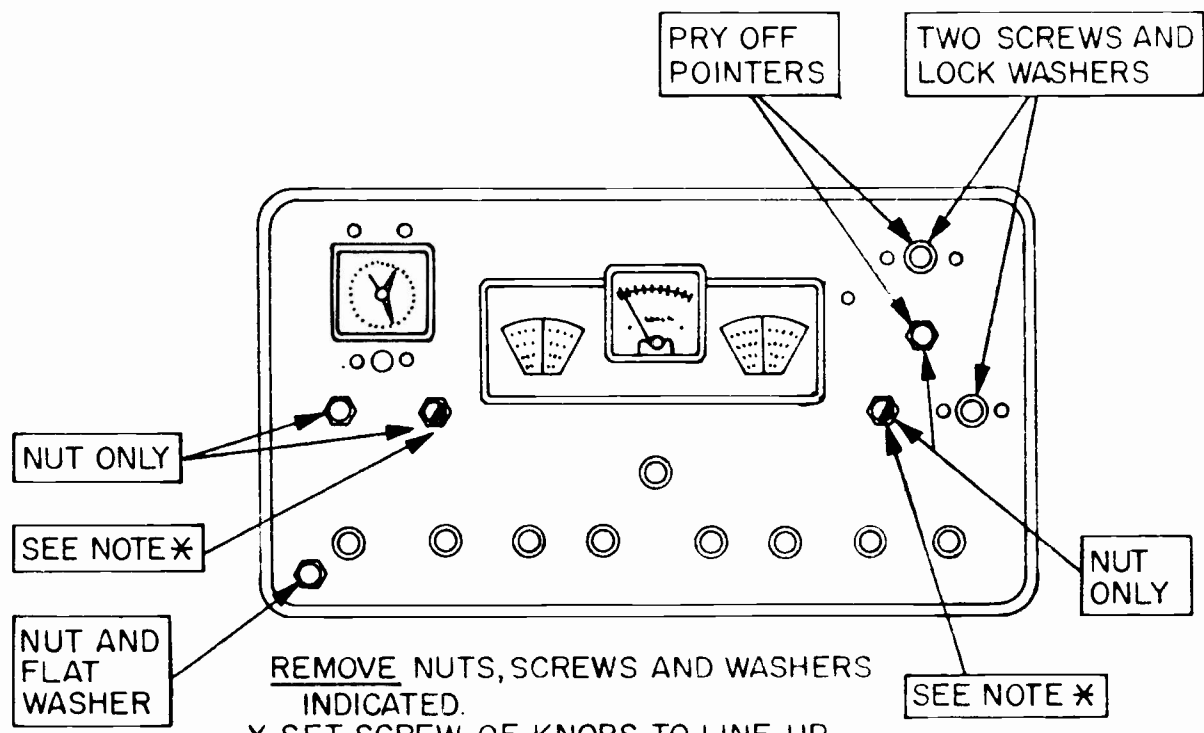

REMOVE NUTS, SCREWS AND WASHERS INDICATED.

* SET SCREW OF KNOBS TO LINE UP WITH FLATS OF SHAFTS.

CAUTION TO PREVENT DAMAGE TO CAPACITOR PLATES, MAKE SURE THEY ARE FULLY MESHED.

STEP 2

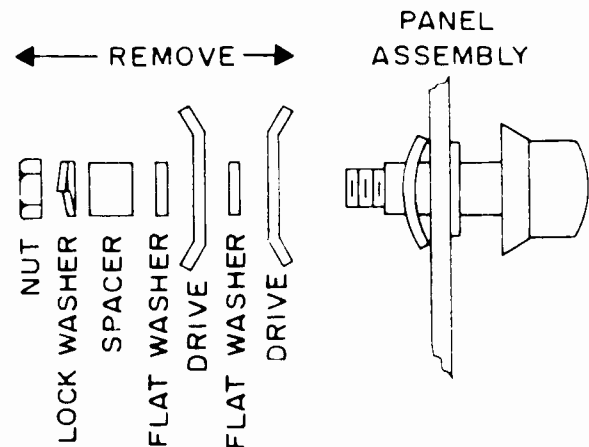

DETAIL OF DIAL CALIBRATION DRIVE

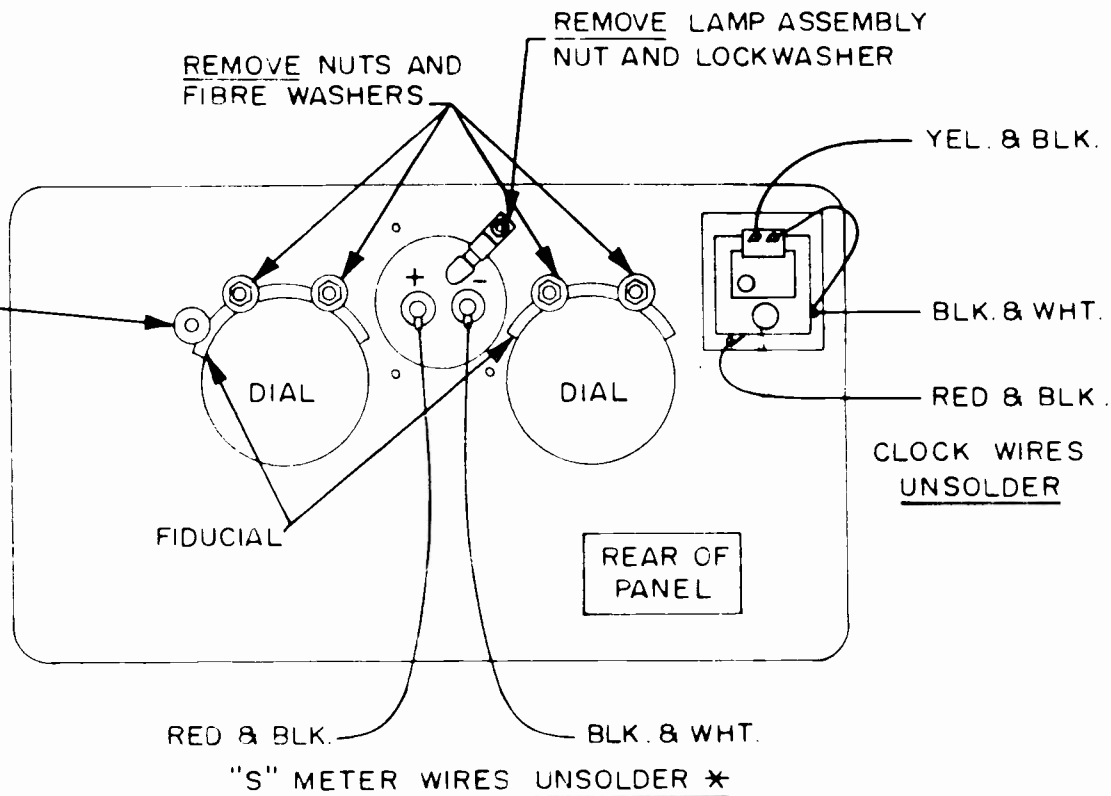

REMOVE AND UNSOLDER AS INDICATED - FOR CONVENIENCE, - PULL OFF OTHER TWO LAMP HOLDERS.

* DO NOT REMOVE NUTS FROM METER, THESE ARE INTERNAL MOUNTING STUDS.

STEP 3



PHILLIPS
SCREW AND
NUT WITH
CAPTIVE
LOCKWASHER.

PHILLIPS
SCREW AND
NUT WITH
CAPTIVE
LOCKWASHER.

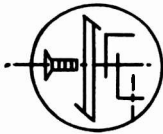

PHILLIPS
SCREW AND
"L" BRACKET.

REMOVE SCREWS, NUTS AND BRACKET INDICATED

CAUTION - HOLD PANEL TO PREVENT FALLING

STEP 4

Step 5. Loosen but do not remove the set screws on the two dials. DO NOT MOVE THE SET SCREWS OF THE PULLEYS. Now pull the two dial assemblies forward, at the same time guiding the left dial out of the tuning drive discs.

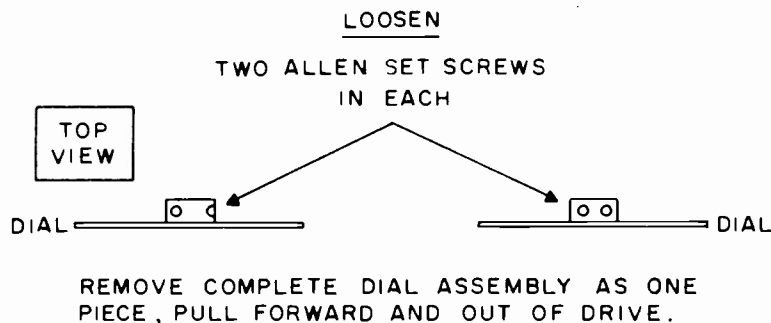

STEP 5.

Step 6. Replace the two dial assemblies on their shafts, inserting the left dial into the tuning drive discs. Make sure that the tuning capacitor plates are fully meshed, then turn the dials so that the left end of each dial is approximately vertical.

Push on the dials so that the shaft ends are about 1/8 inch recessed. It should be possible to see the previous set screw marks on the shafts to help in this setting.

Now tighten one set screw on each shaft. Final setting will come in a later step.

Step 7. Check that the proper nuts and lock washers are in place on the controls that were removed from the front panel.

Locate the panel in place, inserting the controls in their proper holes.

Secure the front panel by replacing the hardware removed in Step 4.

Note that the "L" bracket fits over the small terminal strip located inside the chassis.

Step 8. On the back of the front panel, replace the hardware removed in Step 3. Check that the dial calibration drive is correctly restored with the transparent segment within the discs. Resolder the wires to the meter and to the clock; see the Step 3 illustration for the wire color code.

Step 9. On the front of the panel, replace the hardware removed in Step 2. Be careful not to scratch the panel when tightening the nuts, and remember to line up the flats of the two controls indicated in the Step 2 illustration.

After Step 9 is completed, check that the dials and the dial calibration system operate smoothly and without interference. If necessary, loosen the front panel screws of Step 4 and readjust panel positioning to obtain proper dial operation.

Step 10. Replace the two red pointers by pushing them onto the inner shafts. Be careful not to bend them. Follow the instructions on the Step 11 diagram for capacitor plate meshing, then replace all knobs. Knob identification appears in the Step 1 illustration.

Step 11. This step is for dial alignment.

Reconnect the Receiver and turn it on. Allow it to warm up for about a half hour.

After the warm-up period, tune in to 4 MCS on the Main Tuning Dial and 100 on the logging scale of the Band Spread Dial, and turn on the crystal calibrator (see instructions in the User's Manual).

Set the dial calibrator so that the hairline is in line with the mark on the top of the opening in the dial escutcheon.

Noting that the tuning capacitor plates are in the correct position for the low end of the band (fully meshed), tune for zero beat, ignoring the dial frequency setting.

Loosen the left dial set screw, hold the capacitor pulley to maintain zero beat, then set the dial to exactly 4 MCS. Now tighten the dial set screw again FIRMLY.

Turn the dial to gain access to the other set screw on that dial, and tighten it firmly as well. Repeat the same procedure for the right dial, but using 100 on the logging scale this time.

This completes the dial calibration procedure. Check on other bands; if dial calibration is far out, or not possible to be attained, RF alignment will have to be undertaken.

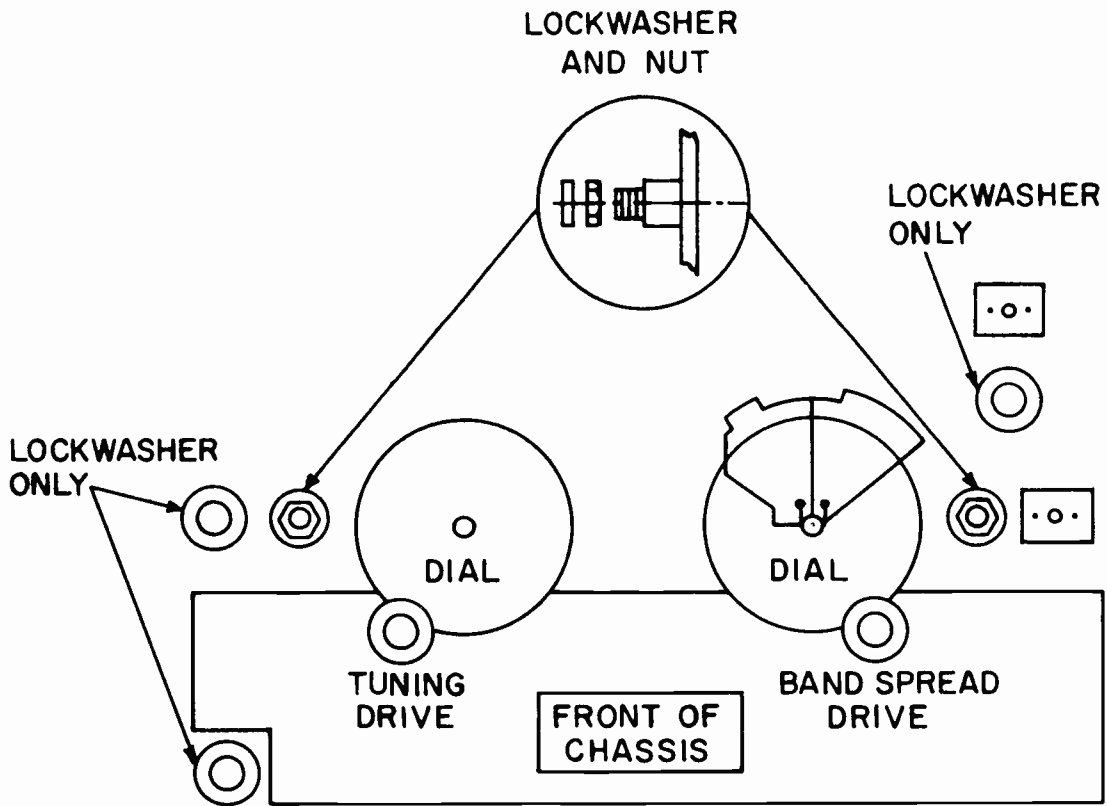

HARDWARE FOR MOUNTING CONTROLS - WHEN PANEL IS REMOVED

STEP 7

SET CAPACITOR PLATES
OUT OF MESH FOR IN-
STALLATION OF THIS KNOB.



SET CONTROLS COUNTER-
CLOCKWISE, SWITCH OFF IF
SO EQUIPPED.

SET CAPACITOR PLATES
IN MESH, PUSH ON POINTER,
THEN KNOB.

KNOB ALIGNMENT POSITIONS- REMAINING SHAFTS HAVE FLATS
IF KNOB ALIGNMENT IS REQUIRED.

REPLACING POINTERS AND KNOBS

STEP 10

Alignment Procedure

This Receiver has been carefully aligned at the factory and should never require any more than a touch-up to retain the peak of its performance. If alignment is necessary, follow the instructions provided below with care.

For the alignment procedure, the equipment listed is required:

Non-metallic alignment tools, general Cement #5097 and #8282, or equivalents.

DC Vacuum-tube Voltmeter.

Signal Generator(s) capable of accurately producing unmodulated signals of:

60 KCS, 455 KCS, 3035 KCS, and RF ranging from .54 MCS to 30.0 MCS.

Alignment must be undertaken with the Receiver out of its cabinet. Remove the chassis from the cabinet as instructed in this Manual. When removed, set the chassis on its end with the power transformer down nearest the table top. This is to permit access to both the top and bottom of the chassis.

Before operating the Receiver, adjust the "S" meter pointer screw on the front face of the meter to set the needle exactly over the zero mark on the scale.

Connect the speaker to the Receiver, plug the set into a source of power, and turn it on.

BEFORE ALIGNMENT, THE RECEIVER MUST BE ALLOWED TO WARM UP FOR AT LEAST A HALF HOUR. This is to assure frequency stability.

KNOB FUNCTION	NOMINAL POSITION
Band Selector.....	7.85 - 15.35 mc band
Band Spread Tuning Dial (arbitrary).....	100
AM/SSB/CW Selector.....	AM
Side Band Selector.....	U
Selectivity Selector.....	.5Kcs
Slot Frequency.....	Counter-clockwise
Slot Depth.....	See AM Reception
Beat Frequency Oscillator.....	0
Noise Limiter.....	Off
AVC.....	Off
Antenna.....	Center
Calibration Reset.....	Center
Send-Receive Switch.....	Receive
Audio & RF Gain.....	Adjust to Test Requirements

After warm-up, set the RF gain control fully counterclockwise without actually turning the set off, and adjust the meter zero control at the rear of the Receiver chassis again for zero on the scale. The AVC switch must be set to a position other than "OFF" for the meter to read.

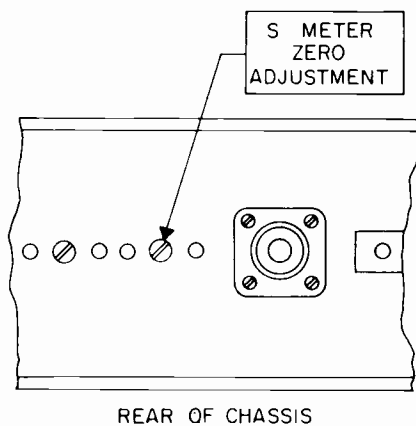

Set all of the front panel controls as shown in the illustration at the start of the alignment procedure. Changes to these settings will be required as the alignment progresses.

Except where noted in the diagrams, the coil slugs are set from the top of the can. Be careful that you are actually turning the proper slug; it is sometimes easy to be adjusting the wrong one, or even to be turning both at once if they happen to be close together inside the coil.

IF ALIGNMENT

Step 1. Connect the VTVM to the junction of L8 and C44 and chassis ground.

Connect the Signal Generator for the 60 KCS First Adjustments to the junction of C28 and T5 and chassis ground.

Apply an unmodulated 60 KCS, and set T6, T7, T8, T9, T10 and T11 for a maximum negative reading. Remember to reduce the IF input signal level as necessary to maintain about -5 volts D.C.

Step 2. Turn the mode switch from AM to CW.

Check that the BFO is set to zero, then adjust T28 for zero beat as heard in the loud speaker.

Return the switch to AM.

Sideband SW to Both.

Selectivity SW to 3 kcs

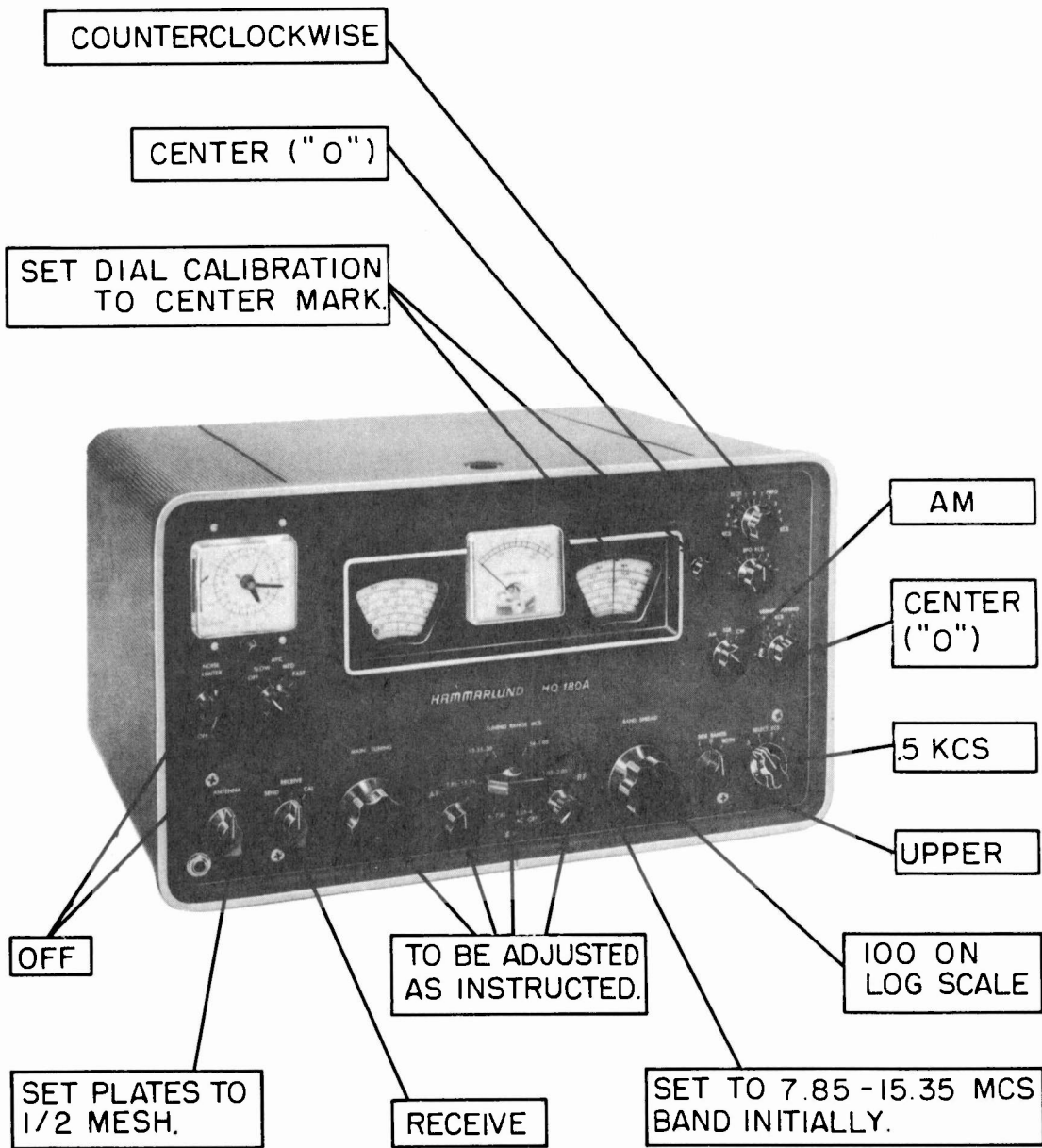

CONTROL SETTING AT START OF ALIGNMENT

Step 3. Disconnect the Signal Generator from V5 and reconnect it to Pin 7 of V2.

Apply on unmodulated 3035 kcs.

Adjust L4, the top and bottom slugs of T5, T4, and T3, and the bottom slug of T2 and peak T1, for a maximum negative reading.

Remember to reduce the IF input signal level as necessary to maintain about -5 volts.

Step 4. Turn the Slot Frequency control to zero, and the Slot Depth control to its mid-position.

Set L3 for minimum meter reading. It may be necessary to raise the IF input level to be sure of indicating the absolute minimum.

Return the generator level and the Slot Frequency and Depth controls to their previous conditions.

Step 5. For alignment of 455 kc/s IF's, leave the signal generator and VTVM as they were in Step 3 and adjust the top and bottom cores of T3, T4, and T5 for maximum negative reading of the VTVM. Remember to reduce the IF input signal level as necessary to maintain about -5 volts.

This completes the IF alignment procedure. For RF alignment continue with Step 6 below.

RF ALIGNMENT

Step 6. All HF Oscillator and RF core adjustments are made from the top of the shield cans. RF trimmer adjustments are made from the bottom of the chassis.

Connect the unmodulated signal generator to the antenna terminal and the generator output ground lead to the antenna ground terminal with the link closed.

Turn the Band Switch to the .54 to 1.05 mc/s band and the Selectivity switch to 1 kc/s. Turn the SideBand Selector to Both.

Set the Antenna control about 30 degrees to the left of vertical (approximately 10 o'clock) and the Main Tuning dial to .60 mc/s.

Set the signal generator frequency to .60 mc/s.

(Step 6 - con't.)

Make sure that the Band Spread adjustable indicator is set at the center marker and the Band Spread dial is set at 100 on the logging scale.

Adjust the top slug in T23, the top slug of T19, and the top slug of T12 for maximum negative reading of the VTVM.

Remember to adjust the generator output and RF gain control to maintain VTVM reading of approximately -5 volts.

Now adjust the top slug of T1 for maximum negative reading on the VTVM.

Set the Main Tuning dial to 1.0 mc/s and the generator frequency to 1.0 mc/s.

Adjust C144, C53 and the Antenna control for maximum negative reading of the VTVM.

Note that the range of the Antenna trimmer is 180 degrees and the control pointer is set for decreasing capacity from horizontal left to horizontal right and should be well within this range from the low frequency to the high frequency adjustments.

Check and if the pointer is at the either end of this range, reset it as required and Adjust T12 as found necessary to keep it within range.

Since the adjustments at each alignment frequency of the band reacts on the other, it is necessary to repeat the adjustments until no improvement is obtained. The final adjustments of the band should be the trimmers C144 and C53 at the high frequency alignment point.

Band Switch to 1.05 to 2.05 position

Main dial to 1.1 mc/s

Generator to 1.1 mc/s

Adjust T23 and bottom slugs of T19 and T13 for maximum negative reading of VTVM.

Generator and Main dial to 2.0 mc/s.

Adjust C145 and C54 and Ant. Comp. for maximum negative reading on the VTVM. Repeat the two frequency adjustments until no further improvement can be noted. Finish with the high frequency adjustments.

(Step 6 - Con't.)

Band Switch to 2.05 - 4.04 mc/s.
Dial and Generator to 2.1 mc/s.
Adjust T24, T14 and top of T20 for maximum negative reading on the VTVM.

Dial and Generator to 4.0 mc/s.
Adjust C146, C55, and Ant. Comp. for maximum negative reading of the VTVM.

Repeat the two frequency adjustments until no further improvement can be noted. Finish with the high frequency adjustments.

Band Switch to 4.0 - 7.85 mc/s band.
Generator and dial to 4.0 mc/s.
Adjust T25, bottom slug of T20 and T15 for maximum negative reading on the VTVM.

Generator and dial to 7.85 mc/s.
Adjust C147, C56, and the Ant. Comp. for maximum negative reading on the VTVM. Repeat the two frequency adjustments until no further improvement can be noted. Finish with the high frequency adjustments.

Band Switch to 7.85 - 15.35 mc/s.
Generator and dial to 7.85 mc/s.
Adjust T26, Top of T21 and T16 for maximum negative reading of the VTVM.

Generator and dial to 15.0 mc/s.
Adjust C148, C57 and Ant. Comp. for maximum negative reading of the VTVM. Repeat the two frequency adjustments until no further improvement can be noted. Finish with the high frequency adjustments.

Band Switch to 15.35 - 30.0 mc/s band
Generator and dial to 15.7 mc/s.
Adjust T27, bottom of T21, and T17 for maximum negative reading of the VTVM.

Generator and dial to 30.0 mc/s.
Adjust C149, C58, and the Ant. Comp. for maximum negative reading of the VTVM. Repeat the two frequency adjustments until no further improvement can be noted. Finish with the high frequency adjustments.

"S" METER ADJUSTMENT

1. Turn receiver off, and if necessary adjust the mechanical zero of pointer with a small bladed screw driver.
2. Turn receiver on, and allow 1/2 hour warm-up.
3. Set Function Switch to receive and turn Sensitivity (RF) control counter-clockwise.
4. Adjust meter "zero adjust potentiometer" R20 (rear of chassis) to zero.
5. The meter sensitivity adjustment, R19, is set to obtain an S9 reading with 50 microvolts input with the RF gain control at max.

NOTE

Usually, R19 will not require readjustment, since the factory setting will vary only slightly as a result of tube changes, ageing, etc. R19 should, therefore, be adjusted only in the event that it is desirable to make the meter more sensitive, or as part of the complete realignment procedure.

ANT. COIL ADJUSTMENTS MCS					
T15	T16	T12	T17	T13	T14
4.0	7.85	.60	15.7	1.1	2.1

CRYSTAL
CALIBRATOR
C50

BFO
(TOP ONLY)
T28

RF COIL ADJUSTMENTS		
COIL LOCATION	FREQ MCS	
T21	TOP	7.9
	BOT.	15.7
T20	TOP	2.1
	BOT.	4.0
T19	TOP	.60
	BOT.	1.1

HF OSC. COIL ADJUSTMENTS MCS		
T27	15.7	
T26	7.9	
T25	4.0	
T24	2.1	
T23	TOP	.60
	BOT.	1.1

C147	C146	C145	C144	C149	C148
7.8	4.0	2.0	1.0	30.0	15.0
HF OSC. TRIMMER ADJUSTMENTS MCS					

T1
TOP &
BOTTOM

SLOT
DEPTH
CONTROL

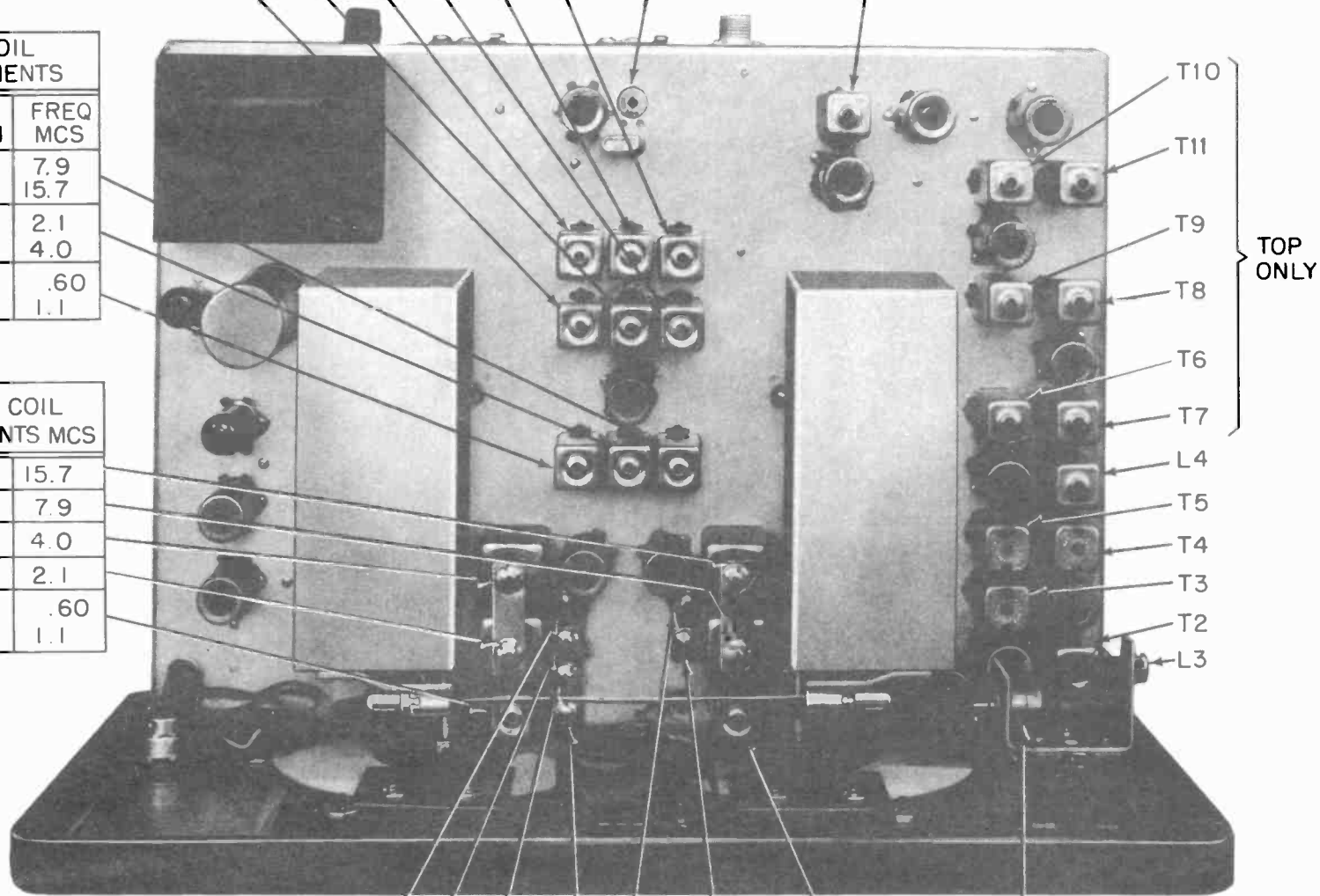

TOP
ONLY

RF TRIMMER ADJUSTMENTS MCS					
C57	C58	C55	C56	C53	C54
15.0	30.0	4.0	7.8	1.0	2.0

T5
455 KCS

T4
455 KCS

T3
455 KCS

C79
3035 KCS

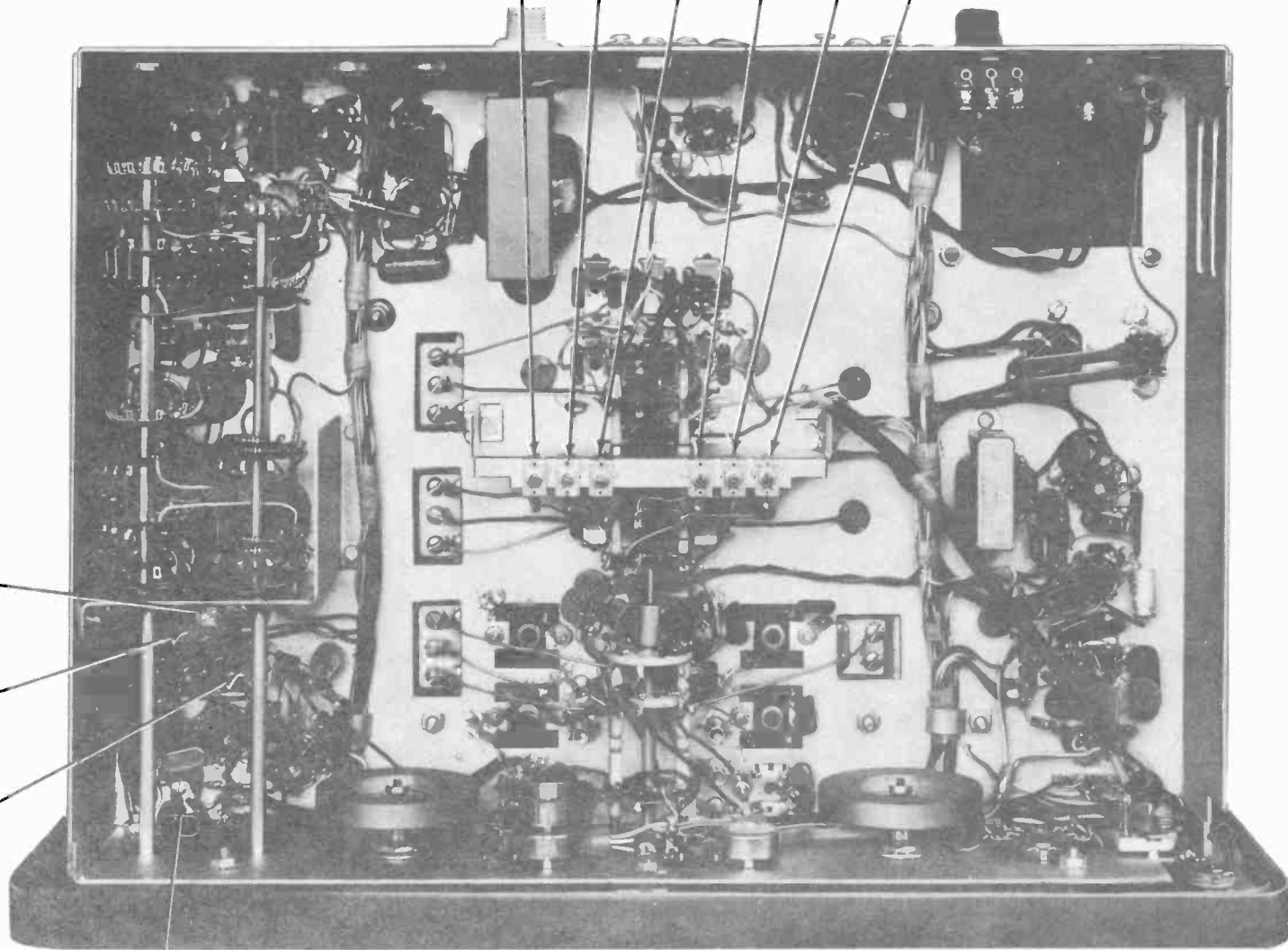

HAMMARLUND MFG. CO.
MARS HILL N.C.

MODEL NO. HQ-180-

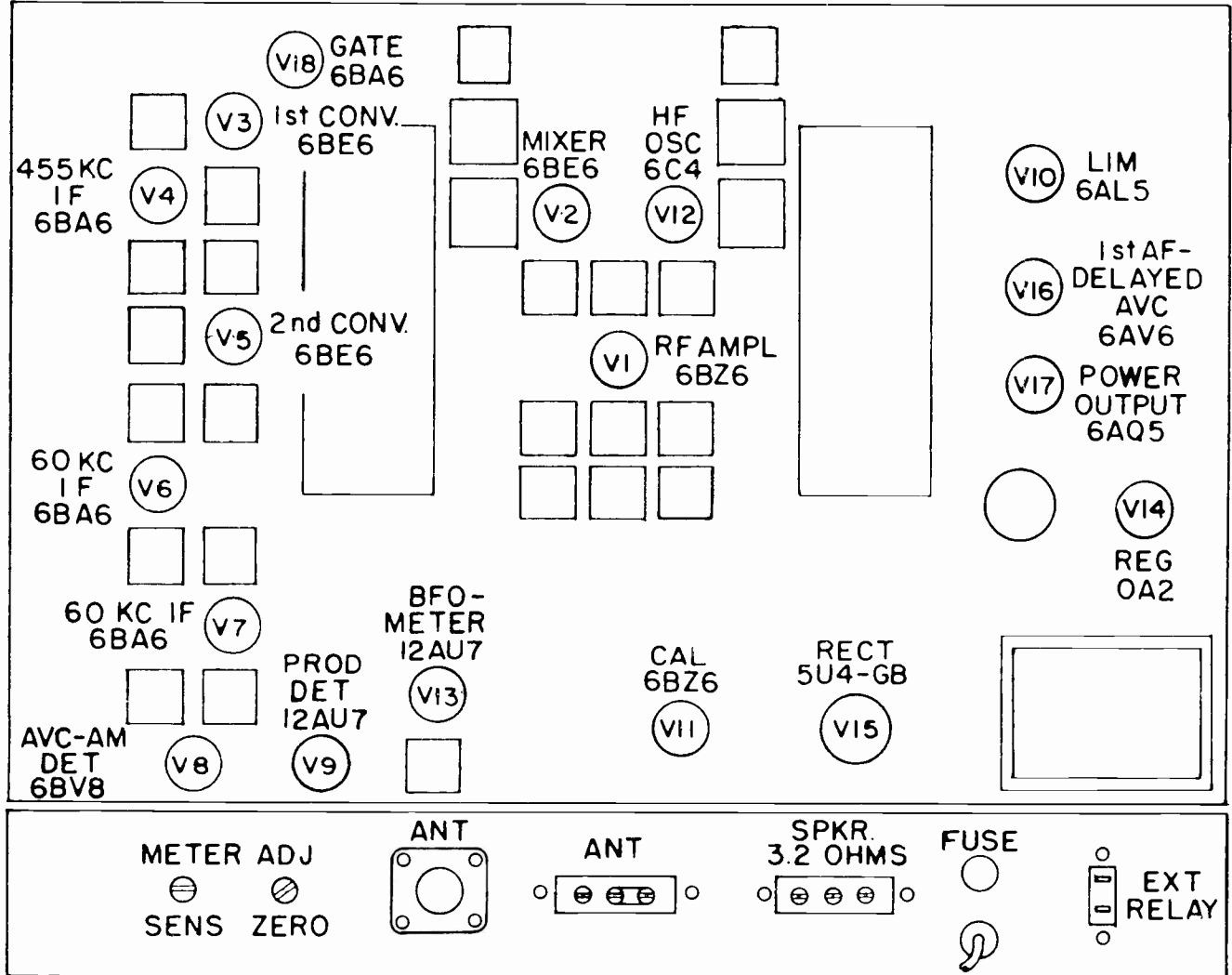

PT. 26496

TUBE LOCATION LABEL

HAMMARLUND MFG. CO.
MARS HILL, N.C.

MODEL NO. HQ-180-XE

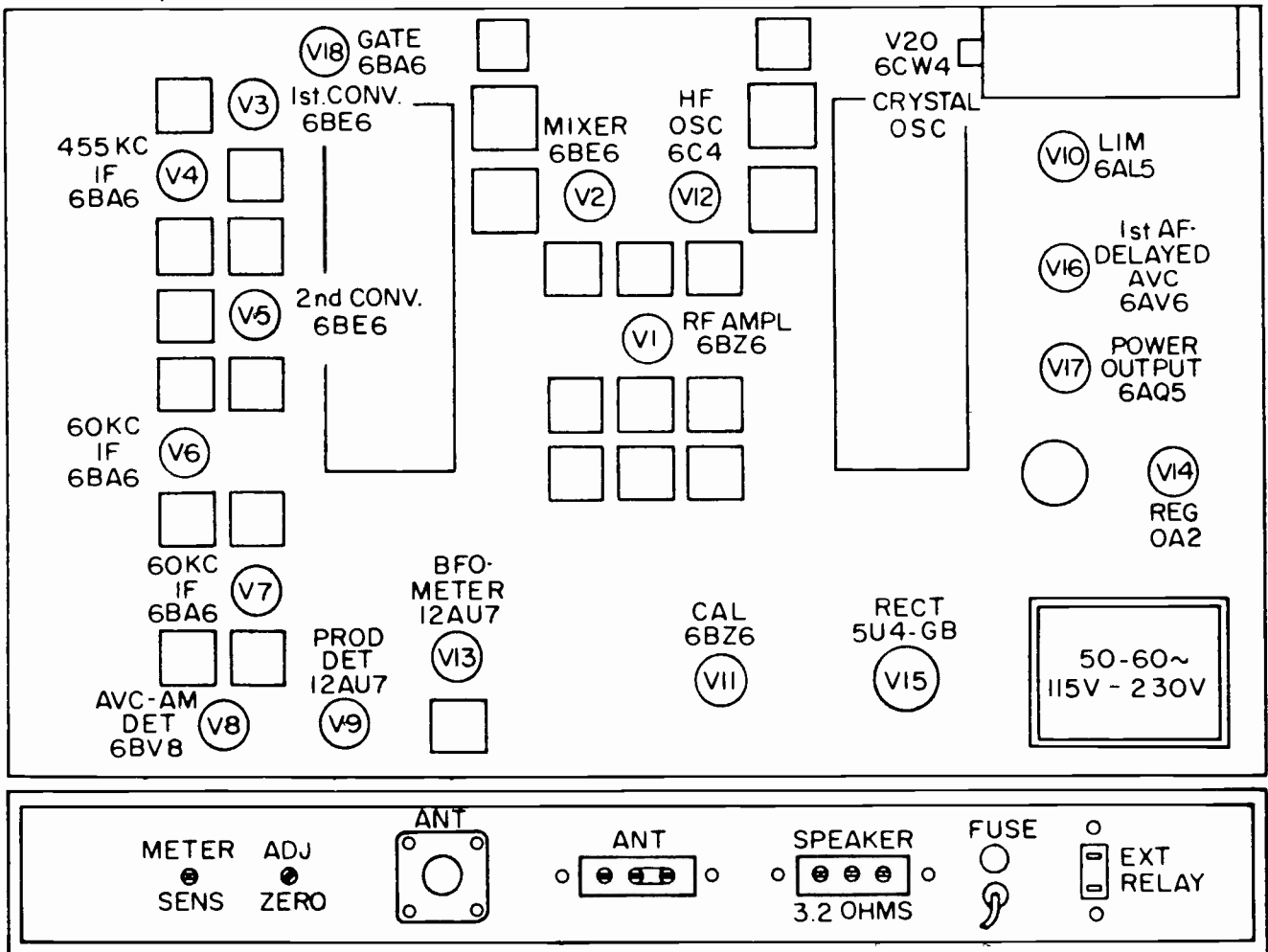

PT. 39160-1

TUBE LOCATION LABEL

HAMMARLUND MFG. CO
MARS HILL, N. C.

MODEL NO. HQ - 180 - A

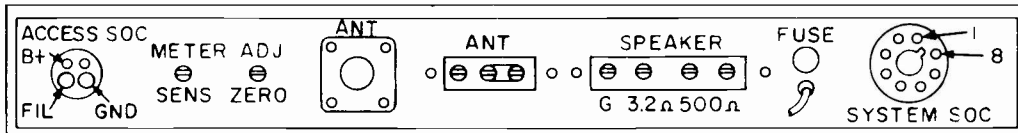
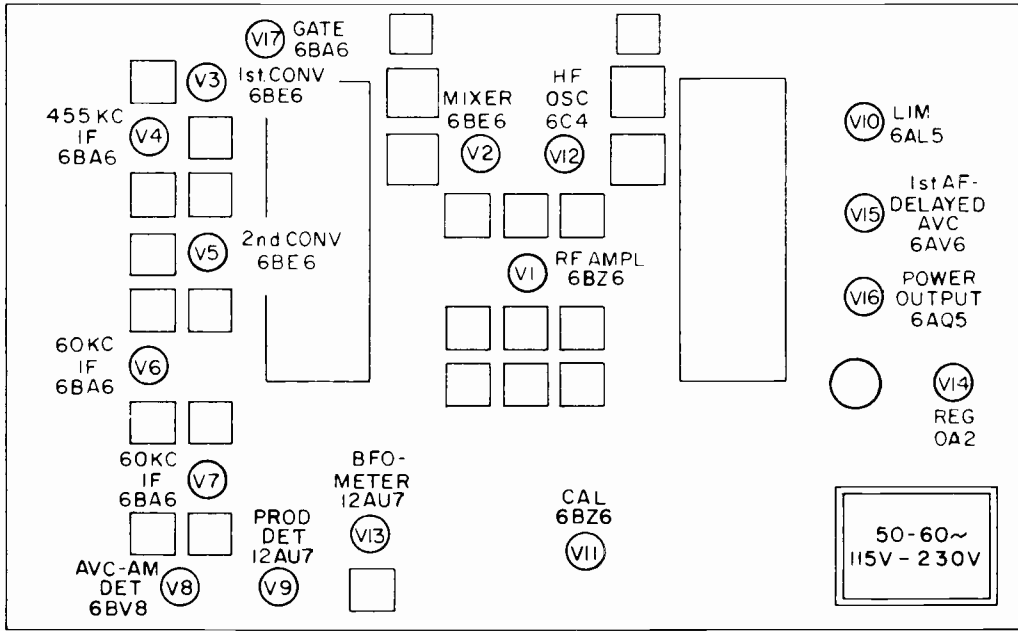

PT 2418-2-00009

TUBE LOCATION LABEL

VIEW FROM WIRING
SIDE OF SOCKET, OR
FROM PIN END OF PLUG.

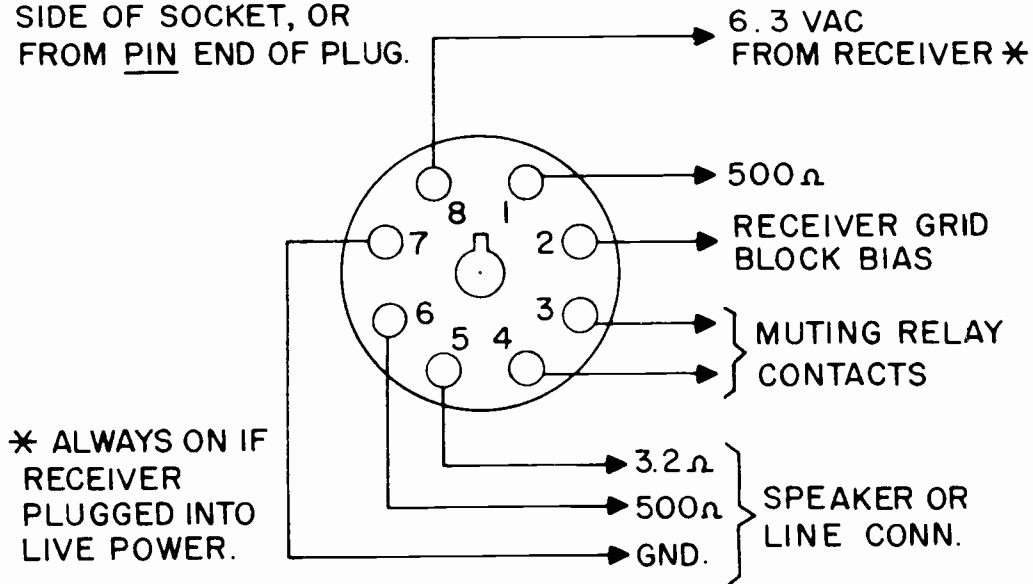

SYSTEM SOCKET CONNECTIONS

"A" SERIES ONLY

HAMMARLUND MFG. CO.
MARS HILL, N.C.

MODEL NO. HQ - 180 - AX

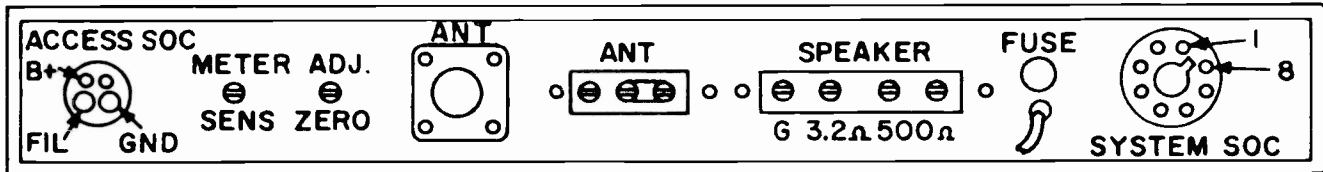
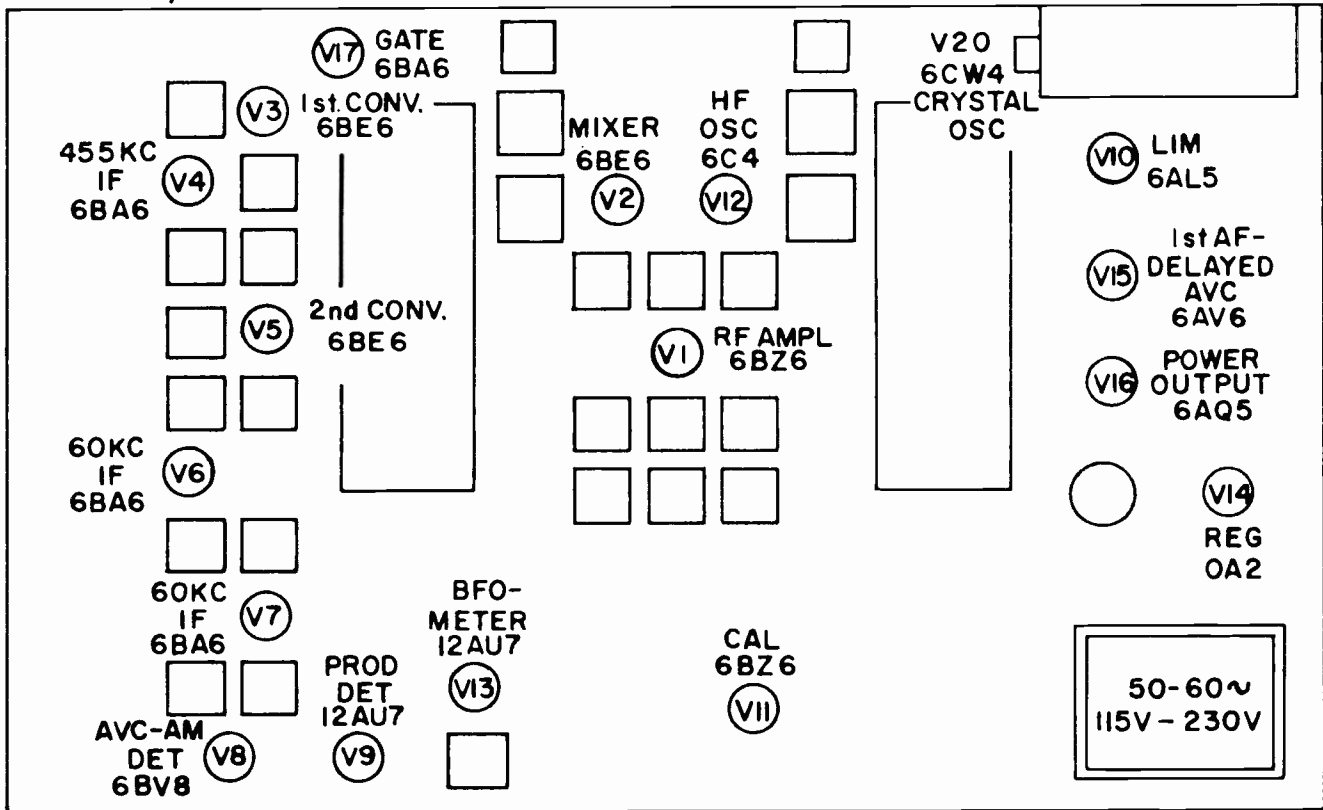

PT. 2418-2-00010

TUBE LOCATION LABEL

HQ-180

TABLE 2. TUBE SOCKET RESISTANCES

Measured with VT Ohmeter; Power Plug and Antenna Disconnected; Unless otherwise specified, Band and Dial 10 MC, AM, AVC OFF, 3 KC Both Sidebands, Rec., Limiter OFF, RF Gain Max., AF Gain Min.

TUBE		SOCKET PIN NUMBERS								
		1	2	3	4	5	6	7	8	9
V1	RF 6BZ6	480K	180 RF 1.7K(MIN)	--	0	19K	44K	0	--	--
V2	MIXER #1 6BE6	47K	160	0	--	21K	25K	0	--	--
V3	MIXER #2 6BE6	100K	470	0	--	21K	45K INF(1MC)	1.8	--	--
V4	IF AMP 6BA6	1.1 MEG	0	--	0	19K	33K	180 RF 10K(MIN)	--	--
V5	MIXER #3 6BE6	22K	.8	0	--	22K	44K	1.2 MEG	--	--
V6	IF AMP 6BA6	1.47 MEG	0	--	0	19K	61K	68	--	--
V7	IF AMP 6BA6	470K	0	--	0	20K	60K	68	--	--
V8	DET. AVC 6BV8	560	17	30K	0	--	47K	70	0	4.7K
V9	PROD DET 12AU7	INF 20K(SSB)	470K	820	--	--	55K	100K	820	0
V10	LIMITER 6AL5	210K	1.4 MEG 200K(LIM ON)	0	--	220K	0	1.5 MEG 470K(LIM ON)	--	--
V11	CAL. 6BZ6	470K	4.7K	--	0	INF 500K(CAL)	INF 110K(CAL)	4.7K	--	--
V12	HF OSC. 6C4	24K	--	--	0	24K	100K	27	--	--
V13	BFO METER 12AU7	17K	0	1K	--	--	INF 20K(SSB)	545K	47K	0
V14	VOLT. REG. 0A2	24K	--	--	--	24K	--	0	--	--
V15	RECT 5U4-GB	--	20K	--	38	21K TIE PT.	30	AC LINE TIE PT.	20K	--
V16	AF AVC 6AV6	50 APPROX	5.6K	--	0	235K	235K	540K	--	--
V17	POWER AMP. 6AQ5	500K	430	--	0	22K	21K	500K	--	--
V18	IF GATE 6BA6	1.1 MEG	0	--	0	21K	INF 61K(1MC)	1K	--	--

HQ-180

TABLE 1. TUBE SOCKET VOLTAGES

Measured with VTVM; 117 Line Volts, No Antenna; Unless otherwise specified, Band and Dial 10 MC, AM, AVC OFF, 3KC Both Sidebands, Rec., Limiter OFF, RF Gain Max., AF Gain Min.

TUBE		SOCKET PIN NUMBERS								
		1	2	3	4	5	6	7	8	9
V1	RF 6BZ6	0	1.5 RF 5.8(MIN)	6.3 AC	0	245	105	0	--	--
V2	MIXER #1 6BE6	-2.8 APPROX	1.35	0	6.3 AC	245	110	0	--	--
V3	MIXER #2 6BE6	-2.4 APPROX	2	0	6.3 AC	140	⁷⁴ 0(1 MC)	0	--	--
V4	IF AMP. 6BA6	0	0	6.3 AC	0	245	110	2.1 RF 29(MIN)	--	--
V5	MIXER #3 6BE6	-7.4 APPROX	0	0	6.3 AC	250	84	0	--	--
V6	IF AMP. 6BA6	0	0	6.3 AC	0	240	83	1.0	--	--
V7	IF AMP. 6BA6	0	0	6.3 AC	0	230	82	1.0	--	--
V8	DET. AVC 6BV8	5	0	235	0	--	-.24	0	0	-4
V9	PROD DET 12AU7	220(SSB)	0	7.0(SSB)	6.3 AC	6.3 AC	100(SSB)	0	7.0(SSB)	0
V10	LIMITER 6AL5	36(OFF) .24(MAX)	30(OFF) 0(MAX)	0	6.3 AC	36(OFF) .24(MAX)	0	30(OFF) 0(MAX)	--	--
V11	CAL. 6BZ6	-60(CAL) APPROX	9.0(CAL)	6.3 AC	0	75(CAL)	88(CAL)	9.0(CAL)	--	--
V12	HF OSC. 6C4	130	--	6.3 AC	0	130	-6.0	0	--	--
V13	BFO METER 12AU7	80	0	3.7	6.3 AC	6.3 AC	200(SSB)	125(SSB)	125(SSB)	0
V14	VOLT. REG. 0A2	150	--	--	--	150	--	--	--	--
V15	RECT. 5U4-GB	6.3 AC TIE PT.	260	--	253 AC	245 TIE PT.	253 AC	117 AC TIE PT.	260	--
V16	AF AVC 6AV6	0	1.3	6.3 AC	0	0	0	115	--	--
V17	POWER AMP 6AQ5	0	13	6.3 AC	0	275	250	--	--	--
V18	IF GATE 6BA6	0	0	6.3 AC	0	140	0 88(IMC)	.02 4(IMC)	--	--

HQ-180-XE

TABLE 2. TUBE SOCKET RESISTANCES

Measured with VT Ohmeter; Power Plug and Antenna Disconnected; Unless otherwise specified, Band and Dial 10 MC, AM, AVC OFF, 3 KC Both Sidebands, Rec., Limiter OFF, RF Gain Max., AF Gain Min.

TUBE		SOCKET PIN NUMBERS								
		1	2	3	4	5	6	7	8	9
V1	RF 6BZ6	480K	180 RF 1.7K(MIN)	--	0	19K	44K	0	--	--
V2	MIXER #1 6BE6	47K	160	0	--	21K	25K	0	--	--
V3	MIXER #2 6BE6	100K	470	0	--	21K	45K INF(1MC)	1.8	--	--
V4	IF AMP 6BA6	1.1 MEG	0	--	0	19K	33K	180 RF 10K(MIN)	--	--
V5	MIXER #3 6BE6	22K	.8	0	--	22K	44K	1.2 MEG	--	--
V6	IF AMP 6BA6	1.47 MEG	0	--	0	19K	61K	68	--	--
V7	IF AMP 6BA6	470K	0	--	0	20K	60K	68	--	--
V8	DET. AVC 6BV8	560	17	30K	0	--	47K	70	0	4.7K
V9	PROD DET 12AU7	INF 20K(SSB)	470K	820	--	--	55K	100K	820	0
V10	LIMITER 6AL5	210K	1.4 MEG 200K(LIM ON)	0	--	220K	0	1.5 MEG 470K(LIM ON)	--	--
V11	CAL. 6BZ6	470K	4.7K	--	0	INF 500K(CAL)	INF 110K(CAL)	4.7K	--	--
V12	HF OSC. 6C4	24K	--	--	0	24K	100K	27	--	--
V13	BFO METER 12AU7	17K	0	1K	--	--	INF 20K(SSB)	545K	47K	0
V14	VOLT. REG. OA2	24K	--	--	--	24K	--	0	--	--
V15	RECT. 5U4-GB	--	20K	--	28	21K TIE PT.	30	AC LINE TIE PT.	20K	--
V16	AF AVC 6AV6	50 APPROX	5.6K	--	0	235K	235K	540K	--	--
V17	POWER AMP. 6AQ5	500K	430	--	0	22K	21K	500K	--	--
V18	IF GATE 6BA6	1.1 MEG	0	--	0	21K	INF 61K(1MC)	1K	--	--

HQ-180-XE

TABLE 1. TUBE SOCKET VOLTAGES

Measured with VTVM: 117 Line Volts, No Antenna; Unless otherwise specified, Band and Dial 10 MC, AM, AVC OFF, 3KC Both Sidebands, Rec., Limiter OFF, RF Gain Max., AF Gain Min.

TUBE		SOCKET PIN NUMBERS								
		1	2	3	4	5	6	7	8	9
V1	RF 6BZ6	0	1.5 RF 5.8(MIN)	6.3 AC	0	245	105	0	--	--
V2	MIXER #1 6BE6	-2.8 APPROX	1.35	0	6.3 AC	245	110	0	--	--
V3	MIXER #2 6BE6	-2.4 APPROX	2	0	6.3 AC	140	74 0(1 MC)	0	--	--
V4	IF AMP. 6BA6	0	0	6.3 AC	0	245	110	2.1 RF 29(MIN)	--	--
V5	MIXER #3 6BE6	-7.4 APPROX	0	0	6.3 AC	250	84	0	--	--
V6	IF AMP. 6BA6	0	0	6.3 AC	0	240	83	1.0	--	--
V7	IF AMP. 6BA6	0	0	6.3 AC	0	230	82	1.0	--	--
V8	DET. AVC 6BV8	5	0	235	0	--	-.24	0	0	-4
V9	PROD DET 12AU7	220(SSB)	0	7.0(SSB)	6.3 AC	6.3 AC	100(SSB)	0	7.0(SSB)	0
V10	LIMITER 6AL5	36(OFF) .24(MAX)	30(OFF) 0(MAX)	0	6.3 AC	36(OFF) .24(MAX)	0	30(OFF) 0(MAX)	--	--
V11	CAL. 6BZ6	-60(CAL) APPROX	9.0(CAL)	6.3 AC	0	75(CAL)	88(CAL)	9.0(CAL)	--	--
V12	HF OSC. 6C4	130	--	6.3 AC	0	130	-6.0	0	--	--
V13	BFO METER 12AU7	80	0	3.7	6.3 AC	6.3 AC	200(SSB)	125(SSB)	125(SSB)	0
V14	VOLT. REG. 0A2	150	--	--	--	150	--	--	--	--
V15	RECT. 5U4-GB	6.3 AC TIE PT.	260	--	253 AC	245 TIE PT.	253 AC	117 AC TIE PT.	260	--
V16	AF AVC 6AV6	0	1.3	6.3 AC	0	0	0	115	--	--
V17	POWER AMP 6AQ5	0	13	6.3 AC	0	275	250	--	--	--
V18	IF GATE 6BA6	0	0	6.3 AC	0	140	0 88(IMC)	.02 4(IMC)	--	--

HQ-180-A

TABLE 1 TUBE SOCKET VOLTAGES

MEASURED WITH VTVM; 117 LINE VOLTS; NO ANTENNA; UNLESS OTHERWISE SPECIFIED, BAND AND DIAL 10 MC, AM, AVC OFF, 3 KC BOTH SIDEBANDS, REC., LIMITER OFF, RF GAIN MAX., AF GAIN MIN.

TUBE		SOCKET PIN NUMBERS								
		1	2	3	4	5	6	7	8	9
V 1	RF 6BZ6	0	1.5 RF 5.8 (min)	6.3 AC	0	245	105	0	--	--
V 2	Mixer #1 6BE6	-2.8 approx.	1.35	0	6.3 AC	245	110	0	--	--
V 3	Mixer #2 6BE6	-2.4 approx.	2	0	6.3 AC	250	74 0 (1 mc)	0	--	--
V 4	IF Amp 6BA6	0	0	6.3 AC	0	245	110	2.1 RF 29 (min)	--	--
V 5	Mixer #3 6BE6	-7.4 approx.	0	0	6.3 AC	250	84	0	--	--
V 6	IF Amp 6BA6	0	0	6.3 AC	0	240	83	1.0	--	--
V 7	IF Amp 6BA6	0	0	6.3 AC	0	230	82	1.0	--	--
V 8	DET AVC 6BV8	5	0	235	0	--	-.24	0	0	-4
V 9	Prod Det 12AU7	220 (SSB)	0	7.0 (SSB)	6.3 AC	6.3 AC	100 (SSB)	0	7.0 (SSB)	0
V 10	Limiter 6AL5	36 (off) .24 (max)	30 (off) 0 (max)	0	6.3 AC	36 (off) .24 (max)	0	30 (off) 0 (max)	--	--
V 11	Cal 6BZ6	-60 (cal) approx.	9.0 (cal)	6.3 AC	0	75 (cal)	88 (cal)	9.0 (cal)	--	--
V 12	HF Osc. 6C4	130	--	6.3 AC	0	130	-6.0	0	--	--
V 13	BFO Meter 12AU7	80	0	3.7	6.3 AC	6.3 AC	200 (SSB)	125 (SSB)	125 (SSB)	0
V 14	Volt. Reg. OA2	150	--	--	--	150	--	--	--	--
V 15	AF AVC 6AV6	0	1.3	6.3 AC	0	0	0	115	--	--
V 16	Power Amp 6AQ5	0	13	6.3 AC	0	275	250	--	--	--
V 17	IF Gate 6BA6	0	0	6.3 AC	0	250	0 88 (1 mc)	.02 4 (1 mc)	--	--
Systems Socket		0	A.V.C.	105	105	0	0	0	6.3 V.A.C.	--
Ace Socket		0	0	300 v D.C.	6.3 V.A.C.	--	--	--	--	--

HQ-180-A

TABLE 2 TUBE SOCKET RESISTANCES

MEASURED WITH VT OHMMETER; POWER PLUG AND ANTENNA DISCONNECTED; UNLESS OTHERWISE SPECIFIED, BAND AND DIAL 10 MC, AM, AVC OFF, 3 KC BOTH SIDEBANDS, REC., LIMITER OFF, RF GAIN MAX., AF GAIN MIN.

TUBE		SOCKET PIN NUMBERS								
		1	2	3	4	5	6	7	8	9
V 1	RF 6BZ6	480K	180 RF 1.7K (min)	--	0	19K	44K	0	--	--
V 2	Mixer #1 6BE6	47K	160	0	--	21K	25K	0	--	--
V 3	Mixer #2 6BE6	100K	470	0	--	21K	45K Inf (1 mc)	1.8	--	--
V 4	IF Amp 6BA6	1.1 meg	0	--	0	19K	33K	180 RF 10K (min)	--	--
V 5	Mixer #3 6BE6	22K	.8	0	--	22K	44K	1.2 MEG	--	--
V 6	IF Amp 6BA6	1.47 MEG	0	--	0	19K	61K	68	--	--
V 7	IF Amp 6BA6	470K	0	--	0	20K	60K	68	--	--
V 8	Det. AVC 6BV8	560	17	30K	0	--	47K	70	0	4.7K
V 9	Prod Det 12AU7	INF 20K (SSB)	470K	820	--	--	55K	100K	820	0
V 10	Limiter 6AL5	210K	1.4 MEG 200K (LIM ON)	0	--	220K	0	1.5 MEG 470K (LIM ON)	--	--
V 11	Cal. 6BZ6	470K	4.7K	--	0	INF 500K (CAL)	INF 110K (CAL)	4.7K	--	--
V 12	HF Osc 6C4	24K	--	--	0	24K	100K	27	--	--
V 13	BFO Meter 12AU7	17K	0	1K	--	---	INF 20K (SSB)	545K	47K	0
V 14	Volt. Reg. OA2	24K	--	--	--	24K	--	0	--	--
V 15	AF AVC 6AV6	50 Approx.	5.6K	--	0	235K	235K	540K	--	--
V 16	Power Amp 6AQ5	500K	430	--	0	22K	21K	500K	--	--
V 17	IF Gate 6BA6	1.1 MEG	0	--	0	21K	INF 61K (MC)	1K	--	--
Systems Socket		0	2.2 MEG	B + 20K	B + 20K	0	∞	0	0	
Ace Socket		0	∞	B + 20K	0					

HQ-180-AX

TABLE 1 TUBE SOCKET VOLTAGES

MEASURED WITH VTVM; 117 LINE VOLTS; NO ANTENNA; UNLESS OTHERWISE SPECIFIED, BAND AND DIAL 10 MC, AM, AVC OFF, 3 KC BOTH SIDEBANDS, REC., LIMITER OFF, RF GAIN MAX., AF GAIN MIN.

TUBE		SOCKET PIN NUMBERS								
		1	2	3	4	5	6	7	8	9
V 1	RF 6BZ6	0	1.5 RF 5.8 (min)	6.3 AC	0	245	105	0	--	--
V 2	Mixer #1 6BE6	-2.8 approx.	1.35	0	6.3 AC	245	110	0	--	--
V 3	Mixer #2 6BE6	-2.4 approx.	2	0	6.3 AC	250	74 0 (1 mc)	0	--	--
V 4	IF Amp 6BA6	0	0	6.3 AC	0	245	110	2.1 RF 29 (min)	--	--
V 5	Mixer #3 6BE6	-7.4 approx.	0	0	6.3 AC	250	84	0	--	--
V 6	IF Amp 6BA6	0	0	6.3 AC	0	240	83	1.0	--	--
V 7	IF Amp 6BA6	0	0	6.3 AC	0	230	82	1.0	--	--
V 8	DET AVC 6BV8	5	0	235	0	--	-.24	0	0	-4
V 9	Prod Det 12AU7	220 (SSB)	0	7.0 (SSB)	6.3 AC	6.3 AC	100 (SSB)	0	7.0 (SSB)	0
V 10	Limiter 6AL5	36 (off) .24 (max)	30 (off) 0 (max)	0	6.3 AC	36 (off) .24 (max)	0	30 (off) 0 (max)	--	--
V 11	Cal 6BZ6	-60 (cal) approx.	9.0 (cal)	6.3 AC	0	75 (cal)	88 (cal)	9.0 (cal)	--	--
V 12	HF Osc. 6C4	130	--	6.3 AC	0	130	-6.0	0	--	--
V 13	BFO Meter 12AU7	80	0	3.7	6.3 AC	6.3 AC	200 (SSB)	125 (SSB)	125 (SSB)	0
V 14	Volt. Reg. OA2	150	--	--	--	150	--	--	--	--
V 15	AF AVC 6AV6	0	1.3	6.3 AC	0	0	0	115	--	--
V 16	Power Amp 6AQ5	0	13	6.3 AC	0	275	250	--	--	--
V 17	IF Gate 6BA6	0	0	6.3 AC	0	250	88 ⁰ (1 mc)	4 ⁰² (1 mc)	--	--
Systems Socket		0	A.V.C.	105	105	0	0	0	6.3 V.A.C.	--
Ace Socket		0	0	300 v D.C.	6.3 V.A.C.	--	--	--	--	--

V20 6CW4 crystal dsc* Pin 2 78V+, Pin 4 8.6V-, Pin 8 .08V+, Pin 10 6.3V AC

*Readings taken with switch in crystal position with 3 MC crystal in use.

HQ-180-AX

TABLE 2 TUBE SOCKET RESISTANCES

MEASURED WITH VT OHMMETER; POWER PLUG AND ANTENNA DISCONNECTED; UNLESS OTHERWISE SPECIFIED, BAND AND DIAL 10 MC, AM, AVC OFF, 3 KC BOTH SIDEBANDS, REC., LIMITER OFF, RF GAIN MAX., AF GAIN MIN.

TUBE		SOCKET PIN NUMBERS								
		1	2	3	4	5	6	7	8	9
V 1	RF 6BZ6	480K	180 RF 1.7K (min)	--	0	19K	44K	0	--	--
V 2	Mixer #1 6BE6	47K	160	0	--	21K	25K	0	--	--
V 3	Mixer #2 6BE6	100K	470	0	--	21K	45K Inf (1 mc)	1.8	--	--
V 4	IF Amp 6BA6	1.1 meg	0	--	0	19K	33K	180 RF 10K (min)	--	--
V 5	Mixer #3 6BE6	22K	.8	0	--	22K	44K	1.2 MEG	--	--
V 6	IF Amp 6BA6	1.47 MEG	0	--	0	19K	61K	68	--	--
V 7	IF Amp 6BA6	470K	0	--	0	20K	60K	68	--	--
V 8	Det. AVC 6BV8	560	17	30K	0	--	47K	70	0	4.7K
V 9	Prod Det 12AU7	INF 20K (SSB)	470K	820	--	--	55K	100K	820	0
V 10	Limiter 6AL5	210K	1.4 MEG 200K (LIM ON)	0	--	220K	0	1.5 MEG 470K (LIM ON)	--	--
V 11	Cal. 6BZ6	470K	4.7K	--	0	INF 500K (CAL)	INF 110K (CAL)	4.7K	--	--
V 12	HF Osc 6C4	24K	--	--	0	24K	100K	27	--	--
V 13	BFO Meter 12AU7	17K	0	1K	--	---	INF 20K (SSB)	545K	47K	0
V 14	Volt. Reg. 0A2	24K	--	--	--	24K	--	0	--	--
V 15	AF AVC 6AV6	50 Approx.	5.6K	--	0	235K	235K	540K	--	--
V 16	Power Amp 6AQ5	500K	430	--	0	22K	21K	500K	--	--
V 17	IF Gate 6BA6	1.1 MEG	0	--	0	21K	INF 61K (MC)	1K	--	--
Systems Socket		0	2.2 MEG	B + 20K	B + 20K	0	∞	0	0	
Ace Socket		0	∞	B + 20K	0					

V Pin 2 70K, Pin 4 100K, Pin 8 Infinity, Pin 10 .4 ohms

PARTS LIST HQ-180

<u>SCHEMATIC DESIGNATION</u>	<u>DESCRIPTION</u>	<u>HAMMARLUND PART NO.</u>
CAPACITORS		
C1, A-C	Variable, Main Tuning	T41604-G1
C2, A-I	Variable, Band Spread Tuning	T41604-G2
C3, C8, C31, C51, C157	Fixed, Silver - Dur Mica DM-15 100 mmf, 500 W.V.D.C.	K23006-1
C4, C5, C6, C7, C9, C28	Fixed, Ceramic Disc .01 mfd, 600 W.V.D.C.	M23034-19
C10, C11, C15, C17, C18, C21, C32, C41, C47, C75, C76, C124, C130, C133, C135, C139, C141, C152	Fixed, Ceramic Disc .02 mfd, 600 W.V.D.C.	M23034-9
C12, C33, C36, C38, C40, C46, C136, C137	Fixed, Silver - Dur Mica DM-15 20 mmf, 500 W.V.D.C.	K23006-17
C13, C89, C97, C111 C113, C120, C123	Fixed, Silver - Dur Mica DM-15 560 mmf, 500 W.V.D.C.	K23027-6
C14	Fixed, Silver - Dur Mica DM-15 3 mmf, 500 W.V.D.C.	K23006-18
C16, C93, C101 C103, C114	Fixed, Ceramic Disc, .04 mfd, 600 W.V.D.C.	K23034-12
C19, C20, C85	Fixed, Ceramic Disc, .01 mfd, 10%, 1000 W.V.D.C.	K23034-25
C22, C27	Fixed, Silver - Dur Mica DM-15, 15 mmf, 300 W.V.D.C.	K23006-35
C23	Fixed, Silver - Dur Mica DM-15, 1200 mmf, 500 W.V.D.C.	K23027-4
C24	Fixed, Mylar, .033 mfd, 200 W.V.D.C.	K23044-1
C25	Variable, Slot Tuning	K42041-1
C26	Fixed, Silver - Dur Mica DM-15, 7 mmf, 500 W.V.D.C.	K23006-24
C28, C104, C110, C115 C117, C122	Fixed, Silver - Dur Mica DM-15, 780 mmf, 500 W.V.D.C.	K23006-39
C29	Fixed, Silver - Dur Mica DM-15, 47 mmf, 300 W.V.D.C.	K23006-47
C30, C63, C64, C78, C143	Fixed, Silver - Dur Mica DM-15, 24 mmf, 500 W.V.D.C.	K23006-7
C34, C37	Fixed, Ceramic Disc, Temp. Comp. 330N750	K23010-9
C35	Fixed, Ceramic Disc, 500 mmf, 1000 W.V.D.C.	K23034-13
C39, C42	Fixed, Silver - Dur Mica DM-15, 10 mmf, 500 W.V.D.C.	K23006-8
C43	Fixed, Ceramic Disc, .002 mfd, 1000 W.V.D.C.	M23034-18
C44, C45	Fixed, Dur-Paper, .1 mfd, 200 W.V.D.C.	K23045-3
C48, C87, C131	Fixed, Dur-Paper, .047 mfd, 400 W.V.D.C.	K23045-2
C49, C95, C105	Variable, Calibrator, 8-50 mmf	K23038-5
C50	Variable, Antenna Tuning	K34454-G24
C52	Variable, Mica Trimmer, 1.5 - 20 mmf	K23043-6
C53, C54, C55, C56, C57, C58	Fixed, Ceramic Disc, Temp. Comp. 27N470	K23010-26
C59	Fixed, Ceramic Disc, Temp. Comp. 27N220	K23010-25
C60	Fixed, Ceramic Disc, Temp. Comp. 27N470	K23010-23
C61	Fixed, Ceramic Disc, Temp. Comp. 27N750	K23010-24
C62	Fixed, Silver - Dur Mica DM-15, 60 mmf, 300 W.V.D.C.	K-23006-51
C65	Fixed, Silver - Dur Mica DM-15, 85 mmf, 500 W.V.D.C.	K23006-3
C66		

SCHEMATIC
DESIGNATION

DESCRIPTION

HAMMARLUND
PART NO.

C67	Fixed, Silver - Dur Mica DM-15, 150 mmf, 300 W. V. D. C.	K23006-53
C68, C80	Fixed, Silver - Dur Mica DM-15, 220 mmf, 500 W. V. D. C.	K23006-10
C69	Fixed, Silver - Dur Mica DM-15, 180 mmf, 300 W. V. D. C.	K23006-60
C70	Fixed, Silver - Dur Mica DM-15, 333 mmf, 300 W. V. D. C.	K23006-61
C71	Fixed, Silver - Dur Mica DM-15, 673 mmf, 300 W. V. D. C.	K23006-57
C72	Fixed, Silver - Dur Mica DM-15, 1030 mmf, 300 W. V. D. C.	K23027-19
C73	Fixed, Silver - Dur Mica DM-15, 363 mmf, 300 W. V. D. C.	K23006-76
C74	Fixed, Silver - Dur Mica DM-15, 438 mmf, 300 W. V. D. C.	K23006-75
C77	Fixed, Ceramic Disc, Temp. Comp. 100N470	K23010-30
C79	Variable, Crystal Phasing 1.5-9.1 mmf	K23057-1
C81	Fixed, Silver - Dur Mica DM-15, 1000 mmf, 300 W. V. D. C.	K23027-9
C82, A-D	Fixed, Electrolytic, 60-40-40-40 mfd	K15504-71
C83, C84	Fixed, Ceramic Disc, .01 mfd, 1400 W. V. D. C.	K23034-26
C86, C94	Fixed, Silver - Dur Mica DM-15, 31 mmf, 500 W. V. D. C.	K23006-15
C88, C90, C96, C98	Fixed, Silver - Dur Mica DM-15, 29 mmf, 500 W. V. D. C.	K23006-16
C91, C99	Fixed, Silver - Dur Mica DM-15, 28 mmf, 500 W. V. D. C.	K23006-19
C92, C100	Fixed, Silver - Dur Mica DM-15, 27 mmf, 500 W. V. D. C.	K23006-20
C102, C109, C118, C153 C154, C155	Fixed, Silver - Dur Mica DM-15, 9 mmf, 500 W. V. D. C.	K23006-21
C106	Fixed, Silver - Dur Mica DM-15, 10 mmf, 500 W. V. D. C.	K23006-22
C107, C116	Fixed, Silver - Dur Mica DM-15, 14 mmf, 500 W. V. D. C.	K23006-25
C108, C119	Fixed, Silver - Dur Mica DM-15, 21 mmf, 500 W. V. D. C.	K23006-26
C112, C121	Fixed, Silver - Dur Mica DM-15, 16 mmf, 500 W. V. D. C.	K23006-23
C125	Fixed, Silver - Dur Mica DM-15, 47 mmf, 500 W. V. D. C.	K23006-6
C126, C127	Fixed, Mylar, .01 mfd, 400 W. V. D. C.	K23044-2
C128	Fixed, Ceramic Disc, .001 mfd, 500 W. V. D. C.	K2304-30
C129	Variable, BFO, 100 mmf	K11730-G9
C132	Fixed, Ceramic Disc, .005 mfd, 1000 W. V. D. C.	M23034-10
C134	Fixed, Silver - Dur Mica DM-15, 2 mmf, 500 W. V. D. C.	K23006-37
C138	Fixed, Ceramic Temp. Comp. 47N750	K23061-26J
C140	Fixed, electrolytic, 20 mfd, 25 W. V. D. C.	K23091-1
C142	Fixed, Ceramic Disc, Temp. Comp. 440N750	K23010-27
C144, C145, C146 C147, C148, C149	Variable, Cylindrical Trimmer, 1-8 mmf	K23008-2
C150	Fixed, Ceramic Disc, Temp. Comp. 110N750	K23010-5
C151	Fixed, Ceramic Disc, Temp. Comp. 500N1500	K23010-29
C156	Variable, Vernier Tuning 24uuf	K42187-G1

SPECIAL ASSEMBLIES

	Crystal panel, clock window	M38877-1
CMC	Clock, Telechron auto-timer (60 cycle operation)	K38874-G2
CMC	Clock, Telechron auto-timer (50 cycle operation)	K38874-G3
M1	Meter "S" (carrier level)	K-26149-5
Y1	Quartz crystal, 2.580 Mcs	K38972-2
Y2	Quartz crystal, 100.0 Kcs	K38661-1
Y3	Crystal 3035 Kcs	K26481-1
Z1	RC printed network (Calibrator)	K38981-1
Z2	RC printed network (Audio)	K38846-1

SCHEMATIC
DESIGNATION

DESCRIPTION

HAMMARLUND
PART NO.

COILS

L1, L9, L10	RF Choke, 2.5 millihenry	K15627-1
L2	Bifilar Coil	K42032-1
L3	Slot Filter Coil	K42034-1
L4	Passband Tuning Coil	K26301-1
L5, L7, L8	RF Choke, 330 millihenries	K42019-1
L6	Filter Choke, 8.0 henries	K26302-1

RESISTORS

R1, R16, R41, R82, R95	10K ohms, 1/2 w., 10%	K19309-73
R2, R9, R12,	1K ohms, 1/2 w., 10%	K19309-49
R17, R47, R62, R99		
R3, R57	6.8K ohms, 1/2 w., 10%	K19309-69
R4	10 ohms, 1/2 w., 10%	K19309-1
R5, R14, R80	180 ohms, 1/2 w., 5%	K19309-260
R6	Variable, 1.5K ohms, dual with R15 and S3	K38940-1
R7, R42, R49, R65, R70	47K ohms, 1/2 w., 10%	K19309-89
R72, R73, R75, R84, R100		
R8	160 ohms, 1/2 w., 5%	K19309-199
R10, R13, R18, R27, R36	100K ohms, 1/2 w., 10%	K19309-97
R40, R51, R74, R106, R107		
R11, R29, R97, R101	22K ohms, 1/2 w., 10%	K19309-61
R15	Variable, 10K ohms, part of R6	
R19	Variable, 1.5K ohms, meter sens. adj.	K15379-2
R20	Variable, 300 ohms, meter zero adj.	K15379-1
R21	22K ohms, 1 w., 10%	K19310-81
R22	820 ohms, 1/2 w., 5%	K19309-266
R23, R44	1 megohm, 1/2 w., 10%	K19309-121
R24	120 ohms, 1/2 w., 5%	K19309-258
R25	39 ohms, 1/2 w., 5%	K19309-253
R26	Variable, 200 ohms, slot depth	K15368-7
R28, R43, R45,	220K ohms, 1/2 w., 10%	K19309-105
R48, R68, R71		
R30, R32, R37, R46, R76	470K ohms, 1/2 w., 10%	K19309-113
R85, R91, R93, R104		
R31, R33	68 ohms, 1/2 w., 10%	K19309-21
R34	560 ohms, 1/2 w., 10%	K19309-43
R35	1K ohms, 1w., 10%	K19310-49
R39	820 ohms, 1/2 w., 10%	K19309-47
R50	20 ohms, 1/2 w., 5%	K19309-188
R52	10 ohms, 1/2 w., 5%	K19309-246
R53	2K ohms, 10 w., 10%	K19337-5
R54	680 ohms, 1/2 w., 10%	K19309-45
R55	3K ohms, 1/2 w., 5%	K19309-212
R56	15K ohms, 1/2 w., 10%	K19309-77
R58	27K ohms, 2 w., 10%	K19304-52

SCHEMATIC
DESIGNATION

DESCRIPTION

HAMMARLUND
PART NO.

R59, R63, R69	2.2K ohms, 1/2 w., 10%	K19309-57
R60, R61, R66, R67	330K, ohms, 1/2 w., 10%	K19309-109
R65	270 ohms, 1/2 w., 10%	K19309-35
R77	27 ohms, 1/2 w., 10%	K19309-11
R78	Variable, 500K ohms, limiter includes 61	K15378-3
R79	Variable, 1 megohm, audio gain	K26218-3
R81	1.5K, 1 w., 10%	K19310-53
R83	4.7 megohm, 1/2 w., 10%	K19309-137
R86	430 ohms, 1 w., 5%	K19310-212
R87, R98	470 ohms, 1/2 w., 10%	K19309-41
R88	2.7K ohms, 1/2 w., 5%	K19309-272
R89	6.2K ohms, 1/2 w., 5%	K19309-176
R90	3.6K ohms, 1/2 w., 5%	K19309-179
R92	5.6K ohms, 1/2 w., 10%	K19309-67
R94	68 ohms, 1/2 w., 5%	K19309-256
R96	4.7K ohms, 1/2 w., 10%	K19309-65
R102	2.2 megohm, 1/2 w., 10%	K19309-129
R103	13K ohms, 1 w., 10%	K19310-227
R105	11K ohms, 1/2 w., 5%	K19309-215

SWITCHES

S1	Noise Limiter ON-OFF (Part of R78)	
S2A	Switch Wafer, Ant. primary	K26472-3
S2B, C	Switch Wafer, Ant. sec. mixer grid	K26472-2
S2D	Switch Wafer, RF Plate	K26472-1
S2E, S2F, S2G	HF Oscillator Switch Assembly	K26480-1
S3	AC ON-OFF (Part of R6 and R15)	
S4	Send-Receive-Calibrate	K26452-1
S5	Selectivity	K26296-1
S6	Sideband	K26303-1
S7	AM-SSB/CW	K42037-2
S8	AVC	K26309-2

TRANSFORMERS

T1	Transformer, Mixer Plate 3035 and 455 KC	K26474-2
T2	IF Transformer, Crystal Grid	K26473-1
T3	IF Transformer, 355 Kcs	K38829-2
T4, T5	IF Transformer, 455 Kcs	K38946-1
T6, T7, T8, T9	IF Transformer, 60 KCS	K42005-1
T10, T11		
T12	Antenna Transformer, .54 to 1.05 Mcs	K26455-1
T13	Antenna Transformer, 1.05 to 2.05 Mcs	K26456-1
T14	Antenna Transformer, 2.05 to 4.04 Mcs	K26457-1
T15	Antenna Transformer, 4.0 to 7.85 Mcs	K26458-1
T16	Antenna Transformer, 7.85 to 15.35 Mcs	K26459-1

SCHEMATIC
DESIGNATION

DESCRIPTION

HAMMARLUND
PART NO.

T17	Antenna Transformer, 15.35 to 30 Mcs	K26460-1
T19	RF Transformer, .54-1.05 and 1.05-2.05 mcs	K26461-1
T20	RF Transformer, 2.05-4.04 and 4.0-7.85 mcs	K26462-1
T21	RF Transformer, 7.85-15.35 and 15.35-30 mcs	K26463-1
T23	Osc Coils .54 to 1.05 and 1.05 to 2.05 mcs	K26464-1
T24	Osc Coil 2.05 to 4.04 Mcs	K26465-1
T25	Osc Coil 4.0 to 7.85 mcs	K26466-1
T26	Osc Coil 7.85 to 15.35 mcs	K26467-1
T27	Osc Coil 15.35 to 30 mcs	K26468-1
T28	BPO Transformer, 60 Kcs	K42005-4
T29	Audio Output Transformer	K38828-1
T30	Power Transformer 117 V.A.C.	P26305-1
T30E	Power Transformer 115-230 V Export Model	P26305-2

MISCELLANEOUS

E1	Fuse, holder	K15923-1
F1	Fuse, 3 Amp. type 3 AGC	K15928-8
I1, I2, I3	Lamp, pilot No. 47, 6.3 V. .15A	K16004-1
J1	External Relay Receptacle	K35013-1
J2	Phone Jack	K35608-1
J3	Antenna Connector, SO-239	K16111-1

OPTIONAL ACCESSORIES

Telechron Clock Assembly Conversion
Kits including instructions for converting
model HQ-180 to Model HQ-180C are listed
as follows:

24 Hour Clock Kit (115V/230V - 50 cycles)	PL26380-G3
24 Hour Clock Kit (115V/230V - 60 cycles)	PL26380-G4
Loudspeaker assembly in cabinet matched to the Models HQ-180, HQ-180C and HQ-180E	PL26394-G1

ADDENDA TO PARTS LIST
FOR HQ-180XE

<u>SCHEMATIC DESIGNATION</u>	<u>DESCRIPTION</u>	<u>HAMMARLUND PART NO.</u>
C158	Cap Fixed, Electrolytic, 200 mfd, 25V DC NP	K23925-1
C159	Cap Fixed, Dur-Mica DM-15, 25 mmf ± 5%, 500V	K23006-142
C160	Cap Fixed, Ceramic Disc, .005 mfd -80 - 20%, 500V	M23034-37
CR1	Diode, Silicon (in 1490)	K41212-1
K1	Relay, Amps	K40404-1
R108	Res. 100K ohms, 1/2 w., ± 10%	K19309-97
R109	Res. 62K ohms, 1/2 w., ± 5%	K19309-183
R110	Res. 16K ohms, 1/2 w., ± 5%	K19309-217
R111	Res. 22 ohms, 1 w., ± 10%	K19310-9
S9	Switch, Crystal Selector	K39145-1

ADDENDA TO PARTS LIST
FOR HQ-180A

<u>SCHEMATIC DESIGNATION</u>	<u>DESCRIPTION</u>	<u>HAMMARLUND PART NO.</u>
CR2, CR3	Rectifier, Silicon (CER72C) 800 PIV, 255	M41215-3
F1	Fuse, 1-1/2 Amp Type 3 AGC for 50-60 Cycles 230V operation	K15928-6
J1	Socket (8 pin) (System Socket)	K16083-1
J4	Connector Female (Accessory Socket)	K41138-1
S2E, F, G	HF Oscillator Switch Assem.	K26480-1
S7	Switch (AM-SSB-CW)	K52033-1
T18	Power Transformer	P26305-4
T22	Filament Transformer	K39224-2
T29	Output Transformer	K38828-2
C161	Capacitor, Fixed, Dur-Mica DM-15, 47 mmf, 300V	K23006-47

ADDENDA TO PARTS LIST
FOR HQ-180AX

<u>SCHEMATIC DESIGNATION</u>	<u>DESCRIPTION</u>	<u>HAMMARLUND PART NO.</u>
CR2, CR3	Rectifier, Silicon (CER72C) 800 PIV, 255	M41215-3
F1	Fuse 1-1/2 Amp Type 3 AGC for 50-60 Cycles 230V Operation	K15928-6
J1	Socket (8 pin) (System Socket)	K16083-1
J4	Connector Female (Accessory Socket)	K41138-1
S2E, F, G	HF Oscillator Switch Assem.	K26480-1
S7	Switch (AM-SSB-CW)	K52033-1
T18	Power Transformer	P26305-4
T22	Filament Transformer	K39224-2
T29	Output Transformer	K38828-2
C161	Capacitor, Fixed, Dur-Mica DM-15, 47 mmf, 300V	K23006-47

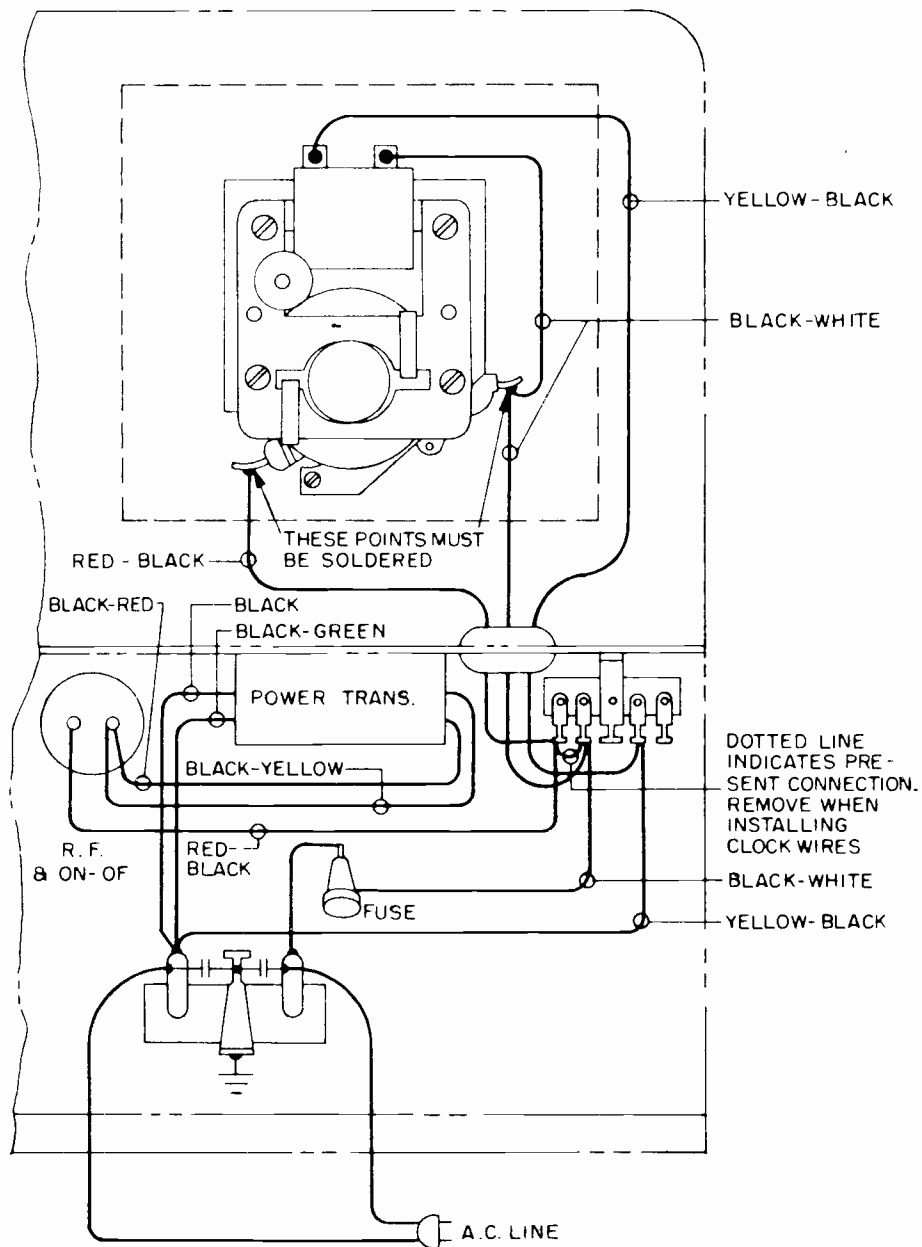

CLOCK INSTALLATION HQ-170 & HQ-180
 115V 50 OR 60~

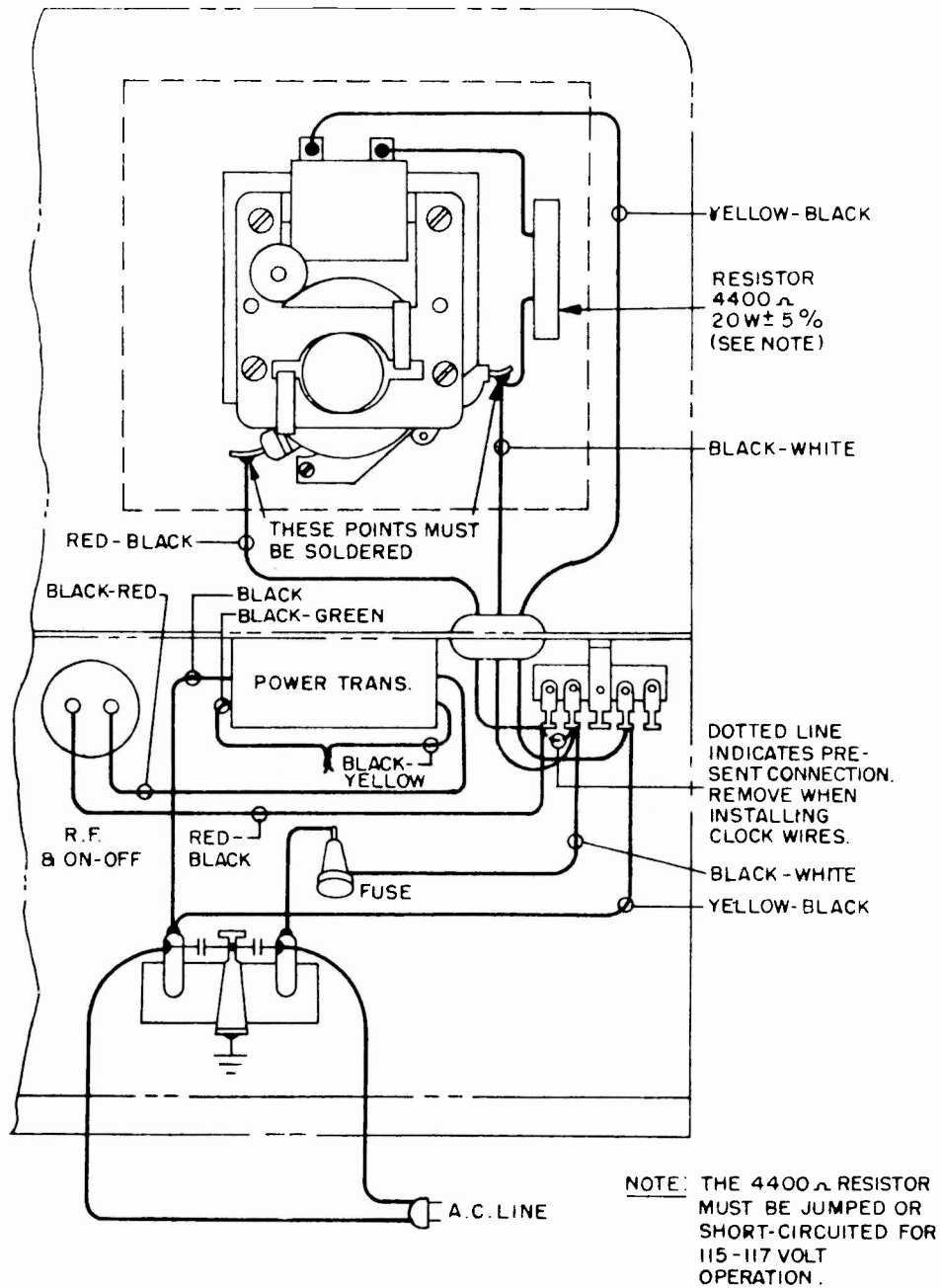

**CLOCK INSTALLATION HQ-170 & HQ-180
230V 50 OR 60 \sim**

HX-50 TRANSMITTER

HQ-180A RECEIVER

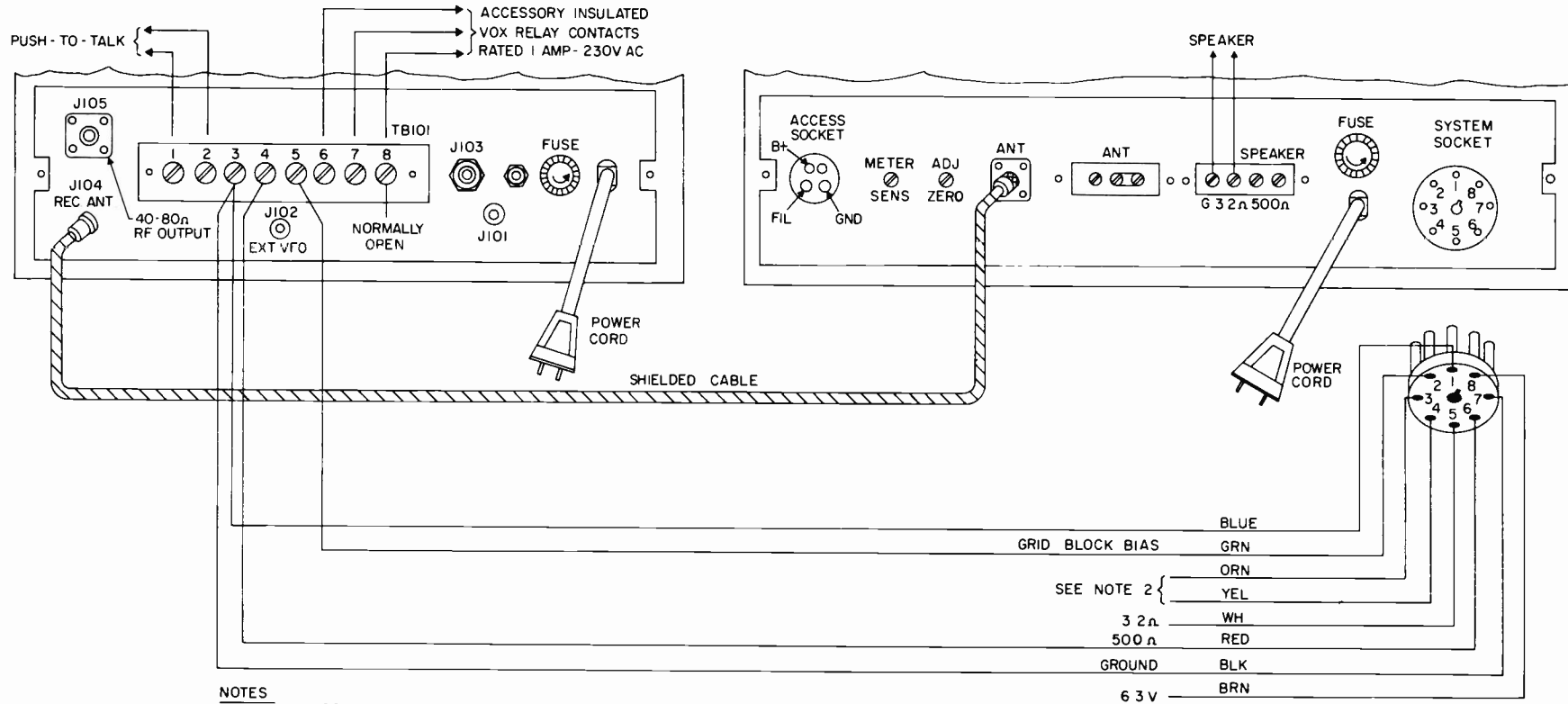

NOTES

1. HOOK-UP SHOWN IS USING GRID BLOCK BIAS TO THE HQ-180-AX
2. IF RELAY SWITCHING IS DESIRED
 - a. DISCONNECT GRID BLOCK BIAS (GREEN LEAD) FROM PIN 5 OF TB101
 - b. WIRE ORANGE LEAD TO PIN 7 AND YELLOW LEAD TO PIN 6
3. IF GRID BLOCK BIAS IS USED, RELAY CONTACTS PINS 6 & 7 ON HX-50 MAY BE USED FOR OTHER FUNCTIONS THESE ARE NORMALLY CLOSED
4. WHEN USING VOX CONTROL OF THE HX-50 TRANSMITTER, PIN NO. 1 OF THE HQ-180A OR HQ-180AX RECEIVERS SYSTEM SOCKET SHOULD BE CONNECTED TO PIN NO. 3 OF HX-50 TERMINAL BOARD AS SHOWN IN DIAGRAM

SUGGESTED INTERCONNECTIONS
(HX-50 HQ-180-AX)

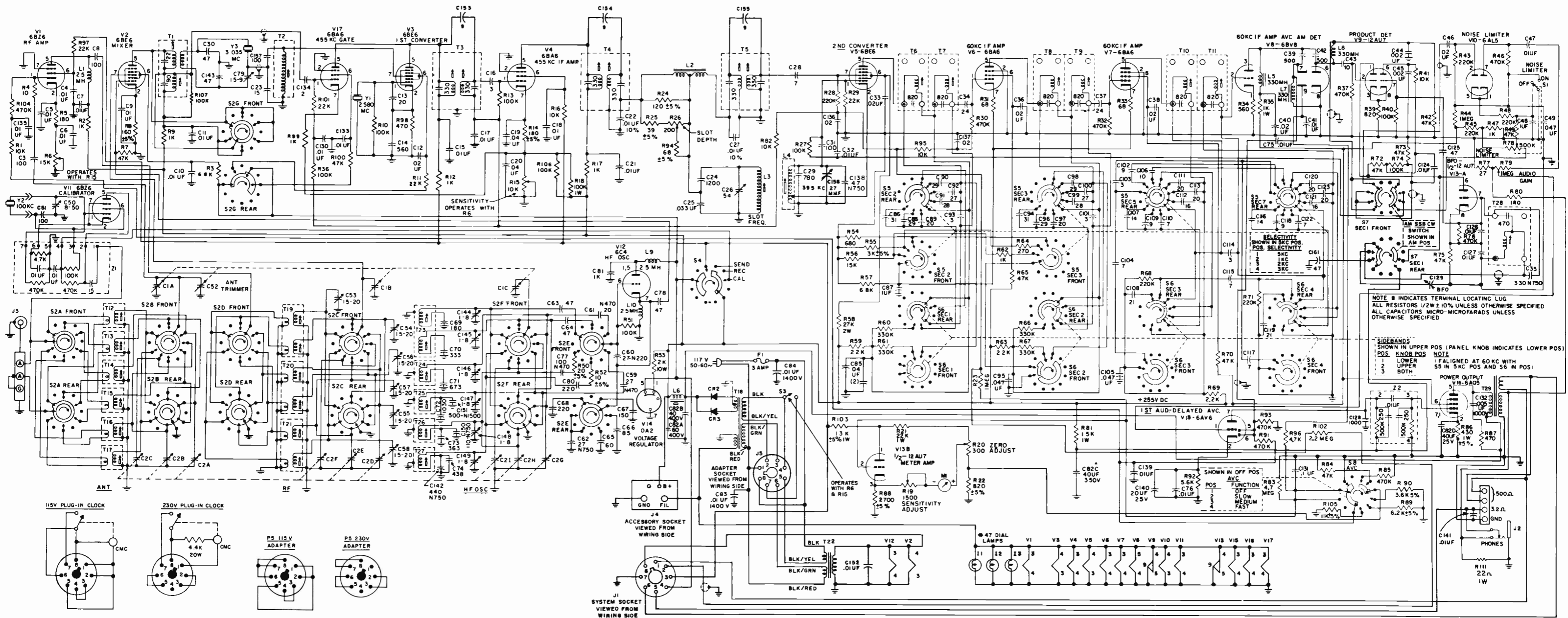

SCHMATIC DIAGRAM, HQ-180A

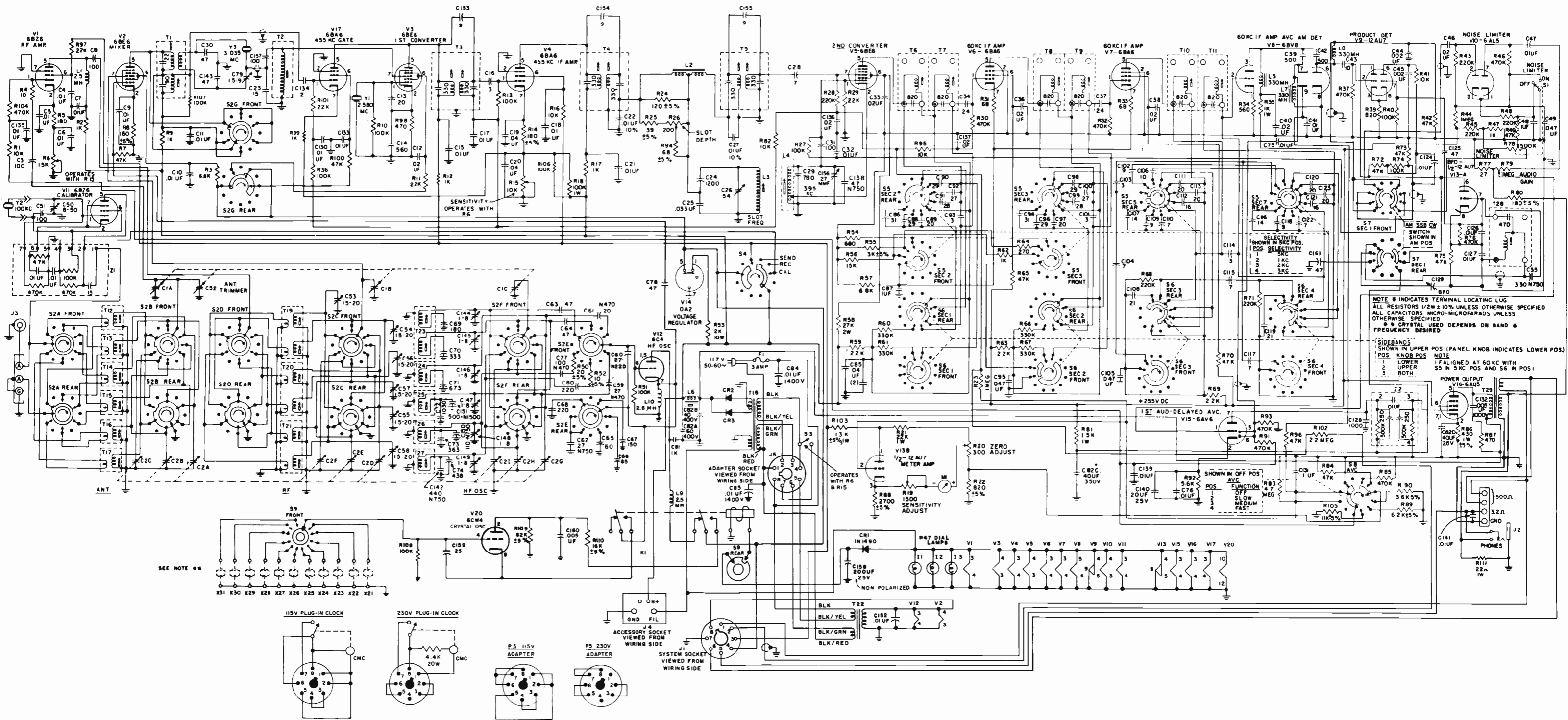

SCHEMATIC DIAGRAM, HQ-180AX

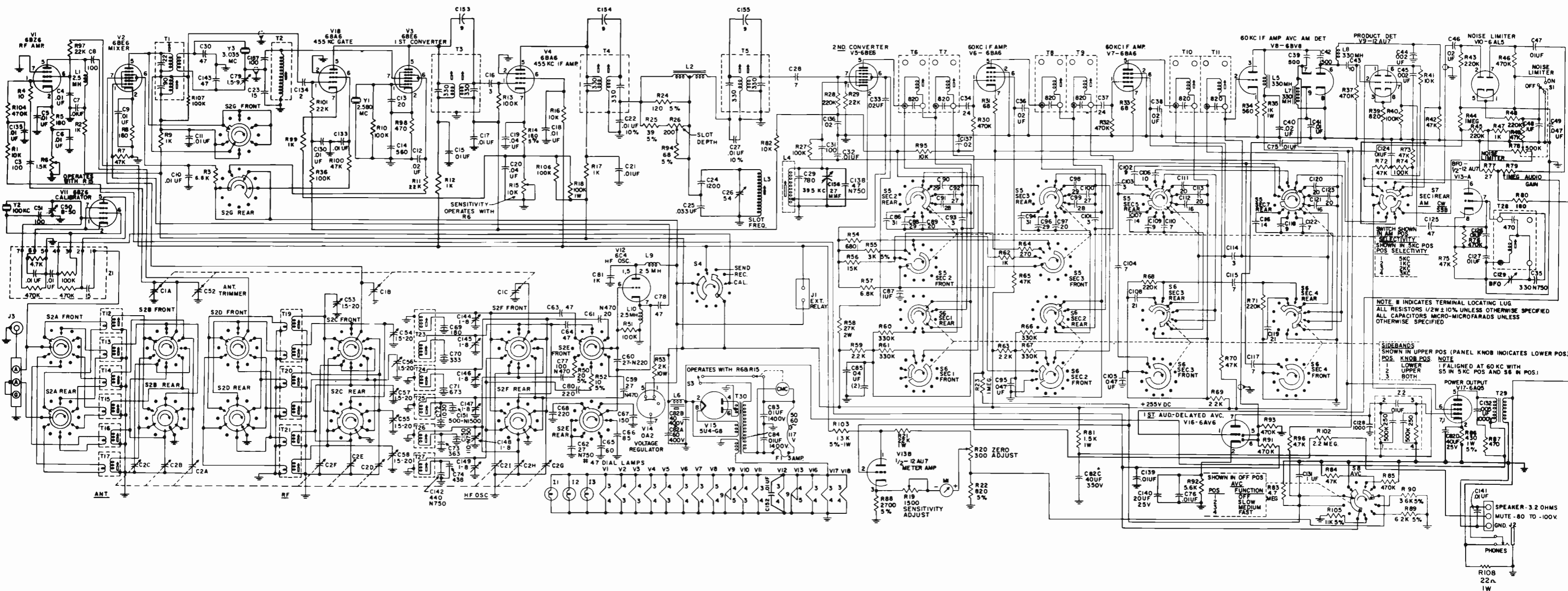

SCHMATIC DIAGRAM, HQ-180

ADDENDUM
TO
TECHNICAL DESCRIPTION AND OPERATING INSTRUCTION MANUAL NO. 52787-1
HQ-180 SERIES COMMUNICATIONS RECEIVERS

Page 8 and Page 26

Change Crystal Frequency Chart to read as follows:

<u>SIGNAL FREQUENCY</u> <u>Range mc</u>	<u>ADD IF----</u> <u>Frequency mc</u>	<u>SUBSTRACT IF----</u> <u>Frequency mc</u>	<u>MODE OF</u> <u>OPERATION</u>
1.80 to 2.05	.455000		Fundamental
2.05 to 4.0	.455000		Fundamental
4.0 to 7.85	.455000		Fundamental
7.85 to 15.35	3.035		Fundamental
15.35 to 20.662	3.035		Fundamental
20.662 to 30.0		3.035	2nd Harmonic

Page 30

Make the following change to the Detector, BFO and Noise Limiter Circuit Diagram:

1. Capacitor C124 was connected from junction of R73 and R74 to junction of R72 and R74. This capacitor (C124) is now connected from junction of R72 and R74 to ground.

CHANGES TO HQ-180A SCHEMATIC DIAGRAM

1. Change resistor R3 from 6.8K $\pm 10\%$, 1/2W to 6.8K $\pm 10\%$, 1W.
2. Change resistor R19 from 1.5K $\pm 10\%$, 1/2W to 1.5K $\pm 30\%$, 1/2W.
3. Change resistor R20 from 300 $\Omega \pm 10\%$, 1/2W to 1.5K $\pm 30\%$, 1/2W.
4. Change resistor R22 from 820 $\Omega \pm 5\%$, 1/2W to 470 $\Omega \pm 10\%$, 1/2W.
5. Change resistor R33 from 68 Ω 1/2W to 390 $\Omega \pm 5\%$, 1/2W.
6. Change resistor R47 from 1K $\pm 10\%$ to 2.2K $\pm 10\%$.
7. Change resistor R53 from 2K 10W, to 4K $\pm 10\%$, 10W.
8. Change resistor R61 from 330K Ω , 1/2W to 820K Ω , 1/2W.
9. Change resistor R67 from 330K Ω , 1/2W to 820K Ω , 1/2W.
10. Change resistor R88 from 2700 $\Omega \pm 5\%$, 1/2W to 2.7K $\pm 10\%$, 1/2W.
11. Change resistor R99 from 1K $\pm 10\%$, 1/2W to 2.2K $\pm 10\%$, 1/2W.
12. Delete capacitor C6 .01 mf.
13. Add capacitor C158 .01 mf, from pin 7 of V17 (6BA6) to ground.

CHANGES TO PARTS LIST

Page 67

HAMMARLUND
PART NO.

1. Delete capacitor C6 .01 mf 600V.

1509-01-01011

Page 68

1. Add capacitor C158 .01 mf 600V.

1509-01-01011

Page 69

1. Change resistor R3 to read 6.8K $\pm 10\%$, 1W. 4704-01-00642
2. Change resistor R19 to read Variable, Meter Sens. Adj.,
1.5K $\pm 30\%$, 1/2W. 4735-01-00404
3. Change resistor R20 to read 1.5K $\pm 30\%$, 1/2W. 4735-01-00404
4. Change resistor R22 to read 470 $\Omega \pm 10\%$, 1/2W. 4703-01-00328
5. Change resistor R33 to read 390 $\Omega \pm 5\%$, 1/2W. 4703-02-00437
6. Change resistor R47 to read 2.2K $\pm 10\%$, 1/2W. 4703-01-00336
7. Change resistor R53 to read 4K $\Omega \pm 10\%$, 10W. 4714-01-01002
8. Change resistor R99 to read 2.2K $\pm 10\%$, 1/2W. 4703-01-00336

Page 70

1. Change resistor R88 to read 2.7K $\pm 10\%$, 1/2W. 4703-01-00337
2. Change resistor R61 to read 820K Ω , $\pm 10\%$, 1/2W. 4703-01-00367
3. Change resistor R67 to read 820K Ω , $\pm 10\%$, 1/2W. 4703-01-00367

It has been found on the HQ-180A Series Communications Receivers that the tubes will have longer life with the tube shields removed. Therefore, the tube shields on tubes V1, V4, V6, V7, V10, V16 and V18 have been eliminated.

Also, after extensive environmental testing, it was found that under certain conditions the plastic dust covers for the main tuning and bandspread capacitors served very little useful purpose and in some cases caused system degradation. These dust covers and tube shields have been eliminated on all present and future production runs of the HQ-180A Series Communications Receivers and do not appear on the receiver as shown in the illustration of the top view of the chassis in the present manual.

Starting with the present production units, the clock installation drawings on Page 73 and 74 are no longer required. The clock is now furnished with a pre-wired program plug as shown on the HQ-180A Schematic diagram.



THE HAMMARLUND MANUFACTURING COMPANY
Standard Warranty

The Hammarlund Manufacturing Company, warrants this equipment to be free from defects in workmanship and materials under normal and proper use and service for the uses and purposes for which it is designed, and agrees to repair or replace, without charge, all parts thereof showing such defects which are returned for inspection to the Company's factory, transportation prepaid, within a period of 90 days from date of delivery, provided such inspection discloses to the satisfaction of the Company that the defects are as claimed, and provided also, that the equipment has not been altered, repaired, subjected to misuse, negligence or accident, or damaged by lightning, excessive current or otherwise, or had its serial number or any part thereof altered, defaced, or removed. Tubes shall be deemed to be covered by the manufacturer's standard warranty applicable thereto, and such items shall be and are hereby excluded from the provisions of this warranty. Pilot lamps and fuses are not guaranteed for length of service.

Except as herein specifically provided, no warranty, express or implied, other than that of title, shall apply to any equipment sold hereunder. In no event shall the Company be liable for damages by reason of the failure of the equipment to function properly or for any consequential damages.

This Warranty is valid for the original owner of the equipment, and is contingent upon receipt of the Warranty Registration Card by the Company. No equipment shall be returned to the factory for repairs under warranty unless written authorization is obtained by the Company, and the equipment is shipped prepaid by the owner. The Company maintains Authorized Service Stations, names and locations of which will be sent upon request of the owner.

HAMMARLUND MANUFACTURING COMPANY, INC.
A Giannini Scientific Co.
73-88 Hammarlund Drive, Mars Hill, North Carolina
Export Department: 13 East 40th Street, New York 16, N. Y.

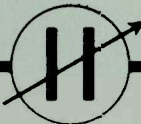

The policy of the Hammarlund Manufacturing Company, is one of continued improvement in design and manufacture wherever and whenever possible, to provide the highest attainable quality and performance. Hence, specifications, finishes, etc. are subject to change without notice and without assumption by Hammarlund of any obligation or responsibility to provide such features as may be changed, added or dropped from previous production runs of this equipment.

DO NOT MAKE ANY RETURNS WITHOUT AUTHORIZATION FROM EITHER NEW YORK OFFICE OR FACTORY. ALL AUTHORIZED RETURNS SHOULD BE SHIPPED TO FACTORY, HAMMARLUND MANUFACTURING CO., MARS HILL, NORTH CAROLINA. DO NOT SHIP TO NEW YORK OFFICE.



®

ESTABLISHED 1910