

# THE HQ-200 COMMUNICATIONS RECEIVER

INSTRUCTION AND SERVICE INFORMATION



ESTABLISHED 1910

9001-06-00015

ISSUE 1

NOV., 1968

THE HAMMARLUND MANUFACTURING COMPANY INCORPORATED

73-88 Hammarlund Drive : : Mars Hill, North Carolina

ADDENDUM  
TO  
COMMUNICATIONS RECEIVER MANUAL  
HQ-200, P/N 9001-06-00015, ISSUE 1

Modification to parts list

Page 22,

Was:	C1, A,B,C	Variable, Main Tuning	9441-60-40003
Is:	C1, A,B,C	Variable, Main Tuning	9441-60-40012
Was:	C2, A,B,C,D	Variable, Bandsread	9441-60-40007
Is:	C2, A,B,C,D	Variable, Bandsread	9441-60-40014
Was:	R2	Potentiometer, 10,000 ohms	4735-02-00001
Is:	R2	Potentiometer, 10K	4735-01-16002
Add:	R7	Potentiometer, 25k	Part of R2

Page 23,

Was:		Knob, 1½ Diameter	2430-01-00062
Is:		Knob, 1.758 Diameter	2430-02-00127
Was:		Knob, 7/8 Diameter	2430-01-00060
Is:		Knob, .908 Diameter	2430-02-00128
Was:		Knob, 11/16 Diameter	2430-02-00061
Is:		Knob, .704 Diameter	2430-02-00129
Was:	R20	Resistor, 10,000 ohms, 5W	4713-01-00015
Is:	R20	Resistor, 15,000 ohms, 5W	4713-01-00017

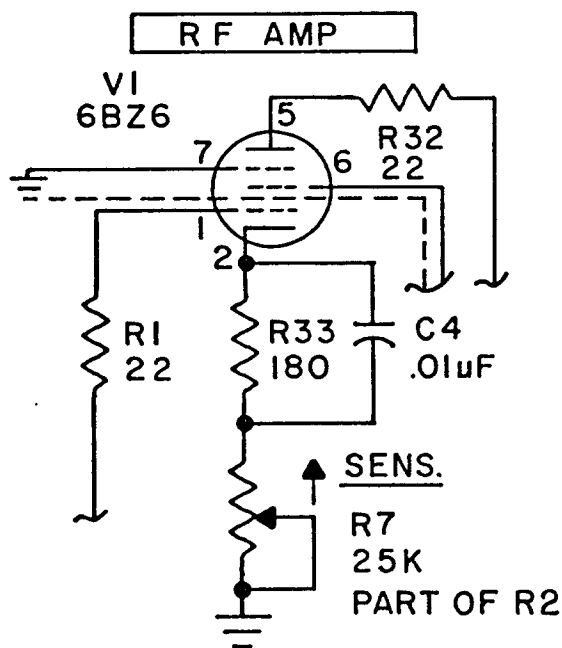

7 FEB 1973

P/N 9001-15-00005  
June, 1970

TABLE OF CONTENTS

<u>SECTION</u>	<u>TITLE</u>	<u>PAGE</u>	<u>SECTION</u>	<u>TITLE</u>	<u>PAGE</u>
	HQ-200 Specifications	II	4.4	Resistance Measurements	19
	Introduction	III	4.5	IF Alignment	19
			4.6	RF Alignment	21
			4.7	Dial Calibration	21
1	<u>INSTALLATION</u>	1			
1.1	Unpacking	1	5	<u>PARTS LIST</u>	22
1.2	Receiver Connections	1			
2	<u>OPERATION</u>	4	6	<u>SCHEMATIC DIAGRAM</u>	25
2.1	General	4			
2.2	Operation of Controls	4			
2.3	Tuning AM Signals	9			
2.4	Tuning CW Signals	9			
2.5	Tuning SSB Signals	10			
2.6	Where to Listen	10			
				<u>LIST OF ILLUSTRATIONS AND TABLES</u>	
			<u>FIGURE</u>	<u>TITLE</u>	<u>PAGE</u>
			1-1	Rear Connections	2
			1-2	Typical Antenna Installation	2
			1-3	Installation of Earth Ground	3
			1-4	Typical Lightning Arrestor Installation	3
			2-1	HQ-200 Front View	5
			2-2	Use of Bandsread Logging Scale	7
			3-1	IF Selectivity	15
			4-1	Tube Location	18
			4-2	HQ-200 Top View	20
			4-3	HQ-200 Bottom View	20
			6-1	HQ-200 Schematic Diagram	25
3	<u>THEORY OF OPERATION</u>	13			
3.1	General	13			
3.2	RF Amplifier and High Frequency Oscillator	13			
3.3	Mixer and IF Amplifiers	13			
3.4	Q-Multiplier	13			
3.5	AVC and "S" Meter	14			
3.6	Product Detector and BFO	14			
3.7	Noise Limiter and Audio Amplifiers	14			
3.8	Power Supply	14			
4	<u>ALIGNMENT AND SERVICE</u>	16	<u>TABLE</u>	<u>TITLE</u>	<u>PAGE</u>
4.1	General	16	4-1	Tube Socket Voltages	17
4.2	Trouble Analysis	16	4-2	Tube Socket Resistance	17
4.3	Voltage Measurements	16			

# HQ-200 SPECIFICATIONS

FREQUENCY RANGE.....	540 kHz to 30 MHz in four bands.			
CALIBRATED BANDSPREAD.....	Dial markings every 10 kHz on 80, 40, and 20 meter bands; every 20 kHz on 15 meter band; every 50 kHz on 10 meter band. Plus 0-100 arbitrary logging scale.			
MAXIMUM AUDIO OUTPUT.....	1.0 Watt (Undistorted)			
OUTPUT IMPEDANCE.....	3.2 ohms (EIA standard)			
AVC ACTION.....	Operates on RF and IF stages. Provides fast, smooth action.			
VARIABLE SELECTIVITY.....	One position for high quality broadcast. One position for Q-Multiplier continuously variable from 100 Hertz to 3 kHz.			
SENSITIVITY.....	AM	2.5 microvolt or less produces 10-1 signal-to-noise ratio		
	CW/SSB	0.5 microvolt or less produces 10-1 signal-to-noise ratio		
ANTENNA INPUT.....	100 ohms nominal (50-600 ohm)			
ANTENNA COMPENSATOR.....	Permits compensation for loading effects of various type antennas, or balanced transmission line.			
BEAT FREQUENCY OSCILLATOR.....	Variable from zero beat to $\pm 2$ kHz			
POWER SUPPLY.....	117/230V AC, 50-60 Hertz, 50 Watts			
"S" METER.....	Calibrated 1 to 9 in steps approximately 6 db. Also includes db scale above S-9 to + 60 db.			
NOISE LIMITER.....	Shunt type which provides better limiting action with minimum effect on modulation.			
TUBE COMPLEMENT.....	RF Amplifier	6B26	First AF Amplifier	12AX7 ( $\frac{1}{2}$ )
	Mixer	6BE6	Q-Multiplier	12AX7 ( $\frac{1}{2}$ )
	HF Oscillator	6C4	Audio Power Output	6AQ5
	1st IF Amplifier	6BA6	Voltage Regulator	Zener Diode
	2nd IF Amplifier	6BA6	Rectifier	CER72C (2)
	Product Detector	6BE6	Noise Limiter	1N541A
	AM Detector	1N34A		
FRONT PANEL EQUIPMENT.....	Main Tuning		Limiters On-Off Switch	Selectivity OFF
	Bandspread		"S" Meter	LSB-BFO-USB
	Sensitivity (RF Gain)		Q-Multiplier Freq.	
	Audio Gain			
	Antenna (Compensator)		AVC-MAN- Switch	
Tuning Range (Selector)		OFF-AM-SEND-CW/SSB		
REAR PANEL EQUIPMENT.....	Terminal for speaker connections		Phone Jack	
	Terminal for antenna and ground connections		"S" Meter zero	
DIMENSIONS.....	17" WIDE, 9" HIGH, 9 1/8" DEEP			
	Weight: 22 lbs.			
	Shipping Wt.: 26 lbs.			
	Specifications subject to change without notice.			

## INTRODUCTION

The Hammarlund HQ-200 is an all new communications receiver representing Hammarlund's never-ending search to improve receiver performance. The HQ-200 will provide the discriminating amateur or short wave listener years of top performance with minimum maintenance. The HQ-200 receiver has a self-contained solid state power supply and a universal transformer capable of operation from a 117 volt or 230 volt 50/60 Hertz source.

The HQ-200 is a superheterodyne receiver with a frequency coverage continuously tunable from 540 kHz to 30 MHz with extremely fine control in separation of crowded signals. A very high signal-to-noise ratio plus the noise limiter circuit, permits full use of the receiver's excellent sensitivity on the weakest signals. A Q-Multiplier is provided for varying the selectivity of the receiver while the electrical bandspread provides accurate tuning in the most crowded portions of the radio spectrum.

Electrical bandspread tuning is provided with direct calibration every 10 kHz on 80, 40 and 20 meter bands; every 20 kHz on the 15 meter band and every 50 kHz on the 10 meter band. In addition, an arbitrary bandspread logging scale is provided for use throughout the tuning range of the receiver. CB channels are also indicated on the bandspread logging scale. The main dial is marked to indicate the location of the majority of the international short wave stations. The red segments on the main dial indicate the location of international short wave stations on 60, 49, 41, 31, 25, 19, 16, 13 and 12 meters as well as many more to numerous to mention.

The HQ-200 is equipped with a product detector and a stable beat frequency oscillator which provides the operator with a continuous range of audio tones when receiving telegraph code signals, or excellent single-side band reception.

An "S" meter is provided to obtain accurate readings on received phone signals and to assure "on-the-nose" tuning. Fast acting AVC maintains a constant audio level. The receiver may be used with either speaker or headphones. A send-receive switch is provided to silence the receiver while transmitting.

The HQ-200 was designed with you in mind. The logical grouping of the large, comfortable controls are located to permit the greatest operating ease. The front panel is clearly marked to permit full attention to the operating at hand.

The Hammarlund HQ-200 Communications Receiver is a unique radio whose concept was designed with the operator in mind. You will have many hours of pleasure in operating this truly fine communications instrument.

## SECTION 1 INSTALLATION

### 1.1 UNPACKING

Immediately after receipt of the receiver it should be removed from the shipping carton and visually inspected to insure that it has not been damaged in shipment. If it is determined that the receiver has been damaged in transit the shipping carton and packing material should be saved and the transportation company notified immediately.

As part of the initial inspection all of the front panel controls should be checked to insure their proper mechanical operation. It is advisable to generally, "look the receiver over" and verify that nothing has been shaken loose and that everything appears to be normal.

The following items are supplied with each receiver:

1. Instruction manual, Hammarlund part number 9001-06-00015, quantity 1.

### 1.2 RECEIVER CONNECTIONS

If the HQ-200 Receiver is to be used for receiving only and not as part of a system with interconnections to an associated transmitter there are only a few required connections. These connections are easily accessible at the rear of the receiver and their design permits permanent connections to be made in a neat manner. Figure 1-1 illustrates the connections points at the rear of the receiver.

#### 1.2.1 ANTENNA CONNECTION

The HQ-200 is designed to operate with a single wire or a balanced type antenna. The front panel antenna trimmer control permits a good match to most antennae systems of 50 to 600 ohms.

For general coverage, single wire antennae of 20 to 50 feet length will provide surprisingly good reception. A long

single wire outdoor antenna, such as shown in Figure 1-2 will generally provide entirely satisfactory performance. This wire may be 50 to 150 feet long.

For best reception, the antenna should be isolated as much as possible from neighboring objects and at right angles to power lines or busy highways so as to minimize possible interference pickup.

Optimum performance on a particular amateur band or other narrow tuning range will be obtained by using a tuned half-wave dipole or folded dipole fed with 300 ohm transmission line or other suitable lead-in, as shown in Figure 1-2.

To tune the one-half wave length dipole, the following formula for the length of the antenna may be used:

$$\text{Length (feet)} = \frac{468}{\text{Freq. (MHz)}}$$

Each half (1/4 wave length) is half the length found from the above formula.

A good ground will generally aid in reception and reduce stray line hum. Reversal of polarity of power cord plug may possibly further reduce line hum in some locations.

To obtain the best results from the receiver the antenna that most nearly suits your needs should be selected. The illustrations shown in Figure 1-2 are typical antenna installations.

#### 1.2.2 SPEAKER CONNECTIONS

Connect a 3.2 ohm permanent magnet dynamic speaker (Hammarlund S-100 Speaker) to the two terminals marked SPKR, on the rear of the chassis. (Figure 1-1). For best performance do not place speaker on top of receiver cabinet.

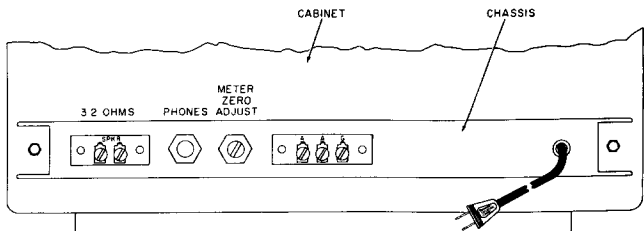
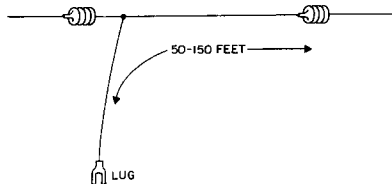
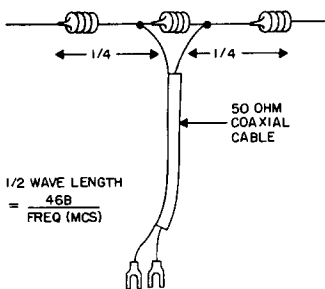
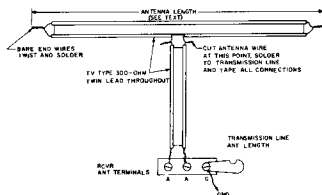

FIGURE I-1. REAR CONNECTIONS.



SINGLE WIRE ANTENNA

← 1/2 WAVE →



DIPOLE ANTENNA

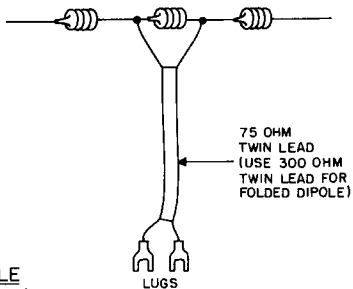

FIGURE I-2. TYPICAL ANTENNA INSTALLATION.

### 1.2.3 GROUND CONNECTIONS and/or LIGHTNING ARRESTOR INSTALLATION

A good external earth ground connection to the chassis is a must to eliminate a potential shock hazard. It is possible that a voltage may exist between the chassis and ground as a result of the two power line by-pass capacitors that are connected across the power line with the center tap grounded. A method of connecting a ground is illustrated in Figure 1-3.

As added protection it is also desirable to install a lightning arrestor. This would provide protection for the receiver as well as the operator. Figure 1-4 illustrates two methods of installing lightning arrestors.

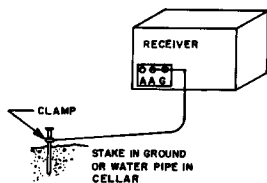

FIGURE 1-3. INSTALLATION OF EARTH GROUND.

### 1.2.4 POWER CONNECTIONS

Before inserting the power cable into a receptacle it should first be determined that the power source is of the proper voltage and frequency.

The HQ-200 is designed to be operated from a standard 110/120 volt, 50/60 Hertz AC supply or, by making internal changes, from a 220/230 volt, 50/60 Hertz AC supply.

As normally shipped from the factory, the receiver is wired to be plugged into a standard 110/120 volt receptacle. For 220/230 volt operation it will be necessary to remove the unit from the case and reconnect the power transformer primary as called for on the schematic. Also, when changing from 110 to 220 volts (or vice versa) be sure to install the proper fuse.

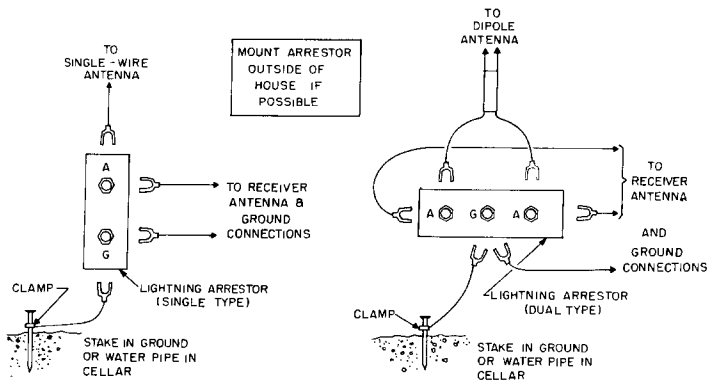

FIGURE 1-4. TYPICAL LIGHTNING ARRESTOR INSTALLATION.



## SECTION 2 OPERATION

### 2.1 GENERAL

With the receiver installed as suggested in Section 1 it is now ready to receive transmissions. This section is intended as an aid to operate the receiver in a manner that will produce the best audible signal possible. A brief description of each of the front panel controls is followed by detailed instructions for tuning AM, CW and SSB signals.

### 2.2 OPERATION OF CONTROLS

The index numbers referred to in this section are taken from Figure 2-1 unless otherwise noted.

#### 2.2.1 FUNCTION SWITCH (Index #1)

The Function Switch of the receiver has four positions, "OFF-AM-SEND-CW/SSB". In the OFF position the switch opens the line to the power transformer thereby all power is removed from the receiver. In the AM position the receiver is turned "ON" and after an appropriate warm up time is ready to receive signals. See detailed instructions below for tuning AM signals. The SEND position of the function switch is used when an associated transmitter is keyed on for transmissions. When this switch is placed in the SEND position voltage is removed from five stages thereby rendering the receiver inoperative. The CW/SSB position is used when copying either of these types of signals. By placing the switch in the CW/SSB position the BFO and product detector are turned ON. See detailed instructions below for tuning CW or SSB signals. The receiver is ready for reception when in either the AM or CW/SSB position. When in the SEND position it is temporarily disabled but can be switched to either AM or CW/SSB and is immediately ready for reception.

#### 2.2.2 ANTENNA TRIMMER CONTROL (Index #2)

The Antenna Trimmer Control is a single section air variable capacitor that tunes

the input to the RF amplifier. An approximate setting for this control would be with the mark on the knob vertical. As the band or frequency is changed when tuning the receiver this control should be peaked. When tuning an AM station (with AVC-ON) the reading on the S-meter should be peaked with this control. When receiving CW or SSB the control will be peaked to produce the strongest signal as heard at the speaker. This control should always be peaked in order for the receiver to provide the optimum in sensitivity.

#### 2.2.3 MAIN TUNING CONTROL (Index #3)

The Main Tuning Control tunes the oscillator, RF and antenna sections to the frequency marked on the main tuning dial (Index #14). This control tunes the band selected by the tuning range switch (Index #6). This control sets the receiver up for the desired frequency to be received. The calibration and use of the dial is explained in Section 2.2.14.

#### 2.2.4 SENSITIVITY CONTROL (Index #4)

The Sensitivity Control manually controls the gain of the receiver. The gain of the receiver is at its maximum when this control is in the maximum clockwise position. This control functions in two stages of the receiver. The gain of the two stages is decreased as the control is rotated in a counterclockwise direction.

#### 2.2.5 MAN-AVC SWITCH (Index #5)

This switch selects either manual (MAN) or automatic volume control (AVC). When in the MAN position the gain of the receiver must be manually controlled by means of the sensitivity control (Index #4). When placed in the AVC position the gain of the receiver is automatically controlled by means of its internal circuitry. It must be noted that the switch should only be placed in the AVC position when the function switch (Index #1) is



FIGURE 2-1. HQ 200 FRONT VIEW.

in the AM position. The gain of the receiver must be manually controlled when receiving CW or SSB signals, therefore; the switch should be in the MAN position when receiving these types of signals.

#### 2.2.6 TUNING RANGE SWITCH (Index #6)

The Tuning Range Switch is a five position switch that selects the particular segment of frequencies to be tuned by the main tuning control (Index #3). The markings around this control indicate the segment of frequencies for each of the bands. The 20 BS position is a special position that permits the 20 meter amateur band to "spread-out" by the bandspread control (Index #9). The calibration of the 14 kHz section of the bandspread dial (Index #13) is accurate only when the band selector switch is in the 20 BS position.

#### 2.2.7 NOISE LIMITER SWITCH (Index #7)

The Noise Limiter control disables the noise limiter in the OFF position and will clip noise pulses when placed in the LIM ON position. The noise limiter should be left in the OFF position when not experiencing ignition noise or some other type of impulse noise. The limiter should be turned on to minimize this type of interference. It may be noted that a slight decrease in audio will be experienced when turning the noise limiter on.

#### 2.2.8 AUDIO GAIN CONTROL (Index #8)

The Audio Gain Control governs the level of audio output from the receiver. The output from the speaker terminals and the phone jack are simultaneously controlled by this control. The output is increased as the control is rotated in a clockwise direction.

#### 2.2.9 ELECTRICAL BANDSPREAD CONTROL (Index #9)

The Electrical Bandsread Control will turn the bandspread dial (Index #13) as it tunes the amateur bands. This

control functions as a vernier to "spread-out" a small portion of the band selected by the main tuning control (Index #3). The use of the bandsread dial and its calibration are explained in Section 2.2.13.

#### 2.2.10 SELECTIVITY CONTROL (Index #10)

The Selectivity Control governs the passband of the receiver. With the selectivity control at its extreme counterclockwise position (OFF) the selectivity or passband of the receiver is at its maximum. With the selectivity of the receiver at its maximum a greater number of signals may be heard for a particular setting of the dials. An example of this would be to tune thru a particular band and notice two signals very close together on the band. It will be noticed that by turning the selectivity control clockwise, and peaking the Q-Multiplier Frequency Control (Index #11) on the desired signal of the two, the undesired signal will decrease as it "falls out" of the passband of the receiver.

It will be noticed that as the selectivity control is advanced in a clockwise direction a point will be reached when the Q-Multiplier will break into self-oscillation. This condition will be noticed as the selectivity control reaches the end of the portion marked CW around the selectivity control.

There are three approximate settings of the selectivity control that will generally produce the desired selectivity for a particular mode of transmission. It should be noted that generally the selectivity will be in the OFF position for AM reception. In some cases the selectivity will just be turned on when it is desirable to reduce the selectivity to eliminate interfering stations. The selectivity should be turned on and advanced into the SSB marking to receive SSB signals properly. In actuality the passband required for SSB is one-half that required for AM thereby the selectivity should be less than that used when receiving AM signals. When receiving CW signals the selectivity should be

THE BANDSPREAD LOGGING SCALE CAN BE USED QUITE ACCURATELY WHEN PROPERLY SET UP. THE TABLE AND GRAPH BELOW REPRESENT THE RANGE OF THE BANDSPREAD LOGGING SCALE AT EIGHT DIFFERENT LOCATIONS OF THE DIALS. OTHER TABLES CAN BE MADE FOR FREQUENCIES OTHER THAN THOSE IN THE TABLES. AS AN EXAMPLE ASSUME THE DESIRED STATION TO BE MONITORED IS RADIO STATION CHFO, AT 9.74 MHz FROM MONTREAL, QUEBEC. THE MAIN DIAL WOULD BE SET TO 10.0 MHz WITH THE BANDSPREAD DIAL SET TO 100 ON THE LOGGING SCALE. LOOKING AT THE GRAPH READ FROM 10.0 MHz (IN COLUMN C) HORIZONTAL UNTIL INTERSECTING WITH THE LINE ON THE GRAPH. IT CAN BE SEEN THAT THIS CORRESPONDS TO 100. NOW UNDER 10.0 MHz GO DOWN TO 9.74 AND PROJECT A LINE HORIZONTAL TO INTERSECT WITH THE LINE ON THE GRAPH. WHERE THE PROJECTED LINE INTERSECTS THE GRAPH, READ DOWN TO OBTAIN THE NUMERICAL SETTING WHICH IS 80 FOR THIS STATION. THE BANDSPREAD DIAL WOULD THEN BE SET TO 80 TO RECEIVE RADIO STATION CHFO AT 9.74 MHz.

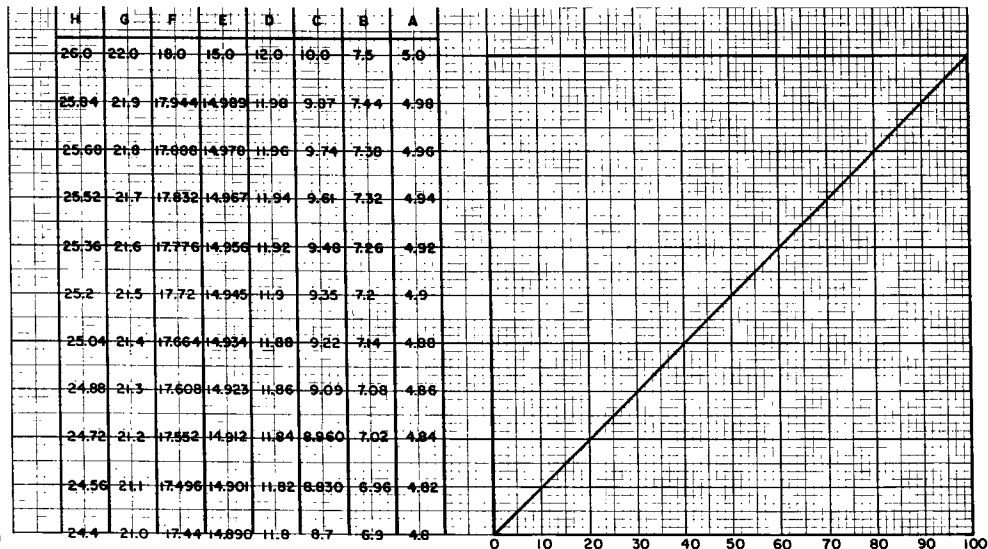

FIGURE 2-2. USE OF BANDSPREAD LOGGING SCALE.

advanced even further to decrease the bandwidth. CW signals require very little bandwidth and the selectivity may be decreased almost to the point where self-oscillation occurs.

It will be noted that a slight loss of signal strength is apparent when the selectivity is first turned on. This is a normal condition and as the selectivity is advanced clockwise the strength will increase slightly.

#### 2.2.11 FREQUENCY CONTROL, Q-MULTIPLIER (Index #11)

The use of the Frequency Control was previously explained in Section 2.2.10. The frequency control and the selectivity control (Index #10) make up the Q-Multiplier. The frequency control will have no effect unless the selectivity control is advanced past the OFF position. The frequency control should be adjusted for clarity of signal or for minimum adjacent channel interference.

#### 2.2.12 BFO FREQUENCY CONTROL (Index #12)

The BFO Frequency Control varies the frequency of the beat frequency oscillator. This control is used when receiving CW or SSB signals. The beat frequency oscillator is turned on when the function switch (Index #1) is placed in the CW/SSB position. When receiving SSB signals this control should be placed to one side depending on the type of SSB to be received. When receiving CW signals the signal should first be zeroed using either the main or bandsread tuning then the BFO control adjusted to produce the desired beat note.

#### 2.2.13 ELECTRICAL BANDSPREAD DIAL (Index #13)

The Electrical Bandsread is a means of enlarging a portion of the main dial. A small segment of the main dial can be "spread-out" and tuned using the

bandsread dial. The bandsread dial is calibrated for use on the 10,15,20,40 and 80 meter amateur bands. In addition there is a logging scale for use on the CB band or for short wave stations. The following paragraphs describe the use of this dial for amateur bands as well as short wave bands.

When using the bandsread dial on one of the amateur bands it is first necessary to set the main dial to the proper frequency. The amateur bands are clearly marked on the main dial by the block marked under the frequency for each band for which the bandsread dial is calibrated. As an example assume the desired band to be the 40 meter band. The band selector switch (Index #2-6) would be placed in the 4-10 position and the main dial control (Index #2-3) rotated until the hair line is over the mark that indicates the right hand end of the block that runs from 6.75 to 7.31 MHz. When the main dial is set this way it is setting just past 7.3 MHz (third mark past 7.0 MHz). The bandsread dial is then rotated from 100 to 0 on the logging scale or from 7.3 to 6.76 which is calibrated for the 40 meter band. This same procedure is followed for any amateur band. The only difference being the 20 meter band, where the band selector switch (Index #2-6) must be placed in the 20 BS position for the calibration to be accurate on the bandsread dial.

The bandsread dial is also very useful when tuning short wave bands even though there is no bandsread calibration for these bands. For an example assume the desired band to be the 16 meter band (17.7 MHz - 18.1 MHz). The band selector switch (Index #2-6) will be placed in the 10-30 position and the main dial control (Index #2-3) rotated until the hair line is at the right hand end of the red block under 18.0 on the main dial. The bandsread dial can now be rotated from 100 to 0 on the logging scale. This will tune from the high frequency end of the 16 meter band thru the low frequency end of the band. The use of the logging scale is realized here. With the main dial set as above and the

bandsread dial rotated down the logging scale assume the desired shortwave station is heard when the logging scale indicates 74. This is the reading that would be remembered or recorded in order to return to this station with a minimum of tuning.

The same principals are followed to use the CB position of the bandsread dial. The main dial would be set to the right hand end of the block just under 27.2 MHz and thereby cause the CB band to appear between 77 and 90 on the logging scale.

#### 2.2.14 MAIN TUNING DIAL (Index #2-14)

The Main Tuning Dial is used to tune the receiver to the desired frequency or the desired band of frequencies when using the bandsread dial. It must be noted that the calibration of the main dial is accurate ONLY when the hair line on the bandsread dial is over 100 on the logging scale on that dial. When set this way the frequency is read directly from the main dial.

The main dial is marked in a manner that allows the frequency to be easily located and read off. The amateur bands (10, 15, 20, 40 and 80 meters) are blocked off just under the frequencies of these bands. The shortwave bands are blocked off in red just under the frequencies for these bands. Some of the shortwave bands marked are the 12, 13, 16, 19, 25, 31, 41, 49 and 60 meter bands as well as others.

#### 2.2.15 "S" METER (Index #2-15)

The "S" Meter will show a relative indication of received signal strength. The meter will function only when the AVC-MAN switch (Index #2-5) is in the AVC position and the function switch (Index #2-1) is in the AM position. The meter is calibrated to +60db over S-9. Each "S" unit from S-1 to S-9 is equal to approximately 6db. The meter will be found useful when tuning AM stations as these stations

may be "peaked-up" using the "S" meter as an indicator by which to tune.

#### 2.3 TUNING AM SIGNALS

When receiving AM signals the controls should be set or manipulated as described below.

- A. Function Switch - AM
- B. Sensitivity - maximum clockwise rotation
- C. Audio Gain - to suit operator
- D. Bandsread dial - set to 100 on logging scale (setting of this dial can be changed later if desired to tune a band)
- E. MAN-AVC Switch - AVC position

Place the tuning range switch to the position that is desired to receive the particular frequency and tune the main dial to that frequency. Peak the station received on the "S" meter using the main dial control and the antenna trimmer control to peak the signal. If impulse noise is present the noise limiter may be turned on to limit this noise and produce a more readable signal. The selectivity will normally be in the OFF position when receiving AM signals to permit a wider bandpass which is more desirable for AM signals to produce a signal with higher fidelity. It is possible to use the selectivity when receiving AM signals and it may be desirable when tuning shortwave bands where the stations are close together. Turn the selectivity on but still turned counterclockwise. This will produce a more narrow bandwidth thereby eliminating the adjacent station or reducing it in strength to reduce the interference caused by it. With the selectivity switch tuned on the Q-Multiplier frequency control is now effective. This control may be used to peak the desired signal or null the undesired signal. By tuning the control it is seen that the signal can be peaked up or "tuned-out" by proper placement of this frequency control.

#### 2.4 TUNING CW SIGNALS

When receiving CW signals the controls

should be set or manipulated as described below.

- A. Function Switch - CW/SSB
- B. Audio Gain - maximum clockwise rotation
- C. Sensitivity - to suit operator
- D. MAN-AVC - MAN position
- E. BFO - Zero "0"
- F. Bandsread Dial set to 100 on logging scale (setting of this dial can be changed later if desired)

Place the tuning range switch in the position desired to tune the particular frequency and rotate the main dial to the frequency desired. The tone of the CW signal should never be set using the dials. The signal should be "zeroed" using the dials, then the BFO adjusted for the desired tone. The antenna trimmer will be peaked to provide maximum signal strength. The noise limiter may be used if conditions are existing that cause interference. It will be found highly desirable to narrow the selectivity of the receiver when tuning CW signals. This is accomplished by turning the selectivity on and advancing the control into the CW marking around the control. The actual setting will be determined by the amount of selectivity required for a particular signal. The Q-Multiplier frequency control is effective when the selectivity is turned on and it will be noticed that the effect of this control is very pronounced now that the selectivity control is advanced into the CW portion of the markings. The peaking effect of this frequency control will be very sharp now and the control will be very useful in peaking the desired signal or nulling the undesired signal.

## 2.5 TUNING SSB SIGNALS

When receiving SSB signals the controls should be set or manipulated as described below. It is suggested that some time be spent in tuning SSB signals to become familiar with tuning this particular type of signal.

- A. Function Switch - CW/SSB
- B. Audio Gain - maximum clockwise rotation

- C. Sensitivity - to suit operator
- D. MAN-AVC - MAN position
- E. Bandsread Dial - set to 100 on logging scale (setting of this dial can be changed later if desired)
- F. BFO - either LSB or USB. This setting can usually be determined by the frequency, but not always. The accepted or most popular transmission of single sideband signals insofar as the sideband used will be as follows:

BAND	FREQUENCY	SIDEBAND
80 meters	3.8-4.0 MHz	lower
40 meters	7.2-7.3 MHz	lower
20 meters	14.2-14.35 MHz	upper
15 meters	21.25-21.45 MHz	upper
10 meters	28.5-29.7 MHz	upper

A SSB signal may be identified by the lack of a carrier or beat note when tuning across the signal. A SSB signal not properly tuned may sound distorted. Intelligibility can only be obtained by proper choice of upper (USB) or lower (LSB) sideband.

The signal would be found using the tuning range switch to select the desired band of frequencies and tuning the main dial to the particular frequency. When located the signal would be peaked using the antenna trimmer. If impulse noise is present the noise limiter may be turned on to eliminate this type of interference.

The selectivity should be turned on and advanced until it is in the SSB portion marked around the control. This will aid in eliminating adjacent stations and provide the passband required for good reception of SSB signals. The frequency control of the Q-Multiplier may be peaked on the desired signal or set to attenuate the undesired signal.

## 2.6 WHERE TO LISTEN

Where you will want to listen will depend on your own personal interests. The following paragraphs are intended to aid the shortwave listener, the ham,

and the persons operating on the citizens band.

### 2.6.1 SHORTWAVE LISTENING

If your prime interest is in short wave listening, you want to find the stations with a minimum of fuss. It's simple if you know where and when to listen.

There are seven bands or areas packed with stations broadcasting from various corners of the world. Here you will hear the voices of London, Paris, Rome, Moscow, etc.

Experience and practice will soon lead you to the proper band at the proper time of day but until you have become familiar with the routine, here is a listing that will help you to get started in the right way.

There are hundreds of broadcast stations throughout the world operating around the clock. Foreign broadcast stations can be heard from about 3,000 kHz up to 28,000 kHz. For convenience, they are grouped into "meter bands" or segments designated by numbers; the 31 meter band covers those frequencies from 9,200 kHz to 9,700 kHz; the 16 meter band, frequencies from 17,700 kHz to 17,900 kHz, etc.

#### International Short-Wave Broadcast Bands

Meters	Frequency Range
60.....	4750 to 5060 kHz
49.....	5950 to 6200 kHz
41.....	7100 to 7300 kHz
31.....	9200 to 9700 kHz
25.....	11700 to 11975 kHz
19.....	15100 to 15450 kHz
16.....	17700 to 17900 kHz
13.....	21450 to 21750 kHz

#### WHEN TO LISTEN

Short Wave Bands-From the U.S.A.

##### Daybreak to Noon:

16 meters	Mainly for stations to the East
19 meters	Mainly for stations to the Northeast, East or Southwest.

25 meters	Mainly for stations to the Northeast, East or Southwest
49 meters	Mainly for stations to the Northeast, East or Southwest

##### Noon to Sunset:

16 meters	Stations to the East which fade and are replaced by those to the South before sunset
19 meters	East and South
25 meters	East and South
31 meters	Stations to the East
49 meters	Inconsistent

##### Sunset to Midnight:

16 meters	Poor
19 meters	Poor
25 meters	Poor
25 meters	Stations from East fade around midnight. Station from South usually quite strong.
31 meters	Stations from East fade around midnight. Station from South usually quite strong.
49 meters	Stations are strongest from the East. North-South reception usually good.

The 13 meter band exhibits much the same characteristics as the 16 meter band; the 41 meter band follows the 49 meter band closely.

The above listed conditions apply to the spring and autumn of the year. During the winter months evenings, the 41, 49 and 60 meter bands are loaded with short wave stations; during the summer months, these same frequencies fade and are replaced by the higher frequencies for consistent listening.

For year'round listening, the 31 and 25 meter bands are the ones which produce the most in the way of stations.

As a general rule, the shorter wavelengths (higher frequencies) cover the greatest distances by daylight; the longer wavelengths are more effective during the evening hours.

Sun spots, which have a direct relationship to receiving conditions, operate on an 11 year cycle. As the number of sun spots



increase, conditions improve on the higher frequencies particularly and the 13 meter band will enjoy a marked increase in activity from 1968 on.

## 2.6.2 HAM RADIO

Various segments of the radio spectrum have been set aside for use by radio amateurs or "hams" who are licensed to operate their own radio transmitters. Communicating across thousands of miles of land and sea and across international borders, the chatter of thousands of hams around the world fills the air around the clock.

Conversations are often technical in nature but there is plenty of interesting "rag-chewing" or general conversation. Hams often provide emergency communications in disaster areas using portable and vehicle mounted equipment.

The ham frequencies you will find on your Hammarlund receiver are listed below:

Meters	Frequency in kHz
160.....	1800-2000
80.....	3500-4000
40.....	7000-7300
20.....	14000-14350
15.....	21000-21450
10.....	28000-29700

NOTE: New FCC regulations concerning suballocations effective Nov. 22, 68.

Radio station WWV at Fort Collins, Colorado and WWVH in Hawaii, broadcast continuously on the frequencies 2.5 MHz, 5 MHz, 15 MHz, 20 MHz and 25 MHz. Services provided include time signals receiver calibration and propagation forecasts which are of assistance to the short wave listener.

The chart below indicates the code groups used for propagation reporting.

### Standard Frequency Station and Propagation Reports

Station	Frequency in MHz
WWV*	2.5, 5, 10, 15, 20, 25
WWVH*	5, 10, 15

CHU	3,330, 7,335, 14.67
JJY	2.5, 4, 5, 8, 10, 15

### Location

WWV - Ft. Collins, Colorado  
 WWVH - Hawaii  
 CHU - Ottawa, Canada  
 JJY - Tokyo, Japan

\* Propagation Reports Broadcast as Follows:  
 For North Atlantic Area - WWV, forecast occurs the last half of every fifth minute.  
 For North Pacific Area - WWVH, forecast occurs the last half of every fifth minute.  
Code Letter W ( \_ \_ \_ ) = Disturbance Either in Progress or Expected.

U ( \_ \_ \_ ) = Unstable Conditions

N ( \_ . ) = No Warning

Code letter followed by number which gives quality of report:

1. ( \_ \_ \_ \_ ) Impossible
2. ( . \_ \_ \_ ) Very poor
3. ( \_ . \_ \_ ) Poor
4. ( \_ . . . ) Fair to poor
5. ( \_ . . . ) Fair
6. ( \_ . . . ) Fair to Good
7. ( \_ . . . ) Good
8. ( \_ . . . ) Very Good
9. ( \_ . . . ) Excellent

## 2.6.3 CITIZENS BAND

A recent addition to private communication is the Citizen Band of frequencies, set up by the FCC for short range business and personal communication. It consists of 23 channels between 26.965 and 27.255 kHz. Your Hammarlund receiver will receive these channels.

### LOCATION OF CITIZENS BAND

Ch.	Freq. in kHz.	Ch.	Freq. in kHz
1	26965	13	27115
2	26975	14	27125
3	26985	15	27135
4	27005	16	27155
5	27015	17	27165
6	27025	18	27175
7	27035	19	27185
8	27055	20	27205
9	27065	21	27215
10	27075	22	27225
11	27085	23	27255
12	27105		

## SECTION 3 THEORY OF OPERATION

### 3.1 GENERAL

This section will aid in understanding the operation of the various circuits in this receiver as well as aid in servicing and diagnosing troubles. The HQ-200 is a single conversion receiver using a variable frequency oscillator to provide the mixing. The mixer being connected to the IF circuitry which consists of six tuned stages and two IF amplifiers. After amplification the detection is accomplished by two separate detectors; one for AM and the other for CW and SSB. The AM detector is a solid state diode and the detector for CW and SSB is part of a pentagrid converter. The beat frequency oscillator being the remaining part of this converter. The audio detected by either the AM detector or the product detector passes by the shunt noise limiter and on to the first audio amplifier. The output of the first audio amplifier is directly coupled to the final audio amplifier where it is amplified and fed to the speaker terminals and phone jack simultaneously.

The complete circuit of the HQ-200 is shown in the schematic diagram at the rear of the manual. While reading the text in this section it is suggested that the circuitry be followed on the schematic.

### 3.2 RF AMPLIFIER AND HIGH FREQUENCY OSCILLATOR

The RF signal received at the antenna is applied to the primary of the particular antenna transformer selected by a section of the band switch (S1A). The signal is coupled from the secondary of the transformer to the grid of the RF amplifier tube V1 (6BZ6). The secondary of the antenna transformer is tuned by the antenna trimmer as well as one section of the main tuning unit C1. The RF tube, whose gain is controlled by the AVC voltage, amplifies the signal. The output of the RF amplifier is

coupled to the grid of the mixer (V2) thru a tuned circuit consisting of the RF coils and sections of the air variable capacitors C1 and C2.

The high frequency oscillator is a Hartley oscillator consisting mainly of the oscillator coils for the various bands and the variable capacitors. The oscillator tube is a 6C4 triode (V3) whose plate voltage is regulated by the zener diode CR3. The output of this oscillator is taken from the grid of the oscillator and fed to the mixer (V2) tube. This oscillator operates 455 kHz above the signal frequency.

### 3.3 MIXER AND IF AMPLIFIERS

The mixer tube is a 6BE6 pentagrid converter. The output from the RF amplifier and the output from the high frequency oscillator are applied to separate grids of the mixer. The two signals are mixed and their product is selected by the tuned circuit in the plate of the mixer tube. The plate of the mixer tube, as well as the two IF amplifier tubes following the mixer, is tuned to the IF frequency of 455 kHz. All six of the tuned circuits ( 3 plates and 3 grids) consist of permeability tuned transformers. The gain of the two IF amplifiers is controlled manually by the front panel sensitivity control (R2). When using AVC the first IF amplifier (V5) has its gain controlled by AVC. The output of the last IF amplifier is fed to the AM detector as well as the product detector.

### 3.4 Q-MULTIPLIER

The Q-Multiplier circuitry is composed of V4A ( $\frac{1}{2}$ -12AX7) and its associated components. The Q-Multiplier is connected in the grid circuitry of the 2nd IF amplifier. When turned on the Q-Multiplier controls the selectivity of the receiver. The selectivity of the receiver is cut approximately to one-half when the Q-Multiplier is first turned on.

As the selectivity control (R13) is turned clockwise the selectivity becomes sharper. This control allows the selectivity to be varied from approximately 3 kHz to 100 hertz. The frequency control will allow the sharp peak, created by multiplying the Q of L5, to be moved thru the IF passband of the receiver. This control will allow the peak to move  $\pm 3.5$  kHz of the center frequency of 455 kHz.

### 3.5 AVC AND "S" METER

The AVC detector is a 1N34A diode (CR4). The AVC is filtered by part of the chip Z2. The MAN-AVC switch (S4) controls the feed of the AVC to the RF amplifier (V1) and the 1st IF amplifier (V5). When in the MAN position the AVC bus is at ground potential and the RF amplifier and 1st IF amplifier gain must be manually controlled.

The "S" meter is in the cathode circuitry of the two IF amplifiers. The "S" meter will indicate only when the MAN-AVC switch is in the AVC position. The current through the meter is caused by a difference of potential existing between the cathode of the two amplifiers. This condition exists only when the 1st IF amplifier has its gain controlled by the AVC voltage.

### 3.6 PRODUCT DETECTOR AND BFO

The output from the last IF amplifier is coupled to the pentagrid converter tube used for the product detector and beat frequency oscillator. This tube (V7-6BE6) functions as a Hartley oscillator to perform the function of the BFO and a product detector to detect CW and SSB signals. The beat frequency oscillator is variable  $\pm 2$  kHz from the center frequency of 455 kHz. This single stage combines the output of the last IF and the BFO to produce their products in its output. The 455 kHz component is filtered and the audio is passed on to the 1st Audio amplifier.

### 3.7 NOISE LIMITER AND AUDIO AMPLIFIERS

The noise limiter consists of a 1N541 diode (CR5) which is connected in a shunt type configuration. The audio from either the AM detector or product detector must pass the noise limiter prior to reaching the 1st audio amplifier. The noise limiter switch (S5) places a shunt across CR5 when in the OFF position. When in the ON position the diode is allowed to clip impulse noise.

There are two audio amplifiers. The first audio amplifier consists of V4B which is  $\frac{1}{2}$  of a 12AX7. The output of the first audio amplifier is filtered and fed to the final audio amplifier. The final audio amplifier, V8, is a 6AQ5. This stage amplifies the audio and drives the audio output transformer T8 whose secondary is directly coupled to the audio output terminals and the phone jack. The speaker used with the receiver should be 3.2 ohm. If headphones are used they should be of a low impedance variety.

### 3.8 POWER SUPPLY

The power supply consists of the power transformer (T9), the rectifiers (CR1 and CR2) and the necessary filtering. The silicon diodes are connected in the conventional full wave rectifier configuration.

The power transformer has the capability of allowing the receiver to operate on either 110 VAC 50/60 Hertz or 220 VAC 50/60 Hertz provided the primary of the power transformer is programmed properly. To use the receiver on 110 VAC the primary should be connected as follows: black to black/green and black/yellow to black red, this corresponds to 1 to 2 on T81 and 3 to 4 on T81. To use the receiver on 220 VAC the jumpers used for 110 VAC should be removed and the primary programmed as follows: black/yellow to black/green, jumper 2 and 3 together on T81. When changing from 110 VAC to 220 VAC the fuse, F1, should be changed from

1 amp to 2.5 amp.

The power transformer has a separate winding which supplies the necessary voltage to operate the pilot lamps and the necessary filament voltages.

A voltage reading of 45 - 50 volts may be obtained between the chassis and a ground as the result of the two power line by-pass capacitors that are connected across the power line with the center tap grounded. Since we are

dealing with AC, these capacitors will look like resistors to a volt meter. This will also produce a slight shock if the chassis is not grounded and one happens to contact a grounded object, and the chassis or any exposed part of the receiver. This also will account for a slight spark, if the receiver is connected to the power line and the ground connection is made. For protection a good ground should always be employed.

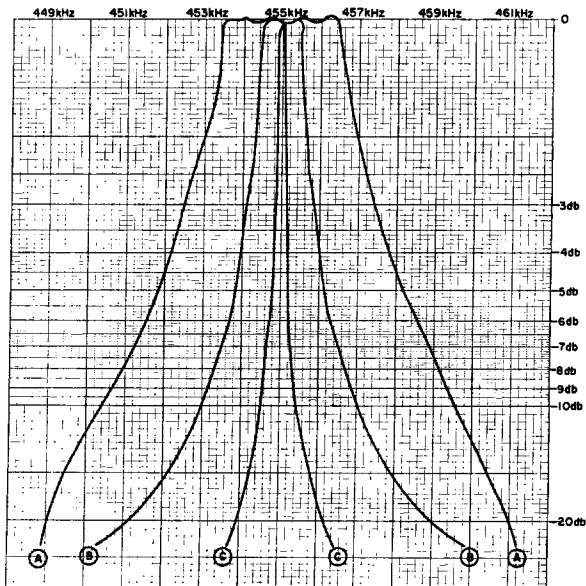

- (A) HQ-200 IF SELECTIVITY WITH SELECTIVITY CONTROL IN "OFF" POSITION. NOMINAL 6DB BANDWIDTH OF 7.0 kHz.
- (B) HQ-200 IF SELECTIVITY WITH SELECTIVITY CONTROL TURNED "ON" BUT COUNTERCLOCKWISE. NOMINAL 6DB BANDWIDTH OF 2.5 kHz.
- (C) HQ-200 IF SELECTIVITY WITH SELECTIVITY CONTROL TURNED "ON" AND ADVANCED TO CW POSITION. NOMINAL 6DB BANDWIDTH OF 400 Hertz.

FIGURE 3-1. IF SELECTIVITY.

#### 4.1 GENERAL

This section will provide instructions for the correct servicing of the HQ-200 Receiver. It includes information on resistance measurements, voltage measurements, trouble analysis, and alignment procedures. It should be noted that proper tools and test equipment must be available to undertake the electrical measurements and alignments. The accuracy of the test equipment used will determine the validity of the signal level measurements and alignment data. This receiver has been carefully designed, constructed, inspected and aligned at the factory to provide a long period of trouble-free use. Except for an occasional touch up to compensate for component ageing, alignment will normally be necessary only if frequency determining components have been replaced. The enclosure of the receiver has been designed to allow easy removal for such maintenance as is required.

##### 4.1.1 ENCLOSURE REMOVAL

To service this receiver, disconnect from power source and remove all leadwires attached to terminal connections at rear of chassis apron. Carefully turn the receiver up onto the front panel face on a smooth clean surface. Remove the two #10 hex machine screws at the extreme ends of the chassis apron at the rear of the cabinet. Lift cabinet straight up and off of chassis. To reassemble, use reverse procedure.

#### 4.2 TROUBLE ANALYSIS

Many cases of trouble can be traced to improper adjustments or defective components. Troubleshooting this receiver is simple with the proper procedures and proper test equipment. In troubleshooting the receiver, one must perform various tests and make certain observations. Proper interpretation of the results of these tests will indicate the problem area. Additional tests in the problem area will then locate the bad

components or assembly. In the event of a component failure assume that the defective part is not the cause of the trouble but a symptom of a more serious problem. For example, a burned resistor may result from a shorted tube or capacitor. Making the measurements outlined in Tables 4-1 and 4-2 will aid in isolating a problem to a particular stage or component.

An orderly process of elimination coupled with a study of the theory of operation outlined in Section 3 as well as a study of the schematic diagram will aid in isolating trouble. An example of this would be that the receiver performs all right on AM but fails to function on CW. Inspection of the block diagram and schematic will reveal that the only circuit peculiar to CW reception is V7 and its' associated components. Checking the voltages and components in this stage should readily yield the source of difficulty.

If the receiver is to be returned to the factory or an authorized service agency for any reason, a detailed report should accompany the receiver. A report such as this will assist in locating the difficulty with a minimum of time and expense.

IT IS REQUIRED BEFORE RETURNING ANY EQUIPMENT TO THE FACTORY THAT WRITTEN AUTHORIZATION BE OBTAINED FROM THE FACTORY.

#### 4.3 VOLTAGE MEASUREMENTS

The voltages contained in Table 4-1 are typical readings and will vary slightly from unit to unit. The voltage measurements in Table 4-1 were made under the following conditions:

- A. Voltages in Table 4-1 were made using a VTVM.
- B. Audio Gain - Maximum counterclockwise
- C. Sensitivity - Maximum clockwise
- D. Function switch - AM
- E. AVC-MAN - MAN
- F. LIMITER - OFF
- G. Band Selector - 10-30 MHz
- H. Selectivity - OFF

TABLE 4-1 TUBE SOCKET VOLTAGES

TUBE AND FUNCTION	SOCKET PIN NUMBERS								
	1	2	3	4	5	6	7	8	9
V1 RF 6BZ6	-	1.8	6.3AC	-	220	110	-	-	-
V2 MIXER 6BE6	-2.5	1.2	6.3AC	-	220	80	-	-	-
V3 HFO 6C4	115	-	6.3AC	-	110	-1 to -9	-	-	-
V4 12AX7 Q MULT. 1st A-F	115	-	1.4	-	-	200	-	1.5	6.3AC
V5 1st IF 6BA6	-	-	6.3AC	-	215	115	2.2 20 MIN SENS	-	-
V6 2nd IF 6BA6	-	-	6.3AC	-	215	115	2.2 20 MIN SENS	-	-
V7 6BE6 BFO Prod. Det.	-3 to -5 BFO ON	-	6.3AC	-	145 BFO ON	65 BFO ON	-1 to -2 BFO ON	-	-
V8 6AQ5 AUDIO OUTPUT	-	14	6.3AC	-	240	230	-	-	-

TABLE 4-2 TUBE SOCKET RESISTANCES

TUBE AND FUNCTION	SOCKET PIN NUMBERS								
	1	2	3	4	5	6	7	8	9
V1 RF 6BZ6	10K, 2.4M ON AVC	180	0	0	.5 MEG	.5 MEG	0	-	-
V2 MIXER 6BE6	22K	180	0	0	.5 MEG	.5 MEG	0	-	-
V3 HFO 6C4	.5 MEG	INF	0	0	.5 MEG	47K	0	-	-
V4 12AX7 Q MULT. 1st AF	.5 MEG	2.2 MEG	16K SEL OFF	0	0	.5 MEG	1MEG	4700	0
V5 1st IF 6BA6	13 $\Omega$ , 2.4M ON AVC	0	0	0	.5 MEG	.5 MEG	180, 10K MIN SENS	-	-
V6 2nd IF 6BA6	470K	0	0	0	.5 MEG	.5 MEG	300, 10K MIN SENS	-	-
V7 6BE6 BFO Prod. Detector	100K	0.5 $\Omega$	0	0	.5 MEG BFO ON	.5 MEG BFO ON	220K	-	-
V8 6AQ5 Audio Output	470K	430	0	0	.5 MEG	.5 MEG	470K	-	-

## MODEL HQ-200

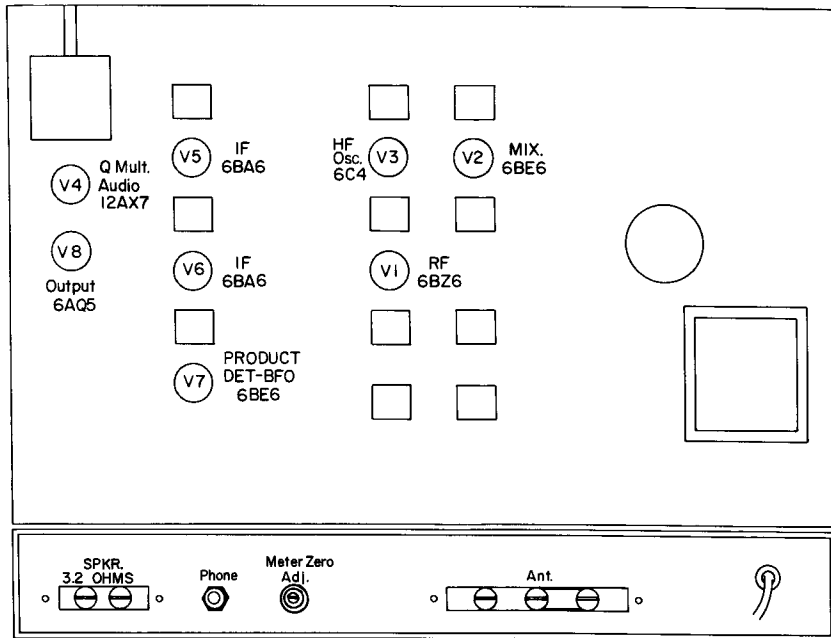

FIGURE 4-1. TUBE LOCATION.

## I. No Signal Input

### 4.4 RESISTANCE MEASUREMENTS

It is probable that resistance measurements will vary somewhat from meter to meter. On many ohmmeters just changing the resistance scale will cause a different reading. The measurements contained in Table 4-2 were made using a Simpson 260 VOM with negative lead of meter connected to receiver chassis. The following settings were observed for control settings:

- A. Audio Gain- maximum clockwise
- B. Sensitivity- maximum clockwise
- C. Function Switch- AM
- D. AVC-MAN- MAN
- E. Limiter- OFF
- F. Band Selector- 10-30 MHz
- G. Selectivity- OFF

### 4.5 IF ALIGNMENT

It should be noted that a non-metallic alignment tool such as a nylon hex alignment (General Cement Co. No. 8282 or equal) tool should be used to align the receiver.

#### 4.5.1 455 kHz IF ADJUSTMENT

- A. Connect the output cable of a 455 kHz unmodulated, signal generator to the bus lead of the 6BE6 mixer grid. The frequency accuracy of the generator may be checked with sufficient precision by picking up its second harmonic (910 kHz) in any receiver whose calibration at 910 kHz has been checked as correct and then adjusting the generator frequency.
- B. Connect a DC vacuum tube voltmeter, set for negative voltage reading to pin 2 of Z2.
- C. Set the receiver controls as follows:

BAND SPREAD dial to 100  
Function switch to AM  
Main tuning dial to .60 MHz  
Noise limiter switch to OFF  
AUDIO GAIN control at minimum  
SELECTIVITY control to OFF

Band selector switch on .54-1.6 MHz  
MAN-AVC switch on AVC  
SELECTIVITY maximum clockwise

D. During alignment, adjust the generator output to prevent over-loading. Adjust each of the three IF transformers for maximum meter reading. Topside adjustments (Figure 4-1) are secondaries or grid circuits; bottom of chassis adjustments (Figure 4-2) are primaries or plate circuits. The reading on the voltmeter should be kept below -3.0 volts.

#### 4.5.2 Q-MULTIPLIER ADJUSTMENT

Turn the Q-Multiplier on and adjust the SELECTIVITY control clockwise to a position below the oscillating point. With its panel bushing nut loosened to permit the frequency shaft to turn without hindrance by the stop, adjust the FREQUENCY control to obtain a maximum meter indication. The input signal must be adjusted to a value just sufficient to obtain a good meter swing. This adjustment is the center frequency of the pass band. While the meter is at maximum, turn the stop lug to a position 180 degrees directly opposite the stop pin in the frequency shaft. Holding it in this position, tighten the bushing in the nut making sure that the shaft or the stop lug have not turned by checking the zero setting.

#### 4.5.3 BFO ADJUSTMENT

Rotate the function switch to the CW/SSB position and place the MAN-AVC switch in the MAN position. With the BFO frequency control on ZERO adjust the slug in L7 for zero beat. The correct setting for the BFO frequency control capacitor (C59) is as follows: with the knob pointing to LSB the capacitor should be set for full mesh (maximum capacity), with the control rotated clockwise to "0" the capacitor will be at half mesh, and rotated further until the knob points to USB where the capacitor will be fully open (Minimum capacity).

#### 4.5.4 ZERO ADJUST FOR "S" METER

Place the MAN-AVC switch in the AVC



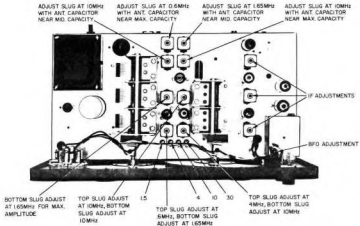

FIGURE 4-2. HQ 200 TOP VIEW.

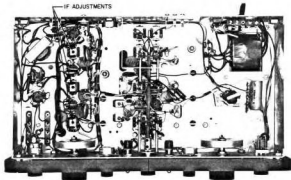

FIGURE 4-3. HQ 200 BOTTOM VIEW.

position. With no signal input, ground the grid of the mixer (V2-6BE6) pin 7 and zero the "S" meter using R15 to adjust the zero reading.

#### 4.6 RF ALIGNMENT

NOTE: Use a non-metallic alignment tool such as General Cement Co. No. 8282, or equal.

- A. The slugs and trimmers, having been factory adjusted, should require a minimum amount of adjustment for any alignment.
- B. All RF and oscillator slug adjustments are made from the top of the shield cans. See Figure 4-1.
- C. Connect the unmodulated, signal generator output cable to the antenna and ground terminals of the receiver, with the A terminal adjacent to the G terminal jumped together.
- D. Set the controls the same as for IF alignment above.
- E. The oscillator adjustment is made first. The RF is adjusted next to obtain maximum amplitude. The antenna slugs are adjusted last. A certain amount of interaction will occur between the oscillator and RF adjustments, particularly on the higher frequency bands. Final adjustment should be accomplished by combined or alternate adjustment of the oscillator and RF for maximum amplitude.

Figure 4-1 indicates the particular adjustment for each band of the receiver and the frequency at which they are to be adjusted.

There is no RF amplifier adjustment for the .54 - 1.6 MHz band.

- F. Note that the oscillator frequency in the HQ-200 is always on the high side of the signal frequency by 455 kHz. Therefore, it is necessary to make sure that the oscillator frequency is not adjusted below the signal frequency which would be an image response of the signal.

G. It will be necessary to repeat low and high end alignment adjustments of each band since the adjustments are interdependent. The process should be repeated until maximum amplitude is obtained at both alignment frequencies of each band.

NOTE: The receiver should be warmed up at least one-half hour before final oscillator frequency adjustments are made for the dial calibration check.

#### 4.7 DIAL CALIBRATION

- A. Use a crystal calibrator having 100 kHz and 1 MHz output. Set the arbitrary band spread dial scale to 100. Set the function switch to CW/SSB. Set the BFO Frequency control to ZERO. Set the SELECTIVITY control to OFF. Set the MAN-AVC switch to MAN.
- B. Check to see that the frequencies at or near the alignment frequencies are "on the line". If not, make minor adjustments of the slugs and trimmers (Figure 4-1) to make them correct.

#### CAUTION

Weaker signals will be observed at dial settings approximately 10 kHz above each calibration dial marking. These are image signals from 1 MHz above the desired signal and may be recognized by their somewhat weaker strength and may be further reduced by proper adjustment of the gain controls. They will, of course, be more noticeable on the higher bands. Keeping the antenna tuned will help.

## SECTION 5 PARTS LIST

ITEM	DESCRIPTION	HAMMILLUND PART NO.
<b>Capacitors</b>		
C1, A.	Variable, Main Tuning	9441-60-40003
C2, A.	Variable, Bandspread	9441-60-40007
B, C, D	Variable, Antenna Compensator	9434-45-40038
C3	Fixed, Ceramic disc, .01 uF, 1000V	1509-01-01001
C4	Fixed, Ceramic disc, .01 uF, 1000V	1509-01-01001
C5	Fixed, Ceramic disc, .01 uF, 1000V	1509-01-01001
C6	Fixed, Ceramic disc, .01 uF, 1000V	1509-01-01001
C7	Fixed, Ceramic disc, .01 uF, 1000V	1509-01-01001
C8	Fixed, Ceramic disc, .01 uF, 1000V	1509-01-01001
C9	Fixed, Ceramic disc, .01 uF, 1000V	1509-01-01001
C10	Fixed, Ceramic disc, .01 uF, 1000V	1509-01-01001
C11	Fixed, Ceramic disc, .01 uF, 1000V	1509-01-01001
C12	Fixed, Silver mica, 100 pf, 500V	1519-01-00001
C13	Fixed, Silver mica, 100 pf, 500V	1519-01-00001
C14	Fixed, Silver mica, 100 pf, 500V	1518-01-00001
C15	Fixed, Silver mica, 100 pf, 500V	1509-01-01001
C16	Fixed, Silver mica, 100 pf, 500V	1527-01-00002
C17	Fixed, Silver mica, 100 pf, 500V	1527-01-00002
C18	Fixed, Silver mica, 100 pf, 500V	1527-01-00002
C19	Fixed, Silver mica, 100 pf, 500V	1527-01-00002
C20	Variable, 1-8 pf, 500V	1527-01-00002
C21	Variable, 1-8 pf, 500V	1527-01-00002
C22	Variable, 1-8 pf, 500V	1527-01-00002
C23	Variable, 1-8 pf, 500V	1527-01-00002
C24	Fixed, Silver mica, 430 pf, 300V	1519-02-03010
C25	Fixed, Silver mica, 1300 pf, 500V	1519-02-03011
C26	Fixed, Silver mica, 3000 pf, 500V	1519-02-03009
C27	Fixed, Silver mica, 1100 pf, 500V	1519-01-03001
C28	Fixed, Silver mica, 3300 pf, 500V	1519-02-05001
C29	Fixed, Silver mica, 510 pf, 500V	1519-01-03002
C30	Fixed, Ceramic disc, .01 uF, 1000V	1509-01-01001
C31	Fixed, Ceramic disc, .01 uF, 1000V	1509-01-01001
C32	Fixed, Ceramic disc, .01 uF, 1000V	1509-01-01001
C33	Fixed, Ceramic disc, .04 uF, 600V	1509-01-01005
C34	Fixed, Ceramic disc, .01 uF, 1000V	1509-01-01001
C35	Fixed, Ceramic disc, .01 uF, 1000V	1509-01-01001
C36	Fixed, Ceramic disc, .01 uF, 1000V	1509-01-01001
C37	Fixed, Ceramic disc, .01 uF, 1000V	1509-01-01001
C38	Fixed, Three-section electrolytic	1517-01-00004
C38A	60 uF, 450V (Part of 1517-01-00004)	
C38B	40 uF, 450V (Part of 1517-01-00004)	
C38C	25 uF, 50V (Part of 1517-01-00004)	
C39	Fixed, Ceramic disc, .01 uF, 1000V	1509-01-01001
C40	Fixed, Ceramic disc, .01 uF, 1000V	1509-01-01001
C41	Fixed, Ceramic disc, .0027 uF, 1000V	1509-02-01022
C42	Fixed, Silver mica, 330 pf, 500V	1519-02-00071
C43	Fixed, Ceramic disc, .01 uF, 1400V	1509-01-01015
C44	Fixed, Ceramic disc, .01 uF, 1400V	1509-01-01015
C45	Fixed, Ceramic disc, .04 uF, 600V	1509-01-01005
C46	Fixed, Ceramic disc, .04 uF, 600V	1509-01-01005
C47	Fixed, Discap, Temperature Compensating, 6.8 pf, N220	1509-01-00022
C48	Fixed, Ceramic disc, .01 uF, 1000V	1509-01-01001
C50	Fixed, Discap, Temperature Compensating, 2.7 pf, N220	1509-01-00001

ITEM	DESCRIPTION	HAMMILLUND PART NO.
<b>Capacitors (con't)</b>		
C51	Fixed, Discap, Temperature Compensating, 6.8 pf, N220	1509-02-00003
C52	Fixed, Ceramic, Temperature Compensating, non-insulated, 1.5 pf	1509-01-02002
C53	Fixed, Silver mica, 5 pf, 10K, 500V	1519-01-00003
C54	Fixed, Ceramic disc, 4.7 pf, 5K, N220	1509-02-00024
C55	Fixed, Ceramic disc, .01 uF, 1000V	1509-01-01001
C56	Fixed, Silver mica, 350 pf, 20K	1519-02-00053
C57	Fixed, Silver mica, 3000 pf, 500V	1519-02-03009
C58	Fixed, Silver mica, 56 pf, 5K, 500V	1519-01-00087
C59	Variable, 3FO	9434-45-40006
C60	Fixed, Silver mica, 2 pf, +5 pf	1519-01-00024
C61	Fixed, Ceramic disc, .01 uF, 1000V	1509-01-01001
C65	Fixed, Silver mica, 47 pf, 500V	1519-01-00004
C66	Fixed, Silver mica, 330 pf, 500V	1519-02-00071
C67	Fixed, Silver mica, 100 pf, 500V	1519-01-00001
C68	Fixed, Silver mica, 330 pf, 500V	1519-02-00071
C69	Fixed, Silver mica, 100 pf, 500V	1519-01-00001
C70	Fixed, Silver mica, 330 pf, 500V	1519-02-00071
C71	Fixed, Silver mica, 3 pf, 500V	1519-01-00011
C72	Fixed, Ceramic disc, .01 uF, 1000V	1509-01-01001
C73	Fixed, Silver mica, 220 pf, 500V	1519-01-00007
C74	Fixed, Silver mica, 220 pf, 500V	1519-01-00007
C75	Fixed, Electrolytic, 8 uF, 350V	1515-02-05001
<b>Diodes</b>		
CR1	Silicon, CER72C	4807-01-00001
CR2	Silicon, CER72C	4807-01-00001
CR3	Zener, 125V, 110%, 2W (2VR125)	4833-01-00004
CR4	Germanium, 1N34A	4823-02-00001
CR5	Germanium, 1N341	4823-02-00004
<b>Coils</b>		
L1	RF Coil Assembly (Bands 1 & 2)	1809-01-00005
L2	RF Coil Assembly (Bands 3 & 4)	1811-01-00011
L3	HF Osc. Coil Assembly (Bands 1 & 2)	1809-01-00006
L4	HF Osc. Coil Assembly (Bands 3 & 4)	1811-01-00012
L5	Coil and ferrule Assembly	9601-02-00118
L6	Choke, 2.5 mH	1802-01-00015
L7	BFO Coil	1804-02-00055
<b>Resistors</b>		
R1	22K, 1/4W	4703-02-00312
R2	Potentiometer, 10,000	4735-02-00001
R3	10,000, 1/4W	4703-01-00344
R4	1,000, 1/4W	4703-01-00312
R5	22,000, 1/4W	4703-01-00348
R6	180, 1/4W	4703-01-00323
R8	6,200, 1/4W	4703-02-00466
R9	47,000, 1/4W	4703-01-00352
R10	1,000, 1/4W	4703-01-00332

ITEM	DESCRIPTION	HAMMARLUND PART NO.
	<u>Resistors (con't)</u>	
R11	2.2 Megohms, 1/2W	4703-01-00372
R12	6,800 $\Omega$ , 1/2W	4703-01-00342
R13	Potentiometer, 10,000 $\Omega$	4735-01-08002
R14	2,200 $\Omega$ , 1/2W	4703-01-00336
R15	Potentiometer, 300 $\Omega$	4735-01-00400
R16	2,200 $\Omega$ , 1/2W	4703-01-00336
R17	2,200 $\Omega$ , 1/2W	4703-01-00336
R18	500 $\Omega$ , 5W	4713-01-00014
R19	180 $\Omega$ , 5K, 1/2W	4703-02-00429
R20	10,000 $\Omega$ , 5W	4713-01-00015
R21	2,200 $\Omega$ , 1/2W	4703-01-00336
R22	3,000 $\Omega$ , 5W	4713-01-00016
R23	56,000 $\Omega$ , 1/2W	4703-01-00353
R24	22,000 $\Omega$ , 1/2W	4703-01-00348
R25	560,000 $\Omega$ , 1/2W	4703-01-00365
R26	220,000 $\Omega$ , 1/2W	4703-01-00360
R27	potentiometer, 1 megohm	4735-01-00062
R28	6,800 $\Omega$ , 2W	4705-01-00942
R29	4,700 $\Omega$ , 1/2W	4703-01-00340
R30	2,200 $\Omega$ , 1/2W	4703-01-00336
R31	470 $\Omega$ , 1W	4704-01-00738
R32	22 $\Omega$ , 1/2W	4703-01-00312
R33	180 $\Omega$ , 1/2W	4703-01-00323
R34	47,000 $\Omega$ , 1/2W	4703-01-00352
R35	2,200 $\Omega$ , 1/2W	4703-01-00336
R36	10 $\Omega$ , 1/2W	4703-01-00308
R37	470,000 $\Omega$ , 1/2W	4703-01-00364
R38	100,000 $\Omega$ , 1/2W	4703-01-00356
	<u>Switches</u>	
S1A	Switch Wafer, Antenna	5105-01-00007
S1B	Switch Wafer, RF	5105-01-00007
S1C	Switch Wafer, HF Osc.	5106-02-00005
S2	Power-On-Off, SPST (Part of R13)	
S3	OFF-REC-ON/SSB, Single Section, four-position	5106-02-00007
S4	MAN.-AVC, SPST	5101-01-00001
S5	LIMITER, SPST	5101-01-00001
	<u>Transformers and Coil Assemblies</u>	
T1	Antenna Transformer Assem. (Band 1)	1809-01-00004
T2	Antenna Transformer Assem. (Band 2)	1810-01-00010
T3	Antenna Transformer Assem. (Band 3)	1811-01-00010
T4	Antenna Coil Assembly (Band 4)	1812-01-00012
T5	Transformer, 1st. IF	1811-01-00037
T6	Transformer, 2nd. IF	1811-01-00037
T7	Transformer, 3rd. IF	1811-01-00037
T8	Transformer, Output, Max power 5W, impedance match: 10,000 $\Omega$ plate to 4 $\Omega$ voice coil.	5618-01-00002
T9	Transformer, Power, Primary 115V/ 230V 50-60 Hertz	5603-01-00011

ITEM	DESCRIPTION	HAMMARLUND PART NO.
	<u>Miscellaneous</u>	
F1	Fuse, 1 amp, sio-blo, (115V Operation)	5134-02-00002
F1	Fuse, 1/2 amp, sio-blo, (230V Operation)	5134-02-00006
I1	Lamp, Pilot #47, 6.3V, .15A	3901-01-00001
I2	Lamp, Pilot #47, 6.3V, .15A	3901-01-00001
I3	Lamp, Pilot #47, 6.3V, .15A	3901-01-00001
J1	Phone Jack	2109-01-00001
M1	Meter "S" (Carrier Level)	2902-02-00016
Z1	RC Printed Circuit (Audio)	1711-01-00001
Z2	RC Printed Circuit (AVC-ANL-Audio)	1711-01-00002
	Instruction Manual	9001-06-00015
	Crystal Calibrator (100 kHz) XC-100	9205-00-00011
	Fuseholder	5136-02-00009
	Knob, 1 1/2" diameter	2430-01-00062
	Knob, 7/8" diameter	2430-01-00060
	Knob, 1 1/16" diameter	2430-02-00061
	"S" Meter mounting bracket	1450-02-00304
	Dial Window	2411-02-00012
	Bandspread dial and hub assembly	9001-03-00176
	Main dial and hub assembly	9001-03-00010
	Q-Multiplier cover	9001-03-00008
	5 meter frame	2410-02-00068

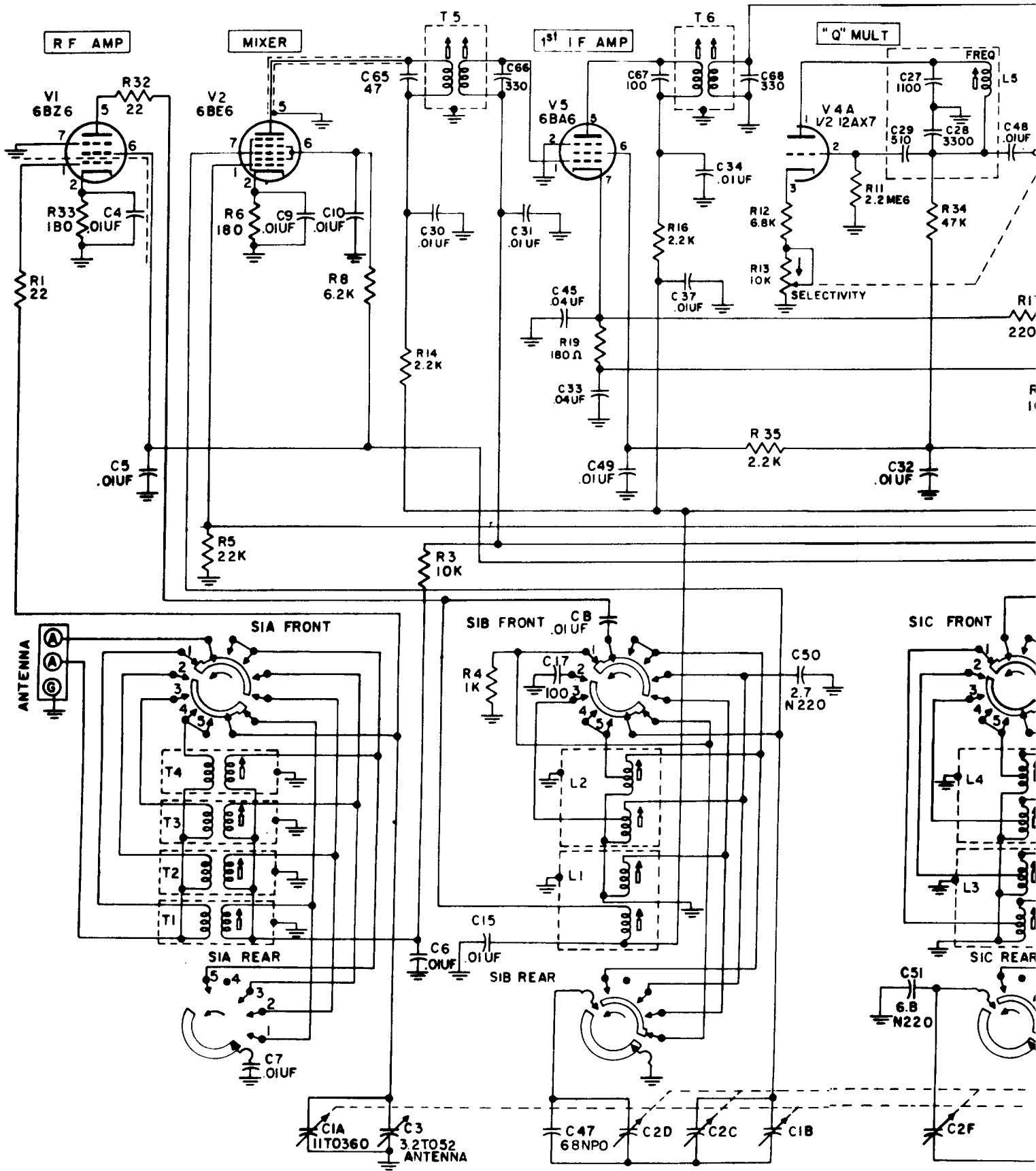

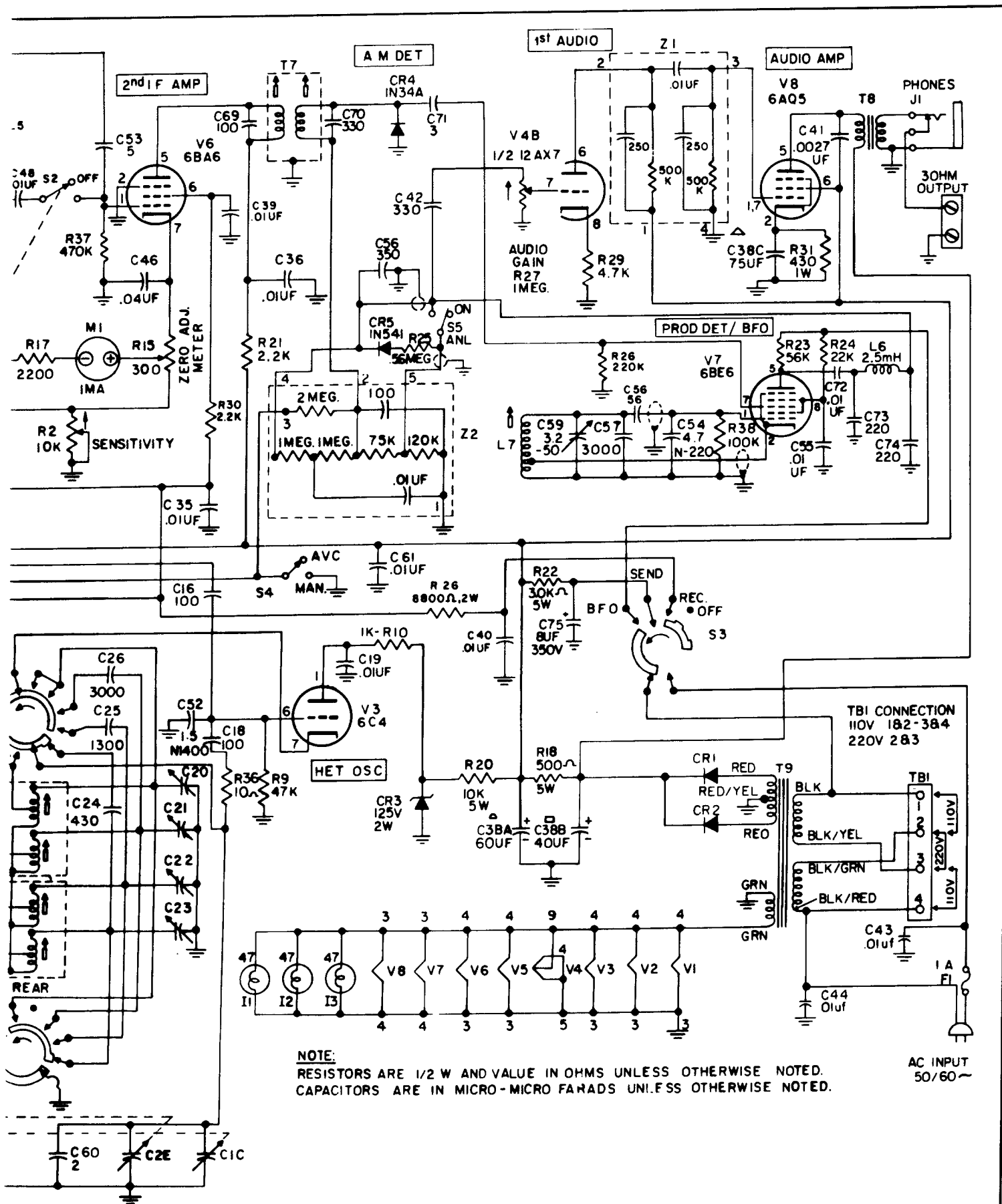

FIGURE 6-1. HQ 200 SCHEMATIC DIAGRAM.