

# BANDMASTER AMATEUR TRANSMITTERS

BANDMASTER, JR.

MODEL TBS-50B

BANDMASTER, SENIOR

MODEL TBS-50C

BANDMASTER, DELUXE

MODEL TBS-50D



HARVEY-WELLS ELECTRONICS, INC.  
SOUTHBRIDGE, MASS., U.S.A.

HARVEY-WELLS ELECTRONICS, INC.

BANDMASTER SERIES AMATEUR TRANSMITTERS  
 MODELS TBS-50B, TBS-50C, AND TBS-50D

INSTRUCTION MANUAL: TABLE OF CONTENTS

	Page
General.....	2
Technical Characteristics - TBS-50B, TBS-50C, and TBS-50D.....	2
Frequencies.....	2
Microphones.....	3
Output Coupling.....	3
Front Panel Controls.....	3
Technical Characteristics of Power Supplies.....	4
Installation.....	4
Operation of TBS-50 with VFO.....	8
Keying VFO.....	9
Antennas.....	10
Exciter Operation.....	13
Service Notes.....	15
General.....	15
Check Voltages for TBS-50.....	16
Operation of TBS-50 Into 8' Vertical Antenna on 3.9 Mc.....	16
Operation of TBS-50 on 2374 Kc. and 148.14 Mc. for C.A.A. use.....	17
Operation of TBS-50 From PE-103 Dynamotor.....	18
Modifications Required for Operation of TBS-50 on 1.8 Mc.....	19

LIST OF ILLUSTRATIONS

Figure	Description	Page
Frontispiece	Front View TBS-50.....	1
1	Back Terminal Schematic for use with APS-50.....	5
2	Back Terminal Schematic for use with DPS-5006 and VPS-5006.....	5
3	Back Terminal Schematic for use with DPS-5012.....	6
4	Back Terminal Schematic for Exciter Service.....	6
5	VFO Feed.....	9
6	VFO Link Feed.....	9
7	Antenna Matching Circuits.....	10
8	Half Wave Antenna.....	11
9	300 Ohm Twin Lead Feeder.....	12
10	Typical Feeder/Antenna for 29 Mc.....	13
11	Exciter Feeding Schematics.....	14
12	Vertical Car Antenna Schematic.....	17
13	Antenna Coupling for 1.8 Mc. Operation.....	20
14	Antenna System for 1.8 Mc. Operation.....	21
15	Right Side View TBS-50.....	22
16	Left Side View TBS-50.....	23
17	Schematic APS-50 Power Supply.....	24
18	Schematic DPS-50 Power Supply.....	25
19	Schematic VPS-50 Power Supply.....	26
20	Schematic TBS-50B.....	27
21	Schematic TBS-50C.....	28
22	Schematic TBS-50D.....	29

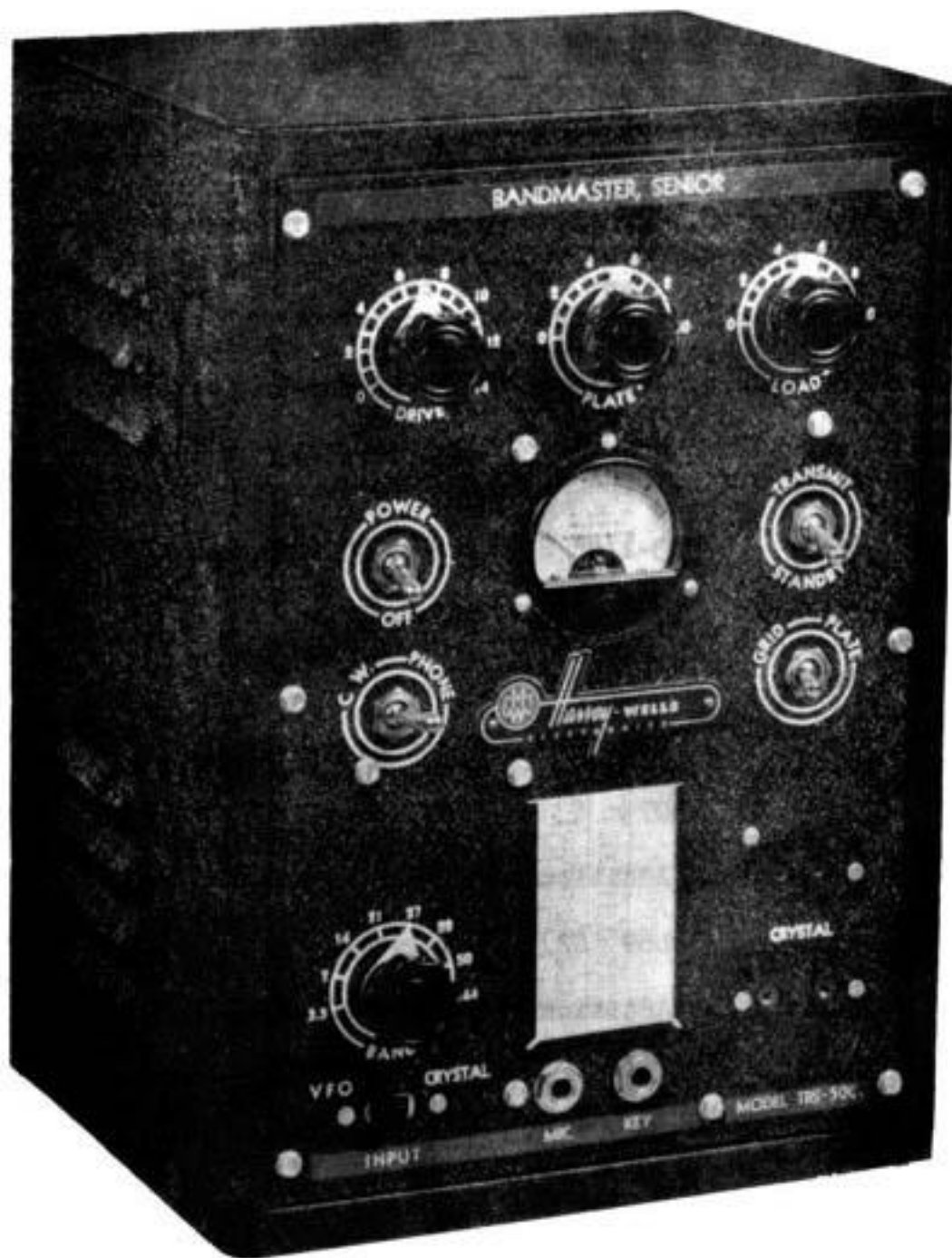

HARVEY-WELLS  
EIGHT BAND AMATEUR TRANSMITTER  
MODEL TBS-50C  
FRONT VIEW

HARVEY-WELLS ELECTRONICS, INC.

INSTRUCTION MANUAL AMATEUR TRANSMITTER

MODELS TBS-50B, TBS-50C AND TBS-50D

GENERAL

The TBS-50 is a versatile general purpose PHONE/CW transmitter capable of delivering RF power on all amateur frequencies from 3.5 mc. to and including 14.8 mc. It may be used with any plate voltage up to 450 volts and the tube heaters may be operated from either 6 or 12 volts. Dynamotor and vibrator power supplies are available for portable/mobile operation, and an AC power supply for fixed station equipment. Three transmitter models are available, TBS-50B for C.W. only, the TBS-50C for carbon microphones, the TBS-50D with a built-in, three tube preamplifier for crystal or high impedance dynamic microphones. These are improved models of the original TBS-50 and TBS-50A.

TECHNICAL CHARACTERISTICS - TBS-50B, TBS-50C, TBS-50D TRANSMITTERS

Size: 13-1/4" High x 9-1/4" Wide x 8-1/2" Deep

Weight: 17 Pounds

Tubes: TBS-50B

6AQ5	Oscillator/multiplier
6AQ5	Multiplier
807	Final Amplifier

Tubes: (Additional in TBS-50C and TBS-50D)

6L6G (2) Modulators

Tubes: (Additional in TBS-50D Only)

6AU6	1st Speech Amplifier
6AU6	2nd Speech Amplifier
12AU7	Phase Inverter

FREQUENCIES

Output	Crystal
3500	3500
4000	4000
7000	3500
7300	3650
14000	3500
14400	3600

## FREQUENCIES (Continued)

Output	Crystal
21000	3500
21450	3575
26960	6740
27230	6807.5
28000	7000
29700	7425
50000	5555.5
54000	6000
144000	8000
148000	8222

## MICROPHONES

- TBS-50C Single button, high gain, carbon, 200 ohms.  
(The conventional telephone handset microphone works very well. Surplus handsets TS-13, HS-23 and TS-11 contain microphones that will adequately modulate the TBS-50.)
- TBS-50D Crystal or high impedance dynamic at -50 db approximately.

## OUTPUT COUPLING

Simplified pi type designed for non-reactive antennas or feeders between 50 ohms and 500 ohms.

## FRONT PANEL CONTROLS

- BAND switch, for selecting proper band
- DRIVE, for adjusting grid excitation to 807
- PLATE, 807 plate tank
- LOAD, antenna loading adjustment
- POWER/OFF switch, wired to control input to power supply
- TRANSMIT/STANDBY switch, wired to control output of power supply
- CW/PHONE switch for A-1 or A-3
- GRID/PLATE meter switch
- CRYSTAL sockets for 3/32 dia. pins on 1/2 centers, or 1/8 dia. pins on 3/4 centers
- INPUT control switch, for shorting cathode choke of oscillator for VFO operation

TECHNICAL CHARACTERISTICS - APS-50, DPS-50, AND VPS-50 POWER SUPPLIES

	DPS-5006	DPS-5012
Size:	5 3/4"H x 9 1/2"W x 5 1/4"D	9"H x 12"W x 6 1/2"D
Weight:	15 lbs.	26 lbs.
Input:	6 V DC.	12V DC.
Output:	300V. ● 250 ma.	400V. ● 250 ma.
	APS-50	VPS-5006
Size:	7"H x 11"W x 8"D	5 1/2"H x 8 1/2"W x 7"D
Weight:	22 lbs.	7 1/2 lbs.
Input:	115V. 50-60 cy.AC	6 V. DC.
Output:	HI. 425V. ● 275 ma. LO. 300V. ● 275 ma.	275-300V. ● 250 ma.

INSTALLATION

There are two terminal strips provided at the rear of the TBS-50 so that connections may be made to cover a wide variety of operating conditions. Reference to the schematic wiring diagram will show how these terminal strips are connected into the circuit; the following details will cover a few of the possible combinations. All views are looking at the rear of the transmitter; terminal #1 is at the upper left, terminal #14 is at the lower right.

Assuming the TBS-50 is to be operated as a complete transmitter, connect the terminal strips as in Figures 1, 2, or 3 depending upon the type of power supply used. Connect the power cord from the power supply to the chassis connector at the rear of the TBS-50. The transmitter and power supply may now be controlled by the front panel POWER/OFF and TRANSMIT/STANDBY switches.

In case it is desired to construct a power supply, the voltages and currents should approximate those as shown on the circuit diagram of the APS-50 Figure 17. A female power connector is supplied with the TBS-50 and this should be connected to the power source as indicated on the schematic diagram with the high voltage connected between pins 1 and 7 and the heater voltage between pins 2 and 7. Toggle switch leads are brought to pins 4 and 5 and these may be connected in series with the primary AC to the power source, also the leads brought to pins 3 and 6 may be used to control the AC to the plate transformer.



FOR NORMAL PHONE/CW OPERATION  
 WITH  
 AC POWER SUPPLY TYPE APS-50  
 (425V POWER SUPPLY 6V ON HEATERS)

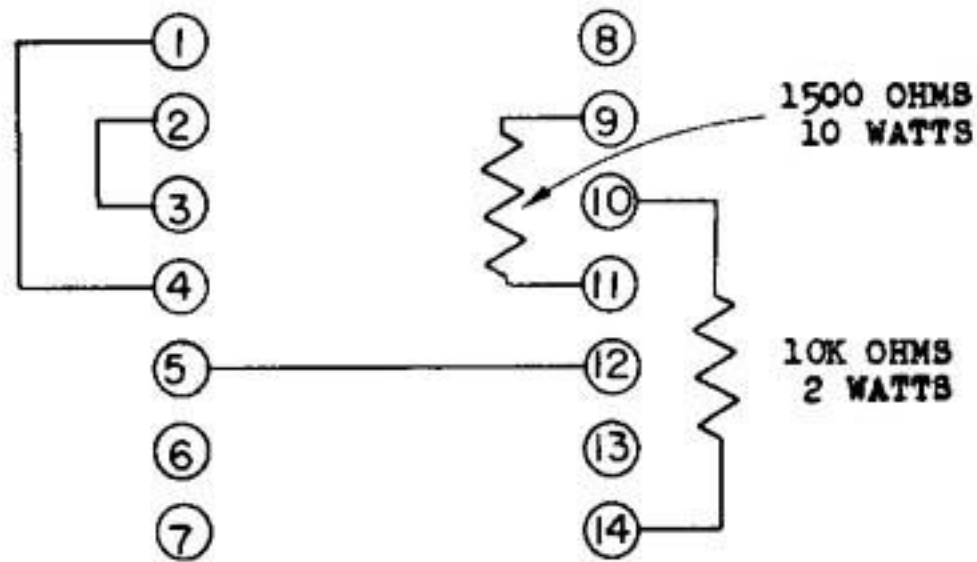

Figure 1.

FOR NORMAL PHONE/CW OPERATION  
 WITH  
 6V DYNAMOTOR SUPPLY TYPE DPS-5006 OR 6V VIBRATOR SUPPLY  
 TYPE VPS-5006  
 (300V POWER SUPPLY AND 6V ON HEATERS)

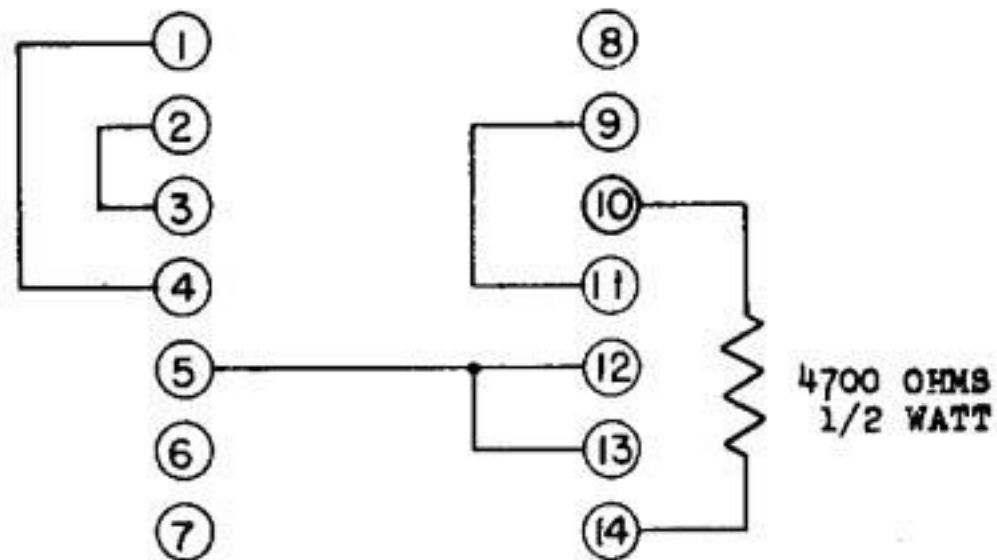
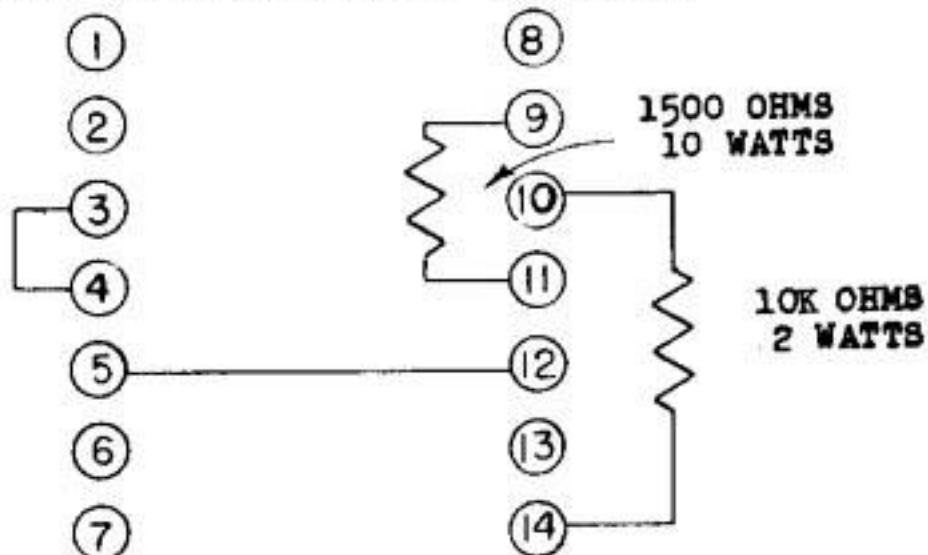

Figure 2.

**FOR NORMAL PHONE/CW OPERATION  
WITH  
12V DYNAMOTOR POWER SUPPLY TYPE DPS-5012  
(400V POWER SUPPLY AND 12V ON HEATERS)**



**Note:** Terminals 1, 2, 3 and 4 may be connected as in Figure 2 for 6V heater operation.

Figure 3.

**FOR EXCITER SERVICE  
(MODULATION REMOVED FROM 807 PLATE),  
400V POWER SUPPLY 6V ON HEATERS**

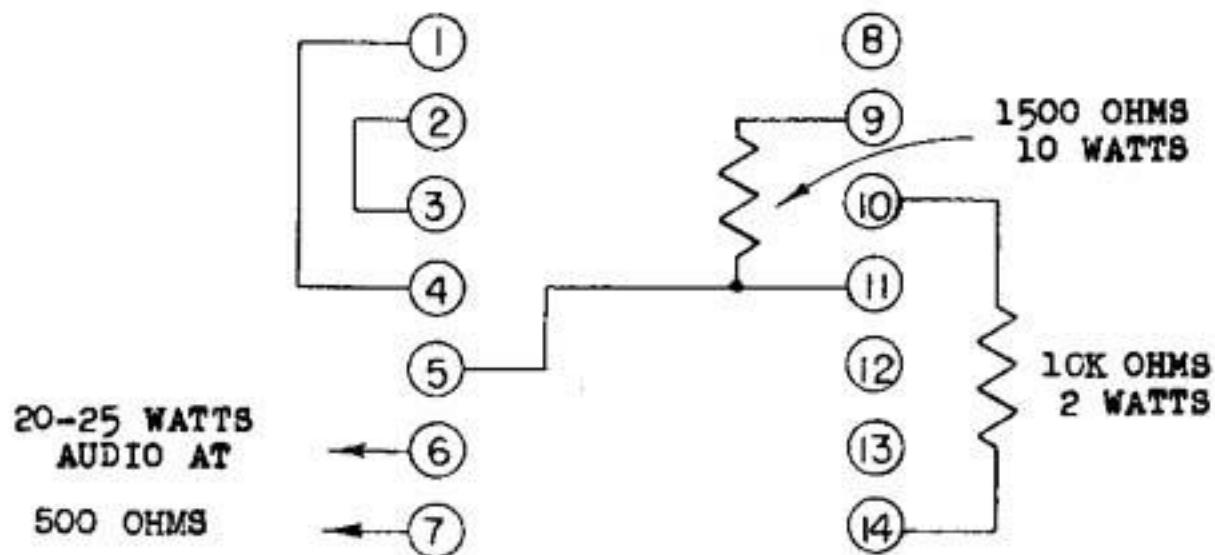

**Note:** Leave PHONE/CW switch in PHONE position.

Figure 4.



A three contact microphone jack is used with a lead brought out to pin 8 so that, if desired, a push-to-talk circuit may be easily wired in.

NOTE: When using a two contact plug, the microphone connection to the ring contact of the jack must be changed to the tip contact of the jack for proper operation of the microphone.

With all connections made and voltage applied to the tube heaters, the transmitter is ready for operation.

All circuits of the TBS-50 except those associated with the 807 plate and the antenna for all bands except 50 and 144 mc. are pre-tuned at the factory and require no further adjustment for any frequency within the bands. A later paragraph will describe the tuning of these two high frequency bands.

Some antenna and feeder systems on 3.5 and 7 mc. will require an external variable receiving type condenser connected between the antenna post and the chassis ground. It will be well to connect in such a condenser having a maximum value of .0005 mfd. (500 mmf.) or .001 mfd. (1000 mmf.) in case the antenna does require it. It will be impossible to resonate the 807 plate circuit on 3.5 and 7.0 mc. without an antenna unless this external condenser is used. Set the BAND switch to 3.5, the load to 10, (maximum capacity), the external load condenser to maximum capacity, the DRIVE to 14 or maximum, the emission toggle to PHONE and the meter toggle to GRID. With a crystal of the correct frequency plugged into the crystal socket, and the INPUT control switch set towards CRYSTAL, apply plate voltage and note that the meter reads grid current to the 807. Turn the meter switch to PLATE and quickly tune the PLATE condenser to resonance. Now with the antenna connected rotate the external load condenser to minimum and the LOAD condenser if necessary, all the time keeping the PLATE condenser tuned to resonance until the 807 is loaded to maximum output preferably as indicated by an RF ammeter in series with the antenna or feeder. The 807 plate current should be about 100 ma. At this time turn the meter switch to GRID and adjust the DRIVE for maximum output, usually resulting in a grid current of about 1.5 to 2.0 ma. At this point the transmitter is ready to be modulated if a phone crystal is being used, or a key may be plugged into the key jack and the emission switch set for CW. All stages are keyed including the crystal so that break-in operation is possible. On the TBS-50D a hole is provided on the right hand side of the cabinet thru which the gain control may be adjusted for proper modulation.

Operation on the first six bands (3.5 thru 28 mc.) is exactly as described above, being careful to use the proper fundamental crystal in accordance with the card on the front panel. The frequencies of the various tuned circuits are shown in the table on the circuit diagram, and the tuning is sufficiently broad to cover the entire band necessitating no crystal or multiplier circuit tuning. On the 50-54 mc. band however, these circuits must be tuned if end of band operation is desired.

The set is factory tuned with a 5750 kc. crystal and crystals in this vicinity resulting in a carrier frequency of about 52 mc. may be used without retuning. If end of band operation is desired, select the proper crystal, and with power on, and the DRIVE control at maximum adjust the small mica compression trimmer, Figure 16, and multiplier coil L9, Figure 15, for maximum grid current. Operation over a small frequency range may then be had by plugging in crystals; as long as it is possible to secure approximately 1.5 ma. of grid current it will be unnecessary to retune the preliminary circuits.

Operation on the 144 mc. band requires certain considerations. Because the 807 tube doubles to this band and because it is outside the normal range of the tube, the plate efficiency is very low and for this reason the plate voltage must be limited to 300 volts in order not to exceed the plate dissipation of the tube. The terminal strips should therefore be connected in accordance with Figure 2, and the HI-LO switch set to LO if the APS-50 power supply is used. As in the preceding paragraph the transmitter is factory tuned with an 8100 kc. crystal for operation on about 146 mc. With a crystal in this vicinity the 807 grid current should be about 2 ma. and a flashlight bulb connected to one or two turns of wire 1/2" in diameter and coupled to the small coil in the 807 plate lead should light. No particular dip will be noticed in the plate current as the PLATE condenser is tuned, but it should be tuned for greatest brilliancy of the bulb. A separate antenna connector is provided for this band, and a self-supporting antenna or a low impedance feeder may be connected to it thru the hole provided in the top of the cabinet. On this band the LOAD condenser will have no effect; loading should be adjusted by varying coupling coil.

If end of band operation is desired on this band, coils L3 and L10 must be adjusted for maximum grid current. Note that L3 and L10 are also used on the 50-54 mc. band; therefore, after any tuning of the 144-148 mc. band, adjustments must be made to the mica compression condenser and the L9 as discussed above.

NOTE: On the 50 and 144 mc. bands some crystals will "sing" due to regeneration. If this occurs detune L3 very slightly (if 144 mc.) or detune the mica compression condenser very slightly (if 50 mc.)

NOTE: Because all circuits are tuned only with tube and circuit capacities, variations in 6AQ5 tubes may give trouble because of a change in inter-electrode capacities. The circuit values were chosen to operate with either RCA or GE 6AQ5 tubes. In case of trouble in securing grid current particularly on the higher frequencies, with other make tubes, change to either RCA or GE brand.

#### OPERATION OF TBS-50 WITH A VFO

The TBS-50 may be driven by a VFO providing the output voltage is at least as high as that obtained from an active crystal.

The INPUT control switch should be set on VFO to eliminate any tendency of self-oscillation in the TBS-50.

The usual method of feed is from the plate of the last tube in the VFO into the TBS-50 crystal socket, as shown in Figure 5. Be sure that a blocking condenser is used and that the ground connects to the outside crystal socket pin.

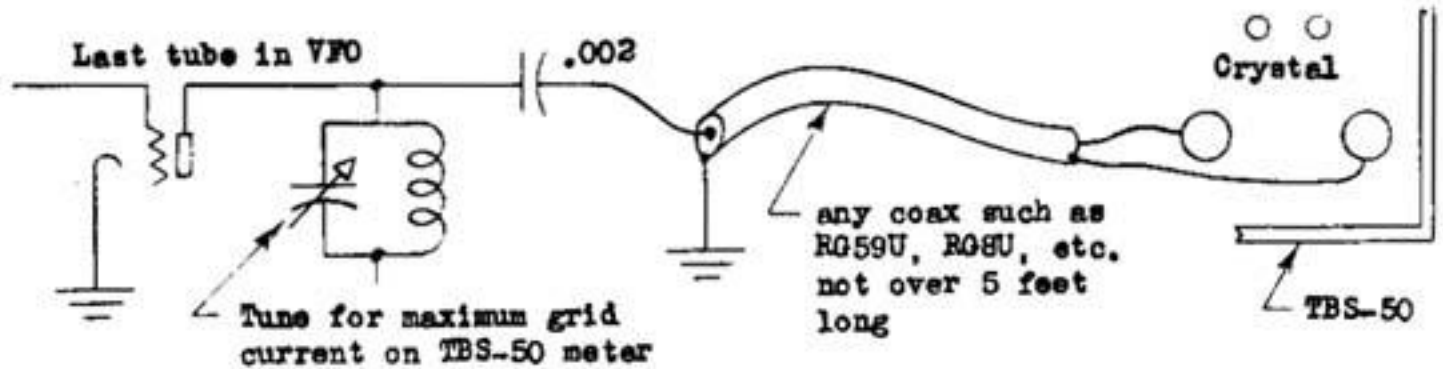

Figure 5.

If the output from the VFO is a low impedance link, the chances are that there will be insufficient voltage available so a supplementary tuned circuit will have to be used as shown in Figure 6. The link line may be of any reasonable length. See any amateur handbook for coil and condenser values.

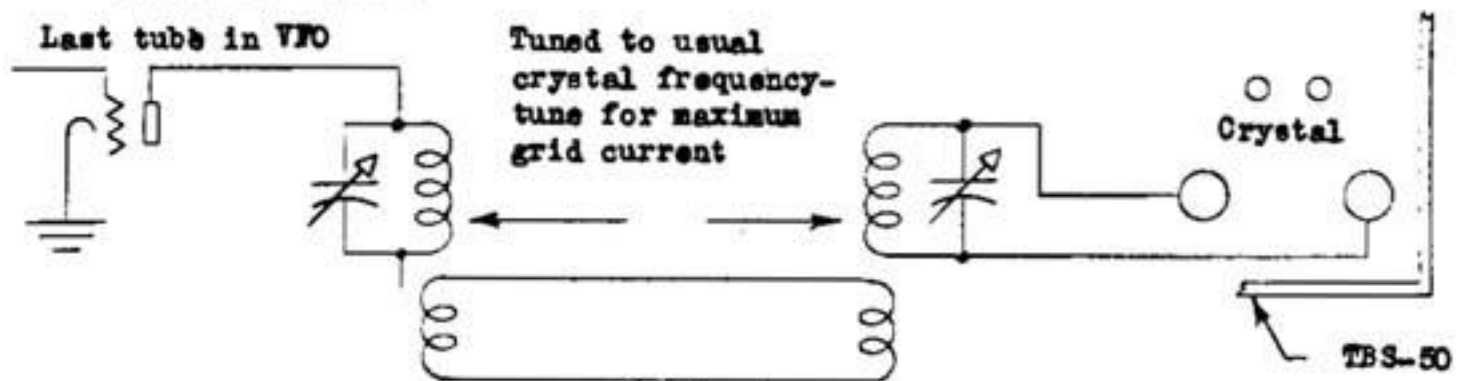
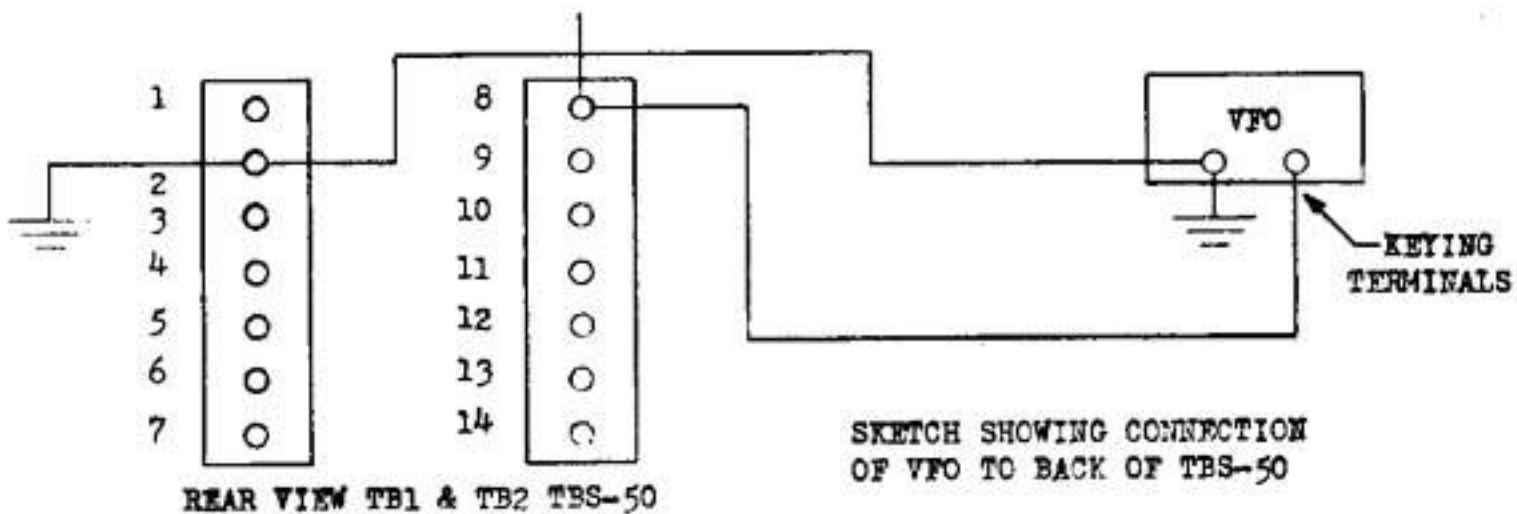

Figure 6.

It is recommended that the output frequency of the VFO be the same as the crystal which it replaces as shown by the chart on the front of the TBS-50.

If it is desired to key the VFO when keying the transmitter, the circuit in the VFO which is to be keyed, one side of which must be ground, can be connected between pin #8 and pin #2 of the terminal strips on the back of the TBS-50. When the key is closed, pin #8 will be connected to pin #2 thru ground.



### ANTENNAS

Much could be written regarding types of antennas for the amateur bands as evidenced by the antenna sections of the amateur handbooks such as that published by the ARRL to which the reader is referred. The TBS-50 was designed to work into any non-reactive load between 50 and 500 ohms, but actually will load into a wide variety of antenna systems. As the output is unbalanced, that is one antenna and one ground lead, it will not work satisfactorily into a balanced system such as parallel wire tuned or untuned feeders without an external matching circuit such as those shown in Figure 7.

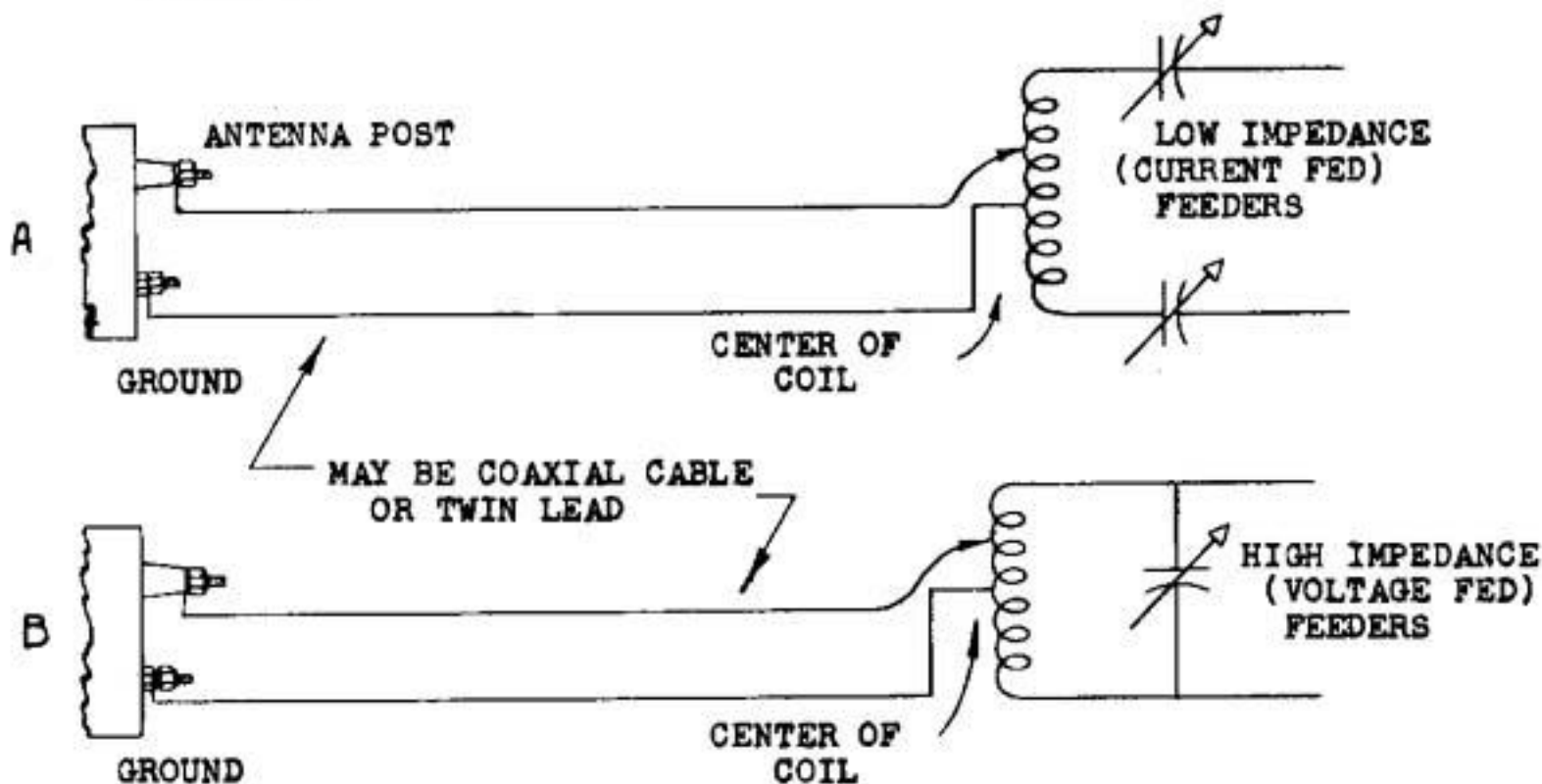

Figure 7.

For a tuned current fed feeder system use Figure 7A, for an untuned line or a tuned voltage fed feeder use Figure 7B. The coil and condenser or the net capacity of the two condensers in series must resonate to the operating frequency.



The TBS-50 works nicely into a single wire feeder or into a coaxial feeder such as RG8/U or RG11/U. These are untuned feeders and may be any length. The length of a half-wave antenna may be calculated from the formula

$$L \text{ in feet} = \frac{468}{f_{mc}}$$

For a single #12 wire feeder the distance from the center at which it connects to the antenna is 0.133 times the length.

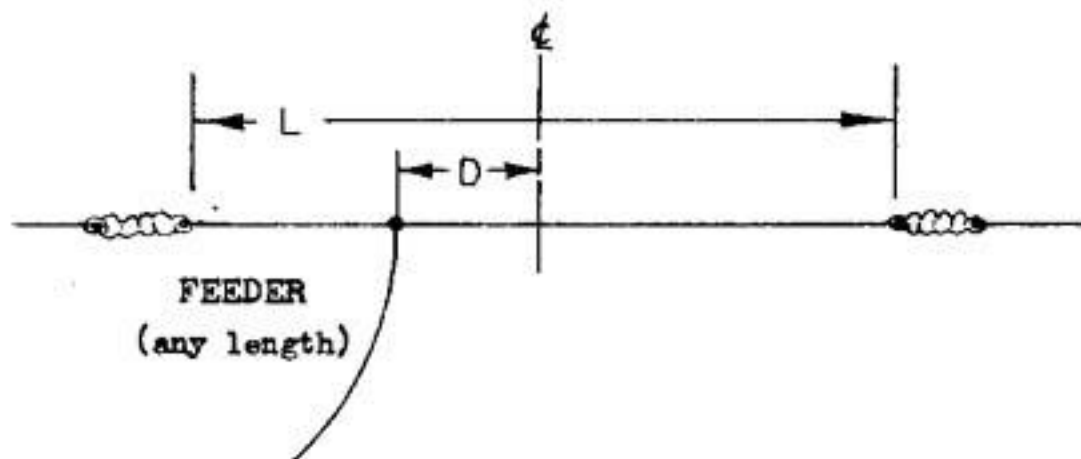

Figure 8.

For an operating frequency of 3600 kc.

$$L = 130'$$

$$D = 17' 4''$$

The length of a simple half-wave antenna center fed with low impedance coaxial feeder may be figured from the above formula and for 14.2 mc. is 33 feet.

A simple way of feeding a 300 ohm twin lead feeder on the higher frequencies makes use of a length of RG11/U acting as a transformer connected as follows:

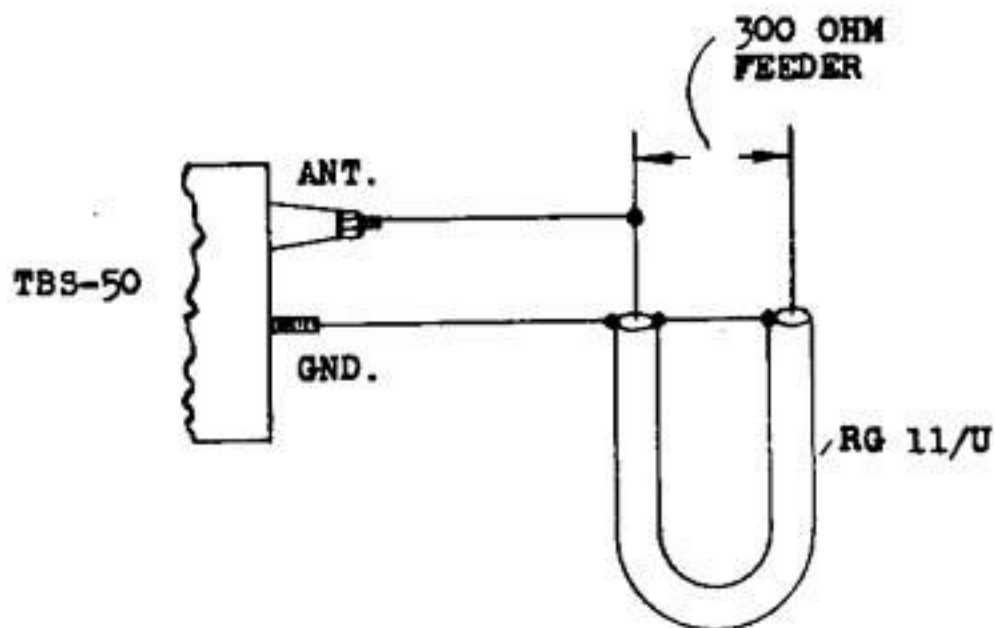

Figure 9.

As the RG11/U acts as a transformer, its length is critical and may be calculated from the following formula:

$$\frac{3900}{f_{mc}} = \text{length in inches}$$

This is the length of cable to be used; the ends may be stripped 1/2 inch or so for making connections. The transformer may be connected directly to the TBS-50 with short leads, or RG11/U cable, any length, may be used.

If the 300 ohm feeder is used to feed a length of 300 ohm twin-lead as a folded dipole, the length of the flat-top may be calculated from the following:

$$\frac{5730}{f_{mc}} = \text{length of flat-top in inches}$$

A typical feeder/antenna cut for 29 mc. which should give good results over the entire band is sketched on the following page in Figure 10.

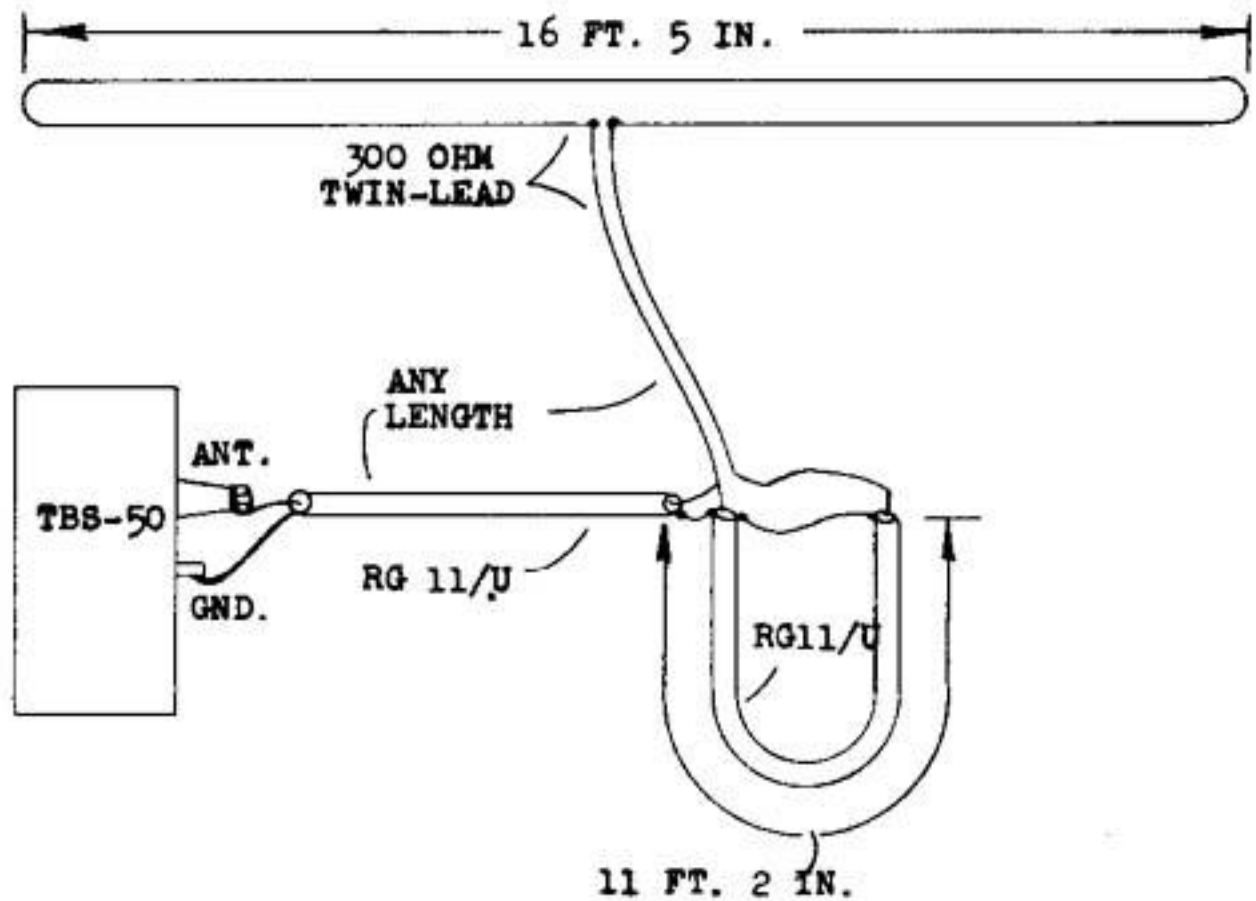

Figure 10.

#### EXCITER OPERATION

The TBS-50 may be used to drive a higher powered amplifier arranged for either push-pull or single ended operation.

Any types of tubes may be used, triodes or pentodes as long as the driving requirement does not exceed 20-25 watts.

Three suggested ways of feeding the higher powered stage are shown in the following sketches.



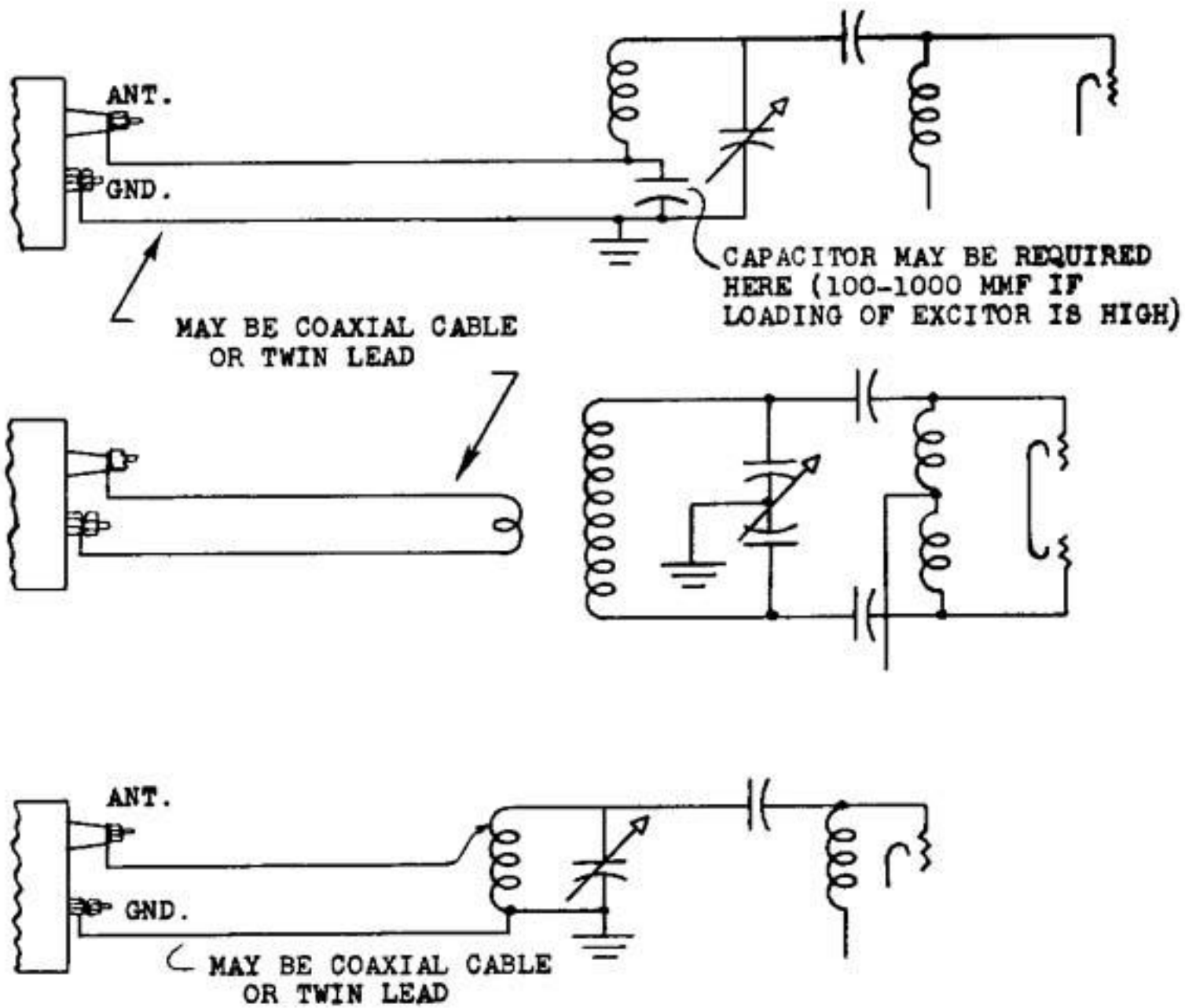

Figure 11.

The 6L6 modulators may be used to drive a higher powered Class B stage using the audio power available (See Figure 4). The output impedance is 500 ohms and a transformer from 500 ohms to push pull grids should be used to the modulator tubes.

## SERVICE NOTES

### GENERAL

Good active crystals must be used with the TBS-50. The crystal oscillator circuit is somewhat regenerative and if weak crystals are used self-oscillation may occur which may result in off frequency operation. If in doubt, tune a nearby receiver to the transmitting frequency. If it is not a pure steady crystal controlled signal, the probability is that the crystal is weak and is not controlling the frequency. Since the TBS-50 is keyed in the oscillator circuit for break-in operation, a weak crystal may not follow the keying properly. Response of poor crystals can in some cases be improved by connecting a small capacitor (approximately 50 mmf) from pin 7 (grid) of V1 (6AQ5) to the CRYSTAL side of SW9 (INPUT switch). (Shown in dotted lines on schematic diagrams). This will provide feedback capacity to improve crystal activity.

Before putting the transmitter on the air, it is a good idea to become familiar with its operation using a dummy load. This load may be an ordinary 60 watt 115 V lamp bulb connected directly from antenna post to ground. With this bulb the loading operation can be checked and the actual modulation observed. On the lower frequencies, a condenser will have to be connected in parallel with the load circuit as described on page 7.

With some transmitter installations on certain frequency bands, RF feedback may occur. On the higher frequencies where the ground wire is often at least 1/2 wavelength long, and therefore does not ground the transmitter to RF, connecting the transmitter ground post to any large nearby metallic object such as a file cabinet, metal table, etc. will usually eliminate the feedback.

If a push-to-talk microphone is used with the TBS-50C or TBS-50D the relay actuated by the microphone switch should be DC operated to avoid any AC in the microphone ground lead which might cause hum on the carrier.

The TBS-50C may be converted to a TBS-50D at any time by adding the crystal microphone preamplifier (Model CMA-50), mounting holes for which are already punched in the chassis. A detailed instruction sheet is provided with each amplifier showing how to install and connect it to the transmitter.

The TBS-50B may be converted to either a TBS-50C or a TBS-50D at any time. All the necessary mounting holes are already punched in the chassis. Complete Harvey-Wells kits are obtainable containing all the necessary parts with a detailed instruction sheet showing how to install and connect the parts to the transmitter. The TBS-50B is already wired to be converted to a TBS-50C and all that is necessary is to mount and connect the parts contained in the kit.

NOTE: The unsoldered wires in the TBS-50B are the wires used in changing TBS-50B to TBS-50C.

#### CHECK VOLTAGES FOR TBS-50

The following voltages in Table I below are average voltage figures and will vary slightly in various production runs. The voltages were read with a multimeter having an input resistance of 20,000 ohms per volt. Inasmuch as some of these voltages depend upon actual operating conditions, when making measurements be sure all conditions are as stated below:

Frequency - 28 mc.  
Power Supply - APS-50  
Drive full on  
Switch position high  
Fully loaded by real or dummy antenna  
Phone position - No modulation  
Input switch towards crystal  
Rear terminal connections as in Figure 1

<u>Tube</u>	<u>Voltage</u>
6AQ5 Osc. cathode	13.5
6AQ5 Osc. screen	213
6AQ5 Osc. plate	*270
6AQ5 Doubler screen	240
6AQ5 Doubler plate	*310
6AQ5 Doubler cathode	14.75
807 Screen	295
807 Plate	*425
2-6L6 Screen	380
2-6L6 Plates	420
2-6L6 Cathode	30.5

\* Measured thru 45 ohm 2.5 mh choke

#### OPERATION OF TBS-50 INTO 8' VERTICAL CAR ANTENNA ON 3.9 MC.

The TBS-50 may easily be loaded into a short vertical car antenna on lower frequency bands providing the right procedure is followed. In mounting the antenna and arranging the feed-thru insulator on the car, take care to keep the capacity to ground as low as possible, as this will govern to a large degree the radiating efficiency of the antenna.

A large load coil is necessary, preferably air wound so that a connection can be made to any turn. This coil should be about 100-200 microhenries in inductance, the actual value depending upon the actual capacity of the antenna, its base mount, and the capacity of the lead-in wire. The coil must be large enough to resonate with the total of the above capacities to the operating frequency. One suitable air wound coil for 3.9 mc. would be 4" diameter, 6" long wound 10 turns per inch.

Mount the coil well away from the car body, and connect the bottom of the coil electrically to the car chassis. Connect the antenna by a suitable clip to the top of the coil. Connect the ground post of the TBS-50 to the car chassis, and the antenna post by a suitable clip to the coil about half way up. Connect a small neon bulb to the antenna to serve as a tuning indicator.

With the TBS-50 tuned up properly and the LOAD condenser set for full capacity, vary the position of the two taps until the neon bulb lights brightest without exceeding the maximum loading of the 807 tube. After every adjustment reresonate the PLATE condenser.

It may be necessary to add an external condenser of 250-500 mmf between antenna and ground leads of the TBS-50 if any difficulty is experienced with too heavy loading.

Properly loaded there should be lots of "fire" on the antenna when touched with a pencil.

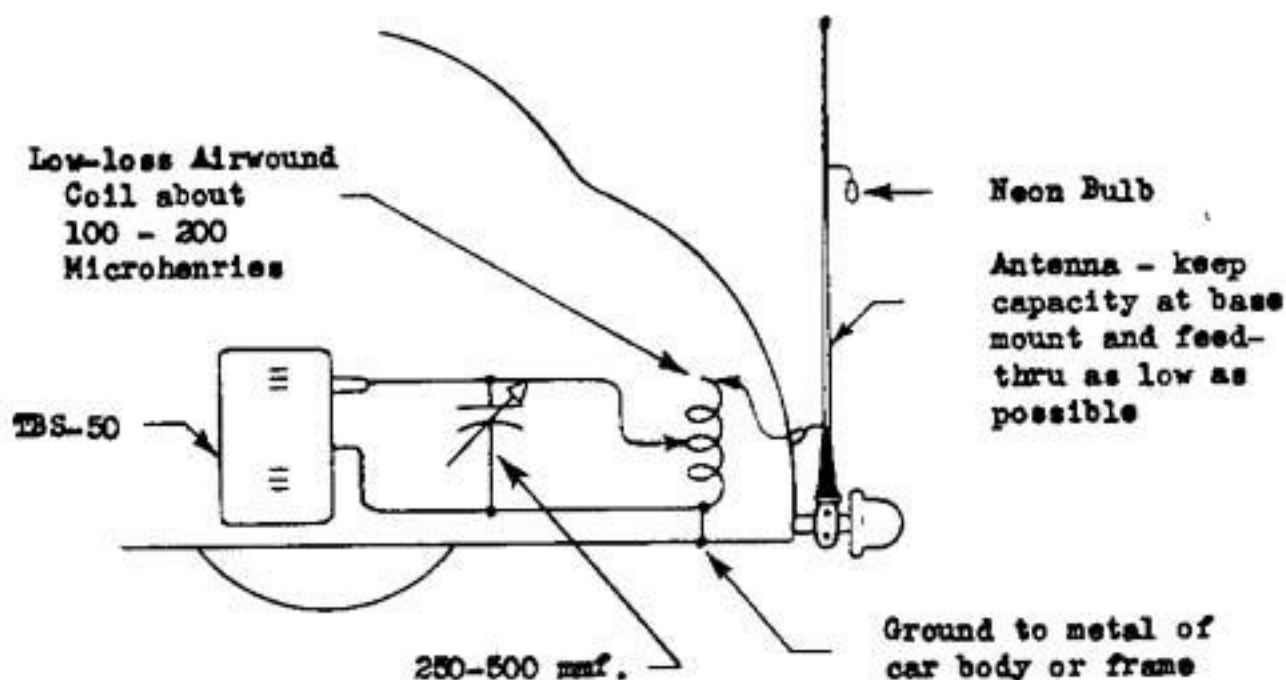

Figure 12.

#### OPERATION OF TBS-50 ON 2374 KC AND 148.14 MC FOR C.A.P. USE

Much interest has been shown regarding the possibility of modifying the TBS-50 transmitter to work on the two special frequencies of 2374 kc. and 148.14 mc. allocated to the Civil Air Patrol.

Operation on 148.14 mc. should require nothing other than careful tuning of the multiplier circuit coils L3 and L10 as explained elsewhere in the instruction book. This procedure will be facilitated if a receiver with an S meter is tuned to the proper harmonic, tuning being done for highest meter reading.

Circuit additions are necessary for 2374 kc. operation and are described below.

(1) Connect a 50 mmf. silver mica condenser (Cornell Type 5B or equivalent) across coil L4. This tunes it to 2374 kc.

(2) Connect a 300 mmf. mica condenser (Cornell Type 4 or Type 9 or equivalent) in parallel with C15. This makes total capacity of 450 mmf.

(3) Connect a large condenser, or two or more condensers in parallel totalling about .003 mfd. directly from the antenna post to the ground post. At least .001 mfd. of this should be variable as this is the new LOAD condenser used in conjunction with the front panel LOAD condenser to load the antenna. The .001 mfd. variable capacitor may be a 3 gang receiving type with all sections connected in parallel. The remaining .002 mfd. may be mica (Cornell Type 4 or Type 9 or equivalent).

The transmitter may now be connected to an antenna and the TUNE and LOAD condensers, including the external one, adjusted for greatest antenna current. The antenna may consist of a random length of wire worked against ground or may be a 1/2 wave flat top with a single wire feeder.

#### Notes:

In case trouble is experienced with too little or too much antenna loading, use more or less capacity than the .003 mfd. above.

Tune a nearby receiver to 2374 kc. to make sure the crystal is oscillating, in case no grid excitation is obtained.

A 60 watt 115 volt lamp bulb can be used as a dummy antenna to check operation of the transmitter.

#### OPERATION OF TBS-50 FROM PE-103 DYNAMOTOR

We have had many requests for information concerning the suitability of the surplus dynamotor PE-103 for powering the TBS-50, TBS-50A, TBS-50C, or TBS-50D in mobile operation. Although this dynamotor is rated at 500 volts and 160 ma. and is overloaded if called upon to deliver the 250 ma. required by the TBS-50, it will operate satisfactorily if certain precautions are observed and if the possibility of burn-out is overlooked or discounted.

If the TBS-50 is operated on phone fully loaded, from the PE-103, the 250 ma. current drain will reduce the voltage to about



425 volts, which is correct, provided that no greater than 6.0 volts is applied to the dynamotor leads (when set for 6V operations).

Therefore:

- (1) Always leave switch in PHONE position.
- (2) Always operate TBS-50 loaded.
- (3) Never operate CW.
- (4) Never operate unloaded.
- (5) Never allow dynamotor input to exceed 6.0 volts.
- (6) Never use with TBS-50B.

Failure to heed these precautions will probably result in burned out coils, and damaged components due to too high plate voltage, and these will not be replaced without charge.

#### MODIFICATIONS REQUIRED FOR OPERATION OF TBS-50 ON 1.8 MC.

There are three points which must be considered in making these modifications and they are as follows:

1. Tuning L4 to 1.8 mc. This can be done by soldering a capacity of about 100 mmf. to the terminals of L4. This capacity should be made up of a fixed condenser of approximately 80 mmf. in parallel with a mica compression type of 3 - 30 mmf.

2. Resonating the final 807. This can be done by connecting an external plate coil of approximately 15 microhenries from antenna to ground post. This coil can be about 15 turns of #18 D C C wire close wound on a 2" diameter form.

3. Resonating the antenna. Since the average antenna will be worked against ground at 1.8 mc., the best way to couple to it is with a coupling coil tuned with a series condenser. This coil can be about the size of the external plate coil, but should be wound on a larger or smaller form so that it can be slid over into the plate coil for coupling purposes.

Figure 13.

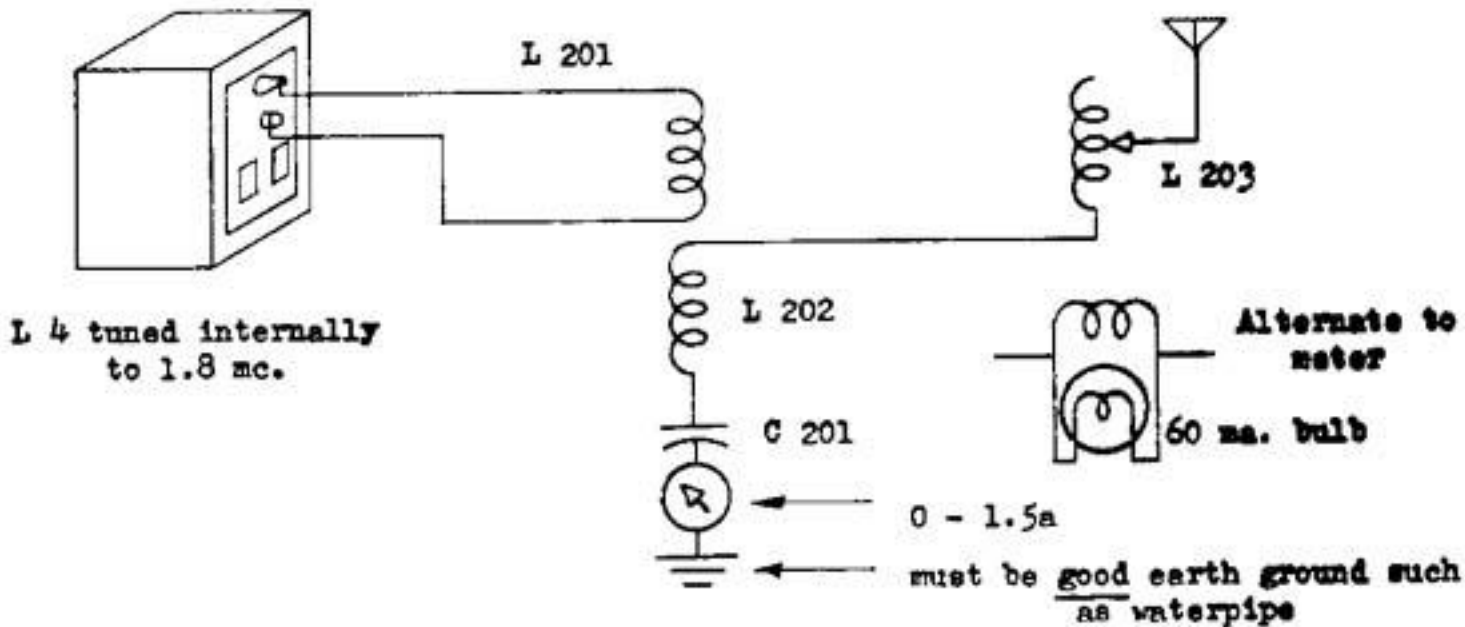

- L 201 15 turns #18 D C C close wound on 2" form.  
 L 202 15 turns #18 D C C close wound on 2 1/2" form.  
 L 203 60 turns #18 D C C close wound on 2" form tapped every 5 turns.  
 C-201 500 - 1000 mmf.

With the TBS-50 modified as above and connected as shown in Figure 13, set the band switch to 3.5, plug in a 1.8 mc. crystal, and with power on, tune the condenser across L4 until the crystal oscillates stably and 807 grid current is obtained. Next, set the LOAD condenser to zero and use the PLATE condenser to tune for minimum dip on the plate meter. Set the DRIVE for about 2 ma. of grid current. Until the load is connected to the final amplifier, the crystal may not start every time. If this is the case, detune L4 and/or the final tank circuit until the crystal is stable.

Connect up the antenna circuit as shown in Figure 13. The series condenser can be a three gang broadcast type with all sections in parallel. If no RF ammeter is available, use a 60 ma. pilot bulb shunted by a few turns of #18 copper wire.

A good ground must be used as this carries as much RF as the antenna, and a connection to a water pipe or some other system of underground conductors is recommended. Unless the antenna consists of a straight length of wire 125 ft. or so in length it is probable a loading coil will be required in series with the antenna, connected as shown in Figure 13.

With the transmitter operating, tune the antenna series condenser and adjust the coupling of the antenna coil so that the



antenna current is highest with a resonant 807 plate current of 100 ma. or so.

A good earth ground is a must and is as important as the antenna system.

#### Suggested Antenna Systems for 1.8 Mc.

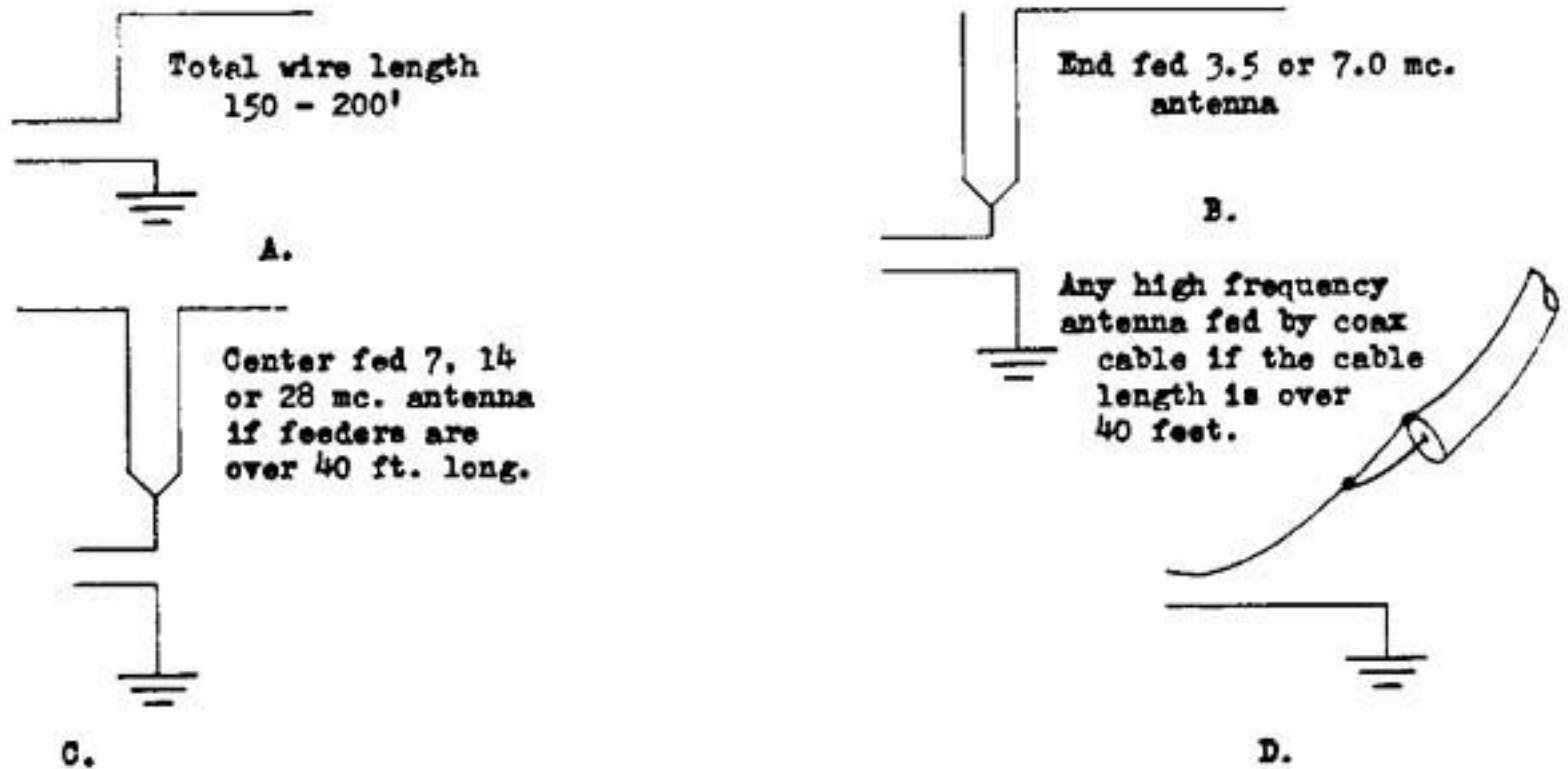
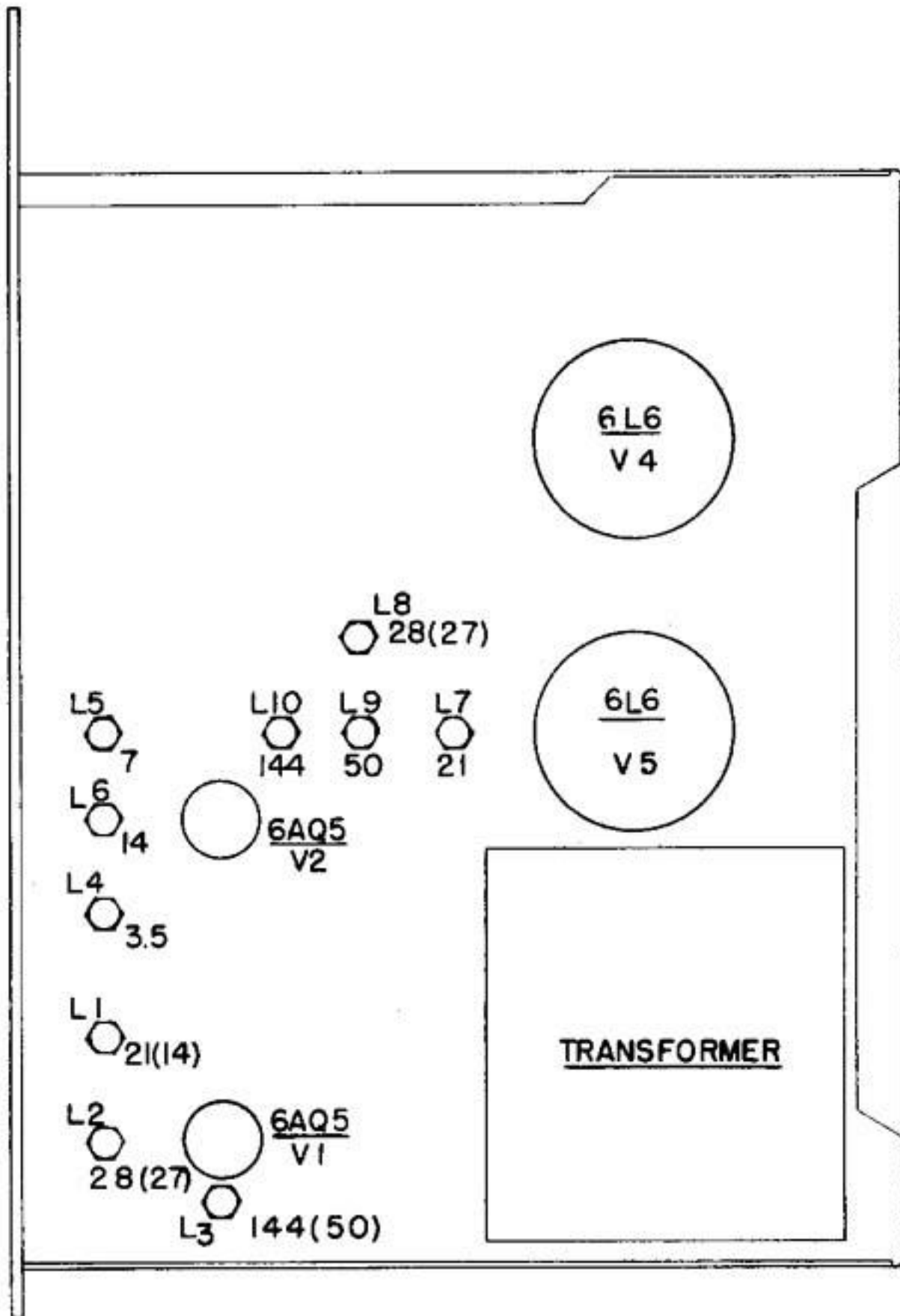

Figure 14.

All the above, except A and B, may need a series loading coil to resonate the antennas to 1.8 mc. as shown in Figure 13.

Refer to amateur publications and handbooks for other types of antenna systems for 1.8 mc. and further suggestions on tuning and loading.



RIGHT SIDE VIEW

FIGURE 15

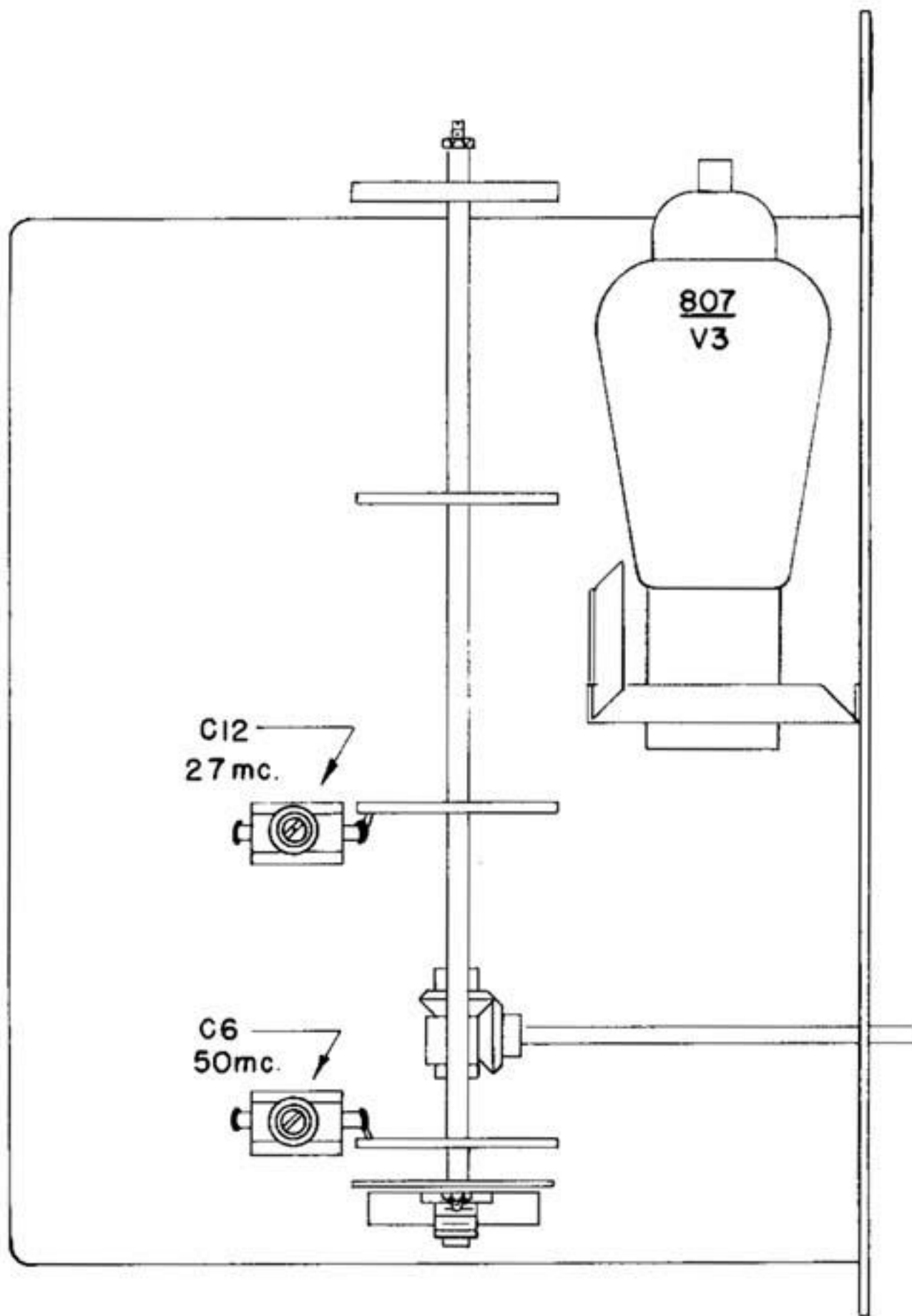

LEFT SIDE VIEW

FIGURE 16

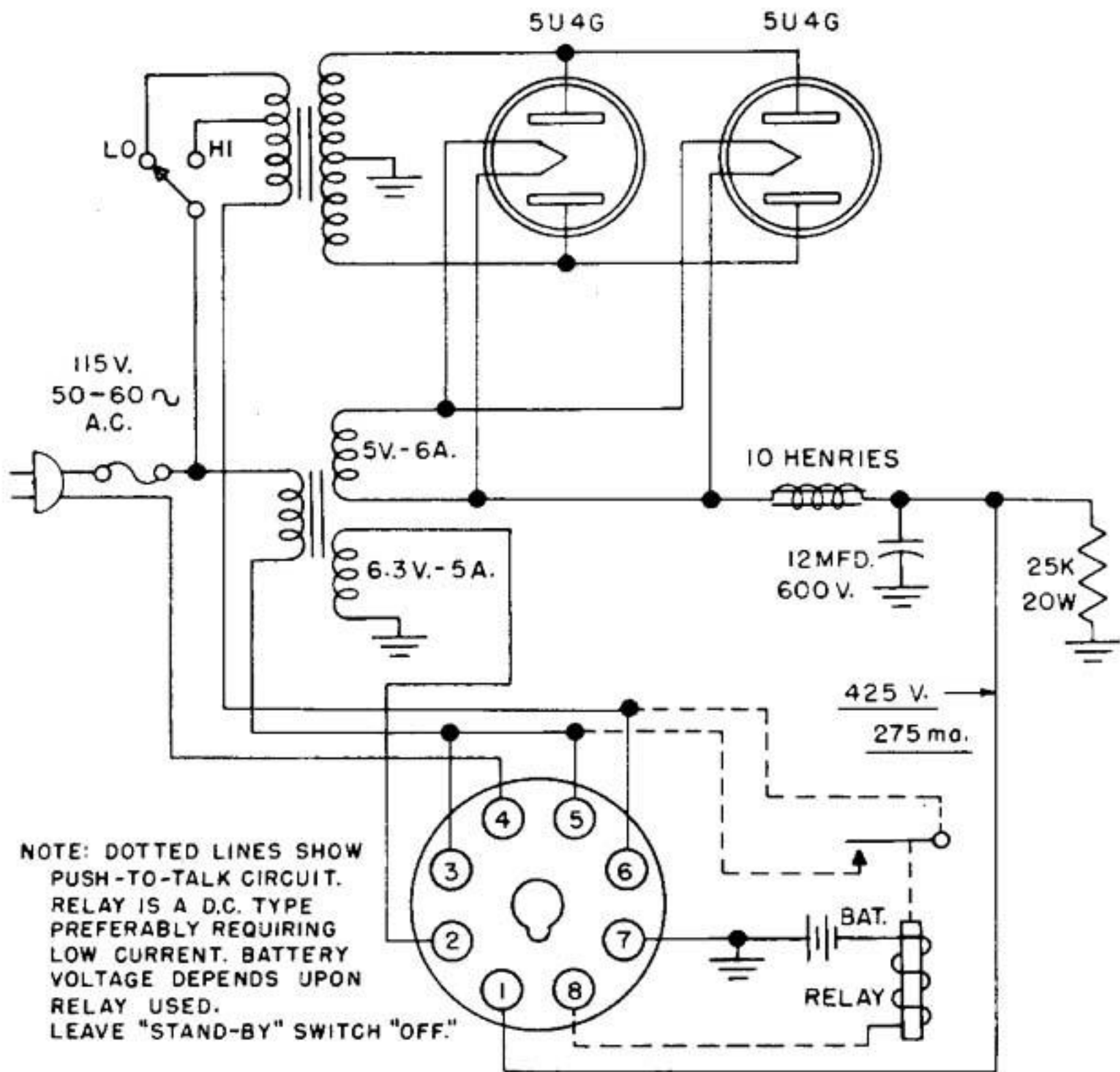

SCHEMATIC  
MODEL APS-50 A.C. POWER SUPPLY

Figure 17

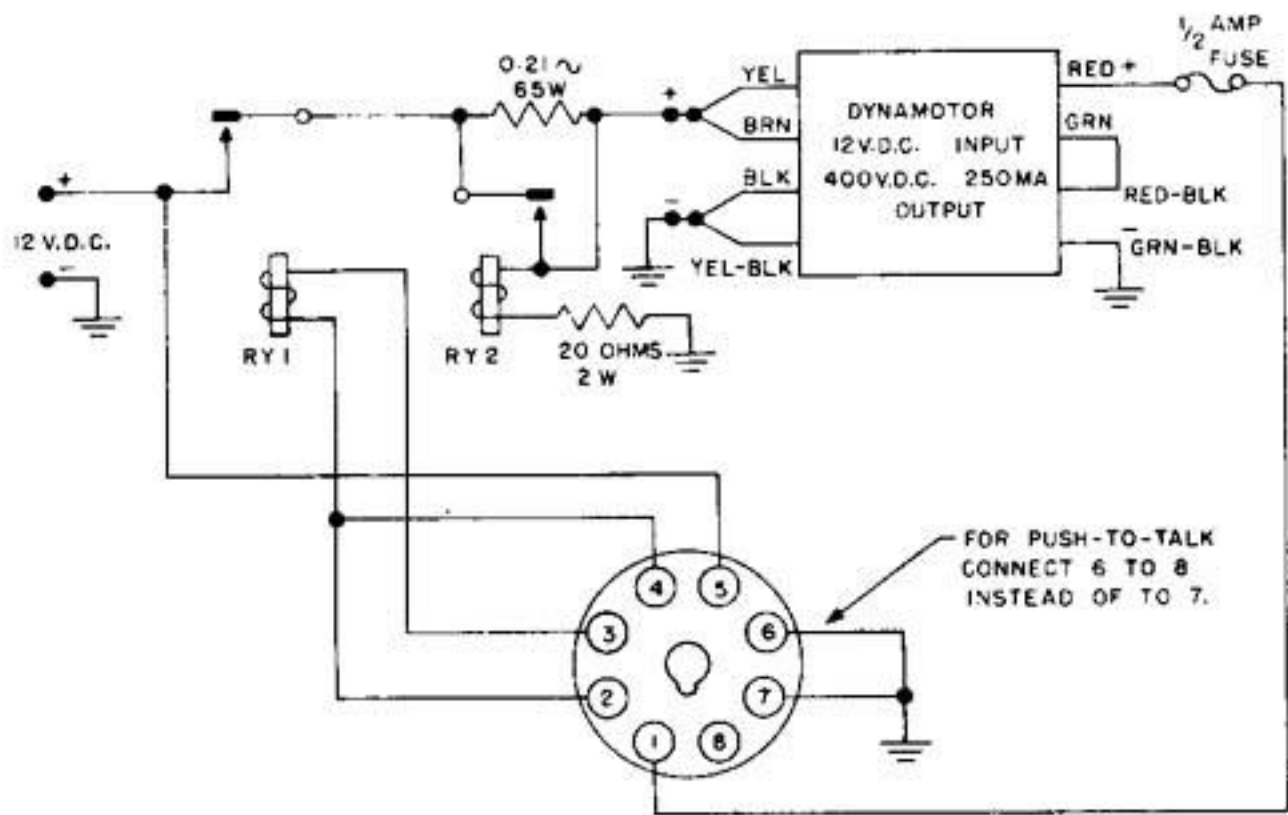

SCHEMATIC DIAGRAM  
DPS - 5012

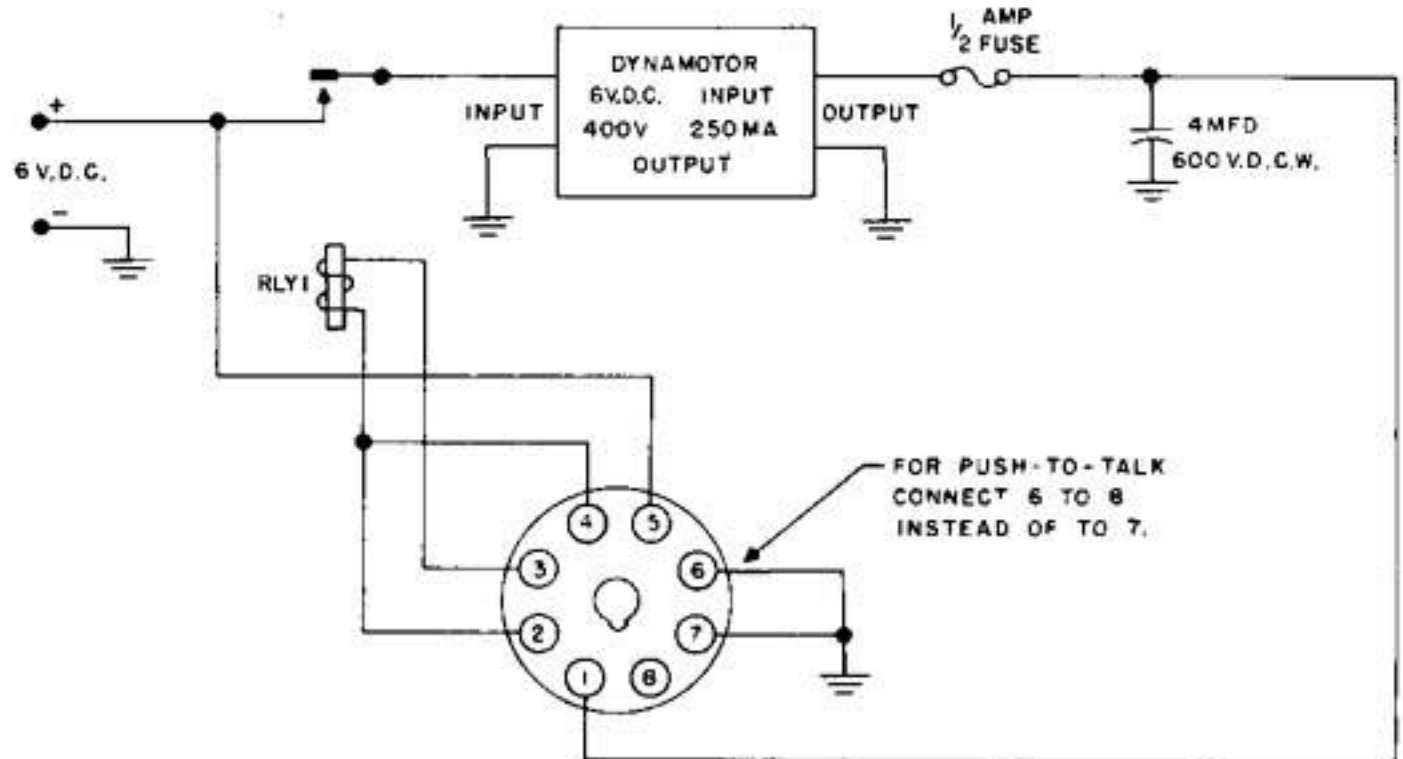

SCHEMATIC DIAGRAM  
DPS - 5006

Figure 18



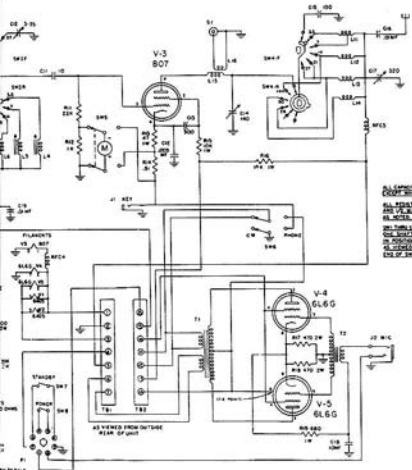

ALL CAPACITORS IN THIS  
CIRCUIT ARE OF THE  
MILITARY TYPE UNLESS  
OTHERWISE SPECIFIED  
IN THE PART LIST  
RESISTORS ARE OF THE  
MILITARY TYPE UNLESS  
OTHERWISE SPECIFIED  
IN THE PART LIST

AS VIEWED FROM OUTSIDE  
REAR OF UNIT

TUBES	
V-3	6X4
V-4	6L6G
V-5	6L6G

**SCHEMATIC DIAGRAM  
MODEL TR5-C**

NO.	DESCRIPTION	QTY.	REMARKS
1	6X4	1	RECTIFIER
2	6L6G	2	AF AMP & AUDIO OUT
3	6X4	1	DETECTOR & AF AMP
4	6L6G	1	AUDIO OUT
5	6X4	1	DETECTOR & AF AMP
6	6L6G	1	AUDIO OUT
7	6X4	1	DETECTOR & AF AMP
8	6L6G	1	AUDIO OUT
9	6X4	1	DETECTOR & AF AMP
10	6L6G	1	AUDIO OUT



STAGE	FREQ RANGE	CRYSTAL FREQ	OSC OUTPUT FREQ.	COIL	H-W PART NO.	AMPLIFIER OUTPUT FREQ.	COIL	H-W PART NO.	P.A. OUTPUT FREQ.	COIL	H-W PART NO.
12	3.5 4.0	3500 4000	3500 4000	RFLZ	12A1001-1	3500 4000	L4	12C1012-44	3500 4000	L11	12Q015-1
13	7.0 7.5	3500 3650	3500 3650	RFLZ	12A1001-1	7000 7300	L5	12C1012-501	7000 7300	L11	12Q015-1
14	14.0 14.4	3500 3600	7000 7200	L1	12C1012-501	14000 14400	L6	12C1012-502	14000 14400	L12	12Q015-2
21	21.0 21.5	3500 3583.5	7000 7166.5	L1	12C1012-501	21000 21500	L7	12C1012-505	21000 21500	L13	12Q015-3
22	27.16 27.45	6750 6857.5	13500 13715	L2	12C1012-502	27160 27450	L8	12C1012-506	27160 27450	L13	12Q015-3
10	28.0 29.7	7000 7425	14000 14850	L2	12C1012-502	28000 29700	L8	12C1012-506	28000 29700	L13	12Q015-3
50	50.0 54.0	5555 T 6000	11110.5 18000	L3	12C1012-503	50000 54000	L9	12C1013-501	50000 54000	L14	12Q015-4
14	144.0 148.0	8000 8222	24000 24666	L3	12C1012-503	72000 74000	L10	12C1014-501	144000 148000	L15	12Q015-5

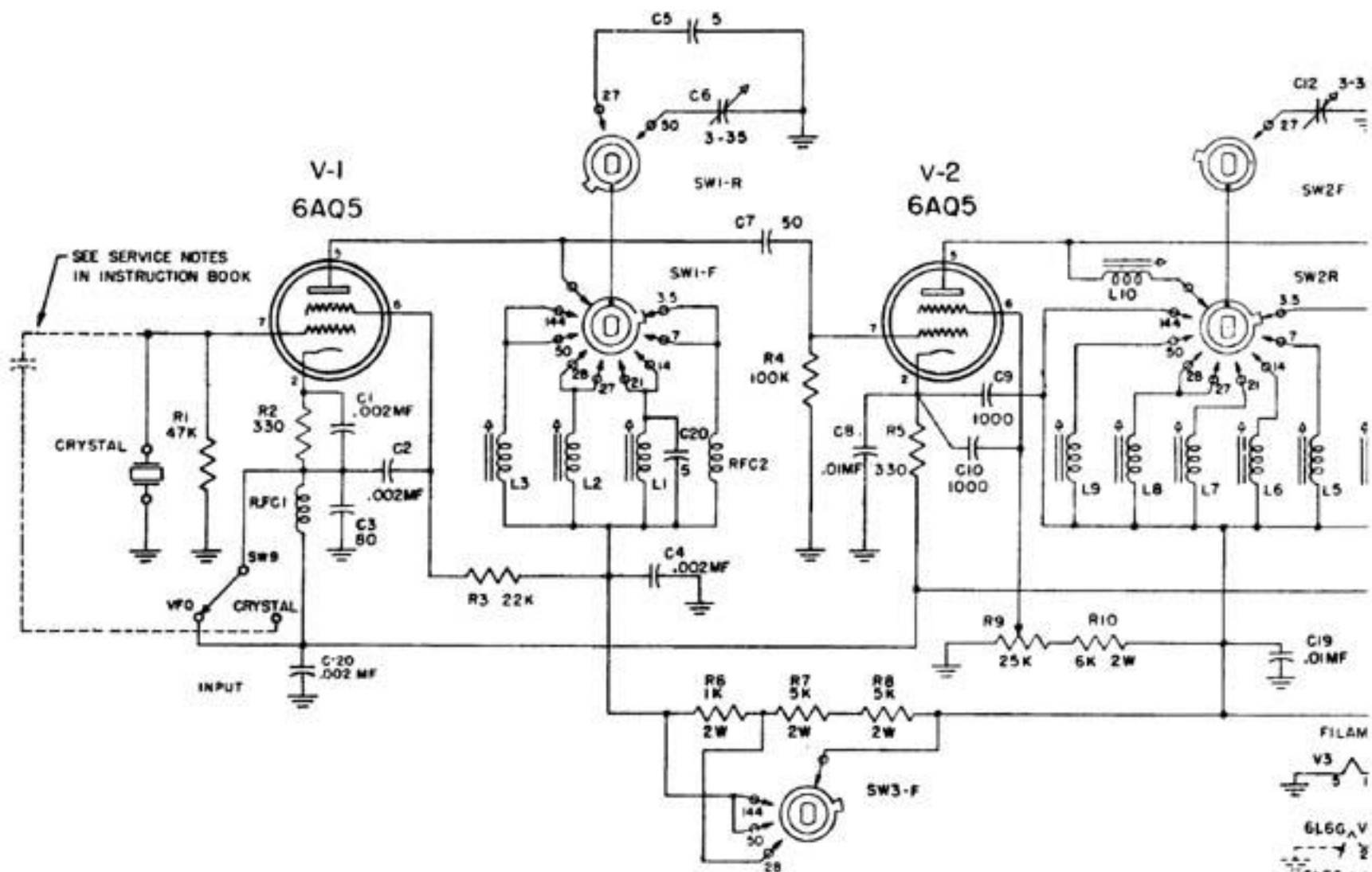

SEE SERVICE NOTES  
IN INSTRUCTION BOOK

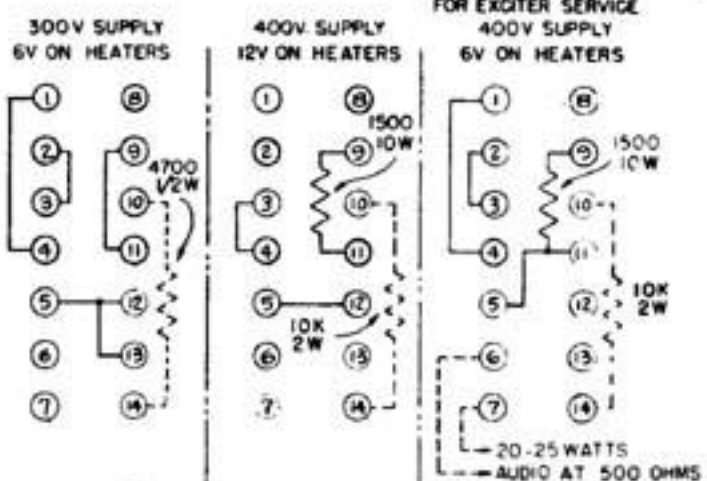

EXTERNAL CONNECTIONS, TB1 & TB2 FOR  
USE AS INDICATED ABOVE EACH.

Band	Freq. Range	Crystal Freq.	Exc. Output Freq.	Grid	6-F Part No.	Multipplier Output Freq.	Grid	6-F Part No.	P.A. Output Freq.	Grid	6-F Part No.
3-5	3.1 4.5	1500 4000	3500 4000	6PC2	12A1001-1	3500 4000	1A	12C1012-30A	3500 4000	1A1	12C1013-1
7	7.0 7.1	1500 3050	3500 3650	6PC2	12A1001-1	3500 3500	1B	12C1012-30B	3500 3500	1B1	12C1013-1
14	14.00 14.15	1500 1507.5	3500 3512.5	L1	12C1013-30	14000 14150	1A	12C1012-30	14000 14150	1B1	12C1013-2
21	21.0 21.45	1500 1515	3500 3532.5	L1	12C1013-30	21000 21450	1A	12C1012-30	21000 21450	1B1	12C1013-3
27	27.0 27.27	1500 1513.5	3500 3530.75	L2	12C1013-30	27000 27225	1A	12C1012-30	27000 27225	1B1	12C1013-3
28	28.0 28.1	1500 1505	3500 3510	L2	12C1013-30	28000 28100	1A	12C1012-30	28000 28100	1B1	12C1013-3
50	50.0 54.0	1515.3 1600	3534.65 3600	L3	12C1013-30	50000 54000	1A	12C1012-30	50000 54000	1B4	12C1013-4
144	144.0 144.0	8000 8222	8000 8444	L1	12C1013-30	70000 74000	1A	12C1012-30	140000 148000	1B1	12C1013-5

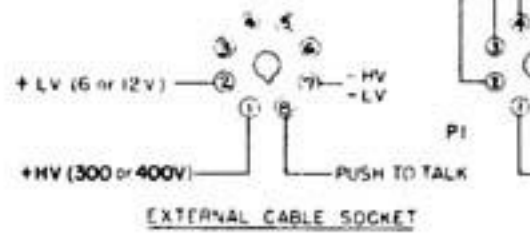

EXTERNAL CABLE SOCKET

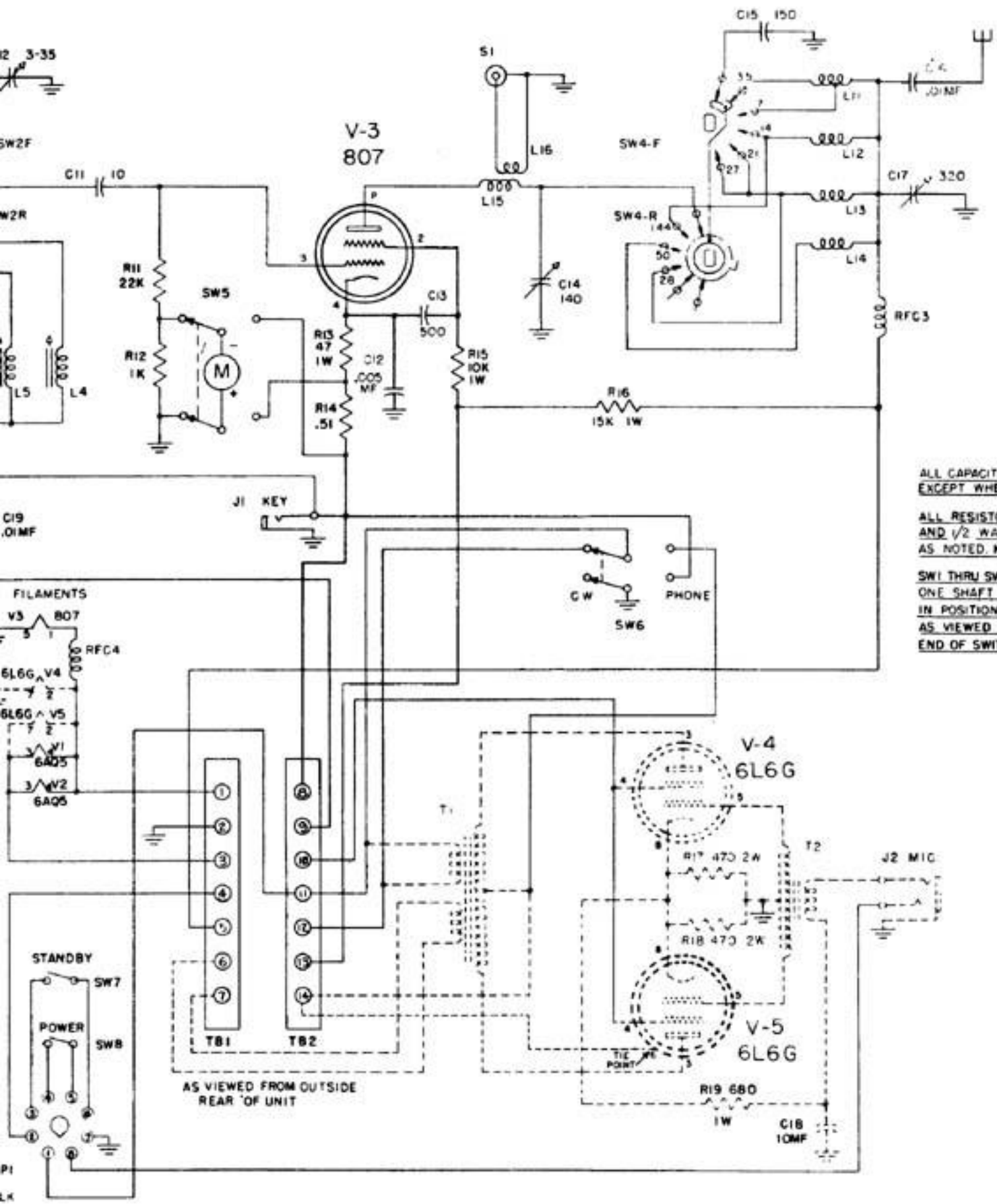

ALL CAPACITIES IN MMF EXCEPT WHERE NOTED

ALL RESISTORS IN OHMS AND 1/2 WATT EXCEPT AS NOTED. K=1000

SW1 THRU SW4 GANGED ON ONE SHAFT AND SHOWN IN POSITION ONE (3.5MC) AS VIEWED FROM DETENT END OF SWITCH SHAFT.

AS VIEWED FROM OUTSIDE REAR OF UNIT

TOLERANCES ON FINISHED DIMENSIONS EXCEPT AS OTHERWISE INDICATED			SCHEMATIC DIAGRAM MODEL TB5-50 B	
SIZE	FRACTIONAL DIMENSION	TOLERANCE	DATE	BY
UP TO .125		+ .005		
.125 TO .250		+ .005		
.250 TO .500		+ .005		
ABOVE .500		+ .010		
HARVEY WELLS ELECTRONICS INC. NEW YORK, N.Y.			91A1064	

Band	Freq. Range	Crystal Freq.	Osc. Output Freq.	Coil	H-W Part No.	Multiplier Output Freq.	Coil	H-W Part No.	P.A. Output Freq.	Coil	H-W Part No.
3.5'	3.5 4.0	3500 4000	3500 4000	RPC2	12A1001-1	3500 4000	L4	12C1012-504	3500 4000	L11	12C1015-1
7	7.0 7.3	3500 3650	3500 3650	RPC2	12A1001-1	7000 7300	L5	12C1012-501	7000 7300	L11	12C1015-1
14	14.00 14.35	3500 3587.5	7000 7175	L1	12C1012-501	14000 14350	L6	12C1012-502	14000 14350	L12	12C1015-2
21	21.0 21.45	3500 3575	7000 7150	L1	12C1012-501	21000 21450	L7	12C1012-505	21000 21450	L13	12C1015-3
27	26.96 27.23	6740 6807.5	13480 13615	L2	12C1012-502	26960 27230	L8	12C1012-506	26960 27230	L13	12C1015-3
28	28.0 29.7	7000 7425	14000 14850	L2	12C1012-502	28000 29700	L8	12C1012-506	28000 29700	L13	12C1015-3
50	50.0 54.0	5555.5 6000	16666.5 18000	L3	12C1012-503	50000 54000	L9	12C1013-501	50000 54000	L14	12C1015-4
144	144.0 148.0	8000 8222	24000 24666	L3	12C1012-503	72000 74000	L10	12C1014-501	144000 148000	L15	12C1015-5

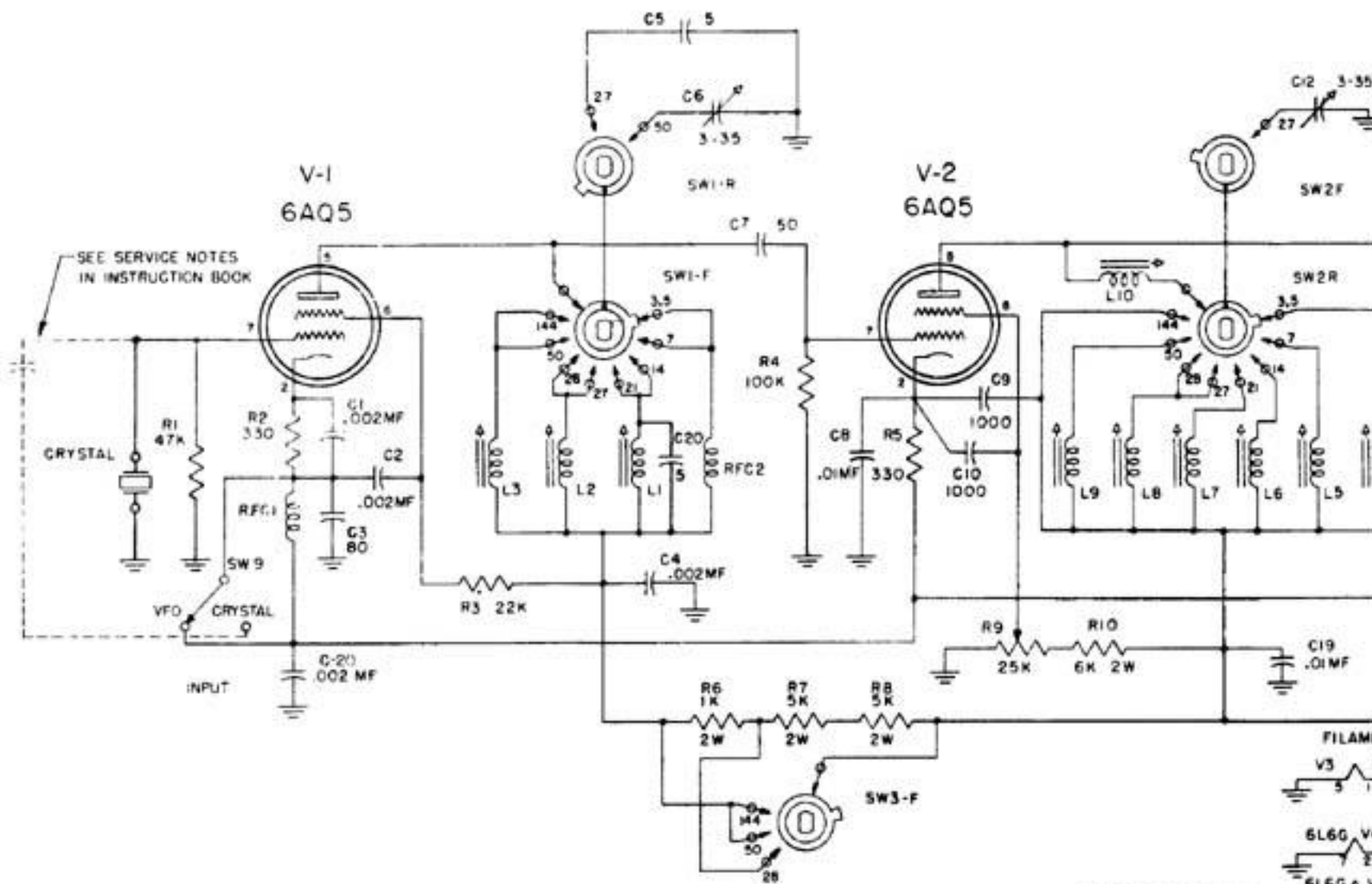

SEE SERVICE NOTES  
IN INSTRUCTION BOOK

300V SUPPLY  
6V ON HEATERS

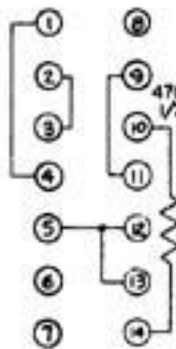

400V SUPPLY  
12V ON HEATERS

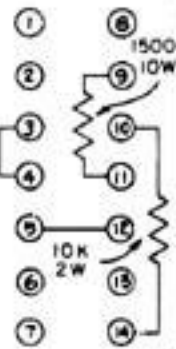

FOR EXCITER SERVICE  
400V SUPPLY  
6V ON HEATERS

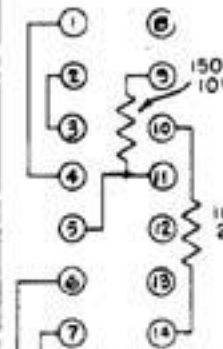

EXTERNAL CONNECTIONS, TB1 & TB2 FOR  
USE AS INDICATED ABOVE EACH.

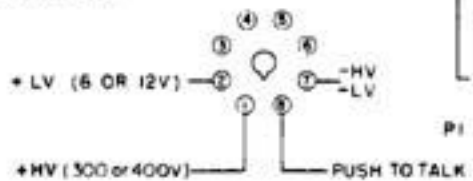

EXTERNAL CABLE SOCKET

Band	Freq. Range	Crystal Freq.	Sec. Octave Freq.	Coil	n-W Part No.	Multiplier	Coil	n-W Part No.	F.A. Octave Freq.	Coil	n-W Part No.
3-7	3.1 4.0	3500 4000	3500 4000	WFC1	12AL01A-1	1500 4000	1A	12X012-30A	3500 4000	121	12X012-1
7	7.0 7.5	2800 3600	3500 3500	WFC2	12AL01A-1	7000 7000	1B	12X012-30B	7000 7000	121	12X012-1
14	14.00 14.35	1900 2587.5	7000 7175	1A	12X012A-30A	14000 14175	1A	12X012-30A	14000 14175	122	12X012A-1
21	21.0 21.45	1300 1575	7000 7150	1A	12X012A-30A	26000 26150	17	12X012-30A	26000 26150	123	12X012A-3
27	26.95 27.25	4750 6075.5	13450 13625	1A	12X012A-30A	26900 27200	18	12X012-30A	26900 27200	123	12X012A-3
38	38.0 38.7	7000 9450	14000 14700	1A	12X012A-30A	28000 29700	18	12X012A-30A	28000 29700	123	12X012A-3
50	50.0 54.0	5155.5 6000	14665.5 18000	1A	12X012A-30A	50000 54000	18	12X012A-30A	50000 54000	124	12X012A-4
144	144.0 147.0	8000 8222	26000 26666	1A	12X012A-30A	78000 79000	123	12X012A-30A	78000 79000	125	12X012A-1

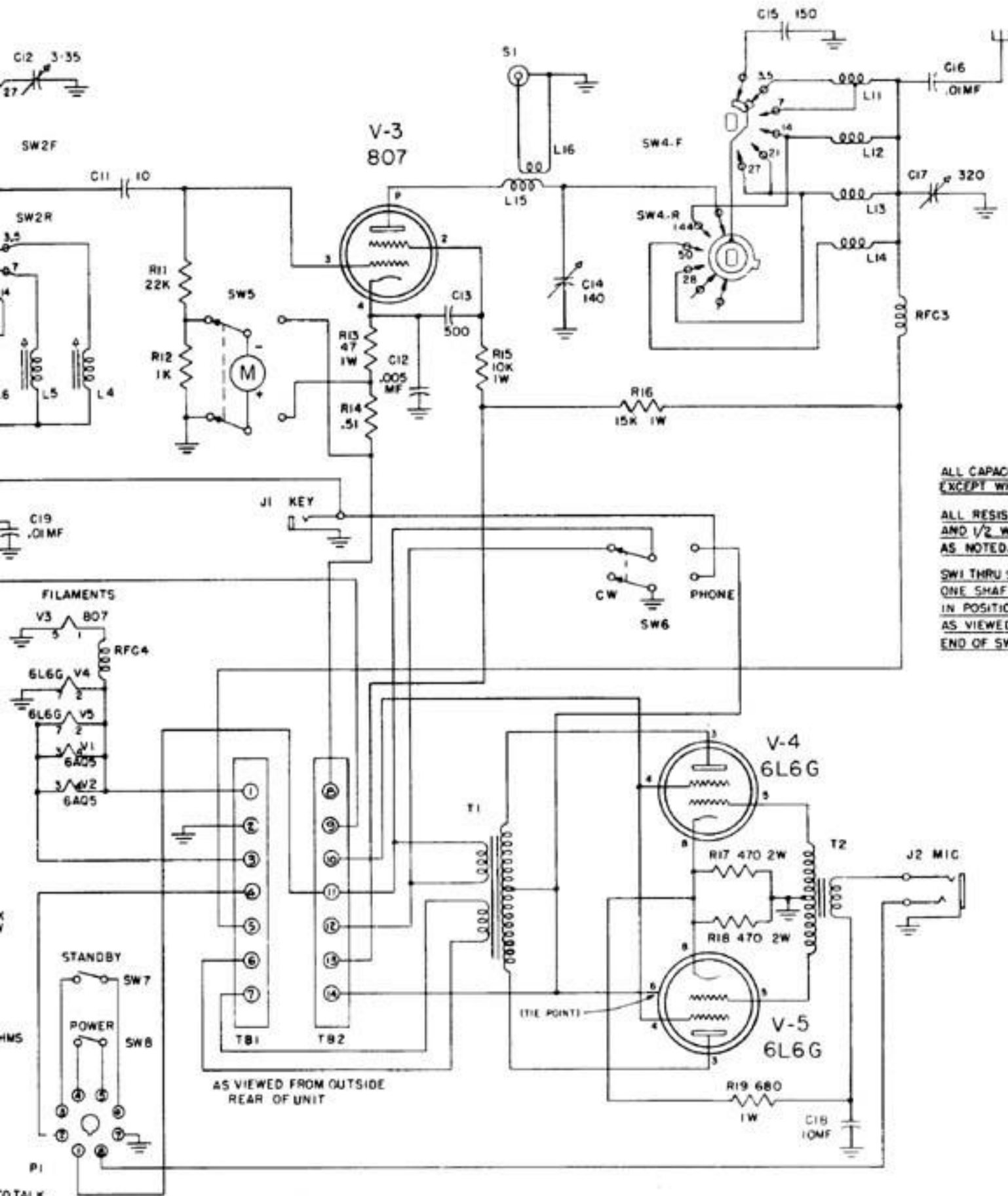

ALL CAPACITIES IN MMF.  
EXCEPT WHERE NOTED.

ALL RESISTORS IN OHMS  
AND 1/2 WATT EXCEPT  
AS NOTED. K=1000

SW1 THRU SW4 GANGED ON  
ONE SHAFT AND SHOWN  
IN POSITION ONE (3.5 MC)  
AS VIEWED FROM DETENT  
END OF SWITCH SHAFT.

AS VIEWED FROM OUTSIDE  
REAR OF UNIT

SCHEMATIC DIAGRAM  
MODEL TBS-50 C

<small>DESIGNED BY: H. W. WELLS</small> <small>CHECKED BY: H. W. WELLS</small> <small>DATE: 11-1-54</small>	
<small>HARVEY WELLS ELECTRONICS, INC. SANTA ANA, CALIF.</small>	91A1054



Band	Freq. Range	Crystal Freq.	Osc. Output Freq.	Coil	H-W Part No.	Multiplier Output Freq.	Coil	H-W Part No.	P.A. Output Freq.	Coil	H-W Part No.
3.5	3.5 4.0	3500 4000	3500 4000	RFC2	12A1001-1	3500 4000	L4	12C1012-504	3500 4000	L11	12C1015-1
7	7.0 7.3	3500 3650	3500 3650	RFC2	12A1001-1	7000 7300	L5	12C1012-501	7000 7300	L11	12C1015-1
14	14.00 14.35	3500 3587.5	7000 7175	L1	12C1012-501	14000 14350	L6	12C1012-502	14000 14350	L12	12C1015-2
21	21.0 21.45	3500 3575	7000 7150	L1	12C1012-501	21000 21450	L7	12C1012-505	21000 21450	L13	12C1015-3
27	26.96 27.23	6740 6807.5	13480 13615	L2	12C1012-502	26960 27230	L8	12C1012-506	26960 27230	L13	12C1015-3
28	28.0 29.7	7000 7425	14000 14850	L2	12C1012-502	28000 29700	L8	12C1012-506	28000 29700	L13	12C1015-3
50	50.0 54.0	5555.5 6000	16666.5 18000	L3	12C1012-503	50000 54000	L9	12C1013-501	50000 54000	L14	12C1015-4
144	144.0 148.0	8000 8222	24000 24666	L3	12C1012-503	72000 74000	L10	12C1014-501	144000 148000	L15	12C1015-5



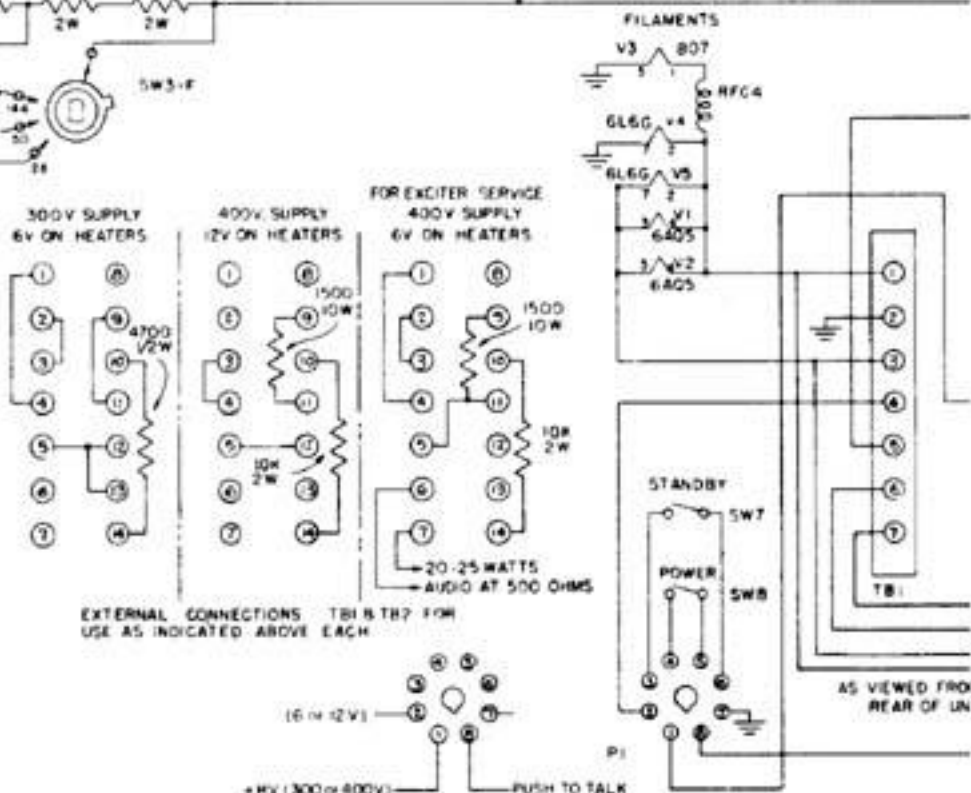
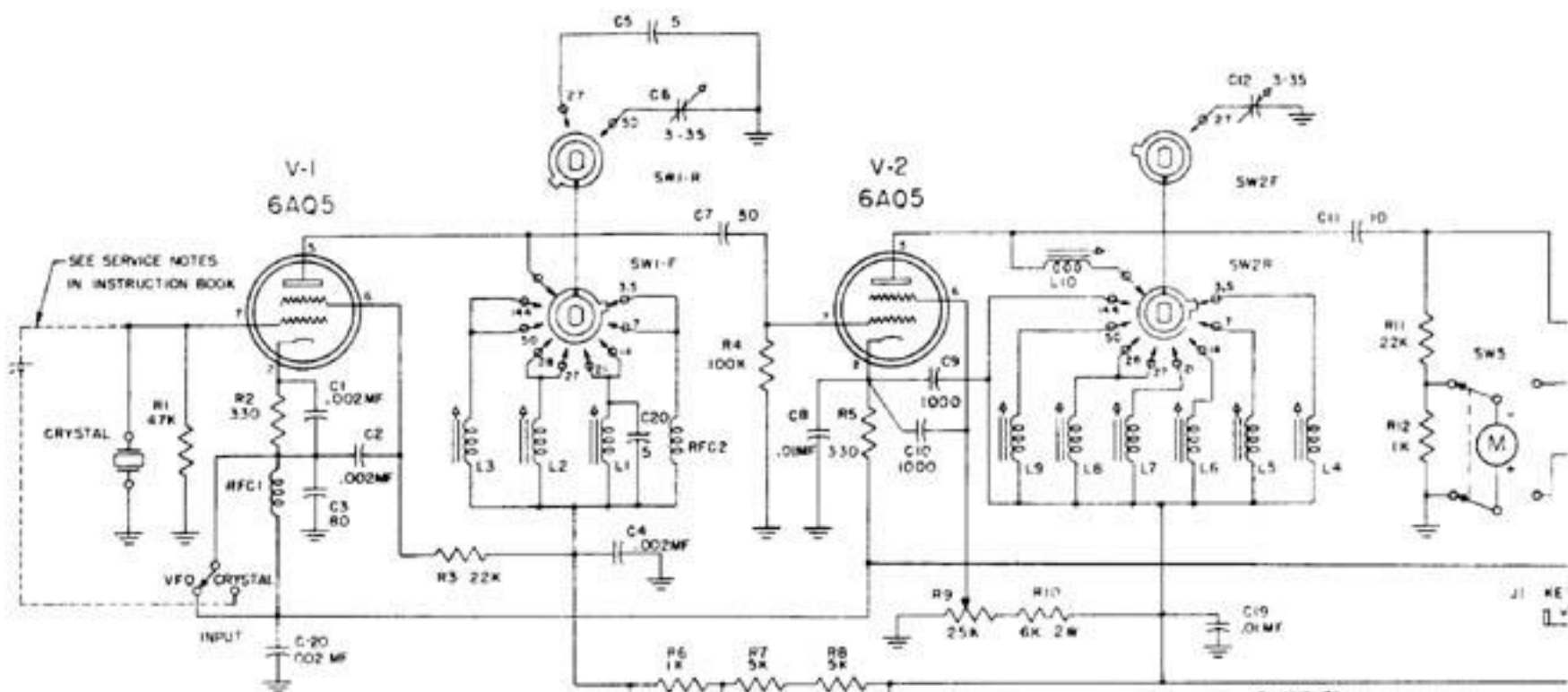

Band	Freq. Range	Crystal Freq.	Dev. Output Freq.	Grid	Watt. Req. B+	Multiplier Output Freq.	Grid	Watt. Req. B+	P.A. Output Freq.	Grid	Watt. Req. B+
3.5	7.5-11.5	7500 4500	7500 4500	6PC2	120000-5	7500 4500	1A	120000-50A	7500 4500	121	120000-5
7	7.5-11.5	7500 4500	7500 4500	6PC2	120000-5	7500 4500	L1	120000-50B	7500 4500	122	120000-5
14	14.0-21.0	7500 4500	7500 4500	6A	120000-50C	15000 9000	1A	120000-50D	15000 9000	123	120000-5
21	21.0-31.5	7500 4500	7500 4500	6A	120000-50E	22500 13500	L7	120000-50F	22500 13500	124	120000-5
28	28.0-42.0	7500 4500	7500 4500	6A	120000-50G	30000 18000	6P	120000-50H	30000 18000	125	120000-5
35	35.0-52.5	7500 4500	7500 4500	6A	120000-50I	37500 22500	6P	120000-50J	37500 22500	126	120000-5
42	42.0-63.0	7500 4500	7500 4500	6A	120000-50K	45000 27000	6P	120000-50L	45000 27000	127	120000-5

EXTERNAL CONNECTIONS TBI & TH? FOR USE AS INDICATED ABOVE EACH

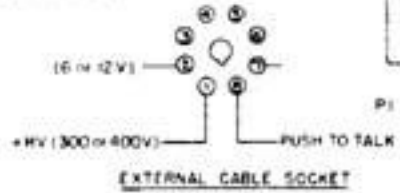

AS VIEWED FROM REAR OF IN

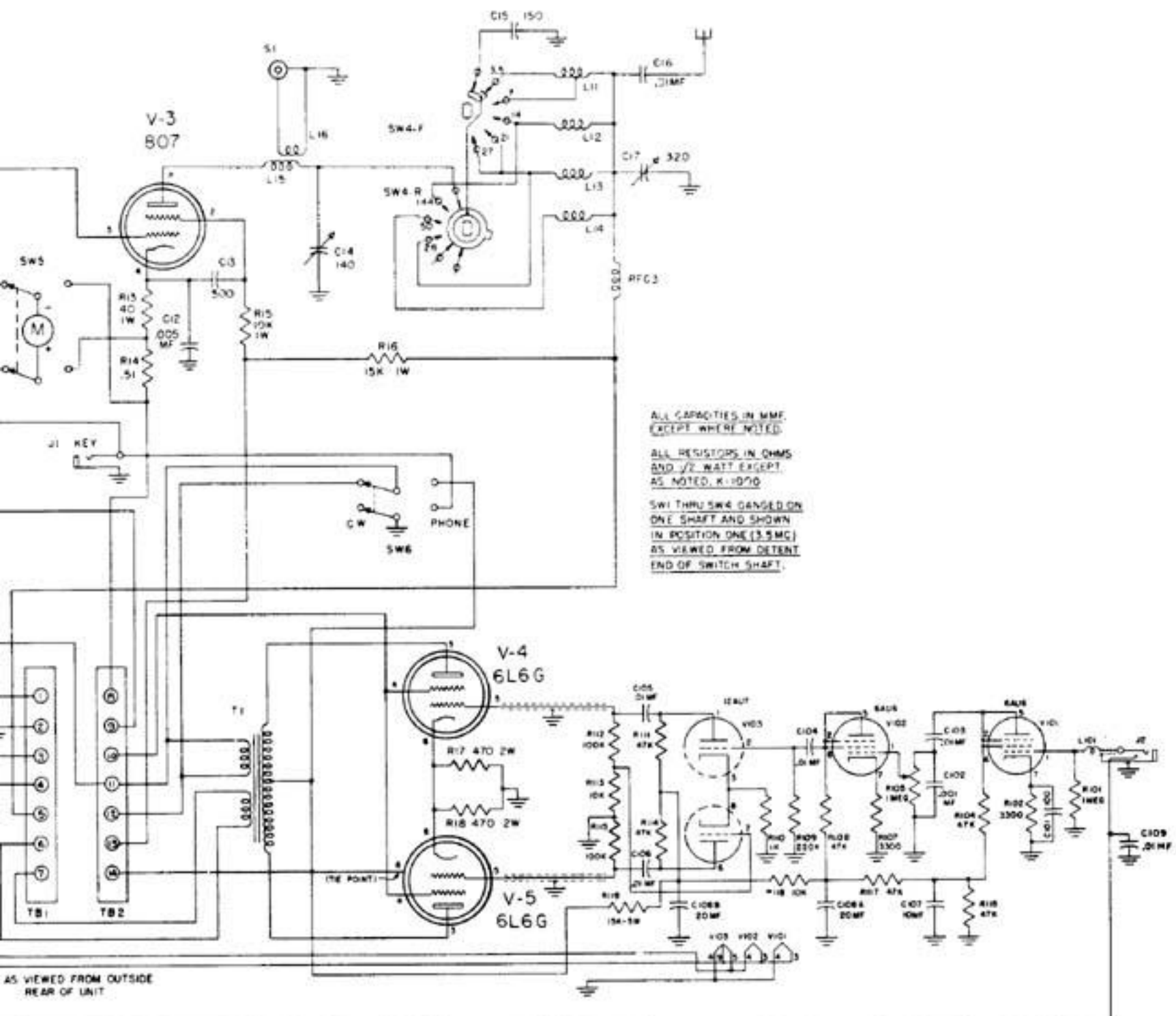

ALL CAPACITIES IN MMF.  
EXCEPT WHERE NOTED.

ALL RESISTORS IN OHMS  
AND 1/2 WATT EXCEPT  
AS NOTED. K=1000

SW1 THRU SW4 GANGED ON  
ONE SHAFT AND SHOWN  
IN POSITION ONE (3.5 MC)  
AS VIEWED FROM DETENT  
END OF SWITCH SHAFT.

SCHEMATIC DIAGRAM  
MODEL TBS-50 D

HARVEY WELLS ELECTRONIC CO. 111-11300 11th St. N.E.		91A1055
---	--	---------

Band	Freq. Range	Crystal Freq.	Osc. Output Freq.	Coil	H-W Part No.	Multiplier Output Freq.	Coil	H-W Part No.	P.A. Output Freq.	Coil	H-W Part No.
3.5	3.5 4.0	3500 4000	3500 4000	RPC2	12A1001-1	3500 4000	L4	12C1012-504	3500 4000	L11	12C1015-1
7	7.0 7.3	3500 3650	3500 3650	RPC2	12A1001-1	7000 7300	L5	12C1012-501	7000 7300	L11	12C1015-1
14	14.00 14.35	3500 3587.5	7000 7175	L1	12C1012-501	14000 14350	L6	12C1012-502	14000 14350	L12	12C1015-2
21	21.0 21.45	3500 3575	7000 7150	L1	12C1012-501	21000 21450	L7	12C1012-505	21000 21450	L13	12C1015-3
27	26.96 27.23	6740 6807.5	13480 13615	L2	12C1012-502	26960 27230	L8	12C1012-506	26960 27230	L13	12C1015-3
28	28.0 29.7	7000 7425	14000 14850	L2	12C1012-502	28000 29700	L8	12C1012-506	28000 29700	L13	12C1015-3
50	50.0 54.0	5555.5 6000	16666.5 18000	L3	12C1012-503	50000 54000	L9	12C1013-501	50000 54000	L14	12C1015-4
144	144.0 148.0	8000 8222	24000 24666	L3	12C1012-503	72000 74000	L10	12C1014-501	144000 148000	L15	12C1015-5