

PRICE 21/-



**Assembling
and
Using Your...**



TRANSMITTER

MODEL DX - 100 U

DAYSTROM LIMITED

A Subsidiary of the Daystrom Group,
Manufacturers of the world's finest
Electronic Equipment in Kit Form.

GLOUCESTER, ENGLAND

Assembly and Operation of the Heathkit Transmitter

MODEL DX - 100 U

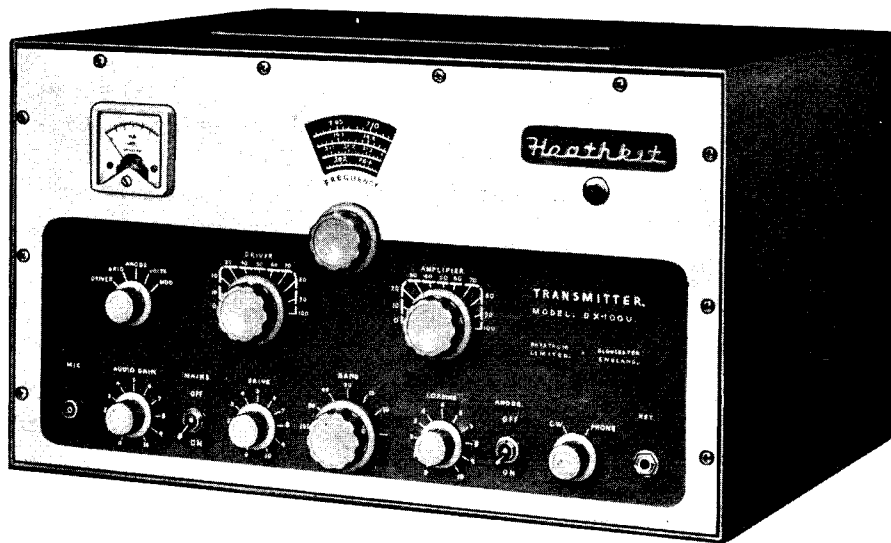

SPECIFICATIONS

RF Power Output:.....	100-125 watts phone, 120-140 watts CW
Output Impedance:	50-600Ω (non-reactive)
Output Coupling:.....	Pi network (coaxial)
Operation:	Crystal-VFO, CW-Phone, Local-Remote
Bands Covered:.....	160, 80, 40, 20, 15 and 10 metres
Audio Output:.....	100 watts at 300-3000 cycles
Valve Complement:	
Power Section.....	6AL5 bias rectifier 5U4G low voltage rectifier 2 - 5R4GY high voltage rectifier OA2 regulator
Audio Section.....	12AX7 speech amplifier 6CH6 audio driver 2 - KT88 push-pull modulator
RF Section.....	6AU6 VFO 6CH6 crystal oscillator-buffer 5763 driver 2 - 6L46 (in parallel) power amplifier 6AQ5 clamp
Power requirements:.....	95 to 150 or 195 to 250 volts AC, 45 to 65 cycles
Standby.....	150 watts
CW.....	400 watts (intermittent)
Phone.....	450-600 watts
Cabinet Size:.....	19½" wide x 11½" high x 16" deep
Net Weight:	100 lbs.
Shipping Weight:.....	114 lbs.

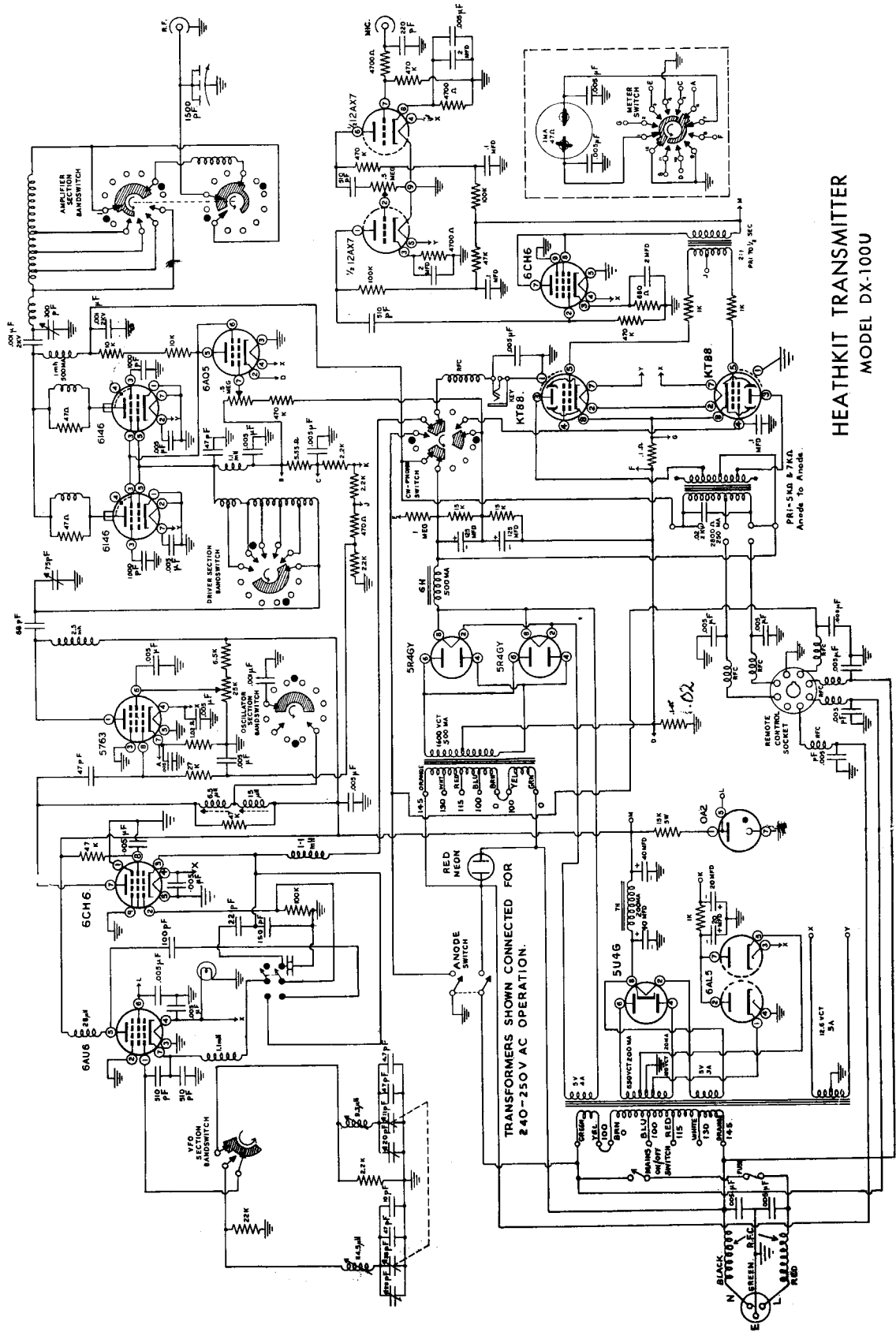

HEATHKIT TRANSMITTER
MODEL DX-1000

TRANSFORMERS SHOWN CONNECTED FOR 240-250V AC OPERATION.

INTRODUCTION

The Heathkit model DX-100U Transmitter represents the complete transmitting complement for the amateur transmitting station. The only external requirements are antenna, earth and key or microphone. Panel controls allow Phone or CW operation on all amateur bands up to 30 mc. The DX-100U includes three power supplies, low voltage, main HT voltage and fixed bias, four radio frequency stages and four audio stages.

The pi network output coupling tends to suppress harmonics and will match a wide range of antenna impedances. The original Heath VFO has been redesigned for use in the DX-100U. The use of air trimmer capacitors, relocation of temperature compensating elements and tighter shielding, have improved the stability and operating characteristics. Panel controls include key and microphone connections, audio gain, drive control, bandswitch, loading control, phone-CW switch, VFO tuning, driver tuning, final tuning, mains and main HT switches. Crystal-VFO switch accessible through door in top of cabinet. A socket on the rear of the transmitter is so connected to allow remote control of the transmitter or to operate an antenna relay. It also makes 80 watts of audio at 500Ω available for driving a larger modulator or for public address work.

The block diagram and circuit description will give the builder a better understanding of the transmitter. This knowledge is an invaluable aid to construction and as such, is well worth reading thoroughly.

IN A TRANSMITTER OF THIS SIZE, LETHAL VOLTAGES ARE PRESENT, CONSEQUENTLY GREAT CARE MUST BE EXERCISED WHEN ANY TESTS OR ADJUSTMENTS ARE MADE.

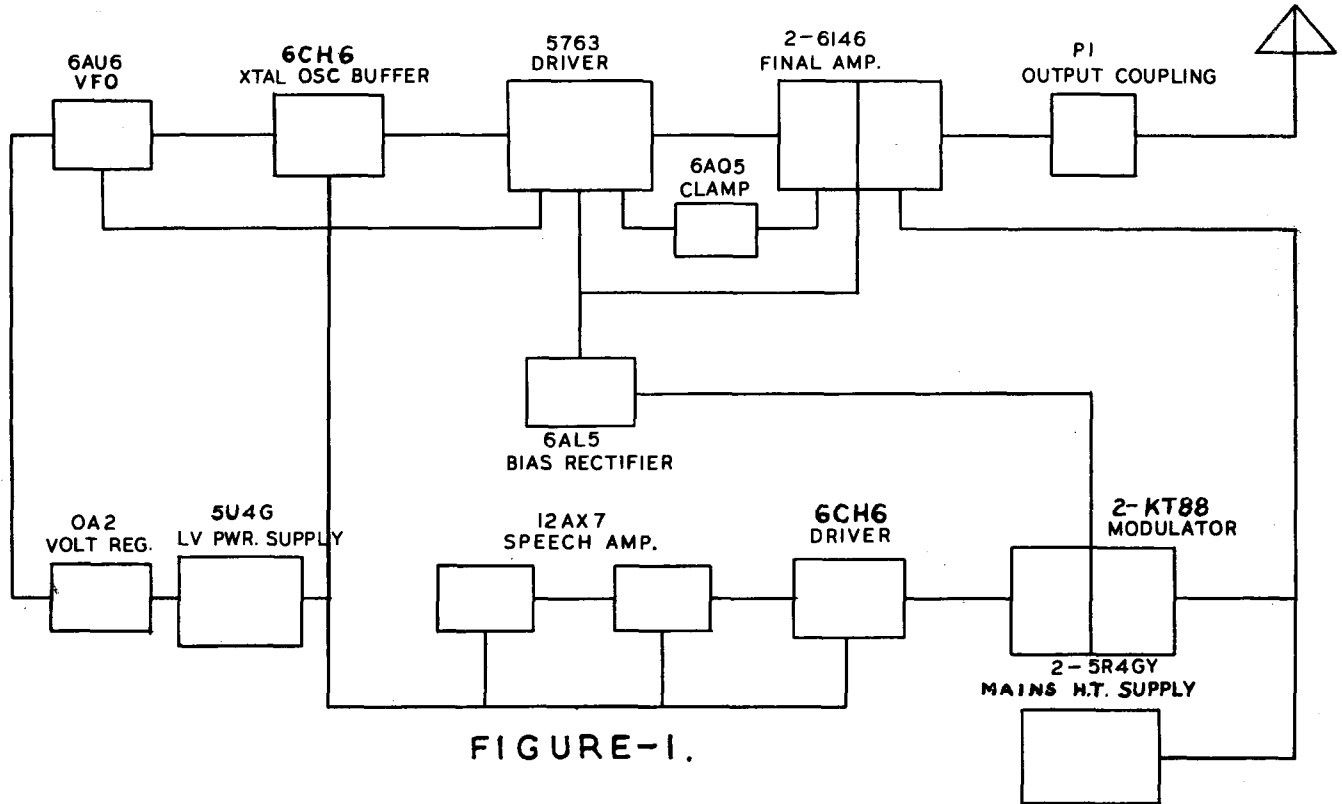

FIGURE-1.

CIRCUIT DESCRIPTION
VFO

The VFO circuit consists of a 6AU6 valve operating as a Clapp oscillator in the frequency ranges of 1750 to 2000 kc and 7000 to 7425 kc. To prevent undue heating effects, the valve is mounted on top and outside of the VFO enclosure. All the frequency determining components are mounted rigidly inside the shielded enclosure. A double bearing ceramic insulated tuning capacitor of the differential type is used as a frequency control. The differential capacitor having two stator assemblies of different capacity, permits a large bandwidth at high frequencies as well as the lower frequencies. Ceramic insulated air trimmers prevent initial drift during calibration.

The coils are wound with Litz or double cellulose wire on heavy ceramic formers, doped with Q-max and baked. This combination achieves high Q, low drift and decreases the effect of humidity. Temperature compensating capacitors mounted in close proximity to the coils decrease slightly in capacity as the coil inductance increases with heating. The capacitors tend to raise the frequency and the inductances tend to lower the frequency. By properly proportioning these components, the effect of one cancels the other and the frequency remains constant. The VFO switch is mounted vertically inside the compartment and operated by an interrupted switching mechanism on the band switch. This co-relates the VFO output frequency with the band in use.

The Clapp or series-tuned Colpitts oscillator circuit presents a very low impedance at resonance for the valve grid to look into. This minimises the effect of shift in valve capacitance upon the output frequency. A large capacitive voltage divider necessary for operation of the Colpitts circuit also lessens the effect of valve capacitance upon frequency. The 6AU6 valve is also operating as an electron-coupled oscillator, wherein the valve screen grid operates as the oscillator anode. The screen grid voltage is stabilised at 150 volts by an OA2 regulator in the power supply. With the screen grid operating as the oscillator anode, the actual valve anode is coupled to the oscillator only by the electron stream in the valve and further shielded from the oscillator by the earthed suppressor grid. This effectively isolates the oscillator circuit from the following stages and lessens the effect of loading on the VFO frequency. The output of the VFO is broadbanded and fed to one position of the XTAL-VFO switch. This switch also opens the cathode circuit of the 6AU6 when in crystal position, thus disabling the VFO when using crystal control.

CRYSTAL OSCILLATOR - VFO BUFFER AMPLIFIER

A 6CH6 valve is used as a Colpitts oscillator. In this circuit the screen grid is earthed to RF. A choke and capacitor network in the cathode provide feedback to maintain oscillation. In general, any crystals within the amateur bands may be used, but those in the 40 metre band will give the best output on 20-15 and 10 metres. 80 or 160 metre crystals will be found suitable when operating on 160-80-40 and possibly 20 metres. In the VFO position, the 6CH6 acts as a buffer amplifier, the cathode being earthed for RF by a .005 μ F disc ceramic capacitor. The anode circuit is broad banded by slug tuned coils when switched to 40-20-15 and 10 metres. The 40 metre coil acts as an aperiodic anode impedance on 160 and 80 metres. The output of the 6CH6 is capacity coupled to the 5763 driver stage.

DRIVER STAGE

A 5763 valve operating with a combination of fixed and automatic bias, is used to drive the final amplifier. As the stage has anode voltage supplied and the cathode circuit closed, sufficient bias is necessary to keep it from drawing current during key up or standby conditions. The additional automatic bias establishes the operating bias during the "keydown" condition. A meter shunt resistor is permanently connected in the cathode circuit and the meter switched across it when reading driver current. The resistance of the shunt is such as to cause the meter to read 50 milliamperes full scale. Potentiometer control of the driver screen voltage allows control of the grid drive to the final amplifier. The anode circuit of the 5763 is shunt fed through an RF choke. Pi network interstage coupling is used between the driver and a final amplifier with the input capacitor of the pi section variable and the output capacitor fixed. The pi section inductance is tapped and the proper tap for each band selected by a section of the band switch. The use of pi network interstage coupling helps reduce the harmonic output of the transmitter. The fixed output of the pi interstage coupling appears from grid to earth of the final amplifier and shorts out the higher frequency harmonics.

FINAL AMPLIFIER

Two 6146 valves operating at approximately 700 volts are used as the power amplifier. Here also, a combination of fixed and automatic bias is used to establish the operating and standby condition. In addition to the fixed bias, the screens of the valves are clamped by a 6AQ5. The action of the clamp valve is as follows:-

The screen voltage to the 6146's is obtained through a dropping resistor from the main HT supply and the 6AQ5 valve anode is connected at the 6146 screen. The 6AQ5 cathode is grounded and its grid is common to the grid circuit of the 6146 stage. As long as grid excitation is obtained from the preceding stage, the bias developed keeps the clamp valve cut off and it does not draw current. If excitation is lost, the 6AQ5 grid goes to zero and the valve draws heavy current, dropping the voltage to the 6146 screen to a very low value, thus further protecting the 6146 stage. The fixed bias applied to the grids of the 6146 stage would normally keep the 6AQ5 cut off also, regardless of loss of excitation. Consequently, a sufficient positive voltage is applied to the 6AQ5 grid to just balance the fixed bias but not the operating bias. This allows the clamp valve to be cut off by the operating bias only.

The tank circuit of the 6146 stage is pi-coupled to the antenna, using a 300 pF variable capacitor on the input side, a tapped inductance operating from the band switch, and a 500 pF per section variable capacitor on the output. The 500 pF sections are connected in parallel, permitting smooth vernier control loading.

When modulating tetrode valves, it is necessary to modulate the screen as well as the anode. This is accomplished by supplying the screen voltage through a dropping resistor from the main HT voltage. The 6146 valves are sub-mounted on a separate plate. This serves two purposes. The plate acts as a shield to isolate the 6146 grids from the output circuit and the sub-mounting forms a chimney effect causing air to flow up past the valves for cooling.

AUDIO SECTION

Two triode stages of resistance coupled speech amplification are combined in a 12AX7 valve giving sufficient gain for a low level crystal or dynamic microphone. In amateur communications, it is desirable to sacrifice fidelity in favour of narrow bandwidth and confine the power transmitted to voice frequencies, a range of about 250 to 3000 cycles. To limit the low frequency response of the speech amplifier, the coupling condensers are small, 500 pF. This presents a high reactance to the lower frequencies. The higher frequencies over 3000 cycles per second, are attenuated in the modulator stage.

The 6CH6 driver valve is triode connected to present a low impedance to the modulator grids. In class AB2 audio, the modulator grids draw current on positive peaks, consequently the driver stage must deliver some power to the grids. By using a low impedance power source, less variation will result between times of load or no load, as the driver swings from positive to negative. The 6CH6 driver feeds the modulator grids through a 2 to 1 step-down transformer, thus further lowering the grid impedance. Two KT88 valves operating class AB2 constitute the modulator stage. They are capable of approximately 120 watts output but are normally operated at the 100 watt level. Series resistors in the grid circuit prevent the grids from swinging too far positive and thus limit the output below the highest obtainable, they also act as parasitic suppressors.

The modulation transformer primary is tapped for 5000 Ω and 7000 Ω anode to anode modulator anode loading.

The KT88 modulator valves in the DX-100U are normally connected to the 5000 Ω taps. As 7000 Ω is higher impedance than normally required some high level clipping will occur in this position, and some operators may prefer this as an alternative tapping position. The transformer is "built out" as a low pass filter and its output permanently by-passed by a .02 μ F capacitor to reduce splatter.

When the transmitter is operated on CW, the CW-phone switch removes the screen voltage from the modulator valves and shorts the secondary of the modulation transformer.

POWER SUPPLIES

The low voltage power transformer contains all of the filament windings, including the filament for the high voltage rectifiers. It also has a tapped secondary to supply the bias rectifier. A 12 volt centre tap winding supplies all of the audio and RF stage filaments. The centre tap is earthed and the 6 volt valves operate from one side or the other side to earth, so as to place a balanced load on both halves of the winding.

The 12AX7 is operated across both halves of the winding. The 12 volt AC secondary may be used to drive existing 12 volt DC relays by using a metal rectifier and filter capacitor. Remember, do not earth either leg as the winding centre tap is permanently earthed. The low voltage supply with a 5U4G rectifier and condenser input filter, delivers 360 volts at 200 mA to the low power audio and RF stages. The taps on the secondary deliver 75 volts to the 6AL5 bias rectifier, also with a condenser input filter. A resistance network on the bias supply applies the correct bias to the final amplifier, modulator and driver stages.

HIGH VOLTAGE POWER SUPPLY

The high voltage supply consists of the main HT transformer, parallel 5R4GY rectifiers, choke input filter and two 125 μ F electrolytic capacitors in series. A centre tapped bleeder balances the series capacitors and also furnishes the modulator screen voltage.

Ordinarily well designed power supplies, using conventional values of paper or oil capacitors, have been found to make violent voltage fluctuations as loads are suddenly applied or removed. This is known as the dynamic regulation characteristic. To eliminate these voltage fluctuations, larger capacitors than are practical in the paper or oil type are necessary. This makes the use of electrolytic types mandatory. The DX-100U uses two 125 μ F 500 volt electrolytic capacitors in series, resulting in a filter capacity of 62.5 μ F at 1000 volts. This is sufficient capacity to assure good dynamic regulation under keying conditions and a fair safety factor on voltage breakdown. The live side of the AC mains input is fused by a cartridge fuse and all circuits entering or leaving the transmitter have LC harmonic filters.



PRELIMINARY NOTES AND INSTRUCTIONS

The Step-by-Step instructions given in this manual should be followed implicitly to ensure a minimum of difficulty during construction and a completely satisfactory result, including many years of accurate, trouble-free service from the finished instrument.

UNPACK THE KIT CAREFULLY, EXAMINE EACH PART AND CHECK IT AGAINST THE PARTS LIST. In so doing, you will become acquainted with the parts. If a shortage is found, attach the inspection slip to your claim and notify us promptly. Screws, nuts and washers are counted mechanically and if a few are missing, please obtain them locally if at all possible.

Lay out all the parts so that they are readily available in convenient categories. Refer to the general information inside the covers of this manual for instructions on how to identify components.

Moulded egg containers make handy trays for holding small parts. Resistors and capacitors may be placed in the edge of a corrugated cardboard box until they are needed.

Use lockwashers under all screws and nuts, and also between controls and the chassis. When shakeproof solder tags are mounted under nuts, the use of lockwashers is unnecessary.

Resistors and capacitors have a tolerance rating of $\pm 10\%$ unless otherwise stated. Therefore a 100 K Ω resistor may test anywhere between 90 and 110 K Ω . Frequently capacitors show an even greater variation such as -50% to +100%. This Heathkit accommodates such variations.

Unless otherwise stated all wire used is insulated. Bare wire is only used where lead lengths are short and there is no possibility of a short circuit. Wherever there is a possibility of the bare wire leads of resistors or capacitors, etc., shorting to other parts or to chassis, such leads must be covered with insulated sleeving.

To facilitate describing the location of parts, all valveholders, controls, tag strips, etc., have been lettered or numbered. Where necessary all such coding is clearly shown in the illustrations.

Valveholders illustrated in the manual are always shown with their tags numbered in a clockwise sequence, from the blank tag position or keyway, when viewed from underneath.

All rotary switch tags are numbered clockwise when viewed from the rear of the wafer, i. e. the end remote from the knob.

All resistors may be wired either way round.

All capacitors, excepting electrolytic capacitors, may be wired either way round unless otherwise stated.

Carefully letter and number tag strips, valveholders, transformers, etc. A wax pencil is ideal for this purpose.

When mounting resistors and capacitors make sure that the value can be read when in position.

Observe polarity on all electrolytic capacitors, i. e. RED = POSITIVE.

A circuit description is included in this manual so that those with some knowledge of electronics will be able to obtain a clearer picture of the actual functioning of this instrument. It is not expected that those with little experience will understand the description completely, but it should be of help in the event that they desire to become more familiar with the circuit operation and thus learn more from building the kit than just the placing of parts and the wiring.

Read this manual right through before starting actual construction. In this way, you will become familiar with the general step-by step procedure used. Study the pictorials and diagrams to get acquainted with the circuit layout and location of parts. When actually assembling and wiring, READ THROUGH THE WHOLE OF EACH STEP so that no point will be missed.

A tick (✓) should be made in the space provided at the beginning of each instruction immediately it has been completed. This is most important as it will avoid omissions or errors, especially whenever work is interrupted in the course of construction. Some Kit-builders have found it helpful in addition to mark each lead in the pictorial in coloured pencil as it is completed.

Successful instrument construction requires close observance of the step-by-step procedure outlined in this manual. For your convenience, some illustrations may appear in large size folded sheets. It is suggested that these sheets be fastened to the wall over your work area for reference purposes during instrument construction.

The Company reserves the right to make such circuit modification and/or component substitutions as may be found desirable, indication being by "Advice of Change" included in the kit.

NOTE: Daystrom Ltd. will not accept any responsibility or liability for any damage or personal injury sustained during the building, testing, or operation of this instrument.

ALL GUARANTEES ARE VOIDED AND WE WILL NOT REPAIR OR SERVICE INSTRUMENTS IN WHICH ACID CORE SOLDER OR PASTE FLUXES HAVE BEEN USED. WHEN IN DOUBT ABOUT SOLDER, IT IS RECOMMENDED THAT ONLY "60/40" RESIN CORE RADIO SOLDER BE PURCHASED.

PROPER SOLDERING PROCEDURE

Only a small percentage of Heathkit purchasers find it necessary to return an instrument for factory service. Of these, by far the largest proportion function improperly due to poor or improper soldering.

Correct soldering technique is extremely important. Good soldered joints are essential if the performance engineered into the kit is to be fully realised. If you are a beginner with no experience in soldering, half an hour's practice with odd lengths of wire and a valveholder, etc., will be invaluable.

Highest quality resin-cored solder is essential for efficiently securing this kit's wiring and components. The resin core acts as a flux or cleaning agent during the soldering operation.

NO SEPARATE FLUX OR PASTE OF ANY KIND SHOULD BE USED. We specifically caution against the use of so-called "non-corrosive" pastes or liquids. Such compounds, although not corrosive at room temperatures, will form residues when heated. These residues are deposited on surrounding surfaces and attract moisture. The resulting compounds are not only corrosive but actually destroy the insulation value of non-conductors. Dust and dirt will tend to accumulate on these "bridges" and eventually will cause erratic or degraded performance of the instrument.

IMPORTANT

IN THE "STEP-BY-STEP" PROCEDURE the abbreviation "NS" indicates that the connection should not yet be soldered, for other wires will be added. At a later stage the letter "S" indicates that the connection must now be soldered.

When two or more connections are made to the same solder tag a common mistake is to neglect to solder the connections on the bottom. Make sure all the wires are soldered.

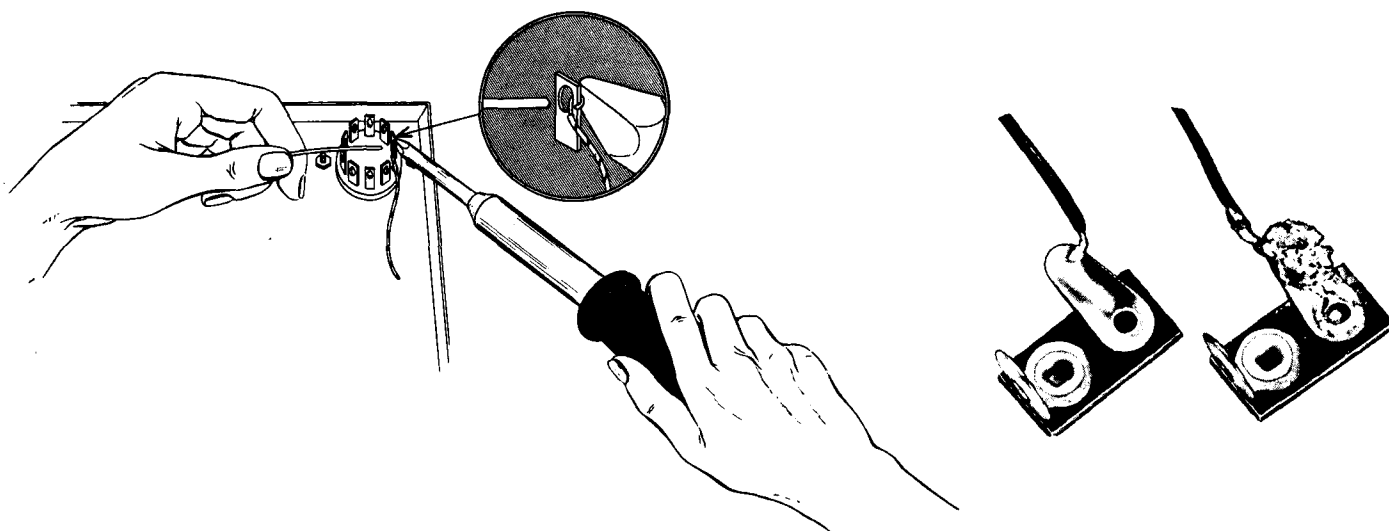

If the tags are bright and clean and wires free of wax, frayed insulation and other foreign substances, no difficulty will be experienced in soldering. Crimp or otherwise secure the wire (or wires) to the terminal, so a good mechanical joint is made without relying on solder for physical strength.

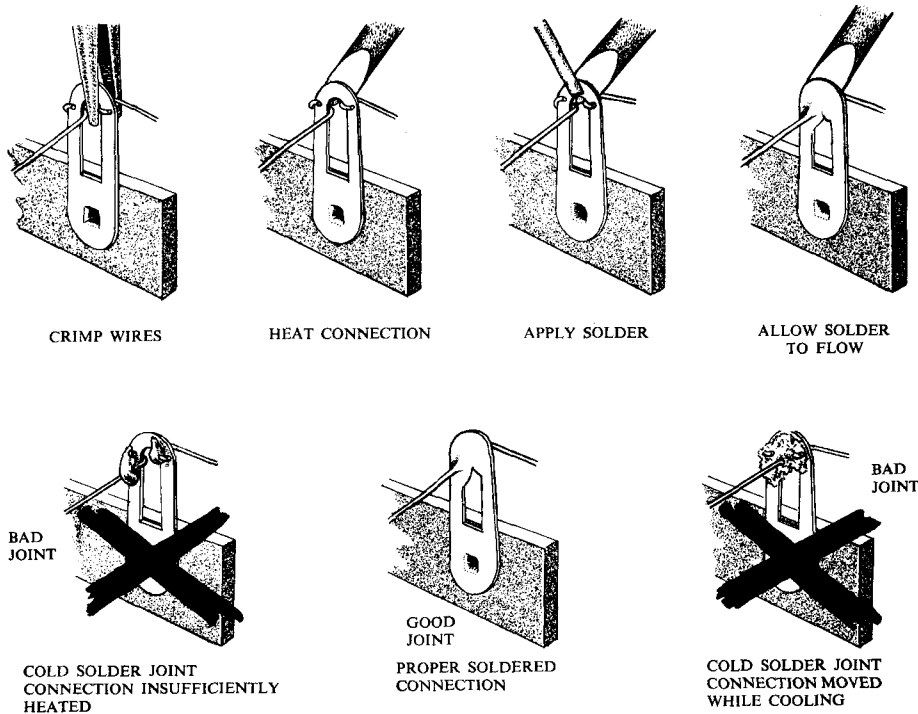

Typical good and bad soldered joints are shown above.

A poor soldered joint will usually be indicated by its appearance. The solder will stand up in a blob on top of the connection, with no evidence of flowing out caused by actual "wetting" of the contact. A crystalline or grainy texture on the solder surface caused by movement of the joint before it solidifies is another evidence of a "cold" connection and possible "dry" joint. In either event, reheat the joint until the solder flows smoothly over the entire junction, cooling to a smooth, bright appearance.

To make a good soldered joint, the clean tip of the hot soldering iron should be placed against the joint to be soldered so that the flat tag is heated sufficiently to melt the solder. Resin core solder is then placed against both the tag and the tip of the iron and should immediately flow over the joint. See illustrations. Use only enough solder to cover the wires at the junction; it is not necessary to fill the entire hole in the tag with solder. Don't allow excess solder to flow into valveholder contacts, ruining the sockets, or to creep into switch sockets and destroy their spring action. Position the work so that gravity tends to keep the solder where you want it.

A clean, well-tinned soldering iron is also important to obtain consistently perfect connections. For most wiring, a 25 to 50 watt iron, or the equivalent in a soldering gun, is very satisfactory. Keep the iron hot and its tip and the connections to be soldered bright and clean. Always place the solder on the heated "work" and then place the bit on top of the solder until it flows readily and "wets" the joint being made. Don't take the solder on to the bit and then try to bring it to the work directly from the soldering iron. Whenever possible a joint should be secured mechanically by squeezing tight with pliers prior to soldering it. The hot soldering bit should frequently be scraped clean with a knife, steel wool or a file, or wiped clean quickly by means of a rag or steel wool.

Don't apply too much solder to the soldered joint. Don't apply the solder to the iron only, expecting that it will roll down onto the connection. Try to follow the instructions and illustrations as closely as possible.

Don't bend a lead more than once around a connecting point before soldering, so that if it should have to come off due to a mistake or for maintenance it will be much easier to remove.

Follow these instructions and use reasonable care during assembly of the kit. This will ensure the deserved satisfaction of having the instrument operate perfectly the first time it is switched on.

ASSEMBLY AND WIRING - VFO SECTION

Make sure if there is an amendment sheet to this Manual, that you have made the alterations at the appropriate places.

On the front face of the VFO sub-chassis near the main bend, mount the slow motion drive unit pin with a 4BA nut and lockwasher on each side. Make sure that the pin threaded end does not protrude beyond the rear nut. See Figures 5 and 6.

Mount the differential tuning capacitor to the VFO sub-chassis as shown in Figure 2. Place a 3/8" lockwasher on the back of the chassis and a 3/8" flat washer and nut on the front. See Figure 3. Align the capacitor so the stator plates appear as shown in Figure 2 before tightening.

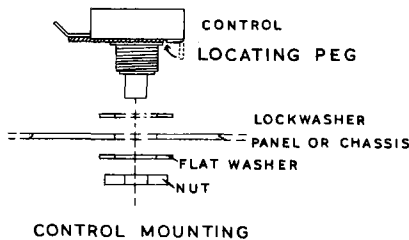

FIGURE 3.

Mount the 160 M coil at the left side of the chassis with its solder tags facing towards the centre as shown in Figure 2. When securing by pressing in the fixing clip, take care not to damage the coil. NOTE: This coil is the one with the larger number of turns.

Mount the 40 M coil in the manner described above. NOTE: This coil is the one with the lesser number of turns.

Mount the two 20 pF variable air spaced trimmers in position, one on each side of the differential tuning capacitor. Secure on the outside with one of the fixing nuts already fitted to each capacitor. Do not use washers. See Figure 2.

Mount the 1.1/16" x 1/4" o.d. 4BA threaded spacer over a solder tag at position in rear of the differential tuning capacitor. Secure from the outside by a 4BA x 1/4" screw passed through a 3-way tagstrip, the chassis, the solder tag, and into the spacer. See Figures 2 and 5.

At the other end of the 1.1/16" spacer, mount a 4BA solder tag. Secure with a 4BA x 1/4" screw.

Insert a 1/4" o.d. rubber grommet to the rear of this assembly.

Mount the 7-pin ceramic (skirted) valveholder from above the chassis, position as shown in Figure 2 and secure with 6BA x 1/4" hardware.

Mount a 4-way tagstrip as shown in Figure 2, secure with 4BA x 1/4" hardware.

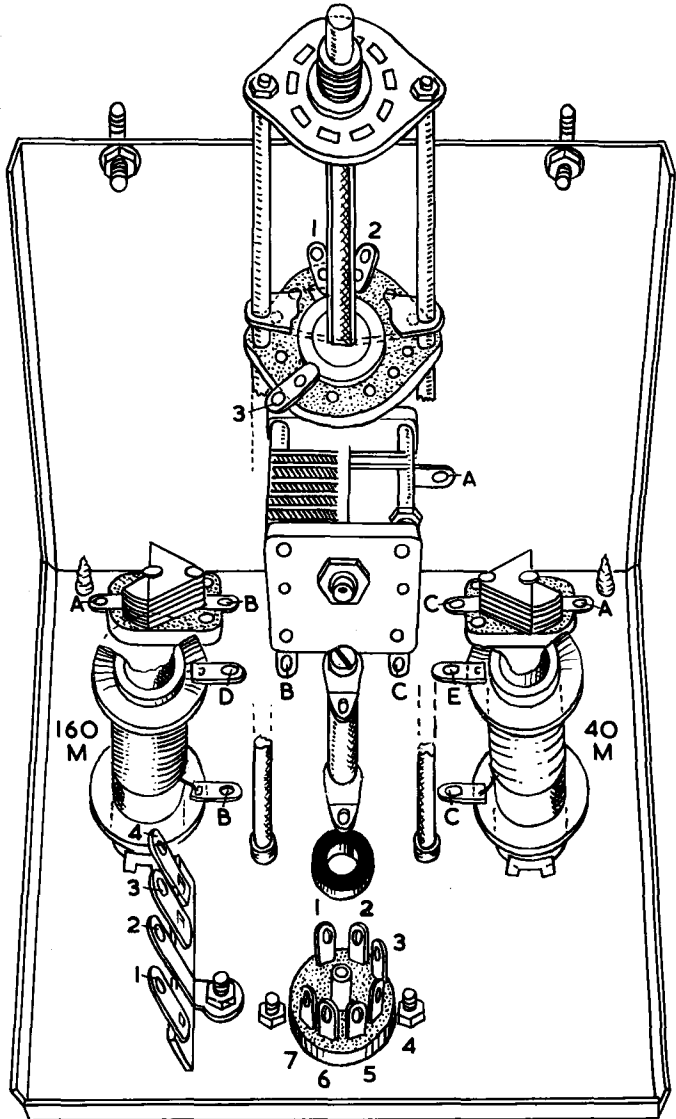

FIGURE-2.

NOTE: Two gauges of bare wire are supplied with this kit. Always use the smaller gauge wire except when the heavy gauge wire is called for.

Connect a length of bare wire from the left hand 20 pF trimmer rotor tag A (NS) to the differential tuning capacitor rotor tag A (NS). See Pictorial 1.

Connect a length of similar bare wire from the left hand trimmer rotor tag A (S) to the 4-way tagstrip 2 (NS).

Connect a length of bare wire between differential capacitor rotor tag A (S) and the right hand 20 pF trimmer rotor tag A (NS).

Connect a bare wire from this rotor tag A (S) to the solder tag at the base of the 1.1/16" x 1/4" o.d. spacer (NS) and on through the 4-way tagstrip, tag 2 (NS).

Now pass another bare wire through the upper solder tag on the spacer (NS), the lower solder tag (S), the miniature 7-pin valveholder pin 3 (NS) and the valveholder centre shield (S). See Pictorial 1 and check wiring so far completed.

Run a bare wire through tag B of the 160 M coil (NS) then through tag B of the differential capacitor to point B of the 20 pF trimmer capacitor. Solder the connections on the two capacitors and make a mechanical connection at the coil tag (NS).

Run a bare wire from tag C on the 40 M coil (NS) through tag C on the differential capacitor to point C on the right hand trimmer capacitor. Solder the connections on the two capacitors. See Pictorial 1.

NOTE: In the next six steps, the components should be mounted with very short leads. First, however, examine Pictorial 1 and note that the components must be so placed as to clear the switch which will be mounted later.

Wrap the leads of a 47 pF silver mica capacitor around the leads of a 10 pF ceramic capacitor as shown in Figure 4. Solder quickly with a hot iron to prevent damage to the capacitor. (This capacitor may be colour coded VIOLET, BROWN, BLACK, BLACK, BROWN.)

Connect the 10 pF ceramic capacitor from tag B on the 160 M coil (S) to the top solder tag on the 1.1/16" spacer (NS).

Wrap the leads of a 47 pF silver mica capacitor around the leads of a 4.7 pF ceramic capacitor and solder as in previous step. (The 4.7 pF capacitor may be colour coded VIOLET, YELLOW, VIOLET, WHITE, BROWN.)

Connect this assembly from tag C on the 40 M coil (S) to the top solder tag on the 1.1/16" spacer (NS).

Connect a 22 K Ω 1/2 watt resistor (RED, RED, ORANGE) from the top solder tag on the spacer (NS) to tag D of the 160 M coil (NS).

Connect a 2.2 K Ω 1/2 watt resistor (RED, RED, RED) from the top solder tag on the spacer (S) to tag E of the 40 M coil (NS).

Mount the VFO switch with the long studs through the 1/8" holes in the top of the chassis, using the hardware supplied with the switch. Note the position of the switch contacts in Pictorial 1 when mounting.

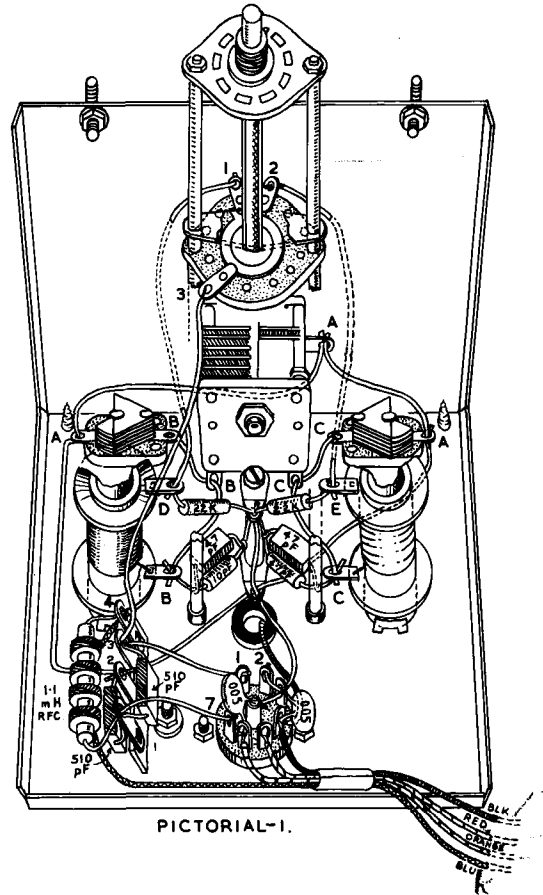

PICTORIAL-1.



FIGURE-4.

Connect a short bare wire from switch tag 1 (S) to the 160 M coil tag D (S).

Connect a short bare wire from switch tag 2 (S) to the 40 M coil tag E (S).

Connect a 510 pF silver mica capacitor from tag 2 on the 4-way tagstrip (S) to tag 1 on the tagstrip (NS).

Connect a 510 pF silver mica capacitor from tag 1 on the tagstrip (NS) to tag 3 (NS).

Connect a bare wire from tag 3 on the switch (S) to tag 3 on the tagstrip (NS).

Connect a bare wire from tag 3 on the tagstrip (S) to pin 1 on the valveholder (S).

Connect a bare wire from tag 1 on the tagstrip (NS) to pin 7 on the valveholder (S).

Connect a 4 pi, 1.1 mH RF choke from tag 1 on the tagstrip (S) to tag 4 (NS).

Connect a BLUE wire, 11" long, to tag 4 (S). Leave the other end free.

Cut both leads of a .005 μ F disc ceramic capacitor to $\frac{1}{2}$ " length. Connect one lead to the centre shield of the valveholder (S).

Connect the other lead to pin 6 on the valveholder (NS).

Connect one end of an ORANGE wire, 8" long, to pin 6 (S). Leave the other end free.

Connect one end of a RED wire, 7" long, to pin 5 (S). Leave the other end free.

Mount the dial lampholder as shown in Figure 20, with the rear contact towards tag 3 of the 3-way tagstrip. Bind it to the tag with a short piece of bare wire around tag 3 (S) and strap this wire across to tag 2 (S).

Connect a BLACK wire from the valveholder pin 4 (NS). Run the wire through the $\frac{1}{4}$ " o.d. grommet and connect to the 3-way tagstrip tag 1 (S). Solder all three tags on this tagstrip now. See Pictorial 1 and Figure 20.

Cut one lead of a .005 μ F disc ceramic capacitor to $\frac{5}{8}$ " length and the other lead to $\frac{3}{8}$ " length.

Run the $\frac{5}{8}$ " lead through pin 3 of the valveholder to pin 2. Solder both connections.

Connect the $\frac{3}{8}$ " lead to pin 4 (NS).

Connect the end of a BLACK wire, 8" long, to pin 4 (S). Leave the other end free.

Gather the four loose wires together at a point just behind the valveholder and secure with scotch tape or twine as shown in Pictorial 1.

Mount the tuning dial to the slow motion drive unit, use 8BA screws and washers, do not overtighten. Check that dial reads correctly when viewed from the front. See Figure 6.

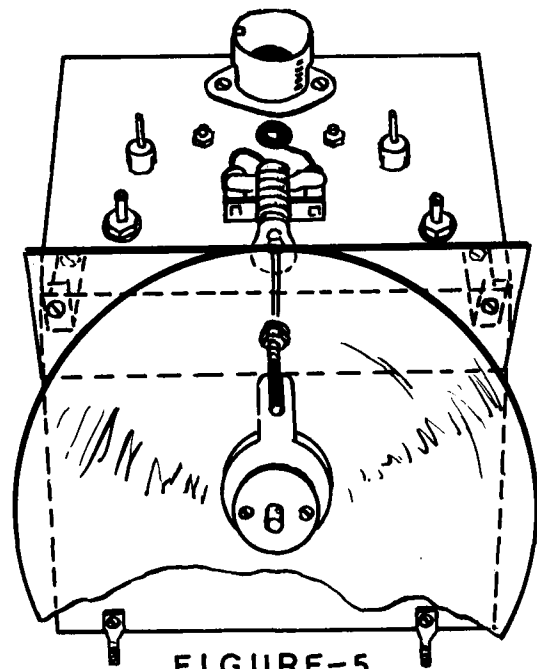

FIGURE-5.

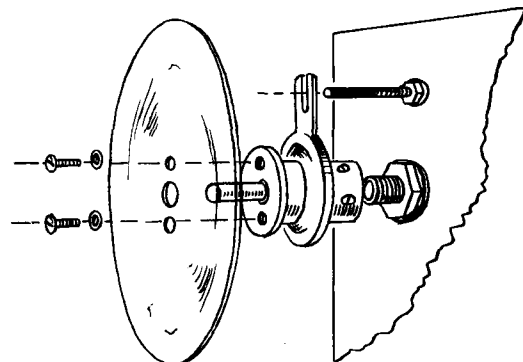

FIGURE-6.



Fit the slow motion drive unit and tuning dial to the differential tuning capacitor shaft and press the slotted flange over the drive unit pin already mounted to the sub-chassis, do not secure yet. See Figures 5 and 6.

Mount the green plastic light shield to the small aluminium brackets using 4BA x $\frac{1}{4}$ " hardware. See Figure 5.

Mount the light shield behind the tuning dial and secure with two small self-tapping screws. See Figure 5.

Carefully move the tuning capacitor rotor plates around till they are fully meshed in the large stator section. Rotate tuning dial until index mark to the left of 7000 Kc/s is in line with light shield slot. Secure drive unit to tuning capacitor by tightening the two grub screws. See Figure 6.

Mount two 4BA eye bolts to the bottom of chassis flange as shown in Figure 2. Use 6BA x $\frac{1}{4}$ " hardware.

Temporarily set this unit aside.

ASSEMBLY AND WIRING OF CHASSIS BASE

Insert 5/8" rubber grommets in holes A, B, C and D. See Pictorial 2.

Insert a 3/8" rubber grommet in hole E.

Mount a 3-way tagstrip AA in the hole adjacent to this grommet, using a 4BA x $\frac{1}{4}$ " countersunk head screw and lockwasher under the nut. Position as shown in Pictorial 2.

Mount a 4-way tagstrip BB on the side of the chassis to the left of the 3-way tagstrip, using 4BA x $\frac{1}{4}$ " hardware. Position as shown. Include a solder tag under the fixing nut.

Mount a 5-way tagstrip CC in the next two holes in the chassis. Position as shown.

Mount a 4-way tagstrip DD in the next hole forward. Position as shown.

Mount a 3-way tagstrip EE in the next hole forward. Position as shown.

Mount the 5-way tagstrip FF, using the two holes in the chassis side as shown.

Mount a 5-way tagstrip GG using the next two holes in the chassis side as shown.

Mount the coaxial socket on the outside rear of the chassis at position AS using 6BA x $\frac{1}{4}$ " hardware. Include a solder tag under the nut shown.

Mount a 2BA x $\frac{1}{2}$ " screw through the hole adjacent to the socket. Include a lockwasher and two nuts outside the chassis.

Using 4BA x $\frac{1}{4}$ " hardware, mount a ceramic octal valveholder in the rear of the chassis with the keyway toward the centre. Include a solder tag at fixing hole near tag 8. See Pictorial 2.

Mount the 5-way tagstrip HH on the side of the chassis next to the socket. In mounting, place solder tags between the chassis and the tagstrip feet and lockwashers under the nuts. Position the solder tags as shown in Pictorial 2.

Loosely mount one DPST toggle switch in hole M, first screwing the hex nut all the way back on the shaft. The slot in the shaft must be toward the top of the chassis. Mount the other toggle switch in hole H in the same manner. Use the hardware supplied with the switches. Place the lockwashers on the inside.

Loosely mount the 3-pole 2-position rotary CW-phone switch in hole N, using a 3/8" lockwasher behind the chassis and a flat washer and control nut in front. Position as shown in Pictorial 2.

Mount a .5 megohm potentiometer in hole G in the same manner. (Metal shaft.)

Mount the microphone socket to the inside of the chassis front at position F. Use 6BA x 5/16" hardware (with countersunk screw heads).

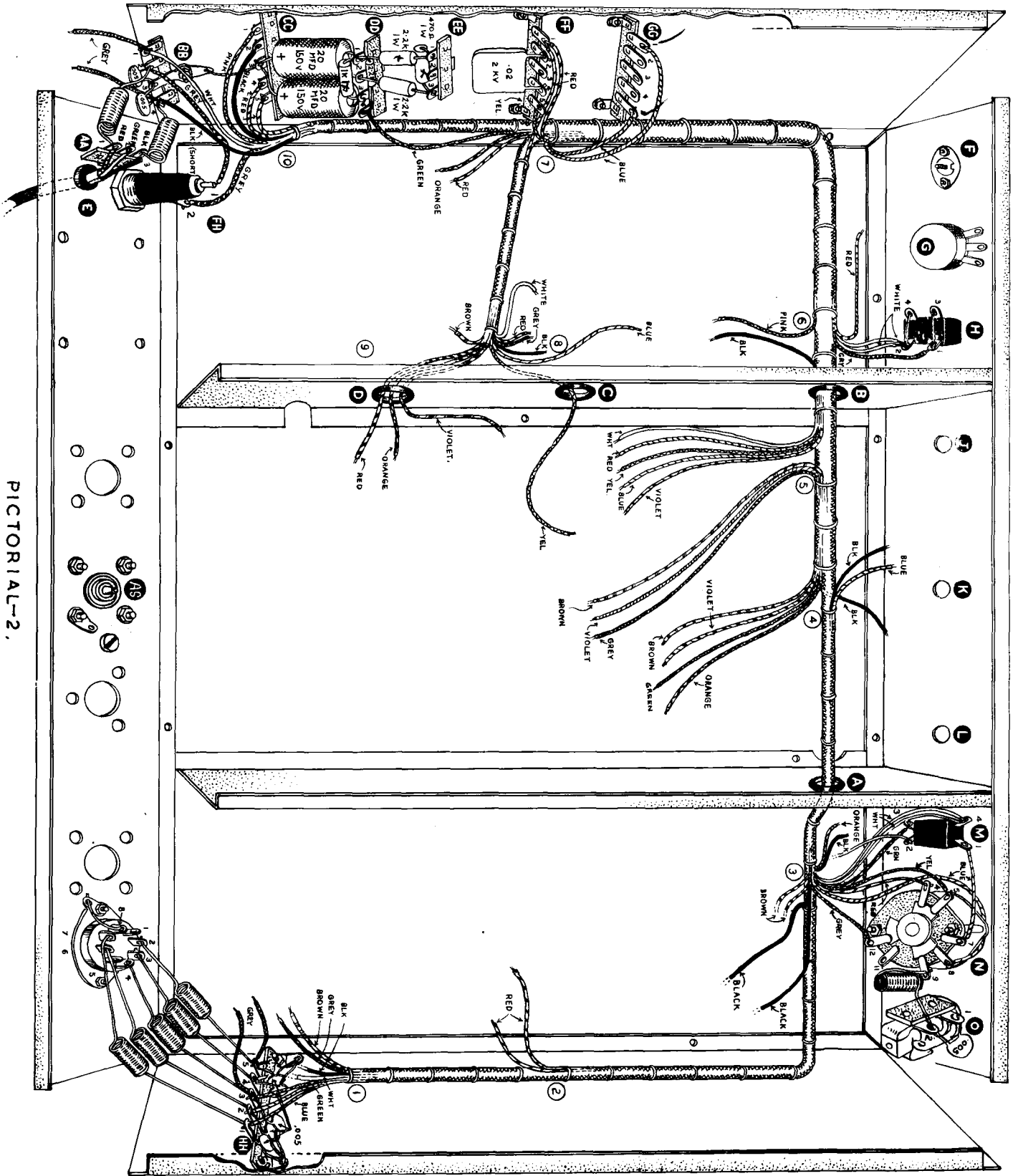

PICTORIAL-2.



Mount the key jack in hole O. Before mounting, discard the inner 3/8" nut. Mount with the fibre spacer and lockwasher on the inside and outer fixing nut and flat washer on the outside.

NOTE: The nuts and flat washers on the controls must be removed to mount the panel, so tighten just sufficiently to hold them in place for wiring in the position shown in Pictorial 2. Extra holes in base are for converting the DX-100U to single sideband incorporating the SSB Adaptor at a later date.

Cut the leads of a .005 μ F disc ceramic capacitor to $\frac{1}{2}$ " and connect between tag 3 of BB (NS) and tag 4 of BB (NS).

Cut the leads of a .005 μ F disc ceramic capacitor to $\frac{1}{2}$ " and connect between tag 2 of BB (NS) and tag 3 of BB (S).

Connect a mains filter choke (20 turns of enamel wire) between tag 1 of tagstrip AA (NS) and tag 2 of BB (NS).

Connect a mains filter choke between tag 3 of AA (NS) and tag 4 of BB (NS).

Connect the positive side of a 20 μ F 150 volt electrolytic capacitor (side marked +) to tag 3 of tagstrip CC (NS).

Connect a short piece of bare wire from tag 3 of CC (NS) to the solder tag at BB (S).

Connect the negative side to tag 1 of DD (NS).

Connect the positive side of a 20 μ F 150 volt capacitor to tag 3 of CC (S).

Connect the negative side to tag 3 of DD (NS).

Connect a 1 K Ω 1 watt resistor (BROWN, BLACK, RED) from tag 1 of DD (NS) to tag 3 of DD (NS).

Connect a 470 Ω 1 watt resistor (YELLOW, VIOLET, BROWN) from tag 1 of EE (NS)

Connect a 2.2 K Ω 1 watt resistor (RED, RED, RED) from tag 1 of DD (NS) to tag 1 of EE (NS).

Connect a 2.2 K Ω $\frac{1}{2}$ watt resistor (RED, RED, RED) from tag 1 of DD (S) to tag 4 of DD (NS).

Connect a 2.2 K Ω 1 watt resistor (RED, RED, RED) from tag 3 of EE (NS) to tag 2 of DD (S)

Connect a .02 μ F 2 kv disc ceramic capacitor from tag 2 of FF (NS) to tag 4 of FF (NS).

NOTE: Keep the leads on the capacitor short and make sure that they do not touch the chassis or other tags.

Connect a .005 μ F disc ceramic capacitor from the earth solder tag adjacent to tag 1 of tagstrip HH (NS) to tag 1 of HH (NS).

Connect a .005 μ F disc ceramic capacitor from the same solder tag (NS) to tag 2 of HH (NS).

Connect a .005 μ F disc ceramic capacitor from the same solder tag (S) to tag 3 of HH (NS).

Connect a .005 μ F disc ceramic capacitor between tag 5 of tagstrip HH (NS) and the adjacent earth solder tag (NS).

Connect a .005 μ F disc ceramic capacitor from the same earth solder tag (S) to tag 4 of HH (NS).

Connect a mains filter choke from tag 5 of HH (NS) to pin 2 of the ceramic valveholder (S).

Connect a mains filter choke from tag 4 of HH (NS) to pin 3 of the valveholder (S).

Connect a mains filter choke from tag 3 of HH (NS) to pin 4 of the valveholder (S).

Connect a mains filter choke from tag 2 of HH (NS) to pin 6 of the valveholder (S).

Connect a mains filter choke from tag 1 of HH (NS) to pin 7 of the valveholder (S).

Connect a bare wire from pin 8 of the valveholder (S) to the adjacent earth solder tag (S).

Cut the leads of a .005 μ F disc ceramic capacitor to $\frac{1}{2}$ ". Connect the one lead to tag 2 of the key jack O (NS). Connect the other lead to tag 1 (S).

Connect a small mains filter choke from tag 2 of the key jack (S) to tag 9 of the CW-phone switch N (S). (This choke is wound on a tufnol rod and indicated by a WHITE spot.)

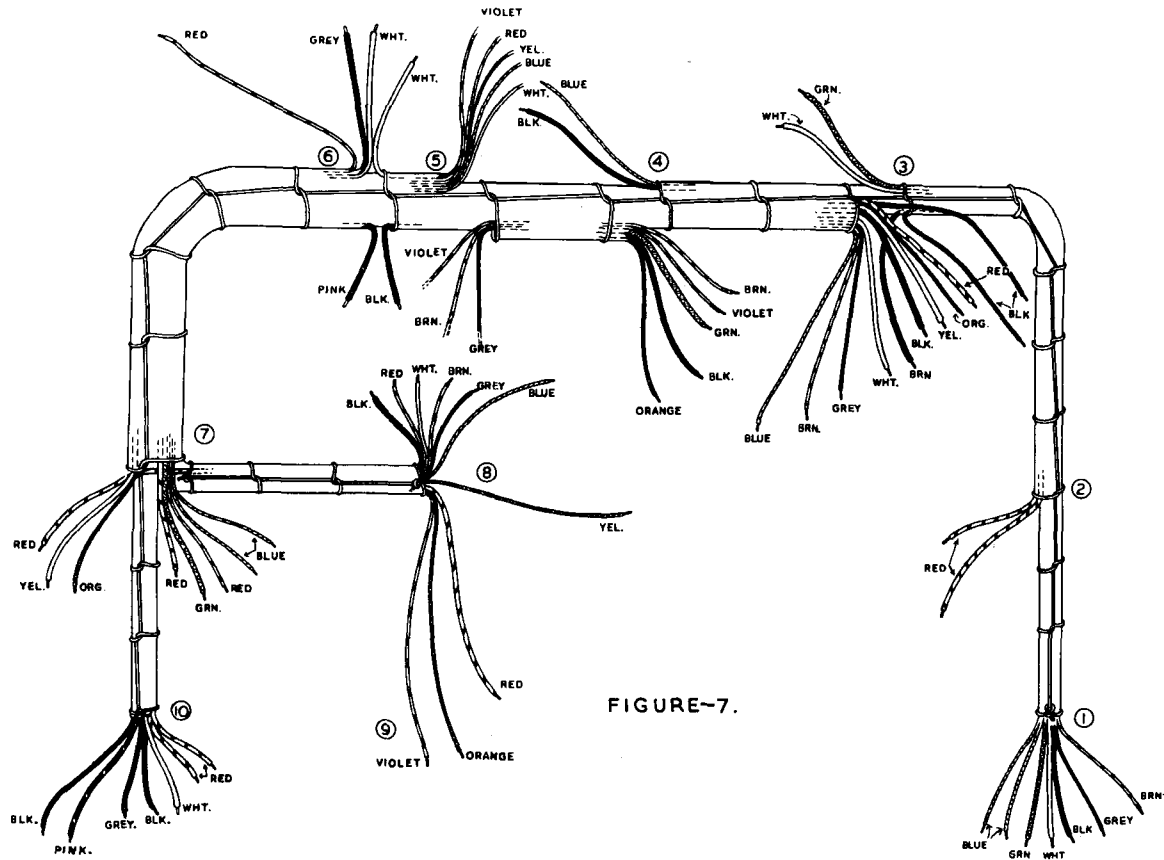

NOTE: The cable must be run through grommets A and B in the chassis frame. Some care must be exercised to prevent damage to the cable. In general, the leads should be made to lie flat along the cable in the direction they normally are going. Lay the chassis flat so that it appears as in Pictorial 2. Select the end of the cable that has seven leads; BLACK, two BLUE, GREY, WHITE, GREEN and BROWN. See Figure 7. Start this end through grommet B from the left side, then through grommet A. As the various breakout points approach the grommets, guide the loose wires against the cable and through the grommet. Continue this process until harness points 1, 2 and 3 are in the right hand compartment, points 4 and 5 in the centre compartment and 6, 7, 8, 9 and 10 are in the left hand compartment. In the left and right hand compartment, guide the cable along the flange and against the sides of the chassis as shown. In wiring the cable, turn the chassis in the position most convenient for the section being wired.

At point 1 of the cable, connect either BLUE lead to tag 1 of HH (S).

Connect the other BLUE lead to tag 2 of HH (S).

Connect the GREEN lead to tag 3 of HH (NS).

Connect the WHITE lead to tag 4 of HH (S).



Connect the BLACK lead to tag 5 of HH (NS).

NOTE: Make sure none of the capacitors, mains filter chokes or tags are shorted to each other or to the chassis.

At point 3 of the harness, connect the GREEN wire to tag 3 of the toggle switch M (NS).

Connect a bare wire $3\frac{1}{2}$ " long to tag 2 of the toggle switch M (S). Leave the other end free.

Connect the two WHITE wires to tag 4 of the toggle switch M (S).

Connect the BLUE wire to tag 8 of the CW-phone switch N (S). Run the wire as shown in Pictorial 2.

Cut a piece of BLUE wire $3\frac{1}{2}$ " long. Connect one end to tag 7 of switch N (S) and the other end to tag 1 of switch M (NS).

Connect the RED wire to tag 4 of switch N (S).

Connect the YELLOW wire to tag 5 of switch N (NS).

Connect the GREY wire to tag 12 of switch N (S).

At point 6 on the cable, connect the GREY wire through tag 1 to tag 3 of the toggle switch H. Solder both tags.

Connect one WHITE wire to tag 2 of H (NS).

Connect the other WHITE wire through tag 4 (S) to tag 2 (S).

At point 7 on the cable, connect the YELLOW wire to tag 5 of the tagstrip FF (NS).

Connect the two short heavily insulated RED wires to tag 1 of FF (NS). At this point, there is a smaller diameter longer RED wire which will be connected later.

Connect the GREEN wire to tag 4 of tagstrip DD (S).

Connect either BLUE wire to tag 1 of tagstrip GG (NS).

Connect the other BLUE wire to tag 5 (NS).

NOTE: These wires on the tagstrip GG connect to the octal valveholder on the rear of the chassis. No further connection will be made to them now as they are used only when it is desired to obtain audio output from the transmitter. This operation will be explained later.

At point 10 on the harness, connect either RED wire to tag 5 of the tagstrip CC (NS).

Connect the other RED wire to tag 4 (NS).

There is one long BLACK wire and one short BLACK wire at this point in the cable. Connect the short BLACK wire to tag 4 of tagstrip BB (NS). Connect the long BLACK wire to tag 2 of CC (NS). Connect the PINK wire to tag 1 of tagstrip CC (NS).

Connect the WHITE wire to tag 1 of BB (NS).

Run the YELLOW wire at point 8 on the cable through grommet C and the RED, ORANGE and VIOLET wire at point 9 on the cable through grommet D.

Connect one end of a 5" piece of GREY wire to tag 1 of BB (S), leave the other end free.

Connect one end of another piece of GREY wire 5" long to tag 4 of BB (S), leave the other end free.

Set the chassis aside for the time being.

CHASSIS TOP PLATE ASSEMBLY AND WIRING

NOTE: The holes in this section are too numerous to be designated by a numbering or letter system and some of the holes are merely for ventilation. Consequently the assembly must be performed by paying strict attention to Figure 8 and Pictorials 3 and 4. The large components will be mounted first and the rest of the parts located by their relationship to them. A grid system has been included in some Pictorials to assist assembly.

Refer to Figure 8 for the following assembly.

Turn the chassis top plate until the two largest holes are towards the rear and to the right of centre. In mounting miniature valveholders locate the pin positions by noting the position of the blank pin space. Octal valveholders are positioned by the central keyway direction. All valveholders are numbered clockwise on the valveholder underside from the blank pin position.

Using 4BA x $\frac{1}{4}$ " hardware, mount on the chassis underside the following components.

To the left of centre, mount the two 5R4GY octal valveholders, reference grid A2 and B2.

To the right of centre, mount the 5U4G and the two KT88 valveholders in positions shown. Mount a 1-way tagstrip under the rear KT88 fixing nut nearest to the 5U4G valveholder. Reference grid F2.

Using 6BA x $\frac{1}{4}$ " hardware, mount to the chassis topside the following components.

NOTE: When solder tags are mounted under fixing nuts, lockwashers are not required.

On the right hand side, mount two miniature 7-pin valveholders at position 6AL5 and OA2. Reference grid F2.

To the left of centre nearest the front edge, mount another 7-pin valveholder in position 6AQ5. Reference grid B5.

Near the chassis centre, mount two miniature 9-pin valveholders at position 6CH6 and 5763. Under each fixing nut mount two 6BA solder tags. Reference grid C3 and D3.

Near the front edge, mount two miniature 9-pin valveholders at positions 6CH6 and 12AX7. Include two solder tags under each fixing nut. Reference grid E5 and F5.

From above the chassis, mount the two insulated electrolytic capacitor mounting wafers at positions near the 6AQ5 valveholder. Under the mounting nut and lockwasher nearest to the corner of the chassis, mount a 1-way tagstrip. Mount a solder tag under the fixing nut nearest to the 6AQ5 valveholder. See Figure 8. Reference A5 and B5.

To the left of the 5U4G valveholder, mount the non-insulated electrolytic capacitor mounting wafer. Use 6BA x $\frac{1}{4}$ " hardware. Reference grid E2.

Install the six $\frac{3}{8}$ " rubber grommets shown in Figure 8. Reference grid A5, C4, D3, D4, D5 and E5.

Mount the small audio drive transformer Part No. 51-506 using 4BA x $\frac{1}{4}$ " countersunk head hardware. Ensure that the one BLACK and two GREEN leads are nearest the two KT88 valveholders. Reference F3.

Mount the audio section shield plate in the holes nearest the 12AX7 and 6CH6 valveholders. Using 4BA x $\frac{1}{4}$ " hardware. Include a solder tag under the fixing nut at the mounting hole near the chassis edge. Ensure that the mounting lip of the plate is towards the KT88 valveholders.

See Figure 8 and mount the two 4BA solder tags on the audio shield plate using 4BA x $\frac{1}{4}$ " screws and nuts. Position as shown. Reference grid E4 and F4.

Using 4BA x $\frac{1}{4}$ " hardware, mount a 4-way tagstrip in the remaining hole in the shield plate. Reference grid F4.

Using 4BA x $\frac{1}{4}$ " countersunk headed screws, mount two 5-way tagstrips underneath the chassis using the countersunk fixing hole near the right hand rear corner of the chassis and nuts and lockwashers over the tagstrips and mounting feet. Reference grid F1.

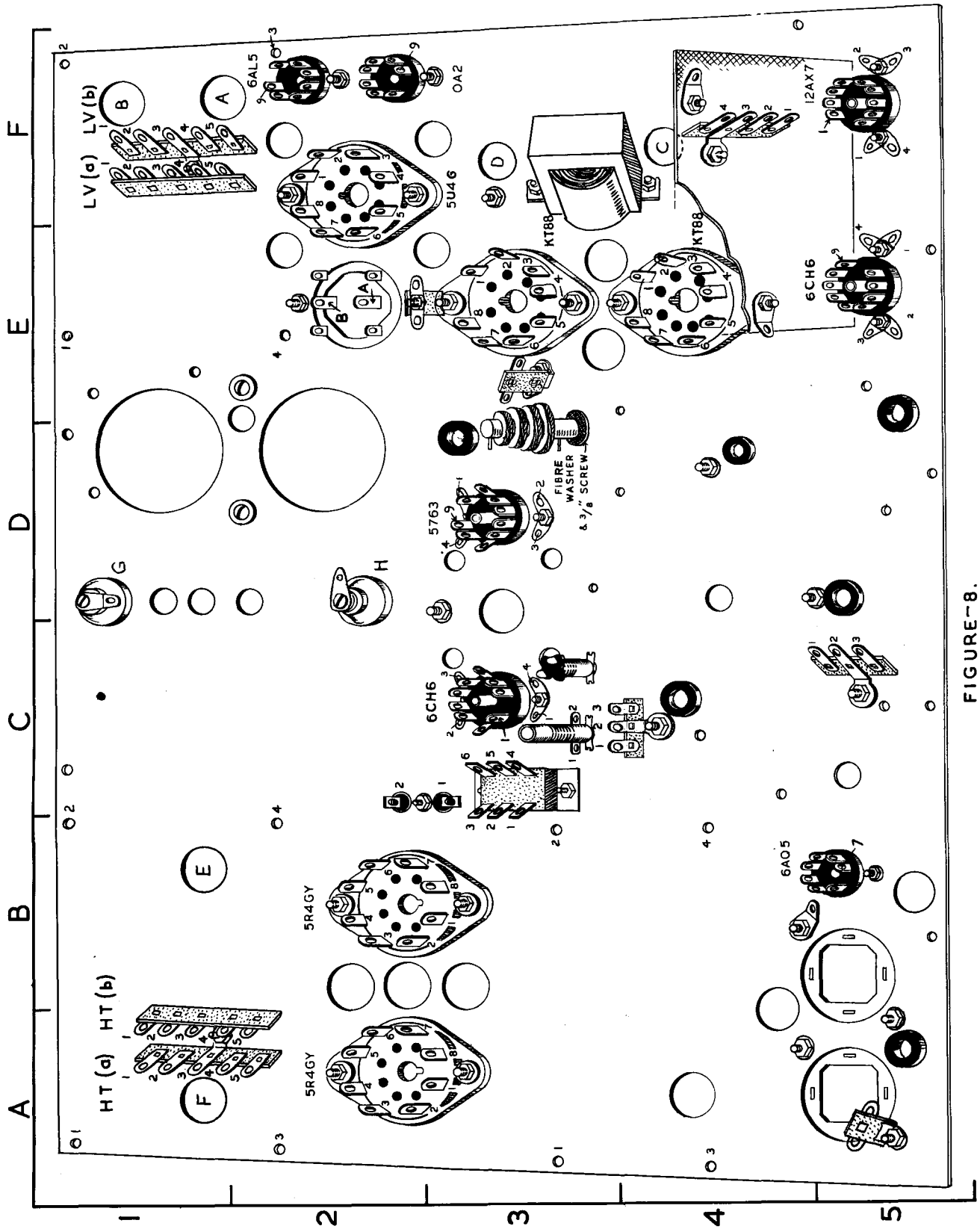

FIGURE-8.

Using similar hardware and tagstrips repeat the previous step using the countersunk fixing hole near the left hand rear corner of the chassis. Reference grid A1.

See Pictorial 4 and mount a 4-way tagstrip using 4BA x $\frac{1}{4}$ " hardware at the hole directly in rear of the grommet positioned to the right of the front KT88 valveholder.

Between the 5763 and the rearmost KT88 valveholder, there is a group of three holes in a triangular formation. At the hole nearest the front edge of the chassis plate, mount a 2.5 mH choke. Position the tags as shown in Figure 8. Use a 4BA x $\frac{3}{8}$ " screw with a lockwasher underneath the screwhead and a fibre washer between the choke and chassis plate. Reference grid D3.

Select the $\frac{1}{4}$ " wide variable capacitor mounting bracket and mount on top of the chassis using the other two holes of this group. Ensure that the mounting lip is towards the front of the chassis plate and away from the choke. Use 4BA x $\frac{1}{4}$ " screws. Under the head of the screw nearest the 5763 valveholder, insert a 4BA solder tag. On the other screw fit a solder tag and a 1-way tagstrip underneath the nut. Position as shown in Figure 8 and Pictorial 4.

Mount a 5-way tagstrip on top of the chassis behind the front centre $\frac{3}{8}$ " grommet as shown in Pictorial 4. Use 4BA x $\frac{1}{4}$ " hardware.

In front of the 6CH6 valveholder are two $\frac{5}{16}$ " holes, reference grid C3, mount the slug tuned coils in these holes from the bottom side of the chassis. Mount the larger coil on the left. Gently press the coils into the holes until the two retaining ears click into position on the other side of the hole.

To the front of these coils is a $\frac{3}{8}$ " grommet with a small hole behind it. Mount a 3-way tagstrip at this position as in Figure 8. Use 4BA x $\frac{1}{4}$ " hardware. Reference grid C4.

From above the chassis mount the crystal socket in the hole to the left of the 6CH6 valveholder. Use a 6BA x $\frac{5}{8}$ " cheese head screw and nut only. Reference grid C2.

In the hole in front of the crystal socket mount the DPDT slide switch. Use 6BA x $\frac{1}{4}$ " screws and nuts. DO NOT use lockwashers. Reference grid C3.

Near the front centre of the chassis are two holes positioned close together. Using the hole nearest the centre mount a 3-way tagstrip. Use 4BA x $\frac{1}{4}$ " hardware. Reference grid C5.

PARTIAL WIRING

NOTE: In later assembly the chassis top plate will be fitted to the chassis base frame. Therefore the positioning of wires and components must be within certain limits. To save trouble in the final assembly it is advisable to temporarily place the top plate in position on the frame and draw a pencil line on the top plate around the inside of the frame. These will act as reference lines and wires and components must be kept clear of them.

AUDIO SECTION WIRING

All resistors used will be $\frac{1}{2}$ watt unless otherwise stated.

CAUTION: Ensure that none of the wiring in section will foul the chassis base plate or shield when these are mounted. Also that components around the front 6CH6 valveholder will not be in contact with the MAINS ON/OFF switch.

At the 12AX7 valveholder (reference F5) pass a $5\frac{1}{2}$ " length of 22 swg. bare wire through earth tag 4, pin 9 to the centre shield. Solder the earth tag and centre shield only. See Pictorial 3. Leave the other end free.

Cut both leads of a .005 μ F disc capacitor to $\frac{1}{4}$ ". Connect one lead to pin 9 (S) and the other to pin 8 (NS).

Cut the leads of a 4700 Ω resistor (YELLOW, VIOLET, RED) to $\frac{1}{2}$ ". Connect one lead to pin 8 (NS) and the other to earth tag 1 (NS).

Cut one lead of a 470 K Ω resistor (YELLOW, VIOLET, YELLOW) to $\frac{3}{8}$ " and connect to pin 7 (NS).

Connect the other lead to earth tag 2 (S). Position as shown in Pictorial 3.

Cut the leads of a 4700 Ω resistor (YELLOW, VIOLET, RED) to $\frac{3}{8}$ ". Connect one lead to earth tag 3 (S) and the other lead to pin 3 (NS).



Connect a length of BLACK wire to pin 4 of the 12AX7 valveholder (S), (reference F5). Run the wire close to the chassis and audio shield plate to pin 4 of the 6CH6 valveholder (NS).

Connect another length of BLACK wire from pin 5 of 12AX7 valveholder (S) to pin 7 of the front KT88 valveholder (NS) (reference E4).

Connect a .1 μ F 400 volt paper capacitor between the left hand solder tag on the audio shield plate (NS) and tag 1 of the 4-way tagstrip (NS). See Pictorial 3.

Connect another .1 μ F 400 volt paper capacitor between the left-hand solder tag (S) and tag 2 of the tagstrip (NS).

Bend the leads of a 100 K Ω resistor (BROWN, BLACK, YELLOW) so that it may be connected as shown in Pictorial 3. Connect between tag 2 of the tagstrip (NS) and tag 4 (NS).

Bend the leads of a 47 K Ω resistor (YELLOW, VIOLET, ORANGE) in the same manner and connect between tag 1 (NS) and tag 4 (NS) on the tagstrip.

Coming from the primary of the driver transformer are a RED lead and a YELLOW lead. Run the RED lead close to the chassis around the audio shield plate and connect to tag 4 of the tagstrip (NS). See Pictorial 3.

Connect the negative lead of the 2 μ F 50 volt electrolytic capacitor to earth tag 1 on the 12AX7 valveholder (S).

Connect the other lead (positive) to pin 3 of the 6CH6 valveholder (reference E5) using sleeving (NS).

Select a 510 pF mica capacitor. Connect one lead to pin 1 of the 12AX7 valveholder (NS) and the other lead to pin 2 of the 6CH6 (NS). Use sleeving on both leads.

Cut both leads of a 100 K Ω resistor (BROWN, BLACK, YELLOW) to 5/8". Connect one lead to pin 1 of the 12AX7 valveholder (S) and the other lead to tag 1 on the tagstrip (S).

Cut a 4" length of GREEN wire, prepare both ends. Connect one end to pin 2 on the 12AX7 valveholder (S). Leave the other end free.

Connect the negative lead of a 2 μ F 50 volt electrolytic capacitor to the solder tag at the top right hand corner of the shield plate (NS). Place as shown in Pictorial 3.

Connect the positive lead to pin 8 of the 12AX7 valveholder using sleeving (S). Ensure that no short circuits exist to other connections.

Connect the negative lead of a 2 μ F 50 volt electrolytic capacitor to the same solder tag (S) and the positive lead to pin 3 of the 12AX7 valveholder (S). Ensure that it is clear of all other connections and chassis.

Cut both leads of a 470 K Ω resistor (YELLOW, VIOLET, YELLOW) to 7/8". Connect one lead to pin 6 of the 12AX7 valveholder (NS) and the other lead to tag 2 of the tagstrip (S).

Slip a 1" length of sleeving over one lead of a 510 pF mica capacitor and connect this lead to pin 6 of the 12AX7 valveholder (S). Leave the other end free.

Slip a 5/8" length of sleeving over one lead of a 4700 Ω resistor (YELLOW, VIOLET, RED). Connect this lead to pin 7 of the 12AX7 valveholder (S). Leave the other end free.

Cut one lead of a 680 Ω resistor (BLUE, GREY, BROWN) to 7/8". Bend a Z shape in the lead close to the resistor as shown in Pictorial 3. Run this lead through pin 9 of the 6CH6 (reference E5) to the adjacent earth tag. Solder both connections.

Cut the other lead to 5/8" and, using sleeving, connect to pin 3 (S).

Cut one lead of a 470 K Ω resistor (YELLOW, VIOLET, YELLOW) to 1/2" and connect to pin 2 (S).

Bend the other lead back to earth tag 2 (S).

Bring the YELLOW driver transformer lead around the audio shield plate and cut the lead to length to reach pins 7 and 8 of the 6CH6 valveholder. Strip the lead 1/2" and pass the stripped end through pin 7 to pin 8. Solder both connections.

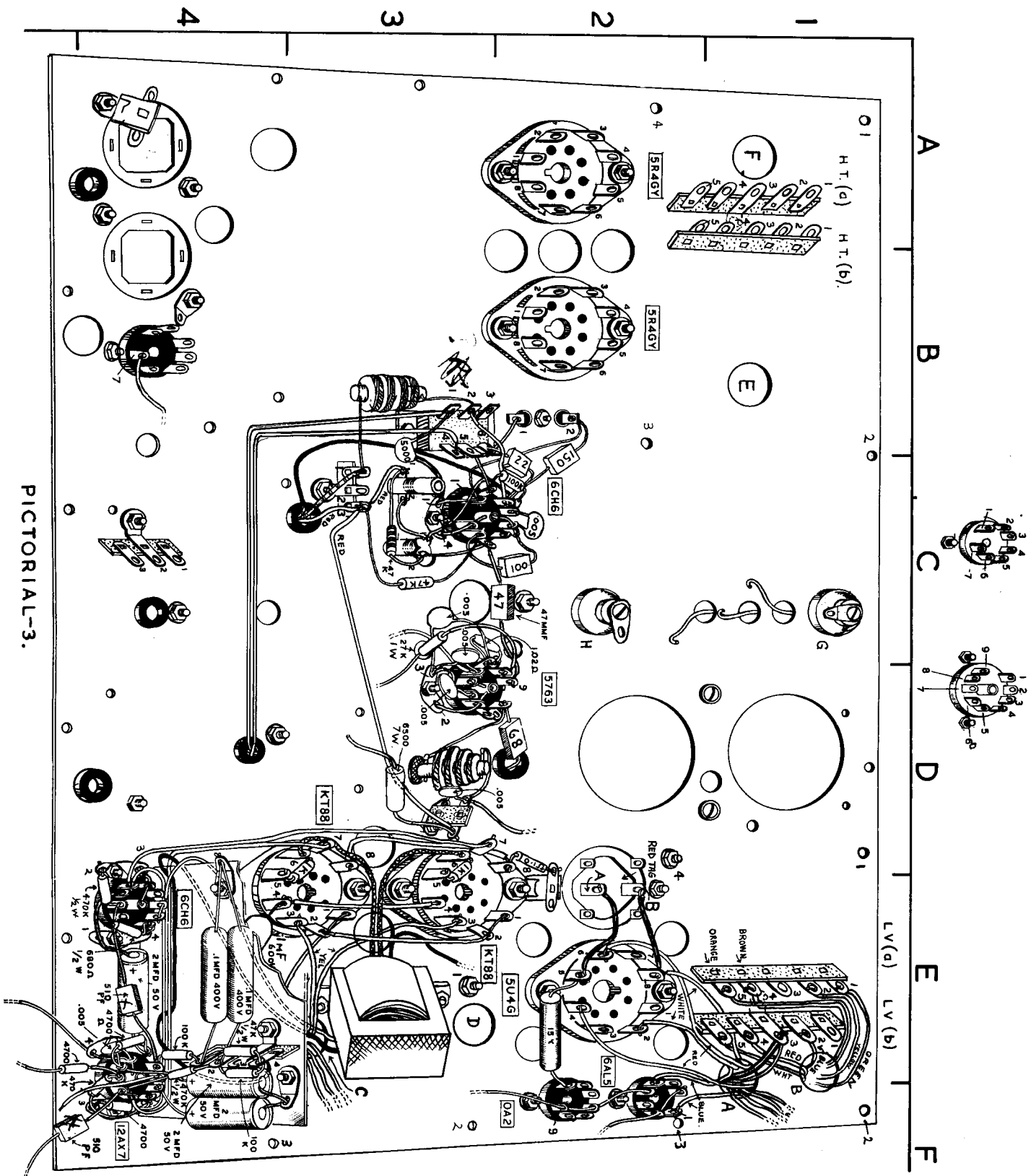

PICTORIAL-3.



Connect a BLACK wire from pin 4 of the 6CH6 valveholder (S) to pin 7 of the rear KT88 valveholder (NS).

Pass a thin bare wire through the nearest earth tag, pin 5 and the centre shield of the 6CH6 valveholder. Solder all three points.

Connect a BLACK wire between pins 1 (S) and 2 (NS) of the front KT88 valveholder and pins 1 (S) and 2 (S) of the rear KT88 valveholder. Reference E3.

Connect a BLACK wire between pin 2 of the front KT88 valveholder (S) and the solder tag mounted on the lip of the audio shield plate (NS).

CAUTION: This completes most of the speech amplifier and audio driver wiring. After the chassis top plate is mounted to the chassis base, this section will be nearly inaccessible. Consequently it is imperative that everything in the circuit is properly connected. All connections should be checked to make sure they are in the right place, that no shorts to earth or other leads occur and that components are in the proper place. Check that all connections are soldered. If possible check components in the wiring with an ohmmeter etc. See that by-pass electrolytics are correctly polarised.

On the driver transformer are two GREEN wires. Connect either GREEN wire to pin 6 of the front KT88 valveholder (NS) (reference E4).

Connect the other GREEN lead to pin 6 of the rear KT88 valveholder (NS) (reference E3).

On both KT88 valveholders connect a 1 K Ω resistor (BROWN, BLACK, RED) from pin 6 (S) to pin 5 (S).

Connect a BLUE wire from pin 8 of the front KT88 valveholder (S) to pin 8 (NS) of the rear KT88 valveholder.

Connect a .1 Ω meter shunt resistor from pin 8 of the rear KT88 valveholder (NS) to the adjacent 1-way tagstrip (NS).

Connect a BROWN wire from pin 4 of the front KT88 valveholder (NS) to pin 4 of the rear KT88 valveholder (NS).

OSCILLATOR STAGE WIRING

Run a short bare wire from pin 2 of the 6CH6 (NS) (reference C3) to tag 5 of the nearby crystal VFO switch (S).

Run a bare wire from tag 1 on the crystal socket (S) to tag 6 on the switch (NS).

Cut both leads of a 100 K Ω resistor (BROWN, BLACK, YELLOW) to $\frac{1}{2}$ ". Connect one lead to pin 2 (S) and the other lead to earth tag 2 on the 6CH6 valveholder (S) (reference C3).

Run a bare wire through earth tag 1 (NS), valveholder pin 1 (S) and crystal socket tag 2 (NS).

Connect a BLUE wire to tag 1 (NS) of the 3-way tagstrip mounted in front of the crystal oscillator slug tuned coils.

Run the wire as shown in Pictorial 3 through the 3/8" grommet (reference C4) to tag 2 of the 5-way tagstrip on top of the chassis (NS). See Pictorial 4.

Connect a short piece of GREEN wire from the valveholder pin 3 (NS) to the crystal switch tag 2 (NS).

With short leads, connect a 150 pF mica capacitor between crystal socket tag 2 (S) and valveholder pin 3 (NS).

With short leads, connect a 22 pF mica capacitor between valveholder pin 3 (S) and crystal switch tag 6 (S).

Connect a .005 μ F disc ceramic capacitor between crystal switch tag 1 (NS) and earth tag 1 (S) at the valveholder. Position close to, but clear of the chassis.

Connect a .001 μ F mica capacitor from the valveholder pin 8 (NS) to earth tag 3 (NS). Position capacitor close to the chassis and clear of the ventilation holes.

Run a bare wire from the valveholder centre shield (S) through tag 5 (NS) to earth tag 3 (S).

Connect one lead of a .005 μ F disc ceramic capacitor to pin 5 (S).

Connect the other lead to tag 4 (NS).

Connect a BLACK wire to pin 4 (S). Run the wire in the same manner as the BLUE wire through the grommet (reference C4) to tag 5 of the 5-way tagstrip on top of the chassis (NS).

See Pictorial 3 and connect a 47 K Ω resistor (YELLOW, VIOLET, ORANGE) between tag 2 (NS) of the smallest oscillator coil and tag 1 of the larger coil.

Connect a bare wire link between pin 7 (NS) of the 6CH6 valveholder and tag 2 of the smaller oscillator coil (S).

Run a bare wire through tag 1 of the smaller coil to tag 2 of the larger coil. Solder both connections and leave $3\frac{1}{2}$ " of wire extending past tag 1 of the smaller coil.

Connect a RED wire between the larger oscillator coil tag 1 (S) to tag 3 of the 3-way tagstrip (NS).

Connect a bare wire from centre shield (S) pin 9 (S) to earth tag 4 (S).

Connect a RED wire to tag 3 of the 3-way tagstrip (NS). Run the wire as shown, to the 1-way tagstrip adjacent to the driver RF choke (NS). See Pictorial 3.

Connect a .005 μ F disc ceramic capacitor from the 1-way tagstrip (NS) to the adjacent solder tag (S).

Connect a RED wire to tag 3 of the tagstrip near the oscillator coils (NS). Run the wire through the adjacent grommet to tag 1 of the 4-way tagstrip (NS) near the 5763 valveholder on top of the chassis. See Pictorial 4. Leave sufficient wire to clear the VFO switch which will be mounted later.

Connect a 47 K Ω 1 watt resistor (YELLOW, VIOLET, ORANGE) from tag 3 (S) of the 3-way tagstrip to the 6CH6 valveholder pin 8 (S).

Connect a 1.1 mH RF choke from tag 1 of the same tagstrip (S) to tag 2 of the crystal switch (S). Position this choke over and in line with the slide switch. It must clear the loading capacitor shaft.

Cut both leads of a 47 pF mica capacitor to $1\frac{1}{4}$ " length and slip 1" lengths of sleeving over each lead. Connect one lead to pin 7 of the 6CH6 valveholder (S).

Connect the other lead to pin 9 of the 5763 valveholder (S) (reference D3). Position the capacitor to clear the $\frac{3}{4}$ " hole between valveholders as shown in Pictorial 3.

DRIVER STAGE WIRING

Connect a 1.02 Ω meter shunt resistor from pin 7 of the 5763 valveholder (NS) (reference D3) to earth tag 4 (S). Position as shown.

Cut both leads of a .005 μ F disc ceramic capacitor to $3/8$ ". Connect one lead to pin 7 (NS) and the other lead to earth tag 3 (NS).

Cut both leads of a .005 μ F disc ceramic capacitor to $3/8$ " length. Connect one lead to earth tag 3 (NS) and the other lead to pin 6 (NS).

Strip both ends of an ORANGE wire $3\frac{1}{4}$ " long. Connect one end to pin 6 (S). Leave the other end free.

Cut both leads of a .005 μ F disc ceramic capacitor to $\frac{1}{2}$ " length. Connect one lead to earth tag 3 (S) and the other lead to pin 4 (NS).

Run a bare wire from pin 5 (S) to the valveholder centre shield (NS).

Run a bare wire from the valveholder centre shield through pin 3 to earth tag 2. Solder all three connections including the wire from pin 5 to the centre shield.

Connect a $1\frac{3}{4}$ " bare wire from the bottom tag of the $2\frac{1}{2}$ mH RF choke (S) (reference D3) to pin 1 (NS). Be sure this lead clears all other connections.



Cut one lead of a 68 pF mica capacitor to $\frac{1}{2}$ " length and connect to pin 1 (S). Run the other lead through the nearby $\frac{3}{8}$ " grommet.

Cover one lead of a 27 K Ω 1 watt resistor (RED, VIOLET, ORANGE) with a $\frac{3}{4}$ " length of sleeving as shown in Pictorial 3 and connect to pin 8 (S). Leave the other end free.

Connect a bare wire to the top tag of the 2 $\frac{1}{2}$ mH RF choke (S) and connect the other end to the adjacent 1-way tagstrip (NS). Be sure the lead touches nothing else.

Connect one end of a RED wire 3 $\frac{1}{2}$ " long to the same point (NS). Leave the other end free.

Cut one lead of a 6500 Ω 7 watt resistor to 1". Bend as shown and connect to the same point (S). Leave the other end free.

This completes most of the driver stage wiring.

NOTE: The low voltage supplies transformer and modulation transformer will be mounted at this time. They will form a base allowing the chassis top to be set on end. In this position most of the top components may be mounted without danger of damage to them during wiring. Cut all transformer leads to an appropriate length before making the indicated connections.

The transformers supplied are already fitted with mounting hardware. Before mounting, remove nuts and washers from transformer base plates.

See Pictorials 3 and 4 and mount the LV supplies transformer. Pass the transformer leads through holes A and B. Do not tighten the bolts through holes 1 and 2 as yet, they will be required for mounting the top plate to chassis later.

See Pictorials 3 and 4 and mount the modulation transformer. Pass the leads from the transformer through holes C and D. Only tighten the two inner mounting bolts securely.

Connect each of the YELLOW leads from the modulation transformer to pin 3 of each KT88 valveholder (S). The other leads will be connected later.

On the LV supplies transformer, separate the two WHITE leads and connect either one to pin 2 of the 5U4G valveholder (S) (reference F2).

Connect the other WHITE lead to pin 8 of the 5U4G valveholder (NS).

Separate the two RED leads and connect one lead to pin 4 of the 5U4G valveholder (S).

Connect the other RED lead to pin 6 of the 5U4G valveholder (S). Run this lead under the two WHITE leads.

Separate the two BLUE leads and connect either one to pin 1 of the 6AL5 (reference F2) (the rear 7-pin valveholder) (S).

Connect the other BLUE lead to pin 5 of the 6AL5 valveholder (S).

LV Supplies Primary Wiring.

Coming through hole B are the primary tapings of the transformer. These will be connected to the two adjacent 5-way tagstrips LVa and LVb (reference F1).

NOTE: When connecting, only strip the wire enough for one turn around the tag. Fix the wire to the tag and push to the bottom of the slot in the tag. Use a minimum of solder so as to leave a clear hole through the top of the tag for fixing mains connections at a later step.

Cut to length and connect the GREEN lead to LVa1 (S).

In like manner, connect the BLUE lead to LVb2 (S).

Connect the RED lead to LVb4 (S).

Connect the WHITE lead to LVb5 (S).

Connect the YELLOW lead to LVa2 (S).

Connect the BROWN lead to LVa4 (S).

Connect the ORANGE lead to LVa5 (S).

NOTE: It would be advisable at this stage to determine whether the mains supplies to be used are in the region 100-150 volts AC or 200-250 volts AC. Then connect as follows:-

For 100-150 volts AC Operation:

() Connect a short length of GREY wire from LVa1 (S) to LVa4 (S).

() Connect a short length of GREY wire from LVb2 (S) to LVa2 (S).

For 200-250 volts AC Operation:

Connect a short length of GREY wire between LVa4 (S) to LVa2 (S).

This now completes the primary wiring.

Select the heavy gauge BLACK wire and the YELLOW wire coming from hole A and connect as follows:-

Connect the YELLOW wire to LVb3 (NS).

Connect the BLACK wire to LVb3 (S).

Run a bare wire from pin 7 of the 6AL5 valveholder through pin 2 and allow $1\frac{1}{2}$ " to extend past pin 2. Be sure the wire will clear pin 1. Solder pin 7 and pin 2. Leave the end protruding past pin 2 free. Ensure that the wire clears the valveholder centre post.

Run a bare wire from pin 4 of the 6AL5 valveholder through pin 4 of the OA2 (reference F2) (front 7-pin valveholder) through pin 7 of the OA2. Leave $2\frac{3}{4}$ " of wire extending past pin 7 of the OA2 valveholder and solder all connections. Also ensure that the wire clears the valveholder centre post.

Connect a 15 K Ω 5 watt resistor from pin 1 of the OA2 valveholder (S) to pin 5 of the 5U4G valveholder (NS). Position as shown in Pictorial 3.

Mount a 40 + 40 μ F electrolytic capacitor to the capacitor mounting wafer next to the 5U4G valveholder. Insert the capacitor through the mounting plate with the RED tag positioned as shown. Twist the mounting prongs to secure it.

Connect a bare wire to pin 5 of the 5U4G valveholder (S). Slide a length of sleeving over the wire and connect to capacitor tag A (NS).

Connect a bare wire to pin 8 of the 5U4G (S). Slide a length of sleeving over the wire and connect to capacitor tag B (NS).

Connect a 4" length of GREEN wire to pin 7 of the 6AQ5 valveholder (S) (reference B5). Strip the other end and leave free for later connection.

PARTIAL WIRING OF THE FINAL AMPLIFIER

At the centre rear of the chassis are a group of $\frac{3}{8}$ " holes in a line (reference D1 and D2). Refer to Figure 8 and Pictorial 4. Mount two feedthrough insulators at holes H and G with the long cones above the chassis. The fibre washers supplied with the insulators are placed each side of the chassis between the metal and the insulators. On the top and bottom of each feedthrough insulator, mount solder tags in the positions shown with two on the top of the rear insulator.

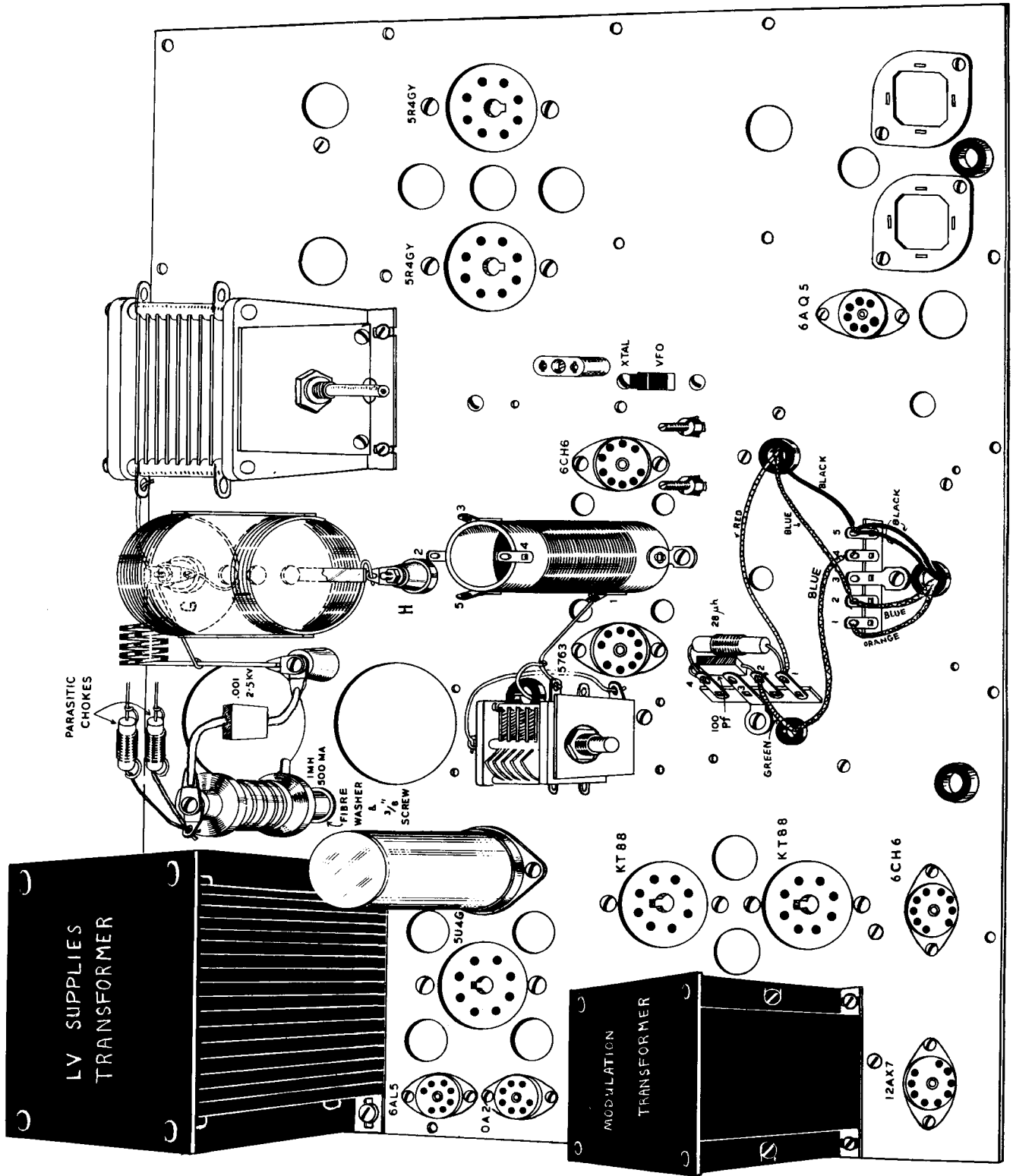

PICTORIAL-4.

Mount a standoff insulator on top of the plate in the place shown in Pictorial 4. Position two 4BA solder tags on top of the insulator. Use 4BA x $\frac{1}{4}$ " screws and a fibre washer between bottom of insulator and chassis.

In line with the standoff insulator and next to the power transformer, mount the 1 mH 500 mA RF choke using 4BA x $\frac{3}{8}$ " screw and 4BA fibre washer. Position tags as in Pictorial 4.

Mount the driver tank coil over the $\frac{3}{4}$ " hole at the chassis centre, using 4BA x $\frac{1}{4}$ " hardware. Position the coil tags as shown in Pictorial 4 and centre the coil over the hole before tightening.

Prepare the final tank coil for mounting as follows: Of the three taps protruding out from the side of the coil, cut the two outside ones to a length of 2.1/8" from the plastic coil support. Cut the centre lead to 1.7/8". Grasp about 1/8" of wire at the end of each lead with long nosed pliers and form an open hook by twisting the pliers sharply.

Mount the final amplifier anode coil by connecting the ends to the solder tags on top of the feedthrough insulators. Adjust the coil until the three taps are centred in the $\frac{3}{8}$ " chassis holes. Then solder the coil ends to the solder tags. Take care in soldering to prevent damage to the plastic coil form. On the underside of the chassis and at a distance of about $\frac{1}{4}$ " from the surface, bend the taps in the approximate positions as shown in Pictorial 3. This will make it easier later to make the switch connections.

Mount the 10 metre anode coil by bending the solder tag at the rear feedthrough insulator around the short end of the coil. Then bring the long end of the coil over to the straightened tag on the standoff insulator. Make sure this coil clears the large holes in the chassis and solder both connections.

Connect a .001 μ F 2500 volt mica capacitor from the remaining solder tag on the standoff insulator (S) to the tag on top of the RF choke (S). Bend the tags to place the capacitor as shown in Pictorial 4.

Cut one lead on each of the two parasitic chokes to $1\frac{1}{4}$ " length and connect these leads to the top tag of the RF choke (S). Leave the other ends free.

Mount the driver tuning capacitor to the mounting bracket next to the 5763 valveholder. Use a $\frac{3}{8}$ " lockwasher behind the bracket and a $\frac{3}{8}$ " nut in front with a flat washer.

Connect a heavy bare wire from the solder tag on the bracket (S) to the rotor tag of the capacitor (S).

Connect a heavy bare wire to driver coil tag 1 (S). Arrange this wire to clear the 5763 valveholder and connect to the rear driver capacitor stator tag (S).

Connect the 68 pF capacitor lead coming through the chassis at this point to the heavy wire (S).

On the 4-way tagstrip above chassis, connect a 100 pF mica capacitor from tag 2 (NS) to tag 4 (NS).

On the same tagstrip, connect a 28 μ H choke (BLACK spot) from tag 1 (S) to tag 4 (NS).

ASSEMBLY OF CHASSIS TOP-PLATE AND BASE

NOTE: Set the chassis top-plate upside down on the bench with the audio section toward the front right. The two transformers will support one side. A block of sufficient height or the high voltage transformer should be placed under the other side to allow the coils to clear the bench while working with the chassis.

The loose transformer leads can be temporarily inserted in the ventilation holes near the 5U4G valveholder to keep them out of the way. All other leads should be extended straight up to clear the chassis frame and the leads along the side of the KT88 valveholders must be run close to the valveholders.

During the assembly operation, it will be necessary to guide the chassis base onto the top carefully to prevent component damage and to make sure that none of the wires get squeezed between two sections. The holes around the perimeter of the chassis base should be placed toward the bottom side of the chassis top-plate. These holes are used to bolt the two sections together.

Remove the two fixing screws holding the outside edge of the LV supplies transformer.

Remove also the two outer screws of the modulation transformer.



As the chassis frame is lowered onto the top plate, guide the long cable wires at point 5 through the 3/8" grommet adjacent to the audio section.

Using nine 2BA x 3/8" screws, with lockwashers under the nuts, bolt the chassis top to the chassis base. The screws pass through the holes along the edge of the chassis base frame. All screws except screws 1 and 2 of the main HT transformer and screws 1 and 3 of the filter choke as shown in Figure 8 should be inserted before any are tightened. The four screws mentioned hold one side of the MAIN HT transformer and FILTER CHOKE and are omitted until these parts are mounted. However, these holes must be aligned before tightening the other side. The cable near the low voltage transformer may be moved to allow access to the nuts at that point.

Replace the modulation transformer nuts and washers.

Replace the LV supplies transformer nuts and washers. At the transformer mounting hole nearest to the chassis rear edge and centre, mount the fixing nut and washer above the chassis so as to clear the LV supplies filter choke which will be mounted there at a later step.

When all but the high voltage transformer and choke mounting screws are in place, tighten a few to maintain alignment. The entire unit can now be placed on its end with the transformers supporting it, while the rest of the screws are tightened.

WIRING IN THE MODULATOR-POWER SUPPLY COMPARTMENT

NOTE: Refer to Pictorial 5 for this portion of the wiring.

Cut both GREEN leads of the LV supplies transformer to length and strip back $\frac{1}{4}$ ". Connect either lead to tag 5 of tagstrip CC (S). Connect the other GREEN lead to tag 4 on CC (S). These are high voltage tags, so special care is required in wiring and soldering to provide maximum clearance between tags and between each tag and earth.

Cut the two remaining (BROWN) leads from the transformer to length and strip back $\frac{1}{4}$ ". Connect either lead to tag 2 on CC (S). Connect the other lead to tag 1 of CC (NS). Now recheck your work for the preceding steps to avoid any accidental shorts or earthing.

Cut a BLACK wire to 5.1/8" and strip both ends. Connect it from pin 3 of the 6AL5 valveholder (S) to tag 1 of tagstrip CC (S). Position as shown in Pictorial 5.

Loosely mount the fuseholder to the rear of the chassis at position FH and connect the GREY wire from the cable form to tag 2 on the fuseholder (S). Rotate fuseholder, and tighten in position as shown in Pictorial 5.

Connect a short piece of GREY wire between fuseholder tag 1 (S) and tagstrip BB tag 2 (S).

Mount the mains cable through grommet E. Trim the outer insulation back $1\frac{1}{2}$ " from the end of the cable and $\frac{1}{4}$ " of insulation from the ends of the RED, GREEN and BLACK inner wires. Twist and tin these wires. To prevent the cable being pulled back through the grommet, tightly wind on about 5" of insulation tape to the end of the outer insulation of the cable.

Connect the BLACK wire to tagstrip AA tag 3 (S).

Connect the GREEN wire to tagstrip AA tag 2 (S).

Connect the RED wire to tagstrip AA tag 1 (S).

Mount the LV supplies filter choke to the inside of the chassis base plate using the four 5/32" mounting holes on the base plate rear. Secure on the outside with 4BA nuts and lockwashers.

Connect either filter choke lead to the A tag of the filter capacitor, running the lead close to the chassis (NS). Connect the other choke lead to the B tag of the filter capacitor (S). Run this lead against the chassis.

Slip a 5/8" length of sleeving over the bare wire coming from pin 2 of the 6AL5 valveholder. Connect this lead to tag 3 of tagstrip DD (S).

Connect the bare wire coming from pin 7 of the OAZ valveholder to tag 2 of tagstrip EE (S). Position as shown to clear adjacent tags.

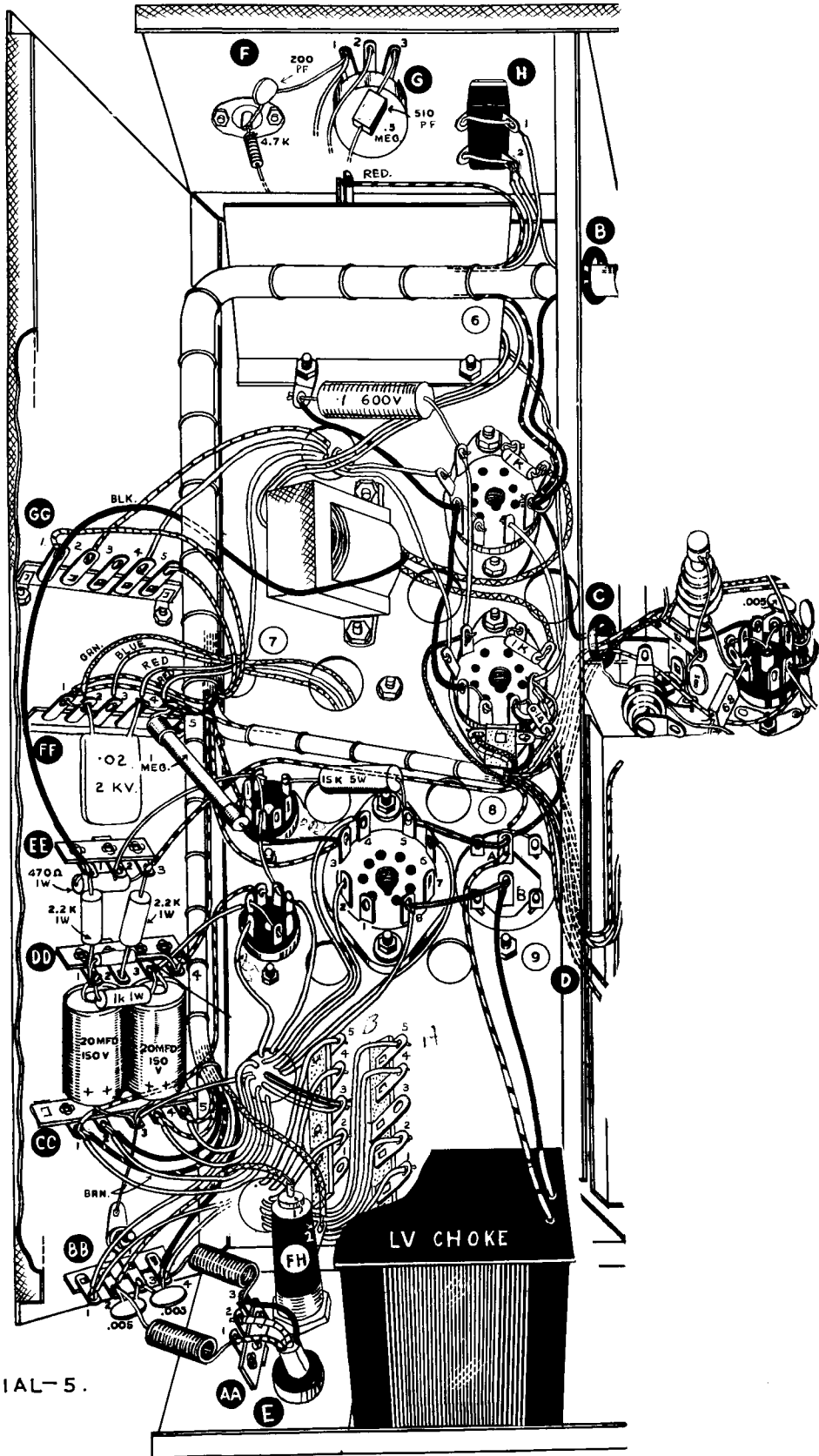

PICTORIAL-5.



Connect the ORANGE lead at point 7 of the cable to pin 5 of the OA2 valveholder (S).

Connect the RED lead at point 7 of the cable to pin 3 of the 5U4G valveholder (NS).

Cut the remaining driver transformer BLACK lead to length and connect to tag 1 on tagstrip EE (S).

Referring now to the RED lead of the modulation transformer coming through the hole nearest to the chassis front, connect to tag 5 of tagstrip FF, cutting to the appropriate length (NS). Connect a 1 megohm 2 watt precision resistor from tag 5 of FF (NS) to pin 3 of the 5U4G valveholder (S). Connect a strap from 5 to 4 of FF. Solder tag 5.

Connect the two BROWN leads to tagstrip GG, connect one to tag 2 (S) and the other to tag 4 (S). NOTE: For 7000 Ω A to A loading for the KT88's, these two BROWN leads should be exchanged with the YELLOW leads to the KT88 anodes. Normally the DX-100U is connected with the YELLOW leads to pin 3 of both KT88's for 5000 Ω A to A loading.

Connect the other RED wire coming from the other hole to tag 4 of FF after cutting to appropriate length (S).

Connect the BLUE lead to tag 3 of FF in the same manner (S).

Connect the GREEN lead to tag 2 of FF in the same manner (NS).

Connect the short strap lead from tag 2 (S) to tag 1 (S) of tagstrip FF.

CAUTION: High potentials are involved in the preceding connections. Inspect your work for accidental shorts or earthing.

The RED lead at point 6 of the cable may now be connected to the outside unsoldered tag on the audio shield plate tagstrip (S). Refer to Pictorial 5 for this connection.

Also at point 6 of the cable is a BLACK lead and a PINK lead. Connect both of these leads to pin 7 of the front KT88 valveholder (NS).

At point 8 of the cable, connect the BLACK lead to pin 7 of the rear KT88 valveholder (NS).

Connect two 8" BLACK wires in parallel by twisting them together along their lengths and at the stripped ends. This increases the current carrying capacity for the filaments of the 6146 valves. Connect one end of the pair to pin 7 of the rear KT88 valveholder (S) and pass the other end under the cable and through grommet D.

Cut and strip a 7" BLACK lead. Connect one end to pin 7 of the front KT88 valveholder (S) and pass the other end through grommet C to pin 4 of the 5763 valveholder (S) in the RF compartment. Position as shown in Pictorial 5.

AUDIO WIRING TO CHASSIS BASE

NOTE: Use sleeving where necessary.

Connect the free end of the 4700 Ω resistor to the microphone socket rear tag (NS).

Connect a 200 pF disc capacitor between the rear tag of the microphone socket (S) and tag 1 of the audio gain control (NS) as shown in Pictorial 5. Position the capacitor close to the microphone socket keeping the lead to the socket as short as possible.

Connect the bare wire already in the circuit to tag 1 of the audio gain control (S).

Connect the GREEN wire coming from the 12AX7 valveholder to tag 2 of the gain control (S).

Connect the free end of the 510 pF mica capacitor already mounted, to tag 3 of the gain control (S).

Now inspect wiring just completed. Look down between the audio shield and front of the chassis base and check position of components, re-position components where necessary.

Select a .1 μ F 600 volt capacitor and connect it between pin 4 of the front KT88 valveholder (S) and the solder tag mounted on the lip of the audio shield.

Connect the GREY lead at point 8 of the cable to pin 4 of the rear KT88 valveholder (S).

Still at point 8, connect the BLUE lead to pin 8 on the rear KT88 valveholder (S).

Connect the BROWN lead and the WHITE lead to the 1-way tagstrip at the rear KT88 valveholder (solder both tags).

Connect the RED lead to the A tag of the filter capacitor (NS).

Feed the RED lead from the tagstrip in the RF compartment through grommet C and connect to the A tag of the filter capacitor (S).

Whilst in the RF compartment, connect the YELLOW lead from point 8 of the cable to pin 7 of the 5763 valveholder (S). Run this lead clear of the 3/8" grommet and against the chassis.

Connect one end of a GREEN wire 10" long to tag 3 of tagstrip EE (S). Run this wire under the 1 megohm precision resistor along the cable and through grommet C. Leave the other end free.

WIRING IN THE HIGH VOLTAGE POWER SUPPLY COMPARTMENT

NOTE: Refer to Pictorial 6 for this portion of the wiring.

Mount the main HT transformer on top of the chassis next to the main tuning capacitor. Feed the two RED and one YELLOW leads through hole E. When correctly positioned, tighten all screws securely.

Mount the main HT filter choke on top of the chassis just behind the filter capacitor mounting wafers, tighten securely.

Mount the two 125 μ F filter capacitors with the tags positioned as shown in Pictorial 6. Secure by inserting the prongs in the slots in the wafer and twisting. NOTE: Prongs or capacitor case must not touch the chassis at any point.

Place the chassis on its rear apron and the transformers will hold it upright. The high voltage power supply compartment should now be on your right.

The bare wire coming from tag 2 of the double-pole single-throw switch should pass through the nearby earth tag to pin 3 on the 6AQ5 valveholder. Solder both connections.

Connect a BROWN wire from pin 2 of the 6AQ5 (S) to the Y-prong of the right-hand filter capacitor (NS).

NOTE: The cable may be pushed out of the way temporarily to permit full access to the valveholder.

At point 3 of the cable, connect the ORANGE lead through pin 5 to pin 6 of the 6AQ5 valveholder. Solder both connections.

The short BLACK lead at cable point 3 should be connected to pin 4 of the 6AQ5 valveholder (S).

Connect the two BROWN leads to the Y-prong of the right-hand filter capacitor as shown in Pictorial 6 (S).

NOTE: Here again, care should be exercised to prevent any accidental earthing of the capacitor case. The capacitor cases are at radically different potentials. An error in capacitor identification or associated wiring at this point will damage circuit components.

Connect a 2 $\frac{1}{2}$ " bare wire to the Z mounting prong of the same filter capacitor (S) as shown in Pictorial 6. Leave the other end free.

Near the corner of the chassis connect the two long BLACK leads of the cable form to the 1-way tagstrip and solder one side only.

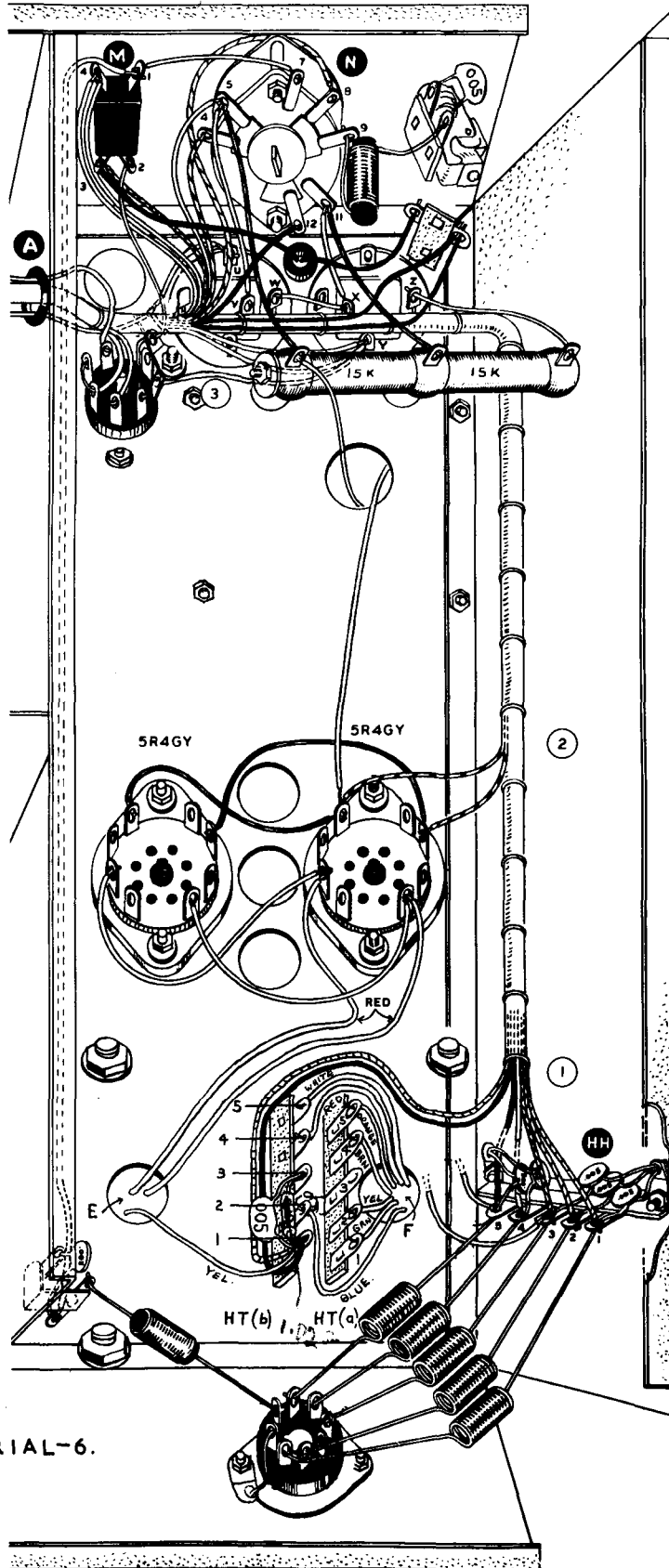

PICTORIAL-6.

Refer to the pictorial diagram for the position of the following wire. Start a bare wire through tag 11 of the phone-CW switch. Slip a $1\frac{1}{4}$ " length of sleeving over the wire, pass the wire through the X capacitor tag and then slip another $1\frac{1}{4}$ " length of sleeving over the wire. The end of the wire should then be connected to the W mounting prong of the filter capacitor on the left. Leave 3" of bare wire sticking out from tag 11 of the switch. Solder all three connections.

Connect a 6" RED lead from the U-prong on the left-hand filter capacitor (S) (see Pictorial 6) through grommet A and leave the other end free.

Pass a bare wire through switch tag 5 of the phone-CW switch and slip a $1\frac{3}{4}$ " length of sleeving over the end as it comes through. Connect the end to the V tag of the left-hand filter capacitor. See Pictorial 6 for this connection. Solder both tags and leave 3" of wire extending from switch tag 5.

Mount the 50 watt 30 K Ω centre-tapped bleeder resistor to the side chassis apron as shown in Pictorial 6. Use the screw supplied with the resistor for fixing.

The bare wire from the Z-prong right-hand capacitor should now be connected to the extreme right-hand tag of the bleeder resistor (S).

Slip a $2\frac{3}{4}$ " length of sleeving over the bare wire coming from switch tag 11 and connect to the centre bleeder resistor tag (S).

Slip a $1.3/8$ " length of sleeving over the bare wire from switch tag 5 and connect to the left bleeder tag (NS).

Cut either lead of the filter choke to the proper length and connect to the left-hand bleeder tag (S). Allow sufficient slack in the lead to enable it to be dressed clear of the resistor body.

There is a short RED lead and a long RED lead at point 2 of the cable. Connect the short lead to pin 2 of the right-hand 5R4GY valveholder (NS) and the long lead to pin 8 of the same valveholder (NS).

Connect a bare wire to pin 2 of this same valveholder (S) and slip a 3" length of sleeving over the wire. Connect the other end to pin 2 of the left-hand 5R4GY valveholder (S).

Connect a bare wire to pin 8 of the left-hand 5R4GY valveholder (S) and run it through a $2\frac{3}{4}$ " length of sleeving to pin 8 of the right-hand 5R4GY valveholder (NS).

Cut the remaining choke coil lead to an appropriate length and connect to pin 8 of the right-hand 5R4GY valveholder (S).

Referring now to the main HT transformer and the hole that has two RED and YELLOW leads coming from it, cut either RED lead to an appropriate length to reach pin 4 of the right-hand 5R4GY valveholder (NS). NOTE: Save the remaining piece of transformer lead and use it to connect this tag to pin 4 of the left-hand 5R4GY valveholder. Solder both tags.

Cut the other RED transformer lead to the proper length to reach pin 6 of the right-hand 5R4GY valveholder (NS). NOTE: Use the remaining piece of wire to connect this tag to pin 6 of the left-hand 5R4GY valveholder. Solder both tags.

Connect one end of a 4" piece of GREY wire to tag 5 of tagstrip HH (S).

Connect one end of another 4" piece of GREY wire to tag 3 of tagstrip HH (S).

Main HT Primary Wiring.

Coming through hole F are the primary tapings of the transformer. These will be connected to the two adjacent 5-way tagstrips HTa and HTb.

NOTE: When connecting, only strip the wire enough for one turn around the tag. Fix the wire to the tag and push to the bottom of the slot in the tag. Use a minimum of solder so as to leave a clear hole through the top of the tag for fixing mains connections at a later step.

Cut to length and connect the GREEN lead to HTa1 (S).

In like manner, connect the BLUE lead to HTb2 (S).



Connect the RED lead to HTb4 (S).

Connect the WHITE lead to HTb5 (S).

Connect the YELLOW lead to HTa2 (S).

Connect the BROWN lead to HTa4 (S).

Connect the ORANGE lead to HTa5 (S).

NOTE: It would be advisable at this stage to determine whether the mains supplies to be used are in the region 100-150 volts AC or 200-250 volts AC. Then connect as follows:-

For 100-150 volts AC operation:

() Connect a short length of GREY wire from HTa1 (S) to HTa4 (S).

() Connect a short length of GREY wire from HTb2 (S) to HTa2 (S).

For 200-250 volts AC operation:

Connect a short length of GREY wire between HTa4 (S) and HTa2 (S).

This now completes the primary wiring.

Connect the BROWN and GREY leads of the cable form to tag 1 of tagstrip HTb1 (NS).

Connect the YELLOW wire from the transformer to HTb1 (NS).

Connect a .1Ω meter shunt between HTb1 (NS) and HTb3 (NS).

Connect a .005 μF disc capacitor between HTb1 (S) and HTb3 (S).

At this point, a careful visual inspection is in order. This compartment contains wiring of the high voltage power supply and the mains voltage. Make doubly sure that there are no shorts or earths and the components such as the line filter chokes do not touch one another. Damage to expensive circuit components can result if care is not exercised in wiring and positioning parts.

This completes most of the wiring in the high voltage compartment.

ASSEMBLY AND WIRING OF 6146 SUB-CHASSIS

Identify the 6146 sub-chassis shown in Figure 10.

Mount two ceramic octal valveholders inside the sub-chassis, with their keyways facing outwards. Use 4BA x $\frac{1}{4}$ " screws and nuts. Mount two solder tags under each fixing nut.

Mount a ceramic feed-through insulator to the sub-chassis with the short cone and screw head on the inside of the sub-chassis. Mount one solder tag under the fixing screw as shown in Figure 10.

Mount a 3-way tagstrip in the hole to the left of valveholder A. NOTE: In each valveholder pin are two holes. When connecting the small capacitors use the holes nearest to the ceramic portion of the valveholder. Cut the leads just long enough to make the indicated connections.

Connect a .005 μF disc ceramic capacitor from pin 6 (NS) to pin 7 (NS) of valveholder A.

Connect a .005 μF disc ceramic capacitor from pin 1 (NS) to pin 2 (NS) of valveholder B. Position the capacitor to clear the adjacent earth tag.

Connect a 1000 pF disc ceramic capacitor from pin 2 (NS) to pin 3 (NS) of valveholder A.

Connect a 1000 pF disc ceramic capacitor from pin 3 (NS) to pin 4 (NS) of valveholder B.

Connect a .005 μF disc ceramic capacitor from tag 1 (NS) to tag 2 (NS) of the 3-way tagstrip.

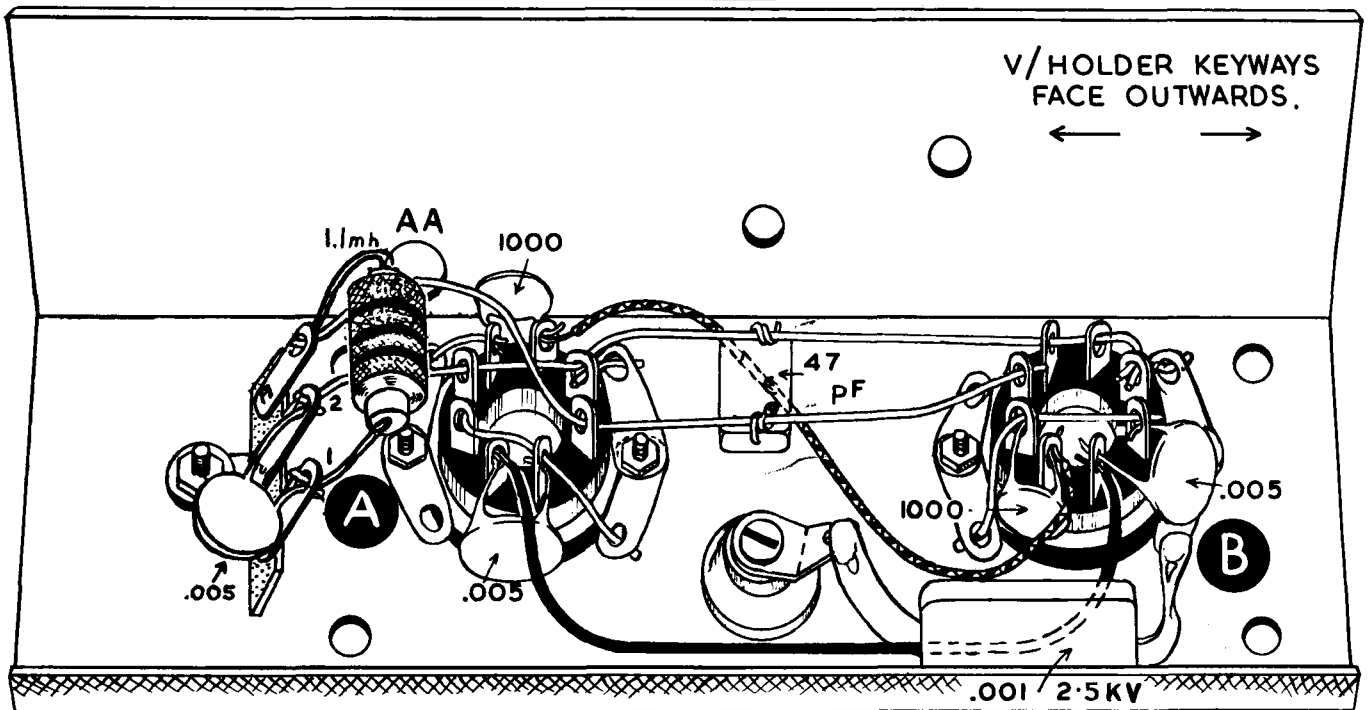

FIGURE-10.

Connect an **ORANGE** lead from pin 3 of valveholder A (NS) to pin 3 of valveholder B (NS). Run the lead close to the chassis.

Connect a **BLACK** lead from pin 7 of valveholder A (NS) to pin 2 of valveholder B (S). Run this lead close to the chassis also.

Run a heavy bare wire through the following tags in order (see Figure 10): tag 2 of the tagstrip, pins 1 and 4 of valveholder A and pins 6, 7, and 8 of valveholder B. Solder earth tag 2 of the tagstrip and pins 6 and 7 of valveholder B. **NOTE:** Bending valveholder tags facilitates insertion of wire.

Connect a heavy gauge bare wire from pin 8 of valveholder B (S) to the adjacent earth tag (S).

Run a heavy gauge bare wire through pins 1, 4 and the earth tag adjacent to pin 4 on valveholder B. Solder all three connections.

Connect a heavy gauge bare wire from pin 4 (S) to the adjacent earth tag (S) on valveholder A.

Connect a heavy gauge bare wire from pin 2 (S) to the adjacent earth tag (S) on valveholder A.

Run a heavy gauge bare wire through pin 8, pin 6 and the earth tag near pin 6 on valveholder A. Solder all three connections.

Run a heavy gauge bare wire through tag 3 of tagstrip, pin 5 of valveholder A and pin 5 of valveholder B. Bend the wire upward to clear the other bare wire between the terminal strip and valveholder A. Solder pin 5 on both valveholders.

Connect a .001 μ F 2500 volt capacitor from earth tag 4 on valveholder B (S) to the solder tag on the feed through insulator (S). Bend the capacitor tag around this tag and when soldering do not fill in the hole on the insulator solder tag, as a wire connects to that point at a later step.

Refer to Figure 10 and connect a 47 pF mica capacitor between the two heavy wires as shown. Keep the leads short and solder both connections.

On the tagstrip, connect a 1.1 mH RF choke from tag 1 (NS) to tag 3 (NS). Position as shown in Figure 10.

Set this sub-assembly aside temporarily.

WIRING IN THE RF COMPARTMENT

NOTE: Refer to Pictorial 7 for this portion of the wiring.

Position the chassis upside down on its transformer tops. The RF compartment is in the centre with the chassis in this position.

At point 4 of the cable, push the two **BLACK** leads, the **BLUE** lead and the **ORANGE** lead through the adjacent grommet. This will leave a **BROWN**, **GREEN** and a **VIOLET** lead remaining.

Mount the 500 K Ω (insulated shaft with slot) potentiometer in the hole adjacent to the 3-way tagstrip in the upper right-hand corner of this compartment. See Pictorial 7 for the position of the potentiometer tags.

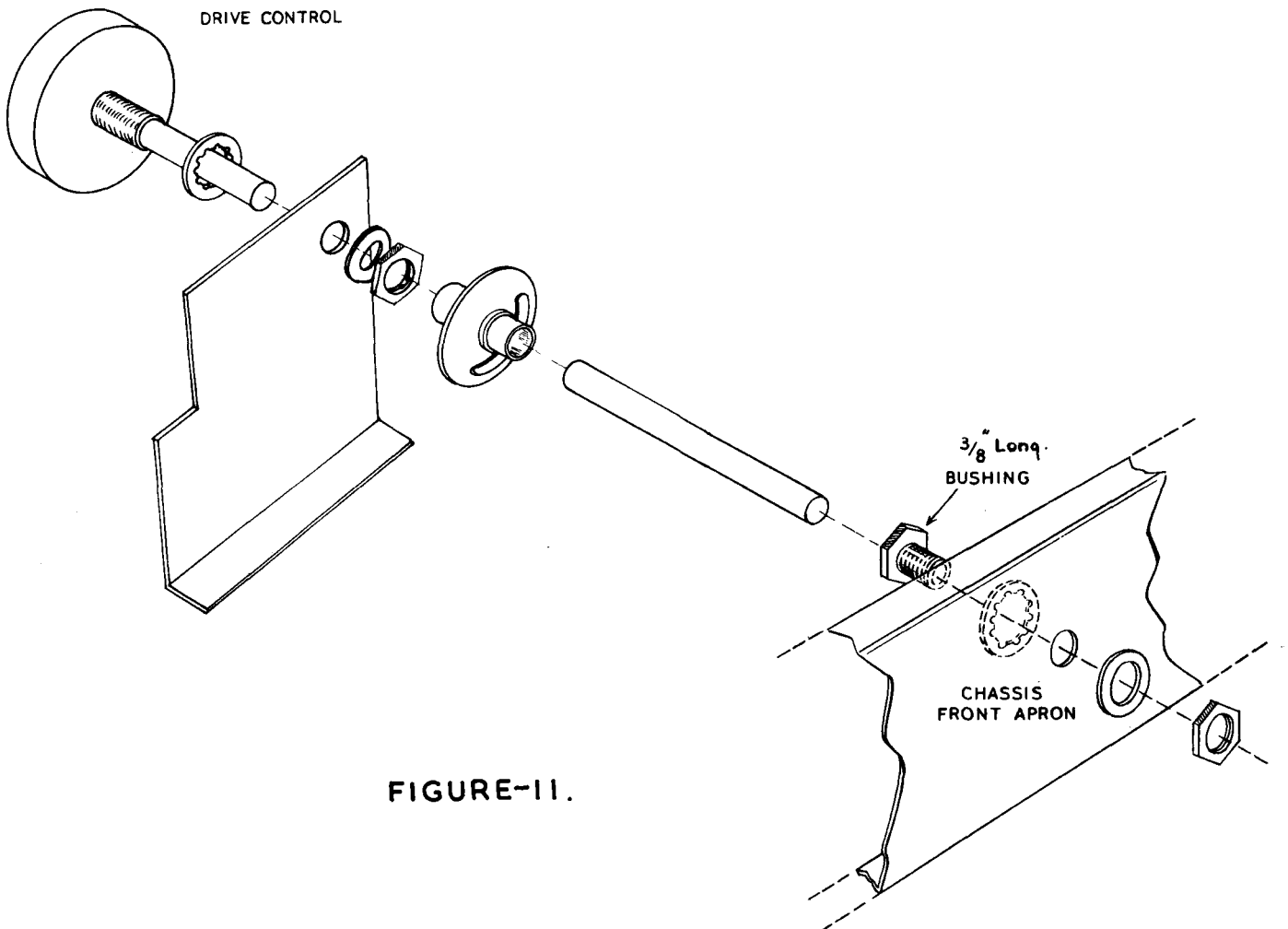
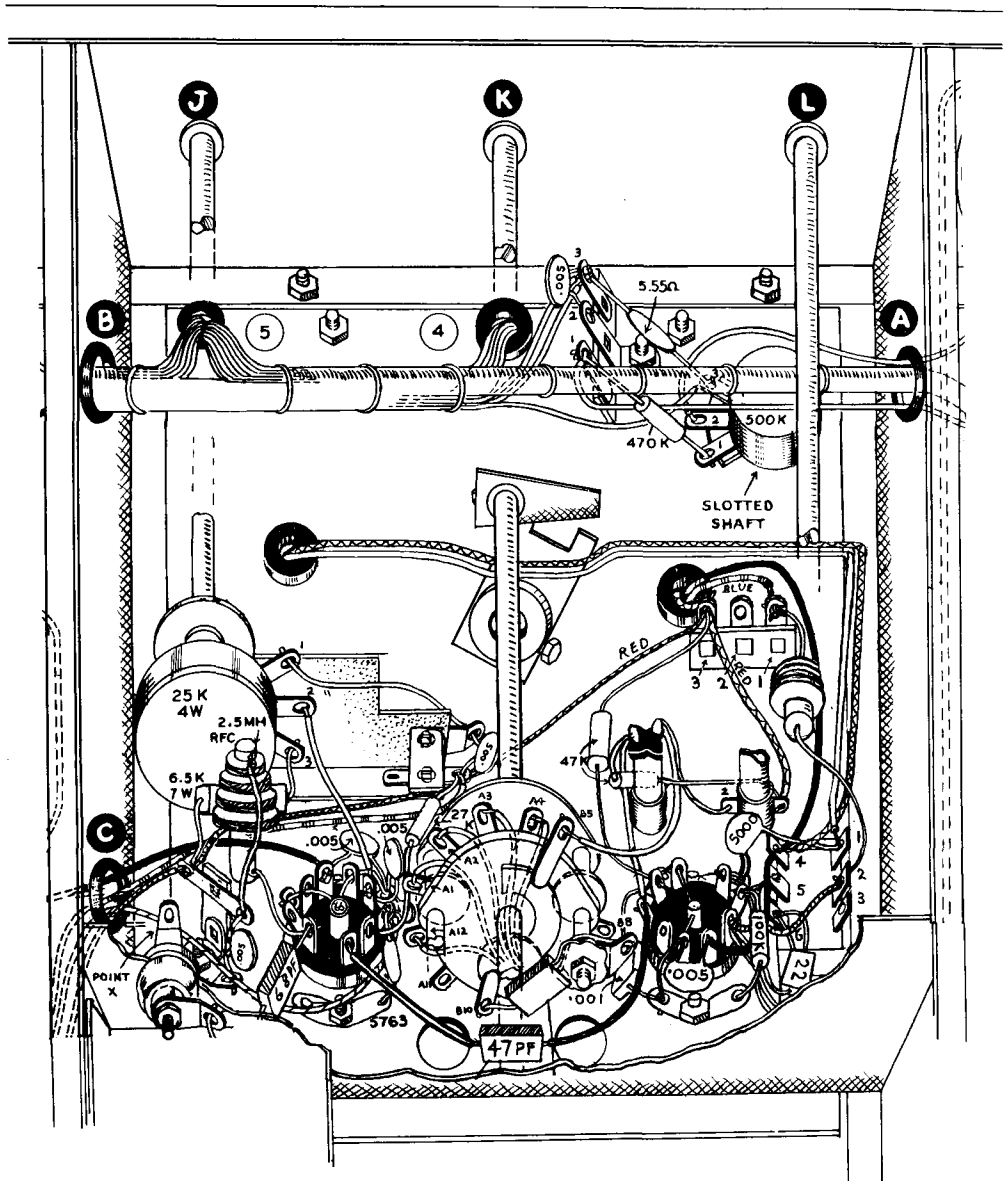

FIGURE-11.

Connect a **BLUE** wire 13" long to tag 1 on the Crystal-VFO switch located next to the crystal socket (S). Run the free end through the grommet in the middle left-hand side of this compartment.

Strip both ends of a 11 $\frac{1}{2}$ " **GREEN** wire and connect one end to tag 4 on the Crystal-VFO switch (S). Run the free end through the same grommet. Arrange wires as shown.



PICTORIAL-7.

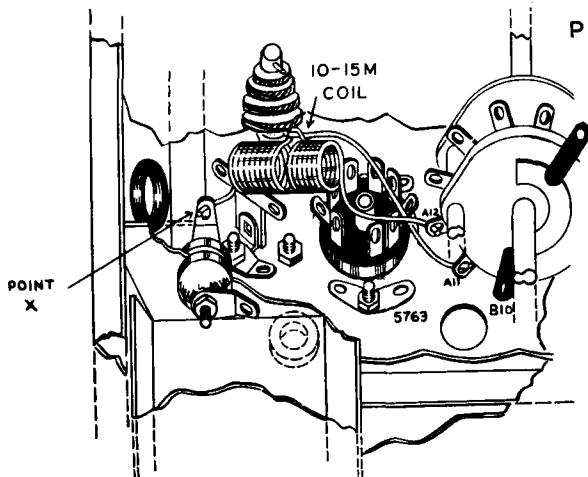

Refer to Figure 12 and mount the driver potentiometer, solder tag and 1-way tagstrip on the potentiometer mounting plate as shown. Use 4BA x $\frac{1}{4}$ " hardware.

Loosely install this assembly just in front of the 2.5 mH RF choke using 4BA x $\frac{1}{4}$ " hardware as shown in Pictorial 7. Refer to Figure 11 and fit the flexible coupler to the potentiometer shaft. Mount a $\frac{3}{8}$ " long brass bush in the appropriate front apron hole and pass the 4. $\frac{7}{8}$ " long extension shaft through the bush and into the coupler. Tighten the coupler grub screws and after aligning, tighten the panel mounting screws. Take care not to damage the RF choke.

Again refer to Pictorial 7 and connect the free end of the 6.5 K Ω 7 watt resistor to tag 3 of the driver potentiometer (S). Position leads as shown.

Connect the free end of the ORANGE wire coming from pin 6 of the 5763 valveholder to tag 2 of the drive control potentiometer (S).

Connect a bare wire between the earth tag at the base of the potentiometer mounting plate and tag 1 of the potentiometer. Solder tag 1 only.

Connect a .005 μ F disc ceramic capacitor from this same solder tag (S) to the adjacent 1-way tagstrip (NS).

Connect the free ends of the GREEN wire from grommet C and the 27 K Ω resistor from pin 8 of the 5763 valveholder to the 1-way tagstrip (S).

Refer now to the 500 K Ω pre-set potentiometer and the adjacent tagstrip in the upper right-hand corner. The VIOLET wire coming out of the cable at point 4 should connect to tag 3 of the potentiometer (NS).

Connect a 5.55 Ω shunt resistor from tag 3 of the potentiometer (S) to tag 3 of the tagstrip (NS). Arrange this resistor to clear the small hole in the chassis.

Connect a .005 μ F disc ceramic capacitor from tag 2 of the tagstrip (S) to tag 3 of the tagstrip (NS).

Connect the BROWN and GREEN wires at point 4 of the cable to tag 3 of the tagstrip (S).

Connect a 470 K Ω resistor (YELLOW, VIOLET, YELLOW) from tag 1 of the tagstrip (NS) to tag 1 on the potentiometer (S).

Connect the RED wire coming through grommet A to tag 1 on the tagstrip (S).

Connect the GREEN wire already connected to pin 7 of the 6AQ5 valveholder to the pre-set potentiometer tag 2 (S).

Now place the chassis upright and locate the tagstrips near the front of the chassis. See Pictorial 4.

Connect the two BLACK wires coming through the $\frac{3}{8}$ " grommet near the chassis front to tag 5 of the adjacent tagstrip (NS).

Connect the BLUE wire coming through this grommet to tag 2 of this tagstrip (S).

Connect the ORANGE wire coming through the same grommet to tag 1 of this tagstrip (NS).

Referring to the wires coming through the $\frac{3}{8}$ " grommet adjacent to the 4-way tagstrip, connect the BLUE wire across to tag 4 of the 5-way tagstrip (NS). Shorten the wire if necessary to make a direct connection.

Connect the GREEN wire to tag 2 of the 4-way tagstrip immediately adjacent to the $\frac{3}{8}$ " grommet (S).

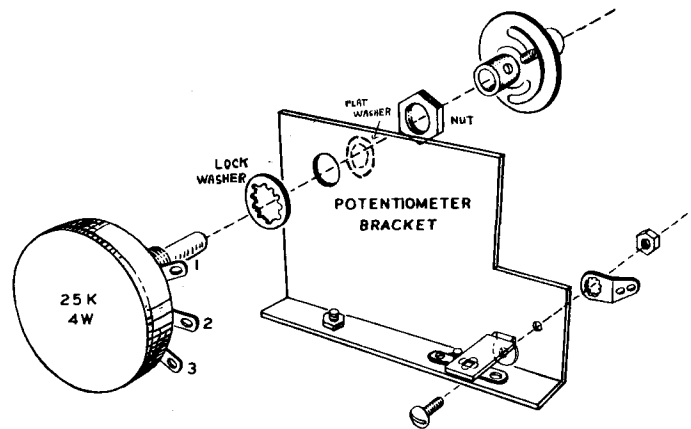

FIGURE -12.

Select the previously assembled VFO sub-assembly and place a 3/8" lockwasher over the switch bushing. Mount this sub-assembly from the top of the chassis with the two eyebolts through the two holes near the front of the chassis and the switch shaft through the 3/8" hole near front centre. Use 4BA nuts and lockwashers and a 3/8" nut and flat washer to secure assembly. After the VFO has been installed it will no longer be possible to stand the DX-100U upside down on its transformer tops as damage will occur to the plastic VFO dial assembly.

Connect the RED wire from the VFO sub-assembly to tag 4 of the 4-way tagstrip (S).

Connect the ORANGE wire from the VFO sub-assembly to tag 1 of the 5-way tagstrip (S).

Bring the remaining BLACK and BLUE wires around on the other side of the switch shaft and connect the BLUE wire to tag 4 of the 5-way tagstrip (S) and the BLACK wire to tag 5 of the same tagstrip (S). Arrange the wires neatly to clear the switch. Check all work in this section against the step-by-step instructions.

Mount three eyebolts on the bottom outside of the VFO shield cover using 6BA x 1/4" hardware. Then slip the cover over the VFO assembly with the eyebolts inserted in the three chassis holes. Use 4BA hardware on the eyebolt screws and small sheet metal screws to fasten the shield to the VFO sub-chassis.

Select the driver shield and mount a feedthrough insulator in the end hole as shown in Figures 13 A & B. Use a solder tag on each end of the insulator, pointing in the direction shown in Pictorial 7. Cut off the end of the screw protruding past the nut.

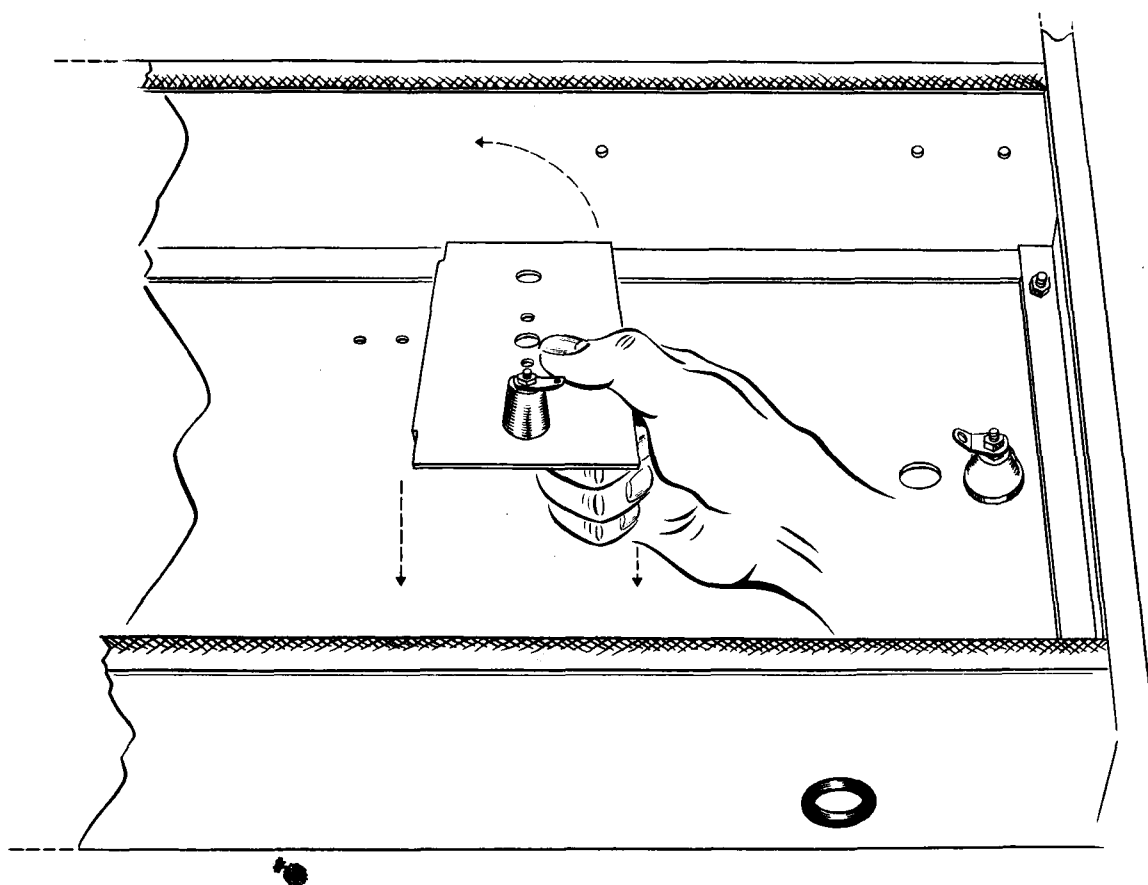

FIGURE -13A.

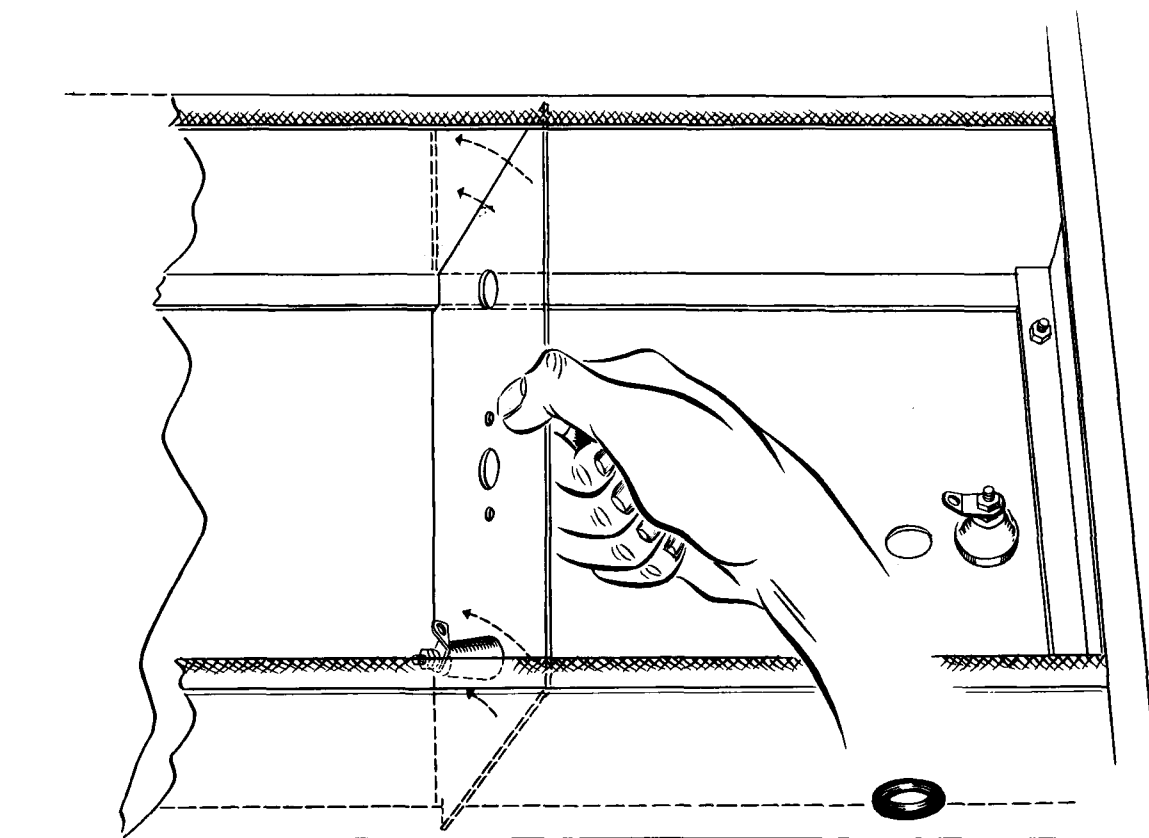

FIGURE-13B.

Turn the chassis on its back apron again and install this shield across the middle of the RF compartment with 4BA x $\frac{1}{4}$ " hardware. Refer to Pictorial 8 for location of the shield and to Figure 13A and B for method of installation. Note how the shield must be moved into position in two steps so as to pass the chassis flanges. When in correct position, tighten the fixing nuts.

Mount the large final amplifier shield plate with eyebolts as shown in Pictorial 9, using 6BA x $\frac{1}{4}$ " hardware to mount the eyebolts. Note that the eyebolts are on the back side of the shield. Tighten securely. Do not over tighten as this will cause the eyebolts to shear off.

Connect a 2" length of heavy gauge bare wire to the final anode tuning capacitor front end rotor tag (S).

Mount the final anode tuning capacitor as follows:- At the rear of chassis there is a group of four holes. In the two holes nearest the final amplifier shield, loosely install two 4BA x $\frac{3}{8}$ " screws. Beneath the chassis under the nut nearest the centre line insert two 4BA solder tags. Use a lockwasher underneath the other nut.

Then slide the final anode capacitor front mounting bracket underneath the screwheads and ensure that the $\frac{3}{4}$ " spindle goes through the shield cutout. Pass the heavy gauge earth wire attached to the capacitor down through the hole in the chassis. Position the two solder tags as shown in Pictorial 8 and tighten the fixing screws.

Bolt the rear mounting bracket to the chassis using 4BA x $\frac{3}{8}$ " hardware.

Underneath the chassis connect the bare wire from the front end of the final anode tuning capacitor to the solder tag nearest to the hole through which this wire protrudes (S).

Using 4BA x $\frac{1}{4}$ " hardware, mount four $\frac{3}{4}$ " long metal pillars, tapped 4BA, to the 4 holes on the topside of the 6146 sub-chassis, with screws and lockwashers placed on the chassis underside. Tighten securely.

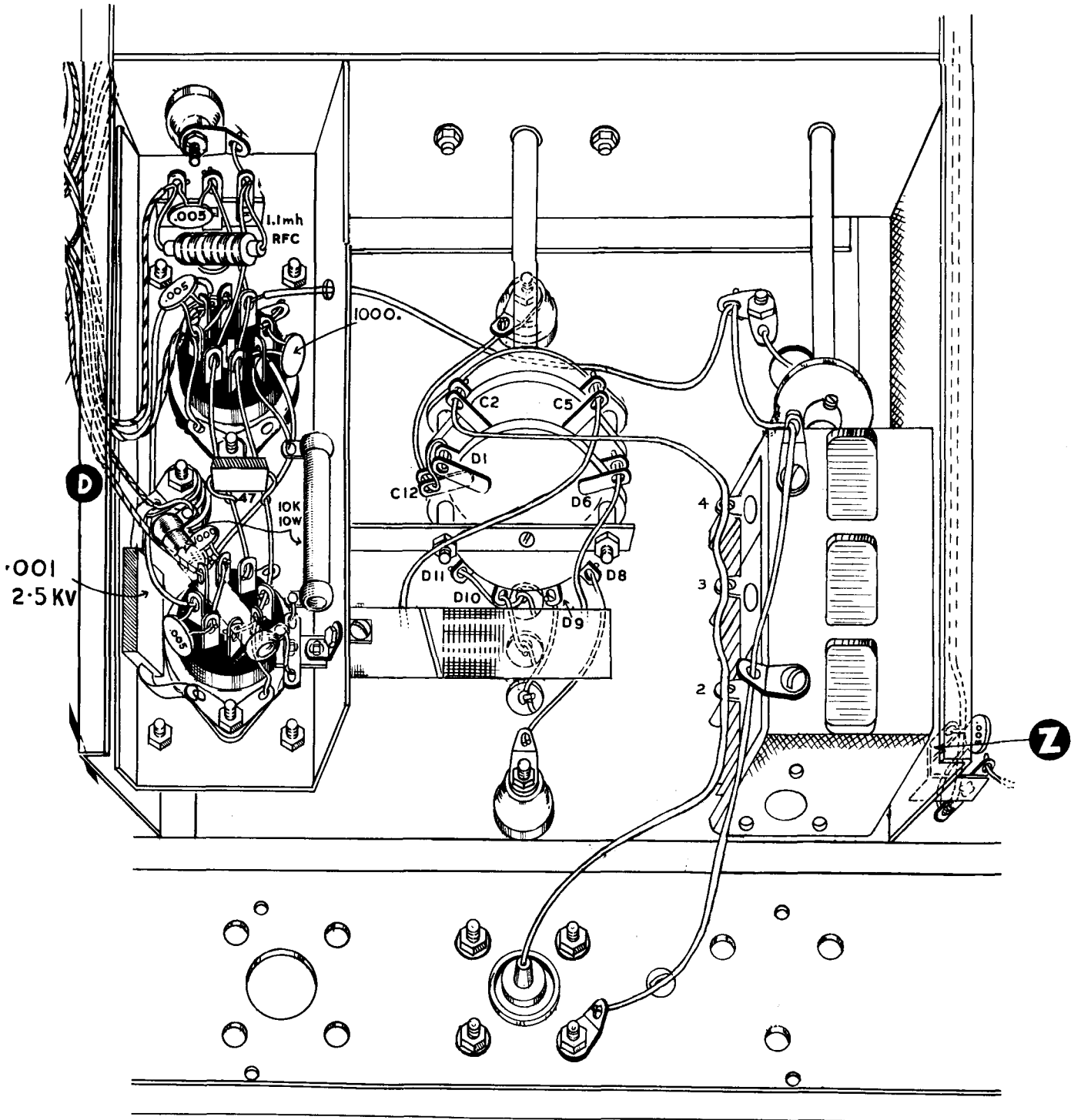

PICTORIAL-8.

Mount the 6146 sub-chassis in position and secure with four 4BA x $\frac{1}{4}$ " screws and lockwashers. See Pictorial 8. Check the feedthrough insulator on the 6146 sub-chassis from the chassis top plate. The stud bolt of the insulator should project at least $\frac{1}{4}$ " above the chassis and clear the chassis hole at all points. If not, correct this condition at this time.

When the above conditions are fulfilled, mount a 4BA solder tag at the stud end using two 4BA nuts. Bend the solder tag to make contact with the bottom RF choke tag and solder. If it will not reach the choke, lengthen with a short piece of bare wire.

Stand the transmitter on its rear apron and connects as follows.

At point 9 of the cable (within the 6146 compartment) connect the RED lead to the solder tag on the feed-through insulator (NS). See Pictorial 8.

Connect the ORANGE lead at this point to pin 3 of valveholder B (S). Refer to Figure 10 for valveholder identification.

Connect the twisted pair of BLACK wires coming through $\frac{3}{4}$ " grommet D to pin 7 of valveholder A (S).

Connect the VIOLET lead coming through grommet D to tag 1 of the tagstrip (S).

Connect a short bare wire from tag 3 of the tagstrip (S) to the adjacent solder tag on the feed-through insulator (S).

Using a 5" length of heavy bare wire, slip a 4" length of $2\frac{1}{2}$ " m. m. sleeving over the wire and pass it through hole AA in the side of the 6146 sub-chassis (see Figure 10). Connect the end of the wire to pin 1 of valveholder A (S) and connect the other end to one solder tag at the tuning capacitor mounting screw (NS). Run the wire down close against the chassis by bending it at right angles where it comes through hole AA.

The bandswitch consists of two main sections. The front section has one wafer and the back section has two wafers. Select the back section and refer to Figure 14 and Pictorial 8 to identify the tags.

Use a tapered instrument such as the tang of a small file to spread the holes in the switch tags so that large tinned wire can be inserted through them. Note that all tags are doubled to handle the extra current and therefore each pair should be treated as a single tag when making connections. The wire should be soldered to both tags when instructions for soldering are given.

Insert a large bare wire through both contacts of tag 12C and bring the end over to 1D. Arrange the wire to clear the switch post and shape the wire with pliers so as not to put undue strain on the switch tag. Solder both pairs of tags and leave $1\frac{3}{4}$ " of wire extending from tag 12C. Form the wire as shown in Figure 14.

Still using heavy gauge wire, solder the end of a 1" length to tag 11D. Leave the other end free.

Solder the end of a $1\frac{3}{4}$ " length of heavy gauge bare wire to tag 10D and leave the other end free.

Solder the end of a $2\frac{1}{4}$ " length of heavy gauge wire to tag 9D. Leave the other end free.

Solder the end of a $3\frac{1}{4}$ " length of heavy gauge bare wire to tag 8D. Leave the other end free.

Position the switch rotors as shown in Figure 14. Note the position of the rotor blades. Rotate both switches fully clockwise as viewed from the front so that this section of the switch will be properly oriented with respect to the front section to be installed later.

Remove the second set of nuts and lockwashers from the rear of the switch. Now mount the L shaped bracket as shown in Figure 14 using the nuts and lockwashers just removed.

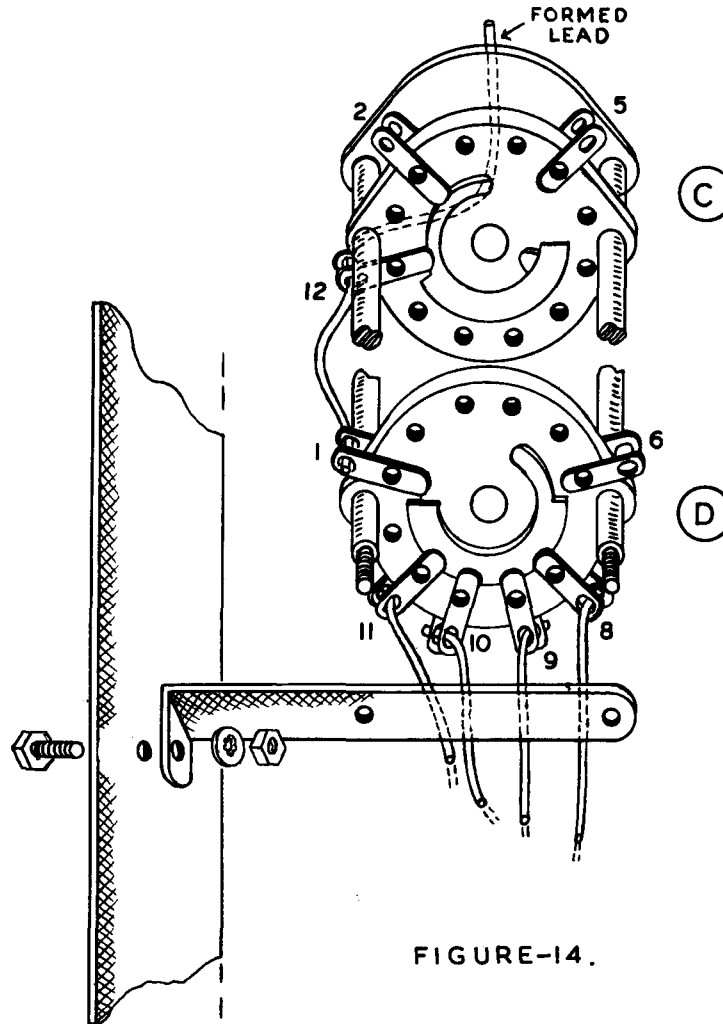

FIGURE-14.

Move the entire switch into position as shown in Figure 14, taking care to guide the single heavy gauge wire protruding from the front of the switch into the solder tag on the feedthrough insulator near the driver shield plate. See Pictorial 8. Use 4BA x 3/8" hexagonal head screw to fasten the switch mounting foot to the hole near the centre on the side of the 6146 sub-chassis. Do not tighten the mounting screw on the foot at this time.

Solder the bare wire to the feedthrough insulator solder tag.

Refer now to Pictorial 8.

Bend the bottom tank coil tap protruding through the chassis approximately $\frac{1}{2}$ " to the right, keeping it centred in the chassis hole and connect the heavy wire from tag 9D to it (NS).

Leave the centre coil tap straight out from the chassis and connect the wire from tag 10D to it (NS).

Bend the top coil tap approximately $\frac{1}{2}$ " to the left, keeping it centred in the chassis hole and connect the wire from switch tag 11D to it (NS). These connections will not be soldered until after the switch mounting foot has been tightened.

The long wire from tag 8D should be run clear of the other taps and connected to the rear feedthrough insulator solder tag (NS).

Use a pair of pliers to set the VFO switch (the short shaft protruding through the bottom of the chassis) to its fully clockwise position.

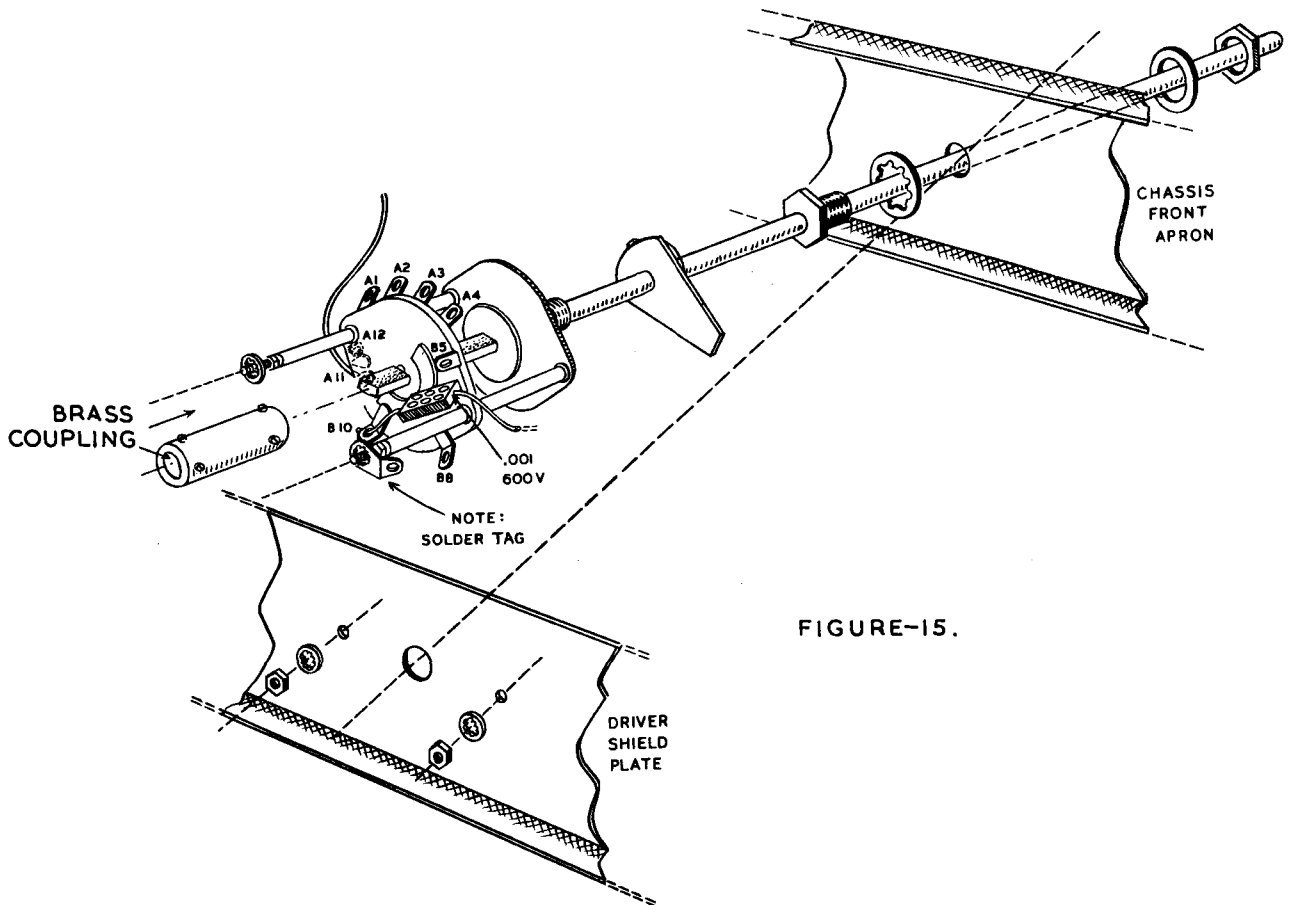

FIGURE-15.

Select the VFO switch drive plate (see Figure 16). Insert a 4BA x 3/8" hex head screw into the brass hub. Mount the drive plate to the switch with the raised hub uppermost, tighten up temporarily at position illustrated in Figure 16A. Check that switch rotation is equal either side of the chassis centre line. Position BLUE and GREEN wires as shown in Pictorial 7.

Prepare the front section of the main bandswitch for mounting as follows: Rotate the switch shaft all the way clockwise as viewed from the front. Refer to Figure 15 to identify the tag numbers on the switch. Remove the extra nuts from the switch mounting studs and lay them aside temporarily.

Mount the brass coupler to the rear end of the front section of the bandswitch and tighten the grub screws at that end only.

Expand tags A11 and A12 on the switch with a small spike shaped instrument such as the tang of a small file so that they will accommodate heavy gauge bare wire.

Connect a heavy gauge bare wire 2.5/8" long to switch tag A11 (S). Form as shown and leave the other end free.

Cut one lead of a .001 μ F mica capacitor to $\frac{3}{4}$ " and connect to tag B10 (S). Leave the other end free. Position the capacitor as shown in Figure 15.

Slide the hardware shown in Figure 15 on to the switch shaft and leave it loose.

Now insert the switch shaft in the front chassis apron hole far enough that the front section will engage the rear section switch shaft. The wafer of the front switch section should be positioned as in Figure 15.

Use the extra nuts that came with the switch along with the lockwashers to fasten the studs to the driver shield plate. Include a solder tag as shown.

Now tighten the foot of the bracket holding the rear switch section. If this appears to place tension on the switch shaft, use a fibre washer or lockwasher under the foot. Solder the leads that run from this switch section to the coil taps and the feedthrough insulators.

Tighten the grub screws on the rear end of the brass switch coupler and check switch rotation.

Temporarily connect a knob to the main bandswitch. Rotate the switch fully anticlockwise and then one position clockwise. Position the VFO switch fully anticlockwise and be sure the cable clears the switch mechanism.

Set the driver plate on the bandswitch shaft as shown in Figure 16B and secure with a 4BA x 3/8" hex head screw. Some experimentation may be required to obtain optimum position for the driver plate. Note that with both switches fully anticlockwise, both VFO and transmitter stages are in the 160 metre position. As the bandswitch is moved to the 80 metre position, it should just clear the left hand projection of the VFO switch and engage the right hand projection on the VFO plate without moving the VFO switch. As the bandswitch is moved to 40 metres, the VFO switch should move one position. Switch through 40 metres, 20 metres, 15 metres and 10 metres with bandswitch. The plate should clear the right hand projection and engage the left hand projection at the 10 metre position without moving the VFO switch. When switching from 10 metres back to 160 metres, the device should operate smoothly in the reverse order.

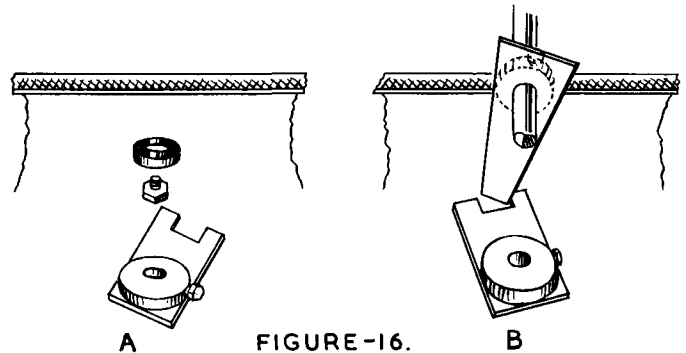

FIGURE-16.

Connect the free end of the .001 μ F mica capacitor on the front section of the bandswitch to the earth tag on the switch mounting stud (S). See Pictorial 7.

Slip a 2. 1/8" length of sleeving over the lead coming from tag 1 of the 20 metre oscillator coil and connect it to B5 of the bandswitch (S). This completes the oscillator section wiring.

CAUTION: When wiring the driver coil to the bandswitch, be sure the leads are not twisted around each other. Dress them neatly down through the coil and separate as much as possible. Refer to Pictorials 7 and 9.

Cut a **BLACK** wire to a length of 4" and strip back at both ends. Pass one end of this wire through the rivet hole at tag 1 of the low frequency driver coil on top of the chassis (S).

Connect the other end of the wire to tag A4 (S) of the bandswitch.

Cut a **BROWN** wire to a length of 7. 5/8", strip both ends and insert the wire up through the centre of the low frequency driver coil. Connect one end to switch tag A3 (S). Leave the other end free.

Cut a **RED** wire to 7", strip both ends and insert it up through the coil as in the previous step. Connect one end to A2 (S) and leave the other end free.

Cut and strip an **ORANGE** wire to 7" and position in the same fashion with one end connected to A1 (NS).

Cut and strip a **YELLOW** wire to 6. 3/8", position as with the other wires and connect one end to A12 (NS).

Select the 10 and 15 metre driver coil and connect long end to A12 (S) and the other end to the solder tag on the feedthrough insulator on the driver shield plate (S).

The heavy gauge wire coming from A11 should now be connected to the centre tap on this coil (S).

Turn the chassis right side up and connect the coloured wire to the low frequency driver coil tags as follows:- Refer to Pictorial 9 to identify the tag numbers.



BROWN wire to tag 2 (S).
RED wire to tag 3 (S).

ORANGE wire to tag 4 (S).
YELLOW wire to tag 5 (S).

This completes the wiring of the driver stage.

Return the chassis to its back apron and turn your attention to the final amplifier portion of the RF compartment, see Pictorial 8.

Mount the 1-way tagstrip at point Z. Include a solder tag and position as shown.

Note the three 5/32" holes in the rear apron of the chassis adjacent to the coaxial socket. Mount the three section antenna loading capacitor in this location using 4BA x 5/8" screws and 3/8" spacers. Refer to Figure 17. Leave screws loose.

Refer to Pictorial 8, and mount two solder tags on the two tapped holes provided on the capacitor. Use 4BA x 1/8" cheese head screws and solder tags. Position as shown. Do not use longer screws.

Run a piece of heavy gauge wire from one earth tag mounted on the tuning capacitor fixing screw. Bend it upward, clearing the shaft, and slip it through both solder tags on the loading capacitor and then down along the edge to the solder tag under the coaxial socket. Solder all 4 connections.

Pre-form a piece of heavy gauge wire as shown in Pictorial 8. Connect the 1/4" end to the centre tag of the coaxial socket (S). Bend the wire so that it rests on tags 2, 3 and 4 on the loading capacitor. Bend tags up slightly if necessary. Solder the three connections, then dress the wire over to both tags at CZ on the bandswitch (S). Make sure wire does not short to capacitor frame.

- () Place the shaft coupling on the loading capacitor shaft, then insert the 10 1/2" long extension shaft through the chassis front. Assemble the hardware on the shaft as shown in Figure 17, then through the driver shields. Centre the coupler on the two shafts and tighten the grub screws. Now tighten the capacitor mounting screws.

Select the 160 metre section of the final tank coil (wound on a 7/8" ceramic former) and mount it on the side apron of the 6146 sub-chassis as shown in Pictorial 8. Use a 4BA x 3/8" hexagonal screw and mount a 1-way tagstrip on the other side of the sub-chassis to the coil. Bend this tagstrip upwards to clear valveholders.

Connect the outer end of the 160 metre loading coil to both tags C5 on the bandswitch (S), trim off excess wire.

Connect the inner end of the 160 metre loading coil to both tags D6 on the bandswitch (S), trim off excess wire.

Select the two 10 KΩ 10 watt resistors and connect one from the solder tag on the feedthrough insulator (S) to the rear tag of the 1-way tagstrip in the 6146 sub-chassis (S). Use full lead length on this resistor.

Connect the other 10 KΩ resistor ^{TO} ~~from~~ the same tagstrip (S) to pin 3 of valveholder A (S). Use the full lead length on the valveholder end and cut the other end to an appropriate length to let the resistor run parallel to the chassis. *leave the other end free*

This completes the wiring of the RF compartment.

FINAL ASSEMBLY AND WIRING

Connect a mains RF filter choke wound on a tufnol former and indicated with a white spot from the 1-way tagstrip Z on the chassis centre brace (S) to pin 1 of the rear apron octal socket (S). (See Pictorial 10.)

Connect a .005 μF disc ceramic capacitor from the other tag (NS) to the adjacent earth solder tag (S).

Connect a BLUE wire from the tagstrip (S) to tag 1 of the ANODE switch M (S). Run the wire against the chassis centre brace.

Locate the meter switch and identify the switch tag numbers by referring to Figure 18. Use thin gauge wire to tie switch tags 4, 9 and 12 together and leave 3 1/2" of wire extending from tag 12. Solder these connections. Use sleeving.

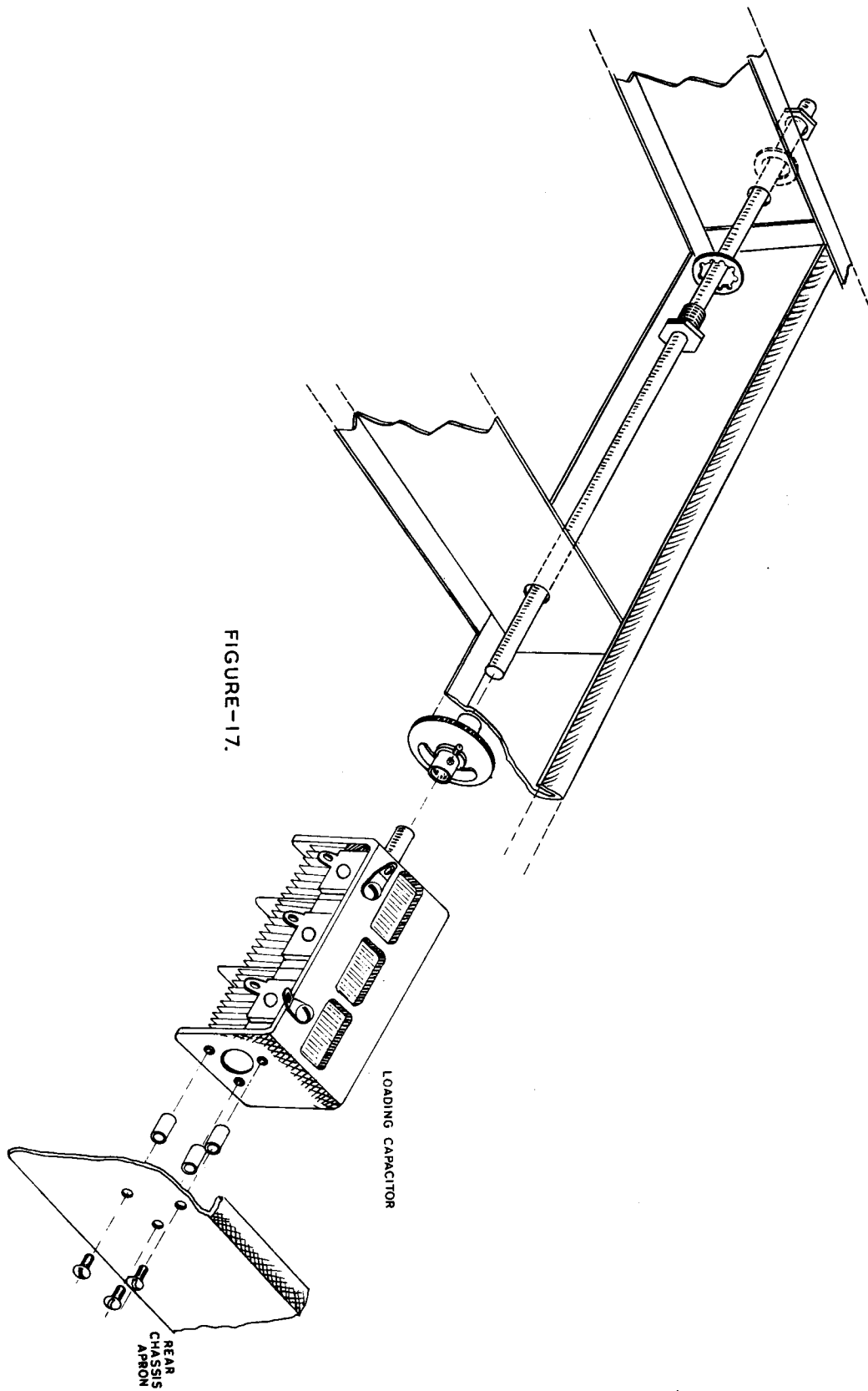

The switch may now be temporarily mounted so that its wiring can be completed. For convenience, a special switch bracket has been included to facilitate switch wiring before the panel is mounted. The bracket is shown in Figure 18. Temporarily mount one end on the audio gain control G and mount the switch through the hole in the other end.

- () Cut and strip each of the wires to appropriate length so that the cable will lie down against the chassis and come straight up to the meter switch. Connections should be made as follows:-

Two VIOLET leads on switch tag 11 (S).

GREY lead on switch tag 10 (S).

WHITE lead on switch tag 8 (S).

YELLOW lead on switch tag 6 (S).

BROWN lead on switch tag 5 (S).

RED lead on switch tag 3 (S).

BLUE lead on switch tag 2 (S).

Connect a 4" RED wire to tag 1 (S) and leave the other end free.

Connect a 4½" BLACK lead to tag 7 (S) and leave the other end free.

Select the front panel and prepare for mounting by first installing the meter in its place. Mounting hardware is supplied with the meter, but when mounting replace the flat washers with 6BA shakeproof washers from the kit. Mount with the meter mounting studs through the appropriate panel holes. In placing nuts over the studs, mount solder tags under the two lower mounting studs as shown in Pictorial 9. Tighten all four nuts securely.

Place two flat fibre washers onto the two meter terminals, leaving one nut still threaded to each terminal close up to the rear of the meter.

Now slip the metal shield over the back of the meter. Mount two fibre shoulder washers followed by two brass flat washers followed by two solder tags and two nuts onto the meter terminals. Do not over tighten.

Mount a .005 μ F disc capacitor from terminal 1 of the meter (NS) to the nearby solder tag (NS).

Mount a .005 μ F disc capacitor from terminal 2 of the meter (NS) to the nearby solder tag (S).

Mount the Heathkit motif to the front panel and secure on the rear side with two spring steel clips.

Mount the main HT neon indicator in the hole near the motif. Press in the indicator until the tabs spring outwards and hold the component firmly in place.

Select the two 3/8" long bushes and slip a 3/8" lockwasher on each one. Install one of these bushes in the DRIVER shaft hole on the panel and one in the AMPLIFIER shaft hole. Use a 3/8" flat washer and nut to secure each bush. Tighten the driver and amplifier bushes securely.

Select the ¼" long bush and mount in FREQUENCY hole in the panel. Omit the lockwasher and secure with a flat washer and nut. Do not tighten yet.

Prepare the main chassis to receive the panel by removing the nuts and flat washers from controls on the front chassis apron. Also remove the temporary bracket that was used to support the meter switch.

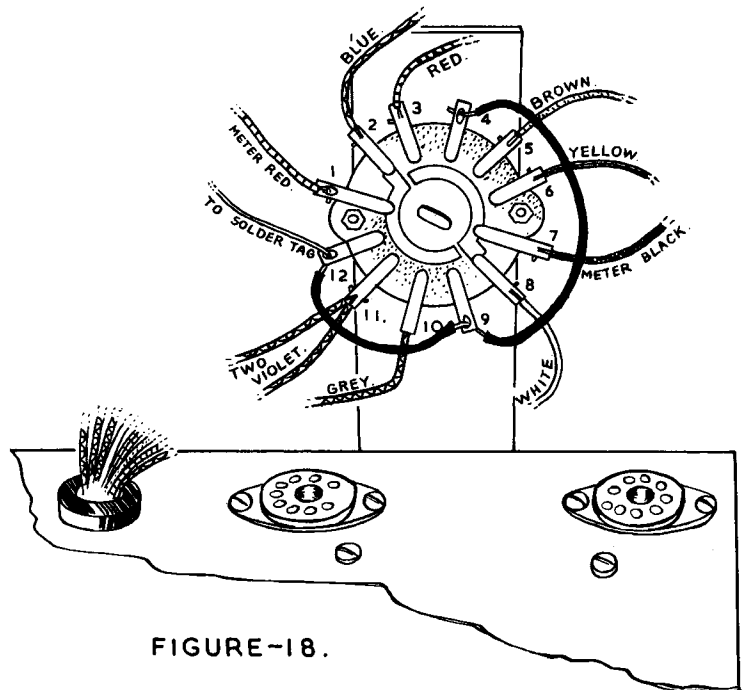
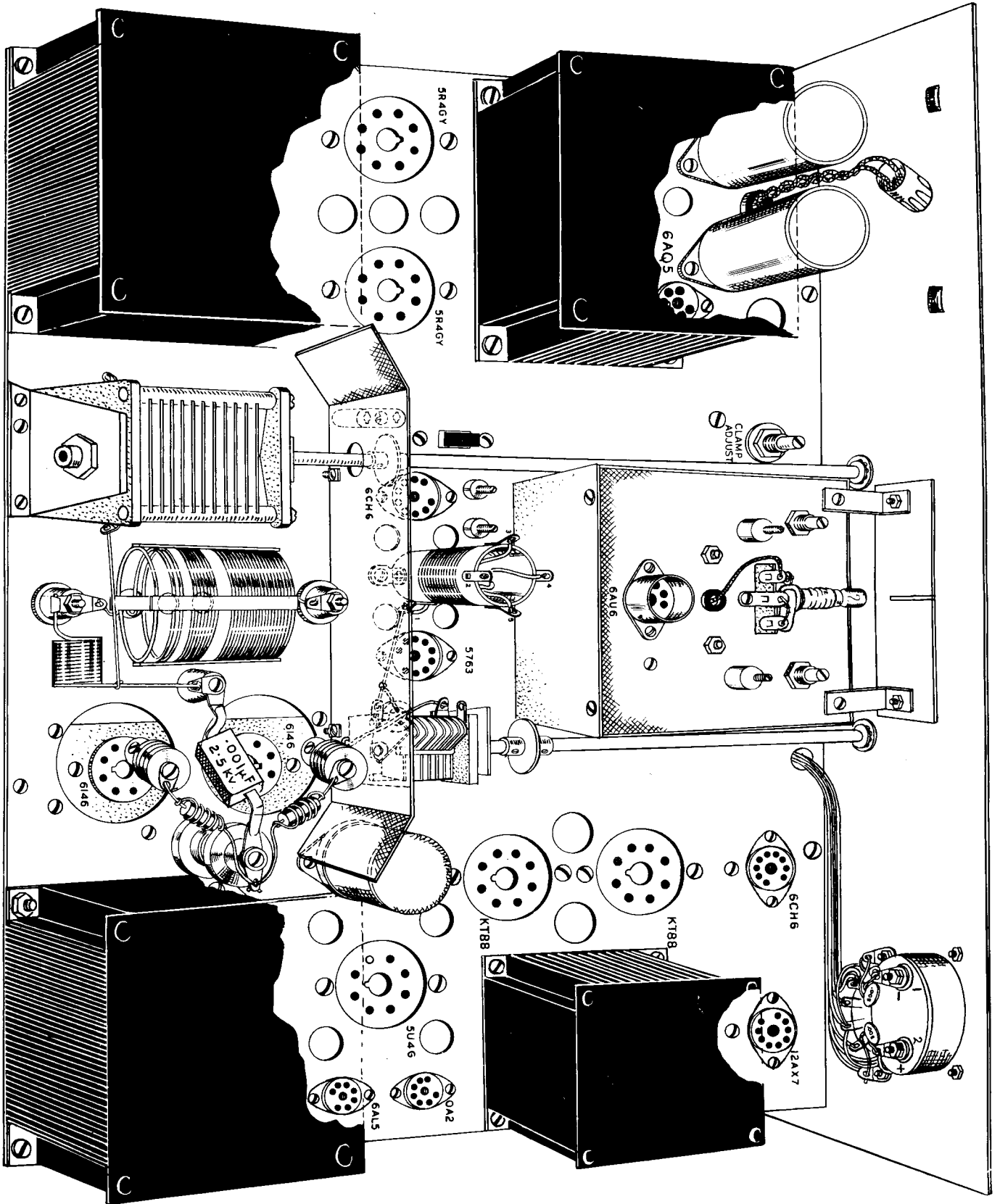

FIGURE-18.

PICTORIAL-9.



Mount the panel, taking care to guide the panel over the various bushes etc.

With the panel aligned carefully over the controls, place flat washers and nuts on the control and switch bushes and draw up finger tight.

When properly in position, secure all nuts on controls and switches on the bottom row of the front panel.

Mount the meter switch in the appropriate hole just below the meter, using a 3/8" flat washer and nut on the shaft.

To connect the meter into the circuit, connect the free end of the 4 1/2" BLACK wire to meter tag 1 (S). See Pictorial 9.

Connect the bare wire from the switch through the solder tag on the lower left meter mounting stud (S).

Connect the 4" RED wire to the positive meter tag 2 (S).

Insert the 6146 final amplifier valves in their valveholders and fit the aluminium top caps to the valves, only tightening the grub screws sufficiently to ensure a good fit. On top of the caps, fit a 4BA solder tag, using 4BA x 1/4" screws.

Solder both parasitic chokes to the two solder tags mounted on the top caps. Leave sufficient length of lead to allow for future removal of the top caps.

Connect a length of heavy gauge bare wire from the PA tuning capacitor rear stator tag (S) to the anode end of the 10 metre PA coil (S). See Pictorial 9.

Locate the shafts of the driver tuning capacitor and final amplifier tuning capacitor on top of the chassis. Install a flexible coupling on each shaft and tighten securely.

Mount a 6.7/8" long 1/4" shaft rod through the driver bush and into the coupler of the capacitor. Tighten the grub screw in the coupler hub.

Mount a 9.1/8" x 1/4" shaft through the amplifier bush on the front panel and into the coupler hub on the capacitor. Tighten the coupler hub grub screw.

- () Move the VFO frequency control bush in its slot until the shaft rotates freely. Tighten the 3/8" nut on the bush when it has been set properly. If the entire bush turns when attempting to tighten it, hold the bush from the back with a thin bladed screwdriver or a table knife while tightening it.
- () Lightly oil all extension shafts at their front panel bushes with light machine oil
- () Install a large diameter knob on the VFO frequency shaft and tighten securely.
- () Install a large diameter knob on the main bandswitch shaft. Set the switch in the 160 metre position and set the pointer on the knob to the 160 metre mark on the panel. Tighten securely.
- () Move the final amplifier tuning capacitor to full mesh and install a large knob on this shaft with the white pointer at 100 on the panel scale.
- () Move the driver tuning capacitor to full mesh and install a large knob on the shaft with the white pointer at 100.
- () Move the meter switch to full clockwise position and install a small knob on the shaft with the white line pointing to MOD.
- () Move the audio gain control fully anticlockwise and install a small knob with the white line to 0 on the panel.
- () Move the CW-PHONE switch fully anticlockwise and install a small knob on the shaft with the white line pointing to CW.
- () Set the "drive control" fully anticlockwise and install a small knob with the pointer at 0.
- () Set the variable loading capacitor to full mesh and install a small pointer knob with the marker pointing at the 0 on the panel. This control will then increase the loading when moved from 0 to 10 on the panel scale. It is possible to rotate this control beyond mark 10 but this loading position will not normally be used.

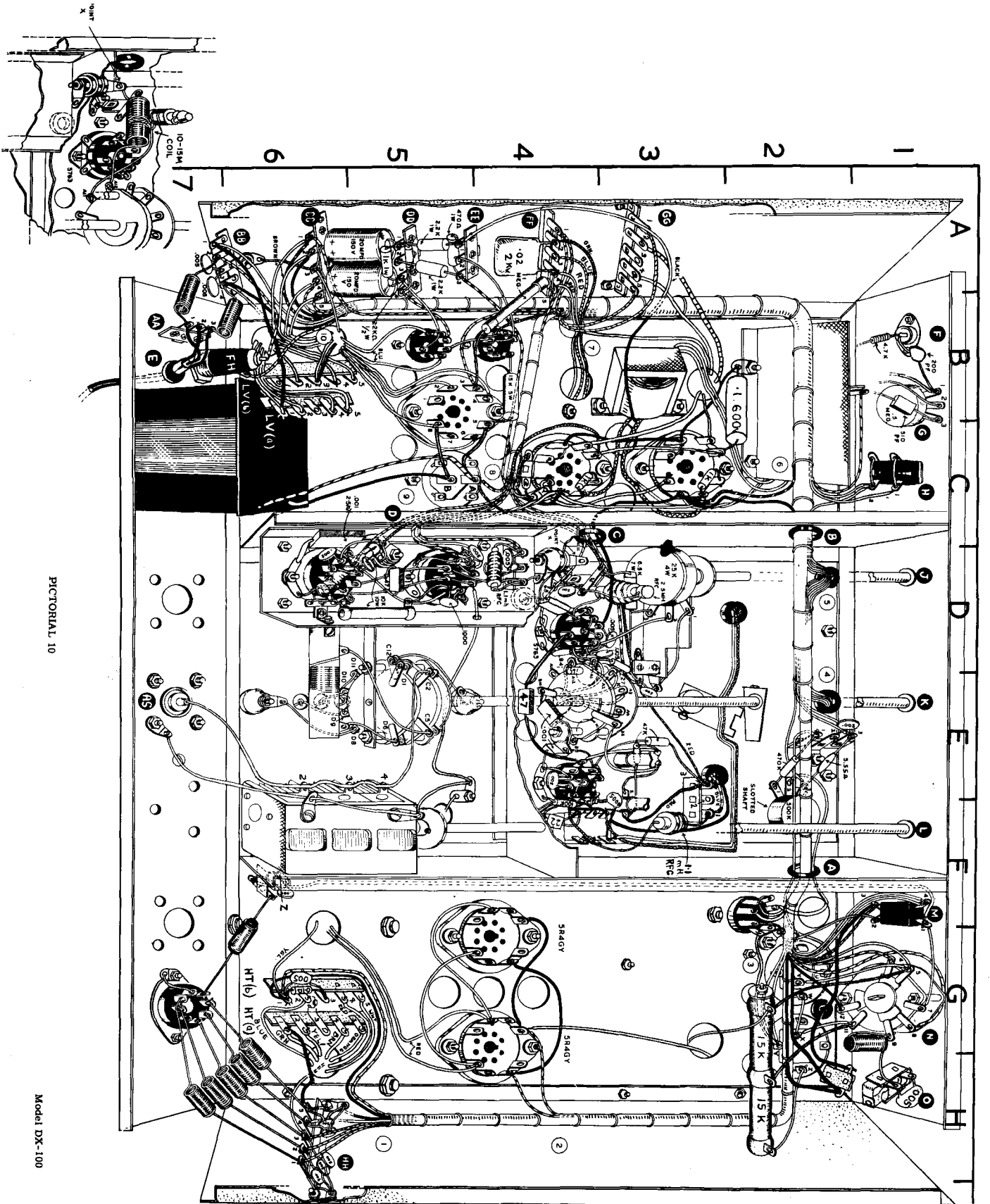

PICTORIAL 10

Model DX-100



- () Twist together the two RED neon indicator leads, pass them down through the nearest 3/8" grommet, connect one RED lead to tag 3 of toggle switch M (S). Connect the other RED lead to the unsoldered end of the 1-way tagstrip (S). See Pictorial 10.

In a previous step the LV supplies and main HT transformer primaries were set for 100-150 volts AC or 200-250 volts AC operation.

Connect the free end of the GREY wire coming from tag BB1 to LVal (S).

Connect the free end of the GREY wire coming from tag HH5 to HTa1 (S).

Connect the free end of the GREY wire coming from tag BB4 as follows, then solder:

For 95-110 volts AC or 195-210 volts AC to LVb2.
 For 110-125 volts AC or 210-225 volts AC to LVb4.
 For 125-140 volts AC or 225-240 volts AC to LVb5.
 For 140-150 volts AC or 240-250 volts AC to LVa5.

Connect the free end of the GREY wire coming from tag HH3 as follows, then solder:

For 95-110 volts AC or 195-210 volts AC to HTb2.
 For 110-125 volts AC or 210-225 volts AC to HTb4.
 For 125-140 volts AC or 225-240 volts AC to HTb5.
 For 140-150 volts AC or 240-250 volts AC to HTa5.

- () Insert all valves in the proper valveholders. Refer back to Pictorial 9. Install the VFO dial lamp in its holder. Fit the screening can to the 6AU6 VFO valve.

NOTE: Before switching on, it would be advisable to carry out a stage by stage check of all wiring and component positioning, with special attention to parts of the transmitter where high voltages will be present.

A comprehensive check with an ohmmeter will, in many cases, save time, money and possible damage to components.

Mount the four rubber feet to the outside of cabinet using 2BA x 3/8" hardware.

- () When the calibration has been completed, the transmitter can be installed in its cabinet using ten 2BA x 3/8" chrome headed screws and eight large sheet metal screws.

CONGRATULATIONS! - THIS COMPLETES THE ASSEMBLY AND WIRING OF YOUR HEATHKIT MODEL DX-100U TRANSMITTER.

G U A R A N T E E

Daystrom Limited guarantee subject to the following terms to repair or replace free of charge any defective parts of this Heathkit (with the exception of cathode ray tubes and valves referred to hereunder) which fail owing to faulty workmanship or material provided the defective parts are returned to Daystrom Limited within 12 months from date of purchase:—

1. This guarantee is given to and for the benefit of the original buyer only, and is and shall be in lieu of, and there is hereby expressly excluded, all other guarantees, conditions or warranties, whether express or implied, statutory or otherwise, as to quality or fitness for any purpose of the equipment, and in no event shall Daystrom Limited be liable for any loss of anticipated profits, damages, consequential or otherwise, injury, loss of time or other losses whatsoever incurred or sustained by the buyer in connection with the

purchase, assembly or operation of Heathkits or components thereof.

2. No replacement will be made of parts damaged by the buyer in the course of handling, assembling, testing or operating Heathkit equipment.

3. The purchaser shall comply with the Replacements Procedure laid down in the relevant Heathkit Manual.

4. Daystrom Limited will not replace, repair or service instruments or parts thereof in which acid core solder or paste fluxes have been used and in such event this guarantee shall be completely void.

Note: The Cathode Ray Tubes and Valves forming part of the equipment are guaranteed by the respective manufacturers. It should be noted that their guarantee is given only in respect of faulty workmanship and/or material and does not cover misuse or consequential damage.

TUNING INSTRUCTIONS

NOTE: See Figure 19 for a description and the location of all operational controls on the transmitter before beginning the tuning procedure. A knowledge of each control function will assist in accomplishing the tuning without difficulty.

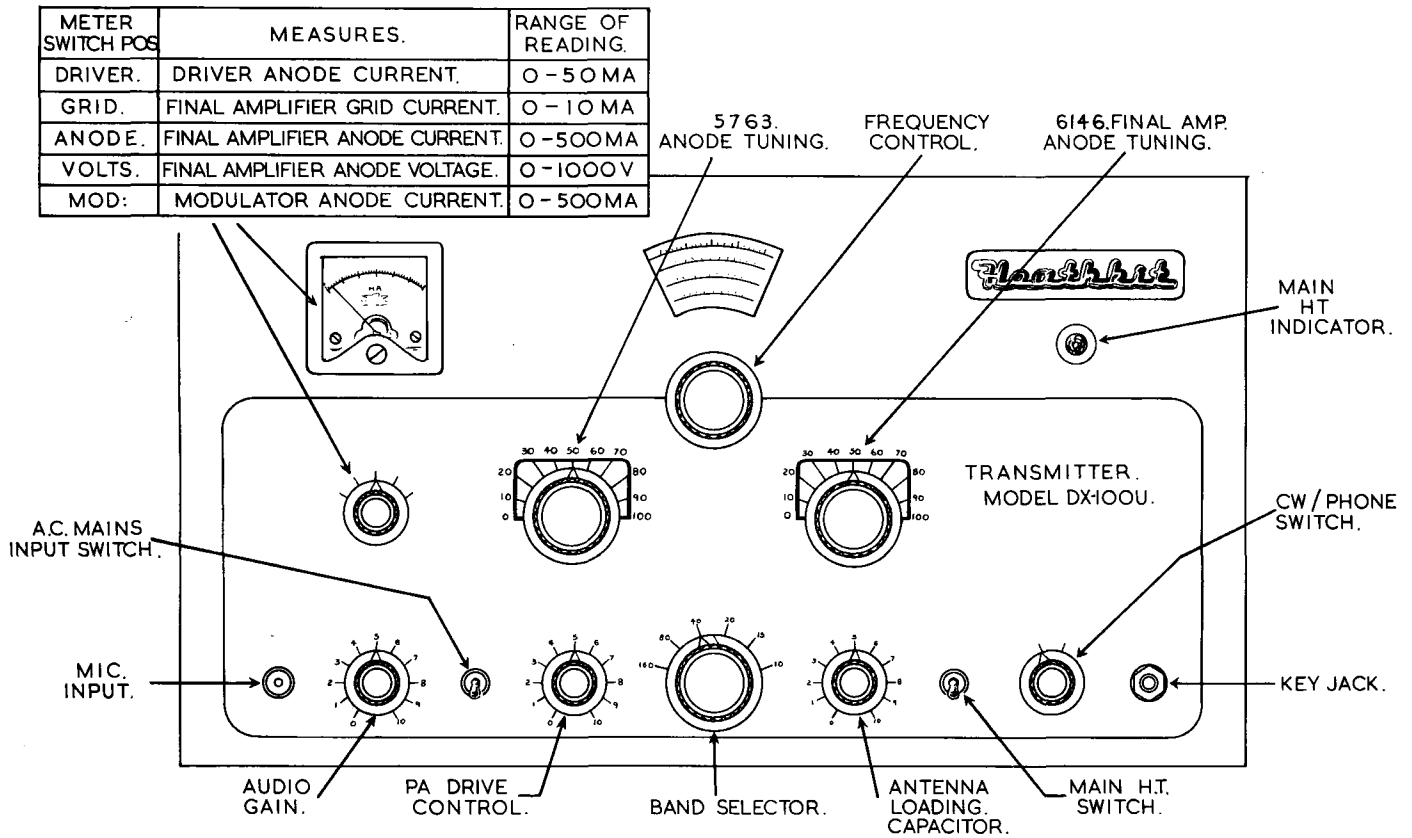

FIGURE -19.

- () Plug a crystal into the crystal socket. Select a crystal that will fall within one of the amateur bands, preferably a frequency lower than 40 metres.
- () Connect a 100 watt light bulb to the coaxial socket on the back chassis apron to act as a dummy antenna. This may best be done with the bulb inserted in a porcelain socket. One lead from the bulb should connect to the centre portion of the connector and the other should connect to the chassis. A wander plug and crocodile clip are convenient for the connections or a short length of coaxial cable may be fitted with a connector at one end and soldered to the light bulb at the other.

() Before applying power, set the control knobs and switches as follows:

AUDIO GAIN	- anticlockwise
MAINS	- off
XTAL-VFO	- Xtal (Pictorial 4)
DRIVE	- anticlockwise
BAND	- set bandswitch to proper band for crystal frequency used
LOADING	- set control fully anticlockwise
ANODE	- off
CW-PHONE	- CW position
METER	- grid
DRIVER	- 50
FREQUENCY	- no special setting at this time
AMPLIFIER	- 50
CLAMP	- fully anticlockwise. (See Note.)

NOTE: This is the screwdriver adjustment on the top side of the chassis immediately behind the panel and adjacent to the VFO enclosure and the 6AQ5 valves. (See Pictorial 9.)

CAUTION: BEFORE APPLYING POWER TO THE TRANSMITTER, IT SHOULD BE NOTED THAT LETHAL VOLTAGES ARE PRESENT BOTH ABOVE AND BELOW THE CHASSIS. CARE SHOULD BE EXERCISED NOT TO TOUCH ANY HIGH VOLTAGE POINTS WITH YOUR HANDS. WELL INSULATED TOOLS SHOULD BE USED FOR BEHIND THE PANEL ADJUSTMENTS.

NOTE: At this point, the scale on the meter should be studied carefully to determine just how the meter reads for the various positions of the meter switch. First note that the meter has two scales; one from 0 to 500 and one from 0 to 10. The scales should be interpreted as follows:

METER SWITCH POSITION	MEASURES	RANGE OF READING
Driver	Driver anode current	0-50 mA
Grid	Final amplifier grid current	0-10 mA
Anode	Final amplifier anode current	0-500 mA
Volts	Final amplifier anode voltage	0-1000 volts
MOD.	Modulator anode current	0-500 mA

- () Insert the fuse and connect the transmitter to the AC mains. Temporarily remove the 5U4G valve.
- () Turn the mains switch to ON and check to be sure that all the valves light up. Switch the mains off and recheck your wiring if any overheating is observed. Replace the 5U4G valve in its valveholder.
- () If nothing unusual is observed under these conditions, advance the drive control slightly. Then adjust the DRIVER tuning control for a peak reading. CAUTION: Do not hold the reading above 6 mA for more than an instant. See if at least 6 mA is available through adjustment of the DRIVE control with the DRIVER tuning peaked. Leave grid drive set to 5 mA. Note position of grid DRIVE control knob with 5 mA on the meter so that you can return to this setting later. This indicates proper functioning of crystal oscillator and driver stages.
- () Move the XTAL-VFO switch to VFO and peak the VFO FREQUENCY knob until a maximum reading is obtained on the meter. Increase or decrease the grid DRIVE to maintain the 5 mA reading. The VFO frequency dial indication is not significant at this time. VFO calibration will be accomplished later. If at least 6 mA of drive can be obtained, it indicates that the VFO is working also.
- () To test the final amplifier, return the grid DRIVE control to full anticlockwise position, reducing the drive to zero. Move the meter switch to anode and the anode switch to ON. Turn this switch off immediately in case of any arc, apparent overload or an excessive meter reading (over 300 milliamperes). Normally the meter should not read, or should read only slightly, up-scale.

CLAMP ADJUSTMENT

CAUTION: Make the following adjustment as rapidly as possible so as to prevent damage to the 6CH6 valve which will be drawing excessive current during adjustment.

- () Move the XTAL-VFO switch to XTAL, without a crystal in the socket. Now quickly advance the clamp control slightly until the meter begins to rise, then retard it back until it just returns to zero. Be sure it is not retarded beyond zero in either direction. Now switch back to VFO position.
- () With the meter still in the anode position, adjust the grid DRIVE control with one hand and AMPLIFIER tuning with the other. Advance the drive slowly while simultaneously tuning the amplifier for minimum on the meter until the grid DRIVE control knob is positioned as it was previously for 5 mA drive level. CAUTION: Do not let the amplifier anode current exceed 300 mA under any circumstances. With the anode current dipped to minimum by the amplifier tuning, return the meter switch to GRID and set the grid drive to 5 mA. Switch back to anode and dip the AMPLIFIER tuning again. The final anode current should now read in the lower portion of the meter scale.

NOTE: On some bands it is possible to obtain two dips with the AMPLIFIER tuning. To eliminate the possibility of doubling in the amplifier, always select the dip at the highest reading on the AMPLIFIER tuning. (Capacitor plates near full mesh.)

- () Rotate the LOADING control a little at a time, dipping the amplifier after each time. The meter reading should increase as control is tuned clockwise, as should the light bulb brilliance. Adjust the LOADING control (still maintaining a dip with the AMPLIFIER tuning control) for normal operating load of about 250 mA on the meter. Recheck grid current to be sure it still reads 5 mA. If reading has dropped, increase the grid DRIVE control to restore 5 mA reading. Now return the meter switch to the anode position.
- () Phone operation may be tested as follows: With all other controls set the same, turn the ANODE switch to OFF and move the CW-PHONE switch to PHONE. Connect a high impedance microphone to the MIC input socket. Move the ANODE switch ON. The anode current reading should be slightly lower than for CW (240 mA). Move the meter switch to the MOD. position and speak into the microphone while slowly advancing the audio GAIN control. The control should be set so that the audio peaks reach about 125 mA. Without modulation, the reading will be around 50 mA. The light bulb used for a dummy load should peak upward in brilliance with peaks in audio modulation.

CALIBRATION

If the kit constructor has access to an LM or BC frequency standard, they are excellent for calibration. The other alternative is to accumulate as many crystals in the bands concerned as possible. The crystals preferably should be near the edge of the bands. The crystals may be inserted in the crystal sockets of the transmitter and compared to the VFO frequency by means of a nearby receiver having a BFO. If the frequency meter is used the frequency meter and VFO signals can beat against each other in the receiver. Before beginning calibration, allow VFO, frequency meter and receiver to warm up for one-half hour or more. If a BC-221 frequency meter or equivalent is used (do not use ordinary radio signal generators) it should be set to 1750 kc. If the crystal oscillator is used, have frequency as near as possible to 1750 or 3500 kc.

During the alignment procedure, the DRIVE control should be fully anticlockwise, the CW-PHONE switch should be on CW and the ANODE switch should be OFF. NOTE: If a frequency meter is used for calibration, the frequency meter signal and the VFO signal should zero beat against each other in a receiver with the BFO off. When using crystals for calibration, set the receiver to the crystal frequency with the BFO on and zero beat the BFO in the receiver. Align the VFO for zero beat without changing the receiver tuning and the VFO frequency will be the same as the crystal frequency. Apart from this, the following procedure may be used for either method of calibration. Refer to Figure 20 for location and identification of the various calibrating adjustments.

NOTE: It should be noted that the trimmer capacitors (A and C in Figure 20) are used to set a definite frequency point on the dial, while the coil slugs (B and D in Figure 20) determine the overall frequency range covered by the dial. The capacitors are set to a particular frequency near the low end of the band and the slugs are adjusted so that the high frequency end of the band coincides with the dial reading. These two adjustments interact with each other and therefore should be adjusted alternately until optimum overall calibration is obtained.

Set the VFO to 1750 kc if a frequency meter is used or to the crystal frequency used near the low end of the band. The main bandswitch may be left in the 160 metre position for either 160 metre or 80 metre crystals.

Adjust trimmer A for zero beat in the receiver. Note that the zero beat will be against the frequency meter if available or against the receiver BFO as previously set to zero beat against the crystal oscillator. Now use a crystal near the high end of the band or move the frequency meter up to a frequency of approximately 2000 kc. Reset the receiver as in the previous step. Tune the VFO to the high end of the band and note the reading on the calibrated dial scale. If the dial calibration exceeds the frequency used, adjust slug B clockwise. If the dial reading is less than the frequency used, adjust slug B in an anticlockwise direction. Then go back to the low frequency end and readjust trimmer A. Repeat the process until calibration is achieved at both ends of the band.

Set the dial to the scale reading 7-14-21-28 MC. Repeat the procedure outlined above for the higher bands. Move the bandswitch to the 40 metre position and leave all other controls the same. The receiver and signal sources (crystal or frequency meter) must operate between 7 and 7.425 mc. Trimmer C and slug D in Figure 20 operate the same on this band as trimmer A and slug B on the lower band.

ADJUSTMENT OF BUFFER COILS

Set the bandswitch to the 10 metre position and the VFO dial to 28.6 mc. Advance the DRIVE control until a grid current reading can be obtained on the meter when tuning the driver stage for a peak. Adjust slug F (as shown in Figure 20) for a maximum reading on the meter.

Now switch the band selector to 15 metres and set the dial to 21.3 mc. Peak the driver stage again and adjust slug G for maximum reading on the meter.

IN CASE OF DIFFICULTY

Mistakes in wiring are the most common cause of difficulty. Consequently, the first step is to recheck all wiring against the pictorials and schematic diagrams. Often having a friend check the wiring will locate an error consistently overlooked.

Also, with miniature valveholders there is a possibility of shorts between adjacent valveholder tags due to the close spacing. This should be checked and if any doubt exists, the tags should be prised apart until obvious spacing can be seen between them.

Sometimes apparently good solder connections will have an insulating coating of resin between the wire, the tag and solder. This is often the case when insufficient heat was applied in soldering. An ohmmeter check of any questionable connections will test for this condition. Naturally, all voltages should be "off" for such tests.

The transmitter is fused at the chassis rear. A glass cartridge fuse is supplied for the live side of the mains input with a rating not in excess of 5 amperes. Should it be found that fuses consistently blow whenever the equipment is plugged in and the POWER switch is turned ON, resistance tests of the low voltage power supply should be made in accordance with the following chart. If a fuse blows whenever the ANODE switch is moved to the ON position, the main HT power supply should be checked with an ohmmeter as outlined in the chart on Page 57. In either case it is important that the power switches be OFF and the mains lead removed when the resistance measurements are made. As additional insurance against shock, a screwdriver blade should be used to short from the chassis to the hot end of the bleeder resistor and from the chassis to each of the filter capacitors so that they will be thoroughly discharged.

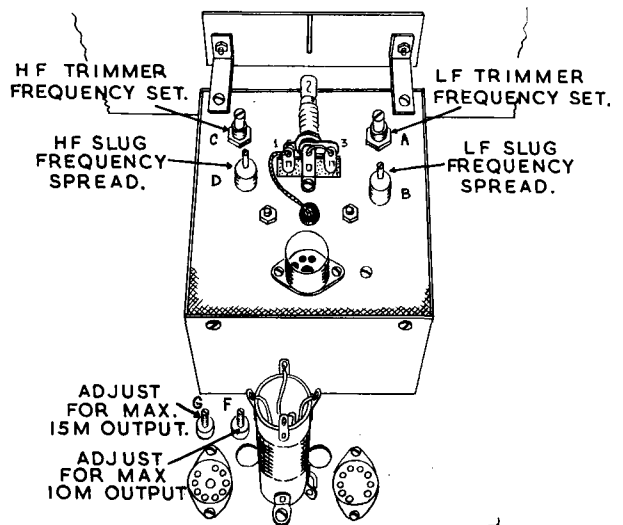

FIGURE-20.

Be sure to read the circuit description at the front of the manual so that "cause and effect" reasoning may be employed as the search for trouble progresses. If some difficulty still persists after the steps outlined have been completed, attempt to localise the trouble to a particular stage in the transmitter circuit. Use the tuning procedure as a basis for localisation and refer to the block diagram and schematic to visualise circuit relationships. The panel meter and station receiver are extremely valuable tools to use in locating trouble.

RESISTANCE MEASUREMENTS

TEST CIRCUIT	TEST POINT	OHMS TO EARTH
Low Voltage Supply	Low Voltage Filter	32 K Ω
Main HT Supply	High Voltage Filter	30 K Ω
Bias Supply	Pin 2 or 7 6AL5 valve	5.6 K Ω
PA Grid Circuit	6146 Grid Bus-Bar	6.7 K Ω
Oscillator Screen	Pin 8 6CH6 valve	60 K Ω
Modulator Screen	Pin 4 KT88 valves	15 K Ω
Final Amplifier Screen	Pin 3 6146 valves	52 K Ω

If a grid current reading cannot be obtained at the panel meter, the receiver may be used to check VFO and/or crystal oscillator operation. Connect a short piece of insulated wire to the receiver antenna terminal and bring the wire near the VFO or crystal oscillator valves. Tune the receiver to determine if a signal is being generated by the respective oscillator valves. If no signal is present, check the valves and notice the OAZ voltage regulator valve to see if it has a blue glow. If the OAZ shows blue, HT is present. If this valve is dark, check the HT supply. If only one of the oscillator circuits work, check the XTAL-VFO switch wiring.

If it should be determined that both oscillator stages are functioning properly, but still no grid drive can be obtained on the meter, turn the meter switch to the DRIVER position and advance the DRIVE control fully clockwise. The meter should read upscale, indicating anode current in the driver stage. No reading shows a defective driver valve, lack of DC operating potentials on the driver stage, an open cathode, screen or anode circuit, lack of coupling between oscillator and driver stages or detuned oscillator coils.

If, on the other hand, driver anode current can be obtained on the meter, try adjusting the DRIVER control for a dip in anode current. No dip could be caused by improperly connected driver tank coils or a poor connection to the driver tuning capacitor.

Should it be found that a dip can be obtained in driver anode current when tuning the driver, but still no grid current is available, the 6146 grid circuit may be open at some point. Note that the grid circuit includes a 1.1 mH RF choke, a shunt resistor for the meter, a 2.2 K Ω grid resistor and bias supply bleeder resistors. If an ohmmeter is available, measure the overall grid circuit continuity with the mains turned off. The reading should be in the vicinity of 6.7 K Ω . If such a test shows an open, check each grid circuit component separately to find the defective component or connection.

Assuming that grid current is available in the correct quantity, difficulty in the 6146 stage may manifest itself in the form of an excessive anode current reading, insufficient anode current or inability to obtain resonance when tuning the final amplifier.

Excessive anode current could indicate a shorted RF bypass capacitor in the final stage, lack of grid bias, detuned final tank circuit or miss-set loading control.

Insufficient anode current would suggest low anode voltage and this can easily be checked with the panel meter in the VOLTS position. If anode voltage is present but anode current is still low, the clamp control may be miss-set (see tuning procedure for proper adjustment) or the screen circuit may be shorted or open.

Failure to reach resonance when tuning the final tank circuit could indicate an incorrectly wired bandswitch or loading switch, a shorted loading capacitor or any other short or earth in the final pi-network circuit. Also, do not overlook the possibility that the frequency controls in previous stages may be incorrectly adjusted (see tuning procedure).

AUDIO CIRCUITS: CAUTION: When feeding a signal to audio stages, be sure transmitter is loaded and be sure to start with audio gain control fully anticlockwise, then advance slowly to proper level. Failure to observe this may cause the modulator transformer and associated circuit to become permanently damaged. Inability to obtain modulation when following the procedure outlined in the tuning instructions could be indicative of trouble in the speech amplifier or modulator circuits, or may simply show a defect in the microphone or cable. Isolate the trouble by disconnecting the microphone connector at the panel. Move the meter switch to MOD. and set the audio GAIN control fully anticlockwise. Touch the centre portion of the microphone connector on the panel with your finger and advance the audio gain control slowly. The meter will show modulation if the speech amplifier and modulator circuits are all right, pointing to trouble in the microphone or cable. No reading at all on the meter suggests a lack of screen voltage on the modulator. Check the wiring at the CW-PHONE switch. Screen voltage is obtained at the centre tap of the bleeder resistor. If the meter reads up to about 50 milliamperes, however, but does not increase above this value with signal input, the trouble is more than likely in the speech amplifier portion of the circuit.

With the high voltage anode switch OFF, speech amplifier output can be checked at the modulator control grids. Care should still be exercised, however, because the low voltage power supply is still on.

Connect a headphone or an AC voltmeter from grid to grid on the two modulator valves and apply audio signal to the input of the speech amplifier by touching your finger to the centre part of the microphone connector on the panel. No output under this condition could mean that one of the speech amplifier valves is defective. Have them tested or substitute new ones. The speech amplifier portion of the transmitter is straightforward audio circuitry and the conventional test procedure for such circuits can be applied. Access to this portion of the circuit may be had by removing all screws from the audio shield plate under the chassis. Remove the screws that hold the plate to the chassis and those that hold the tagstrips on the plate and the plate may be removed without any difficulty. The circuit components will support themselves temporarily.

INSTALLATION AND OPERATION

NOTE: It should be noted that it is an offence to operate a transmitting station without a transmitting licence. Information covering this can be obtained from your nearest Post Office. Great care has been taken in the design of the transmitter to prevent radiation outside the amateur bands. However, it is the direct responsibility of all radio operators to ensure that at all times their transmitter is radiating correctly and within the allocated bands.

EARTHING: The importance of a good earth that presents low impedance at all frequencies cannot be emphasised too strongly. What may be a perfectly satisfactory earth at 160 metres could place the transmitter considerably above earth at the higher RF frequencies. As an example, the length of the earth wire is sometimes critical. An 8 foot wire from the transmitter to earth would be a direct short at 160 metres but becomes one-quarter wave length at 10 metres and therefore places the chassis at a high RF potential. Some hints that will be of assistance in obtaining a good earth are:-

1. Connection for the earth should be made to cold water or well pipes and/or multiple pipes or rods driven approximately eight or more feet into moist earth. A salt solution poured around the earth rods will further increase the conductivity to earth. A more elaborate installation might include a system of wires approximately one-quarter wave length long laid a few inches under the surface of the earth in a grid or radial pattern. The use of one or all of these earthing systems may be combined to form a good earth reference.
2. The electrical connection to the earth point should consist of a short heavy conductor (12 swg.) wire or heavier, or copper braid. If a short earth wire is difficult to obtain because of transmitter location, several leads of random length may be used. The use of random leads lessens the possibility that all leads should become one quarter wave length at the frequency of operation. If the transmitter becomes hot at one particular frequency the addition of an earth wire cut to one-half wave length at this frequency may clear up the difficulty.

Some of the symptoms of inadequate earthing are manifested in the form of:-

1. Inability to load the antenna properly.
2. High RF potentials on the chassis or case of the transmitter.
3. Undue voltage strain on output circuit components.
4. Final anode current reading affected by touching the panel or case.

LOCATION: The transmitter should be located where free circulation of air is possible and objects should not be placed on the case as this might restrict the circulation of air. Good ventilation is essential to ensure maximum component life. A table or desk of adequate strength must be used to withstand the weight of the transmitter. The considerations mentioned with regard to earthing will also affect the selection of a good location, as will the point of entry of the antenna feeder.

OPERATION: The tuning procedure outlined previously will also apply when loading an actual antenna. Some special cases involving particular antenna types will require special consideration and will be covered under ANTENNAS.

A point not covered under the tuning procedure is the method by which the VFO may be made to beat with an incoming signal without placing the transmitter on the air. This is desirable to place the transmitter on the same frequency as the received signal. When operating phone, with the anode switch OFF, move the CW-PHONE switch to CW position. This energises the first three stages of the transmitter circuit. Enough signal will ordinarily be picked up by the receiver under these conditions that the VFO can be tuned for zero beat on the receiver with the incoming signal. If the frequency deviation is more than a few kilocycles, it will be necessary to retune the driver stage. Return the CW-PHONE switch to PHONE position. When the transmitter is again placed on the air, the final amplifier tuning should be adjusted appropriately to compensate for the frequency change.

When operating CW, simple depressing the key (with the ANODE switch OFF) will allow the operator to zero beat with the incoming signal on the receiver. Here again, if the frequency change is more than a few kilocycles, the driver and final stages should be retuned as outlined previously.

REMOTE CONTROL SOCKET: See Figure 21 for a diagram of this socket. This is the octal socket located at the chassis rear. It provides connections for external duplication of the functions of the anode switch and provides AC mains for antenna relay or receiver muting relay operation when the anode switch is on. In addition audio output up to 100 watts at 500Ω can be brought out from this socket for excitation of a higher power modulator. Pin 8 provides an auxiliary earth in the event that shielded cable is used for remote operation.

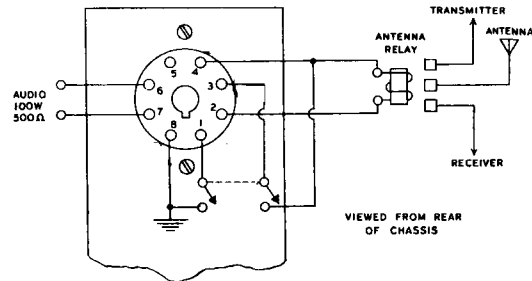

FIGURE-21.

Should the DX-100U be used as an exciter for a larger transmitter, RF excitation is available at the antenna output connector. Audio at 500Ω is available at the octal socket providing a slight circuit modification is first accomplished. To do this, refer to Pictorials 2 and 5 and locate tagstrip FF on the chassis base. To remove the high voltage from the modulation transformer secondary, remove the jumpers between tags 1 and 2, and 4 and 5 on strip FF. Install jumpers between tag 3 of FF and tag 1 of GG and between tag 4 of FF and tag 5 of GG. Then audio will be available between tags 6 and 7 of the remote socket.

An external switch may be placed in parallel with the anode switch by connection to tags 3 and 4 of the remote socket. When using a remote anode switch for phone operation, a double pole single throw switch or relay must be used to perform the full function of the anode switch. One set of contacts completes the circuit between tags 3 and 4 of the remote socket, while the other set completes the circuit at tags 1 and 8.

For operation of an antenna relay or receiver muting relay, AC mains is available between tags 2 and 4 of the remote socket when the anode switch is on and is removed when the anode switch is off.

ANTENNA CONSIDERATIONS WITH REGARD TO THE DX-100U TRANSMITTER

Although a Pi network tank circuit can and will abolish the necessity of a separate antenna coupler, and even aid in the suppression of harmonics, it is not a "cure-all" for antenna matching and never will be. It has definite limitations regarding both the impedance and reactance that it can handle.

The aerial loading control and the amplifier tuning control of the DX-100U will match antenna impedances in the range of 50 to 600 ohms, providing there is no capacitive or inductive reactance to tune out.

A transmitter, regardless of power, is no better than its radiator, and it is far more practical to increase antenna efficiency than to increase power. An example of this is a rotary beam with a 9 dB gain. This antenna would make the effective radiated power of the DX-100U equal to 800 watts.

One step toward efficient radiation is to choose an antenna which is resonant at the frequency used and presents little or no reactance to the transmitter.

High reactance in the antenna feed system is usually synonymous with high SWR (standing wave ratio). This means that a good percentage of the power from the transmitter is being reflected back from the antenna. Not only does this seriously impair the signal output but also can result in high voltages or currents appearing in the transmitter output circuits. This effect can cause extensive damage to the final amplifier components, and is often a cause of TVI.

Since there is no way of anticipating the type of antenna which will be used in conjunction with this transmitter, or even the individual characteristics of each installation, the following will be a general description of the advantages of some types and the probable objections of others.

END-FED HERTZ AND MARCONI ANTENNAS

This type of antenna consists merely of a single wire from one-quarter wave length to any even multiple thereof. One end of the wire is coupled to the transmitter and the other end supported in space. If this antenna is operated against earth, it is known as a Marconi antenna, while if the length is one-half wave length or more, it is known as a Hertz antenna. The greatest disadvantage of feeding a single wire is the necessity of bringing part of the radiating element into the radio room where its proximity to nearby objects increases losses. The greatest advantage of such an antenna is the simplicity with which it may be constructed and its compact size where space is at a premium.

In general any antenna consisting of a single wire, end fed, will result in a high impedance and indeterminate reactance at the transmitter. This often results in very high voltages. In this case, a separate coupler should be used to bring the impedance down to a range the Pi network will accept.

ANTENNAS HAVING FEED SYSTEMS

In the average station it will be found expedient to have the radiating portion of the antenna some distance away from the transmitter. This statement assumes that the amateur will have his antenna up high and clear of nearby objects, whereas the actual transmitter may be in the basement or any other room in the home. In such case, some form of transmission line must be used to connect the transmitter efficiently to the antenna. In many instances, the transmission line is of the "balanced" type in which neither leg of the line is earthed. Such transmission lines may be either tuned or untuned, but in either case, a balanced line must be fed through an antenna coupler or "balun" coils. The coupler also provides the means for matching the impedance of the antenna feed line. A typical antenna coupler circuit is shown in Figure 22.

Basically the antenna coupler is an impedance transformer, transforming the impedance of the transmitter to the impedance of the transmission line and antenna system. Referring to Figure 22, coil L1 should match the impedance of the coaxial cable as closely as possible at the frequency of operation. The circuit consisting of L2, C1 and C2 must tune to the transmitter frequency. If it is desired to series tune the antenna, the shorting bar between 3 and 4 is opened and the transmission line connected at these points. For parallel tuning, 3 is shorted to 4 and the transmission line connected to 1 and 2. Taps are provided on the coil L2 to facilitate matching the transmission line. Such a unit can be built up from this or other suggested circuits may be purchased commercially as a completed unit.

Folded dipoles having 300 Ohm ribbon for a feed line are very conveniently fed by using Balun coils. These coils convert the 300 ohm balanced line to a 72 ohm unbalanced coaxial line and are effective from frequencies of 1.8 to 30 MC. The folded dipole is primarily a one-band antenna, and is useful in preventing harmonic radiation.

There is a modified Windom antenna which is fed with 300 ohm ribbon. It resembles a dipole fed off centre with a balanced feed line and the off centre point is supposedly chosen to present a 300 ohm impedance to the feed point. This antenna is the subject of a great deal of controversy and we do not recommend its use. In contrast many hams enjoy good results with it.

The single wire dipole antenna fed with 72 ohm coax may be used as a multi-band antenna and being coaxial fed can be connected directly to the transmitter. However, the SWR will run a little high on bands other than the design centre.

Vertical antennas with a proper matching network at the base may be coax fed and will operate over several bands with good results.

A check of the older issues of Short Wave Magazine, R. S. G. B. Bulletin, CQ or QST will reveal descriptions of several vertical systems.

For the higher frequency bands Beams, Cubical Quads, and Rhombics will give the best results. The feed and matching systems vary considerably and one of the antenna handbooks should be consulted for more complete information.

The design centre of an antenna should be based on minimum SWR (standing wave ratio). The optimum, of course, would represent a ratio of 1 to 1 which means that all of the energy reaching the antenna is being radiated, with none reflected back to the transmitter.

Whatever the antenna type or design, a little research on the results to be expected from it and some experimentation at low power levels may prevent serious damage to your new transmitter. A reflected power meter will give an instantaneous reading of antenna efficiency.

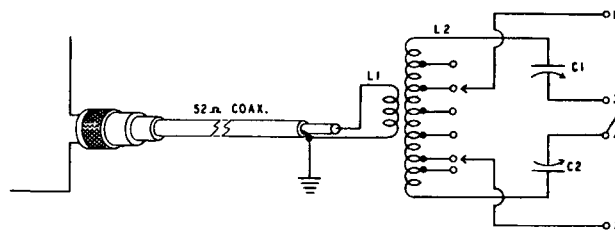

FIGURE-22.

When loading to either a balanced or an unbalanced system, the maximum loading point of 250 milliamperes in the final stage should not be exceeded. In many instances, the transmitter will load to a higher level, but the harmonic suppression of the pi network is better if the output coupling capacitor is not reduced to absolute minimum value. Then too, the extra 10 or 15 watts which would be gained by maximum loading would not make any appreciable difference at the receiving end of the transmission.

LOW PASS FILTERS: The harmonic rejection of the pi network output circuit of the DX-100U is excellent and will attenuate harmonics considerably when the transmitter is properly earthed and carefully tuned. However, additional harmonic attenuation may be had with the use of a low-pass filter between the output of the transmitter and the feed line or antenna. Such a filter should be designed to handle maximum power output of the transmitter and must be operated into its nominal impedance.

Needless to say, no attempt has been made here to cover the theory of antennas, as such, since much has been written on this subject. The possibilities in different antenna types and different feed systems are many and the factors mentioned herein only scratch the surface of the subject. Each operator will need to do his own investigation into the advantages and disadvantages of the various systems to determine just which one will best suit his needs. Basic data is available through the Radio Amateur Handbooks and other technical publications.

Some formulae that should prove helpful are listed as follows:-

$$1 \text{ wave length in space} = \frac{300,000 \text{ metres}}{F_{kc}}$$

$$\text{Centre fed dipole one-half wave long (length in feet)} = \frac{468}{F_{mc}}$$

$$\text{Folded dipole one-half wave long (length in feet)} = \frac{462}{F_{mc}}$$

$$\text{Zepp antenna one-half wave long (length in feet)} = \frac{492}{F_{mc}}$$

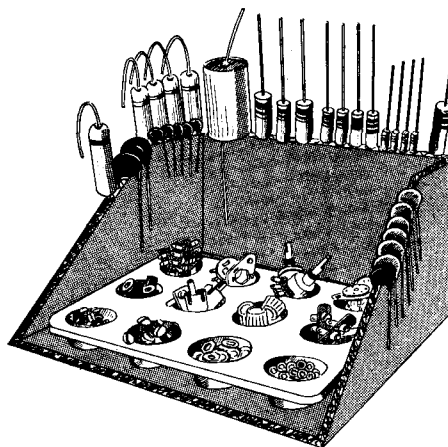

This illustration shows how resistors and capacitors may be placed in the cut edge of a corrugated cardboard carton until they are needed. Their values can be written on the cardboard next to each component.



REPLACEMENTS

Material supplied with Heathkits has been carefully selected to meet design requirements and ordinarily will fulfill its function without difficulty. Occasionally, however, improper instrument operation can be traced to a faulty valve or component. Should inspection reveal the necessity for replacement, write to Daystrom Ltd. and please supply all of the following information:-

- A. Thoroughly identify the part in question by using the part number and description found in the Manual parts list.
- B. Identify the type and model number of the kit in which it is used.
- C. Mention the order number and date of purchase.
- D. Describe the nature of defect or reason for requesting replacement.

Daystrom Ltd. will promptly supply the necessary replacements. Please do not return the original component until specifically requested to do so. Do not dismantle the component in question as this will void the guarantee. If valves are to be returned, pack them carefully to prevent breakage in shipment, as broken valves are not eligible for replacement. This replacement policy does not cover the free replacement of parts that may have been broken or damaged through carelessness on the part of the kit-builder.

SERVICE

If the completed instrument should fail to function properly and attempts to find and cure the trouble prove ineffective, the facilities of Daystrom's Service Dept. are at your disposal. Your instrument may be returned carriage paid to Daystrom Ltd., Gloucester, and the Company will advise you of the service charge where not covered within the terms of the guarantee (i.e. a faulty component supplied by us). **THIS SERVICE POLICY APPLIES ONLY TO COMPLETED INSTRUMENTS CONSTRUCTED IN ACCORDANCE WITH THE INSTRUCTIONS AS STATED IN THIS MANUAL.** Instruments that are modified in design will not be accepted for repair. Instruments showing evidence of acid core solder or paste fluxes will be returned not repaired.

Daystrom Ltd. is willing to offer its full co-operation to assist you in obtaining the specified performance level of your instrument. Factory repair service is available or you may contact the Engineering Consultation Department by mail. For information regarding possible modification of existing kits, it is suggested that you refer to any one or more of the many publications that are available on all phases of electronics. Although Daystrom Ltd. sincerely welcomes all comments and suggestions, it would be impossible to design, test, evaluate and assume responsibility for proposed circuit and layout changes for specific purposes. Therefore, such modifications must be made at the discretion of the kit builder according to information which will be much more readily available from some local source.

SHIPPING INSTRUCTIONS

Before returning a unit for service, be sure that all parts are securely mounted.

ATTACH A LABEL TO THE INSTRUMENT GIVING
NAME, ADDRESS AND TROUBLE EXPERIENCED.

Pack in a rugged container, preferably wood, using at least three inches of shredded newspaper, wood wool or plastic cushioning material on all sides. **DO NOT DESPATCH IN THE ORIGINAL KIT CARTON AS THIS CARTON IS NOT CONSIDERED ADEQUATE FOR SAFE SHIPMENT OF THE COMPLETED INSTRUMENT.** Note that a carrier cannot be held liable for damage in transit if packing, in HIS OPINION, is insufficient.

PRICES: All prices are subject to change without notice.

MODIFICATIONS TO SPECIFICATIONS: Daystrom Ltd. reserves the right to discontinue instruments and to change specifications at any time without incurring any obligation to incorporate new features in instruments previously sold.

* * * * *

The Heathkit builder is again strongly urged to follow step-by-step the instructions given in this Manual to ensure successful results. Daystrom Ltd. assumes no responsibility for any damages or injuries sustained in the assembly or handling of any of the parts of this kit or the completed instrument.

COLOUR CODE FOR FIXED RESISTORS - (B.S.1852-1952) COLOUR BAND MARKING

FIG1. (COLOURED BAND MARKING PREFERRED)

THIS EXAMPLE SHOWS
A GRADE I. RESISTANCE
OF $6,800 \Omega \pm 5\%$

BLUE (6)
GREY (8)
RED ($\times 10^2$)
GOLD ($\pm 5\%$)
(SALMON PINK (GRADE I.)
(THIS MAY BE GENERAL BODY COLOUR

FIG2. BODY, TIP & SPOT MARKING

FIG3. BODY TIP & CENTRAL BAND MARKING

**AMERICAN "RMA", "JAN" & COMMERCIAL CODING
FOR MOULDED MICA CAPACITORS**

CURRENT STANDARD CODE

WHITE (RMA)
BLACK (JAN)
CLASS
TOLERANCE

MOULDED FLAT CAPACITOR COMMERCIAL CODE

BLACK BODY
WORKING VOLTS
MULTIPLIER
2ND 1ST SIGNIFICANT FIGURE

JAN. CODE CAPACITOR

SILVER
1ST 2ND SIGNIFICANT FIGURE
MULTIPLIER
CHARACTERISTIC TOLERANCE

COLOUR CODE FOR RESISTORS AND CAPACITORS

Colour	Value in Ohms or pF for Cols. A, B & C.				COL. D. (TOLERANCE RATING)			CAPACITORS COL. E. TEMP. COEFFICIENT per 10^6 per °C.
	COL. A. 1st Figure	COL. B. 2nd Figure	COL. C. (MULTIPLIER)		Resistors	Ceramic Capacitors		
			Resistors ohms	Capacitors pF		Up to 10 pF	Over 10 pF	
BLACK	-	0	1	1	-	2 pF	+ 20%	0
BROWN	1	1	10	10	+ 1%	0.1 pF	+ 1%	-30
RED	2	2	100	100	+ 2%	-	+ 2%	-80
ORANGE	3	3	1,000	1,000	-	-	+ 2.5%	-150
YELLOW	4	4	10,000	10,000	-	-	-	-220
GREEN	5	5	100,000	-	-	0.5 pF	+ 5%	-330
BLUE	6	6	1,000,000	-	-	-	-	-470
VIOLET	7	7	10,000,000	-	-	-	-	-750
GREY	8	8	100,000,000	.01	-	0.25 pF	-	+30
WHITE	9	9	1,000,000,000	.1	-	1 pF	+ 10%	+100
SILVER			.01	-	+ 10%	-	-	
GOLD			.1	-	+ 5%	-	-	
SALMON								
PINK								
NO "D"								

COLOUR
The Colour coding should be read from left to right, in order, starting from the end and finishing near the middle.

Standard \pm tolerances for resistors are:- Wire-wound: 1%, 2%, 5%, 10%. Composition, Grade 1: 1%, 2%, 5%. Grade 2: 5%, 10%, 20%. (20% is indicated by 4th (or 'D') colour). Grade 1: ("high-stability") composition resistors are distinguished by a salmon-pink fifth ring or body colour. (Reference: B.S. 1852: 1952 B.S.I.).
N.B. High-Stability Resistors supplied with this kit are not as a rule colour coded but enamelled in one colour on which the value in Ohms is printed in figures. Capacitors supplied in this kit usually have their capacity clearly marked in figures. Some Capacitors coded as above also have additional "voltage rating" coding.

