



Johnson
electronic equipment

OPERATING MANUAL

**VIKING
INVADER 2000
TRANSMITTER**



E. F. Johnson Company

W A S E C A , M I N N E S O T A

VIKING INVADER AND INVADER 2000

MODIFICATION SHEET

Invader Power Supply Schematic Diagram

1. Add a 1000 ohm resistor, R180, in series with the lead from pin 6 of the 5U4 tube to pin 7 of the 6X4 tube.
2. Change R175, 176, 177 each to 20,000 ohm 10 watt resistors.

Parts List

Page 1, Change C20 to read C20, 147, 148 and change quantity to 3

Delete 22.1712 C65

Delete 22.1754 C144 15 N 220 \pm 5% ceramic capacitor

Add 22.4033-5 C144 22 mmf \pm 5% Durmica capacitor

Page 2, Delete 22.1508 C141 quantity 1 680 mmf \pm 10% 1500V mica capacitor

Add 22.859 C141 A, B quantity 2 300 mmf \pm 5% 500V mica capacitor

Page 5, Add 22.6021-10, R38, quantity 1, 68 ohm \pm 10% 1 watt resistor

Delete R39 at 22.5051-10 and change quantity from 2 to 1

Delete R40 at 22.5105-10 and change quantity from 3 to 2

Add 22.7069-10 R40 quantity 1 6800 ohm \pm 10% 2 W. resistor

Page 6, At 22.837 delete TS20 and change quantity from 5 to 4

At 22.1401-1 add TS20 and change quantity from 2 to 3.

Add 22.1978 T6 Transformer, 6.3 VAC

Page 9, Delete 22.5067-10 R207 quantity 1 resistor 5600 ohm \pm 10% 1/2 watt

Add R207 to 22.5083-10 and change quantity from 2 to 3

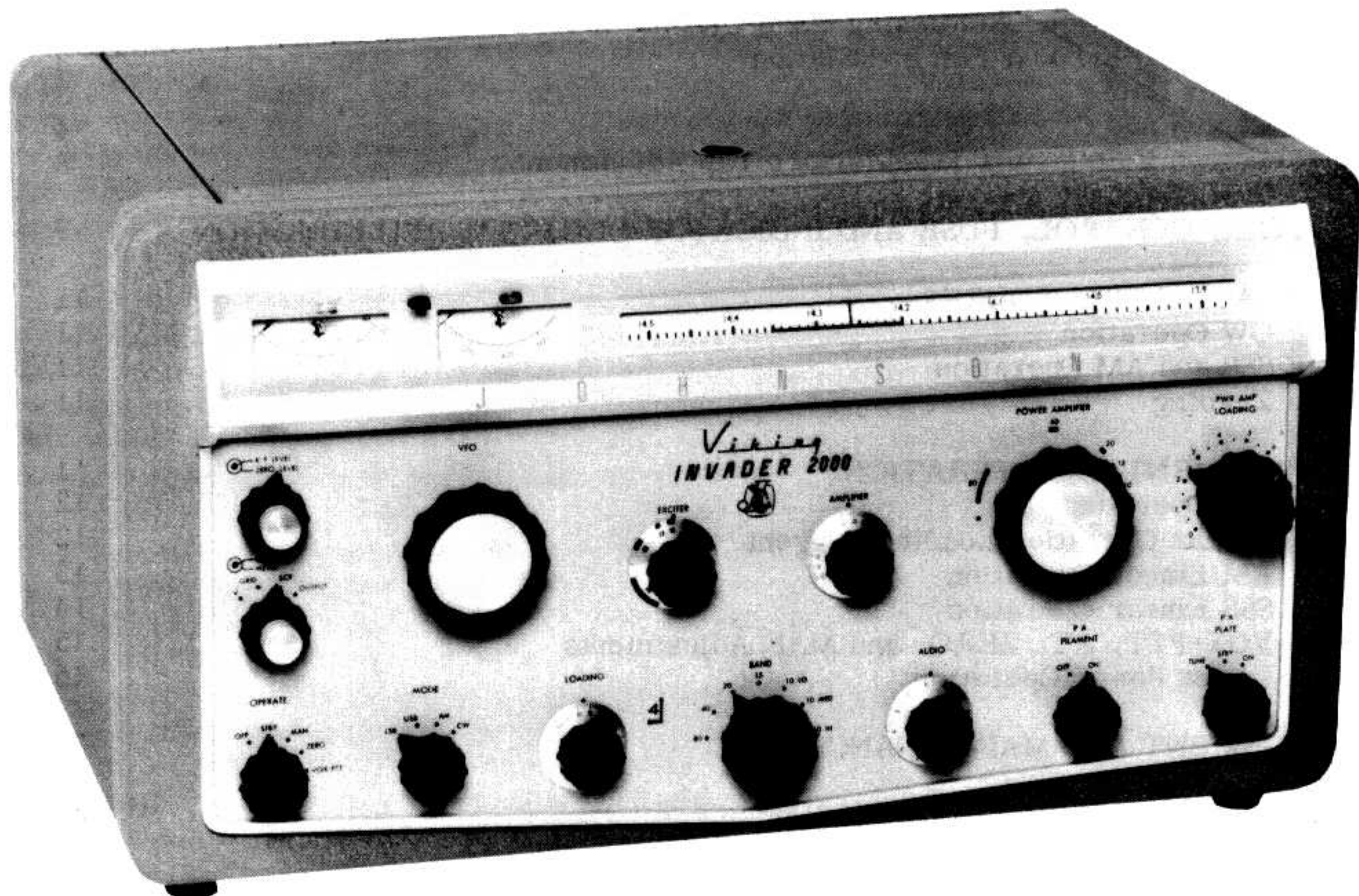

JOHNSON VIKING INVADER 2000

OPERATING MANUAL CONTENTS

	<u>Page</u>
A. DESCRIPTION AND SPECIFICATIONS	1
1. Electrical Description	1
2. Mechanical Description	1
3. Specifications	1
4. Invader Block Diagram	
B. INSTALLATION	3
1. Unpacking and Inspection	3
2. Transportation and Missing Parts Claims	3
3. Tube and Exhaust Fan Installation	3
4. Power Cable	3
5. Cables and Ground Connection	4
6. Screen Voltage and Transformer Tap Adjustment	8
C. METER, CONTROL, FUSE AND INDICATOR LOCATION AND FUNCTION	9
D. OPERATING PROCEDURES	11
1. CW Operation	11
2. SSB and AM Operation	11
3. Zeroing	11
E. ADJUSTMENT AND OPERATION	11
1. CW Operation	12
2. Linear Operation Loading Current	12
3. AM Linear Operation	13
4. SSB Linear Operation	14
5. VOX-PTT, AT, ZERO, and MAN Adjustments	15
6. Lower Power Operation	16
F. ALIGNMENT AND MAINTENANCE	17
G. CONVERSION FROM 230 TO 115 VAC	24

PARTS LIST

ILLUSTRATIONS

Figure A	Approximate Amplifier Operating Values
Figure B	Approximate Dial Positions
Figure C	Front Panel Outline
Figure D	Rear Chassis Outline
Figure 1	Cabinet - Rear View
Figure 2	RF Unit - Top View
Figure 3	RF Unit - Bottom View
Figure 4	Invader Power Supply - Bottom View
Figure 5	Dial and Meter Area View
Figure 6	Left Rear Corner - Bottom View
Figure 7	Exciter 6146 Grid and Loading View
Figure 8	Operate and Mode Switch View
Figure 9	Power Supply - Top View
Figure 10	Power Supply - Bottom View
Figure 11A	Power Amplifier - Bottom View
Figure 11B	Power Supply - Rear View
	Invader Voltage Measurements
	Amplifier and Power Supply Schematic Diagram
	Invader Power Supply Schematic Diagram
	Invader Schematic Diagram

VIKING INVADER 2000 OPERATING MANUAL

A. DESCRIPTION AND SPECIFICATIONS

1. Electrical Description

The Invader 2000 is a filter type transmitter capable of SSB, AM, and CW operation on all amateur bands between 3.5 and 30 megacycles. The equipment is designed for maximum power inputs of 2000 watts PEP in AB₂ linear SSB, 800 watts in linear AM and 1000 watts in CW operation. The exciter may be operated alone with power inputs of 200 watts PEP in SSB, 90 watts in AM and 200 watts in CW.

The exciter utilizes a highly stable crystal filter with an unusually sharp response for excellent carrier and unwanted sideband suppression. RF controlled ALC and audio AGC circuits provide greater speech power and provision is made for plugging a phone patch directly into the audio input. Mixer type keying is used for shaped characters free from clicks and chirps. The exciter output circuit is a wide range Pi network for loading into an antenna and also provides integral fixed loading for loading into the high power amplifier grid.

The high power amplifier employs two parallel PL175A tubes with a 200 ohm resistive grid circuit and a wide range Pi network output circuit. The resistive grid eliminates a tuned grid circuit and neutralization and loads the exciter for proper operation. TVI suppression, spurious filtering, parasitic oscillation suppression and rigorous shielding are designed into the equipment.

The Invader 2000 power supply furnishes all plate, screen and bias voltage requirements. The exciter bias and screen voltage are tube regulated as is the amplifier bias on SSB and AM. The amplifier screen voltage is dynamically regulated by the transformer design, large bleeder current and large filter capacity. Both the exciter and amplifier high voltage supplies have swinging choke input and large filter capacitors for improved regulation. The power supply is wired for 230 VAC input power although it may be converted for a 115 VAC source.

2. Mechanical Description

The Invader 2000 RF equipment is installed in a desk-top cabinet with a hinged top for easy access to the interior. In addition to the cabinet shielding, both the exciter amplifier and high power amplifier are enclosed in individual shielded compartments for TVI and spurious radiation suppression. The PL175A filament leads and the rotary tank inductor are cooled by a fan mounted in the amplifier chassis. An exterior mounted exhaust fan on the rear of the cabinet provides more than adequate cooling for both the exciter and amplifier.

All the Invader 2000 power supplies are installed in a single protected enclosure. Voltage and control cables are furnished for remote location of the power supplies from the RF equipment. All primary voltages are fuses and a high voltage shorting switch is activated whenever the top perforated cover is removed. The perforated top and bottom covers, as well as properly located holes in the chassis, provide adequate ventilation for the power supply components.

3. Specifications

Frequency Coverage	3.5--4.1 mcs.	28.0--28.6 mcs.
	7.0--7.6 mcs.	28.5--29.1 mcs.
	13.9--14.5 mcs.	29.1--29.7 mcs.
	20.9--21.5 mcs.	

A. 3.	Emission	<ol style="list-style-type: none"> 1. Continuous wave 2. Linear AM (single sideband plus carrier) 3. Single side band, suppressed carrier 																					
	Suppression	<ol style="list-style-type: none"> 1. Unwanted side band, 60 db or better 2. Carrier, 55 db 3. Spurious, 55 db or better 																					
	Distortion Products	<ol style="list-style-type: none"> 1. Exciter, 35 db or better down 2. Amplifier, 30 db or better down 																					
	VFO stability	Better than 75 cycles after warmup																					
	RF Power	<table border="0" style="width: 100%;"> <tr> <td style="vertical-align: top;">Exciter</td> <td style="padding-left: 20px;">SSB</td> <td>200 watts PEP input</td> </tr> <tr> <td></td> <td style="padding-left: 20px;">CW</td> <td>200 watts input</td> </tr> <tr> <td></td> <td style="padding-left: 20px;">AM</td> <td>25-30 watts output</td> </tr> <tr> <td colspan="3"> </td> </tr> <tr> <td style="vertical-align: top;">Amplifier</td> <td style="padding-left: 20px;">SSB</td> <td>2000 watts PEP input</td> </tr> <tr> <td></td> <td style="padding-left: 20px;">CW</td> <td>1000 watts input</td> </tr> <tr> <td></td> <td style="padding-left: 20px;">AM</td> <td>250-300 watts output</td> </tr> </table>	Exciter	SSB	200 watts PEP input		CW	200 watts input		AM	25-30 watts output				Amplifier	SSB	2000 watts PEP input		CW	1000 watts input		AM	250-300 watts output
Exciter	SSB	200 watts PEP input																					
	CW	200 watts input																					
	AM	25-30 watts output																					
Amplifier	SSB	2000 watts PEP input																					
	CW	1000 watts input																					
	AM	250-300 watts output																					
	RF Output Impedance	40 to 600 ohms, adjustable Pi network																					
	Primary Voltage Source	230 volt, 3 wire, 50/60 cycles, single phase, grounded neutral OR 115 volt, 2 wire, 50/60 cycles, single phase																					
	Primary Power Demand	Exciter only, standby 130 watts Exciter only, max. load 325 watts Exciter and amplifier, standby 450 watts Exciter and amplifier, 1KW CW 1650 watts Exciter and amplifier, AM 1400 watts Exciter and amplifier, Two tone 1775 watts Exciter and amplifier, SSB voice 1475 watts																					
	Dimensions	Transmitter 11 5/8" high, 21" wide, 17 1/2" deep. Power supply 11 1/4" high, 19 3/4" wide, 14 1/2" deep.																					
	Weights	Transmitter 53 lbs. Power supply 102 lbs.																					

B. INSTALLATION

1. Unpacking and Inspection

The Invader 2000 transmitter is shipped in three boxes--box 1 contains the RF unit--box 2 contains the power supplies--box 3 contains the two PL175A tubes, control cables and exhaust fan. Inspect all packages for damage due to mishandling or abuse during shipment.

Remove the RF unit from its cabinet by unscrewing the two tie rods, 10 screws, and 3 knobs located at the rear of the cabinet. Remove the cover from the power supply by unscrewing the 6 screws located at the front and rear of the cover. Remove all the packing from around the tubes and the transformers. Inspect the contents of the 3 packages for damage to components, cabinets, tubes etc. and for missing parts.

Connect the two plate transformer leads to the 866 rectifier terminals and reinstall the cover using the 6 screws.

2. Transportation and Missing or Damaged Parts Claims

Report all claims for transportation damage immediately to the carrier and not to the E. F. JOHNSON COMPANY.

Report any missing parts immediately to the distributor from whom the equipment was purchased.

3. Tube and Exhaust Fan Installation

All tubes, except the two PL175A's are shipped installed in the equipment. The two PL175A's are installed as follows:

- a. Remove the perforated cover from the amplifier shield.
- b. Insert the two PL175A tubes in the sockets.
- c. Loosen the radiator plate cap top screws and setscrews on each plate suppressor. Install the suppressors with the radiator caps on the tube plate terminals and securely bolt the other ends to the screw terminal on the plate blocking capacitor strap (Figure 2) using the internal tooth lockwasher and hex nut. Orient each radiator cap so the setscrew is toward the front of the unit and tighten both top screws and both setscrews securely.
- d. Replace the perforated cover on the amplifier shield.
- e. Install the exhaust fan assembly over the hole at the rear of the cabinet with the fan power plug at the bottom. Use the four binding head 6-32 screws shipped with the fan for mounting the fan assembly on the outside of the cabinet. The four screws should be threaded from the inside of the cabinet into the tapped holes on the fan assembly mounting brackets.
- f. Replace the Invader 2000 in the cabinet and install the 10 screws, 3 knobs and 2 tie rods.

4. Power Cable

All Invader 2000 transmitters are shipped wired and tested for operation from a 3 wire, single phase 230 to 250 volt 50/60 cycle power source with a grounded neutral. It is preferable to operate the equipment from this type power source

- B. 4. The power plug for the power supply is furnished with the equipment and the purchaser must secure the required length of cable and connector to the power source. The three wire cables should be Underwriter Laboratory approved with a current rating of 15 amperes. The grounded neutral wire must be connected to the wide contact of power plug P301. The two other cable wires should each connect to a narrow contact on plug P301, as follows:

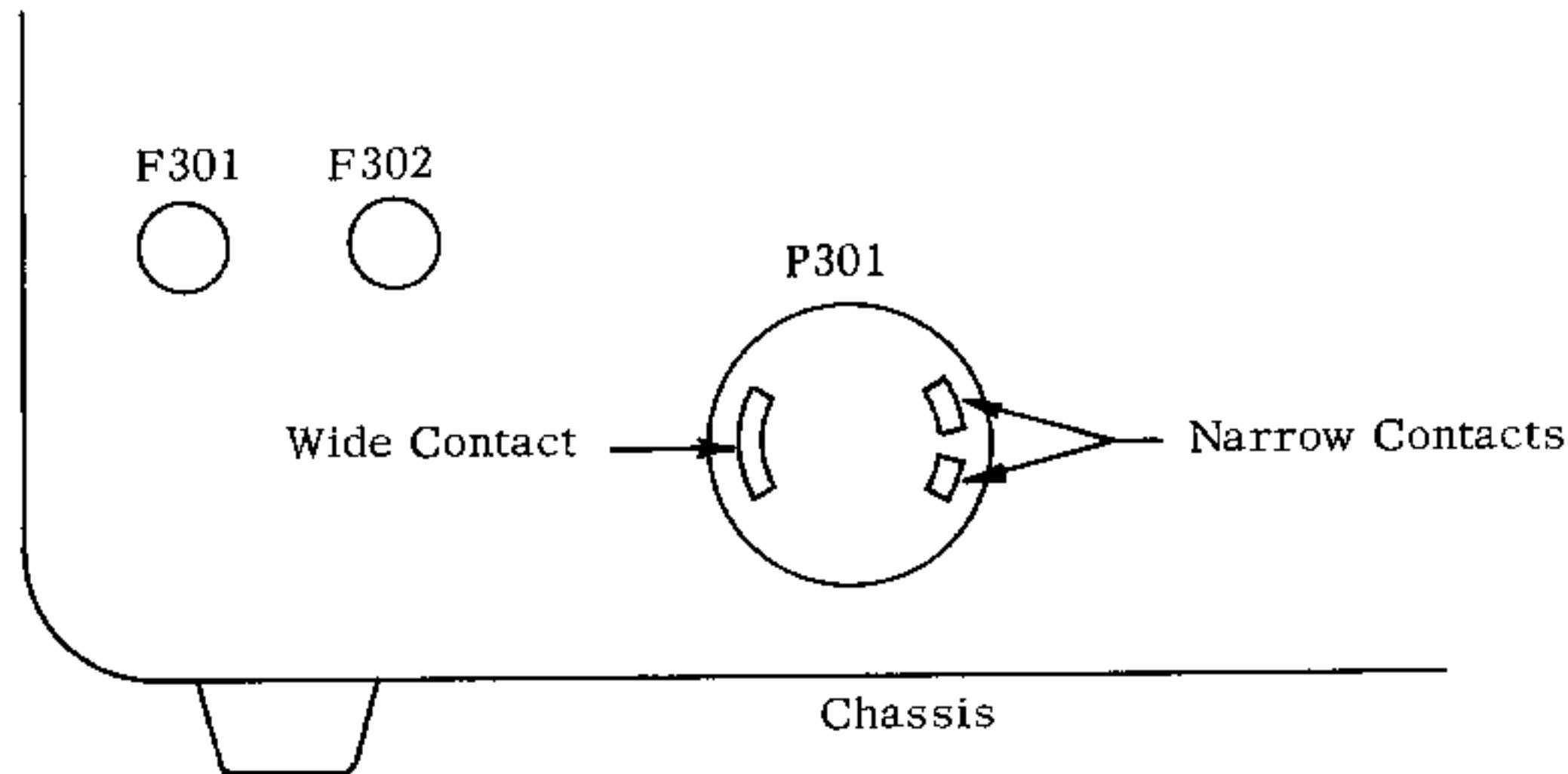

If the equipment is to be operated from a two wire single phase 115 volt 50/60 cycle source, the power input circuit and cable must be converted as described in Section G.

5. Cables and Ground Connections

- a. Exciter power plug (P101) polarity.

If the 866A and PL175A tube filaments fail to light when the OPERATE switch is placed in the STBY position (PA FILAMENT switch at ON, PA PLATE switch at STBY) the polarity of the exciter power supply plug, P101, should be reversed in the power receptacle J302. The plug is shown at the lower right of the power supply on Figure 9.

- b. Invader 2000 interconnection and accessories cables.

Connect the two interconnecting power and control cables as shown in the sketch on the next page. Avoid excessive lengths of the coaxial transmission lines which should be of 50 ohm impedance (RG8/U).

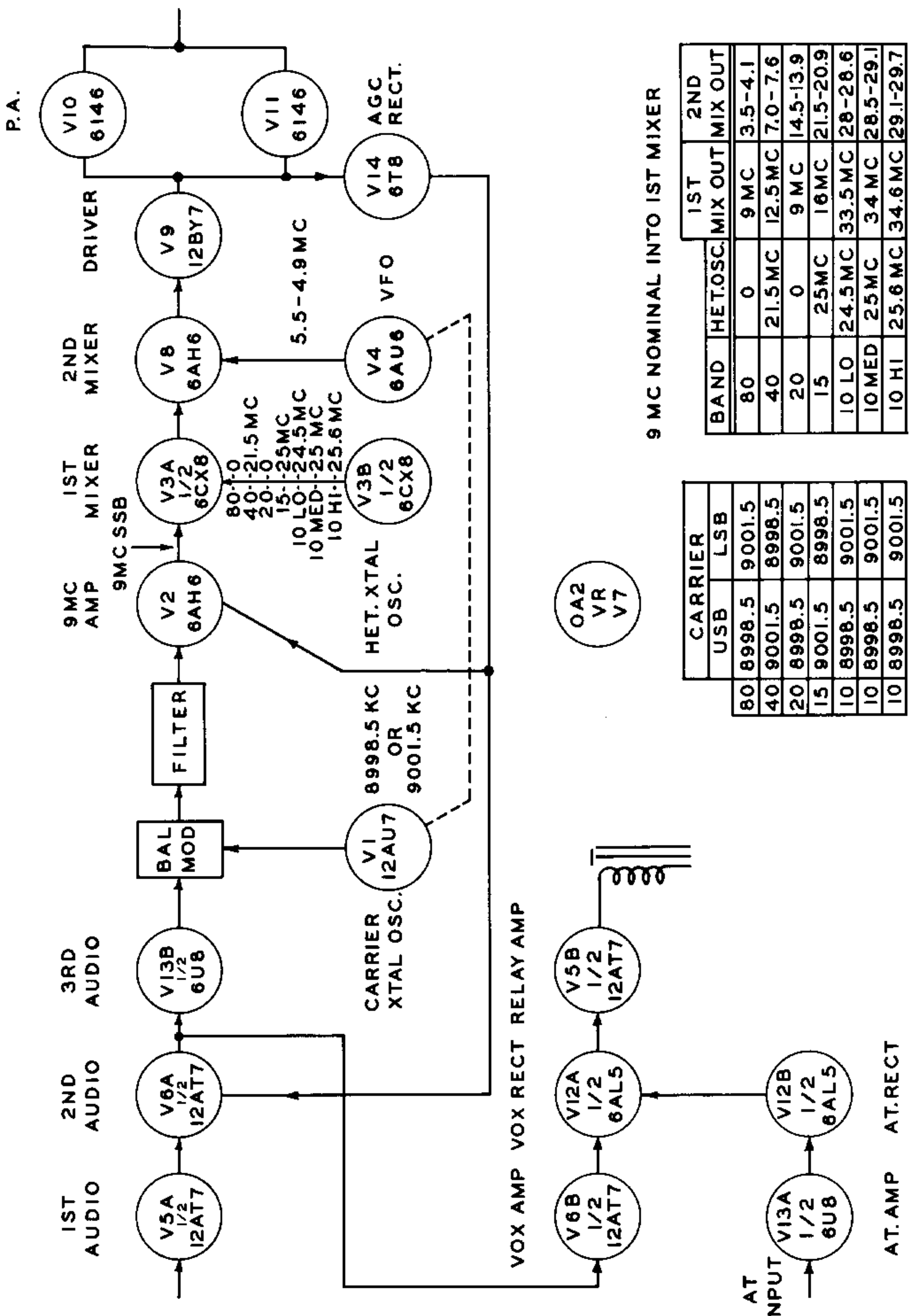

9 MC NOMINAL INTO 1ST MIXER

BAND	HET. OSC.	1ST MIX OUT	2ND MIX OUT
80	0	9 MC	3.5-4.1
40	21.5 MC	12.5 MC	7.0-7.6
20	0	9 MC	14.5-13.9
15	25 MC	16 MC	21.5-20.9
10 LO	24.5 MC	33.5 MC	28-28.6
10 MED	25 MC	34 MC	28.5-29.1
10 HI	25.6 MC	34.6 MC	29.1-29.7

CARRIER	LSB	
	USB	LSB
80	8998.5	9001.5
40	9001.5	8998.5
20	8998.5	9001.5
15	9001.5	8998.5
10	8998.5	9001.5
10	8998.5	9001.5
10	8998.5	9001.5

INVADER BLOCK DIAGRAM AND FREQUENCY SCHEME

INVADER 2000 CABLE CONNECTIONS

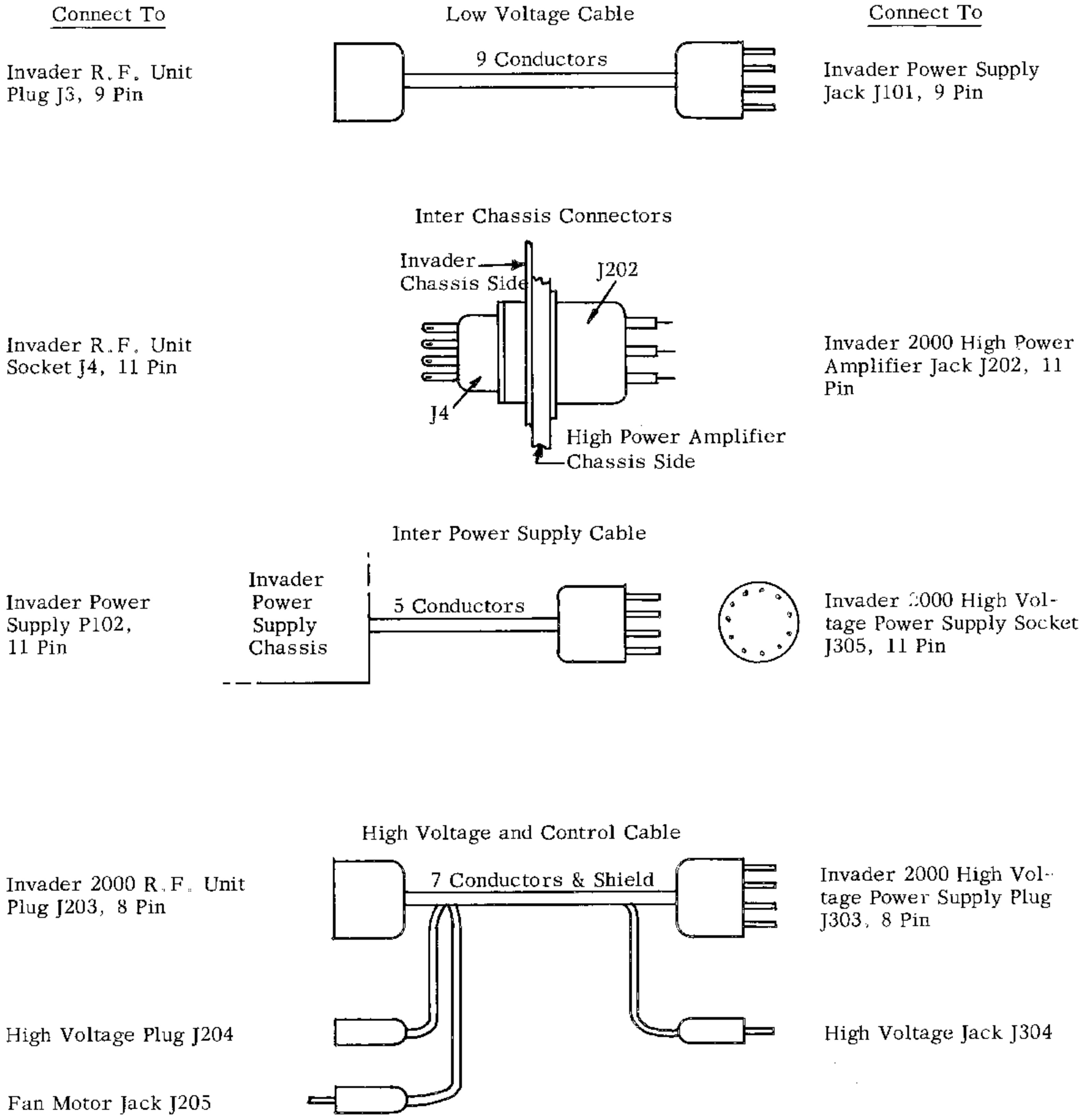

The above figures show the cables connecting the R. F. UNIT and the POWER SUPPLY UNIT and will be of assistance in tracing circuits between the schematic diagrams.

PHONE PATCH CONN

Johnson Phone Patch
250-96 plugs into J6
and microphone plugs
into patch.

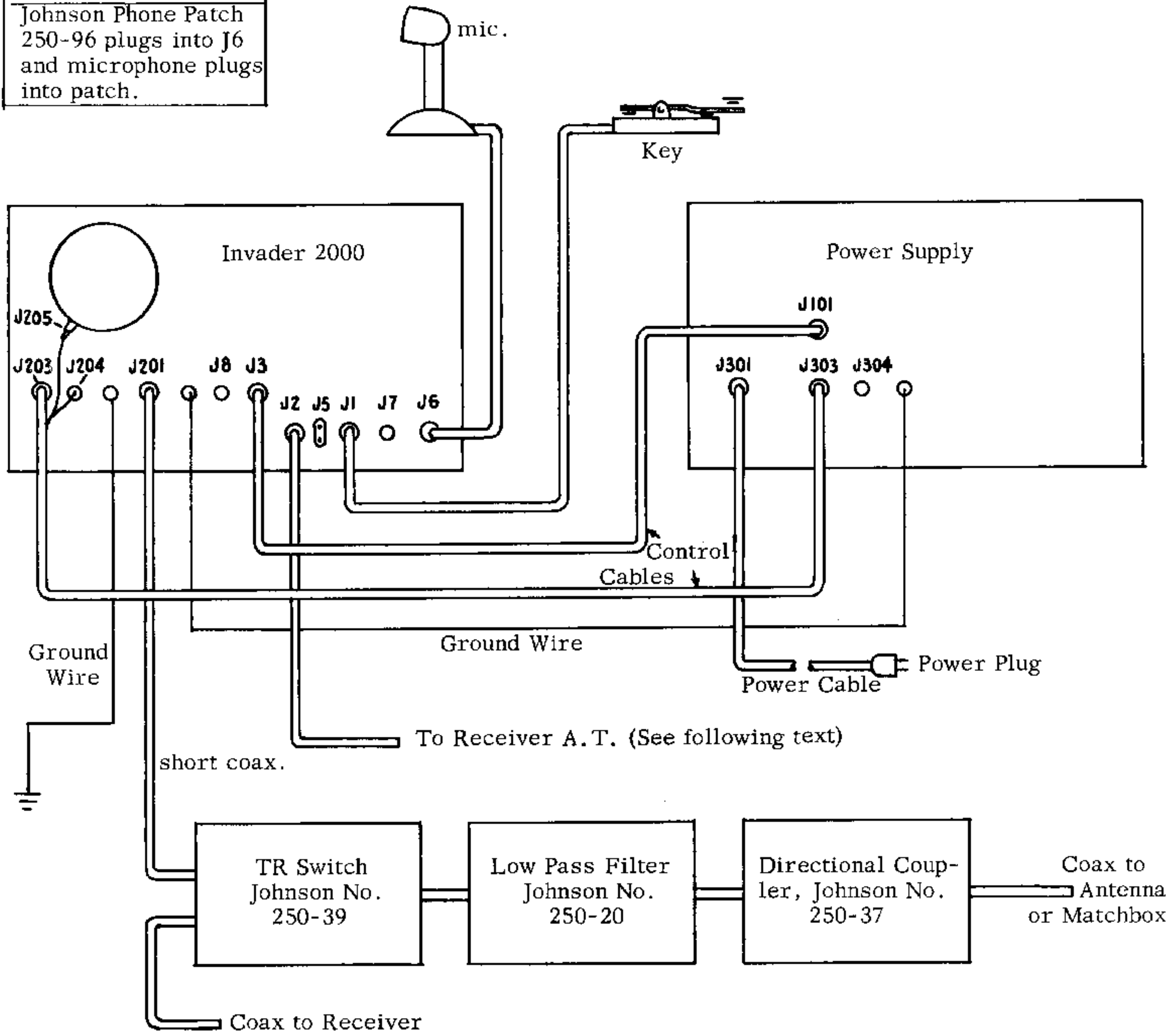

Ground wires--no. 12 gauge or larger copper
Coaxial lines--RG8/U 50 impedance

The coaxial line between the transmitter and the TR switch should be as short as possible--not more than 12"

If it is desirable to alternately operate the exciter or final amplifier into an antenna, (200 watts or 2000 watts power) the above circuit can be modified as shown on the next page.

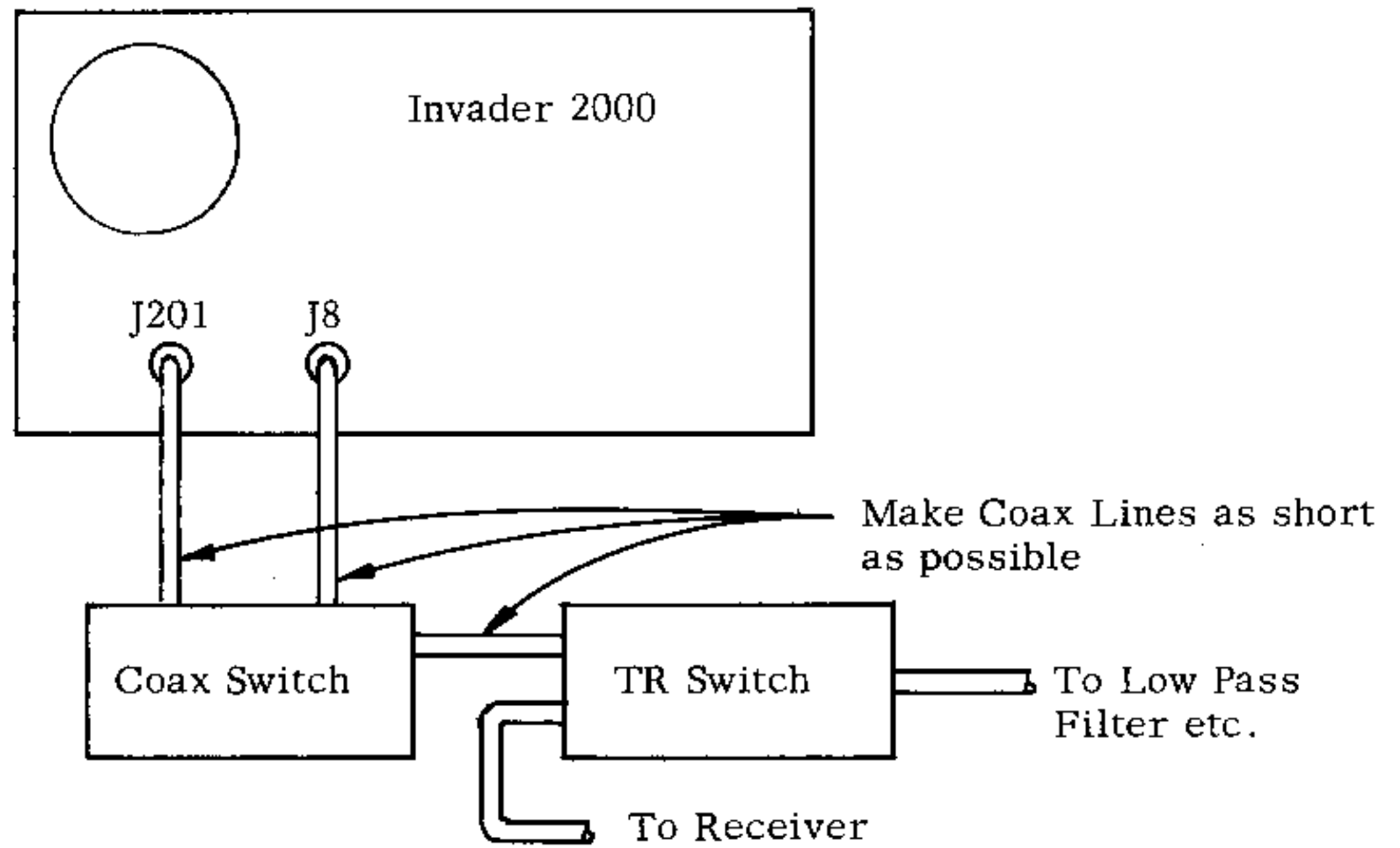

J8 - Exciter Output

J201 - High Power Amplifier Output

- B. 5. The ground wire from the Invader 2000 to the ground should be as short as possible avoiding lengths which are a quarter wavelength long on any of the operating frequencies. If the ground wire must be long, it is desirable to make its length a 1/2 or full wavelength long on the operating frequencies. In some installations, it may be advisable to install more than one ground wire of different lengths.

c. Anti-trip circuit external connections

The anti-trip connections to the receiver are secured at jack, J2, located at the rear of the Invader 2000 chassis. The connections can be made using the 5 pin plug and a cable as shown in the examples below:

TYPICAL RECEIVER CONNECTIONS (Also 75A1 and early 75A2 receivers)

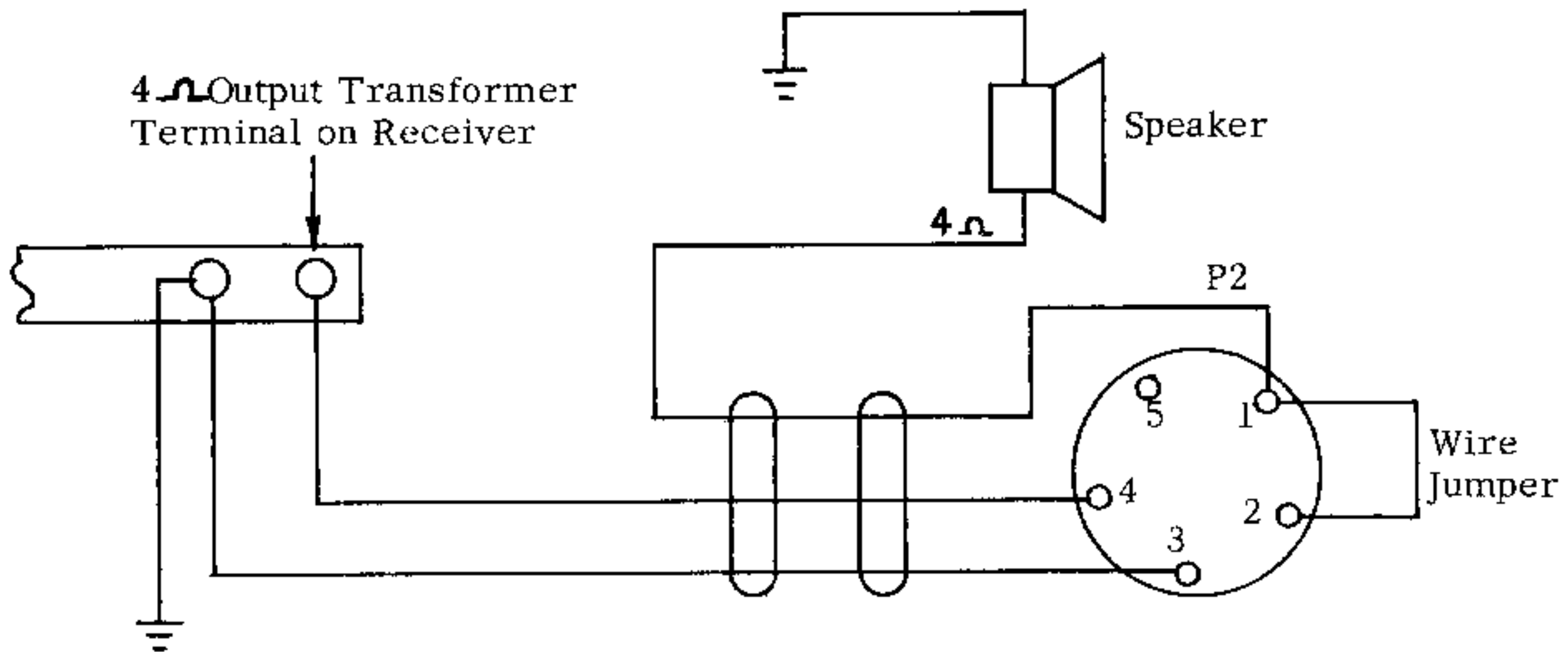

COLLINS 75A2, 3, 4 RECEIVER CONNECTIONS

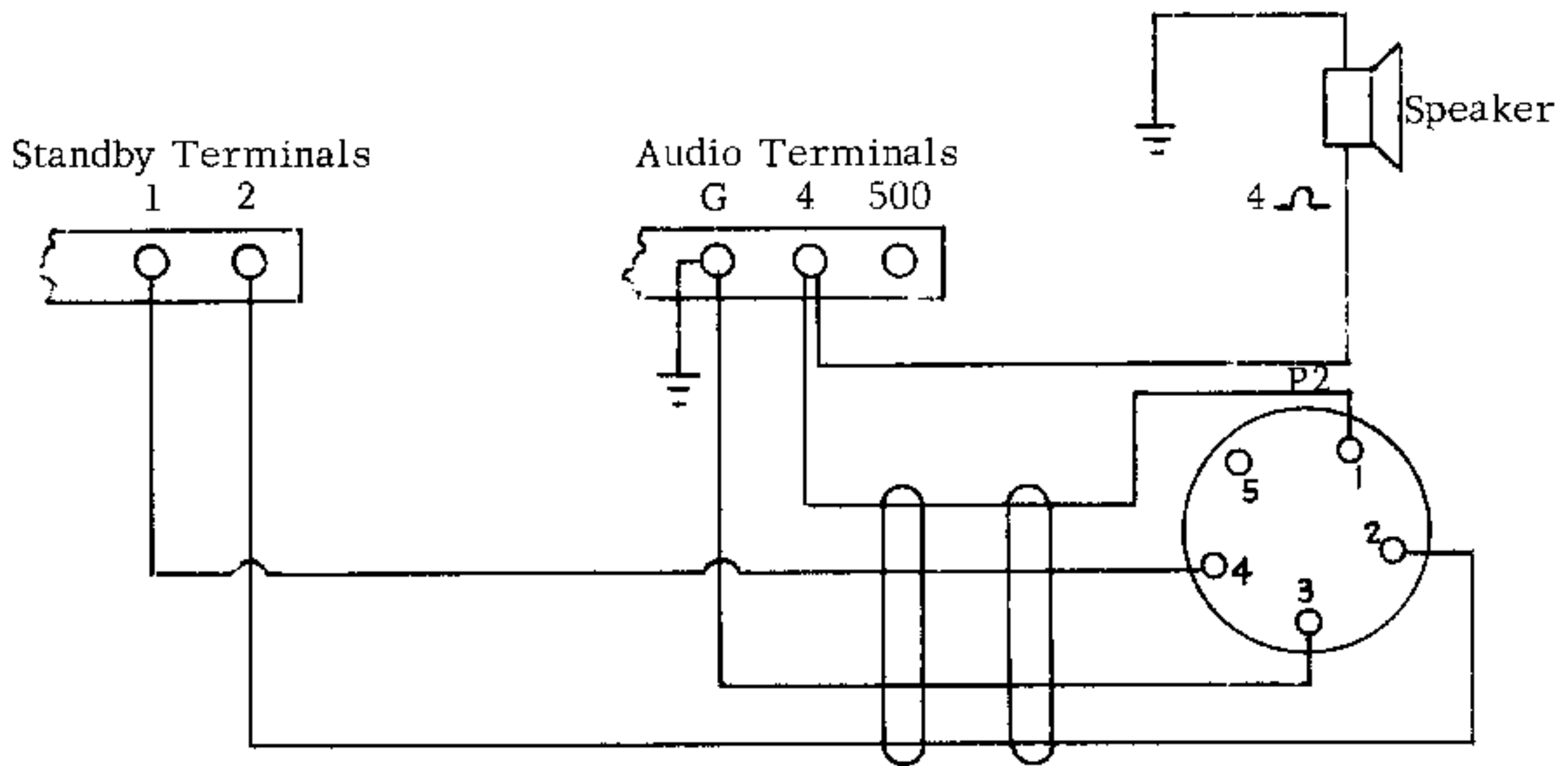

- B. 5. The internal connections to jack (J2) are shown below. If neither of the two above anti-trip circuits are used, the SPDT relay contacts terminating in pins 2, 4 and 5 of jack (J2) may be used in other anti-trip circuits or other low current and voltage circuits. One example is to use pins 4 and 5 to apply blocking bias on the receiver AVC during the transmitting period.

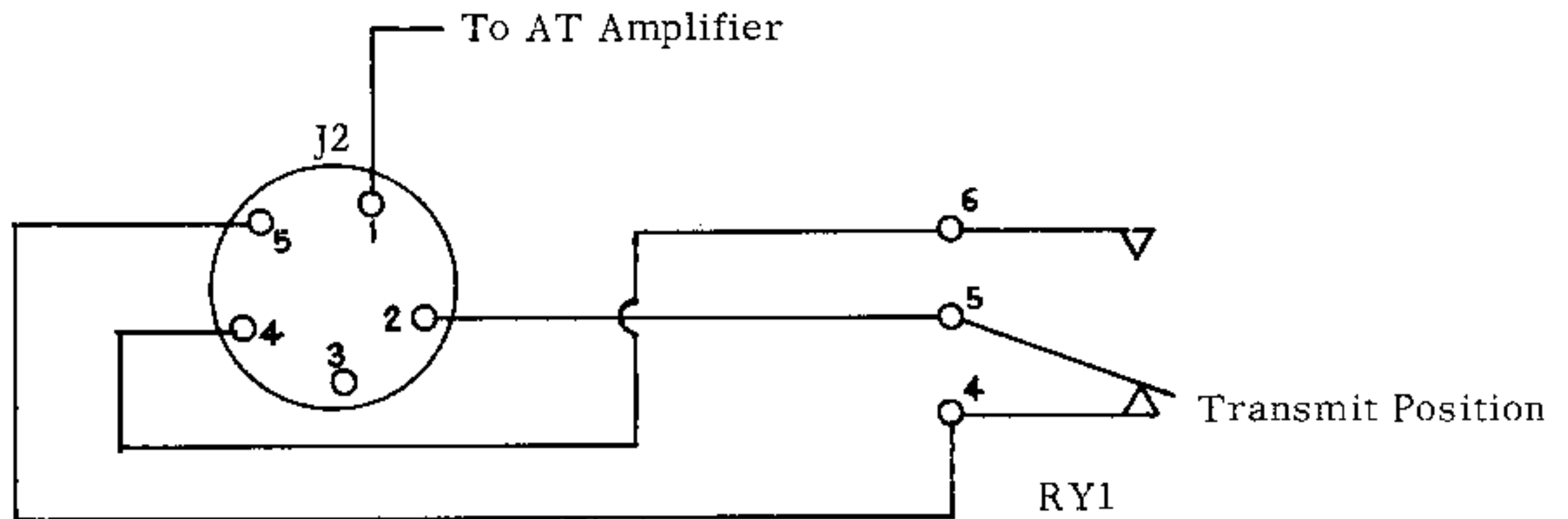

- d. PTT jack J7 connections

No connections are needed to this jack unless the exciter is used with a Viking Audio Amplifier and Viking Kilowatt transmitter.

- e. TR switch and antenna relay

The Invader 2000 can be used with a TR switch, an antenna relay or separate transmitter and receiver antennas. The interconnection diagram (Section b) shows the connections when a TR switch is used. When an antenna relay is used, the diagram should be modified as shown on the next page. Jack (J5) provides 115 VAC for operation of the antenna relay. The relay will have to be a fast operate type to be used on Voice Operate operation. An antenna relay can not be used in CW break-in operation.

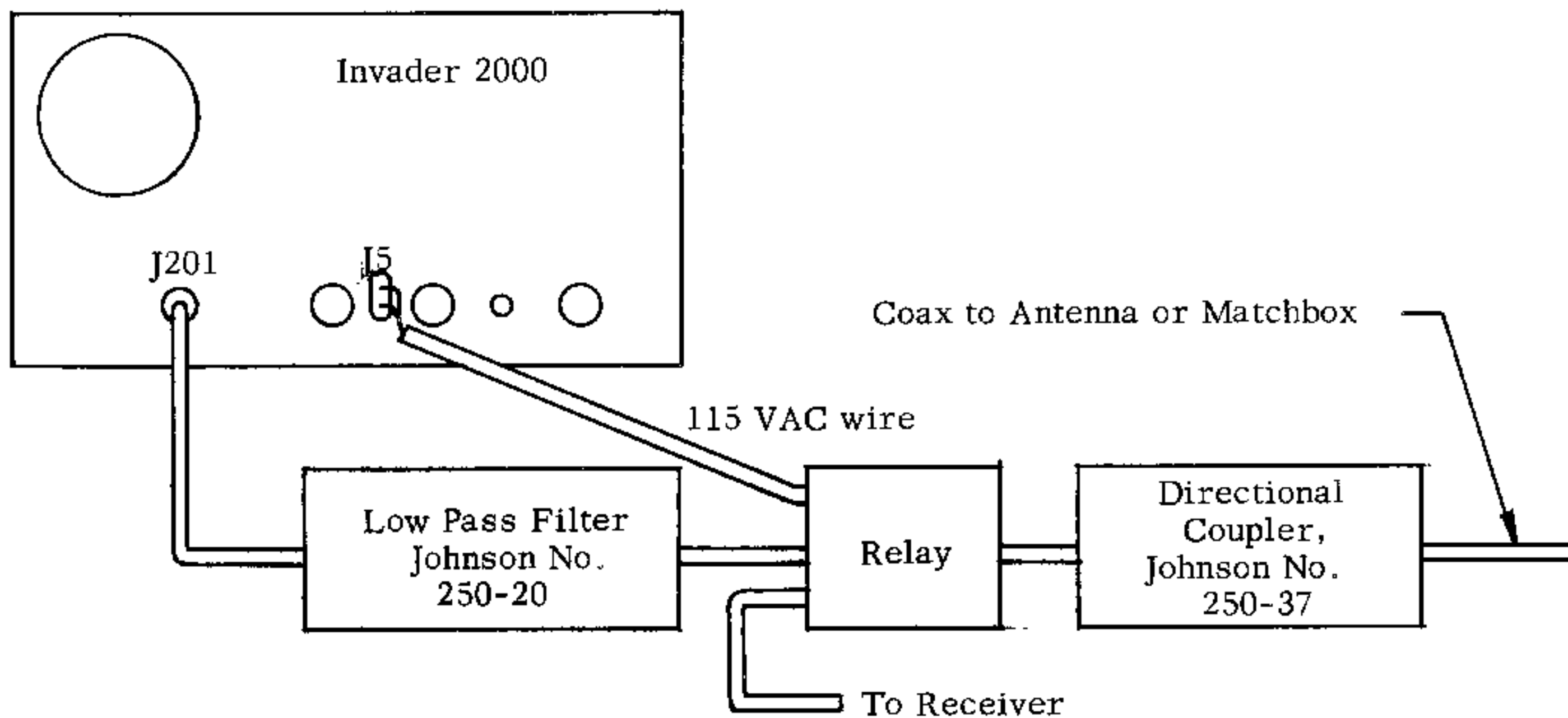

The TR switch (such as the JOHNSON TR switch no. 250-39) provides instantaneous high-efficiency electronic antenna switching. It can be used when operating in SSB, AM and CW modes.

B. 6. Screen Voltage Transformer Tap Adjustment.

The screen voltage transformer is wired at the factory for a primary voltage of 115-125 AC. At this primary voltage, the output of the screen supply should be approximately 500 to 530 volts d.c.

If the primary power line measures less than 115 VAC, the 250 ohm resistor R313 (located near XV303 in Figure 10) should be shorted out. If the screen voltage needs to be further increased, the tap on the transformer primary should be changed. The transformer taps are located at the bottom of the power supply chassis and are attached to terminal strip TS304 as shown in Figure 10. For the 115-125 VAC primary, the BLACK-YELLOW lead should be attached to terminal 2 and the BLACK-RED lead should be attached to terminal 1 of TS304. The two wires should be reversed for primary voltages of 114 VAC or less.

With the proper transformer primary tap connected (as discussed above) the screen voltage should be approximately 500 to 530 volts with no screen current being drawn. This voltage can be checked as follows:

- a. Remove the two fuses F301 and F302 (rear of power supply chassis, Figure 11B).
- b. Remove the plug (P102) from the 11 pin socket (J305) located on the top of the power supply chassis as shown in Figure 9.
- c. Place the PA PLATE control at ON and turn the transmitter on. (No final plate voltage will come on as the fuses have been removed.)
- d. Measure the screen voltage at pin 7 of J305. (Figure 10).

C METER, CONTROL, FUSE AND INDICATOR LOCATION AND FUNCTION

Before attempting to adjust the transmitter, the operator must familiarize himself with the location and function of the controls and meters. The familiarization charts in Figures C and D should be studied along with the descriptions given below

The location of other components such as resistors, capacitors etc., are shown in the photographic illustrations at the end of this manual.

1. MULTI METER (M1) indicates the amplifier plate voltage, amplifier grid and screen current and the exciter output as selected by the METER switch. The top scale reads the grid current directly and the plate voltage when the scale is multiplied by 100. The bottom scale reads the screen current directly and is used as an indicator of the exciter output.
2. METER (M2) indicates the amplifier plate current directly. This meter has a 0.25 second time constant for measurement of input power in SSB operation as well as AM and CW.
3. The OPERATE switch (SW2) selects the various voltages and circuits to place the exciter in OFF, STBY, MANUAL, ZERO, and VOX-PTT conditions of operation. This control also switches the power amplifier filaments and the high voltage contactor in conjunction with the PA FILAMENT and PA PLATE controls. The OFF position turns the primary power to all transformers off. The STBY position places blocking bias on the exciter driver and final and opens the high power amplifier plate contactor. The MAN position is used for manual control of the transmitter for SSB, AM and CW operation and is the only position to be used for CW. The ZERO position turns on the exciter and places a cut off bias on the exciter final so it does not operate. The VOX-PTT position switches the necessary circuits to permit VOX and PTT operation.
4. The MODE switch (SW3) selects the proper circuits and voltage for LOWER SIDE BAND, UPPER SIDE BAND, AM, or CW operation. In the LSB and USB positions, the proper carrier crystal oscillator is selected to give the desired sideband. The switch selects the proper carrier injection in the AM and CW positions and activates the keying circuit in CW.
5. The LOADING control rotates the variable loading capacitor (C107) and turns the fixed loading capacitor switch (SW4) when the exciter is loading into an antenna or external amplifier. Loading is increased with clockwise rotation. The control should be placed in the AMP position when driving the Invader 2000 amplifier. The LOADING dial is rotated more than 180° to switch the fixed capacitors. A slight resistance to rotation will be felt as the dial turns the fixed capacitor switch and then the dial will be free for another 180° rotation of the loading variable capacitor. The fixed capacitor switch positions are shown in the panel opening and are numbered from 1 through 9. The extreme clockwise position is the AMP position.
6. The BAND switch selects the proper capacitor, inductor and crystal for each frequency band. It also selects the proper fixed load coupling on the exciter amplifier when it is driving the Invader power amplifier.
7. The AUDIO dial adjusts the audio gain potentiometer (R43) with the gain increasing with clockwise rotation.
8. The PA FILAMENT switch (SW201) controls the primary voltage to the 866 filament transformer, PL175A filament transformer, screen voltage supply and the plate transformer contactor. The switch should always be placed in the ON position 15 to 30 seconds before the high voltage is turned on. When operating at 200 watt level (exciter only), the filaments may be turned off

- C.
9. The PA PLATE control (SW202) switches the high voltage transformer contactor OFF in the STBY position and on in the TUNE and ON positions. The control also switches the screen voltage to 360 volts in TUNE, 500 volts in ON, and breaks the screen voltage circuit in the STBY position.
 10. The RF LEVEL control (R51A) adjusts the amount of carrier insert on AM and CW operation. Insertion is increased with clockwise rotation.
 11. The ZERO LEVEL control (R51B) adjusts the amount of carrier insert for receiver zeroing. Insertion is increased with clockwise rotation.
 12. The METER control (SW5) switches the meter M1 to appropriate shunts and circuits to measure the power amplifier plate voltage, grid current, screen current and the exciter output.
 13. The OUTPUT control (R102) adjusts the exciter output meter sensitivity. After the exciter has been adjusted for maximum output, the control should be adjusted for an output meter reading of 100.
 14. The VFO knob controls the variable frequency oscillator tuning capacitor, C51. It also drives the pointer on the tuning dial.
 15. The EXCITER dial tunes the exciter 2nd mixer and driver tank circuits. The dial positions are designated by arcs covering the frequencies in each band.
 16. The AMPLIFIER dial adjusts the tank capacitor (C103) of the exciter amplifier.
 17. The POWER AMPLIFIER control provides single knob tuning of the plate circuit inductor (L206) and capacitor (C216). The dial positions are designated by arcs on the panel which cover the frequencies in each amateur band.
 18. The POWER AMP LOADING controls provide switching of the fixed loading capacitors by switch (SW203) and adjustment of the variable loading capacitor (C217) to obtain the desired plate current (loading). The fixed capacitor switch dial operates from positions 1 to 5 and the variable capacitor dial operates from position 0 to 6. Both dials increase the loading when turned in the clockwise direction.
 19. The EXT-INT AMPLIFIER switch (SW6) is located at the left side of the exciter chassis. The slide button must be in the INT position (nearest front of cabinet) when the Invader 2000 high power amplifier is used. If an external power amplifier (such as the Viking Thunderbolt or Kilowatt) is used, this switch, in the EXT position, provides SPDT relay contacts available at jack J2 for switching operating and blocking bias.
 20. FUSE (F1), located at the front of the exciter power supply chassis, protects the primaries of the exciter power supply transformers, the 866 filament transformer, the power amplifier screen supply transformer, the plate transformer contactor and the power amplifier tube filament transformer.
 21. FUSES (F301 and F302), located at the front of the power supply, are installed in both sides of the high voltage transformer primary for its protection.
 22. FUSE (F303) which is located at the front of the power supply is in the 500 volt screen voltage circuit. It is used to protect the PL175A screens from drawing excessive current in the event of a high voltage failure with the screen voltage on the tubes.
 23. The clear indicator (I), which is located directly above the multi-purpose meter, indicates when the power amplifier filaments are on.

- C. 24. The red indicator (I_2), which is the center indicator, indicates when the unit is in the transmitting condition.
25. The amber indicator (I_3), which is located directly above the plate current meter, indicates when the power amplifier plate voltage is on.

D. OPERATING PROCEDURES

1. CW Operation

The Invader 2000 utilizes mixer type keying as well as keying of the final amplifier stages so it is well suited for complete CW break-in operation if separate receiving and transmitting antennas are used or a TR switch such as the JOHNSON TR SWITCH (250-39) is used. For break-in operation, the OPERATE switch is left in the MAN position and the key need only be depressed to place the signal on the air.

For operation with an antenna relay and a single antenna for transmitting and receiving, the OPERATE switch should be in MAN for transmitting and STBY for receiving.

2. SSB and AM Operation

The procedure for operation SSB and AM would normally either include an antenna relay or a TR switch. The following three methods of operating are available:

- a. MAN. Manual operation energizes the transmitter by means of the OPERATE control on the front panel. The unit is in the receive position when the OPERATE switch is in STBY and in the transmit position when the OPERATE switch is in MAN.
- b. PTT. Push-to-talk operation is accomplished by rotating the OPERATE switch to VOX-PTT and turning the VOX GAIN and the ANTI-Trip Gain controls (located on the rear of the chassis, Figure D) to their most counter-clockwise position. A push-to-talk type microphone which will ground pin 2 of J6, when the PTT switch of the microphone is pushed, must be used. The transmitter is placed on the air by depressing the push-to-talk switch on the microphone and is placed in the receive condition when the switch is released.
- c. VOX. The Invader 2000 can be used as a voice operated unit in AM and SSB. The Voice Operate (VOX), Anti-trip (AT) and the Time Delay (TD) controls should be adjusted per the VOX and AT adjustments described in the ADJUSTMENT AND OPERATION section of this manual.

3. Zeroing

The ZERO position of the OPERATE control is used to provide means of "zero beating" the transmitter with the receiver so the transmitter is on the desired frequency. It can be used in all modes of operation and its level is independent of any of the other levels. The adjustment of the ZERO LEVEL is described in the ADJUSTMENT AND OPERATION section of this manual.

E. ADJUSTMENT AND OPERATION

Before voltage is applied to the Invader 2000, the PA PLATE switch must be in the STBY position. This will avoid applying high voltages to the 866A tubes while their filaments are starting to heat. New 866A tubes should be preheated for 30 minutes so all the mercury is vaporized before high voltage is applied. Subsequent operation will require only 15 to 30 seconds of preheating time before the high voltage is applied to the tubes.

E. 1. CW Operation

The Invader 2000 should be adjusted for CW operation using the following procedure.

- a. Before primary power is applied to the unit, turn the OPERATE switch to OFF, MODE switch to CW, PA FILAMENT switch to ON and the PA PLATE switch to STBY.
- b. Turn the VFO, EXCITER, BAND, AMPLIFIER, POWER AMPLIFIER, and PWR AMP LOADING dials to the desired band and frequency. Approximate dial positions for each band are shown in Figure B. Turn the LOADING switch to the AMP (clockwise) position as shown in the small panel opening. Turn the METER switch to OUTPUT and the RF LEVEL control fully clockwise.
- c. Turn the OPERATE switch to STBY and allow the 866A and other tube filaments to become fully heated (15 to 30 seconds time).
- d. Plug a key into the jack (J1) located at the rear of the exciter chassis. Keep the key contacts closed during adjustment of the transmitter. (NOTE: The key jack is a closed circuit type--removal of key closes circuit and is the same as key inserted and contacts closed).
- e. Turn the OPERATE switch to MAN, and adjust the AMPLIFIER dial for maximum output on the OUTPUT meter. Next adjust the EXCITER dial for maximum output on the OUTPUT meter. It may be necessary to adjust the OUTPUT control to keep the meter pointer on the scale.
- f. Turn the METER switch to GRID and adjust the RF LEVEL control for 10 ma of grid current.
- g. Turn the PA PLATE switch to ON and adjust the POWER AMPLIFIER dial for resonance (dip in plate current).
- h. Adjust the PWR AMP LOADING dials (load increases in the clockwise direction) until the necessary current is secured which will give one kilowatt input (plate voltage times plate current = 1000 watts). During the loading process, the grid current should be maintained at 10 ma (adjust RF LEVEL control) and the POWER AMPLIFIER tank dial adjusted for resonance.

Open the key contacts and the unit is ready for operation on CW.

2. Linear Operation Loading Current

The linearity of any linear amplifier depends largely upon the proper loading of the amplifier. The Invader 2000 utilizes the following procedure for determining the proper amount of loading of the amplifier. It also compensates for differences in vacuum tubes and permits optimum loading without the use of an oscilloscope.

- a. Before primary power is applied to the unit, turn the OPERATE switch to OFF, MODE switch to LSB or USB, AUDIO control to 0, PA FILAMENT switch to ON, PA PLATE switch to STBY and the RF LEVEL knob fully counter-clockwise.
- b. Turn the OPERATE switch to STBY for 15 to 30 seconds and then turn it to the MAN, position.
- c. Turn the PA PLATE switch to ON and read the static plate current on the meter M₂. Turn the PA PLATE switch to STBY, the OPERATE switch to OFF, and record the value of static plate current.

E. 2.

$$I_p \text{ (static)} = \underline{280}$$

- d. Refer this value of static plate current to the graph curve below and determine the proper plate current loading point for both SSB and AM linear operation on all bands. Record this value of loading current for future use as this will be the plate current to which the amplifier will be loaded when tuning up for SSB or AM operation.

For example, a static plate current of 280 ma calls for a loading current value of 320 ma.

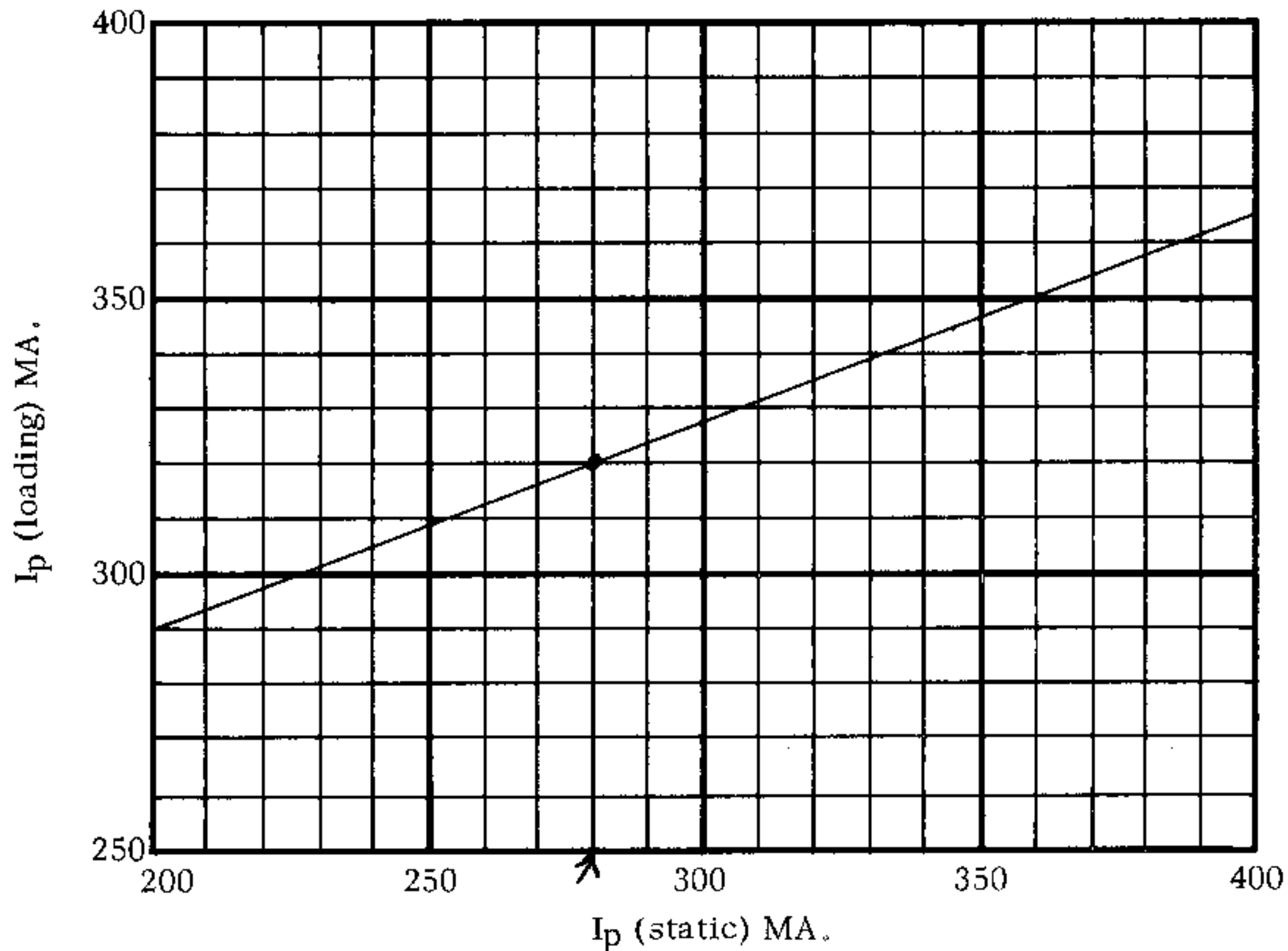

3. AM Linear Operation

Before the following adjustments for AM linear operation can be made, it is necessary to determine the value of the linear operation loading current as described in section 2.

- a. Prior to applying primary power to the unit, place the OPERATE switch at OFF, MODE switch at CW, PA FILAMENT switch at ON and the PA PLATE switch at STBY.
- b. Turn the VFO, EXCITER, BAND, AMPLIFIER, POWER AMPLIFIER, and PWR AMP LOADING dials to the desired band and frequency. Approximate dial positions for each band are shown in Figure B. Turn the LOADING switch clockwise to the AMP position as indicated in the small panel opening. Turn the METER switch to OUTPUT and the RF LEVEL control fully clockwise.
- c. Plug a microphone into the jack (J6) located at the rear of the exciter chassis and turn the AUDIO control to the counter-clockwise stop.
- d. Turn the OPERATE switch to STBY for 15 to 30 seconds to allow the 866 and other tube filaments to become fully heated.

- E. 3.
- e. Place the OPERATE switch at MAN and adjust the AMPLIFIER dial for maximum output on the OUTPUT meter. Next adjust the EXCITER dial for maximum output on the meter. It may be necessary to adjust the output control to keep the meter pointer on the scale.
 - f. Turn the METER switch to GRID and adjust the RF LEVEL control for 10 ma of grid current.
 - g. Turn the PA PLATE switch to TUNE and adjust the POWER AMPLIFIER dial for resonance (dip in plate current).
 - h. Adjust the PWR AMP LOADING dials (load increases in the clockwise direction) until the plate current is the same value as the linear operation loading current secured in section 2. During the loading process, the grid current should be maintained at 10 ma (adjust RF LEVEL control) and the POWER AMPLIFIER tank dial adjusted for resonance after each adjustment of the loading controls.

When the power amplifier is drawing the linear operation loading current, there should be a 15 to 20 ma dip in plate current as the POWER AMPLIFIER dial is adjusted through resonance. If this amount plate current dip is not secured, reduce the load slightly and retune the POWER AMPLIFIER dial for resonance.

- i. Turn the OPERATE switch to STBY, the MODE switch to AM, the PA PLATE switch to ON and the RF LEVEL dial to the counter-clockwise stop position.
- j. Turn the OPERATE switch to MAN and adjust the RF LEVEL dial clockwise until the plate current meter indicates the current necessary for 800 watts input (plate voltage times the plate current in amperes).
- k. While talking into the microphone in a normal voice, adjust the AUDIO control clockwise until the plate meter increases about 40 ma on voice peaks over the current secured in step j. above (the grid current will be about 2 to 5 ma on voice peaks).

4. SSB Linear Operation

Before the following adjustments for SSB operation can be made, it is necessary to determine the value of the linear operation loading current as described in section 2.

- a. Prior to applying primary power to the unit, place the OPERATE switch at OFF, MODE switch at CW, PA FILAMENT switch at ON and the PA PLATE switch at STBY.
- b. Turn the VFO, EXCITER, BAND, AMPLIFIER, POWER AMPLIFIER, and PWR AMP LOADING dials to the desired band and frequency. Approximate dial positions for each band are shown in Figure B. Turn the LOADING switch clockwise to the AMP position as indicated in the panel opening. Turn the METER switch to OUTPUT and the RF LEVEL control fully clockwise.
- c. Plug a microphone into the jack (J6) located at the rear of the exciter chassis and turn the AUDIO control fully counter-clockwise.
- d. Turn the OPERATE switch to STBY for 15 to 30 seconds to allow the 866 and other tube filaments time to become fully heated.

INVADER 2000 AM OPERATION

Some operators have a tendency to overdrive equipments by running the audio gain too high. This can cause overmodulation and distortion particularly in AM operation.

To reduce the possibility of overmodulation, the following procedure is recommended for AM operation:

Advance AUDIO gain control while speaking into the microphone until monitored signal begins to distort or roughen. Operate just below this point. The signal may be monitored on your receiver, an oscilloscope or by competent on-the-air reports.

Approximate plate meter peaks (not average) of 40 ma provide 100% modulation. However, this will vary widely with individual voice characteristics and satisfactory audio should govern rather than any specific meter reading. Operating as described, you can be assured of maximum power output regardless of the meter reading produced by the individual characteristics of your voice.

- E. 4.
- e. Place the OPERATE switch at MAN and adjust the AMPLIFIER dial for maximum output on the OUTPUT meter. Next adjust the EXCITER dial for maximum output on the meter. It may be necessary to adjust the OUTPUT control to keep the meter pointer on scale.
 - f. Turn the METER switch to GRID and adjust the RF LEVEL control for 10 ma of grid current.
 - g. Turn the PA PLATE switch to TUNE and adjust the POWER AMPLIFIER dial for resonance (dip in plate current).
 - h. Adjust the PWR AMP LOADING dials (load increases in the clockwise direction) until the plate current is the same value as the linear operation loading current secured in section 2. During the loading process, the grid current should be maintained at 10 ma (adjust RF LEVEL control) and the POWER AMPLIFIER tank dial adjusted for resonance after each adjustment of the loading controls.

When the power amplifier is drawing the linear operation loading current, there should be a 15 to 20 ma dip in plate current as the POWER AMPLIFIER dial is adjusted through resonance. If this amount of plate current dip is not secured, reduce the load slightly and retune the POWER AMPLIFIER dial for resonance.

- i. Turn the OPERATE switch to STBY, the MODE switch to either LSB or USB, and the PA PLATE switch to ON.
- j. Move the OPERATE switch to MAN and adjust the AUDIO control in a clockwise direction until the power amplifier plate current kicks upward approximately 175 to 200 ma above the idle plate current on voice peaks. The maximum legal power limit is reached when the average meter current reads approximately 475 ma (plate voltage times average plate current equal to 1000 watts).

Operation may now commence using MAN, VOX or PTT type operation.

5. VOX-PTT, AT, ZERO, and MAN Adjustments

a. VOX-PTT Operation

Voice operate or Push-to-talk operation of the transmitter is available in SSB and PTT operation in AM. Voice Operate is accomplished by placing the OPERATE switch in the VOX-PTT position. Grounding pin 2 of the microphone connector through the microphone operates the transmitter in Push-to-talk.

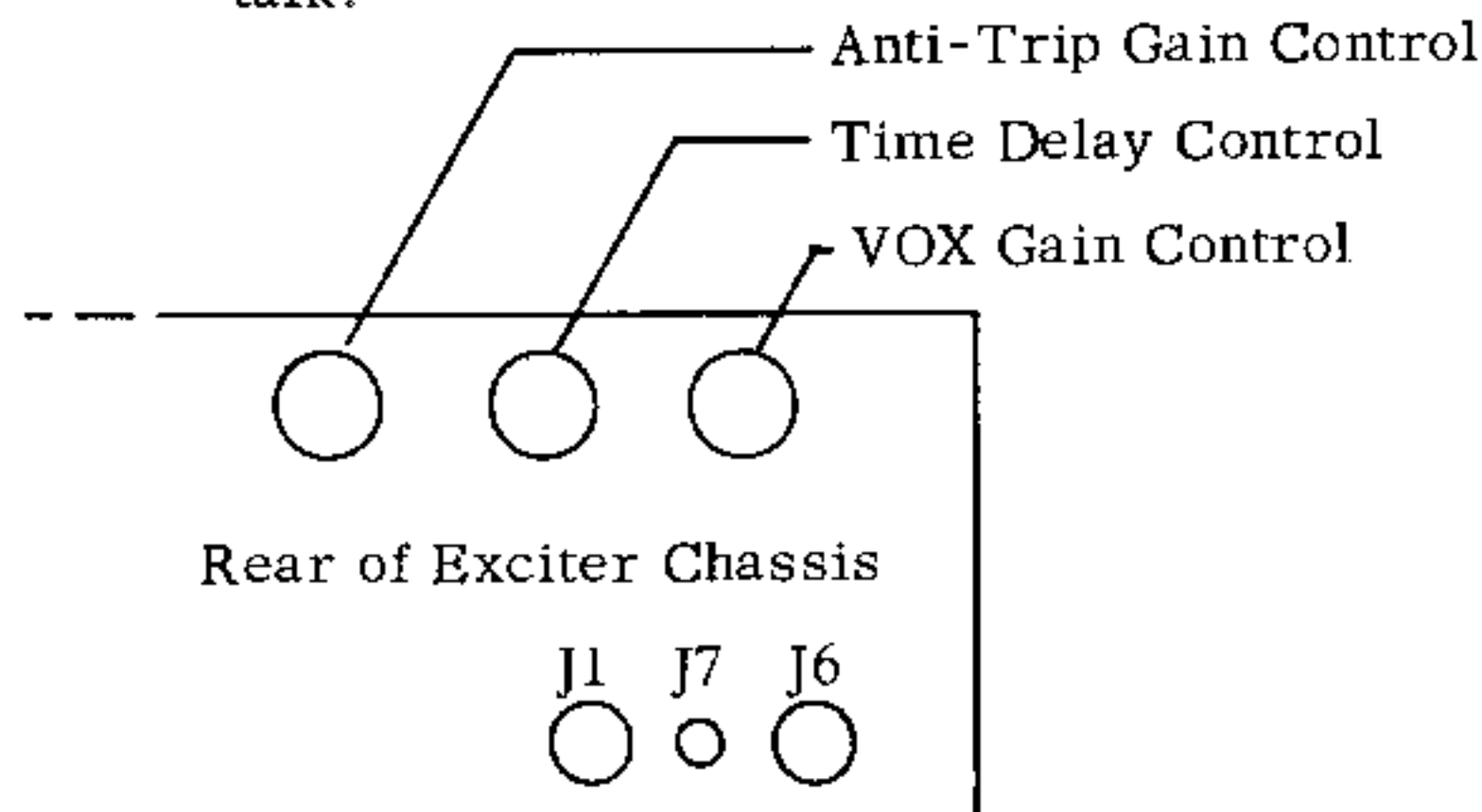

- E. 5. a. The VOX gain is adjusted by the potentiometer (R80) located at the rear of the chassis. The VOX gain should be adjusted with the VOX time delay control (R83, located at the rear of the chassis) and the Anti Trip control (R94) fully counter-clockwise. While speaking with normal voice volume, adjust the VOX gain slightly beyond the point where the relay operates. Now adjust the time delay control for the desired time for the relay to release after the end of a word or speech. The VOX may be disabled by rotating the VOX gain control (R80) fully counter-clockwise.

b. ANTI-TRIP Adjustments

Connect the receiver and speaker to jack (J2) as shown in the INSTALLATION section of this manual. The OPERATE switch should be in the VOX-PTT position and the VOX gain adjusted before the anti-trip can be adjusted.

Adjust the receiver volume to normal listening level. If the speaker audio activates the VOX relay, advance (clockwise) the anti-trip control until this condition is eliminated.

In many receivers, the STAND-BY or TRANSMIT functions merely removes the B+ from the receiver circuits. When the system is returned to the receive condition, a loud click is usually evident which will activate the voice operated VOX circuits thus shutting off the receiver. This will become a re-occurring process with the click noise activating the VOX circuit and the absence of noise activating the receiver. The circuits shown in the INSTALLATION section do not break the receiver B+ and do not have this trouble.

c. ZERO Adjustment

Zero-beating of a station is provided for when the OPERATE switch is in the ZERO position. This activates only the exciter less the exciter final which has a cut off bias applied to its grid. The ZERO LEVEL knob increases the strength of the zero-beat signal when it is turned clockwise.

6. Lower Power Operation

The exciter portion of the Invader 2000 may be operated as a lower power transmitter capable of power inputs of 200 watts PEP in SSB, 90 watts in AM, and 200 watts in CW. The high power amplifier is shut off by placing the PA PLATE switch at STBY and the PA FILAMENT switch may be, if desired, turned OFF. The antenna system coaxial line should be connected to the exciter RF output terminal (J8).

The exciter adjustment is the same for SSB, AM, and CW in that the exciter is adjusted for maximum output. The adjustment procedure is as follows:

- a. Before primary power is applied to the unit, turn the OPERATE switch to OFF, MODE switch to CW, PA FILAMENT to OFF (may be left on if rapid switching from low to high power is contemplated) and the PA PLATE switch to STBY.
- b. Turn the VFO, EXCITER, LOADING, BAND and AMPLIFIER dials to the desired band and frequency. Approximate dial positions for each band are shown in Figure B.
- c. Turn the METER switch to OUTPUT, the RF LEVEL control fully clockwise, and the AUDIO control to 0.
- d. Move the OPERATE switch to STBY for 15 to 30 seconds to allow the filaments to become fully heated.

VOX and Anti-Trip Operation

A basic understanding of voice actuated transmitter operation (VOX) and anti-trip control (AT) will help the operator to obtain satisfactory VOX and AT operation of the Invader equipments. The block diagram below shows the Invader VOX and AT system.

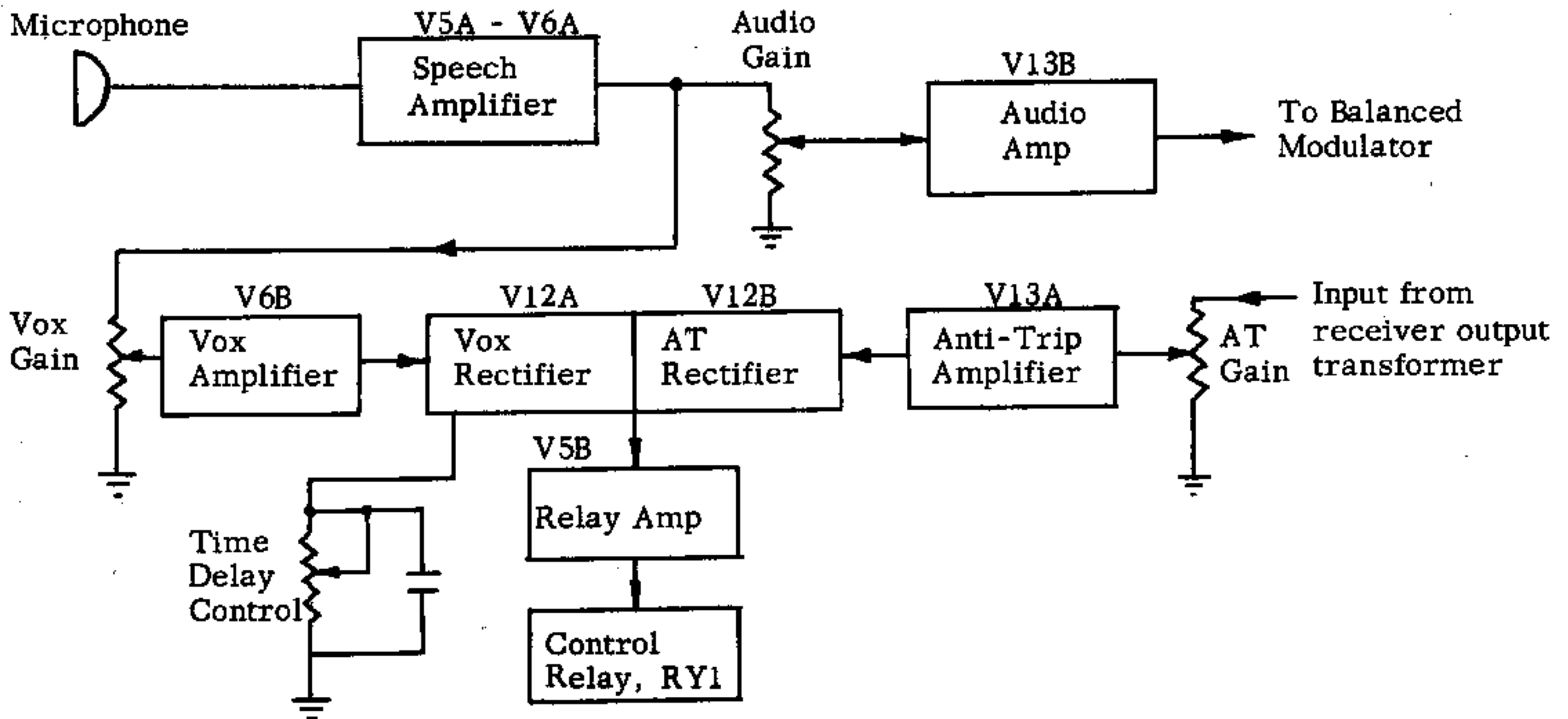

Speaking into the microphone is all that is necessary to place the transmitter on the air and mute the receiver when using VOX operation. The microphone output is amplified by the speech amplifier where the signal is split -- one path through the transmitter AUDIO gain control and audio amplifier to the balanced modulator and the other path through the VOX gain control and VOX amplifier. The audio output voltage of the VOX amplifier is rectified by the VOX rectifier and the rectified voltage is applied to the relay control tube which closes the control relay. The relay turns the transmitter on and mutes the receiver.

Anti-trip circuitry is necessary when a speaker is used for receiving and VOX operation is desired. The sound from the speaker will enter the microphone and actuate the VOX circuit unless AT is used to prevent such undesirable action. Audio voltage is fed from the receiver output transformer (which also feeds the speaker) through the AT gain control and AT amplifier to the AT rectifier, where the anti-trip audio voltage is rectified. The AT rectifier and VOX rectifier are connected to cancel, that is, equal signals through the two rectifiers produce zero output and the relay tube and relay are not actuated. Thus, the speaker sound fed through the microphone is cancelled by the anti-trip voltage and the transmitter is not placed on the air. The operator's voice level at the microphone must be higher than the speaker level if the VOX amplifier is to develop enough output to overcome the AT voltage and actuate the relay tube.

A time delay or holding circuit is provided by the adjustable time constant, R83, R85 and C119 (cathode of V12A). The time delay control, TD, can be adjusted to provide a delay from a fraction of a second to 2 seconds before the transmitter goes off after a word or group of words. This prevents dropout in the middle of a word or sentence. TD should be adjusted to suit the preference of the individual operator.

The most frequent cause of improper VOX-AT operation is improper speaker placement in respect to microphone. When the speaker is too close to the microphone, normal, comfortable speaker volume will produce such a high level at the microphone that the AT voltage necessary to

keep the unit off the air cannot be overcome by the operator's voice level. The speaker should be placed a few feet "behind" the microphone so any directional characteristic of the microphone will discriminate against the speaker sound. Close talking will help to provide a more favorable voice-to-speaker sound level.

Other difficulties and their causes are:

<u>Difficulty</u>	<u>Cause</u>
Vox inoperative, VOX gain on	VOX gain too low; AT gain too high; defective microphone or low output; speaking too far from microphone; improper microphone connection; defective tube; speaker level too high
AT inoperative	AT gain too low; improper connection to receiver; speaker too close to microphone; defective tube
Equipment chatters on and off or erratic operation	Improper settings on VOX and AT gain; receiver produces click or thump in speaker when turned on (must be muted differently); speaker too close to microphone to permit correct adjustment; noisy antenna relay (must be quieted); receiver volume too high; high acoustic background noise

Once the VOX-AT system is properly adjusted care should be exercised not to turn the receiver volume above the level used to obtain satisfactory operation. Otherwise, either the speaker level will trip the VOX or the AT level will prevent voice control of VOX. The greater the separation between microphone and speaker, the greater the volume level tolerance of the system.

INVADER AM OPERATION

Some operators have a tendency to overdrive equipments by running the audio gain too high. This can cause overmodulation and distortion particularly in AM operation.

To reduce the possibility of overmodulation, the following procedure is recommended for AM operation:

Advance AUDIO gain control while speaking into the microphone until monitored signal begins to distort or roughen. Operate just below this point. The signal may be monitored on your receiver, an oscilloscope or by competent on-the-air reports.

Approximate meter peaks (not average) of 55 provide 100% modulation. However, this will vary widely with individual voice characteristics and satisfactory audio should govern rather than any specific meter reading. Operating as described, you can be assured of maximum power output regardless of the meter reading produced by the individual characteristics of your voice.

- E. 6.
- e. Turn the OPERATE switch to MAN. and adjust the AMPLIFIER dial for maximum output on the OUTPUT meter. Next adjust the EXCITER dial for maximum output on the OUTPUT meter. It may be necessary to adjust the OUTPUT control to keep the meter pointer on the scale.
 - f. Simultaneously adjust the LOADING and AMPLIFIER controls until further increasing or decreasing the loading will not increase the output any further. The LOADING control increases the loading when rotated clockwise and decreases the loading by counter-clockwise rotation.

The loading dial is rotated more than 180° to switch the fixed loading capacitors. A slight resistance to rotation will be felt as the dial turns the fixed capacitor switch and then the dial will be free for another 180° rotation of the loading variable capacitor.

The fixed capacitor switch positions are shown in the panel opening and number from 1 through 9. The loading increases as the numbers increase.

- g. Adjust the OUTPUT control until the OUTPUT meter reads 100. The exciter unit is now ready for operation in SSB and CW depending upon the position of the MODE switch. The OUTPUT meter will read 100 in CW and will talk up to 35 on voice peaks in SSB (switch MODE to LSB or USB) when the AUDIO control is adjusted.
- h. AM operation requires an additional adjustment to those in step "g" above. With the MODE switch in CW, adjust the RF LEVEL control until the OUTPUT meter just starts to drop below 100. When the MODE switch is turned to AM, the RF LEVEL should be adjusted for meter reading of 50 and the AUDIO control advanced to produce a meter reading of approximately 55 on modulation peaks.

F. ALIGNMENT AND MAINTENANCE

1. EXCITER ALIGNMENT

A. EQUIPMENT REQUIRED

1. Communications Receiver, with BFO, capable of detecting frequencies (in MC) of

3.550	8.9985	21.2	25.6
3.800	9.0015	21.5	28.3
4.050	14.2	24.5	28.8
4.9 to 5.5	21.1	25.0	29.4
7.3			

WARNING: Alignment should be made only by a well qualified technician using good test equipment. Tampering should be avoided! Align only when absolutely necessary and then only when area of difficulty has been determined.

The receiver is used as a detector and will be termed either receiver or detector in the instructions.

2. Vacuum tube voltmeter (RF).
3. Oscilloscope.
4. Audio oscillator capable of 0 to 5 MV output from 200 to 3000 cycles per second.
5. Assorted alignment tools and test leads
6. Microphone with push-to-talk bar.
7. 50 ohm dummy load capable of dissipating 150 watts.

B. PRELIMINARY

1. Make connections as follows:

- F. 1. B. 1. a. Connect ground lead to stud on rear apron of chassis.
- b. Connect dummy load to output jack J8. Plug cable into power supply and RF unit.
- c. Connect audio oscillator to microphone input J6.
- d. Plug line cord into 115 VAC line.
2. Turn OPERATE switch to STBY.
 - a. Check to see that all tubes and pilot lamps are lighted and of proper brilliance.
 - b. Check to see that VR tube V7 on the RF chassis and V104 on the power supply chassis are lighted.

C. CARRIER CRYSTAL AND 9 MC AMPLIFIER ADJUSTMENT

1. Equipment set-up.
 - a. BAND switch to 80, OPERATE switch to STBY.
 - b. Couple the detector (receiver) to the 9 mc oscillator area.
2. 9001.5 KC Crystal Adjustment
 - a. MODE switch to LSB
 - b. Adjust C1 to obtain 9001.5 KC frequency. (See K2b for final adj.).
3. 8998.5 KC Crystal Adjustment
 - a. MODE switch to USB.
 - b. Adjust C10 to obtain 8998.5 KC frequency (See K2b for final adj.).
 - c. Adjust R5 for equal output from both crystals, RF voltmeter probe on balanced modulator input (See Figure 6).
4. T2 Adjustment
 - a. MODE switch to CW.
 - b. RF LEVEL to maximum clockwise.
 - c. Connect vacuum tube voltmeter RF probe to pin 7 of V3.
 - d. Bottom core of T2 should be at bottom limit of its travel and top core should be at top limit of its travel.
 - e. Run top core of T2 through the first peak as evidenced on the voltmeter and adjust for peak reading at second peak reached.
 - f. Adjust bottom core to second peak reached.
 - g. Readjust top and bottom cores if necessary to obtain the maximum reading.
 - h. A minimum of 1 volt should be obtained at pin 7 of V3 with full RF LEVEL control. (If BAL. MOD. had been balanced previously, it will have to be unbalanced by rotating R8 and C13).
 - i. Move RF voltmeter to input of balanced mod. (Figure 6) MODE to LSB. Note voltmeter reading, MODE to USB, adjust R5 to obtain equal voltages on USB and LSB.
 - j. Rebalance balanced modulator per section K2a.

D. VFO SHIFT ADJUSTMENT

1. Equipment Set-Up.
 - a. Couple the receiver antenna to 2nd mixer plate circuit. Tune to about 3.8 mc, with BFO on.
 - b. Rotate R8 to extreme of travel to be sure balanced mod. is unbalanced.
 - c. MODE switch to LSB.

- F. 1. D. 1. d. BAND switch to 80.
- e. OPERATE to ZERO.
- f. ZERO LEVEL to maximum clockwise position.
- g. VFO to about 3.8 mc. until signal is heard in receiver. Peak EXCITER tuning on 80 if necessary to obtain stronger signal.
- 2. Shift Adjustment
 - a. Adjust receiver for exact zero beat with transmitter signal.
 - b. MODE to USB.
 - c. Adjust R31 to again obtain exact zero beat. R31 on left side of chassis (Figure 8) may be reached through hole in side of chassis.
 - d. MODE to LSB.
 - e. Readjust receiver for exact zero beat again.
 - f. Repeat steps b. through e. until no adjustment is needed in the receiver in step e. That is, until a zero beat is obtained in both LSB and USB at the same frequency.
 - g. Readjust R8 to rebalance balanced modulator per Section K2a.

E. VFO CALIBRATION

1. Equipment Set-Up

- a. Couple detector capable of covering 3550 KC and 4050 KC to pin 1 of V8.
- b. BAND switch to 80.
- c. MODE switch to LSB. OPERATE at ZERO.

2. Calibration

- a. Tune receiver and VFO dial to 4050 KC.
- b. Adjust slug in L8 to zero beat.
- c. Tune receiver to 3550 KC.
- d. Tune VFO toward 3550 KC until zero beat with receiver is secured. If the VFO dial is at a higher frequency than 3550 KC, increase the capacity of C52. If the VFO dial is at a lower frequency than 3550 KC, decrease the capacity of C52.
- e. Tune the receiver and VFO dial to 4050 KC and zero beat the VFO with the slug in L8.
- f. Repeat steps "c", "d"; and "e" until the VFO dial is exactly at 3550 KC and 4050 KC when it is zero beat with the receiver tuned to these frequencies.
- g. The frequency error should not be over 100 c.p.s. at these points.

NOTE: The VFO calibration can be no better than the accuracy of calibration of the receiver or frequency standard used for calibration.

F. VFO FILTER ALIGNMENT (T-3)

1. Equipment Set-Up

- a. Place RF probe at pin 1 of V8.
- b. BAND switch to 80.
- c. MODE switch to LSB, OPERATE switch in STBY.
- d. Set C61 to maximum capacity (notch in ceramic rotor toward mounting rivets). Figure 2.
- e. Set cores of T3 to full out, or withdrawn position.

2. Alignment Procedure

- a. Set VFO dial to 4 mc.

- F. 1. F. 2. b. Adjust top core of T3 to obtain maximum voltmeter reading.
- c. Set VFO dial to 3.6 mc.
- d. Adjust bottom core of T3 to obtain maximum voltmeter reading.
- e. Check the voltage output as the VFO is tuned from 3.5 to 4.0 mc. It should vary approximately + .2 volts with a dip in the middle of the band and peaks at 3.6 and 4.0 mc. The average voltage output should be about .6 volts.
- f. Adjust C61 to obtain .45 volts at 3.8 mc.
- g. Remove voltmeter.

G. HETERODYNE OSCILLATOR ALIGNMENT

1. Equipment Set-Up

- a. BAND switch to 10 HI.
- b. Couple receiver into heterodyne oscillator compartment.
- c. Pre-set C27 to nearly minimum capacity, L21 to maximum inductance, and C28 and C29 to where end of screw is flush with end of capacitor.

2. Alignment Procedure.

- a. L21 adjustment
 - (1) Tune receiver to 25.6 mc.
 - (2) Adjust L21 until crystal begins to oscillate as evidenced by signal in receiver.
- b. 40 Meter Adjustment
 - (1) BAND switch to 40.
 - (2) Receiver to 21.5 mc.
 - (3) Check to see that crystal is oscillating at 21.5 mc. If it is not, continue to adjust L21 until it does. Usually there will be no adjustment required at this point.
- c. 10 MED Adjustment
 - (1) BAND switch to 10 MED.
 - (2) Receiver to 25.0 mc.
 - (3) Adjust C29 from maximum capacity toward minimum until the crystal just begins to oscillate reliably.
- d. 10 LO Adjustment
 - (1) BAND switch to 10 LO.
 - (2) Receiver to 24.5 mc.
 - (3) Adjust C28 from maximum capacity toward minimum until the crystal just begins to oscillate reliably.

NOTE: The adjustments in steps a. through d. must result in the crystals exhibiting a reliable starting characteristic.

H. 1ST MIXER ALIGNMENT (PRELIMINARY)

1. Equipment Set-Up

- a. Couple antenna of receiver into 6146 grid compartment.
- b. ZERO LEVEL control to maximum clockwise position.
- c. OPERATE switch to ZERO.
- d. Set neutralizing capacitors C82 (Figure 7) and C88 (Figure 2) to mid-capacity. MODE switch in LSB.

2. Alignment Procedure.

- a. 10 Meter Trap Adjustment
 - (1) BAND switch to 10 LO.
 - (2) EXCITER tuning to about "10".

- F. 1. H. 2. a. (3) VFO to 28.3 mc.
- (4) Tune receiver for max. signal at 24.5 mc.
- (5) Adjust 10 meter trap L22 (Figure 7) for minimum output as evidenced on the receiver. The proper point of adjustment is a null which will exhibit a sharp upswing when the controls are turned one way or the other.
- b. 40 Meter Alignment
 - (1) BAND switch to 40.
 - (2) EXCITER tuning to 40.
 - (3) Tune receiver to about 7.3 mc. until output signal is heard.
 - (4) Adjust 1st mixer plate coil L6 (40) for maximum receiver indication.

I. EXCITER AND 1ST MIXER FINAL ALIGNMENT

1. Equipment Set-Up

- a. Couple antenna of receiver into 6146 grid compartment.
- b. Connect dc probe of voltmeter to test point TP1 (Figure 2).

2. Alignment Procedure

- a. Bias Adjustment
 - (1) OPERATE switch to MAN.
 - (2) BAND switch to 80.
 - (3) EXCITER tuning to 10.
 - (4) Adjust R71 to obtain 60 to 62 volts on voltmeter.
- b. 10 MED Alignment.
 - (1) BANDSWITCH to 10 MED.
 - (2) EXCITER tuning to center of 10 mark.
 - (3) MODE to CW.
 - (4) OPERATE to MAN.
 - (5) VFO to 28.8.
 - (6) RF LEVEL to maximum clockwise position.
 - (7) Tune receiver to 28.8 mc.
 - (8) Adjust C41 (10), C73 (10), and C87 (10) for maximum indication on the receiver. Voltmeter will kick up above -60 to -62v when grid current is secured.

NOTE: Once grid current begins to flow, an indication will be seen on the VTVM and it may then be used for peaking of the circuits.

- c. Turn BANDSWITCH to 80 meters and tune EXCITER on 80 to see if drive is obtained. If not, adjust exciter tuning slugs to get drive--then go back and repeat 10 MED alignment (step 2b above).
- d. 10 HI Alignment
 - (1) BANDSWITCH to 10 HI
 - (2) MODE, OPERATE and RF LEVEL as in step b. above. VFO at 29.4 mc.
 - (3) Tune receiver until signal is heard near 29.4 mc.
 - (4) Rotate EXCITER tuning dial for maximum output.
 - (5) Adjust C40 (10) for maximum output as indicated on voltmeter.
- e. 10 LO Alignment
 - (1) BANDSWITCH to 10 LO.
 - (2) MODE, OPERATE, and RF LEVEL as in step b. above. VFO at 28.3 mc.
 - (3) Tune receiver until signal is heard near 28.3 mc.
 - (4) Rotate exciter tuning for maximum output.
 - (5) Adjust C42 (10) for maximum output.
- f. 15 Meter Alignment
 - (1) BANDSWITCH to 15.
 - (2) MODE, OPERATE, and RF LEVEL as in step b. above. VFO at 21.2 mc.
 - (3) EXCITER to center of "15".
 - (4) Tune receiver until signal is heard at 21.2 mc.

- F. 1. I. 2. f. (5) Adjust C43 (15), C76 (15), and C89 (15) for maximum output.
- g. 20 Meter Alignment.
 - (1) BANDSWITCH to 20.
 - (2) MODE, OPERATE, and RF LEVEL same as in step b. above. VFO at 14.2 mc.
 - (3) Exciter to center "20".
 - (4) Tune receiver until signal is heard at 14.2 mc.
 - (5) Adjust C77 and C91 for max. output.
- h. 40 Meter Alignment.
 - (1) BANDSWITCH to 40.
 - (2) MODE, OPERATE, and RF LEVEL same as in step b. above. VFO at 7.15 mc.
 - (3) EXCITER to center of "40".
 - (4) Tune receiver until signal is heard at 7.15 mc.
 - (5) Adjust C92 and C79 for max. output.

J. AUDIO DRIVE ADJUSTMENT

1. Equipment Set-Up.

- a. Connect audio oscillator to microphone input jack, J6.
- b. Set audio oscillator for 1300 cycle tone and 5 mv. output.
- c. Short out ALC buss by connecting a jumper from SW3C rear, terminal 5, to ground. (Purple wire to ground).
- d. AUDIO GAIN maximum clockwise position.
- e. BANDSWITCH to 10 MED position.
- f. Connect VTVM dc probe to TP1.
- g. MODE to CW.
- h. OPERATE to MAN.
- i. RF LEVEL to maximum clockwise.

2. Adjustment Procedure.

- a. Tune EXCITER tuning for maximum output as indicated on the VTVM.
- b. MODE to LSB.
- c. Adjust 9 mc GAIN control, R50, to obtain about 8-10 volt increase over the static, no signal, grid bias voltage.
- d. This should result in about -5.8 volts at the junction of R11 and R12 (on TS near L3) in the LSB and USB positions. If too high, adjust 9 mc GAIN, R50, to obtain -5.8 volts.
- e. Remove short from ALC line.

K. FINAL EQUIPMENT OPERATING CHECK

1. Equipment Set-Up.

- a. Connect 50 ohm shielded dummy load to output of transmitter.
- b. Connect VTVM (RF probe) to dummy load.
- c. Connect audio generator to microphone input.

2. Procedure.

- a. Carrier Balance (Balanced Modulator Null Adjustment).
 - (1) Equipment Set-Up
 - (a) MODE switch to LSB.
 - (b) BANDSWITCH to 15.
 - (c) EXCITER tuning to "80".
 - (d) VFO to 21.1 mc.

- F. 1 K. 2. a. (1) (e) AUDIO control to 0.
 (f) Audio generator to 1300 c.p.s., 5 MV.
- (2) Adjustment Procedure.
 (a) OPERATE switch to MAN.
 (b) Plate current should indicate approximately 40 milliamps. If reading is much different than this, check the screen and bias voltages and adjust R71, PA bias, to obtain 45 ma.
 (c) Audio to "10".
 (d) Set EXCITER tuning to the 15 position and peak for maximum output on output meter.
 (e) Adjust the AMPLIFIER and LOADING controls for maximum output being sure that the AMPLIFIER control is the last control adjusted.
 (f) AUDIO control to "0".
 (g) Adjust carrier balance controls R8 and C13 alternately to achieve combination which provides the minimum reading on the voltmeter.
- b. Carrier Frequency Adjustment.
 (1) Equipment Set-Up.
 (a) Equipment tuned and loaded as in step 2g above (on LSB).
 (b) Audio generator to 1300 c.p.s. at 5 mv. output.
- (2) Adjustment Procedure.
 (a) Advance AUDIO gain control to obtain 50 volts across the 50 ohm load.
 (b) Audio generator to 250 c.p.s.
 (c) Adjust C10 to obtain 25 volts of output.
 (d) Audio generator to 1300 cycles.
 (e) Recheck and adjust AUDIO gain if necessary to obtain 50 volts of output.
 (f) If adjustment is required, repeat step b. through e.
 (g) MODE switch to USB.
 (h) Audio generator to 1300 c.p.s.
 (i) Adjust AUDIO control to obtain 50 volts across dummy load.
 (j) Audio generator to 250 c.p.s.
 (k) Adjust C1 to obtain 25 volts of output.
 (l) Audio generator to 1300 cycles/sec.
 (m) Recheck and adjust AUDIO gain if necessary to obtain 50 volts of output.
 (n) If adjustment is required, repeat steps k. thru m.
 (o) Audio to "0".
 (p) Check RF output voltage. It should be less than .20 volts on both USB and LSB. If not, adjust carrier balance controls R8 and C13 until it is.
- c. VFO shift adjustment.
 (1) Equipment Set-Up.
 (a) Couple receiver or detector to output of transmitter.
 (b) Tune receiver to 21.1 mc. with BFO on.
 (c) BAND switch to 15.
 (d) VFO to 21.1 mc.
- (2) Shift Adjustment.
 (a) Tune and load transmitter in normal manner.
 (b) MODE switch to USB. OPERATE on MAN.
 (c) Adjust receiver for exact zero beat with transmitter signal.
 (d) MODE switch to LSB.
 (e) Adjust R31 to again obtain zero beat. (R31 control hole located at left side of chassis.)
 (f) MODE switch to USB.
 (g) Re-adjust receiver for exact zero beat again.
 (h) Repeat steps d. through g. until no retuning of the receiver is necessary in step g. to obtain zero beat.

F. 1. L. ADJUSTMENT OF R109

This adjustment is made at the factory and does not need to be changed unless the 6AH6, second mixer tube, is changed. This potentiometer is located on the left side of the Invader chassis.

If the second mixer tube is changed, the following procedure for adjusting R109 should be used.

1. Tune the Invader only to 21.270KC for full output in the CW mode.
2. Tune a receiver for a signal in the vicinity of 21.463KC.
3. If no signal or a weak signal is heard on the receiver or observed on the S meter, the factory adjustment of R109 is correct for the new tube.
4. If a strong signal is heard on the receiver or observed on the S meter, carefully adjust the R109 until the signal disappears or is considerably reduced in strength. The output meter may indicate a slight drop in output when the adjustment of R109 is at minimum 21.463KC signal. This reduction in output is only on CW and does not affect the AM or SSB output.

M. 6146 NEUTRALIZATION.

The 6146 amplifier has been properly neutralized at the factory. If, for some reason the neutralization has been changed (normally, neutralizing capacitor is 1/3 to 1/2 meshed), the amplifier may be reneutralized using the following procedure.

CAUTION: Because of the high voltage present, each adjustment of the neutralizing capacitor, C88, should be made through the hole in the front of the amplifier shield with the Invader in the OFF position. An insulated screw driver or preferably a phenolic rod with a tapered end should be used to make the adjustments of C88.

1. Place the negative lead of a 100 volt D.C. voltmeter into TP1 located next to the 12BY7 tube on the top of the chassis. Connect the positive lead of the voltmeter to the chassis.
2. Adjust the Invader to full output at 21.2 mcs. in the CW mode. Be sure the amplifier dial is adjusted to maximum output or resonance.
3. If the voltage rise is not greater than 2 to 4 volts as the amplifier dial is tuned each side of resonance, the amplifier stage is properly neutralized.
4. If the voltage drops when the amplifier dial is tuned on the high frequency side of resonance, the neutralizing capacitor C88 (located between the two 6146 tubes) should be adjusted for less capacity. This adjustment should be repeated until the voltmeter rises no more than 2 to 4 volts on either side of resonance.

F. 2. MAINTENANCE

A. ROUTINE

Periodic inspection of both mechanical and electrical parts is one of the best assurances of continued trouble-free operation. Excessive humidity, dirt and corrosion are the causes of many electronic equipment failures in a properly

operating unit. A soft brush, a dry air jet, or a small nozzle vacuum cleaner may be used to remove dust or other foreign material.

B. RELAYS AND SWITCHES

Relay contacts should be given a periodic inspection which should include cleaning with a burnishing tool (do not use sandpaper, emery cloth or a file). Switches should have any dust wiped off the sliding contact using a clean cloth. Check the moving parts of the relays and switches to see that they are not being hampered by accumulated dirt.

C. VENTILATION FANS

The fan motors should be given a sparse oiling about every six months using a good grade of SAE 20 or 30 oil. Do not use excessive oil which will only accumulate dust after running out of the motor. The fan blades should be cleaned and adjusted if accidentally bent so all blades are in line.

Both the intake and exhaust fan screens should be cleaned frequently with a clean cloth or a small nozzle vacuum cleaner.

D. GEAR DRIVE

The bearings of gears driving the power amplifier capacitor and inductor have been lubricated at the factory and no lubrication should be required for a number of years.

E. HIGH AMBIENT OR CONFINED SPACE INSTALLATION

Whenever the Invader 2000 power supply is installed in a confined space or operated in a high ambient temperature location, an exhaust fan should be installed on the outside of the perforated cover side next to the bleeder resistors. The fan is also recommended for installations when the equipment is used for prolonged periods of operation.

The fan assembly is the same as that used as an exhaust fan on the RF unit and is listed in the parts list. The extra fan assembly, which includes the shield, may be purchased separately if required.

G. CONVERSION FROM 230 VAC TO 115 VAC

The Invader 2000 power supply can be converted from 230 VAC to (3 wire primary) power to 115 VAC (2 wire primary) by making the following changes:

WARNING

Be sure the power cable is completely disconnected from the power source and the power supply.

1. Remove the jumper between terminals 2 and 3 of TS301.
2. Disconnect the black-green wire from terminal 1 of TS301 and connect it to terminal 3.
3. Disconnect the white wire from terminal 2 of TS301 and connect it to terminal 4.
4. Connect a jumper between terminal 1 and 4 of TS301.
5. Connect a wire from terminal 3 of TS301 to ground.
6. Connect the two narrow contacts of the power plug together with a short length of no. 16 wire.

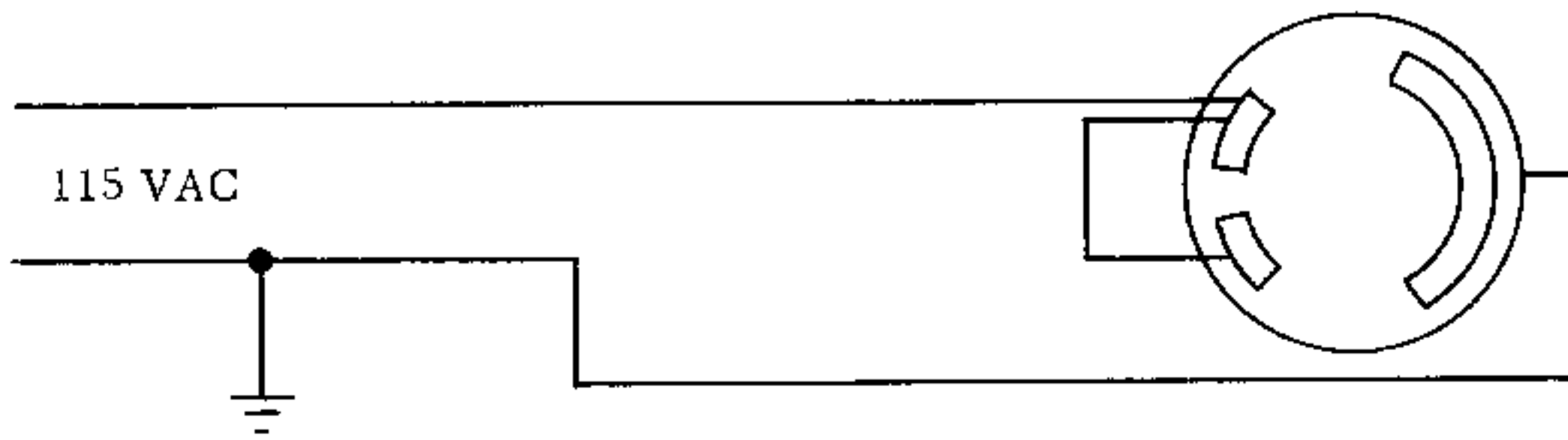

- G.
7. The 115 volt power source has one wire at ground potential and the other wire 115 volts above ground. This polarity must be observed when connecting the power cord to plug P301.
 8. Connect the 115 volt power lead which is above ground to the two narrow contacts on plug P301.
 9. Connect the 115 volt power lead which is at ground to the wide contact on plug P301.

10. **CAUTION.** Use a voltmeter to check steps 8, 9, and 10 to verify that the grounded 115 volt lead is connected to the wide contact of plug P301 and there is no voltage difference between this lead and ground. **BOTH POWER SUPPLY AND RF CHASSIS MUST BE GROUNDED.**

11. The power transformer and power input circuit will now be as shown below:

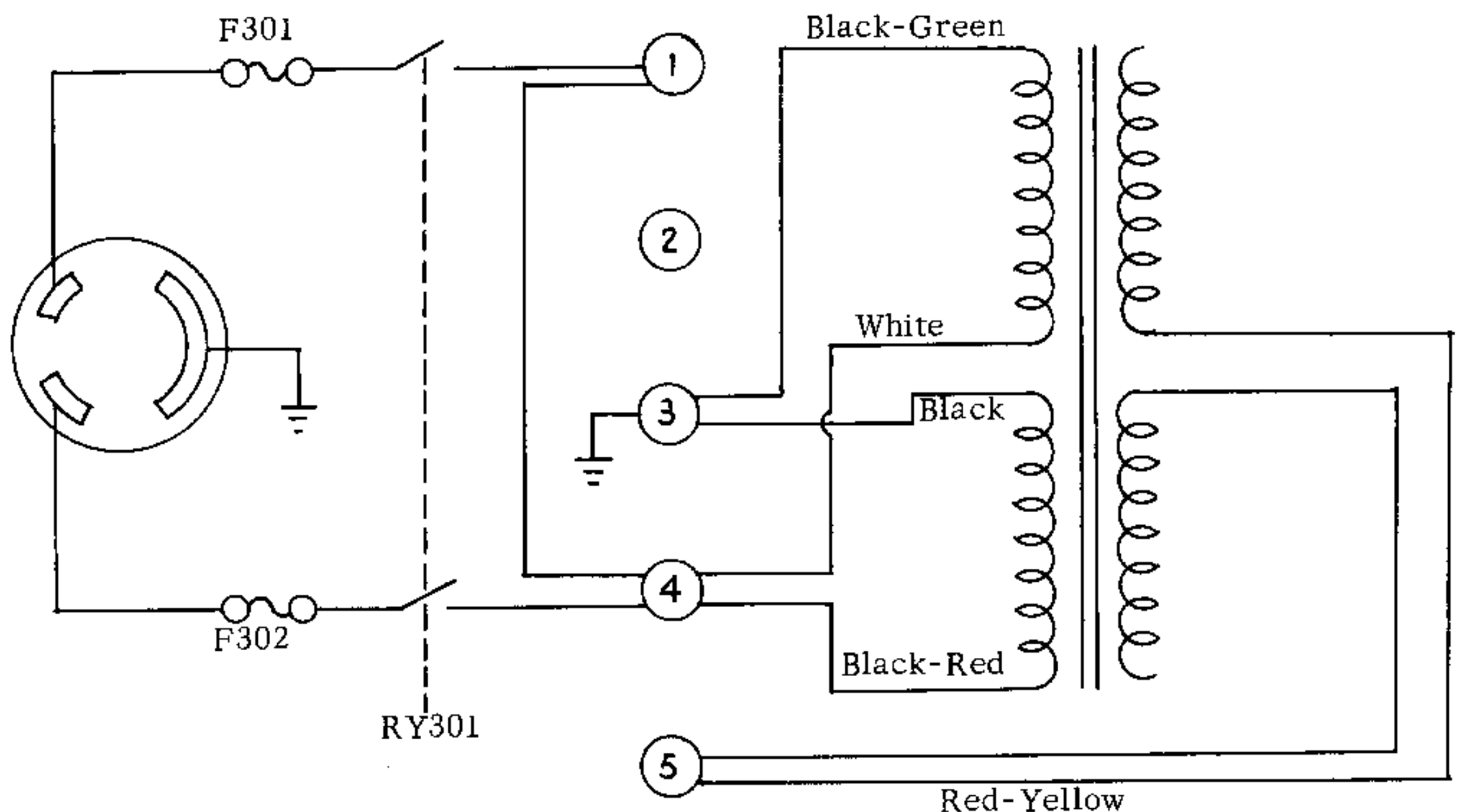

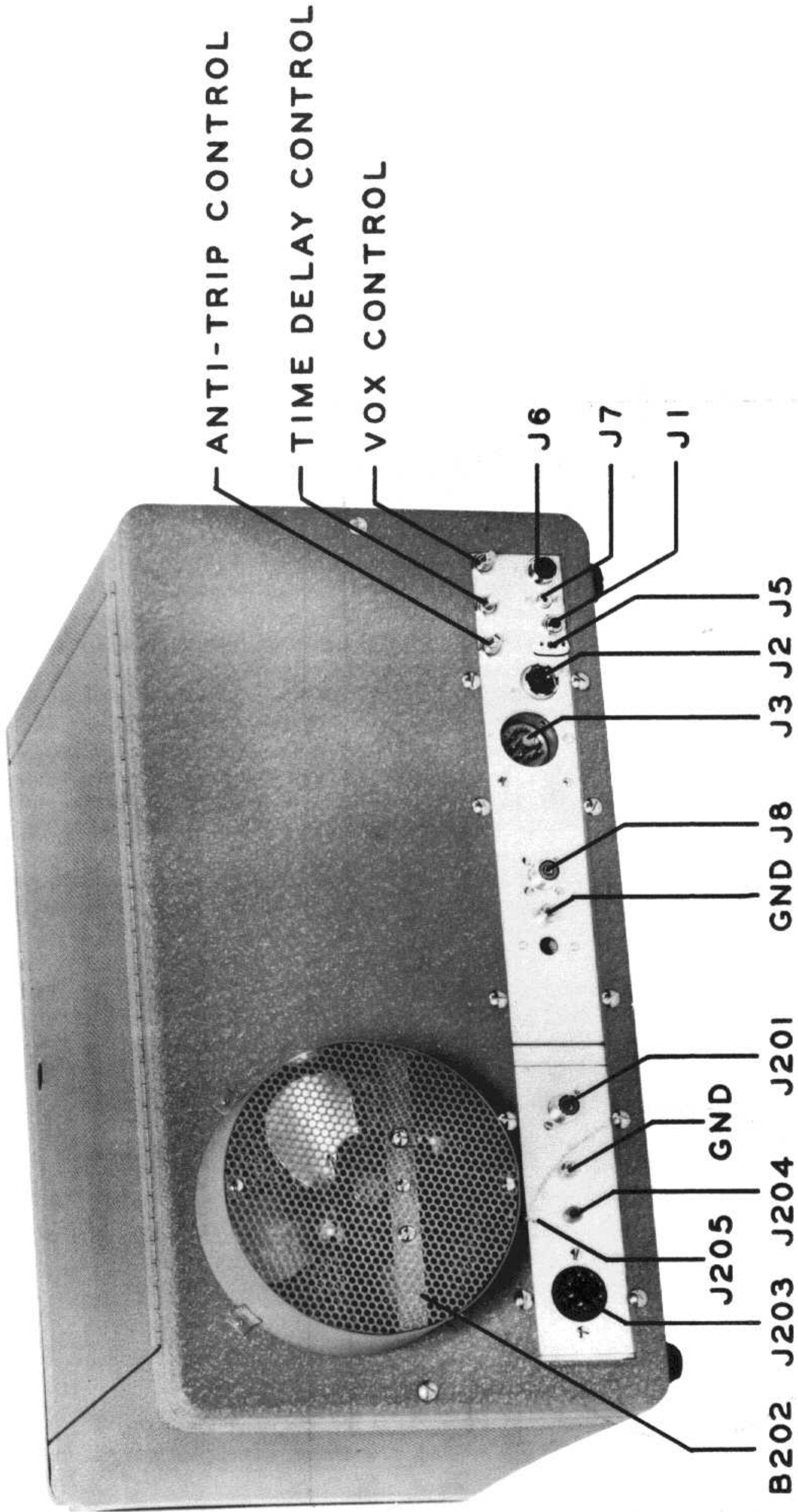

FIGURE 1. - CABINET - REAR VIEW

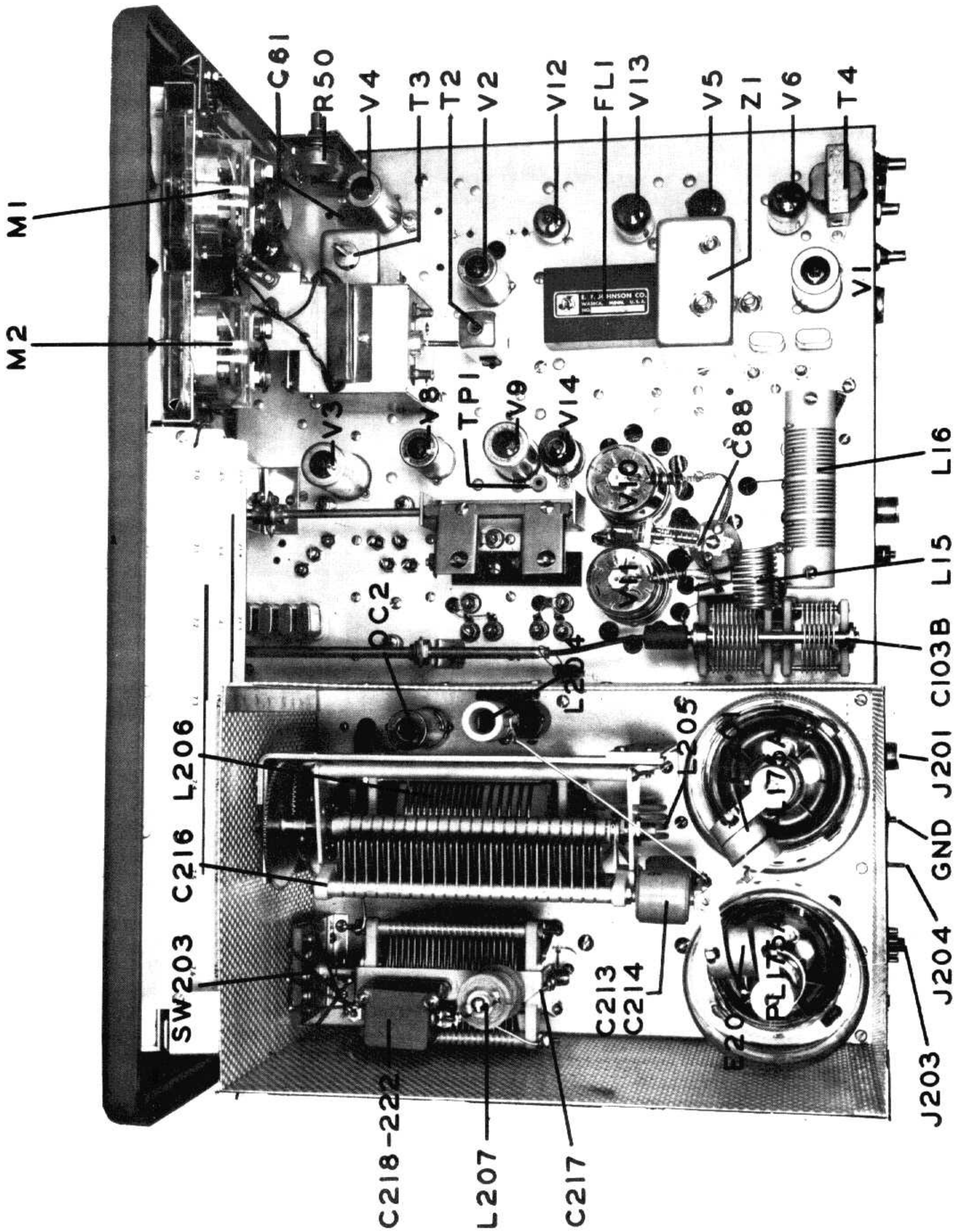

FIGURE 2. R.F. UNIT-TOP VIEW

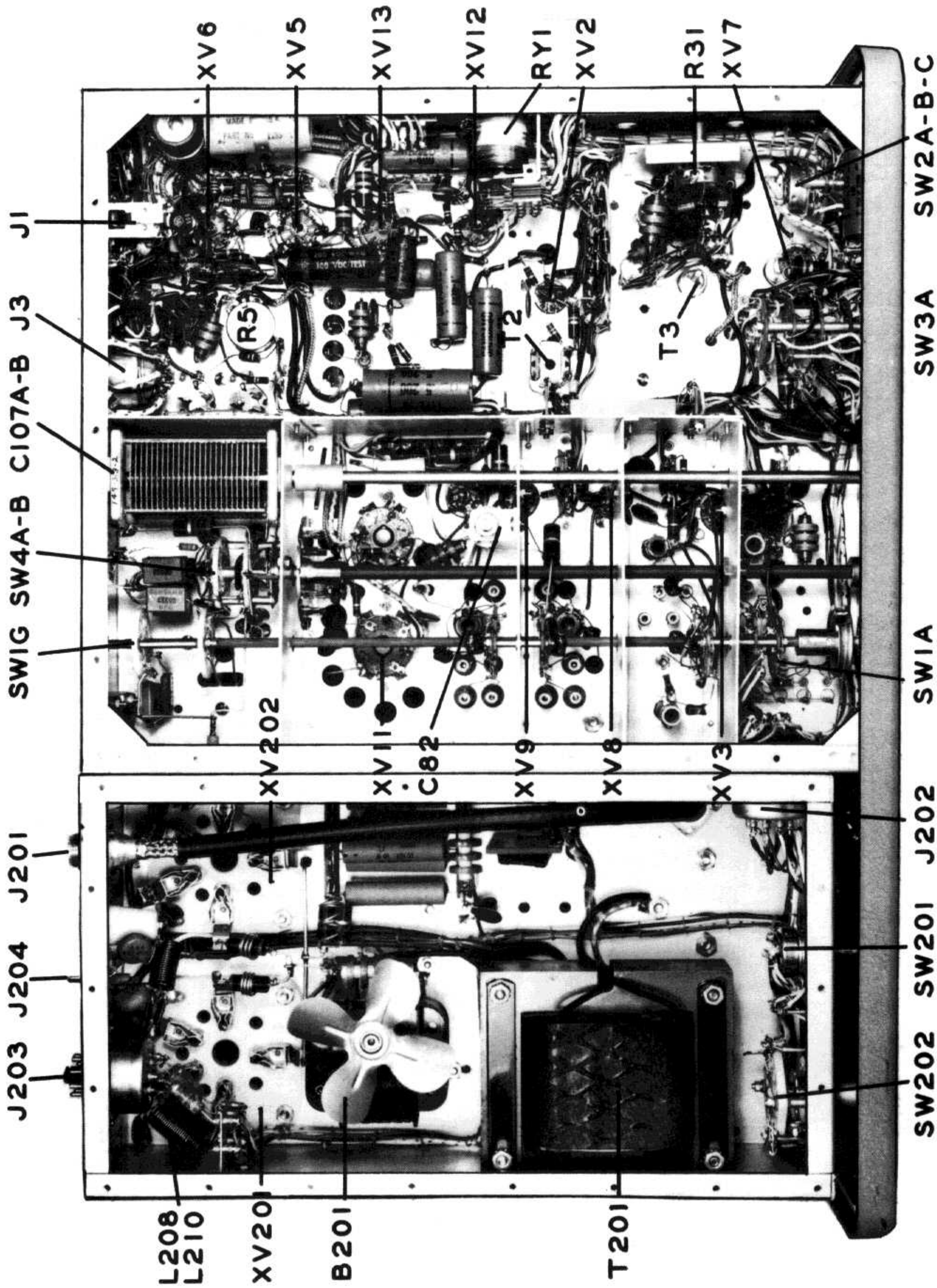

FIGURE 3.
CHASSIS - BOTTOM VIEW

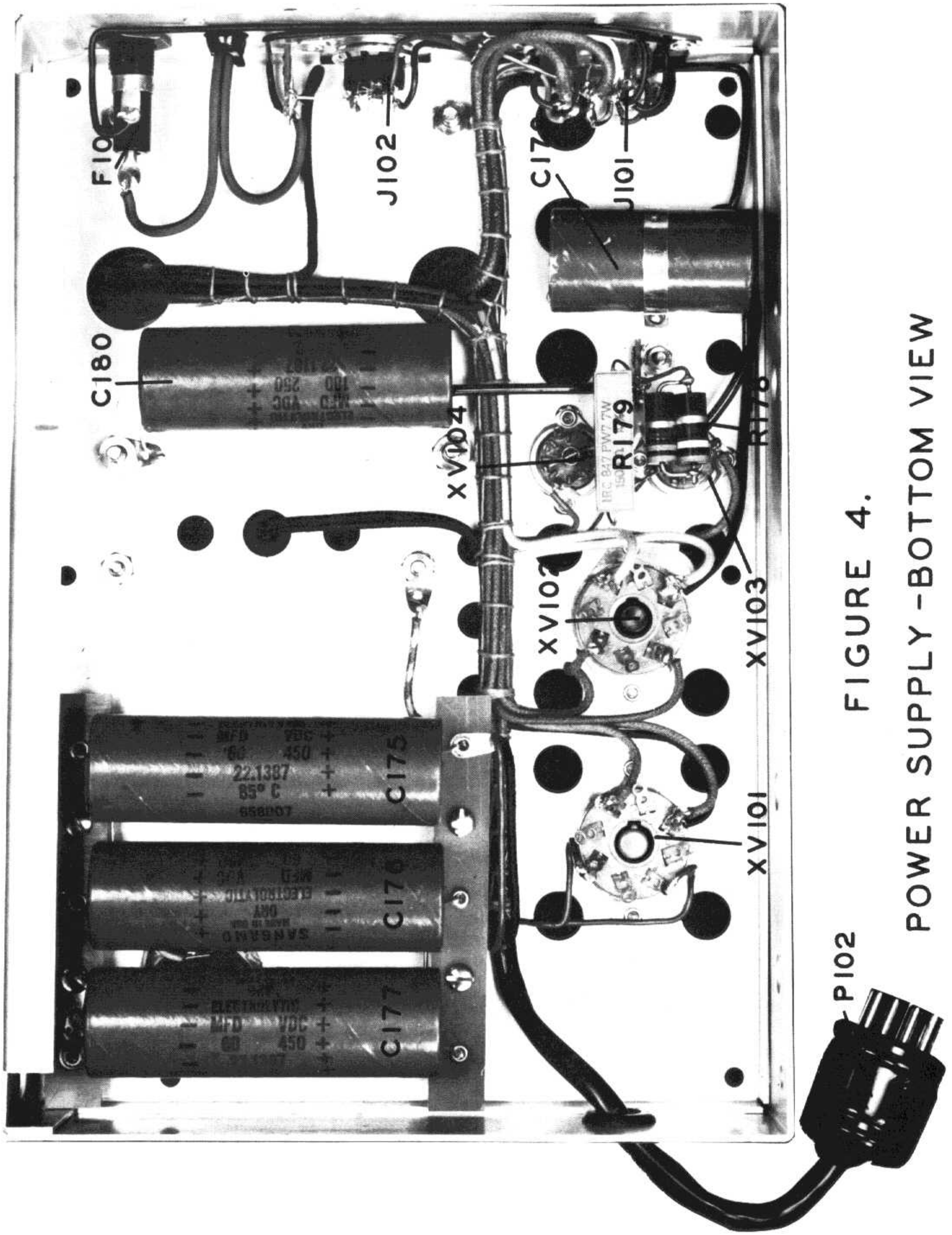

FIGURE 4.

POWER SUPPLY - BOTTOM VIEW

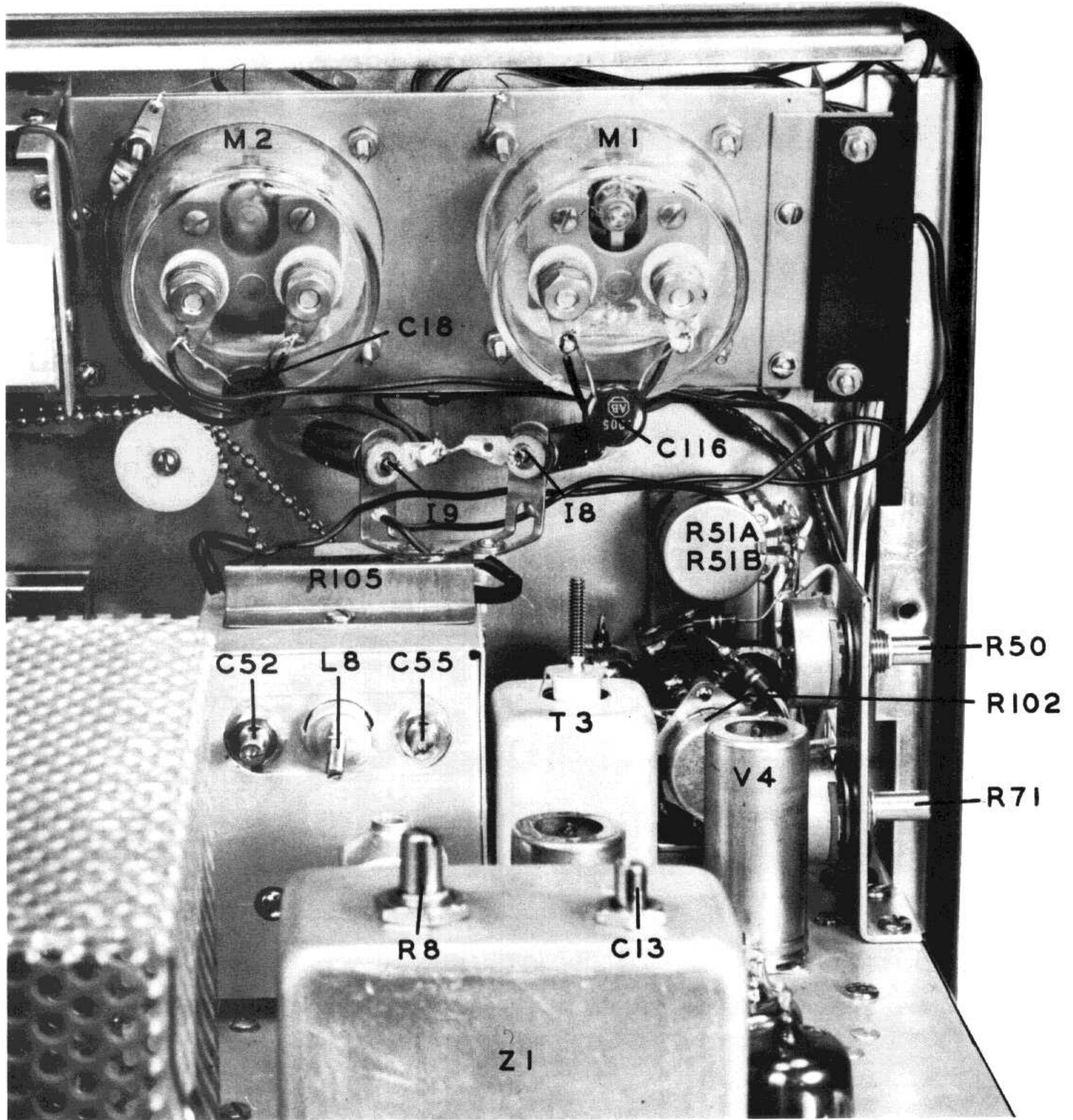

FIGURE 5
VFO, BALANCED MODULATOR
AND METER-REAR VIEW.

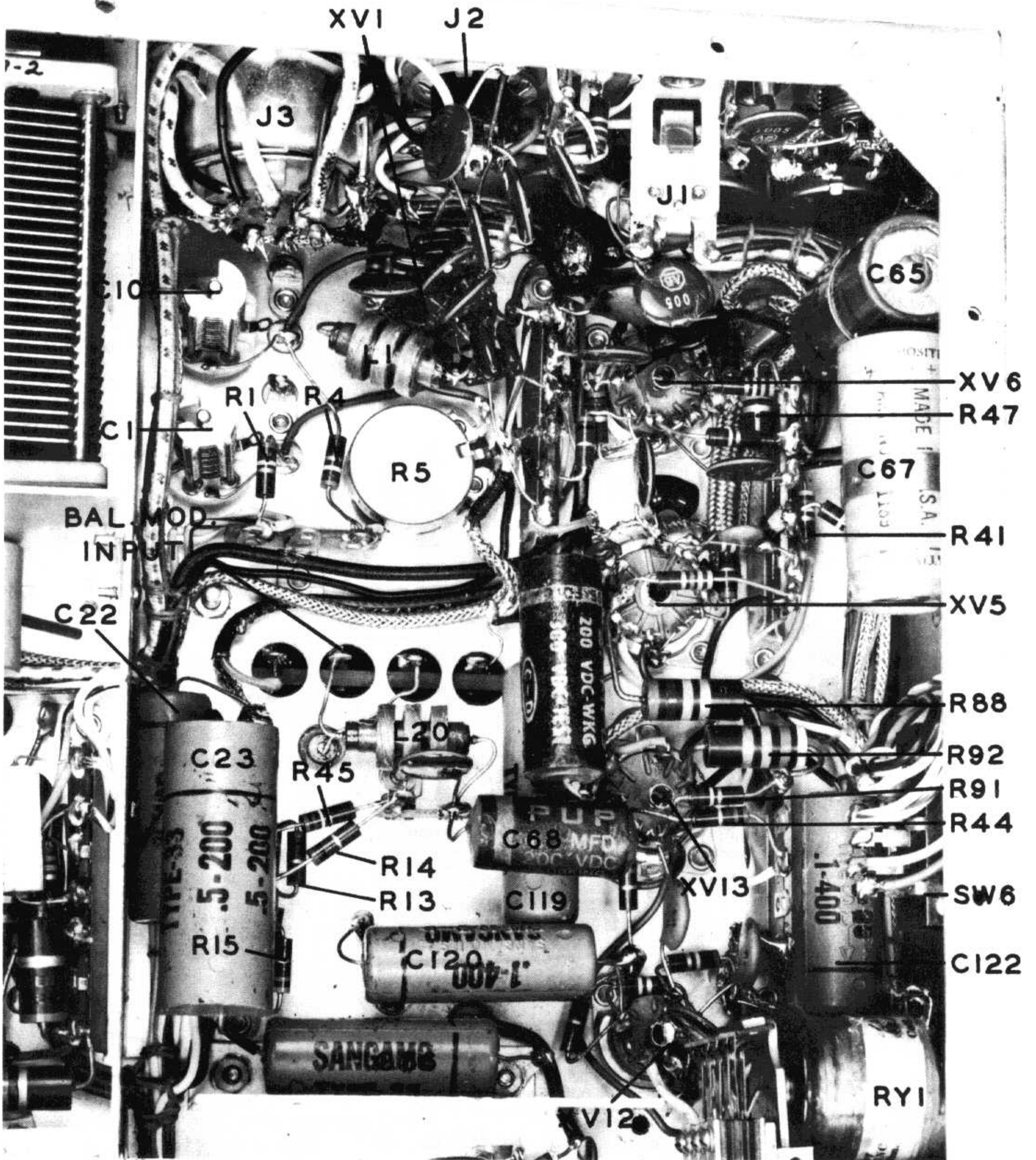

FIGURE 6.

BALANCED MODULATOR-AUDIO
 BOTTOM VIEW

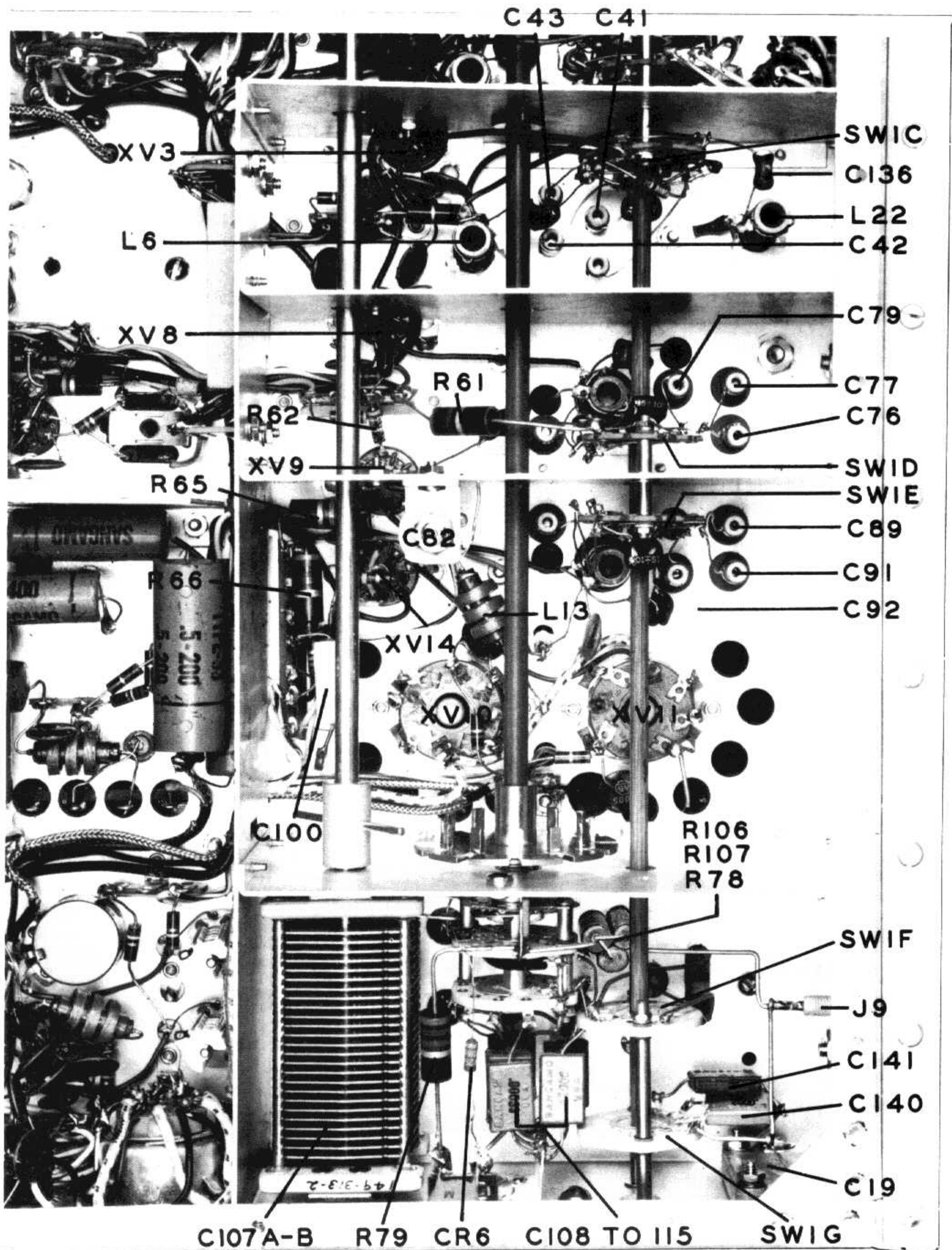

FIGURE 7.

RF EXCITER 6146 - BOTTOM VIEW

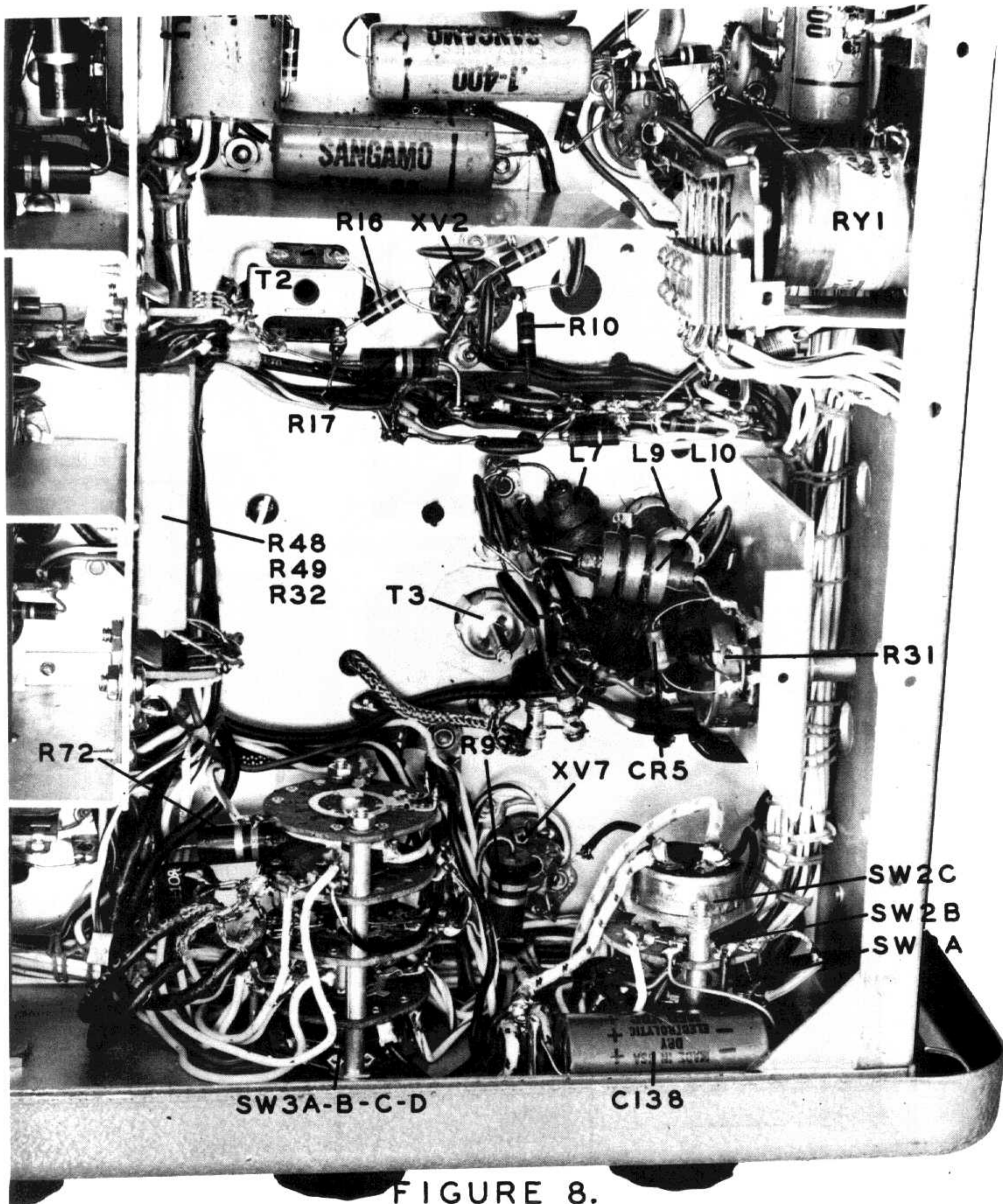

FIGURE 8.
SWITCH AREA-BOTTOM VIEW

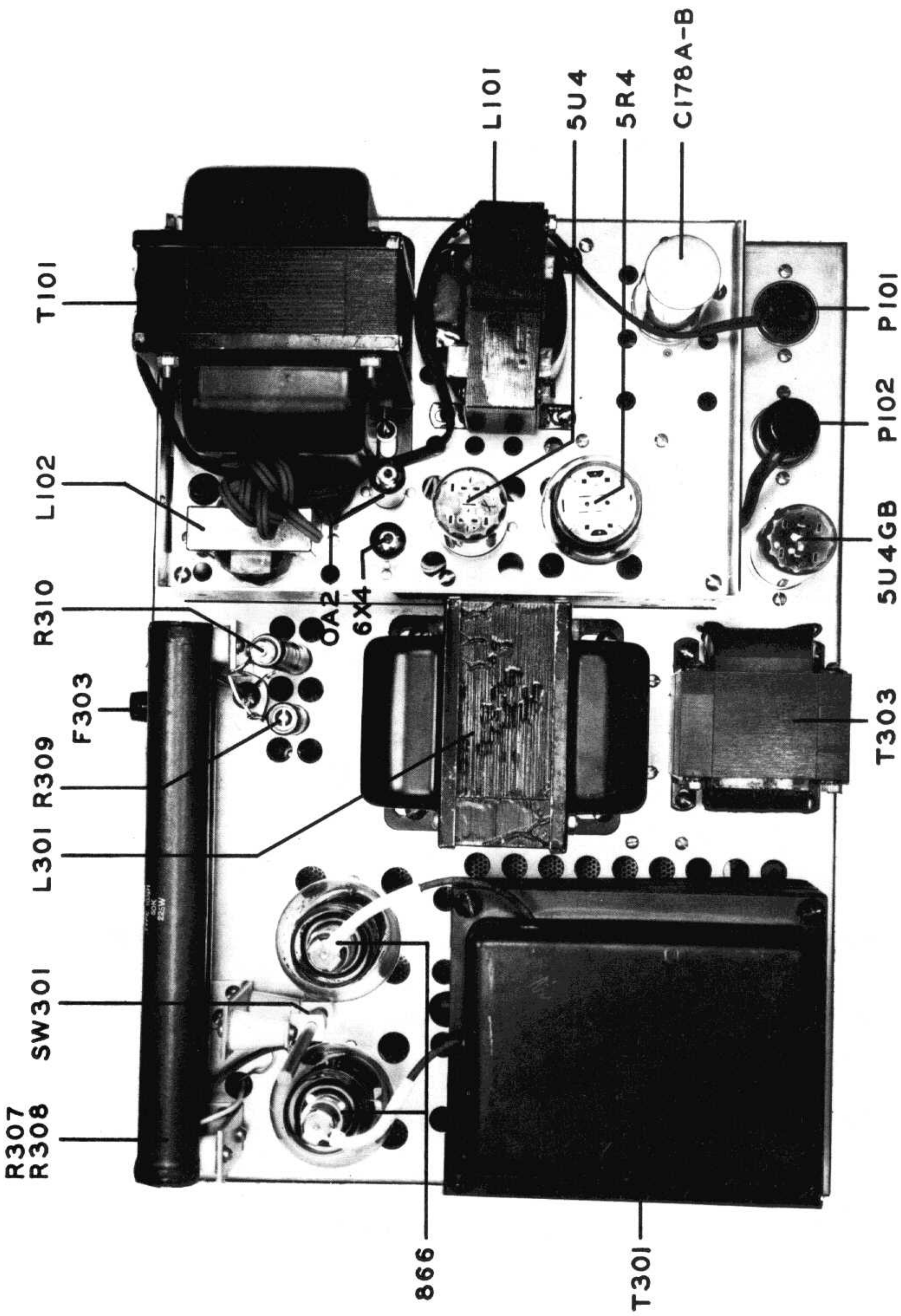

FIGURE 9 POWER SUPPLY-TOP VIEW

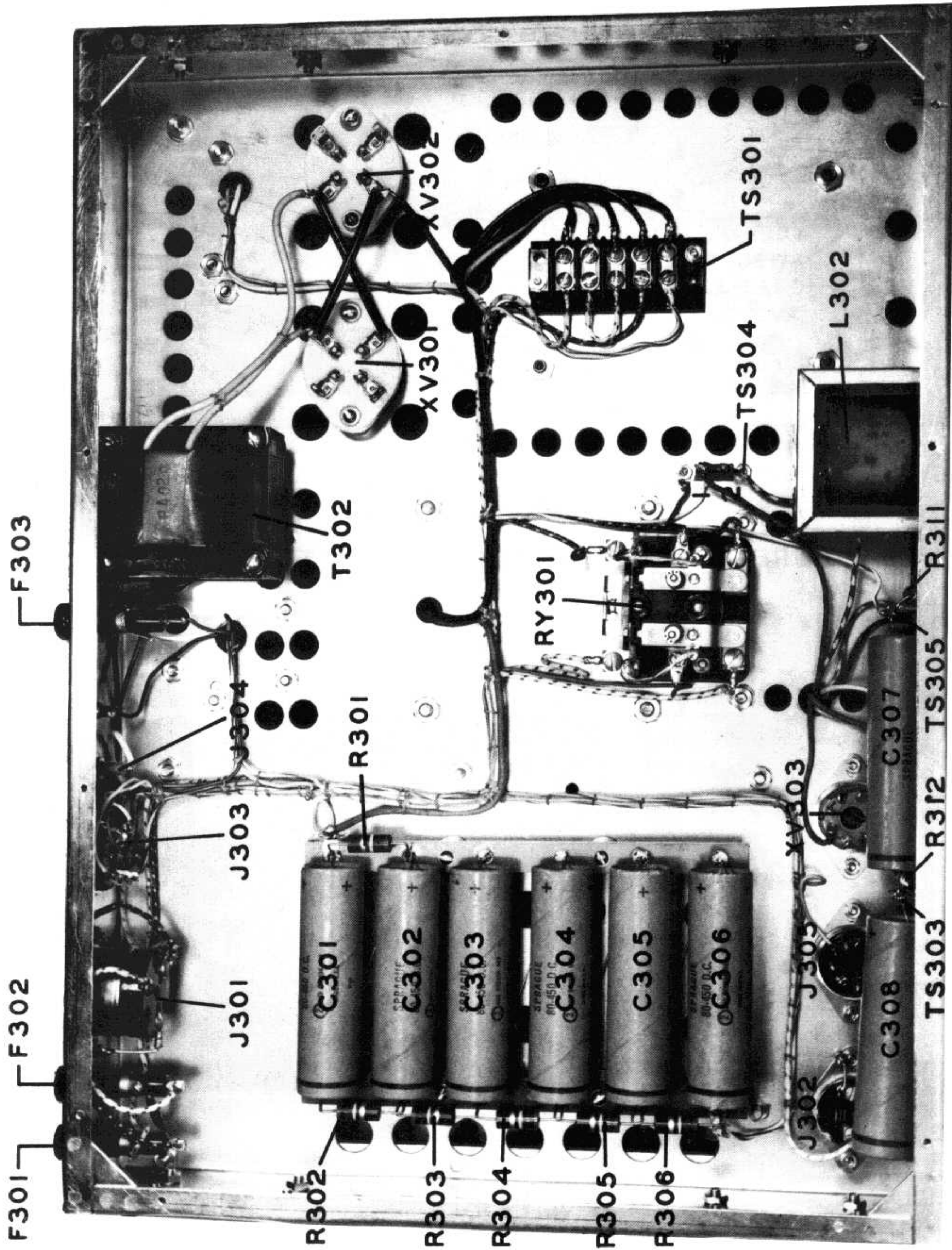

FIGURE 10 - POWER SUPPLY - BOTTOM

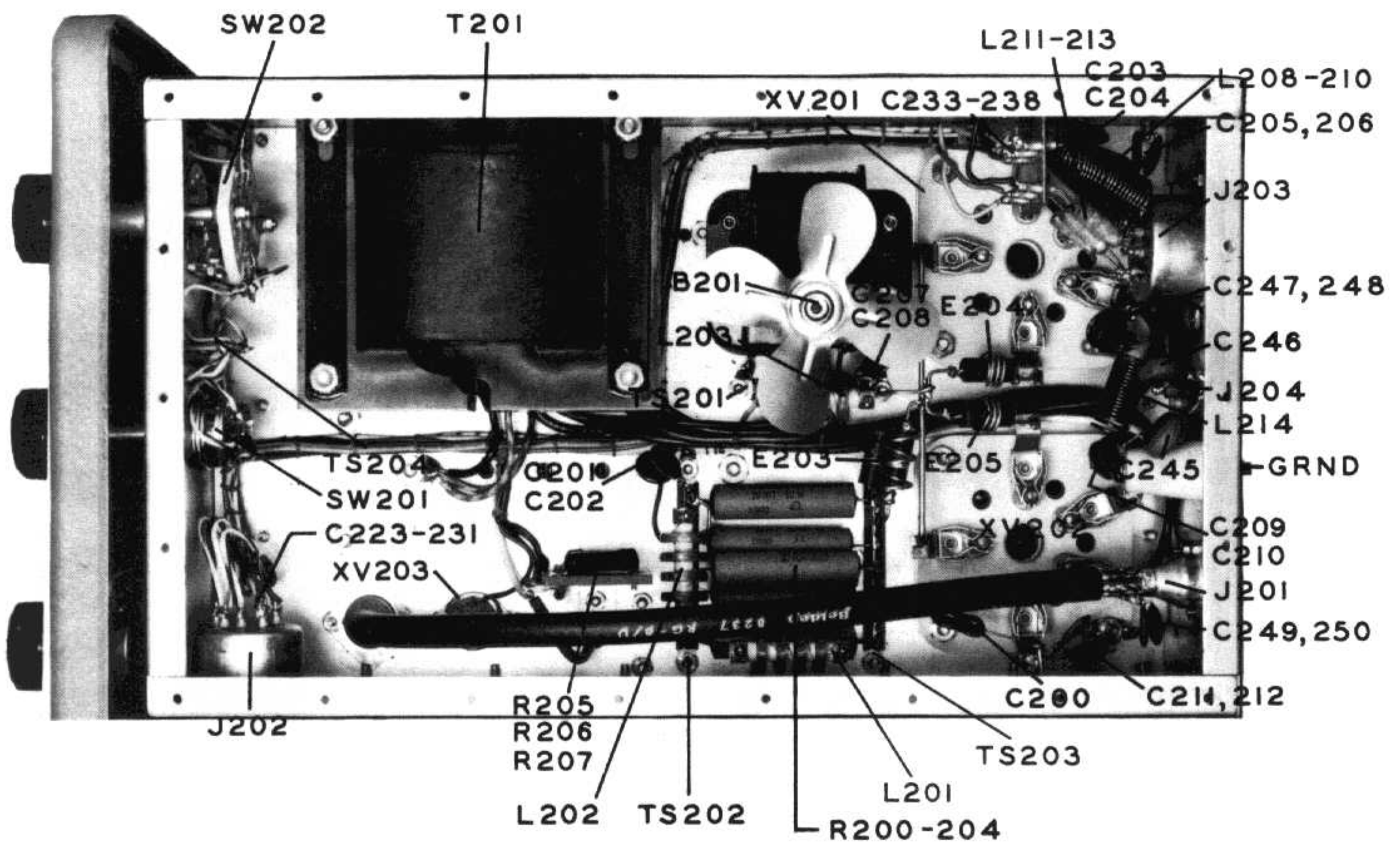

FIGURE IIA-POWER AMPLIFIER-BOTTOM

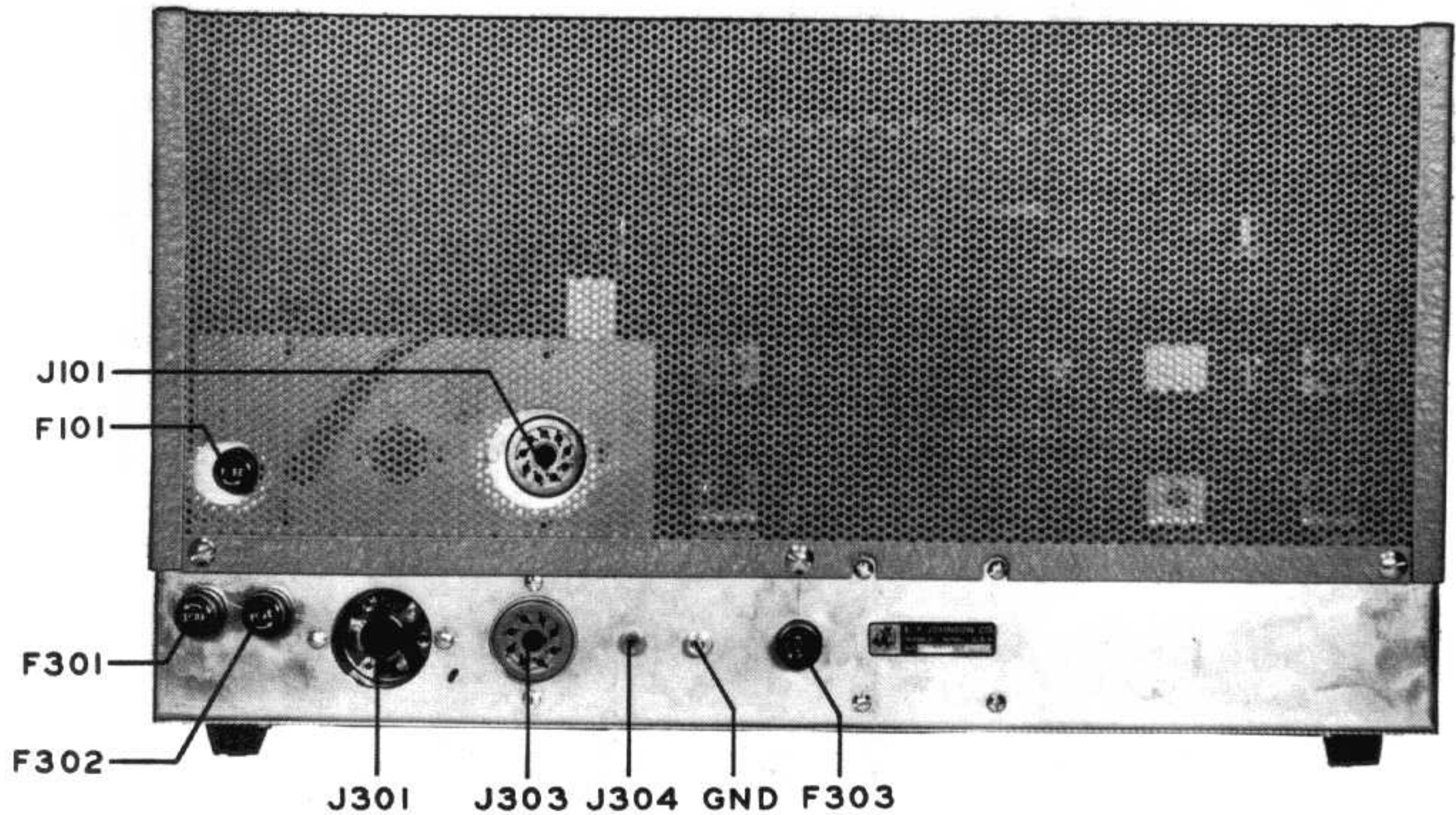

FIGURE IIB-POWER SUPPLY-REAR VIEW

Invader R. F. Voltage Measurements

Pin Numbers

	Tube Type	1	2	3	4	5	6	7	8	9
V1	12AU7			1.15					1.15	
V2	6AH6	0.5 at junction of R10 and R11				1.75				
V3	6CX8							1.0		1.45
V8	6AH6	0.9				1.65				
V9	12BY7		1.35					47		
V10	6146					45				
V11	6146					45				

Measurements made with V. T. V. M. with R. F. probe. Invader loaded to full output at 21.1 mc, CW; manual. Audio input - Zero.

Readings may vary + 20% due to tolerances. Line volts - 117 AC.

Invader Audio Voltage Measurements

Pin Numbers

	Tube Type	1	2	3	4	5	6	7	8	9
V5	12AT7	.15	2.65MV							
V6	12AT7	40.5	2.35			2.55		.145		
V12	6AL5	57	40					0.53		
V13	6U8	---	5.5			60			0.88	2.3

Measurements made with audio vacuum tube voltmeter. Audio input - 5MV at J6; VOX Gain full on. Audio Gain full on. 1.0 Volt at J2, Pin 1; A. T. Gain full on. Readings may vary ± 20% due to tolerances.

INVADER RESISTANCE MEASUREMENTS

	TUBE TYPE	PIN NUMBER								
		1	2	3	4	5	6	7	8	9
V1	12AU7	12K	100K	12.5	0.6	0.6	15K	100K	12.5	---
V2	6AH6	.53 Meg	---	0.12	---	22K	75K	---	---	---
V3	6CX8	220	10K	10K	0.45	---	270	47K	1 Meg	13K
V4	6AU6	100K	---	0.6	---	11K	9.5K	12.5	---	---
V5	12AT7	90K	1 Meg	---	---	---	22K	5 Meg	1500	0.1
V6	12AT7	360K	1.25 Meg	1200	---	---	250K	1.5 Meg	1200	0.1
V7	OA2	10K	---	---	---	10K	---	---	---	---
V8	6AH6	110K	---	0.1	---	13K	55K	---	---	---
V9	12BY7	---	50K	---	---	0.1	---	12.5K	15.5K	---
V10	6146	---	---	33K ‡	---	50K ‡	---	0.05	---	---
V11	6146	---	---	33K ‡	---	50K ‡	---	0.05	---	---
V12	6AL5	100K	1.05 Meg	0.1	---	5 Meg	---	1 Meg	---	---
V13	6U8	55K	3K	70K	---	0.1	240K	1.8K ‡	∞ - Oper-Off 1.8K Op-Man	---
V14	6T8	3.9K	0-AM, CW 1.35Meg-SSB	---	0.1	---	3.5 Meg	0-AM, CW 1.35 Meg-SSB	---	---
V101	5R4	---	300K	---	150	---	150	---	300K	---
V102	5U4	---	∞	---	20	---	20	---	∞	---
V103	6X4	∞ *	---	---	0.05	---	∞	1000	---	---
V104	OA2	---	*	---	*	---	---	---	---	---
J3					12K	13K	---	∞	---	---

Measurements made with 20,000 ohms/volt multimeter with respect to chassis ground.

Audio gain set to 10, RF Level and Zero Level to max C.C.W., VOX, ANTI-VOX and Time Delay to max. C.W., MODE to C.W., Band on 15, Power Line Plug Disconnected

Readings may vary ± 20% due to tolerances.

NOTE: * Normally gradually increasing resistance due to 100MF capacitor.
‡ Mode on LSB, Operate on Man.

INVADER VOLTAGE MEASUREMENTS

Tube Type	1	2	3	4	Pin Number 5	6	7	8	9
V1 12AU7	230	-18	.2	6 AC	6 AC	190	.08	.2	0
V2 6AH6	-.6	0	6 AC	0	220	125	0		
V3 6CX8	1.65	-7.5	150	5.8 AC	0	.53	-1.15	22	330
V4 6AU6	-5.7*	0	5.9 AC	0	150	145	.015		
V5 12AT7	52	-.48	0	0	0	175	---	3.8	6 AC
V6 12AT7	115	---	.95	0	0	70	---	.75	6 AC
V7 OA2	150				150		0		
V8 6AH6	-2 †	0	6 AC	0	300	120	0		
V9 12BY7	0	-2 †	0	0	0	6 AC	280	150	0
V10 6146	0	0	210	0	-68	0	6 AC	0	E plate 800
V11 6146	0	0	210	0	-68	0	6 AC	0	E plate 800
V12 6AL5	---	-34	6 AC	0	4		-30		
V13 6U8	200	0	180	0	6 AC	30	6.5	10	0
V14 6T8	-6.2	0	0	6 AC		.95	0		

Measurements made with 20,000 ohms/volt multimeter

Pri. Line Voltage 117 VAC

Invader loaded for max. output on 15 meters

CW Mode, manual operate, zero level to full C.W. position

Audio Input - .005V, VOX gain and audio at max

Readings may vary \pm 20% due to tolerances

* Read with VTVM

† Read on 10V scale



RESISTANCE VALUES ARE GIVEN IN OHMS UNLESS SHOWN OTHERWISE.
 CAPACITANCE VALUES ARE GIVEN IN MICRO-FARADS UNLESS SHOWN OTHERWISE.
 P.A. FILAMENT SWITCH SW201 IN "OFF" POSITION.
 P.A. PLATE SWITCH SW202 IN "TUNE" POSITION.
 P.A. LOADING SWITCH IN "MIN. CAPACITY" POSITION.

INVADER 2000
 AMPLIFIER AND POWER SUPPLY DIAGRAM

1-18-61

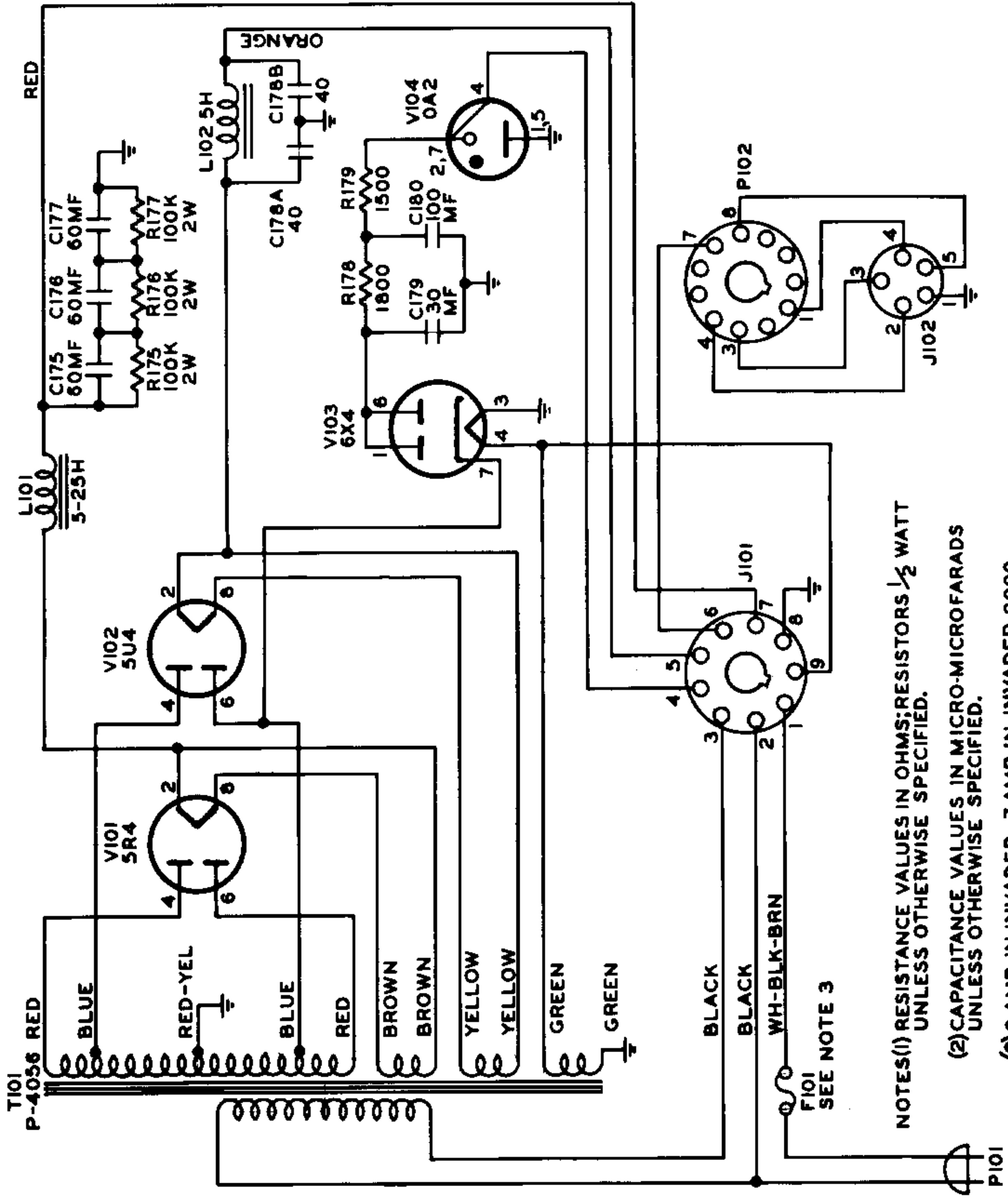

NOTES(1) RESISTANCE VALUES IN OHMS; RESISTORS $\frac{1}{2}$ WATT UNLESS OTHERWISE SPECIFIED.

(2) CAPACITANCE VALUES IN MICRO-MICROFARADS UNLESS OTHERWISE SPECIFIED.

(3) 6 AMP. IN INVADER, 7 AMP IN INVADER 2000









INVADER POWER SUPPLY SCHEMATIC DIAGRAM

FIGURE A
APPROXIMATE AMPLIFIER OPERATING VALUES

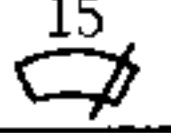
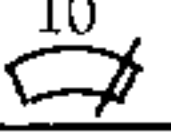
Vpr's = 230V	CW		AM LINEAR		TUNE	SSB	
	Trans.	Key Up	Trans.	With Block Bias	AM and SSB	Trans.	With Block Bias
Plate Voltage	2100	2450	2100	2450	2100	2100	2450
Screen Voltage	480	515	515	515	360	515	515
Bias Voltage	-75	-150	-75	-150	-75	-75	-150
Plate Current	475	0	385	0	290 to 370	300→475	0
Screen Current	85	0	5 to 10*	0	25	0→35*	0
Grid Current	10	0	2→5*	0	10	0→15*	0

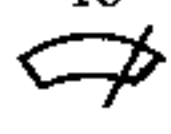
* On Voice Peaks Only

FIGURE B
APPROXIMATE DIAL POSITIONS
50 OHM LOAD

FREQUENCY, MCS.	4.0	7.3	14.35	21.45	29.7
Band Switch	80	40	20	15	10 HI
Loading Dial	AMP	AMP	AMP	AMP	AMP
Exciter Dial	80 	40 	20 	15 	10 
Amplifier Dial	74	22	72	80	78
Power Amplifier Dial	80 	40 	20 	15 	10 
PWR AMP Loading Switch	3	4	5	5	5
PWR AMP Loading Variable Capacitor For CW	3.0	2.5	1.6	3.0	3.75
PWR AMP Loading Variable Capacitor for Linear AM or SSB	6.0	5.0	2.5	3.5	4.0

LOWER POWER OPERATION
APPROXIMATE DIAL POSITIONS
50 OHM LOAD

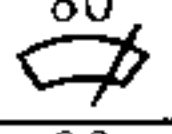
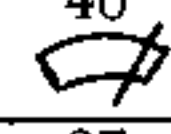
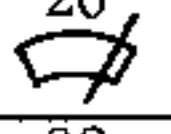
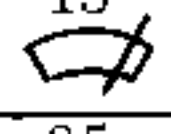
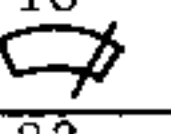
FREQUENCY, MCS.	4.0	7.3	14.35	21.45	29.7
Band Switch	80	40	20	15	10 HI
Exciter Dial	80 	40 	20 	15 	10 
Amplifier Dial	83	37	82	85	83
Loading Dial *	5 - 4	8 - 2	9 - 1.5	9 - 2	9 - 1.5

* The first number is the loading number shown in the panel window and the number after the - is the dial setting.

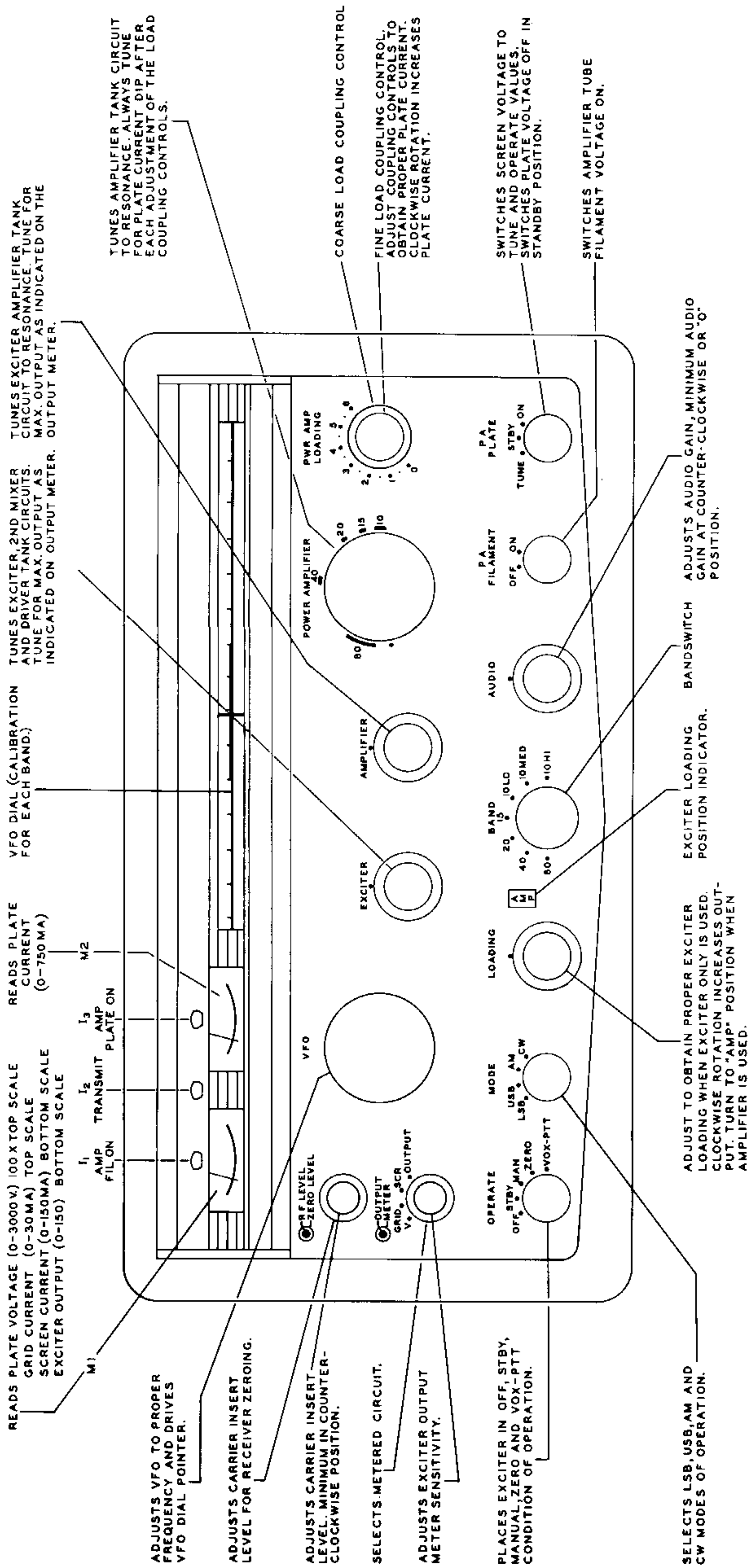

FIGURE C

FRONT PANEL CONTROL FAMILIARIZATION CHART

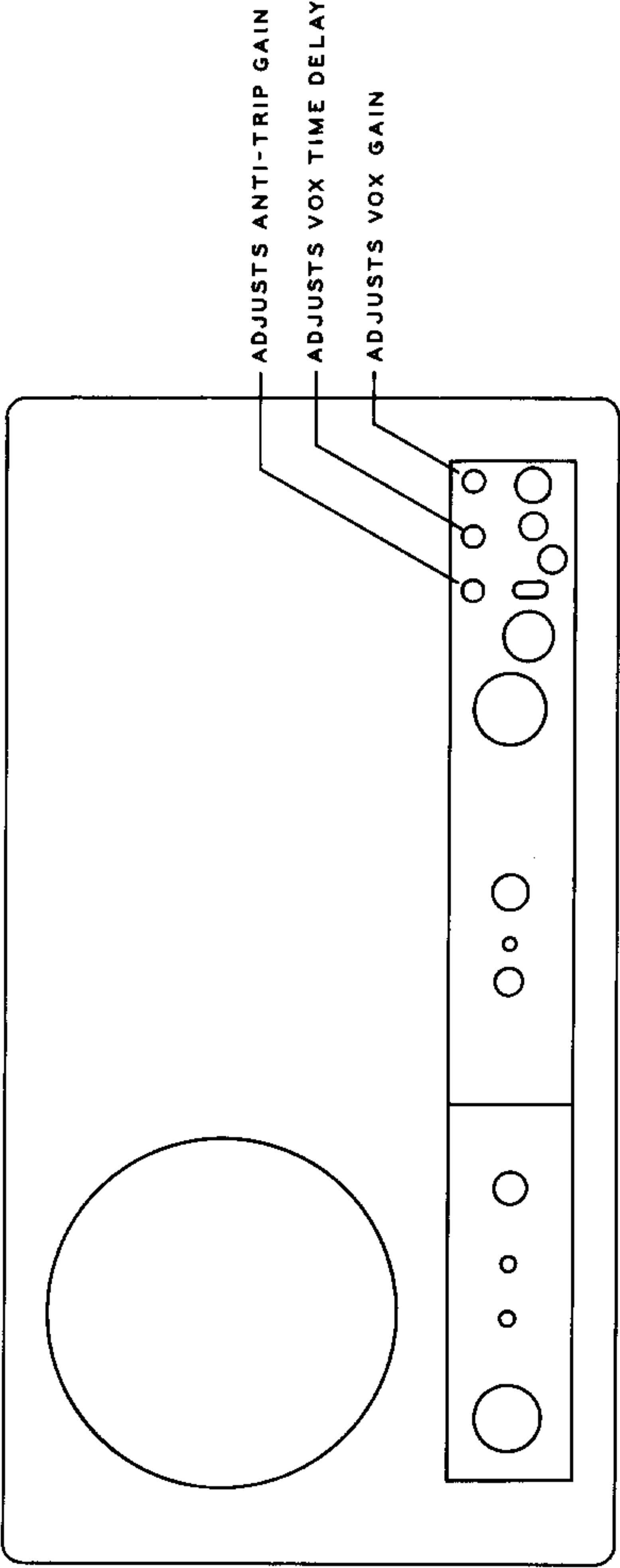

FIGURE D
REAR CHASSIS CONTROL FAMILIARIZATION
CHART

VIKING INVADER

Parts List

Part No. or Drawing No.	Item No.	Qty.	Description
22.4018-5	C75, 90	2	5 mmfd + 5% Durmica capacitor
160-130-52	C1, 10, 52	3	3-32 mmf variable air capacitor
22.4029-5	C2, 6, 8, 74	4	15 mmf + 5% Durmica capacitor
22.4045-5	C3, 7, 31	3	68 mmf + 5% Durmica capacitor
22.827	C4, 9, 15, 16, 17, 18, 21, 24, 25, 26, 32, 33, 34, 35, 37, 45, 46, 56, 57, 64, 66, 69, 70, 83, 96, 97, 98, 99, 116, 117, 124, 125, 126, 127, 128, 129, 130, 131, 132, 137, 142, 143, 145, 146	44	.005 mf GMV 600 V ceramic disc capacitor
22.4183-5	C12, 71	2	2200 mmf + 5% Durmica capacitor
160-130-23	C13	1	3-32 mmf variable air capacitor
22.4041-5	C14	1	47 mmf + 5% Durmica capacitor
22.1184	C20, 147, 148	3	1000 mmf + 20% disc ceramic capacitor
22.1709	C22, 86, 100, 120	4	.1 mf 200 V paper capacitor
22.1409	C23	1	.5 mf + 20% 200 V paper capacitor
22.1514	C27, 28, 29, 77, 87, 91	6	1-7.5 mmf ceramic variable capacitor
22.4421-10	C30	1	1 mmf composition capacitor
22.4041-5	C36	1	47 mmf + 5% Durmica capacitor
22.4029-5	C39	1	15 mmf + 5% Durmica capacitor
22.4055-5	C44	1	180 mmf + 5% Durmica capacitor
22.4049-5	C5, 47	2	100 mmf + 5% Durmica capacitor
22.1770	C48, 49	2	400 mmfd + 2% silver mica CM20D capacitor
22.1759	C144	1	15N220 + 5% ceramic capacitor
167-151-12	C51	1	100L15 variable air capacitor
22.1710	C53	1	22 mmf + 5% NPO ceramic capacitor
22.1711	C54	1	22 mmf + 5% N750 ceramic capacitor
160-311-52	C55	1	19MA11 differential variable air capacitor
22.1184	C58	1	1000 mmf + 20% ceramic disc capacitor
22.4061-5	C59, 60	2	330 mmf + 5% Durmica capacitor
22.1130	C61	1	5-35 mmf ceramic variable capacitor
22.1300	C63	1	2000 mmf + 20% 600 V ceramic disc capacitor
22.1712	C65	1	100 mf 25 V electrolytic capacitor
22.1189-2	C67	1	8 mf 450 V electrolytic capacitor
22.1581	C68	1	1 mf 200 V capacitor
22.4062-5	C38	1	360 mmfd + 5% Durmica capacitor
22.4061-5	C62, 72	2	330 mmf + 5% Durmica capacitor
22.4035-5	C78, 93	2	27 mmf + 5% Durmica capacitor
22.1714	C40, 41, 42, 43, 73, 76, 79, 89, 92	9	3-21 mmf ceramic variable capacitor
22.4039-5	C80, 94	2	39 mmf + 5% Durmica capacitor
160-102-52	C82	1	5M11 variable air capacitor
22.4175-10	C85	1	1000 mmf + 10% Durmica capacitor
148-103-55	C88	1	9S30 variable air capacitor with bracket
22.956	C101, 102	2	2000 mmf GMV 1500 V ceramic disc capacitor
149-907-2	C103	1	100-15ORD12 dual air variable capacitor
22.1139	C104, 105	2	300 mmf + 10% V mica capacitor
22.1097	C106, 118, 121, 139	4	.01 mf $\begin{matrix} +80\% \\ -20\% \end{matrix}$ ceramic disc capacitor
149-313-2	C107	1	36ORA12 differential air variable capacitor

VIKING INVADER

Parts List

Part No. or Drawing No.	Item No.	Qty.	Description
22.1297	C108, 109, 110, 111 112, 113, 114, 115	8	330 mmf \pm 5% 500 V mica capacitor
22.1026	C119	1	.22 mf 200 V paper capacitor
22.768	C122	1	.1 mf 400 V paper capacitor
22.1484	C123	1	2 mf 200 V paper capacitor
22.4057-5	C134	1	220 mmf \pm 5% Durmica capacitor
22.4041-5	C135	1	47 mmf \pm 5% Durmica capacitor
22.1132	C136	1	3 mmf ceramic capacitor
22.1750	C84	1	1000 mmf ceramic feed-thru capacitor with mtg. nut
22.1744-1	C138	1	12 mf 150 V electrolytic capacitor
22.1771	C19	1	150 mmf \pm 10% 1200 V mica capacitor
22.858-1	C140	1	200 mmf \pm 5% 500 V mica capacitor
22.1508	C141	1	680 mmf \pm 10% 1500 V mica capacitor
22.1760	C50	1	25 mmf \pm 5% N750 ceramic disc capacitor
22.4051-5	C11, 81, 95	3	120 mmf \pm 5% Durmica capacitor
17.1145-2	CH1	1	Chassis
23.1457-2	CH2	1	Cabinet
23.1127-11	CH3	1	Panel
17.853-2	CH4	2	Chassis rails
17.1132-3	CH5	1	End shield plate
17.1132-1	CH6	1	Mixer shield plate
17.1132-2	CH7	1	Driver shield plate
17.1132-4	CH8	1	Grid shield plate
23.1510	CH9	1	Side shield plate, riveted assembly
16.1459	CH10	1	Coil plate (VFO)
23.1408	CH11	1	VFO enclosure assembly
23.1490	CH12	1	VFO front plate, staked
23.1400	CH13	1	P.A. shield assembly
17.1147	CH14	1	Front filter shield
17.1165	CH15	1	Mounting J4 11 pin socket
23.1417	CH16	1	Enclosure, balanced modulator
23.1486	CH18	1	VFO shield can assembly
17.1158	CH19	1	VFO side shield
17.1156	CH20	1	VFO bottom cover
18.775	CH21	1	Coil mtg. base
17.1144	CH22	1	Slug rack frame
23.1418	CH23	1	VFO filter can assembly
22.1085-2	CH24	1	Socket shell
17.1164	CH25	1	Meter bracket
23.1399	CH26	1	Wheel assembly
23.1456	CH27	1	Drive assembly
17.1162-3	CH28	1	Overlay panel
23.1504	CH29	1	Trim and pin assembly
22.1475-2	CH30	4	Plastic feet
17.1170	CH31	1	Bottom plate
17.1167	CH32	1	Rear panel cover
18.790	CH33	1	Fiber terminal strip cover
22.1413	CR1, 2, 3, 4, 5, 6	6	1N294 germanium diode
23.1491	D1	1	VFO shaft extension (1 1/2") assembly with nylon pulley
18.784	D2	1	Shaft, insulated (bandswitch) 12 1/2"

VIKING INVADER

Parts List

Part No. or Drawing No.	Item No.	Qty.	Description
18.751-5	D3	1	Shaft loading indicator insulated 9 7/8"
14.139-11	D4	1	Shaft, loading capacitor, 10 1/2"
13.123-12	D5	4	Panel bearings
18.666-4	D7	1	Coupling rigid, insulated, less setscrews (1/4 to 1/4)
115.253-22	D8	1	Shaft and flexible shaft assembly
104-264-3	D9	2	Coupling flexible, ins. less setscrews (3/16 to 1/4)
22.1272	D10	1	Bead chain spring
22.1737-2	D11	1	Dial window
23.1455	D12	1	Gear assembly (exciter tuning)
23.1492	D13	1	Dial drum assembly
17.1163	D14	1	Pointer guide bkt.
17.1169	D15	1	Right dial support
17.1168	D16	1	Left dial support
22.1137-4	D17	1	Dial pointer
23.1497-2	D18	1	Escutcheon assembly
16.1482	D19	1	Torsion spring
22.1169	D20	1	Spring pulley
23.1160-3	D21	1	1 1/4" string drive assembly
22.1708	D22	3	Bead chain pulleys
13.155-132	D24	1	Spacer, bead chain pulley, small
13.155-133	D26	1	Spacer, bead chain pulley, large
13.578-5	D27	1	Spacer, drum pulley
13.155-112	D28	1	Spacer, plastic pulley
13.155-134	D29	2	Spacers, pointer guide
14.31-3	D30	2	Standoffs, 6-32 1.540 long
13.49-36	D31	2	Spacers, P.A. capacitor, 9/16"
16.1479	D32	1	Strap, P.A. neut.
16.1473	D33	2	Springs, hold down
17.1137	D34	1	Bearing bracket (VFO)
23.1409	D35	1	Gear and hub assembly (VFO)
23.1460	D36	1	Gear and shaft assembly (VFO)
13.991	D37	2	Spacers, VFO gear bracket
13.155-128	D38	2	Spacers, plug mtg. plate 3/16"
22.1698	D39	1	Detent, bandswitch
13.49-9	D40	2	Spacers, loading capacitor, 1/2"
23.1487	D41	1	Indicator, loading assembly
23.1496	D42	1	Indicator, exciter tune assembly
13.155-129	D43	10	Spacers, switch, 11/32" long
13.155-130	D44	2	Spacers, switch, 5/8"
13.155-131	D45	2	Spacers, switch, 1"
17.1143	D46	2	Slug rack arm
13.992	D47	2	Slug holders
13.993	D48	1	Slug rack shaft
31.485	D49	4	Bearings, 1/8 dia. ball
31.416	D50	1	Bearing, 5/32 dia. ball
13.46-1	D51	2	Bearings, adjusting screw
116-223-11	D52	2	Knob, 1 1/8 with pointer
23.1493-1	D53	2	Knob, 1 1/8 with pointer and .266 dia. thru hole
13.1006	D54	2	Knob, aluminum, 3/16 shaft hole
23.1463	D55	1	Knob, 2 3/8 with alum, insert

VIKING INVADER

Parts List

Part No. or Drawing No.	Item No.	Qty.	Description
23.907-22	D56	1	Knob, 1 1/8 with 1 1/2 skirt, 100 to 0 over 180°
23.907-13	D57	1	Knob, 1 1/8 with 1 1/2 skirt, 10 to 0
116-263-11	D58	1	Knob, 1 5/8 with pointer
23.1498	D59	1	Knob, 1 1/8, .093 shaft
18.783-1	D60	1	Jewel, clear
18.783-4	D61	1	Jewel, amber
18.783-2	D62	1	Jewel, red
22.920-1	D63	3	Knob, black plastic
23.1493-2	D64	1	Knob, 1 1/8 without pointer, with 1/4" thru hole
23.907-29	D65	1	Knob, 1 1/8 with 1 1/2 skirt, 0-5-0 over 360°
17.1174	D66	2	Retaining clip
22.1715-1	D67	1	Bead chain
22.1758	D68	1	Bearing, nylon
13.123-14	D69	1	Panel bearing
104-264-6	D70	1	Coupling, flexible, insulated (3/16 to 1/4)
16.1416-2	D71	1	VFO cover contact spring
23.1495	E1	1	Parasitic suppressor assembly
22.1210-1	E3, 4, 5, 6, 7	5	.245 x 1/2 powdered iron cores
22.1210-3	E8, 9, 12	3	.370 x 5/8 powdered iron cores
22.1733	E10, 11	2	Powdered iron cores with studs and spring inserts
22.1256	F1	1	Fuse, 6 amp. MTH (Use 7 amp. in Invader 2000)
22.1772	FL1	1	9MC crystal filter
22.1246	J1	1	Key jack shorting type
22.1585	J2	1	5 pin Amphenol socket
22.1365-15	J3	1	9 pin male socket with mtg. ring
22.1677-1	J4	1	11 pin female socket with mtg. ring
22.979	J6	1	2 pin microphone jack with shakeproof and nut
22.1096	J7	1	Phono type jack
22.746	J8	1	Coaxial connector 83R1
105-804-3	J9, TPI	2	Nylon phone tip jack
22.1193	L1, 5, 7, 10, 13, 20	6	2.4 MH 4 pi choke
22.1175-2	L6	1	.29 uh coil
23.1175-30	L3	1	13 uh coil
22.1644-1	L4	1	.22 uh coil
23.1175-27	L8	1	2.4 uh VFO coil
23.1175-9	L9, 22	2	9.65 uh coil
23.1404	L11, 12	2	2.6 uh coil
102-752-4	L14	1	RF choke 1 MH
23.1489	L15	1	PA 10-15 meter coil
23.1461	L16	1	PA 80-40-20 meter coil
22.844-3	L17, 18, 19	3	500 uh RFC
23.1175-4	L21	1	1.26 uh coil
22.1689	M1	1	Meter with hardware
22.5113-10	R85	1	470K ohm \pm 10% 1/2 W resistor
22.5119-10	R1, 4	2	820K ohm \pm 10% 1/2 W resistor
22.5097-10	R2, 3, 30, 84, 90, 12	6	100K ohm \pm 10% 1/2 W resistor
22.1786	R5	1	10K ohm \pm 30% 1/2 W potentiometer
22.5073-10	R22, 53, 68	3	10K ohm \pm 10% 1/2 W resistor
22.5039-10	R9	1	390 ohm \pm 10% 1/2 W resistor
22.5067-10	R10, 11	2	5600 ohm \pm 10% 1/2 W resistor
22.5121-10	R13, 14, 20, 35, 37, 69, 86, 46, 57, 67	10	1 megohm \pm 10% 1/2 W resistor

VIKING INVADER

Parts List

Part No. or Drawing No.	Item No.	Qty.	Description
22.5133-10	R15	1	3.3 megohm + 10% 1/2 W resistor
22.5089-10	R16, 18, 58, 59, 60 63, 92	7	47K ohm + 10% 1/2 W resistor
22.6073-10	R17	1	10K ohm + 10% 1 watt resistor
22.5035-10	R19	1	270 ohm + 10% 1/2 W resistor
22.5033-10	R21, 24	2	220 ohm + 10% 1/2 W resistor
22.6049-10	R23	1	1000 ohm + 10% 1 watt resistor
22.5037-10	R89, 26	2	330 ohm + 10% 1/2 W resistor
22.5041-10	R7	1	470 ohm + 10% 1/2 W resistor
22.5017-10	R62, 25	2	47 ohm + 10% 1/2 W resistor
22.5049-10	R28, 29	2	1000 ohm + 10% 1/2 W resistor
22.1720	R31, 94, 8	3	200 ohm + 30% 1/4 W potentiometer
22.8908-10	R32	1	15K 10 watt wirewound resistor
22.5059-10	R33	1	2700 ohm + 10% 1/2 W resistor
22.5065-10	R34	1	4700 ohm + 10% 1/2 W resistor
22.5091-10	R36	1	56K ohm + 10% 1/2 W resistor
22.5051-10	R39, 81	2	1200 ohm + 10% 1/2 W resistor
22.5105-10	R40, 91, 104	3	220K ohm + 10% 1/2 W resistor
22.5113-10	R96	1	470K ohm + 10% 1/2 W resistor
22.1195	R43, 80	2	1 megohm + 30% 1/4 W log taper potentiometer
22.5055-10	R44, 93, 41	3	1800 ohm + 10% 1/2 W resistor
22.5117-10	R45	1	680K ohm + 10% 1/2 W resistor
22.6083-10	R47	1	27K ohm + 10% 1 W resistor
22.8886-10	R48	1	1800 ohm + 10% 10 W resistor
22.8887-10	R49	1	2000 ohm + 10% 10 W resistor
22.1115	R71	1	100K ohm + 30% 1/3 W potentiometer
22.1694	R51, 52	1	Dual 100K ohm + 30% 1/4 W potentiometer
22.5111-10	R56	1	390K ohm + 10% 1/2 W resistor
22.7049-10	R61	1	1000 ohm + 10% 2 W resistor
22.7087-10	R64	1	39K + 10% 2 W resistor
22.1818	R109	1	25K ohm + 10% 1/3 W potentiometer
22.7073-10	R65, 72, 97	3	10K ohm + 10% 2 W resistor
22.5061-10	R73	1	3300 ohm + 10% 1/2 W resistor
22.5025-10	R74, 75, 101, 27	4	100 ohm + 10% 1/2 W resistor
22.5095-10	R76	1	82K ohm + 10% 1/2 W resistor
22.5063-10	R6, 77	2	3900 ohm + 10% 1/2 W resistor
22.5069-10	R98	1	6800 ohm + 10% 1/2 W resistor
22.7051-10	R79	1	1200 ohm + 10% 2 W resistor
22.5109-10	R82	1	330K ohm + 10% 1/2 W resistor
22.1693	R83	1	5 megohm + 30% 1/4 W potentiometer
22.5053-10	R87	1	1500 ohm + 10% 1/2 W resistor
22.7095-10	R8 8	1	82Kohm + 10% 2 W resistor
22.5083-10	R95, 70	2	27K ohm + 10% 1/2 W resistor
22.1753	R99	1	3.3 ohm + 2% 1/2 W wirewound resistor
22.1752	R100	1	.68 ohm + 2% 1/2 W wirewound resistor
P/OSW5	R102	1	50K + 30% 1/4 W potentiometer
22.5065-10	R103	1	4700 ohm + 10% 1/2 W resistor
22.832	R50	1	1 megohm + 30% 1/4 W potentiometer
22.7081-10	R78, 106, 107	3	22K ohm + 10% 2 W resistor
22.5041-10	R108	1	470 ohm + 10% 1/2 W resistor
22.8880-10	R105	1	1000 ohm + 10% 10 W resistor

VIKING INVADER

Parts List

Part No. or Drawing No.	Item No.	Qty.	Description
22.8680-10	R66	1	1000 ohm + 10% 5 W resistor
22.1214	RY1	1	Relay, 4 PDT sensitive
22.1700	SW2	1	Operate switch, 2 section phenolic, with switch
22.1415	SW6	1	Ext.-Int. Amp. Switch, 3 PDT slide switch
22.1699	SW3	1	Mode switch, 4 section phenolic
22.1696	SW4	1	Loading cap. switch, 2 section ceramic
22.1695	SW5	1	Meter switch, one section phenolic, with R-102
22.1697-1	SW1A	1	Switch section phenolic
22.1697-2	SW1B	1	Switch section phenolic
22.1697-3	SW1C	1	Switch section phenolic
22.1697-4	SW1D	1	Switch section phenolic
22.1697-5	SW1E	1	Switch section phenolic
22.1697-6	SW1F	1	Switch section ceramic
22.1697-7	SW1G	1	Switch section ceramic
22.1722	T2	1	9 mc. I. F. transformer
23.1422	T3	1	VFO filter
22.1723	T4	1	Anti-trip input transformer
23.1423	T1	1	Toroid coil assembly
23.1502-1	T5	1	22.5 mcs. trap assembly
22.837	TS6, 17, 18, 19, 20	5	2 terminal strips
22.1401-1	TS1, 2	2	3 terminal strip, 1 ground
22.740-3	TS14	1	3 terminal strip
22.740-4	TS8, 10, 13, 15	4	4 terminal strip
22.740-5	TS5, 7	2	5 terminal strip
22.740-6	TS3, 4	2	6 terminal strip
22.740-7	TS16	1	7 terminal strip
22.740-8	TS9	1	8 terminal strip
22.740-2	TS11, 12	2	2 terminal strip
22.916	V1	1	12AU7 electron tube
22.1724	V2, 8	2	6AH6 electron tube
22.1725	V3	1	6CX8 electron tube
22.780	V4	1	6AU6 electron tube
22.1203-2	V5, 6	2	ECC-81 12AT7 electron tube
22.787	V7	1	OA2 electron tube
22.1567	V9	1	12BY7 electron tube
22.788	V10, 11	2	6146 electron tube
22.786	V12	1	6AL5 electron tube
22.1323	V13	1	6U8 electron tube
22.1726	V14	1	6T8 electron tube
23.1507	W1	1	Cable, P.S. to exciter including 1 male and 1 female plug
23.1501	X14, 5, 6, 9	1	Pilot lamp socket assembly
23.1500	X8, 17	1	Pilot lamp socket assembly
22.1207	XV1, 3, 9	3	9 pin miniature shielded sockets
22.1208	XV2, 4, 8	3	7 pin miniature shielded sockets
22.976	XV5, 6, 13, 14	4	9 pin miniature sockets
22.975	XV7, 12	2	7 pin miniature sockets
22.1274	XV10, 11	2	Octal sockets MIP
22.1218-1	XS1, 3, 9	3	9 pin tube shield
22.1218-2	XS2, 4, 8	3	7 pin tube shield
126-105	XY1, 2, 3, 4, 5, 6, J5	7	2 pin ceramic crystal sockets
22.1773	Y1	1	9001.5 kc crystal
22.1774	Y2	1	8998.5 kc crystal

VIKING INVADER

Parts List

<u>Part No. or Drawing No.</u>	<u>Item No.</u>	<u>Qty.</u>	<u>Description</u>
22.1727	Y3	1	25.6 MC crystal
22.1728	Y4	1	24.5 MC crystal
22.1729	Y5	1	25 MC crystal
22.1730	Y6	1	21.5 MC crystal
23.1488	Z1	1	Balanced modulator assembly

VIKING INVADER POWER SUPPLY

Parts List

<u>Part No. or Drawing No.</u>	<u>Item No.</u>	<u>Qty.</u>	<u>Description</u>
23.1419	CH1	1	Chassis
22.1387	C175, 176, 177	3	Capacitor, filter electrolytic 450 v 60 uf.
22.1702	C178A, B	1	Capacitor, filter, dual 40 MFD, 450 VDC
22.962-1	C179	1	Capacitor, filter, 30 MFD, 450 VDC
22.1187	C180	1	Capacitor, filter, 100 MFD, 250 VDC
22.739-2	FH101	1	Post, fuse extractor
22.1170	G1	1	Grommet, 3/4" O.D. x 7/16 I.D. x 1/4 thick, 9/16 hole
22.925	G2, 3	2	Grommet, 1/2" O.D. x 1/4" I.D.
22.1655	G4	1	Bushing, line cord strain relief
22.977	J101	1	Socket, noval female
22.1585	J102	1	Socket, 5 pin miniature female
22.1705	L101	1	Choke, filter, 5-25 henry HV
22.1706	L102	1	Choke, filter, 5 henry LV
22.741	P101	1	Cord, line
22.9086-10	R178	1	Resistor, 1800 ohms, 7 watt, W.W., PW-7
22.9084-10	R179	1	Resistor, 1500 ohms, 7 watt, W.W., PW-7
22.8911-5	R175, 176, 177	3	Resistor, 20K.ohms, 10 watt W.W., PW-10
22.1686	T101	1	Transformer, H. V. power
22.837	TS1, 2	2	Terminal strip, two terminal
22.784	V101	1	Tube, electron type 5R4GY
22.1104	V102	1	Tube, electron type 5U4G
22.1366	V103	1	Tube, electron type 6X4
22.787	V104	1	Tube, electron type OA2
22.1274	XV101, 102	2	Socket, molded octal
22.975	XV103, 104	2	Socket, seven pin miniature
22.8880-10	R180	1	Resistor, 1000 ohm \pm 10%, 10 watt W.W.

VIKING INVADER 2000 HIGH POWER AMPLIFIER

Parts List

<u>Part No. or Drawing No.</u>	<u>Item No.</u>	<u>Qty.</u>	<u>Description</u>
22.1079	B201	1	Motor, 115 volt, 60 cycle AC
23.1421	B202	1	Exhaust fan and shield assembly
22.1684	B203	1	Blade, 3" fan

VIKING INVADER 2000 HIGH POWER AMPLIFIER

Parts List

Part No. or Drawing No.	Item No.	Qty.	Description
17.752-4	BKT201	1	Bracket, final tank mounting
17.754-12	BKT202	1	Bracket, final tuning capacitor mounting
16.1448	BKT203	1	Bracket, loading capacitor and choke mtg.
22.4289-10	C200	1	Capacitor, .0047 mf mica
22.827	C201, 202, 205, 206, 209, 210, 247, 248, 249, 250	10	Capacitor, .005 mf 600 VW ceramic disc
22.828	C203, 204, 207, 208, 211, 212	6	Capacitor, .001 mf 1500 VW ceramic disc
22.1112	C213, 214	2	Capacitor, .0005 mf 20 KV ceramic
22.1506	C215, 245, 246	3	Capacitor, .0005 mf 6 KV ceramic disc
154-38-3	C216	1	Capacitor, variable 320 E 30
154-40-3	C217	1	Capacitor, variable 700 E 15
22.1458	C218, 219	2	Capacitor, .0003 mf 2500 VW mica
22.1427	C220, 221, 222	3	Capacitor, .00062 mf 2500 VW mica
22.1610	C223, 224, 225, 226, 227, 228, 229, 230, 231, 233, 234, 235, 236, 237, 238, 239, 240, 241, 242, 243, 244	21	Capacitor, .001 mf 500 VW tubular feed thru
17.1106	CH201	1	Chassis
17.1109	CH202	1	Shield, perforated
17.1112	CH203	1	Cover, shield, perforated
23.1362	CH204	1	Cover, bottom assembly
23.1382	CH205	1	Board, meter resistor assembly
23.900-11	D201	1	Gear assembly, final tank
104-250-52	D202	1	Coupling, flexible
23.1499	D203	1	Knob
23.1494	D204	1	Knob
116-223-11	D205, 206	2	Knob
23.1462-1	D207	1	Knob
23.1458	D208	1	Dial Pointer, tank
13.262-3	D209	1	Sleeve coupling
22.1547	D210	1	Push button plug
23.1292-3	E201, 202	2	Suppressor assembly and tube cap
23.1299	E203	1	Suppressor, grid
23.1084	E204, 205	2	Suppressor, screen
16.1449	E206	1	Strap, blocking capacitor
10.19-1	E207	1	Insulator, 1" cone
23.1370	H201	1	Cable, harness
31.344-1	HW	2	Roll pin
22.746	J201	1	Connector, coaxial
23.1426	J202	1	Connector assembly, 11 pin male
23.1427	J203	1	Connector assembly, octal male
105-952	J204	1	Connector, nylon male, red
22.951	L201, 202, 203	3	Choke, 2.5 mh RF
23.1085-4	L204	1	Choke, RF plate
23.1377	L205	1	Inductor, 10 meter final tank
229-204-2	L206	1	Inductor, rotary
102-752-4	L207	1	Choke, RF
16.1181-3	L208, 209, 210, 214	4	Choke, RF
22.1644-29	L211, 212, 213	3	Choke, 3.3 mh RF
22.1688	M202	1	Meter, plate current

VIKING INVADER 2000 HIGH POWER AMPLIFIER

Parts List

Part No. or Drawing No.	Item No.	Qty.	Description
22.1591	R200, 201, 202, 203, 204	5	Resistor, 1000 ohm 10 watt, non-inductive
22.1604	R205, 206	2	Resistor, 3M ohm + 1% 1 watt
22.5067-10	R207	1	Resistor, 5600 ohm + 10% 1/2 watt
22.5083-10	R208, 209	2	Resistor, 27K ohm + 10% 1/2 watt
22.1685	SW201	1	Switch, DPST A.C.
22.1608	SW202	1	Switch, 2 pole 3 position
23.1403	SW203	1	Switch, loading 5 position
22.1600	T201	1	Transformer, filament
22.740-5	TS201	1	Terminal strip, 5 point
22.740-7	TS202, 203	2	Terminal strip, 7 point
22.740-4	TS204	1	Terminal strip, 4 point
22.1751	V201, 202	2	TUBE, PL175A
22.1609	V203	1	TUBE, OC2
122-275	XV201, 202	2	Socket, 5 prong jumbo
22.975	XV203	1	Socket, 7 pin
133-278-8	XS203	1	Shield, tube
16.282-4	XB203	1	Shield, socket base

VIKING INVADER 2000 POWER SUPPLY

Parts List

Part No. or Drawing No.	Item No.	Qty.	Description
16.1447-1	BKT301	1	Bracket, Hi V shorting switch
16.82-29	BKT302	2	Bracket, Hi V shorting switch
16.1447-2	BKT303	2	Bracket, bleeder resistor support
22.1592	C301 thru 308	8	80 mfd, 450 WVDC capacitor
17.1114	CH301	1	Chassis
23.1368	CH302	1	Cover, top
17.1116	CH303	1	Plate, bottom
13.760-2	D301	1	Coupling, rigid metal
16.895-2	D302	1	Spring, Hi V shorting switch
14.568-2	D303	1	Shaft, aluminum, Hi V shorting switch
18.751-4	D304	1	Shaft, phenolic, Hi V shorting switch
16.51-5	E301	2	Connector, plate 866A
10.156-1	E302	4	Insulator, ceramic post 3/8" dia. x 1/2"
10.19-1	E303	6	Insulator, ceramic cone, 1"
10.19-5	E304	4	Insulator, ceramic cone, 5/8"
22.1397-10	F301, 302	2	Fuse, 10 amp. Buss MDL-10
22.1535	F303	1	Fuse, .15 amp., Buss MDL-.15
22.729-2	FH301, 302, 303	3	Post, fuse extractor
23.1371	H301	1	Harness
22.1429-1	J301	1	Connector, 10 amps 3 wire male recessed
22.1087	J302	1	Socket, 2 contact, A.C., female
22.849-2	J303	1	Socket, octal
105-602-3	J304	1	Jack, red, nylon tip
22.1677-2	J305	1	Socket 11 contact
22.1265	L301	1	Choke, Hi V filter, swinging 4-10 hy.
22.1642	L302	1	Choke, Lo V filter, 5 hy.

VIKING INVADER 2000 POWER SUPPLY

Parts List

<u>Part No. or Drawing No.</u>	<u>Item No.</u>	<u>Qty.</u>	<u>Description</u>
22.1430	P301	1	Plug, 3 contact, AC female
22.7099-10	R301 thru 306	6	Resistor, 2 watt carbon, 120K
22.1602	R307, 308	2	Resistor, 50K ohms 225 W
22.1234	R313	1	Resistor, 250 ohm 10 W
22.1031	R309	1	Resistor, 1.5K ohms 25 W
22.1666	R310	1	Resistor, 3.5K ohms 50 W
22.7097-10	R311, 312	2	Resistor, 100K ohms, 2 watt
22.1059	RY301	1	Relay, DPST, 115 VAC
22.1466-2	T301	1	Transformer, Hi V plate
22.1601	T302	1	Transformer, filament
22.1643	T303	1	Transformer, Lo V, power
22.789-5	TS301	1	Terminal strip, 5 terminal, barrier
22.790-5	TS302	1	Marker strip, 5 numeral
22.837	TS303	1	Terminal strip, 2 terminal
22.740-2	TS304	1	Terminal strip, 2 terminal
22.740-3	TS305	1	Terminal strip, 3 terminal
22.212	V301, 302	2	Tube, electron, 866A
22.1104	V303	1	Tube, electron, 5U4GB
23.1373	W301	1	Control cable
122-224-1	XV301, 302	2	Socket, 4 pin ceramic
22.849-2	XV303	1	Socket, octal

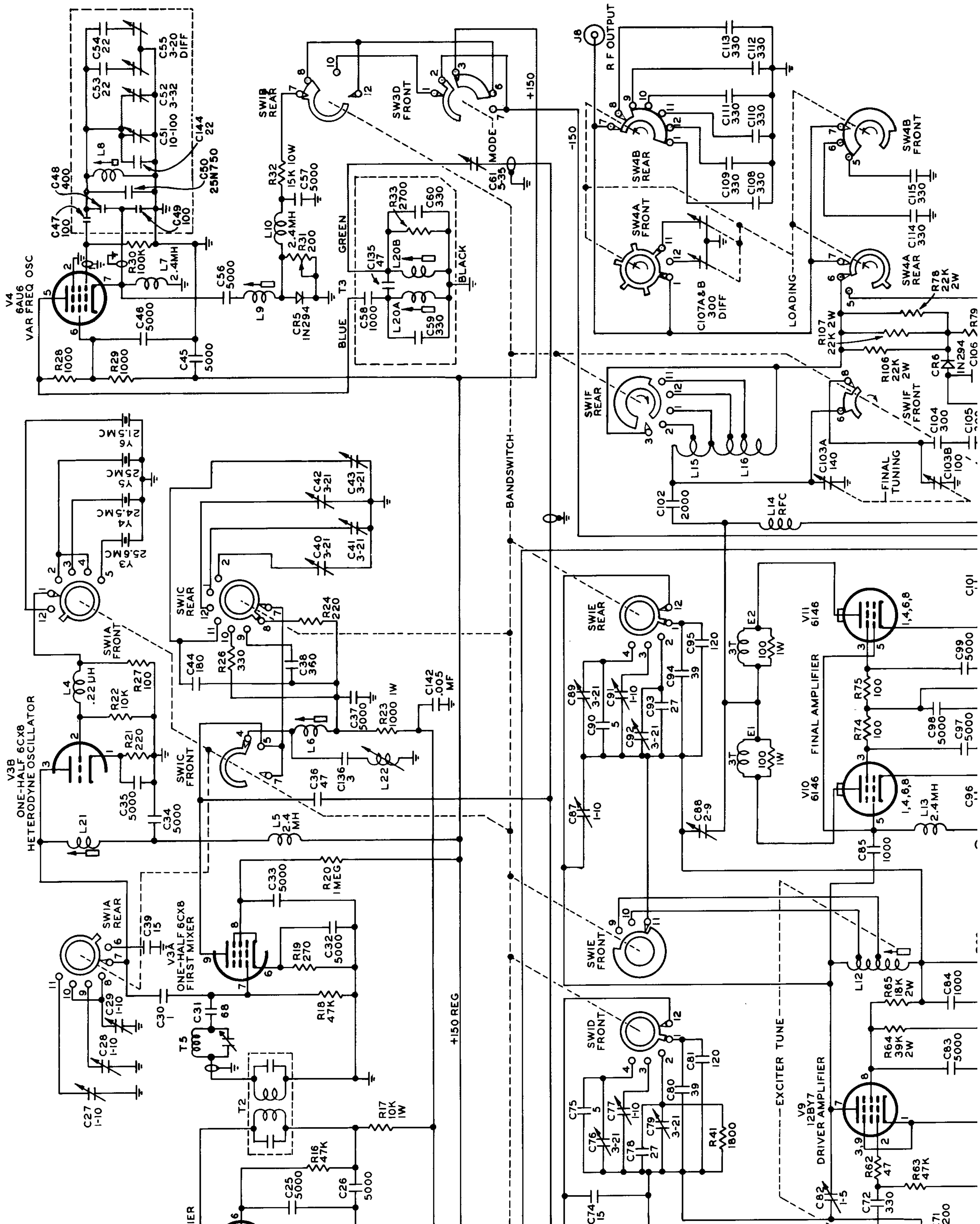

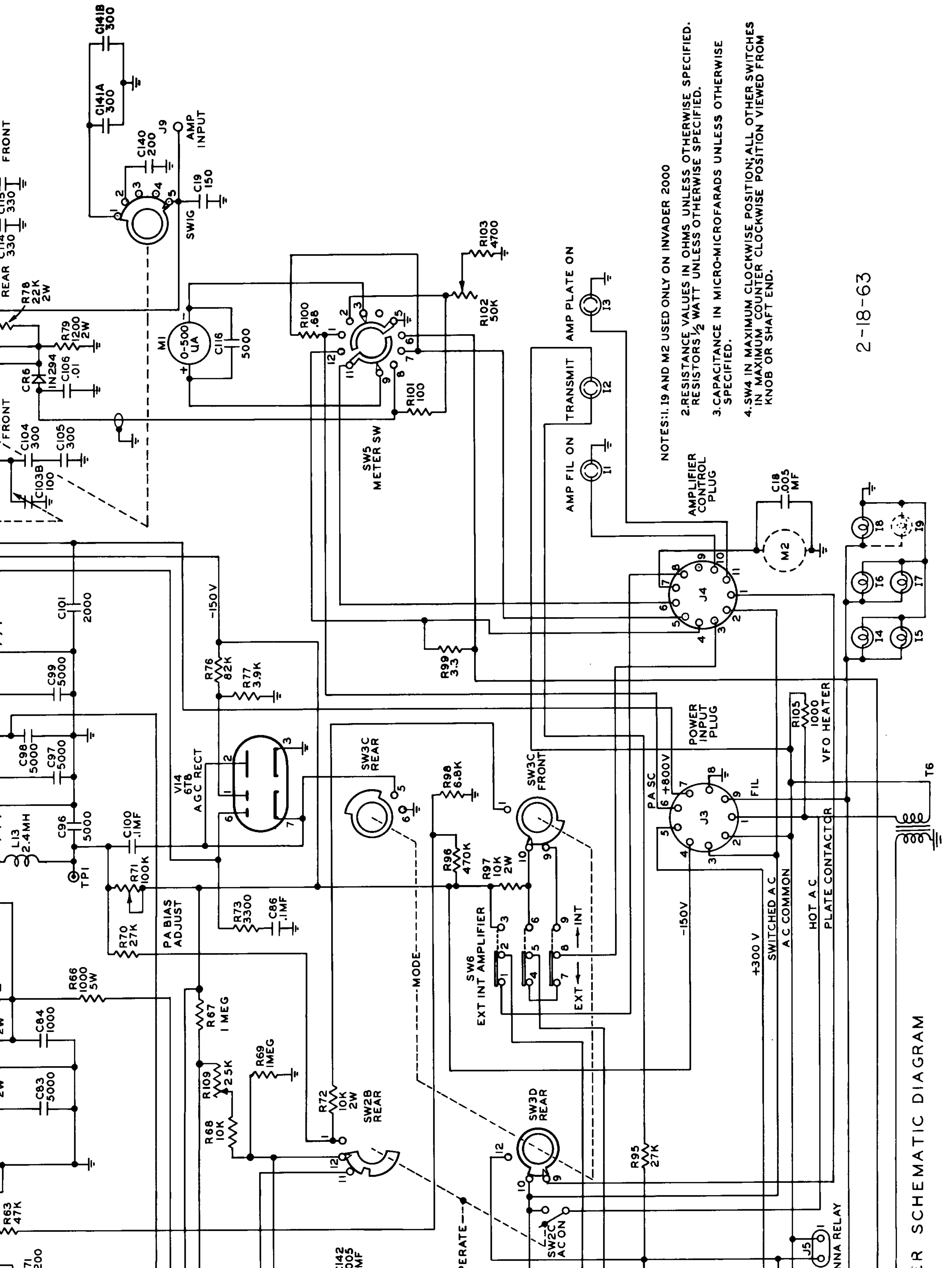

NOTES: 1. R19 AND M2 USED ONLY ON INVADER 2000

2. RESISTANCE VALUES IN OHMS UNLESS OTHERWISE SPECIFIED. RESISTORS 1/2 WATT UNLESS OTHERWISE SPECIFIED.

3. CAPACITANCE IN MICRO-MICROFARADS UNLESS OTHERWISE SPECIFIED.

4. SW4 IN MAXIMUM CLOCKWISE POSITION; ALL OTHER SWITCHES IN MAXIMUM COUNTER CLOCKWISE POSITION VIEWED FROM KNOB OR SHAFT END.

2-18-63

WIRE SCHEMATIC DIAGRAM

