

GENERAL

The KW "VICEROY" SSB Transmitter is designed to be operated with an external Power Supply. The KW Power Supply standard model is for Mains supply voltage 200-250 V. A.C. 45 - 65 cycles. Connection to the Transmitter is by means of a 12 way Cable Connector. When it is intended to use a 'home-built' Power Unit the power requirements must be closely met. It is important that the H.T. supplies and 60 - 80 V. negative voltage supply be well regulated and have a low source impedance.

The Transmitter must be situated with due consideration for ventilation. Nothing must impede the flow of air from under the cabinet, through the Transmitter and out through the top gauge. There should be at least 3 inches clearance behind the Transmitter.

The ideal layout for the equipment is to have the Transmitter on the left of the Power Supply and the Control Box placed in between them. It is quite satisfactory to have the Power Supply under the bench but the controls should be easily accessible.

The 12 way connector at the rear of the Transmitter is provided for external connections to the Transmitter (except Power and Microphone). These connections are indicated in fig. 1. and are primarily intended for use with the KW "VICEROY" Control Unit.

The Transmitter may be operated on SSB with 'Voice Control' without the Control Unit but if an Aerial c/o Relay is employed, provision must be made for holding the relay on 'transmit' while tuning the P.A. Pins 4 & 5 must be linked. If an Aerial c/o Relay with an A.C. coil (6 v.) is used, power for the coil may be taken from the Transmitter heater line, otherwise an appropriate supply must be provided. It is recommended that an Aerial c/o relay be used which 'grounds' the 'receive' contact when on transmit.

Care must be taken in tuning the Transmitter. The tuning of the 'Mixer Input' is quite critical and to facilitate this an indicated scale is provided. It is very important that the P.A. be resonated on the low voltage H.T. position (KW Power Switch at 250 V.) otherwise damage to the P.A. valves may result.

An antenna switch with a low S.W.R. should always be used with this Transmitter.

The V.F.O. has temperature compensation and the Transmitter heaters should be switched on at least ten minutes before operating.

PLEASE READ CAREFULLY THE INSTRUCTIONS GIVEN IN THIS LEAFLET BEFORE SWITCHING ON.

The KW "VICEROY" SSB Transmitter
Installation, Tuning And Operating Instructions

The initial setting up of the KW "Viceroy" should be carried out as follows.

INSTALLATION

Power Supply

1. Adjust the Mains voltage selector panels at the rear of the Power Supply Unit to the correct Mains voltage. Connect the Transmitter to Power Supply by means of ten way connector. The 10 pin sockets are centrally located at the rear of the Transmitter and Power Supply respectively.
2. Check that the Mains switch is 'off' and 'P.A. ANODE H.T' switch is at '0 V.'
3. The P.A. bias voltage control at the rear of the chassis is set up at the Works and will require only slight adjustment (see para.15).

Transmitter

1. Make the appropriate connections from the Control Box to the terminal block on the Transmitter with colour code as indicated in fig. 1(b). Plug a crystal microphone into the socket at the rear of the Transmitter (bottom right-hand co-ax socket - looking at rear). Connect a suitable 52 or 75 ohm Dummy Load into the P.A. output socket (located at rear of P.A. screening box - it will be necessary to remove Cabinet back plate).
2. Turn waveband switch and P.A. switch to band of operation and V.F.O. to required frequency. Set "Mixer input" control to appropriate frequency. Also set "Mixer" and "Driver Anode" control with white spot in same approximate position as "Mixer input".
3. Set "Balance" control to mid-position.
" "Carrier Insertion" control fully anti-clockwise.
" "Audio Gain Control" fully anti-clockwise.
" "Net Control" fully anti-clockwise.
" "Anti-Trip" Control fully anti-clockwise.
4. Turn the Meter Switch to "Grid" current position.
5. Switch on mains switch at Power Supply and allow heaters a few minutes for warming up.
6. Set function switch on Control Box to "Tune".
7. Turn "Carrier Insertion" control clockwise to almost maximum and a reading should be obtained in the meter. (This indication will depend upon the setting of the "Carrier Insertion" control).
8. Having obtained a reading of grid current on the meter, carefully adjust "mixer input", "mixer" and "Driver Anode" for maximum reading. Should the meter

8. go hard over, turn "Carrier Injection" control (contd) anti-clockwise to obtain convenient reading and re-trim "mixer input" "mixer" and "Driver Anode" for maximum reading.

This reading is the P.A. grid current and serves only as a tuning indication, which will vary from band to band. (In operation, the P.A. is only occasionally driven into grid current - Meter indicates 1 m/a full scale deflection).

9. Turn the H.T. switch on the Power Supply Unit to 250 V. This applies H.T. to the Anodes of the P.A. for Tuning only. (H.T. is permanently on the crystal filter exciter and driver stages).
10. Turn the meter switch to P.A. anode current (0 - 300 m/a).
11. Turn the aerial loading control "Output Coupling" fully clockwise and bring "P.A. tune" control to resonance (minimum reading). The correct resonant point should coincide approximately with the following knob positions,
10 metres - 10-11 o'clock; 15 metres 10-11 o'clock;
20 metres 11-12 o'clock; 40 metres 12-1 o'clock;
80 metres (3.5 - 3.7 mc/s) outer 80 position on P.A. coil 1-3 o'clock, (3.7 - 4.0 mc/s) inner 80 position 12-3 o'clock. Should resonance occur at any other position, e.g. on 20 metres with "P.A. Tune" to 9-10, re-check driver stages and make sure that "mixer tune" knob is turned to correct frequency on small dial.
12. The above conditions fulfilled, high voltage may now be applied to the P.A. Turn control on Power Supply Unit to 750 V.
13. Adjust "Output Coupling", in anti-clockwise direction, in small steps while maintaining P.A. resonance with the "P.A. Tune" Control until a current of 200 m/a is obtained.
This is the fully loaded condition of the P.A. stage and it must be emphasised that at no time should the P.A. be operated off resonance.
14. Turn "Carrier Insertion" control fully anticlockwise (carrier off).
15. Adjust potentiometer at rear of Power Supply Unit for a standing P.A. current of 40 m/a.
16. Advance "Audio Gain" to approximately $\frac{3}{4}$ maximum. The Transmitter is now ready for the "Balance Control" to be adjusted.

Balance Control

This control is provided to enable the already very low level of carrier to be removed by the operator and to compensate for any ageing of valves and components that may occur.

It is best adjusted with the Transmitter on 28 mc/s band in the condition described in para's 12, 13, 14 and 15. Turn the meter switch to 'R.f.' position and the "Balance" control fully clockwise. It is also useful to listen for the carrier on the station receiver, with the B.F.O. switched on. (The Balance can be adjusted, with the Transmitter on any band but it will usually be found that 28 mc/s. output gives best indication on the R.f. meter).

Adjust "Balance" control for minimum reading on meter or minimum signal in the Receiver. Once the "Balance" has been set up, there is no reason for further adjustment of this control - only an occasional check every week or so.

OPERATION

The above details having been carried out, the Transmitter is now ready for operation. Replace the dummy load with the antenna feeder.

Function Switch Positions

SSB VOX. The KW "Viceroy" has been designed as a voice operated Transmitter, being only necessary to speak into the microphone in order to switch on the Transmitter and to mute the Receiver. It is suggested that the Transmitter be used on SSB VOX in the following manner but first a suitable method must be found for muting the station receiver, either by a negative voltage being applied to the AVC line or by removing the H.T. to one or more stages. Relay contacts are provided in the Transmitter for this purpose (see fig.1.). It may also be advisable to open-circuit the loudspeaker circuit when on transmit. It is easy to arrange this in conjunction with the leads which are connected from the loudspeaker to the transmitter terminal block at 9 & 10 for completion of the anti-trip circuit. (see Setting up VOX).

Setting up VOX. Operate the Transmitter into a dummy or aerial load as described, with Function Switch to SSB VOX. Adjust R28 on rear of Transmitter chassis (left-hand control looking at rear) until relay in Transmitter just closes, then back off slightly, until, with R21 on P.A. chassis (right-hand control looking at rear) approximately $\frac{3}{4}$ fully clockwise, the relay closes and opens cleanly on speaking into the microphone.

Connect the low impedance output of Receiver to Transmitter and tune-in a station at normal listening volume on the Receiver loudspeaker. It will be found that noise from the Receiver triggers the relay, unless the "Anti-trip" control is correctly adjusted. This must be done in conjunction with R21 and adjustments on these two controls must be made to achieve satisfactory operation, i.e. noise from the Loudspeaker does not operate the relay. Only speech input into the microphone should operate the relay thereby switching on the Transmitter and muting the Receiver.

Tune. In this position the Transmitter is switched on and the aerial relay closed. This enables the Transmitter to be tuned when some carrier is inserted.

C.W. This position closes the aerial relay contacts and with some carrier inserted enables the Transmitter to be keyed. The Transmit/Receive Switch is used. 'Audio gain' control should be turned fully anti-clockwise.

SSB MOX. This position is for SSB transmission without 'voice-control' the Transmit/Receive switch being used.

Netting

Netting on SSB VOX and SSB MOX is achieved by turning the 'Net' control fully clockwise and beating with the received signal. In most installations it will be necessary to insert some carrier by means of the 'Carrier Insertion' control in order to obtain sufficient signal from the Transmitter. When netting on CW the 'Net' control is adjusted with the Transmit/Receive switch in the 'Transm.

more than one response be heard

Carrier In
r injectio

Automatic Linearity Control A.L.C.

When the A.L.C. Unit is incorporated in the KW "Viceroy" it is mounted on the outside rear of the P.A. screening box. This device limits P.A. grid current to a level determined by a potentiometer R 81 mounted on the A.L.C. Unit, thus enabling more average grid drive without resulting in overdriving the P.A.

The A.L.C. may be made inoperative by turning the potentiometer R 81 fully anti-clockwise. In operation with or without A.L.C. the P.A. grid current should only "kick-up" slightly on speech peaks and the 'Audio Gain' control should be adjusted to meet this condition.

The optimum adjustment can only be found by observing the Transmitter output on an oscilloscope, this being done at the Works before despatch.

R.F. Output Indication.

This is provided by rectifying a very small part of the voltage appearing at the output of the P.A. Pi filter. The R.f. output indication is available by turning the meter switch to 'R.f. Output'. If the co-axial feeder is correctly matched to the antenna it may be assumed that an increased reading on the meter coincides with an increased power into the feeder. With

R.F. Output Indication (contd.)

With a high S.W.R. or a load higher in impedance than 50 - 80 ohms the reading may be slightly misleading and in this case it is advisable to use an S.W.R. indicator in the feeder. The R.F. indication may vary from band to band and in general a higher indication will be available on the higher frequency bands.

Re-tuning

It is most important when changing bands or for a large change in frequency the P.A. 'Grid Current' must be monitored and 'P.A. Anode H.T.' switch at the Power Supply turned to 'O.V.' Put the function switch in the 'TUNE' position. Insert some carrier and re-tune 'Mixer Input', 'Mixer Anode' and 'Driver' controls.

Two Tone Test Conditions (A.L.C. off)

With optimum settings of audio gain and carrier insertion, P.A. Anode current on resonance (maximum is 150 m/a). P.A. current offresonance 190 m/a.

Whistle peaks 200 m/a - No grid current indicated. THE P.A. ANODE CURRENT MUST NEVER EXCEED 200 M/A UNDER ANY CIRCUMSTANCES.

A.M. Operation

The Transmitter can be operated in a form of low efficiency amplitude modulation by inserting some carrier and slightly unbalancing the balanced modulator. It is advisable to monitor the transmission on the station Receiver with R.f. gain turned well back while adjustments are being made. Turn the KW Power Supply switch to 250 V. The 'Carrier Insertion', 'Balanced Modulator' and 'Audio Gain' controls should be adjusted until clear speech is heard in the Receiver. The KW Control Unit function switch should be turned to 'SSB MOX' and the Send/receive switch on 'send'. Turn the Power Supply switch to 750 V. and quickly re-load P.A. by adjusting 'Output Coupling' and 'P.A. Tune' for a P.A. anode current of not more than 100 m/a on 'Dip' (meter switch to P.A. anode). It is usual for the carrier insertion control to be turned clockwise only a small amount from minimum and the audio gain quarter to half-way up. Note the position of the 'Balanced Modulator' knob before turning, in order that it may easily be re-set for SSB operation without re-checking for maximum carrier rejection.

Removing Chassis

To remove chassis from cabinet, unscrew three fixing bolts under cabinet at rear. Remove six screws from around edge of front panel (middle bottom one has nut behind it) and withdraw by placing fingers behind both sides of front panel.

Note: There may be a change of indicated P.A. grid current when H.T. is applied to P.A. but this is quite normal.

DO NOT TOUCH the potentiometer on top of the crystal filter chassis as this is set up at the Works and should not require further adjustment

ERRATA

Amend Para 6 to:- Set function switch to VOX and
turn "Net" control to Maximum

At end of Para 8 add:- Turn "Net" control fully
anti-clockwise.

Para 9 add:- Put Function switch to "Tune"

Amend Para 15 'Adjust potentiometer for a
standing P.A. current of 40 m/a.

Page 3 Setting up VOX

add:- The amount of delay for relay holding
on transit can be reduced by turning
R28 clockwise from "threshold" adjustment.

Page 5 Removing Chassis

add:- 3 screws must also be removed
from under cabinet at rear.

7 VIOLET 8 YELLOW

Fig.1(a)

Connections to 12 way block at rear of P.A. chassis when used with switching other than the KW Control Unit.

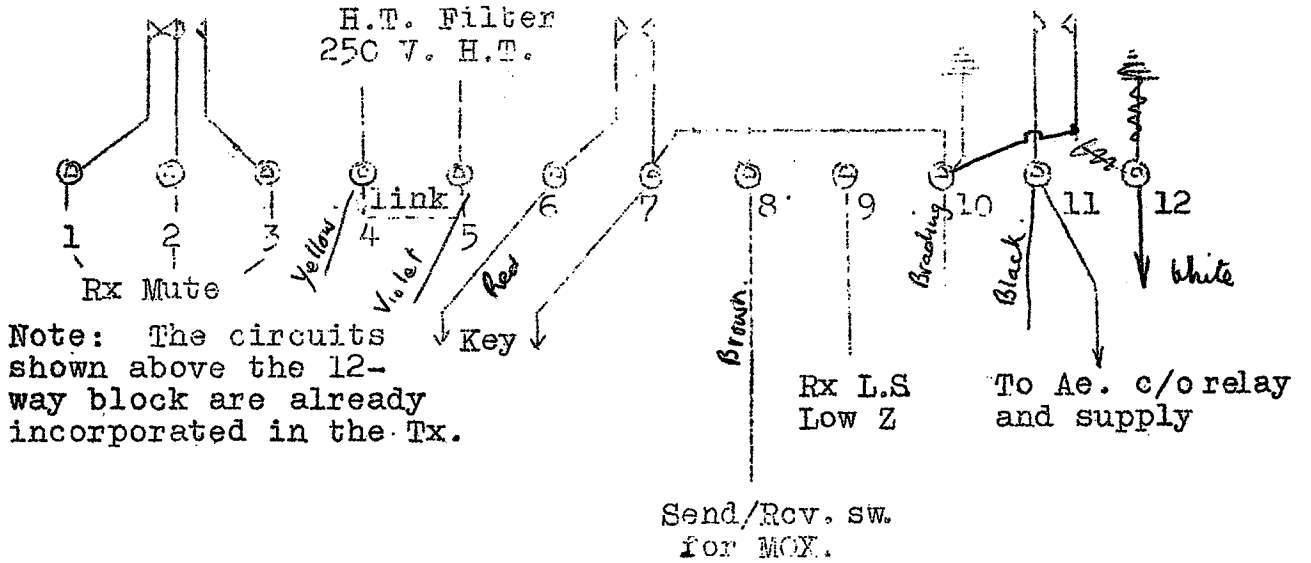

Note: The circuits shown above the 12-way block are already incorporated in the Tx.

Fig.1(b)

Connections to KW Control Unit (in PSU)

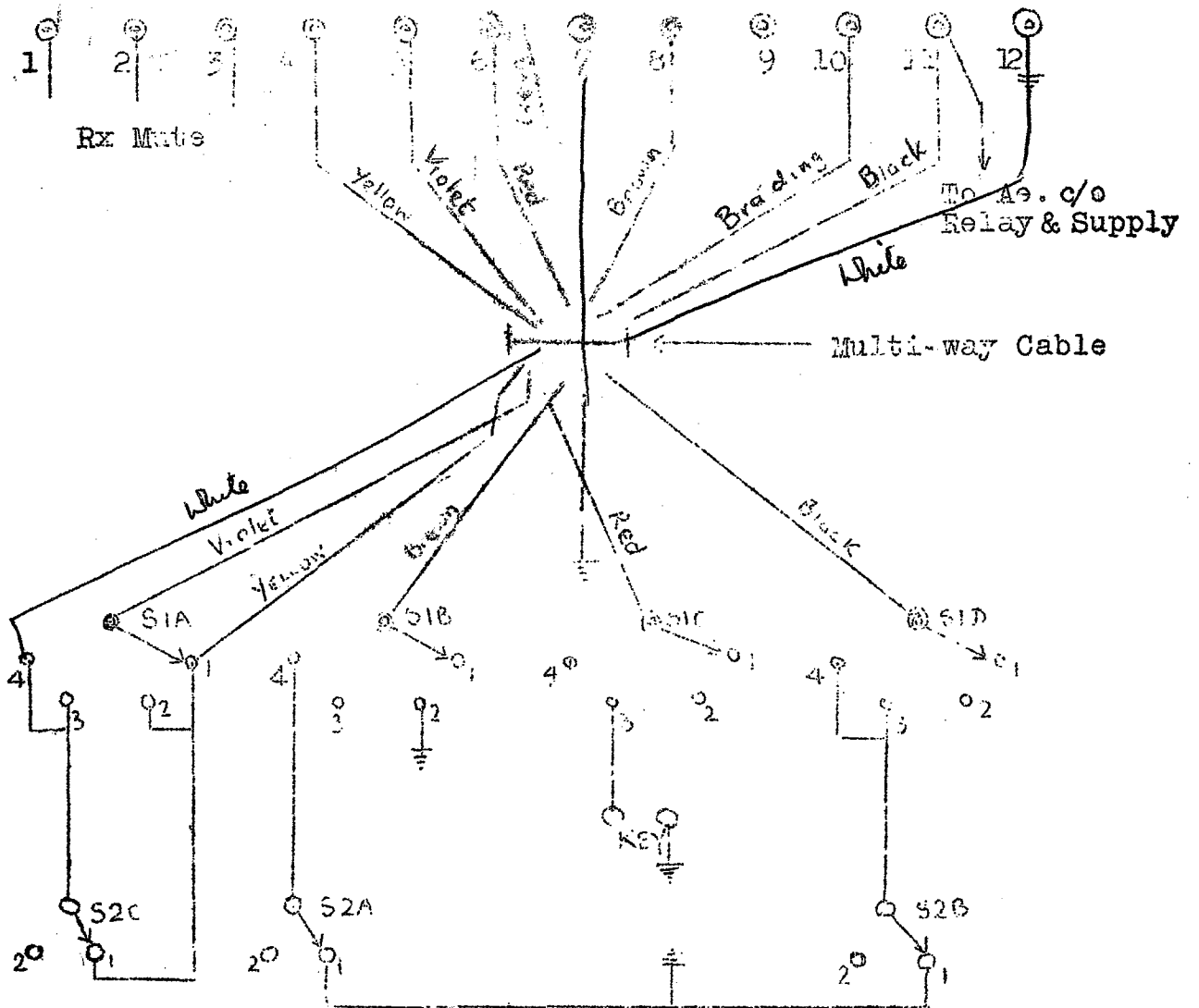

S1 Position 1 SSB VOX
2 TUNE
3 CW
4 SSB MOX

S2 Position 1 XMT
2 RCV

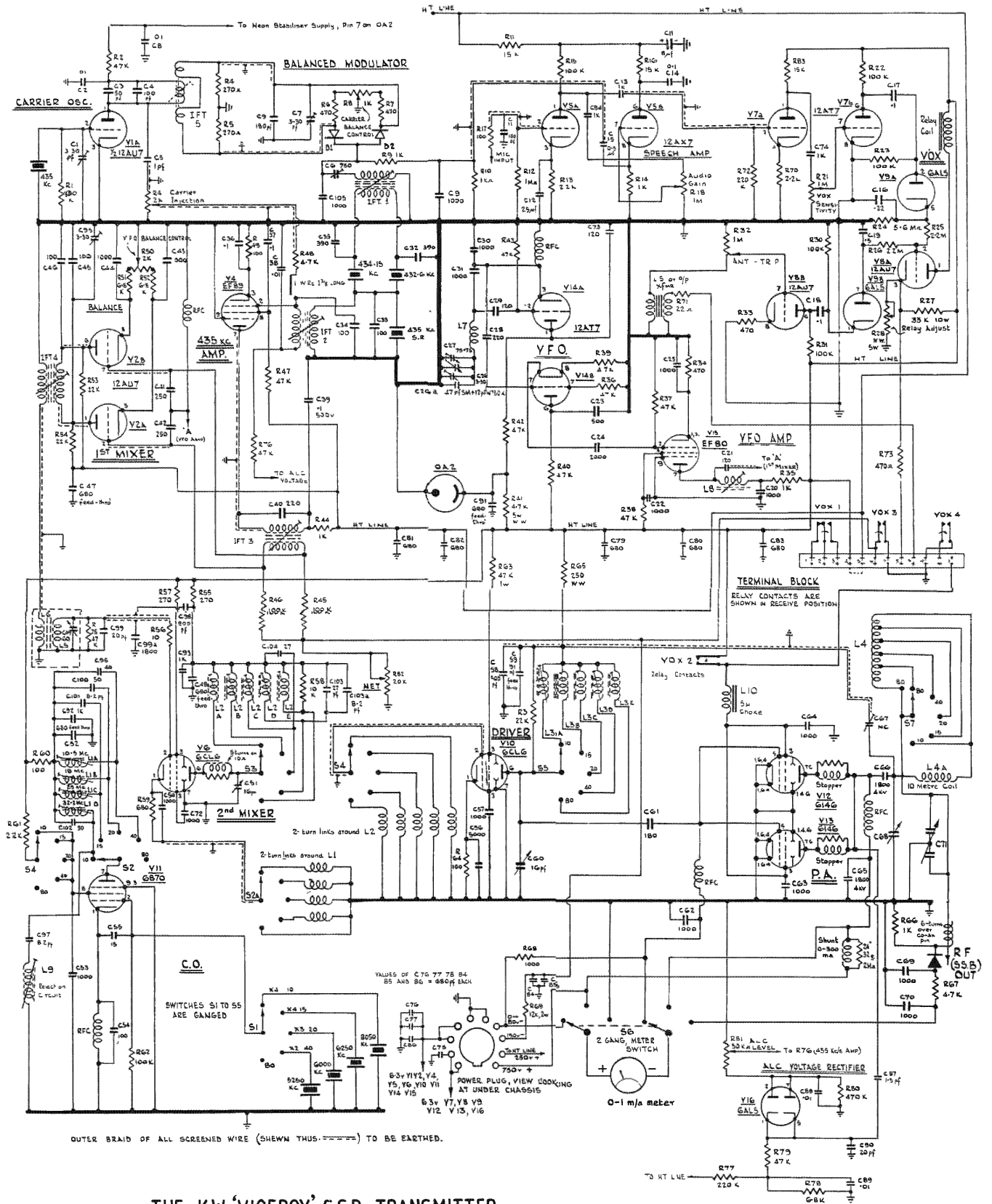

OUTER BRAID OF ALL SCREENED WIRE (SHOWN THUS-----) TO BE EARTHED.

THE K.W. 'VICEROY' S.S.B. TRANSMITTER.

COPYRIGHT OF K.W. ELECTRONICS LTD, VANGUARD WORKS, DARTFORD, ENGLAND.

DRAWING No VIC/1

ISSUE A - 1-2-60