

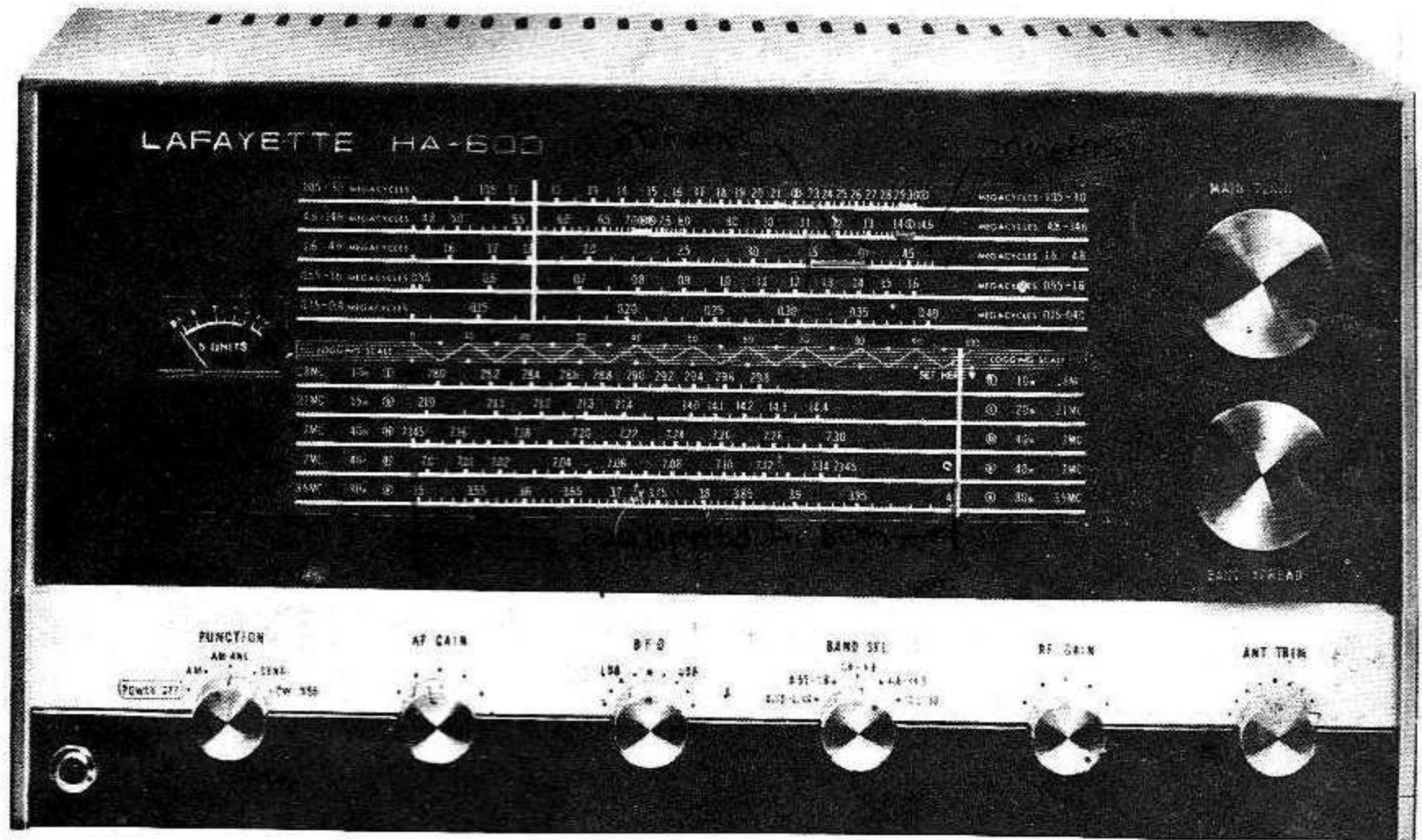

LAFAYETTE

Model HA-600A

(Stock No. 99-25991WX)



SOLID STATE AMATEUR AND SHORTWAVE RECEIVER



INSTALLATION AND OPERATING MANUAL



LAFAYETTE

Model HA-600A

(Stock No. 99-25991WX)

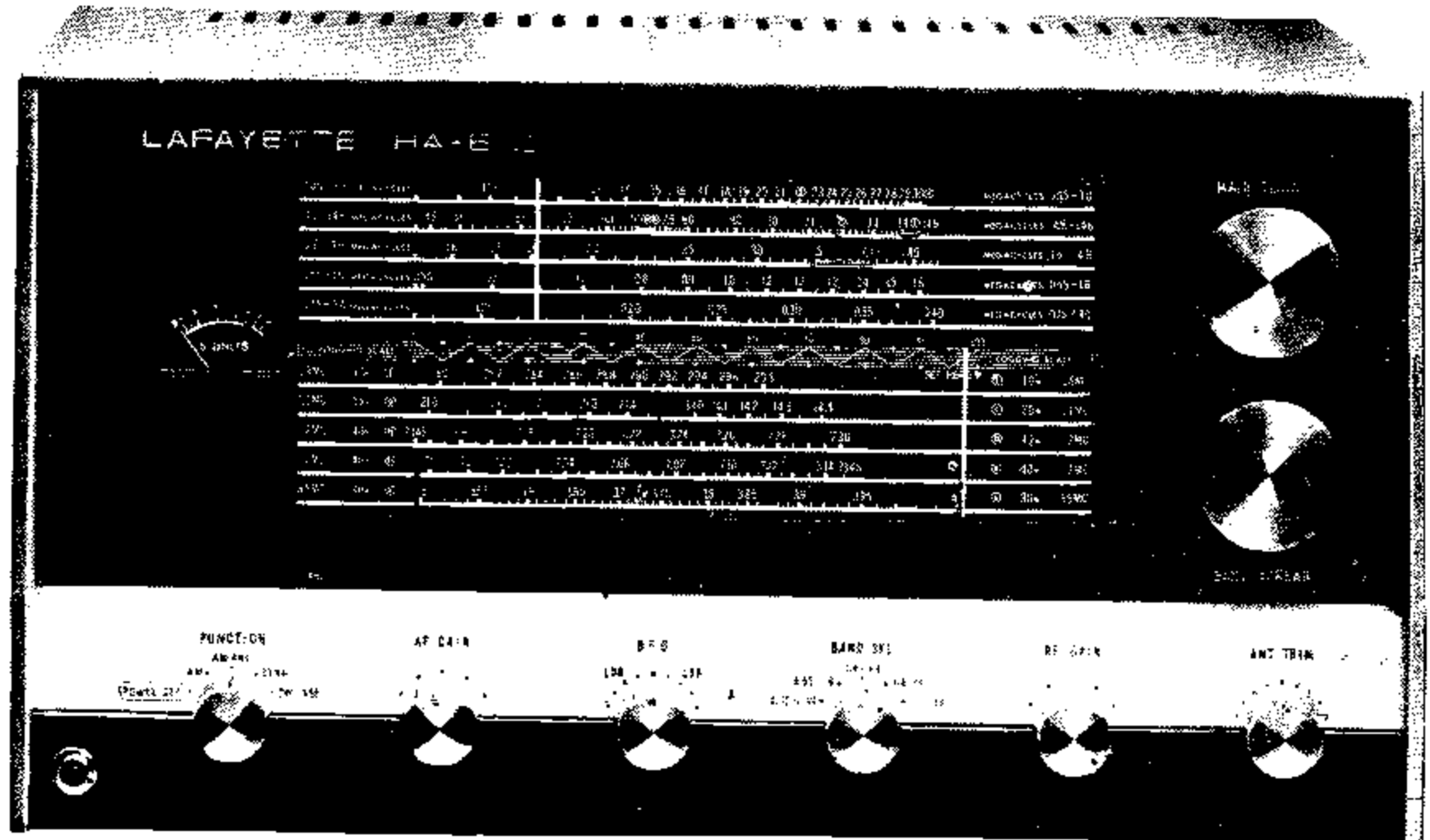

SOLID STATE AMATEUR AND SHORTWAVE RECEIVER



INSTALLATION AND OPERATING MANUAL

HA - 600A

TECHINICAL SPECIFICATIONS

FREQUENCY RANGE	150 KHz to 30 MHz in five bands.		
	0.15 - 0.40 MHz		
	0.55 - 1.6 MHz		
	1.6 - 4.8 MHz		
	4.8 - 14.5 MHz		
	10.5 - 30.0 MHz		
SENSITIVITY	1 μ V at 10 db S/N ratio.		
SELECTIVITY	\pm 6 KHz at 60 db down; \pm 2 KHz at 6 db down.		
INTERMEDIATE FREQUENCY	455 KHz.		
BFO FREQUENCY	455 KHz \pm 2.5 KHz.		
ANTENNA INPUT IMPEDANCE	50 - 400 ohms.		
AUDIO OUTPUT IMPEDANCE	4, 8 and 500 ohms.		
AUDIO POWER OUTPUT	3 watts at 4 ohms.		
TRANSISTOR COMPLEMENT	TR-1	2SC605	RF Amplifier
	FET-1	2SK19[GR]	Mixer
	FET-2	2SK19[GR]	Local Oscillator
	FET-3	2SK19[GR]	RF Amplifier
	TR-2	2SC183[R]	1st IF Amplifier
	TR-3	2SC183[R]	2nd IF Amplifier
	TR-4	2SC710	Beat Frequency Oscillator
	TR-5	2SC710	Product Detector
	TR-6	2SC712	1st Audio
	TR-7	2SC712	Audio Driver
	TR-8,9	2SC1013	Push-Pull Audio Output
	TR-10	2SC712	Voltage Regulator
	TR-11	2SC712	Voltage Regulator
	TR-12	2SC712	AGC Amplifier
DIODES	D-2	1S34	AM Detector
	D-3	1S34	Automatic Noise Limiter
	D-4	1S34	S-Meter Rectifier
	D-5	1S1210	Temperature Compensation
	D-6	1S1210	Temperature Compensation
	D-7	RD-7A	Voltage Regulator
	D-8,9	V06B	Full-Wave Rectifiers
	D-10	RD-7A	Voltage Regulator [Zener]
POWER REQUIREMENTS	105 - 120 volts, 50/60 Hz AC		
DIMENSIONS	15" W. x 9 $\frac{3}{4}$ " D. x 8 $\frac{1}{4}$ " H.		
NET WEIGHT	17 lbs.		

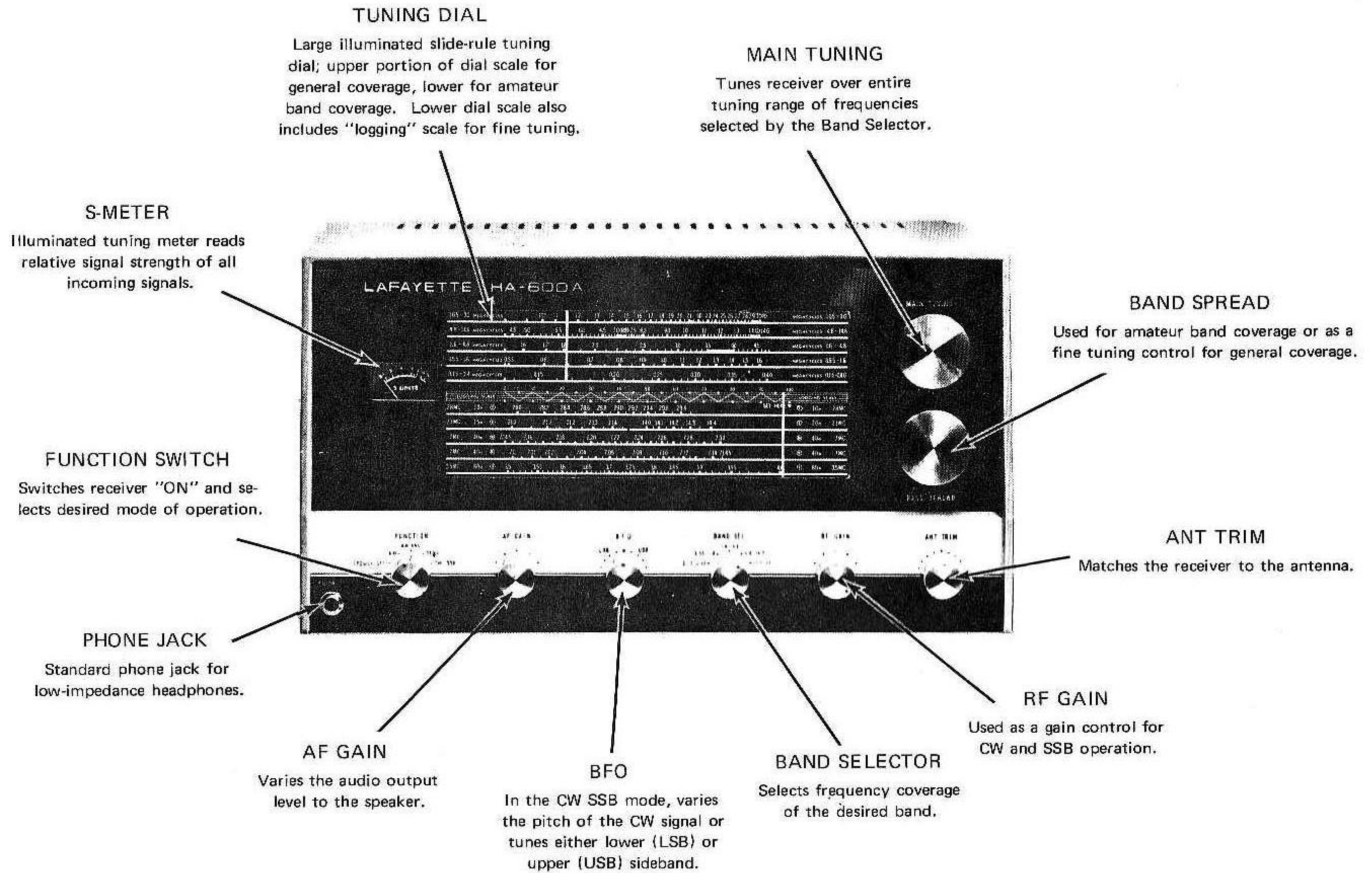

Figure 1. Front View

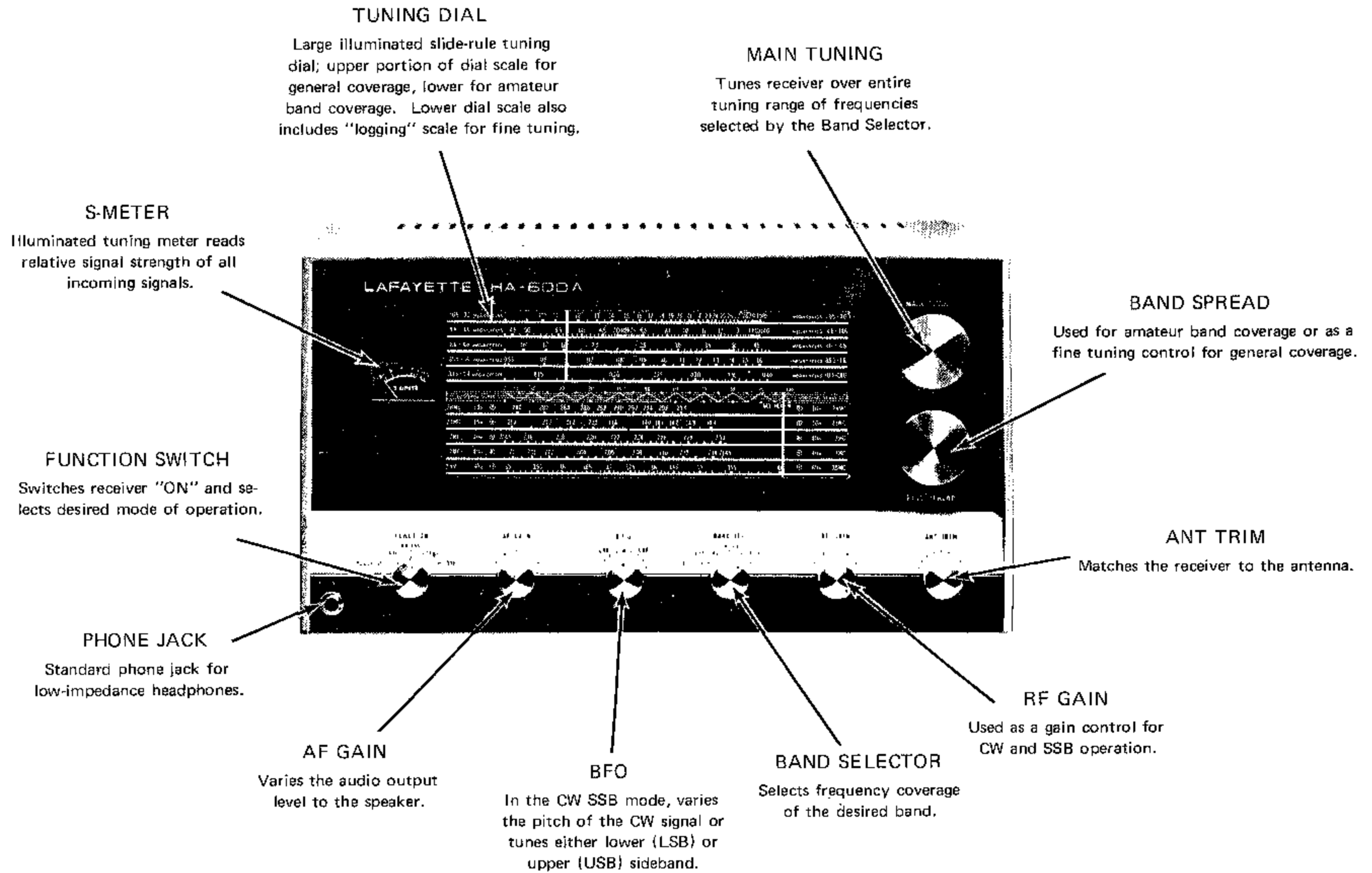

Figure 1. Front View

GENERAL DESCRIPTION

The Lafayette Model HA-600A is a sensitive solid state superheterodyne receiver designed to meet the needs of the Radio Amateur as well as the most demanding short-wave listener. The large illuminated side rule tuning dial clearly and accurately indicates receiver frequencies from 150 KHz to 30 MHz in five bands. For extreme accuracy, a band spread tuning dial is incorporated with direct dial calibrations on the 80, 40, 20, 15 and 10 meter amateur bands. A 0-100 logging scale is also included on the band spread dial to assist in logging other than amateur band frequencies. Through the use of two separate tuning dials, optimum read-out and operation is provided. The HA-600A is designed to receive CW (code), AM (phone) and SSB (single sideband) within the frequencies covered by the receiver. When receiving SSB or CW signals, the variable BFO (beat frequency oscillator) may be used to select the desired sideband or adjust the pitch of the CW signal.

The receiver employs a tuned RF and Mixer stage to give maximum sensitivity and a high signal-to-noise ratio, while two Intermediate Frequency stages and a mechanical filter provide a high degree of selectivity. A product detector operating in conjunction with the BFO is employed for CW and SSB operation, while a separate diode detector is used for AM reception.

The all transistor design of the receiver offers all the advantages expected from solid state circuitry - - instant operation, low current consumption and cool operation. The receiver is designed to operate from 105-120 volts 50/60 Hz AC.

The antenna input is designed for use with unbalanced type lines of 50-400 ohms impedance. An antenna trimmer control provides the required matching of the antenna to the receiver. A tape recorder output as well as audio outputs of 8 or 500 ohm impedance are provided on the rear panel.

The HA-600A receiver will provide reliable short-wave and amateur band reception in its intended application if operated in accordance with this manual. We suggest that you keep the manual close at hand and in a safe place so that you may refer to it whenever necessary.

UNPACKING INSTRUCTIONS

The receiver has been packed with adequate internal carton bracing and cushioning to withstand normal handling in shipment on common carriers. Examine the carton exterior for signs of severe damage (crushing, piercing, etc.). In the event of obvious serious damage, examine the equipment carefully to determine the extent of internal damage, save packing material and make claim against transportation company.

It would be a good idea if the shipping carton and internal packing were saved for a period of time. Many customers have found that saving the carton is a great convenience in the event of moving or prolonged storage. It should also be kept in mind that if it should become necessary to return the receiver for repair under Warranty, it must be returned in the original shipping carton.

INSTALLATION

LOCATION

In general the location of the receiver is not critical; it may be placed in any location that proves convenient to the operating controls. Care should be taken to avoid excessively warm locations such as those near radiators and/or heating vents. An inch or so of clearance between the back of the receiver and the wall should be allowed for proper ventilation.

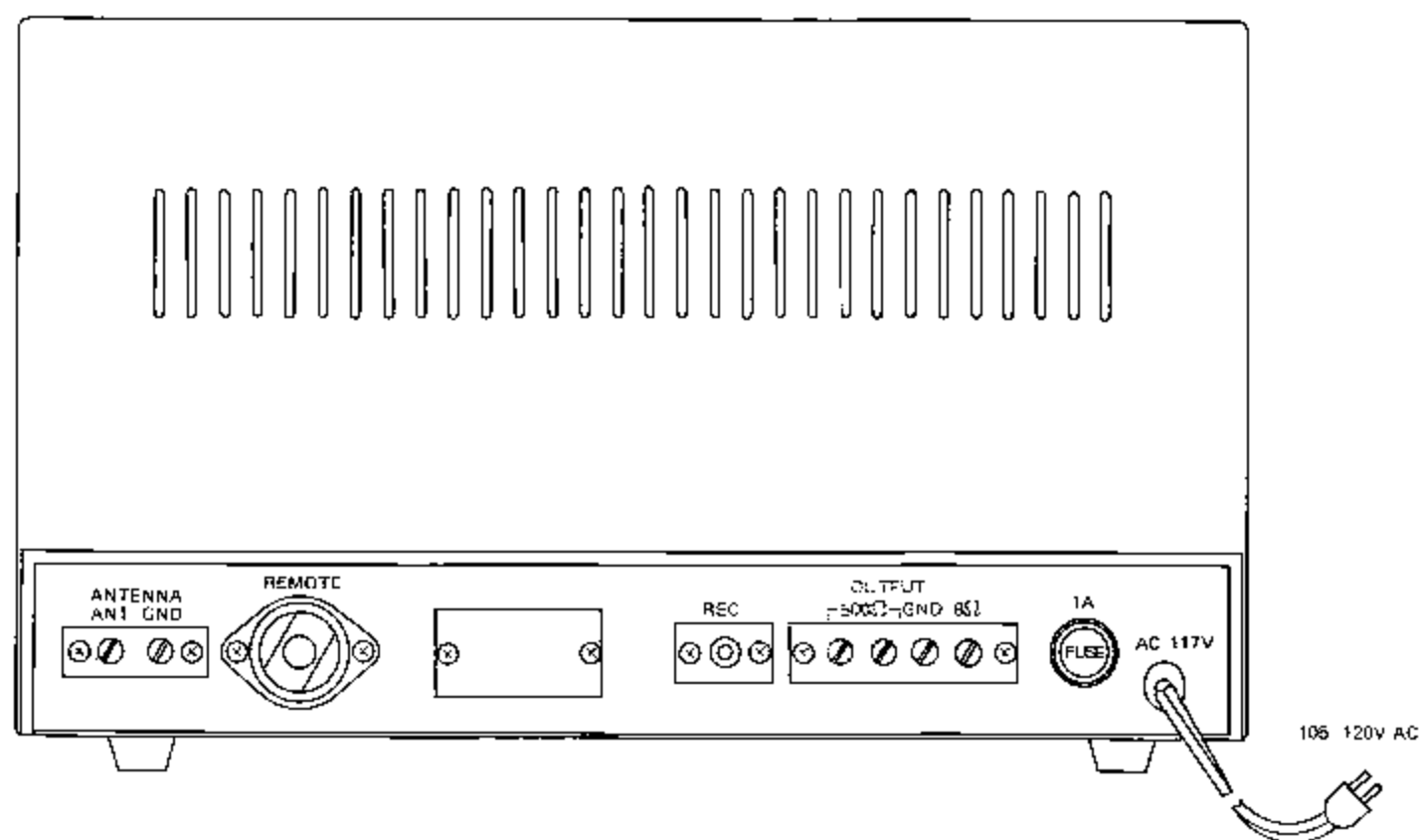

FIGURE 2 - REAR VIEW

ELECTRICAL POWER

The receiver is designed to operate from 105-120 volt 50/60 Hz AC power source. Operating the receiver on any other AC power source will severely damage the unit.

HEADPHONES

The front panel PHONES jack is provided for operation where headphone listening is desired. This jack mates with a standard 2-conductor phone plug available from any local electronics parts store or Lafayette Radio Electronics. For optimum results, the headphones should be of the low-impedance type although impedances up to 2000 ohms will provide satisfactory operation. Insertion of the phone plug into the front panel jack automatically silences the speaker and/or phones connected to the 8 or 500 ohm output terminals.

SPEAKER CONNECTIONS

A 4-screw terminal strip (marked OUTPUT) is provided on the rear of the receiver for connection of speakers on or connection of a 500 ohm line. Any PM (Permanent magnet) speaker with a 4-8 ohm impedance may be used when connected directly across the terminals marked GND and 8Ω. An excellent speaker for this purpose is the Lafayette Model HE-48B speaker (available under Stock No. 40-09056).

If you wish to have speaker and headphone operation simultaneously, phones may be wired directly across the 500Ω output terminals. The headphones connected to these terminals should be of the low impedance type (up to 2000 ohms).

TAPE RECORDER CONNECTION

Provision has been made in the receiver to permit recording of all signals being received. A special output jack on the rear chassis (marked REC) is provided for connection to the Radio/Aux input on a tape recorder. Use a shielded audio cable terminated with an RCA-type phono plug (this plug matches the REC jack on the receiver) to connect the receiver to the tape recorder. The audio output at this jack is present during all modes of receiving.

REMOTE SOCKET/JUMPER PLUG

The REMOTE socket end plug on the back of the HA-600A allows control of the receiver when used in conjunction with a transmitter. Most transmitters contain terminals for receiver switching; if not, an external switching device can be constructed. In the case of remote switching, the FUNCTION switch should be set to the AM, AM/ANL or CW/SSB position depending on the desired mode. For normal operation the jumper plug must always remain inserted in the REMOTE socket. Figure 3A reflects the original Remote Plug wiring. Figure 3B illustrates the manner in which the plug is wired for transmitters containing a pair of relay contacts for receiver control. Removing the original jumper wire at point "X" and connecting a pair of wire leads to the relay, switches the B+ to the receiver. With the contacts closed, voltage will be applied in the usual manner; contacts opened will break the B+ line and put the receiver in a "standby" mode. Figure 3C illustrates the plug wiring when the receiver is used with a transmitter that provides a "muting" voltage. This muting voltage (available on most SSB transmitters) mutes or quiets the receiver during transmissions. If it is desired to only connect a remote 8-ohm speaker to the plug, it may be connected directly across pins 1 and 8 with the original jumper wires connected.

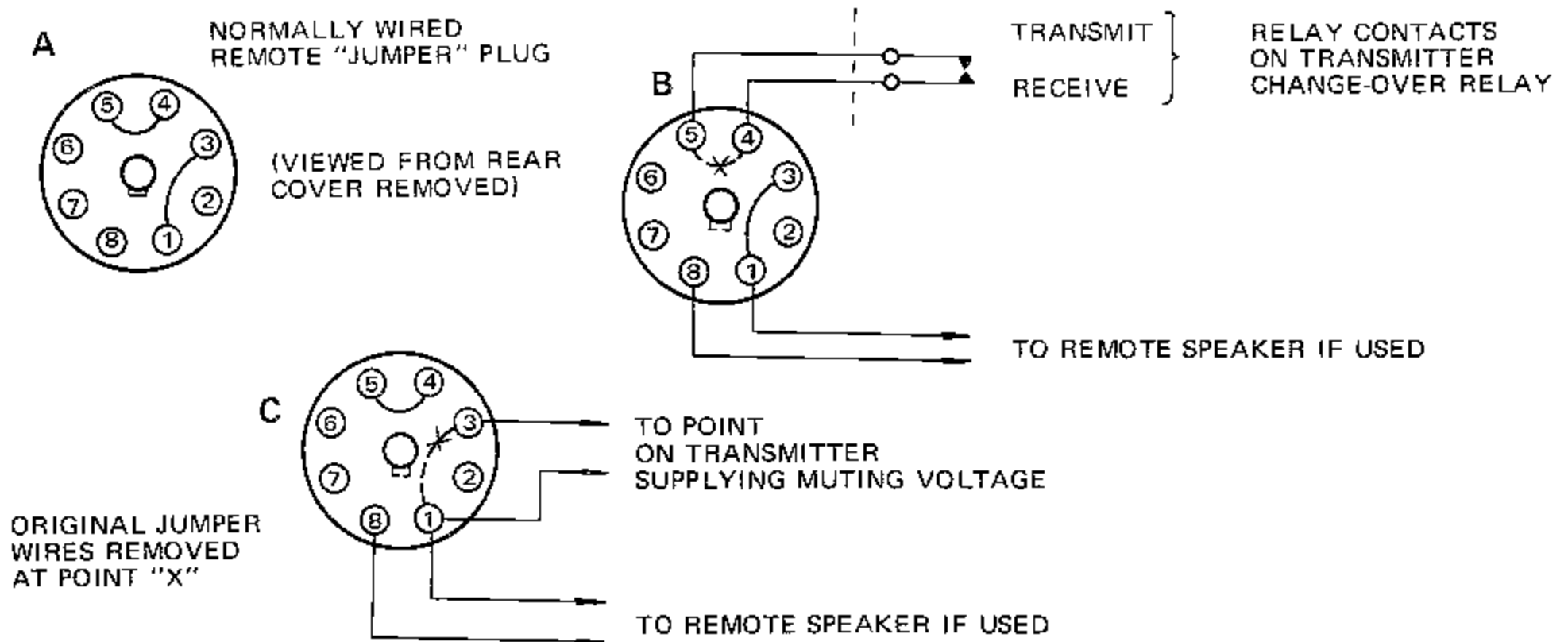

Figure 3. Plug Wiring

FUSE

The fuse socket on the rear chassis contains a 1-ampere (slow-blow) protective fuse. If replacement becomes necessary, replace only with one of the same rating. Unscrew the spring loaded cap (marked FUSE) to remove the fuse.

ANTENNAS

The receiving capabilities of your Lafayette HA-600A receiver will be greatly determined by the efficiency of the antenna system used. Best results will be obtained with any antenna if it is installed as high and in the clear as possible. This will ensure minimum noise pick-up and permit better reception of signals. Due to the complexity of the subject, it is not within the scope of this manual to provide extensive information on antenna systems, although this section does contain some general information that may be of value.

The receiver is designed to operate from a single wire or a balanced type antenna. The front panel antenna trimmer control permits a good match to most antenna systems of 50-400 ohms. The antenna input circuit is of the unbalanced type and is ideally suited for use with a coaxial transmission line.

More elaborate antenna systems than those suggested in this section may be installed to provide better performance. Information on a number of different types can be obtained by referring to the Radio Amateur's Handbook or the ARRL Antenna Book, both published by the American Radio Relay League.

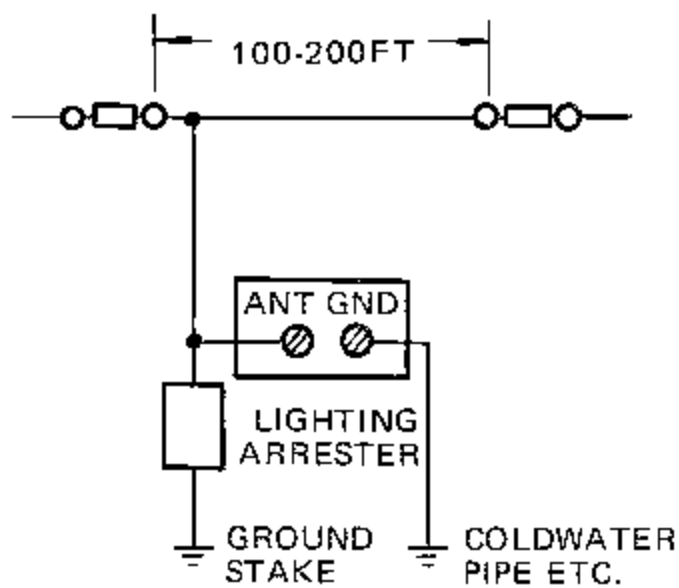

Figure 4. A

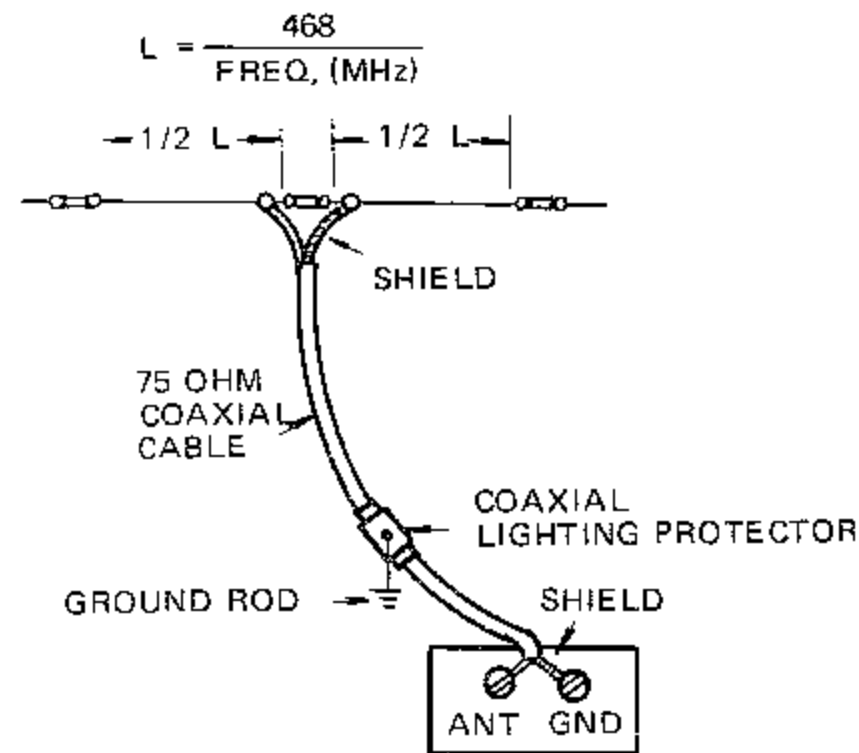

Figure 4. B

SINGLE WIRE ANTENNA

The end fed or single wire antenna will provide satisfactory performance over the entire tuning range. Simply connect the antenna wire to the Antenna "ANT" terminal on the rear apron. For good reception, the antenna wire should be placed as high as possible and 100-200 feet long (See Fig. 4A). Generally, this type antenna provides maximum pick-up at right angles to its entire length. This should be kept in mind when installing the antenna. In some locations, reception may be improved by connecting a ground wire from the Antenna "GND" terminal to a cold water pipe or outside ground rod. For protection against lightning, a lightning arrester should be installed in the antenna system.

DIPOLE ANTENNA

A dipole or doublet antenna will give excellent results, especially on amateur bands. A 75 ohm coaxial cable transmission line should be used to connect the antenna to the receiver as shown in Figure 4B. Since the dipole antenna provides optimum performance only at a given frequency, it should be cut to the length for the most used band of frequencies. The overall length of the dipole antenna may be determined by using the following formula:

$$\frac{468}{\text{Frequency in MHz}} = L \text{ (Length in feet)}$$

For example: If operation is desired on 3.5 MHz (the low end of the 80 meter amateur band), the length of the antenna should be approximately 134 feet as determined by the formula.

$$\frac{468}{3.5 \text{ MHz}} = \text{Approximately 134 feet.}$$

Since the dipole antenna displays directional properties broadside to its length, it should be oriented in such a manner that maximum signal pick-up can be obtained from the desired direction. An antenna height of 30-50 feet is recommended for good reception of weak signals. Close proximity of the antenna (and lead-in) to power lines, telephone lines, trees, other antennas, etc., should be avoided. Also, be sure to include a lightning arrester in the installation.

OPERATION

TUNING

The main and band spread tuning dials are calibrated in megacycles and contain markings throughout the dial to simplify tuning. The major amateur radio bands are contained in the 1.6-4.8, 4.8-14.5 and 10.5-30 MHz scales. The location of each amateur band is indicated by a small circled letter or letter and number that appears near the amateur band frequencies on the main tuning dial. These amateur band markings may be found on, or near 4.0, 7.0, 14, 22 and 30 MHz on the main tuning dial. The BAND SElector must be set to the range or band of frequencies desired.

Bandspreading on the amateur bands is carried out by initially setting the bandspread pointer to 100 on the Logging Scale and the main tuning pointer directly over the circled letter (or letter and number) for the band to be tuned. The tuning range of the calibrated bandspread dial to be used is indicated by the corresponding letter (or letter and number) to the left and right-hand side of the bandspread scale. On the 40 meter amateur band it will be noted that the band is split between two markings (B1 and B2). B1 and B2 together cover the full range of frequencies on the 40 meter band (7.0 to 7.3 MHz) - - B1 from 7.0 to 7.145 MHz, B2 from 7.145 to 7.3 MHz. Thus, if the main tuning pointer is set over B1, the bandspread scale to be used is the one marked B1. In turn, when the BAND SElector is set to the desired band, and the main tuning pointer is set to a letter (or letter and number) marking, the tuning is accomplished solely with the BAND SPREAD control on the appropriate scale.

For tuning other than the amateur radio bands, the HA-600A may also be operated as a general coverage shortwave receiver. On the shortwave bands, radio stations are found transmitting from all over the world. Many of these stations provide English-language broadcasts; however there are also

stations transmitting in different foreign-languages. The frequencies on which most shortwave broadcast stations operate are found in the two upper bands of your receiver. The majority of shortwave broadcast stations operate within certain internationally assigned groups of frequencies or "bands".

For your convenience, a list of the shortwave bands which offer best reception has been provided. Shortwave reception varies with the time of day, season of the year and weather conditions. As a general rule, however, the frequencies on which best reception is obtained become lower as the day progresses. Thus, you will generally find that the 11, 13, 16 and 19 meter bands are best during the day, and the 25, 31, 41, 49 and 60 meter bands best toward the evening and night.

Table 1. Shortwave Bands

SHORTWAVE BROADCAST BAND*	FREQUENCY (MHz)
60 meter band	4.80 to 5.00
49 meter band	5.90 to 6.40
41 meter band	7.10 to 7.40
31 meter band	9.20 to 9.70
25 meter band	11.60 to 12.00
19 meter band	15.10 to 15.45
16 meter band	17.70 to 17.90
13 meter band	21.45 to 21.75
11 meter band	25.40 to 26.10

* These are separate and distinct from the Amateur Shortwave bands which operate over different groups of frequencies.

When tuning shortwave stations, the BAND SElector should be set to the desired band, the bandspread pointer should initially be set to 100 on the Logging Scale and the main tuning pointer to the high end of the shortwave frequency to be tuned. The BAND SPREAD control may then be used to tune over the band. Moving the bandspread pointer towards "0" on the Logging Scale subtracts from the frequency indicated on the main tuning scale. Logging of shortwave stations is possible by noting the readings on both the Main Tuning and Logging Scales.

If additional information is required, many publications are available on the subject of listening and locating various shortwave broadcast stations. One such publication is "Better Shortwave Reception" (available from Lafayette Radio Electronics under Stock No. 10-50061) which is highly recommended for the shortwave listener. It provides an introduction to shortwave radio for the beginner and presents some of the more practical aspects and advice for the more experienced listener.

S-METER READINGS

The front panel illuminated S-Meter provides a means of measuring the relative strength of all incoming signals. These meter readings are only correct when the RF GAIN control is fully clockwise. The S-Meter is directly calibrated in "S" units from 1 to 9, and to 30 decibels above S9.

INITIAL CONTROL SETTINGS

Initially the BAND SElector should be switched to the desired frequency range, the Main and Band Spread tuning controls should be set as outlined under "Tuning" and the ANT TRIM control to mid-position. The following chart indicates additional control settings for each mode of operation. Thereafter, the degree of strength or clarity with which signals will be received will depend upon proper readjustment of these controls as outlined under each paragraph for a specific mode.

Table 2. Initial Control Settings

CONTROL	AM RECEPTION	CW RECEPTION	SSB RECEPTION
FUNCTION	AM or AM ANL	CW SSB	CW SSB
RF GAIN	Maximum	Adjust for desired level	Adjust for desired level
BFO	Not in use	Mid-position	Mid-position
AF GAIN	Adjust for desired speaker output level	1/2 Maximum	1/2 Maximum
ANT TRIM	Adjust for maximum signal on maximum background noise		

AM OPERATION (Phone)

For the reception of amateur or broadcast stations, short-wave listening, etc., place all controls in the positions as indicated previously. Tune in station using the Main and Band Spread tuning controls as outlined in the section "Tuning" and adjust the ANT TRIM for highest S-Meter reading of the incoming signal. The antenna control setting is satisfactory while operating over a limited frequency range, therefore when tuning over a wide range of frequencies this control should always be re-peaked at the operating frequency. If excessive spurious noises such as those caused by auto ignition make reception difficult, place the FUNCTION switch in the AM ANL position. The automatic noise limiter (ANL) should be used only when necessary, since it tends to reduce the overall efficiency of the receiver.

CW OPERATION (Code)

The control settings required for the reception of code signals are indicated in the chart. The AF GAIN control should be set to 1/2 to 3/4 maximum, and the RF GAIN control used as a volume control. Tune in the CW signal to "zero beat" and adjust the BFO control to either side of the center dot for the desired pitch.

NOTE: The markings LSB/USB on the BFO scale are insignificant for CW operation. These markings are used only when tuning single sideband stations.

SSB OPERATION (Single Sideband)

In most cases the only stations that will be received operating single sideband will be amateur radio operators. However, some commercial radio stations may also be found operating SSB. Control settings for sideband reception are virtually the same as for CW. Note, however, that LSB (lower sideband) and USB (upper sideband) markings are provided on the BFO scale to permit selection of either sideband as necessary. The sideband that must be selected will usually depend upon the band in use. The lower sideband (LSB) is usually required for SSB stations operation on the lower amateur bands (80 and 40 meters) whereas the upper sideband (USB) is usually required for stations operating on the higher bands (20, 15 and 10 meters).

The AF GAIN control is set to 1/2 to 3/4 maximum, and the RF GAIN is used to adjust the signal level. With the main tuning pointer set to the desired band, tune station in with the BAND SPREAD control and then adjust the BFO control in the direction for either LSB or USB until clarity of speech is obtained. If the speech remains garbled and cannot be clarified, select the other sideband and retune slowly. You may have made an error in sideband selection, or the station may be transmitting a sideband other than the one used in the band. Slight readjustment of the BAND SPREAD may be necessary to provide best audio quality.

RETURNING THE UNIT FOR REPAIR

In the event that repair is necessary (either in or out of warranty), we recommend that you return the receiver to the Lafayette store from which it was purchased. If the unit is to be shipped to our main service center for service, please read the instructions which follow.

SHIPPING INSTRUCTIONS

Pack the unit very carefully to avoid damage in transit, preferably in its original carton. If the original carton is not available, use a sturdy carton with least 3 inches of shredded paper or excelsior around the unit. In the latter case, wrap the unit in paper first to avoid particles of packing material getting into it. Include with the unit a letter explaining exactly what difficulties you have encountered [remember to add extra First Class postage and indicate on the outside of the carton that First Class-Mail is enclosed]. Ship by prepaid express if possible and mark ELECTRONIC EQUIPMENT — FRAGILE. Clearly address the carton as follows:

SERVICE DIVISION
LAFAYETTE RADIO ELECTRONICS CORP.
150 Engineers Road
Hauppauge, L.I., N.Y. 11787

SERVICE INFORMATION

DIAL CORD STRINGING

Set the Main or Band Spread tuning capacitor indicated. It should be noted that the illustrations are viewed from the rear of the chassis. In either case (Main or Band Spread) tie one end of the dial cord to the spring at the starting point and restring in the direction indicated with moderate tension. Applying a firm tension on the dial cord, make final tie at the point shown on the drawing. Cut away all excess dial cord.

NOTE: Due to the variable capacitor plates having to be fully opened, extreme care should be exercised while stringing the new dial cord.

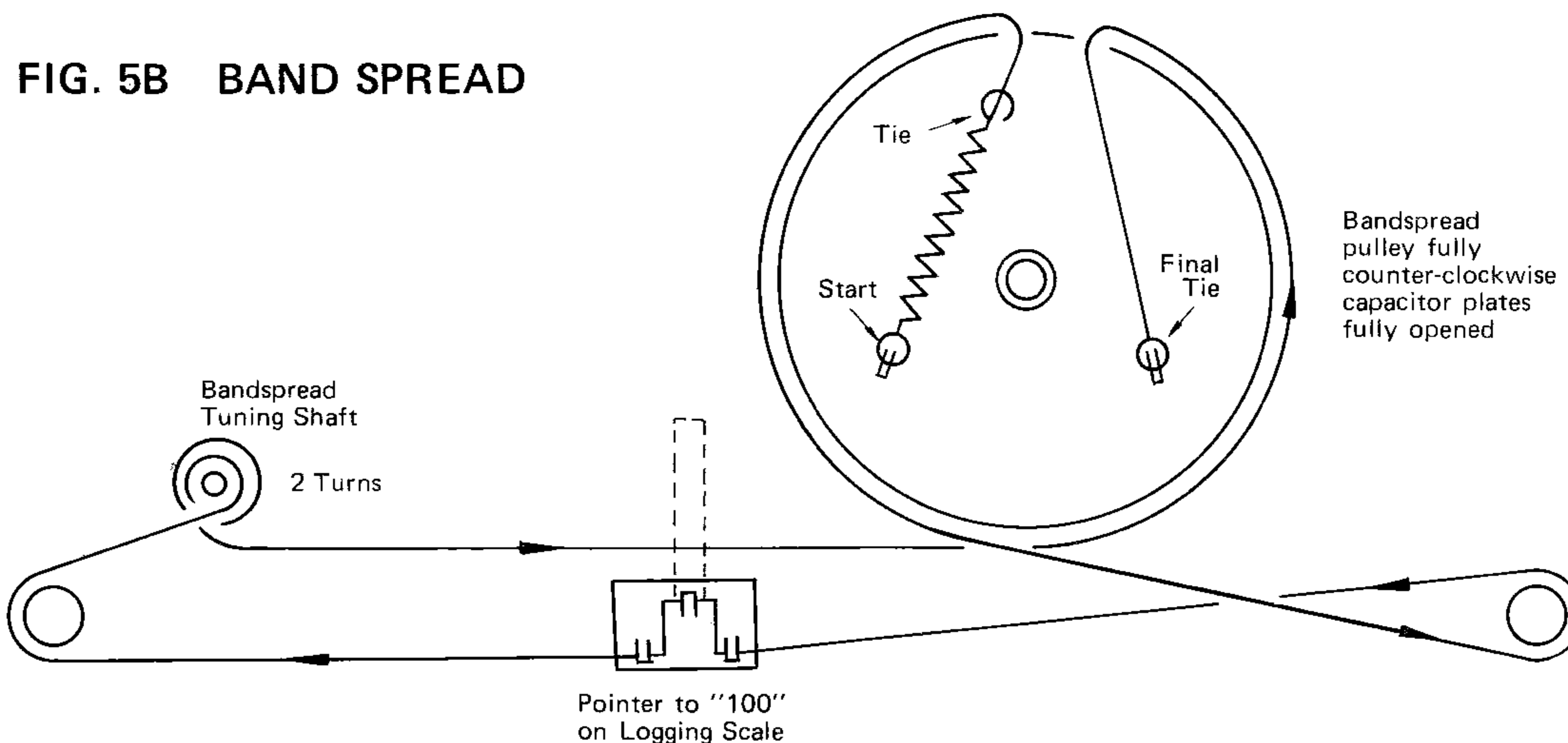
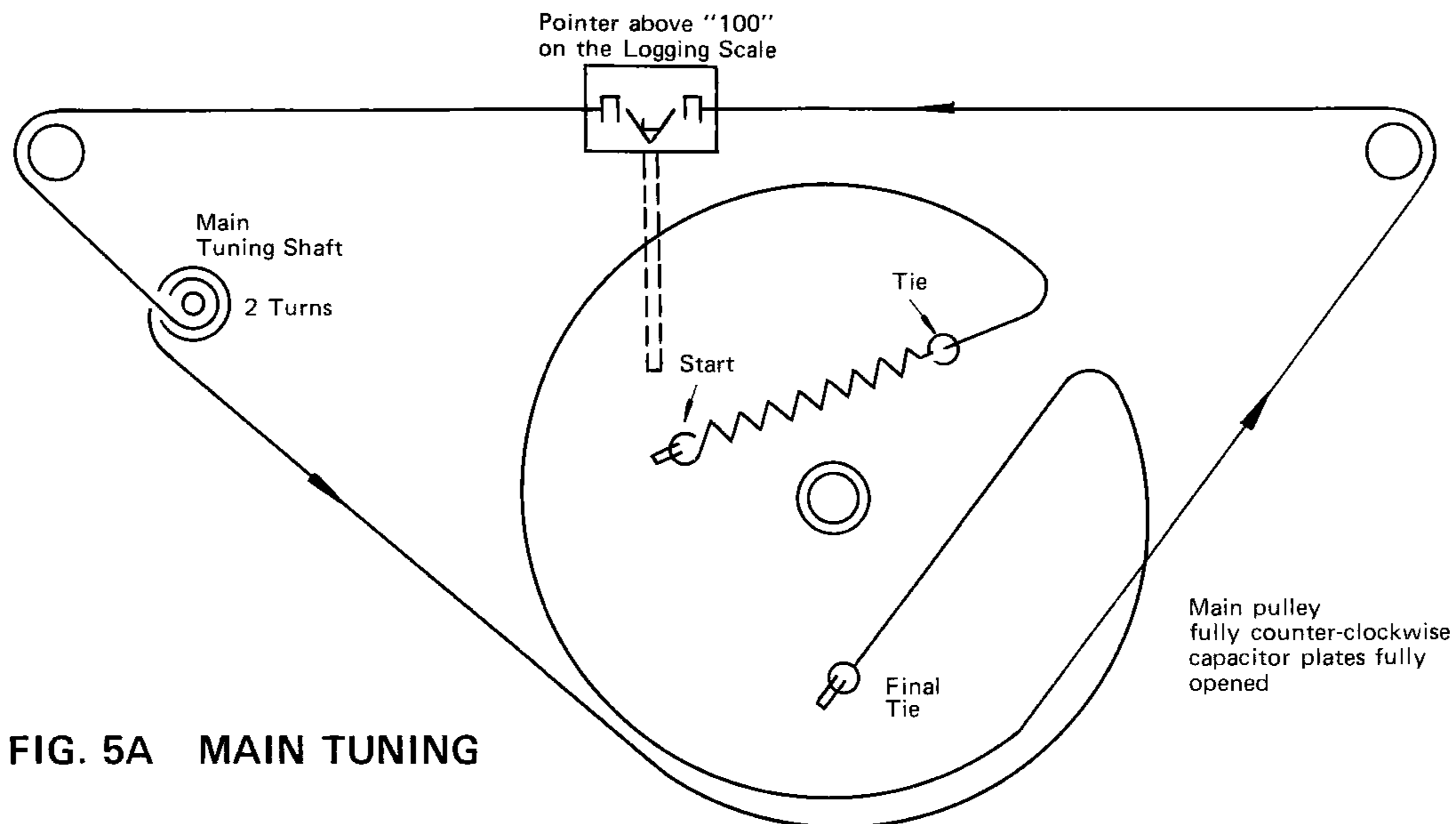

Table 3. Alignment Char

STEP	INPUT SIGNAL AND S.G. COUPLING	BAND SELECTOR	MAIN TUNING DIAL SETTING	ADJUST	OUTPUT INDICATION
IF and mechanical filter alignment	455 KHz at Point "A" on VC-1 (topside)	.55 - 1.6	.55 MHz	MF-1, L16 (underside), L17, L19 (topside). Adjustments should be repeated several times to insure that all adjustments are peaked at 455 KHz	Maximum output
RF alignment (S.G. across antenna terminals) See note below	.16 MHz (160 KHz) .38 MHz (380 KHz) .25 MHz (250 KHz)	0.15 - 0.40	.16 MHz .38 MHz .25 MHz	L11 (Osc) L6 (Mixer) CT-6 (Osc) CT-1 (Mixer) L1 (Ant)	on AC
	.6 MHz (600 KHz) 1.4 MHz (1400 KHz) 1.0 MHz (1000 KHz)	0.55 - 1.6	.6 MHz 1.4 MHz 1.0 MHz	L12 (Osc) L7 (Mixer) CT-7 (Osc) CT-2 (Mixer) L2 (Ant)	Voltmeter (connected
	1.8 MHz (1800 KHz) 4.0 MHz (4000 KHz) 2.5 MHz (2500 KHz)	1.6 - 4.8	1.8 MHz 4.0 MHz 2.5 MHz	L13 (Osc) L8 (Mixer) CT-8 (Osc) CT-3 (Mixer) L3 (Ant)	across
	5.0 MHz 14.0 MHz 8.0 MHz	4.8 - 14.5	5.0 MHz 14.0 MHz 8.0 MHz	L14 (Osc) L9 (Mixer) CT-9 (Osc) CT-4 (Mixer) L4 (Ant)	speaker
	11.0 MHz 29.0 MHz 16.0 MHz	10.5 - 30	11.0 MHz 29.0 MHz 16.0 MHz	L15 (Osc) L10 (Mixer) CT-10 (Osc) CT-5 (Mixer) L5 (Ant)	output terminals).
BFO*	455 KHz (unmodulated) across antenna terminals	.55 - 1.6	.55 MHz	L20 (ropside)	Zero beat (minimum reading on AC Voltmeter).
S-METER	7.0 MHz (100 μ V level) across antenna terminals	4.8 - 14.5	7.0 MHz	RV-3	"S-9" on front panel S-meter.

* Switch FUNCTION control to CW SSB position, and BFO control to center position.

Note: All "Osc" and "Mixer" adjustments should be repeated for each band until calibration is correct at both ends of the dial.

1. On all bands, the oscillator should be set on the high frequency side of the incoming signal.
2. Unless otherwise specified, the signal generator should be set for 400 Hz 30% modulation at the alignment frequency.
3. L18 has been factory-adjusted for maximum rejection of 455 KHz and does not usually need re-adjustment.

ALIGNMENT

The Model HA-600A has been fully aligned and calibrated at the factory and, with normal usage, will not require further adjustment. Service or replacement of major components may require subsequent realignment, but under no circumstances should realignment be attempted unless the malfunction has been analyzed and definitely traced to mis-alignment. Alignment should only be performed by persons experienced in this work, using the proper test equipment. Unless otherwise stated, the bandspread pointer should be set at "100" and all other controls should be set as outlined under "Initial Control Settings" for AM reception. The ANT TRIM control should be set to its center position and left there during alignment.

Do not make any adjustments unless the operation of this unit is fully understood and adequate test equipment is available. Refer to Figure 6 for the location of all alignment points.

COVER REMOVAL

Remove the four screws on the sides of the receiver and remove the top cover. During RF alignment (adjustments on underside of unit) the procedure should be followed with the bottom cover in place. Access holes have been provided on the bottom plate for slug and trimmer adjustments. If it becomes necessary to remove the bottom cover, the six screws should be removed.

TEST EQUIPMENT REQUIRED

Calibrated RF Signal Generator, AC Voltmeter or VTVM and Non-metallic alignment tools.

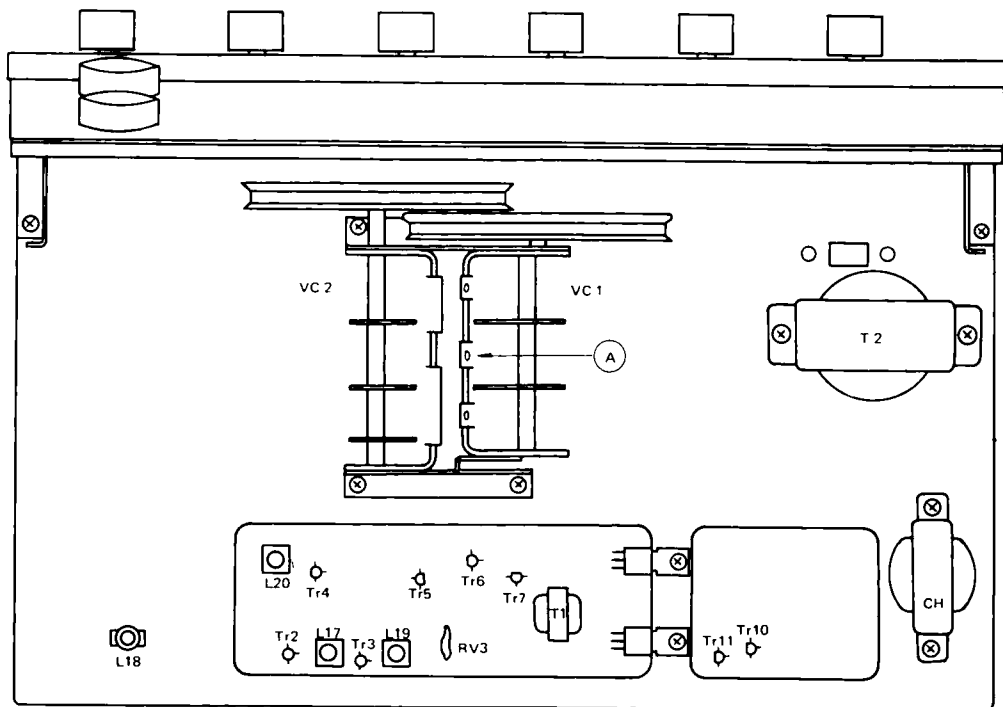

L18 factory-set for max 455 KHz rejection, and does not require re-adjustment.

Figure 6. Adjustment Points - Topside

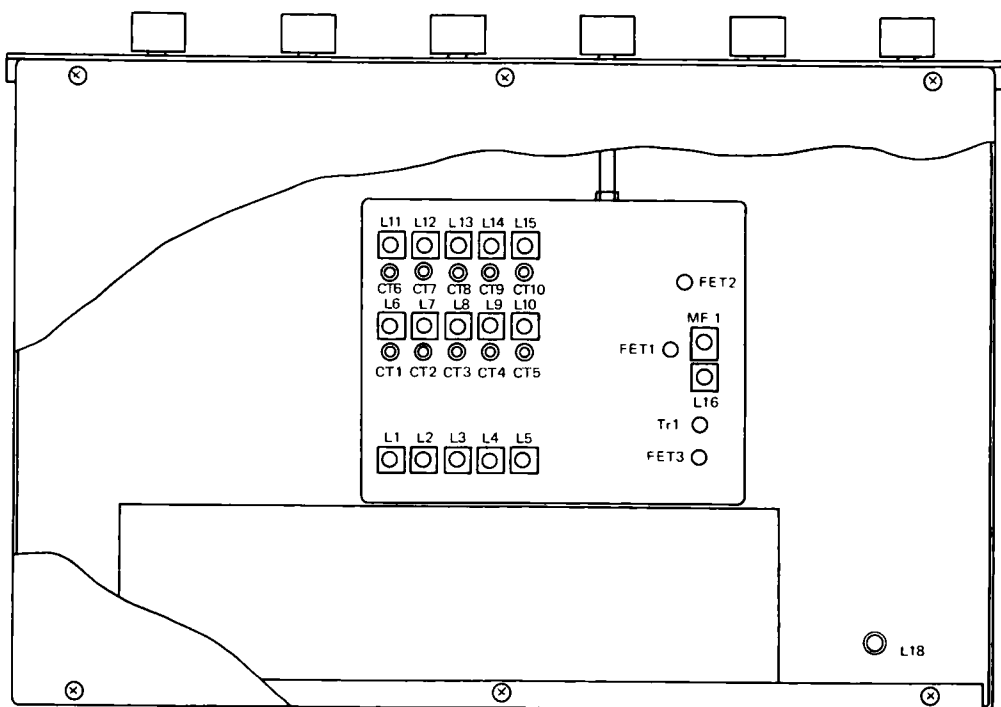
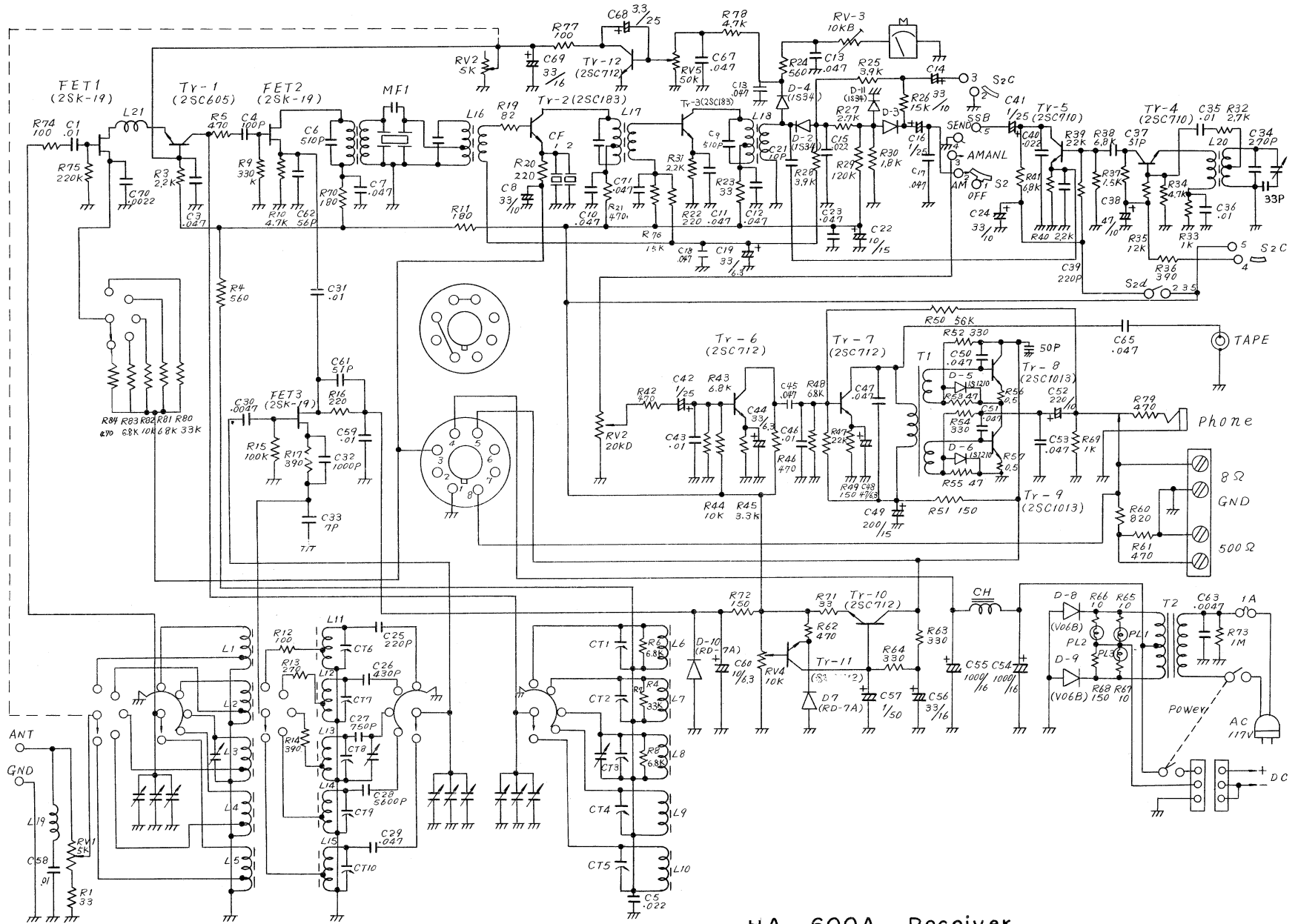
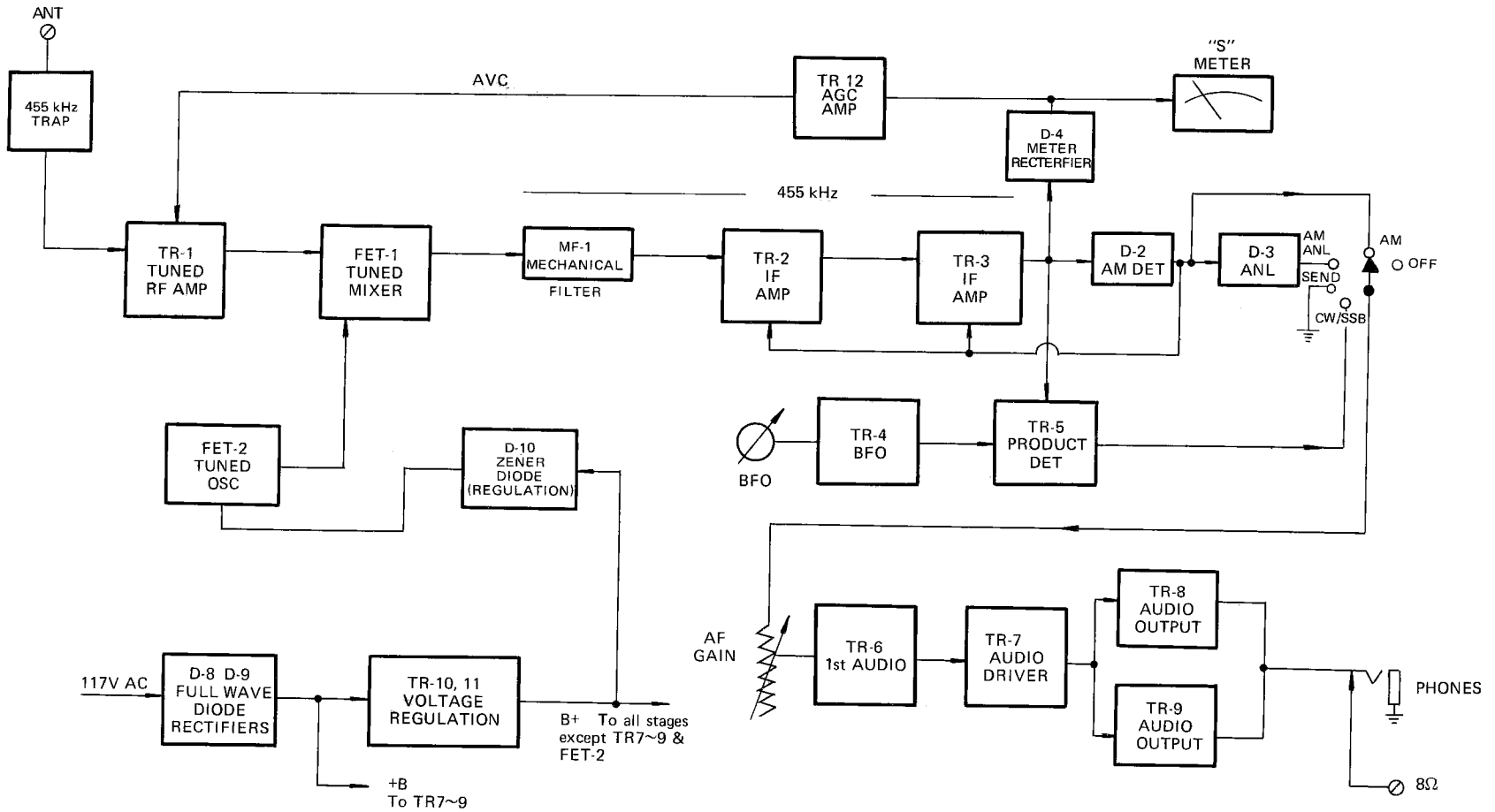

Figure 6. Adjustment Points - Underside



HA-600A Receiver



Functional Block Diagram HA-600A

LAFAYETTE
RADIO ELECTRONICS
CORPORATION

111 JERICO TURNPIKE
SYOSSET, L. I., NEW YORK

(52-02-1500)