

LAFAYETTE

**HA-63**

COMMUNICATIONS  
RECEIVER

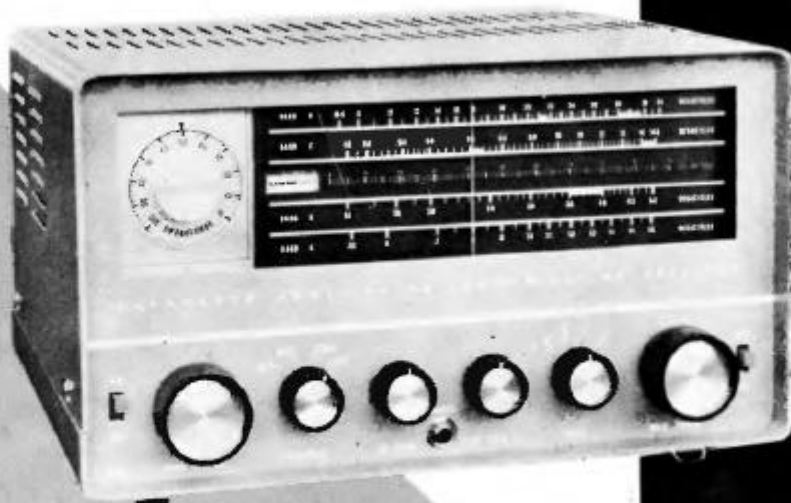

**OPERATING MANUAL**



## TECHNICAL SPECIFICATIONS

|                              |                                                                                                                                                         |
|------------------------------|---------------------------------------------------------------------------------------------------------------------------------------------------------|
| FREQUENCY RANGE .....        | Band A: 0.55 — 1.6 Mc<br>Band B: 1.6 — 4.8 Mc<br>Band C: 4.8 — 14.5 Mc<br>Band D: 10.5 — 31.0 Mc                                                        |
| OPERATION .....              | AM, CW.                                                                                                                                                 |
| INTERMEDIATE FREQUENCY ..... | 455 Kc.                                                                                                                                                 |
| SENSITIVITY .....            | 1 $\mu$ V for 10db S/N ratio.                                                                                                                           |
| SELECTIVITY .....            | 30 db at $\pm$ 10 Kc.                                                                                                                                   |
| ANTENNA INPUT .....          | 50 — 75 ohms, balanced or unbalanced.                                                                                                                   |
| AUDIO OUTPUT .....           | 1.5 watts, 8 ohms impedance.                                                                                                                            |
| AUXILIARY CIRCUITS .....     | Electrical Bandsread<br>Automatic Noise Limiter<br>AVC-MVC<br>BFO<br>"S"-meter                                                                          |
| TUBE COMPLEMENT .....        | V1 6BA6 RF Amp<br>V2 6BE6 Mixer<br>V3 6BE6 HF Osc<br>V4 6BA6 IF Amp<br>V5 6AV6 DET, AVC, ANL & 1st Audio Amp<br>V6 6AV6 BFO<br>V7 6AR5 Audio Output Amp |
| POWER SOURCE .....           | 117 volts, 50/60 cycles AC                                                                                                                              |
| POWER CONSUMPTION .....      | 50 VA                                                                                                                                                   |
| DIMENSIONS .....             | 13" w x 7-4/5" h x 10" d.                                                                                                                               |
| NET WEIGHT .....             | 16 lbs.                                                                                                                                                 |

## INSTALLATION

### POWER SOURCE

The receiver is designed to operate from a 117 volt, 50-60 cycle AC power source. DO NOT OPERATE FROM A DC SOURCE.

### SPEAKER CONNECTION

A two-terminal strip marked SPEAKER is provided at the rear of the receiver for connections to a PM speaker of 8 ohm impedance. Simply connect one lead to the ground terminal "O" and the other lead to the terminal designated 8Ω. The output power of the receiver is sufficient to drive a 4-12 inch speaker adequately.

### HEADPHONES

A standard phone jack is provided on the front panel of the receiver for headphone reception. Low impedance (8-16 ohms) headphones are recommended for optimum results. Insertion of a phone plug into the jack automatically disconnects any speaker attached to the 8 ohm output terminal.

### ANTENNAS

The terminals marked "A1", "A2", and "E" at the rear of the receiver are for antenna and ground connections. Either of the following two types of connections can be used to obtain satisfactory results.

#### INVERTED "L" ANTENNA

The inverted "L" type of antenna will provide satisfactory performance over the entire tuning range. Simply short A2 and E with a jumper wire, and connect one end of the antenna wire to A1. For good reception, the antenna wire should be placed as high as possible and 50-100 feet long (see Fig. 1). In most cases, a wire connected from terminal "E" to a cold-water pipe will improve reception.

#### DOUBLET ANTENNA

A doublet antenna will give excellent results, especially on amateur bands. A 75 ohms balanced transmission line should be used (as shown in Fig. 2). Since the doublet antenna provides optimum performance only at a given frequency, it should be cut to the length for the most often used band of frequencies. The overall length of a doublet antenna can be determined by using the following formula:

$$L \text{ (Length in feet)} = \frac{468}{\text{Frequency in Megacycles}}$$

Since the doublet antenna displays directional properties broadside to its length, it should be installed in such a manner that maximum signal pickup can be realized.

When using either a balanced transmission line or a twisted pair, the leads connect to terminals "A1" and "A2" respectively, and the jumper wire between "A2" and "E" is removed. A height of 30-50 feet is recommended for good reception of weak signals.

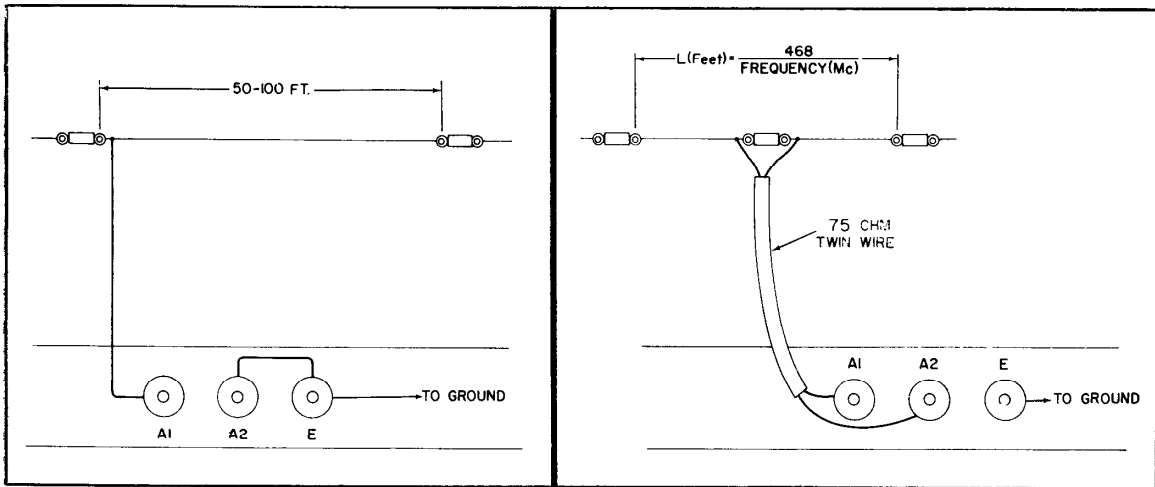

**FIGURE 1** Single Wire Antenna (inverted L)

**FIGURE 2** Doublet Antenna

#### FUSE

A 1 amp fuse is located at the rear of the receiver. To remove it, unscrew the spring loaded cap. Replace only with one of a similar rating.

#### REMOTE SOCKET

A socket in the back of the receiver (REMOTE) allows simultaneous control of this receiver with a transmitter. An external switching device can be used so that the receiver will be inoperative during periods of transmission. In this case, the FUNCTION switch is placed in the REC position. The contacts of the external switch are attached by means of a standard AC plug so that the pins (see Fig. 3) will be connected when signal reception is desired. This plug is then inserted into the REMOTE socket. In this manner, plate voltage will be applied to the RF stages when the switch is closed and signal reception will be instantaneous.

For normal operating conditions with no external switching, place the FUNCTION switch in the REC position, thus providing plate voltage to the RF stages. To manually disable the receiver under these conditions, set the switch to the SEND position. In this position plate voltages to the RF stages are cut off. Returning the switch to REC will provide instantaneous signal reception.

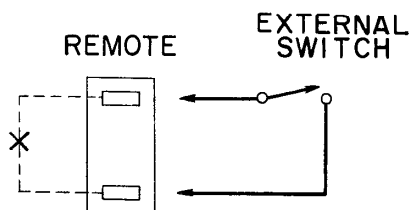

**FIGURE 3**

Disconnect a jumper wire connected internally across REMOTE jack as shown in figure 3 when EXTERNAL SWITCH is used.

## OPERATION

Following is a brief description of the functions of the various controls on the front panel. Full appreciation as well as realization of the capabilities of the receiver can be expected only if you become familiar with each of the control functions.

### FUNCTION

OFF — AC power is removed from the receiver. In all other positions AC power is applied.

REC — Heater and plate voltages are applied and the receiver is able to receive signals.

SEND — This position removes plate voltages to the RF stages, and thus makes the receiver inoperative (see previous section "Remote Socket").

BFO — This position places the beat frequency oscillator in operation for the reception of code signals (CW). The Bandsread control is used to adjust the pitch of the tone produced on CW signals.

### BAND

This switch selects one of the four frequency bands available as follows:

|         |                                 |
|---------|---------------------------------|
| Band A: | 0.55 to 1.6 Mc (550 to 1600 Kc) |
| Band B: | 1.60 to 4.80 Mc                 |
| Band C: | 4.80 to 14.50 Mc                |
| Band D: | 10.50 to 31.00 Mc               |

### MAIN TUNING

This control operates the tuning pointer over the main tuning dial. This dial has four calibrated frequency scales, one for each of the four tuning bands. All frequencies shown are in megacycles (Mc). Band A covers the Broadcast Band (550-1600 Kc). The other three bands cover the short-wave range of 1.6-31.00 Mc. The amateur radio bands are contained within the thicker sections of the white scale lines. Calibrations of these scales are correct only when the Bandsread dial is set to 100.

The main tuning dial also incorporates a 0 to 100 Logging Scale. This may be used to log any particular short-wave station by noting the position of the main tuning pointer on the Logging Scale and also noting the position of the Bandsread dial. A record may then be kept of both numbers so that both Bandsread and Main Tuning can be quickly set to receive any of the short-wave stations logged in this manner.

### BANDSPREAD

This control is used to provide "fine tuning" over small sections of the main tuning scales. This is especially useful on short-wave frequencies where separation between stations is often very small or almost non-existent. When the Bandsread dial is set to 100, the main tuning pointer will indicate the true received frequency. Rotating the Bandsread dial towards 0 subtracts from the frequency indicated by the main tuning pointer.

The Bandsread control can be used in two ways — to provide bandsreading over the amateur bands, or as a fine tuning device to tune in commercial short-wave stations.

### **Bandspreading**

Set the bandspread dial to 100 and the main tuning pointer to the extreme right-hand side (high-frequency end) of the amateur band which you wish to tune. Rotating the BANDSPREAD control towards 0 will now tune over the amateur band selected.

### **Fine Tuning**

Set the bandspread dial to 50 and use the tuning control to set the main pointer to the approximate frequency of the desired station. Now use the bandspread control to locate the station by tuning in either direction — from 50 to 100 and 50 to 0.

### **ANTENNA TRIMMER**

The ANT TRIM control, adjustable from the front panel, acts as a compensating capacitor to permit optimum matching of the receiver to the antenna at all frequencies. Initially, the control should be set to its mid-position (the dot on the front surface of the knob at 12 o'clock position). The control should always be adjusted for maximum background noise. Each setting will be good only over a limited range of frequencies. The trimmer should therefore always be readjusted after tuning to the general area where the expected signal is to be found.

### **AF GAIN**

This adjusts the audio output level in the speaker or headphones.

### **AVC-MVC**

This switch, when set to the AVC position, places the automatic volume control circuit in operation, and provides effective compensation for fading and maintains relatively constant output on either strong or weak signals. The MVC position makes the AVC circuit inoperative and should be used only when added sensitivity is required during the reception of weak signals. If MVC is used with strong signals, overloading and distortion will occur. Note that the S-meter is also inoperative in the MVC position.

### **ANL**

This switch should be normally set at "OFF". If excessive spurious noises (such as those caused by auto ignition) interfere with reception, turn the switch to "ON", and the automatic noise limiter circuit will be in operation. This control should be used only when necessary, since it tends to reduce the overall efficiency of the receiver.

### **S-METER**

This meter, calibrated in "S" units from 1 to 9, provides a means of measuring the relative strength of incoming signals. It is operative only when the MVC-AVC switch is in the AVC position. An adjustment control at the rear of the receiver permits calibration of the meter, as follows: Remove antenna so that there is no signal input to the receiver and adjust the "S" meter Adjust control for a zero reading on the meter.

NOTE: Initial application of AC power to the receiver (from OFF to REC) may cause the pointer to swing to the extreme right (full-scale) position. After warm-up, however, the pointer will return to its normal operating position.

## OPERATING INSTRUCTIONS

The following chart indicates the initial settings of the various controls for each type of operation. Thereafter, the degree of strength or clarity with which signals will be received will depend upon proper readjustment of the various controls.

### INITIAL CONTROL SETTINGS

| CONTROL  | AM OPERATION                                             | CW OPERATION                                             |
|----------|----------------------------------------------------------|----------------------------------------------------------|
| FUNCTION | REC                                                      | BFO                                                      |
| BAND     | Set for band which includes desired range of frequencies | Set for band which includes desired range of frequencies |
| ANT TRIM | 12 o'clock position                                      | 12 o'clock position                                      |
| AVC-MVC  | AVC                                                      | MVC                                                      |
| ANL      | OFF                                                      | OFF                                                      |
| AF GAIN  | Adjust for desired audio output                          | Adjust for desired audio output                          |

#### AM OPERATION

For the reception of broadcast stations, short-wave listening, etc., place all controls in the positions indicated in the Initial Control Settings chart. Tune in station, using Main and Bandsread tuning controls as indicated in a previous section describing the functions of MAIN TUNING and BAND SPREAD controls. Adjust ANT TRIM for highest "S" meter reading on signal or for maximum background noise. If excessive spurious noises such as those caused by auto ignition make reception difficult, place the ANL OFF switch to the ON position.

#### CW OPERATION

The control settings required for the reception of CW (code signals) are the same as for AM except that the Function switch is now set to BFO to produce the necessary tone. When tuned to the exact frequency of the CW signal, a "zero beat" or "null" will be heard. Detuning slightly in either direction (higher or lower in frequency) will produce a "beat" note. The Bandsread control can therefore be used to vary the tone and provide clearest reception of the desired CW signal.

## SHORT-WAVE LISTENING

On the short-wave frequencies are to be found radio stations transmitting from all over the world. Many of these stations provide English-language broadcasts. The frequencies on which the majority of short-wave broadcast stations operate are found in the two upper bands of your receiver (4.8 to 14.5 megacycles and 10.5 to 31 megacycles). A characteristic of short-wave is that reception varies with the time of day, the season of the year and with weather conditions. In order to know just when and where to listen, a listening chart which lists English language broadcast stations best heard in North America is included in this manual.

"Better Shortwave Reception" by William I. Orr (available from Lafayette Radio as BK1032) is recommended to the short-wave listener and amateur alike. It provides an introduction to short-wave radio for the beginner and presents some of the practical aspects and helpful advice for the more experienced listener.

## SERVICE

This section contains information which will aid qualified service personnel in the servicing and alignment of your receiver.

### CHASSIS REMOVAL

The top cover is held by four screws — two each side. The bottom cover is held by six screws on the underside of the unit.

## IF ALIGNMENT

### EQUIPMENT REQUIRED:

AC Voltmeter  
Calibrated RF Signal Generator  
Non-Metallic Alignment Tools

Refer to the diagram which shows the location of IF adjustment points.

1. Connect a loudspeaker to the output terminals. Remove the oscillator V3, 6BE6, from its socket.  
WARNING: Make sure the tube retaining clip does not slip down and cause a short-circuit on the underside of the chassis.
2. Set the receiver controls as follows:
  - FUNCTION switch on REC
  - AF GAIN control to maximum
  - MVC-AVC switch on MVC
  - ANL off
  - Band to A
  - Main Tuning pointer to 1.6 Mc.
3. Connect the voltmeter (3 volt AC range) across the speaker terminals.
4. Connect the signal generator between pin 7 of V2 socket (6BE6 mixer tube) and ground (chassis).
5. Set the signal generator at 455 Kc and modulate it with either 400 or 1000 cycles (30%).
6. Adjust the secondary and primary of IF transformers T2 and T1. Follow the order given — secondary first, then primary in each case. Topside adjustments are secondaries, bottom of chassis adjustments are primaries.

During alignment, lower the generator output progressively to prevent overloading. Repeat alignment until no further improvement is noted.



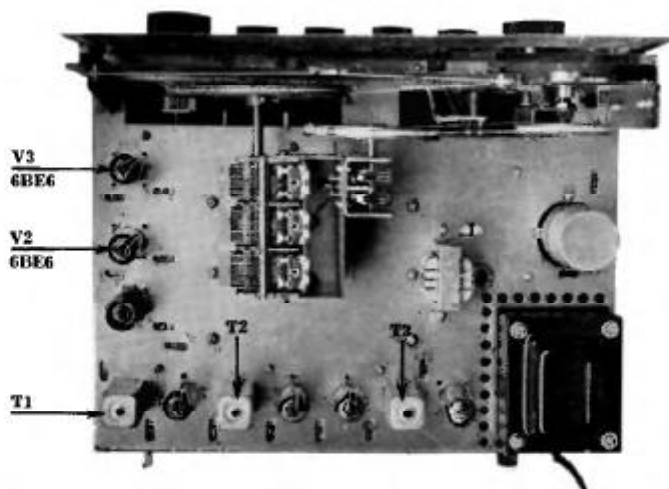

IF ALIGNMENT — TOPSIDE ADJUSTMENT POINTS

### BFO ADJUSTMENT

1. All receiver controls should be set as in the IF alignment with the exception of the following:  
     FUNCTION switch to BFO  
     Reduce AF GAIN
2. Set the generator to 455 Kc, unmodulated RF.
3. Adjust the BFO coil T3 until a zero beat is heard (also accompanied by a minimum reading on the voltmeter. Note that the minimum point will be bracketed by a peak on each side).
4. Switch off and disconnect AC power to the receiver. Also, remove connections from the generator.
5. Replace V3, 6BE6 oscillator.
6. Replace top and bottom covers on the receiver.

### RF ALIGNMENT

1. Switch receiver on and allow it to warm up for approximately 15 minutes.
2. Using a short jumper wire, connect antenna terminals A2 and E together.
3. Connect AC voltmeter (3 volt range) and loudspeaker across speaker terminals.
4. Connect the modulated output of the RF signal generator to antenna terminals A1 and E.
5. Rotate the ANT TRIM control until the capacitor plates are half meshed. If the indicator dot on control knob is not at the 12 o'clock position, loosen set screw, place knob in this position and tighten screw again (without disturbing position of capacitor plates). Do not change control from the 12 o'clock position until alignment is completed.
6. Set all receiver controls as for IF alignment. Set BANDSPREAD dial to 100 and make sure FUNCTION switch is on REC.
7. Carry out alignment as indicated in the chart. Use the diagram provided which shows RF adjustment points on the underside of the receiver.

NOTE: Lower generator output progressively to prevent overloading as circuits come into line.

## RF ALIGNMENT CHART

| STEP                                                                                          | BAND SWITCH | SIGNAL GENERATOR | MAIN TUNING | ADJUST     | REMARKS                              |
|-----------------------------------------------------------------------------------------------|-------------|------------------|-------------|------------|--------------------------------------|
| 1                                                                                             | A           | .6 Mc (600 Kc)   | .6 Mc       | CO5 (Osc)* | Adjust for peak reading on voltmeter |
| 2                                                                                             | A           | 1.4 Mc (1400 Kc) | 1.4 Mc      | CO4 (Osc)  |                                      |
| Repeat steps 1 & 2 until calibration is correct at both ends of scale (.6 and 1.4 Mc)         |             |                  |             |            |                                      |
| 3                                                                                             | A           | 1.4 Mc (1400 Kc) | 1.4 Mc      | CM4 (RF)   | Adjust for peak reading on voltmeter |
| 4                                                                                             | B           | 2.0 Mc           | 2.0 Mc      | LO3 (Osc)  |                                      |
| 5                                                                                             | B           | 4.0 Mc           | 4.0 Mc      | CO3 (Osc)  |                                      |
| Repeat steps 4 & 5 until calibration is correct at both ends of the scale (2.0 and 4.0 Mc)    |             |                  |             |            |                                      |
| 6                                                                                             | B           | 2.0 Mc           | 2.0 Mc      | LM3 (RF)   | Adjust for peak reading on voltmeter |
| 7                                                                                             | B           | 4.0 Mc           | 4.0 Mc      | CM3 (RF)   |                                      |
| Repeat steps 6 & 7 until calibration is correct at both ends of the scale (2.0 and 4.0 Mc)    |             |                  |             |            |                                      |
| 8                                                                                             | B           | 2.0 Mc           | 2.0 Mc      | LA3 (Ant)  | Adjust for peak reading on voltmeter |
| 9                                                                                             | C           | 5.0 Mc           | 5.0 Mc      | LO2 (Osc)  |                                      |
| 10                                                                                            | C           | 14.0 Mc          | 14.0 Mc     | CO2 (Osc)  |                                      |
| Repeat steps 9 & 10 until calibration is correct at both ends of the scale (5.0 and 14.0 Mc)  |             |                  |             |            |                                      |
| 11                                                                                            | C           | 5.0 Mc           | 5.0 Mc      | LM2 (RF)   | Adjust for peak reading on voltmeter |
| 12                                                                                            | C           | 14.0 Mc          | 14.0 Mc     | CM2 (RF)   |                                      |
| Repeat steps 11 & 12 until calibration is correct at both ends of the scale (5.0 and 14.0 Mc) |             |                  |             |            |                                      |
| 13                                                                                            | C           | 5.0 Mc           | 5.0 Mc      | LA2 (Ant)  | Adjust for peak reading on voltmeter |
| 14                                                                                            | D           | 12.0 Mc          | 12.0 Mc     | LO1 (Osc)  |                                      |
| 15                                                                                            | D           | 26.0 Mc          | 26.0 Mc     | CO1 (Osc)  |                                      |
| Repeat steps 14 & 15 until calibration is correct at both ends of scale (12.0 and 26.0 Mc)    |             |                  |             |            |                                      |
| 16                                                                                            | D           | 12.0 Mc          | 12.0 Mc     | LM1 (RF)   | Adjust for peak reading on voltmeter |
| 17                                                                                            | D           | 26.0 Mc          | 26.0 Mc     | CM1 (RF)   |                                      |
| Repeat steps 16 & 17 until calibration is correct at both ends of scale (12.0 and 26.0 Mc)    |             |                  |             |            |                                      |
| 18                                                                                            | D           | 12.0 Mc          | 12.0 Mc     | LA1 (Ant)  | Adjust for peak reading on voltmeter |

\*NOTE: On all bands, the oscillator is set on the high frequency side of the incoming signal.

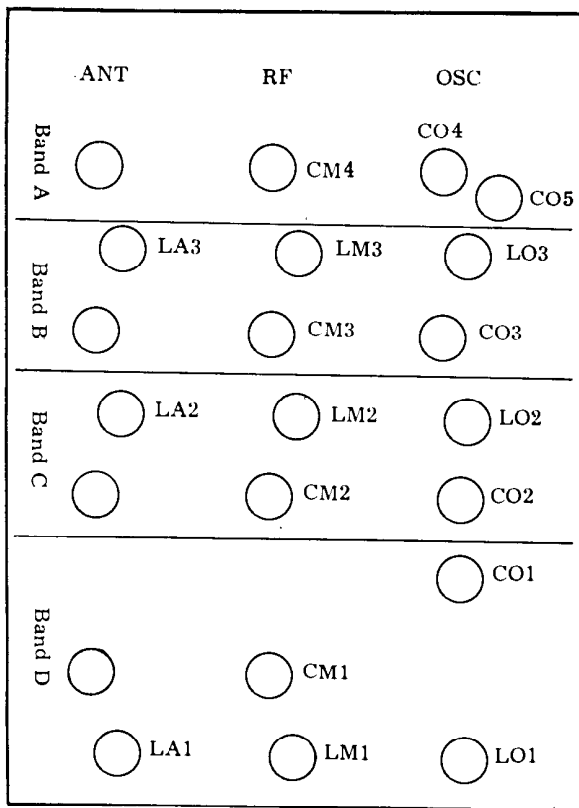

## RF ALIGNMENT

UNDERSIDE ADJUSTMENT POINTS

## DIAL CORD STRINGING

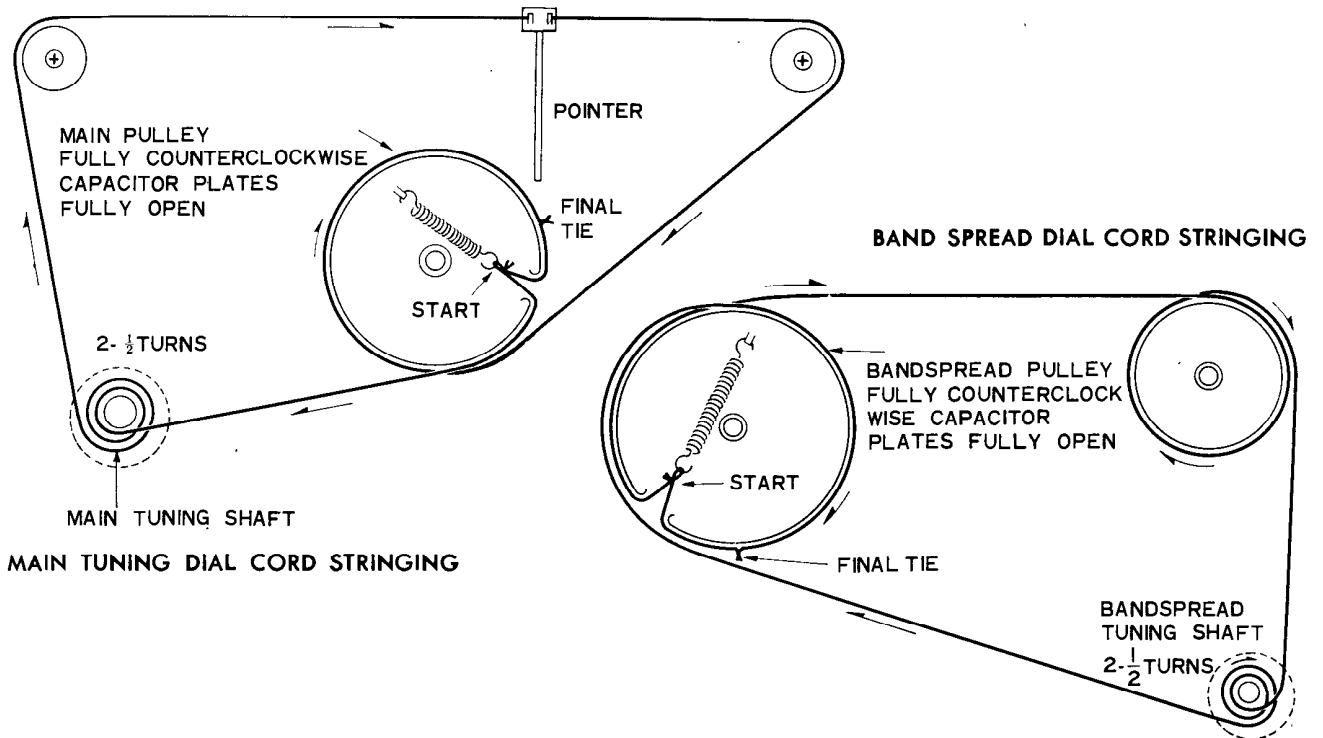

# SCHEMATIC DIAGRAM

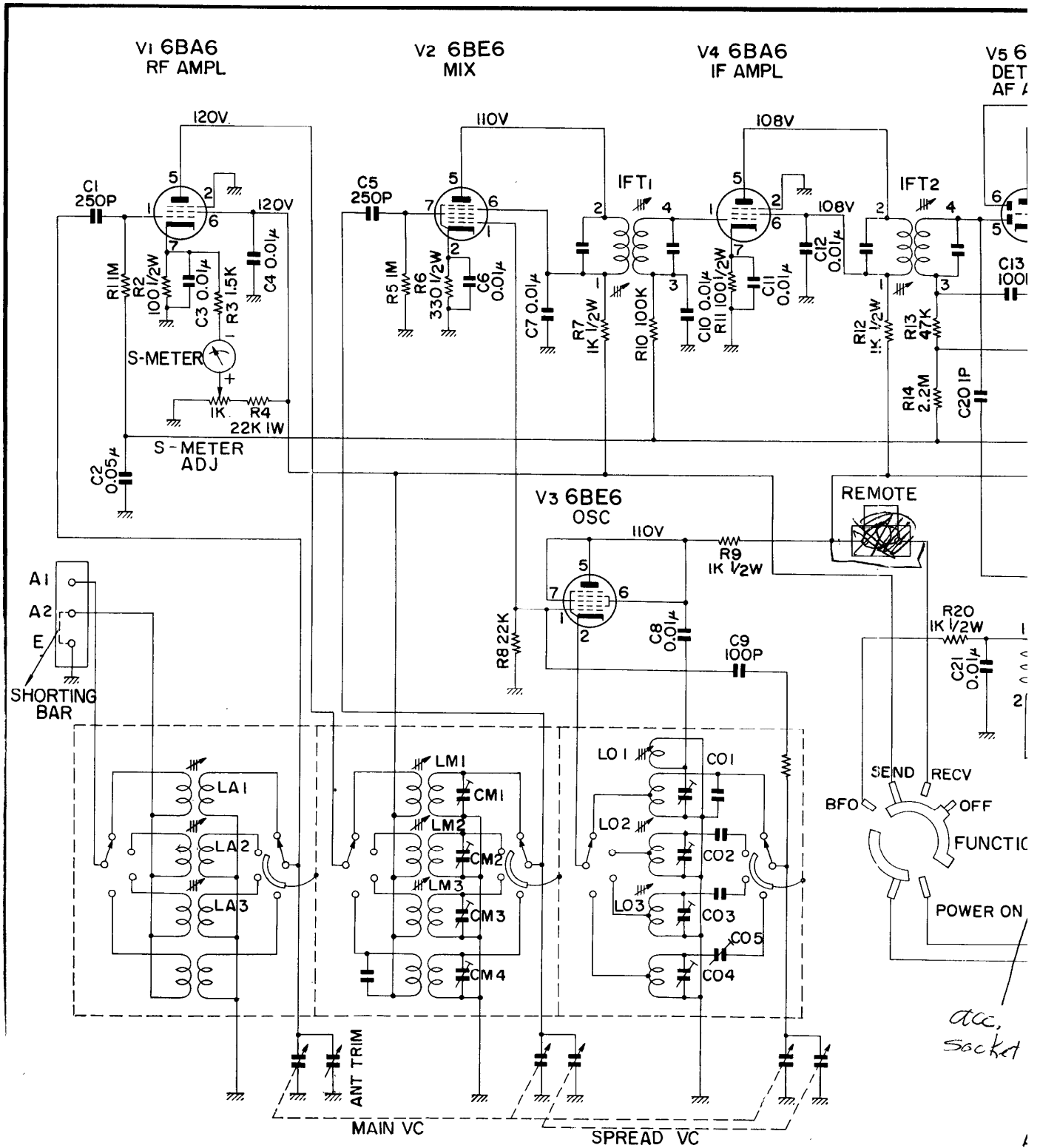

# ATIC DIAGRAM

