

INSTRUCTION MANUAL
FOR

MORROW

TRANSMITTER

MODEL

MB 560

COMPACT, MOBILE OR FIXED STATION,
PHONE OR CW TRANSMITTER



For 6 volt operation, the power supply is equipped with a Mallory 659 vibrator.
For 12 volt operation, the power supply is supplied with a Mallory G659 vibrator. These vibrators are much quieter in operation than a compromise type. When changing from 6 to 12 volt operation or vice versa the vibrator type must be changed. The following are recommended:

For 6 volts use Mallory 659 vibrator

For 12 volts use Mallory G659 vibrator

Universal voltage vibrator types which can be used are the Mallory 4501 and 1501. These two vibrator types can be used inter-changeably on 6 or 12 volts.

INSTRUCTIONS FOR CHANGING MORROW MODEL RVP-250
POWER SUPPLY FROM 6 TO 12 VOLT OPERATION

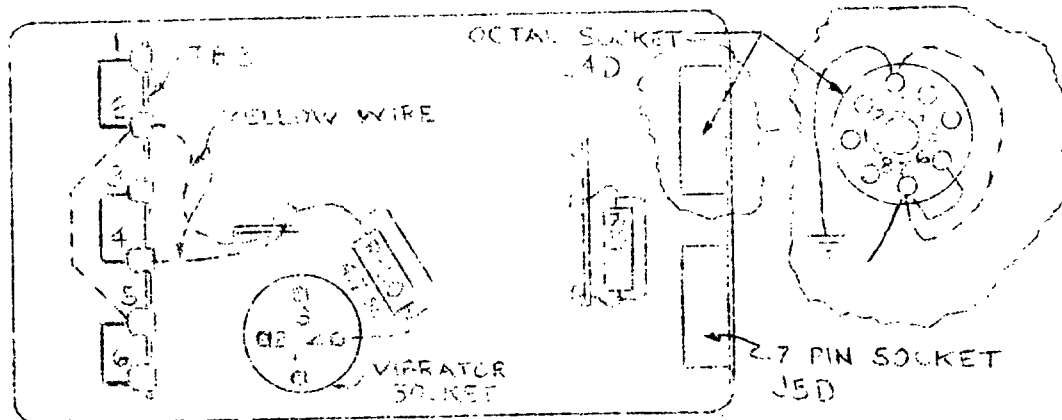

Bottom view power supply

TO CHANGE FROM 6 VOLT TO 12 VOLT OPERATION:

1. Remove jumper from terminals 1 and 2, TB3.
2. Remove jumper from terminals 3 and 4, TB3.
3. Remove jumper from terminals 5 and 6, TB3.
4. Move yellow wire (between R50 and TB3) from terminal 4 to terminal 2. (Dashed line-----).
5. Place #14 wire jumper from terminal 2 to terminal 5 (dashed line-----).
6. Remove jumper from R-50.
7. Remove jumper from R-51.
8. Remove wire from pin 3 (octal socket J4D) to common ground lug.
9. Remove jumper between pins 6 and 7 on socket J4D.
10. Add jumper from pin 3 to pin 7 on socket J4D. (Dashed line -----).

TO CHANGE BACK TO 6 volt OPERATION, REVERSE PROCEDURE.

Note: If power supply is used to supply exciter voltage, jumper between pins 2 and 3, J5D, must be removed. Power to receiver and exciter is controlled by an external transmit-receive switch or relay, connected as shown in sketch.

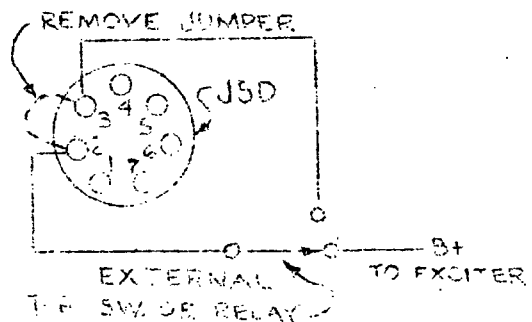

MORROW MB-560 TRANSMITTER
SPECIFICATIONS

1. FREQUENCY RANGE:

3.5-4.0 MC	7.0-7.3MC	14.0-14.35MC
21.0-21.45MC	28.0-29.7MC	
2. FREQUENCY CONTROL:

Variable frequency oscillator or Crystal oscillator.
Calibrated dial scale for each frequency range.
3. POWER INPUT:

6 VDC at 6 Amp. or 12 VDC at 3 Amp.
67.5 VDC at .1 MA
250 VDC at 90 MA.
300 to 600 VDC at 200 MA.
4. POWER OUTPUT:

3.9 MC 50 watts, 29 MC 40 plus watts.
5. OUTPUT NETWORK AND IMPEDANCE:

52-70 ohm pi network.
6. ANTENNA SWITCH;

Antenna switched from receiver to transmitter by built-in relay that is actuated by microphone push to talk switch.
7. TYPE OF SPEECH AND MODULATORS:

High level plate and screen modulation with restricted frequency range and high quality unrestricted range, selected by switch.

 - A. Restricted frequency range:
 - a. Modulation limiting:

Low level clipping and filtering. Modulation limited to 100% with inputs 10 DB above minimum requirement for 80% modulation.
 - b. Modulation frequency range:

Flat plus or minus 1 1/2 DB from 300 cycles to 2500 cycles. Down 40 DB at 200 cycles and down 40 DB at 3100 cycles. First sideband removed from audio frequency range down 30 DB and second sideband down 48 DB.
 - c. Type of microphone:

Carbon microphone recommended. N1 or F1 telephone unit. Morrow Model MK-N1 is designed specifically for use with the MB-560.
 - B. High quality unrestricted range.
 - a. Modulation limiting: none.

- b. Modulation frequency range: Unrestricted, 100 cycles to 10,000 cycles or better.
- c. Microphone recommended: Crystal or dynamic with push to talk switch in base.

8. DIMENSIONS AND WEIGHT:

10 3/4 pounds less power supply

Size overall: Height 4 1/8 Width 11 7/8 Depth 9 3/8

9. MOUNTING HARDWARE:

Drawer type slides.

MORROW MB-560 GENERAL DESCRIPTION

1.0 V.F.O. 12AT7

The Variable frequency oscillator is of the series tuned type or the Clapp oscillator. The oscillator is always operating on one half the carrier frequency, ie, when the transmitter is operating on 3900 KC the oscillator is on 1950KC.

- 1.1 With the oscillator operating on one half the carrier frequency, five oscillator ranges are needed to cover the five bands, 10-15-20-40-75 meters. The five ranges allow the dial to be calibrated over its' full length for each band.
- 1.2 The calibration on each band is very close to the indicated frequency on the dial because the inductance and capacity are adjustable for each range. Each range also is individually temperature compensated for a wide range of temperature variation.
- 1.3 As in the case of most frequency meters, a calibration control is provided to allow the precise setting of the dial calibration. This control is on the front panel and is identified by the panel marking CAL.
- 1.4 To set the calibration, tune a signal of known frequency on the receiver. Set the transmitter dial pointer to this frequency. Adjust CAL until zero beat is obtained.
- 1.5 The oscillator is coupled to the following stage by a small mica capacitor C9. The isolation of the oscillator is complete because of the design of the next stages.

2.0 Cathode follower 6AN8/2

The output of the oscillator is fed to the grid of the cathode follower. This stage helps isolate the VFO from the balance of the transmitter and makes possible excellent oscillator stability. The cathode follower also changes the high impedance of the oscillator to a low impedance for driving and stabilizing the class A stage that follows.

3.0 Crystal Oscillator 12AT7/2

This oscillator is of the modified Pierce type and is used for frequency control where net operation is desired, for novice operation, CD and other special services.

3.1 The oscillator uses crystals that are ground for 1750-2000 KC, 3500-4000 KC, 7000-7425 KC and 10500-10725 KC. The chart below shows the recommended crystals to use with the different bands.

3500-4000 KC	use crystal in 1750-2000, 3500-4000KC
7000-7300 KC	use crystal in 3500-3650, 7000-7300KC
14000-14350KC	use crystal in 7000-7175KC-----
21000-21450KC	use crystal in 10500-10725KC-----
28000-29700KC	use crystal in 7000-7425KC-----

3.4 The output of the crystal oscillator is coupled to the cathode of the cathode follower and in turn is coupled to the grid of the next stage.

4.0 Class A Amplifier 6AN8/2

The class A amplifier is used to further isolate the VFO from the balance of the transmitter. This stage operates straight through on the oscillator frequency. The amplifier is stabilized by operating its' grid circuit from the low impedance of the output of the cathode follower.

4.1 The plate circuit is tuned by the second section of the VFO tuning condenser. On 75 meters the plate is coupled to the next stage without tuning and an RF choke is used for the plate load. On the four higher frequency bands separate adjustable coils with tuning taps to allow for tracking, couple the selected frequency to the following driver doubler.

5.0 Driver Doubler 5763

The driver doubler is a power sensitive tube, requiring small input voltages to deliver at all times ample power to the grid of the following tube.

5.1 While its' prime function is a driver, it also doubles the frequency to the carrier frequency. The tuning of the output circuit is done by the grid coils of the following stage. The oscillator frequency is not effected by the drive level setting of this tube for the next stage, nor by its' tuning.

5.2 Transmitter keying is in the cathode circuit. A key click filter should be installed on the key when CW operation is desired. See diagram below, 5.4

5.3 The drive level control adjusts the screen voltage for the required grid current on the following power amplifier. The drive across the band is constant and when set, needs no further attention. When bands are

changed, resistors are cut into the screen circuit to approximately set the drive level and the control is adjusted for a grid current of 3MA.

5.4 2.5 Millhenry Secondary 5000-ohm 3.4-ohm Output Transformer

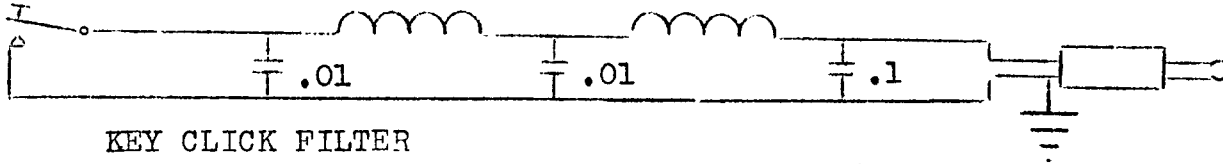

KEY CLICK FILTER

6.0 Power Amplifier 6146

Because of its small size and excellent operating characteristics, a 6146 was chosen for the power output tube. The tube is operating as a completely stable circuit with no interaction between the output tuning and the grid circuit.

- 6.1 The cathode circuit carries the metering for the plate current. A 4.7 ohm resistor in series with the cathode, allows a voltage drop that is a function of the plate current. By reading the voltage drop across this resistor with a meter that is calibrated in MA, a plate current reading is obtained. While this reading is the combined plate and screen, for all practical purposes the screen current may be ignored. The cathode is bypassed at four points to keep it as close as possible to ground.
- 6.2 The grid circuit is tuned to the same frequency as the plate and the amplifier at all times runs straight through. The grid tuning is done by the third section of the VFO tuning condenser and the whole exciter is gang tuned, with one control. The tuning condenser either tunes the complete coil (to get the proper LC ratio) or it tunes a tap. The tracking of the tuning on all bands is very close and is possible because of the adjustable cores in each grid coil.
- 6.3 The tube is grid neutralized by the capacitors that bypass the lower end of each grid coil to ground. Each band is separately neutralized and any band may be adjusted without changing the others. The 75 and 40 meter bands are set with fixed condensers while adjustable elements are used for 20-15-10 meters. While it is possible to operate this tube without neutralization, for perfect results it must be neutralized.
- 6.4 The grid bias is partly fixed and partly from the grid leak. When the unit is used for mobile service, a 67.5 volt battery is used. It will be noted that this battery also supplies bias for the modulator. The CFF-ON switch is used to open the battery circuit when OFF to save battery life.
- 6.5 When the transmitter is used with an AC power supply, the bias is furnished from a voltage regulated source.

- 6.6. When the meter switch is in the grid position, the meter is inserted in the grid circuit below the grid leak. A resistor is connected across the meter switch terminals to complete the circuit when the meter reads another function. Full scale on the meter, in the grid current position is 5MA and the meter should read 3 MA, when the drive control is properly adjusted.
- 6.7 The Screen voltage is obtained from the high voltage plate supply after going through the modulation transformer, through a series of dropping resistors.
- 6.8 When the operation switch is in tune position a 100,000 ohm resistor is inserted in the screen circuit. This allows the transmitter to be tuned with the plate current limited to safe values. After the plate tuning condenser is dipped, the meter must be set on CPR before adjusting the loading.
- 6.9 The screen meter should read less than 8MA at all times. The only reason for higher reading, would be in case the drive was too high or the plate loading is too low.
- 6.10 The screen dropping resistors must be adjusted for different plate voltages. The chart below indicates the proper values of resistance for different plate voltages. The resistor values are chosen to allow the proper size for any usable plate voltage. To adjust the values of resistance, jump the resistors as indicated.

6.11 Plate voltage	Resistance	Jump resistors #
500-600	56,000	none
450-500	51,000	R20
400-450	38,000	R18
400	33,000	R19 & R20
350-400	33,000	R19 & R20
300-350	23,000	R17 & R18

- 6.12 The power amplifier plate circuit is a shunt fed Pi network. A small capacitor C33 feeds a small amount of RF back to the grid circuit for neutralization. The components R13-L21 are parasitic suppressors. The capacitor C39 is the coupling element between the tube and the output network.
- 6.13 The plate current metering is accomplished in the cathode as previously explained, 6.1.
- 6.14 The output network is designed to work the plate of the tube into a 50-70 ohm load. This load was chosen due to the wide usage of this impedance. If other impedances are desired, an antenna tuner or balun coils should be used.

- 6.15 The plate tuning is done with a two gang condenser CV4-CV5. The section CV4 is a small capacitor and is used for tuning the 10-15-20 meter bands. Its small size allows a degree of band spread over these ranges.
- 6.16 The section CV-5 is switched in parallel with CV-4 by S7A on the 40-75 meter bands. When the transmitter is on the 75 meter band, it is possible to set the capacity of the plate condenser, near open, and get 40 meter output. This should be avoided at all times and care should be exercised to be sure the capacitor is on the high capacity dip, knob to the right. The other bands will not have this characteristic.
- 6.17 The inductance L23 is tapped for the different bands. The switch S8A picks the taps as needed. The switch S7A and S8A are on the same shaft and are controlled by a lever from the main wave band switch knob.
- 6.18 The course load control is a tap switch S9 with a series of six 250 MMFD capacitors. As the control is rotated to the right or Clockwise, the capacitors are dropped one at a time. Turning the control to the right increases the loading into the antenna or load. As these capacitors are shunted from the antenna connector to ground, larger capacitors may be installed external to the transmitter if lower impedances are desired; however, this cannot be carried too far because of the fixed value of L23. While this is not necessary with 50-70 ohm non-reactive loads, and not recommended, it is brought up because of some condition that may exist in the field.
- 6.19 The fine load control is a tap switch S10 with a series of four 25 MMFD one 50 and one 100 MMFD capacitors. As the control is rotated to the right the 4-25 units are dropped one at a time and then the 50 and 100 are dropped.
- 6.20 With the two load controls a wide range of capacities are available. With both controls full left, the maximum capacity is 1750 MMFD. With both controls full right, the capacity is zero, except for stray wiring capacity. With the coarse control over two steps, the capacity would be 1750 less to 250 units or 1250 MMFD.
- 7.0 The antenna relay is a double pole double throw unit. One set of contacts, switches the antenna to the receiver or the transmitter, and the other set of contacts switches B plus from the exciter to #3 pin on J7 for use of the B voltage on the receiver. When a Morrow MBR-5 receiver is used with the transmitter, the receiver power supply supplies the exciter B plus and the cables take care of these interconnections.

- 7.1 The relay coil is energized through the microphone push to talk switch by the battery, either 6 or 12 volts, when mobile. The 12 volt cables CB12R, CB12E, CBJ12 have the relay coil dropping resistor in the plug cap. When the AC power supply is used, a full wave bridge rectifier supplies 6 volts DC for the antenna relay coil as well as the high voltage relay mounted in the power supply.
- 7.2 When the transmitter is used for CW, a transmit-receive switch should be mounted by the key and connected to pins #4 & 5 on J7, or to pins #3 and shell on mike jack J1. This will close the relay when the switch is turned to the transmit position. See diagram under installation 3.4.
- 8.0 The antenna fitting is a standard 23-1R and the plug is a PL 259. The receiver antenna connector is a standard auto radio fitting.
- 9.0 The Morrow MB-560 transmitter has a dual purpose speech amplifier. It is designed for either standard audio band pass or for the new narrow channel restricted audio range.
- 9.1 Under the condition of the standard audio system, the high and low frequencies are passed for normal speech quality. The audio range is from 100 cycles to 10,000 cycles. A crystal or dynamic microphone is recommended for this service.
- 9.2 When the new Narrow channel system is used, several important changes take place in the audio system. A speech peak limiter suppresses all voice peaks above a fixed level. Because peaks in the voice frequencies use a large amount of the modulator power, contribute nothing to the intelligence, and hold the average modulation to a low level to keep it from over modulating on peaks, their elimination is a great step forward in the design of a modern transmitter. With the limiter in the circuit, it is impossible to over modulate the transmitter, when the modulation level is properly set.
- 9.3 A speech filter must be used after a limiter and the following stages must be free of distortion. The modulator tubes must be able to pass all levels without limiting. The MB-560 modulators are capable of twice the audio they are ever called upon to handle and the above requirement is conservatively met.
- 9.4 The speech filter is an elaborate LC network. The unit passes all frequencies from 300 to 2500 cycles plus or minus 1 1/2 DB. The output is down 40 DB below 200 and above 3100 cycles. The net result of the limiter and filter is a modulator that will not overmodulate the transmitter and passes a narrow range of audio frequencies that are ideal for communications work.

- 9.5 The audio system in the transmitter will meet the FCC specifications for commercial service. The side bands are held down to a minimum and the talk power is high. The audio quality is good communications quality and should not be expected to sound like a broadcast station.
- 9.6 A carbon microphone is recommended for the restricted speech amplifier, however a crystal or dynamic may be used.
- 9.7 To change from one system to the other, merely flip a switch under the modulator section and reset the modulation level control.

INSTALLATION

- 0.0 The installation of the MB-560 transmitter has been made as easy as possible. It is a companion unit for the MBR-5 receiver and when the two are used together special slide-in JIFFY MOUNTS make the job simple to install and easy to remove for use in the home.
- 0.1 The Morrow JIFFY MOUNTS are two slide bars, mounted on top of the the transmitter cabinet that slide into two receptacles mounted either under the mounting plate or the receiver. When the two units are used, it is suggested the receiver be mounted on top of the transmitter.
- 0.2 The mounting plate with the two receptacles should be fastened to the lower edge of the dash. The back of the plate should be connected to the fire wall as per the drawing 0.3. The plate should be solid because the transmitter and receiver are suspended below.

0.3 JIFFY MOUNT:

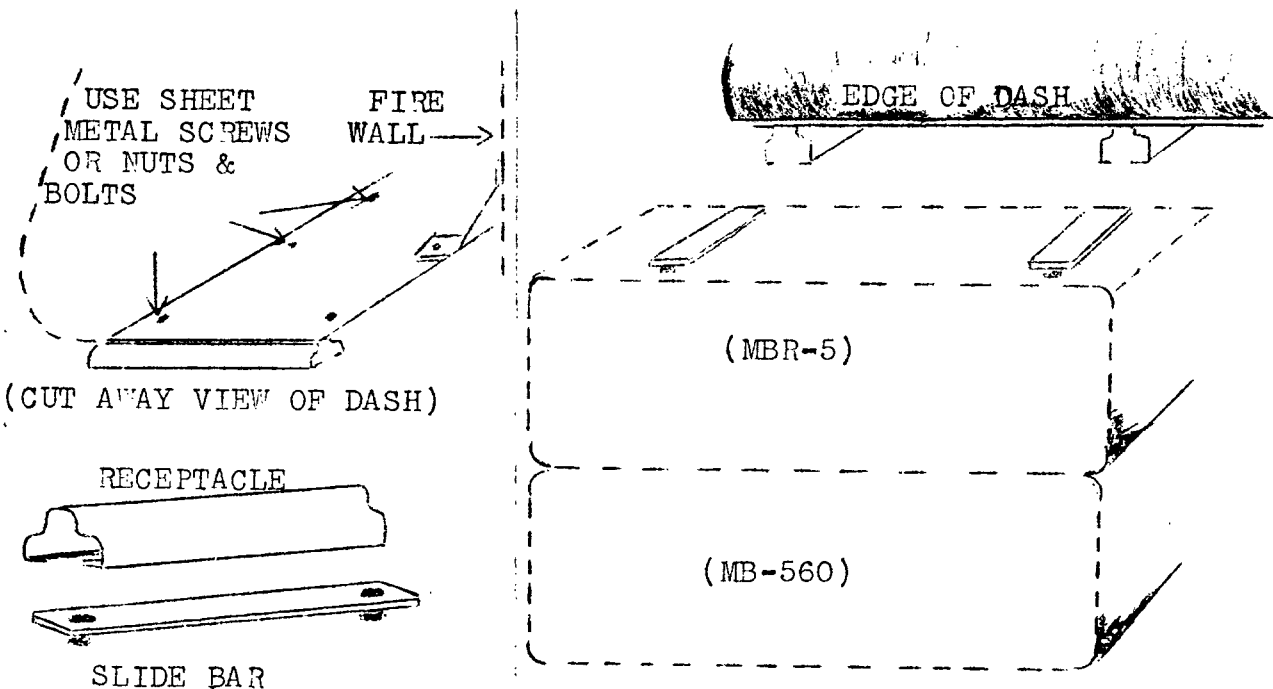

- 0.4 The exciter power supply, or receiver power supply when both are used, should be mounted on the fire wall inside the car. Be sure the supply is mounted so the cables can be left with some slack after they are plugged in.
- 0.5 The JIFFY MOUNTS are bolted to the cabinets with spacers holding the bar off the cabinet and the receptacles tight against the cabinet. Use the screws supplied and be sure there is a minimum of bolt protruding beyond the nut inside the cabinet.
- 0.6 When the transmitter is used in the home the JIFFY MOUNTS need not be removed. When the receiver is also used in the home, the two units may be connected together with the jiffy mounts and they both slide under the power supply speaker assembly (Model RTS-600S) making a complete home station and one that is small enough for portable work.

1.0 Microphone (Crystal)

A crystal or dynamic microphone is recommended when the wide pass-band audio system is used. The microphone should be on a push-to-talk stand or a push-to-talk switch should be mounted in a convenient location.

- 1.1 The microphone cable should be shielded and if the push-to-talk switch is included in the microphone stand, a separate pair should be run for it. The shield wire and the pair may be in one cable; however, the wires to these two units should not use a common conductor. See diagram 1.2.

1.2

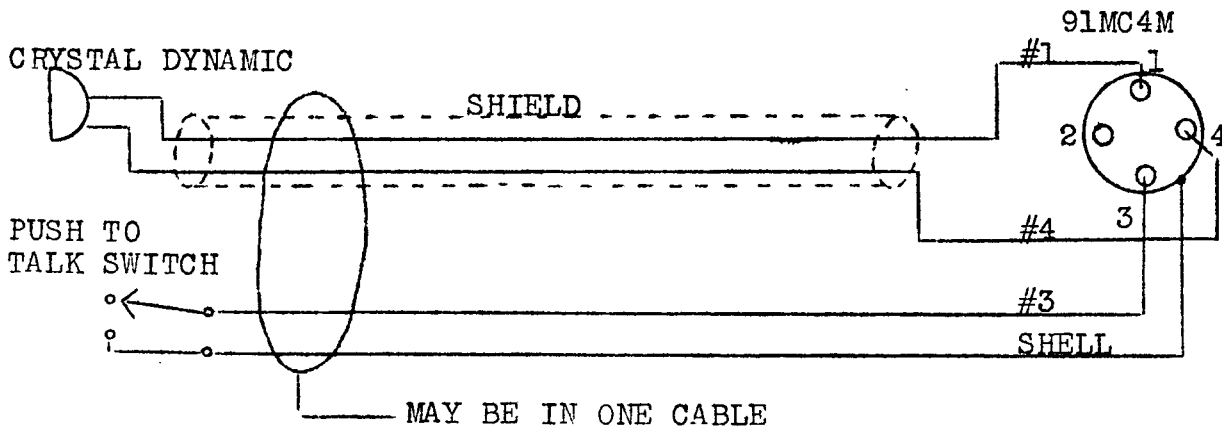

NOTE: Do not use #4 pin for ground for push to talk switch

2.0 Microphone (Carbon)

For restricted range audio or mobile operation, a carbon microphone is recommended. For restricted range audio, the frequency range is within limits of the microphone and no advantage will be gained in the use of a crystal unit. For mobile operation, a crystal microphone is definitely not recommended because of the heat problem and unit damage.

2.1 With a carbon microphone the mike cord may or may not be shielded. In any case, separate pairs should be run for the microphone unit and the push-to-talk switch. See diagram 3.2.

2.2 The element may be a Western Electric F1 or N1 or equivalent.

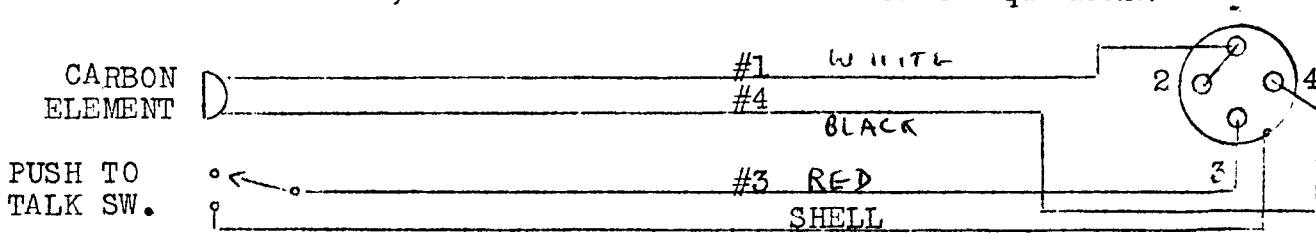

3.0 Key.

The key should be connected to a standard earphone plug through a key click filter as shown in 3.2.

3.1 A receive-transmit switch should be connected to pins #4 and #5 on jack J7. These connections can be made by removing the cap on the cable. The switch may be mounted on the key base or any convenient location. Some operators like a foot switch mounted under the operating table.

3.2

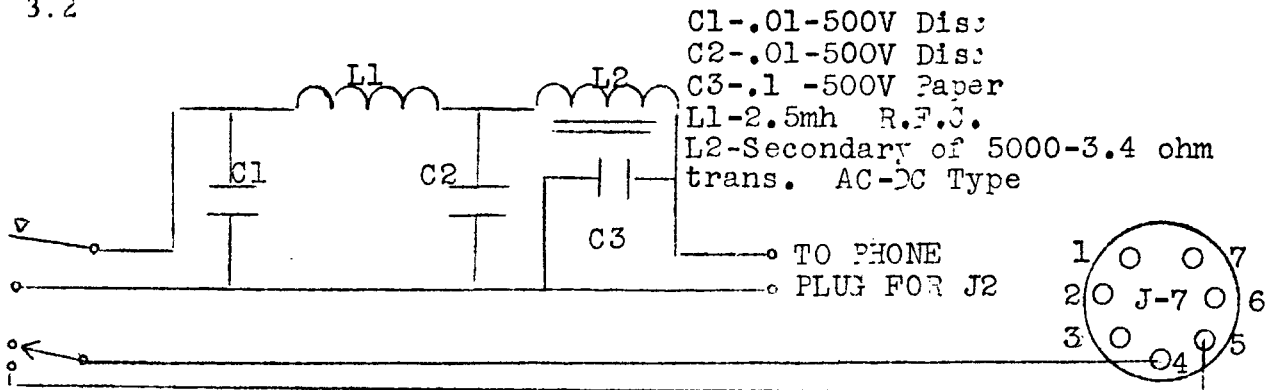

4.0 Power supply requirements.

The MB-560 is designed to be used with an external power supply. The external power supply may operate on 6 or 12 volts DC or 115 volts, 60 cycles AC.

4.1 The following paragraphs will describe the use of the MB-560 with a 6 or 12 volt power source. The 115V, 60 cycle operation will be covered in later pages.

4.2 Power supply voltages needed.

1. 6 volts DC at 6 amp or 12 volts DC at 3 amp is needed to heat the filaments.

2. 6 volts DC at 500 ma or 12 volts at 500 ma is needed to operate the relays. The relay in the transmitter requires 6 volts at 250 ma, and the external relay that controls the dynamotor solenoid, and opens B plus, makes up the additional power required.

3. 67.5 volts DC at 1 mill or less is needed to supply bias to the final amplifier and modulators. While the current drain is very small, the voltage should be well regulated such as by a battery. Burgess XX45 or Eveready 467.

4. 250 volts DC at 90 to 100 MA is needed for the exciter. This power may be taken from the receiver power supply. When the transmitter is used with a Morrow MBR-5, the power cable plugs into a socket on the power supply which makes this connection without change except for the removal of a jumper in the receiver power supply socket, from pin 2 to 3. This jumper is in the B plus circuit and when it is removed, it allows the power to go to the transmitter antenna change-over relay for switching from the receiver to the transmitter.

In case the receiver is not used, any 250 volt 100 ma power supply may be used. It is important that 250 volts be applied to the transmitter, because if the voltage is low, the drive on 10 meters may be down. The section dealing with the power supply cables gives information required for connecting to any power supply.

5. The high voltage power supply should have 400 to 600 volts available for the power amplifier and modulator. The current requirements are such as to need approximately 200 ma of current available. The final will draw about 116 ma and the modulator resting current is 40 ma, making a total of approximately 160 ma. The modulator peaks run this up to about 200 ma.

Either a dynamotor or a vibrator power supply may be used for this supply. It will be noted on the diagrams following, that a relay is used to control the dynamotor relay and to cut the high voltage when the push-to-talk button is released. Most dynamotor relays require too much current for the push-to-talk switch contacts and the control relay is required. The B plus set of contacts stop the dynamotor while in the receiver while the motor is coasting to a stop.

4.3 Power plug pins, and where they go.

While this information is on the diagram the following should be of some help in understanding the reason for the connections as they are.

J6 8 pin plug.

#1-----B minus or ground for high voltage source.

#2-----B plus from high voltage source.

#3-----Relay power source.

#4-----Ground for connecting filaments in series or parallel.

#5-----Relay control for dynamotor control relay or high voltage relay for AC operated unit.

- #6-----Center of series filament string. To power source on 6 volt application. Open on 12 volts.
- #7-----High side of filament string to power source on 12 volts. Ground on 6 volts.
- #8-----6 or 12 volt power connection for DC operation. Not used on 115 volt 60 cycles.

J7 7 pin plug.

- #1-----DC power input on 6 or 12 volts. One side of main off-on switch on DC or AC.
- #2-----B plus input for 250 volt supply.
- #3-----B plus output to receiver.
- #4-----Push-to-talk circuit. Ground to close relays.
- #5-----Ground or B minus for 250 volt B supply, relay ground for CW transmit switch, ground for relay power on AC supply, ground or plus side of bias battery.
- #6-----Bias minus input 67.5 volts.
- #7-----Main off-on switch return.

5.0 Power supply connections, MOBILE:

The MB-560 transmitter is designed to operate on 6 volts DC, 12 volts DC, and 115 volt, 60 cycles AC. The Morrow MBR-5 receiver is a companion unit and when the two are used together the receiver power supply also supplies power to the transmitter exciter.

5.1 Morrow MB-560 transmitter and MBR-5 receiver, 6 or 12 volts:

When these two units are used together two power supply cables are used. Cable #CBF7-235X156 connects the transmitter to the receiver power supply for either 6 or 12 volt operation. Cable CBF8-125X368-47 connects the transmitter to the high voltage supply and connects the filaments for 6 volt operation. Cable CBF8-125X3R78 connects the transmitter to the high voltage power supply and connects the filaments for 12 volt operation.

5.2 These cables are available in pairs and should be ordered under the group number:

- 6 Volt operation: Cable kit #CB6R includes 1..CBF7-235X156
1..CBF8-125X368-47
- 12 Volt operation: Cable kit #CB12R includes 1..CBF7-235X156
1..CBF8-125X3R78

5.3 Cable diagram.

It will be noted the high voltage cables differ only in the jumpers on the plug and the addition of a resistor to cut the 12 volts to 6 for the relay on the 12 volt unit. All wires in all cables follow the color code; ie, brown is #1, red is #2, orange is #3 etc.

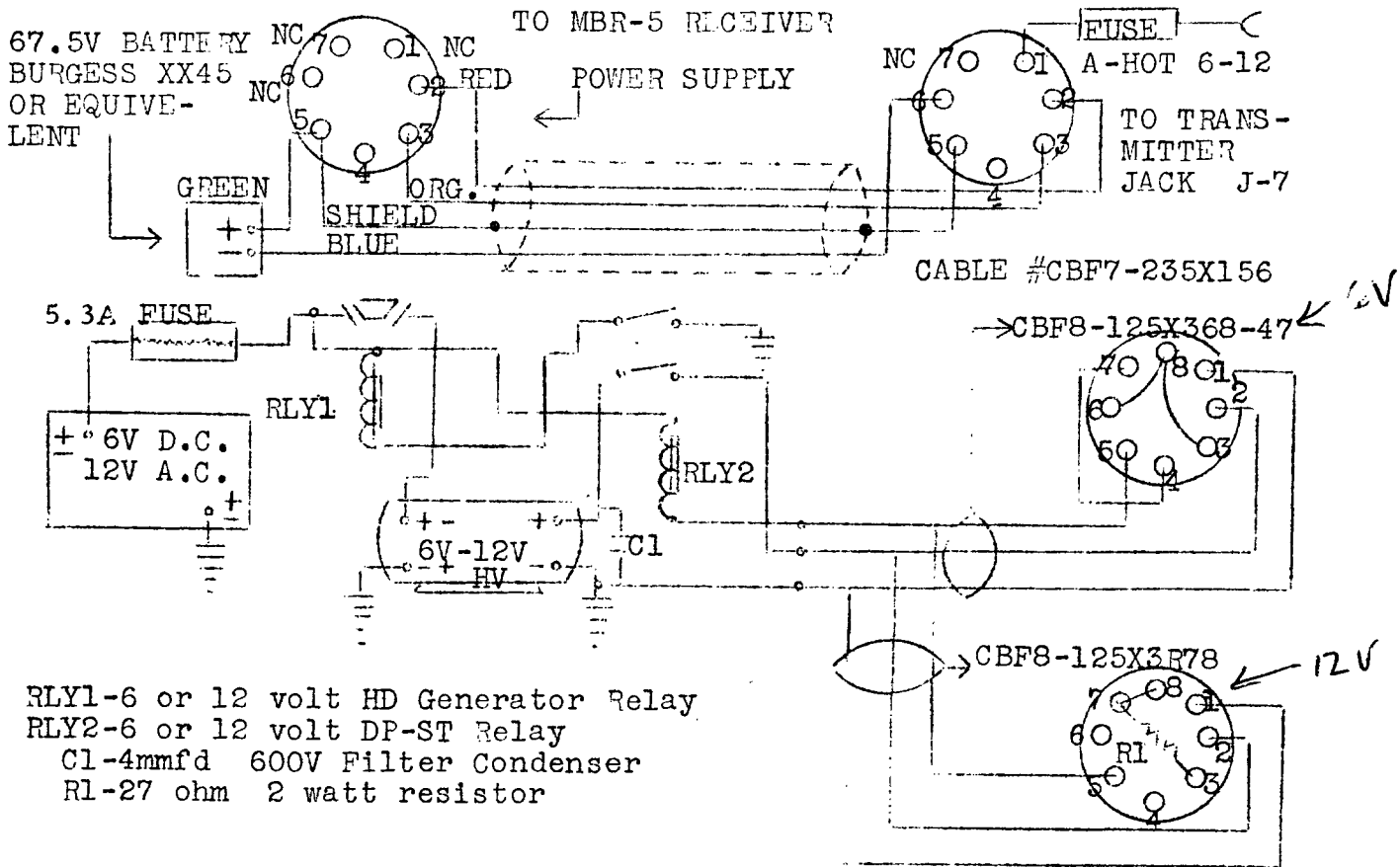

5.4 The bias battery is a 67.5 volt unit and should be mounted close to the exciter power supply. The green wire is positive and the blue wire is negative. These wires come out of the 7 wire cable at the power supply end.

5.5 Control function.

The receiver must be turned on to operate the transmitter because the receiver controls the exciter power supply. The transmitter Cff-Cn switch controls the filament on the transmitter.

6.0 Cable connections when the exciter has a separate power supply.

The power supply recommended is the model RVP-250, a 250 volt vibrator power supply. See Diagram 6.5.

6.1 If a power supply other than the above is used, follow the diagram 6.6.

6.2 Two power supply cables are needed, a 7 pin cable for the low voltage supply, and an 8 pin cable for the high voltage supply. Order cables in sets as in 6.4.

6.3 Low voltage cable for 6 or 12 volt..... CBF7-1245X56
 High voltage cable 6 volts CBF8-125X368-47
 High voltage cable 12 volts..... CBF8-125X3R78

6.4 Order cable sets as follows:

CB6E for 6 volts includes 1 ea.CBF7-1245X56
 1 ea.CBF8-125X368-47
 CB12E for 12 volts includes 1 ea.CBF7-1245X56
 1 ea.CBF8-125X3R78

6.5 Cable diagram. For use where exciter power supply is RVP-250.
 #CBF7-1245X56

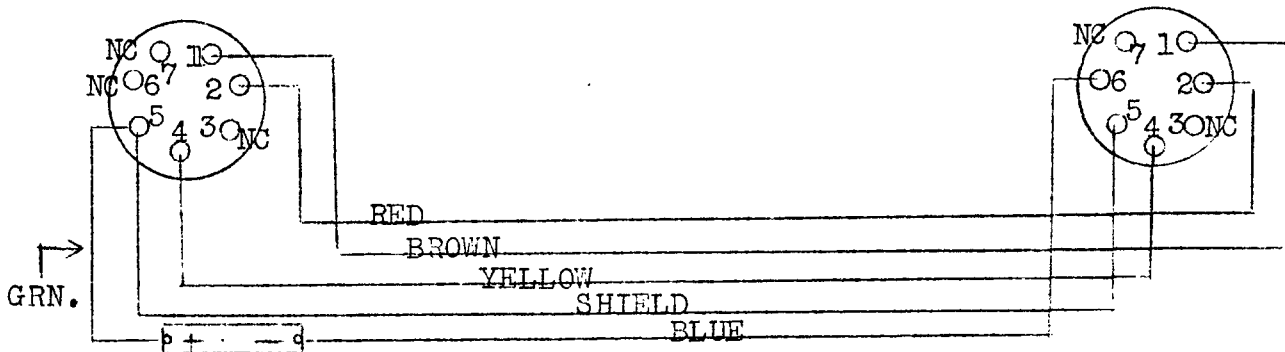

67.5
 Use high voltage cables as in 5.3A

6.6 Cable diagram for use where exciter power supply is other than Morrow RVP-250.

Use cable CBF7-1245X56 as in 6.5 with extension as shown.

Use high voltage cables as in 5.3A

Extension for CBF7-1245X56

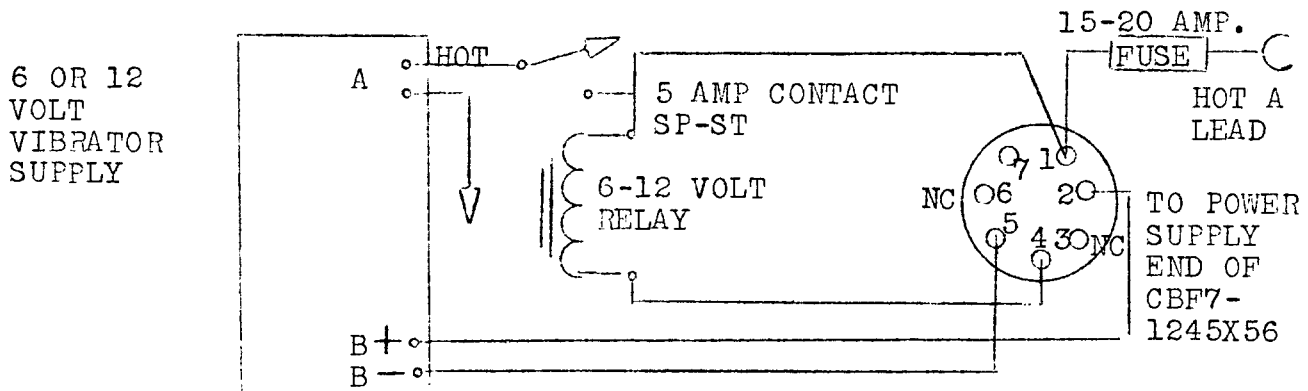

6.7 The bias battery is connected to the wires extending from the cable #CB F7-1245X56. Burgess XX45 or Eveready 467. Blue wire negative, green wire positive.

6.8 Control functions are normal, ie; transmitter control switch operates all power supplies.

7.0 Using James power supply Model C1050 for High Voltage supply.

The James power supply may be used for high voltage supply in place of a dynamotor. It cannot be used to supply the exciter because of excessive current drain and insufficient regulation of the low voltage tap.

7.1 If the Morrow MBR-5 receiver is used with the MB-560 transmitter and a James supply is used for the high voltage, the exciter power cable is #35X156. See diagram 5.3

7.2 If the Morrow MBR-5 receiver is not used, we suggest the exciter power supply be a Morrow RVP-250. In this case, use exciter power cable #CBF7-1245X56, diagram 6.5. It just plugs in the power supply and no cable work is needed.

7.2 If neither the Morrow receiver or power supply is used, see paragraph 6.6. Use cable CBF7-1245X56 and make a termination box as shown in 6.6.

7.3 The cables to the James power supply for high voltage connections are: 6 volt, #CBF8-2X18 and 12 volt, #CBF8-2X20. See 7.4 and 7.5 for cable diagram.

Cable CBF8-2X18

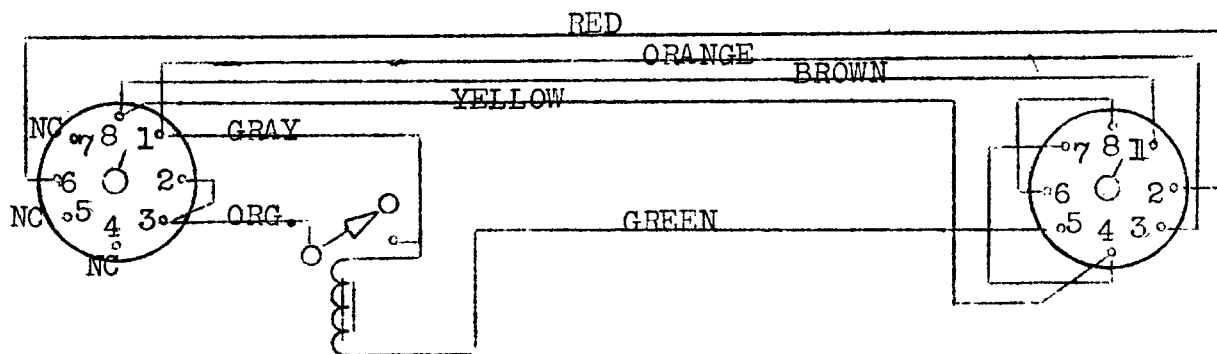

Cable CBF8-2X20

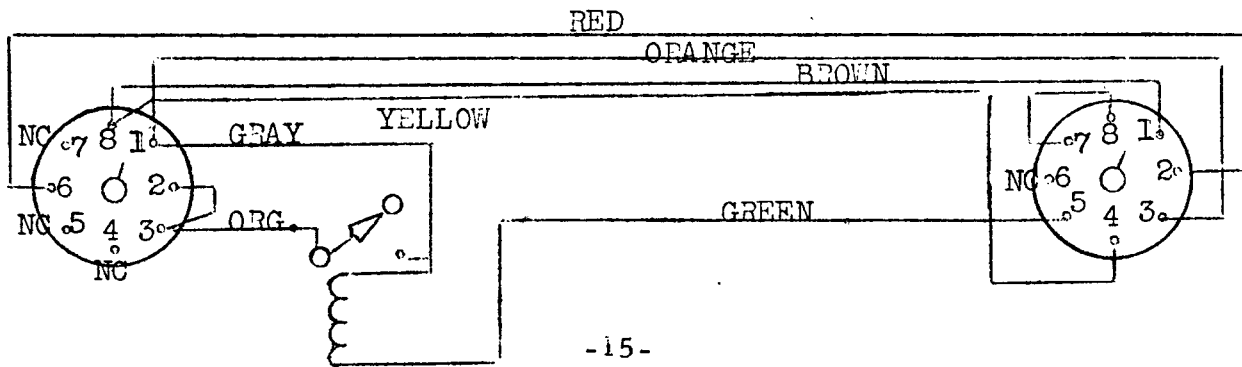

8.0 The AC power supplies

A combination AC power supply, Model #RTS-600S, is available for operating the MB-560 transmitter and MBR-5 receiver. This unit is complete with speaker and all relays, controls etc. It mounts either on top or behind the transmitter-receiver. A stacking frame combines the units into a complete station for desk mounting or portable work. Note: Jump pins 4 to 7 on J2 if the receiver is not used.

8.1 The transmitter may also be used with power supply model TS-600 supplying voltage for the transmitter only. This supply is complete with relay power and all control functions.

8.2 In cases where power supplies other than the special units are used, the requirements are as follows:

8.3 Filament power: 6 volts AC at 6 amperes, or 12 volts AC at 3 amperes.

8.4 Relay power: 6 volts DC at 500 ma. To obtain this voltage use an AC source of 9 volts and bridge rectify it. See diagram of TS-600 or RTS-600S supply. A 6 volt battery may also be used.

8.5 Bias voltage 67.5 volts: AN AC voltage of 95 volts may be rectified with a half wave selenium rectifier and filtered with an RC filter followed by a VR 75 regulator as per the diagram for the TS-600 supply. The additional voltage 75-67.5 is of no importance because the modulator bias adjustment will compensate for the difference. Do not use a VR90 because it will be too far out of limits. A battery may also be used in place of the supply.

8.6 250 volts DC: This supply may be any supply that will give 250 volts at 100 ma. The upper limit of voltage should not exceed 275 volts.

8.7 High voltage supply: A 400-600 volt supply with a current capability of 200 ma may be used for the high voltage supply.

8.8 Both the 250 and the 600 volt supply should be switched off when the receiver is used and the transmitter is off or during stand by periods.

8.9 For AC power supply connections to the transmitter, see paragraphs 4.2 - 4.3 and diagram of RTS-600S or TS-600 power supply.

The AC power supply requires two cables. The 7 pin cable is #CBF7-123567 and the 8 pin cable is #CBF8-123457.

On the seven pin cable wires run from socket to plug on pins #1-1, 2-2, 3-3, 5-5, 6-6, 7-7. #4 contact is open. On 8 pin cables wires run from pins 1-1, 2-2, 3-3, 4-4, 5-5, 7--7, with pins #6 and 8 open.

Operating Instructions

- 0.0 The regulations of the Federal Communications Commission, require a suitable license for the operation of this equipment. Refer to publications of the FCC or the American Radio Relay League for the latest rules governing station and operator's licensing.
- 0.1 Standard operating procedure for amateur radio stations is covered in the ARRL publications and should be reviewed to assure one of the best operating techniques.
- 1.0 CW operation: Insert key in proper jack and set CW-Phone switch in CW position. Omit steps marked with an *.
- 1.1 Phone operation: Place Phone-CW switch in phone position (toward center of case). Connect microphone, and use all the following steps:
 - 2.0 Set operate switch in tune position.
 - 2.1 Turn wave band switch to proper band, ie, 75-40-20-15-10 meters.
 - 2.2 V.F.O. Set VFO-XTAL switch in VFO position.
Adjust dial to frequency, or
Zero beat to received signal by turning operate switch to ZB position and adjusting the dial to zero beat with the received signal. Return operate switch to tune position.
 - 2.3 Crystal control: Set V.F.O. Xtal switch in XTAL position. Insert crystal in crystal socket.
Set dial to operating frequency, ie, operation desired on 29.0 MC, insert 7250 KC crystal and set dial to 29.0 MC.
 - 2.4 Place meter switch in GRID position.
 - 2.5 Set COURSE LOAD and FINE LOAD controls in extreme counter-clockwise position (minimum loading).
 - 2.6 Press push-to-talk switch on microphone or turn receive-transmit switch to transmit position for CW. Transmit switch, see page 10, paragraph 3.1-3.2.
 - 2.7 Adjust drive control for 3.0 MA.. When using crystal control, rock dial across frequency for maximum drive.

- 2.8 Set meter in PLT position, and dip PA TUNE for minimum plate current. Note: on 75 meters use the dip with maximum capacity or clockwise. It is possible on 75 meter position to double to 40 with the minimum capacity setting and this should be avoided at all times.
- 2.9 Set operate switch on OPR position.
- 3.0 Turn COURSE LOAD to the right to increase antenna loading. Be sure PA TUNE is always on the dip. Increase loading until the plate current is 110-120 ma, with PA TUNE adjusted for dip or minimum current.
- It will be found that one setting of the course loading control will give a reading under 110 ma and the next setting will be above 120 ma. Reset the control to the lower reading and increase loading with the fine load control, to a point between 110 and 120 ma.
- The capacity range of the fine load control is such as to fill the gaps in the course load and acts as a vernier control. The two switches give 49 possible loading conditions.
- 3.1 Check PA TUNE for dip and set GRID for 3 MA.
- *4.0 Turn METER switch to MOD and with no audio input, adjust R46 modulator bias control for a meter reading of 40 MA. R46 is located on the back panel under the 8 pin plug J6 toward the center of the case. This adjustment need be made only once when the transmitter is first installed and should need no further attention. In case the control will not return the plate current to 40 MA, the 67.5 volt bias battery should be replaced. The bias is obtained from a bias supply in the AC power supply for fixed station use.
- *4.1 See section 9.0 - 9.7 on page #7.
- *4.2 The Modulation control R38, located on the back panel under the mike jack, toward the side of the case, need be set once and should not be tampered with.
- Because the modulation limiter holds all signals constant at the input to this control, if it is once set for 100% modulation, all input levels will be held to the setting.
- *4.3 The only correct way to set any modulation control is to use an oscilloscope and observe the pattern.
- The trapezoid pattern is the better method but rather inconvenient because of the connections that need be made and for this reason we suggest the envelope method as follows:
- *4.4 Any oscilloscope may be used and with the gimmick as shown in 4.8 proceed as follows:

- *4.5 Tune C1 for maximum pattern on the tube face. The scope should be easy to observe and the pickup wire should be near to the antenna to allow enough RF to be observed on the tube face.
- *4.6 Feed a constant tone in the mike and set the control R38 for 100% modulation. We suggest you read further in the ARRL handbook for more information if needed.
- *4.7 The modulator plate current will peak up to 70-80 MA when the transmitter is fully modulated.

*4.8

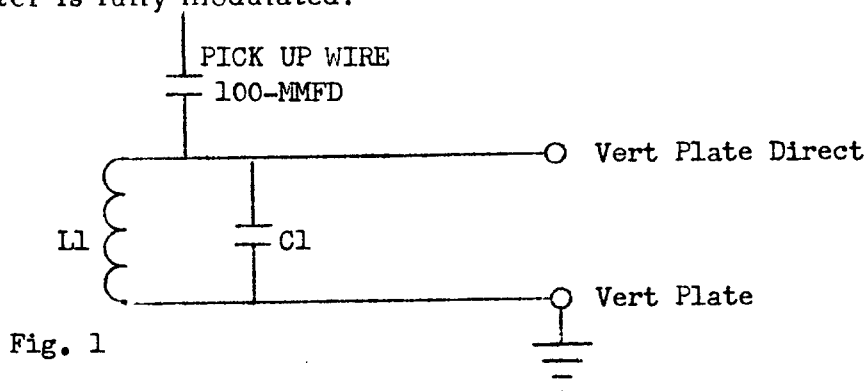

Fig. 1

Mobile Antennas

- 5.0 A mobile antenna should be considered as a quarter wave antenna that has been shortened with a loading coil, to bring its' height down to a reasonable value.
- 5.1 The loading coil may be at the bottom of the whip, the center or the top. The most reasonable position is either at the base or in the center. On the lower frequency bands the coil is the greater part of the antenna and its Q, or its' quality should be as high as possible. This calls for a coil of reasonable diameter and as large a wire as practical.
- 5.2 Several coils and whips are available and they all give reasonably good results, when they are properly tuned. It must be stated, however, that the tuning is a very important factor and if more than one frequency is to be used some method must be provided for tuning the antenna to the operating frequency.
- 5.3 In the early days of mobile radio, the transmitters were nearly all crystal controlled and a fixed tuned antenna was practical but with the new 5-band variable frequency transmitters, such an antenna limits the usefulness of the transmitter to a degree which is not desirable. An antenna tuned to a frequency, 3950KC for example, cannot be used much above 3960 or below 3940, without a great loss in radiated signal strength. An antenna with broad band characteristics in all probability is not tuned anywhere near the operating frequency and is in a sense not an antenna. An antenna that is tuned correctly will have a very

sharp resonance peak and will load only on the resonant frequency.

- 5.4 Tuning the antenna to a spot frequency is quite a problem because it is critical to within 1/4 turn. A much more practical antenna tuning system is to use a roller coil at the base of the antenna. The roller coil may be adjusted manually which is not very satisfactory when you are driving down the highway and changing frequency, or by the use of an electric motor controlled from the operating position.
- 5.5 The Morrow MLV-50 antenna tuner, is a roller coil, electrically actuated by a motor, controlled from the operating position. The MLV-50 incorporates a line to antenna impedance matching network allowing the pi network to work into its' characteristic impedance.
- 5.6 The MLV-50 has its' greatest value on 75-40 and 20 meters. It may also be used on 15 and 10 meters, however on 10 meters we recommend the antenna feed line connect directly to the base of the antenna. With a loading coil on the antenna cut for 4000 KC, the MLV-50 will tune the antenna from 4000 KC down to 3750KC. The 75 meter coil may be shorted and the MLV-50 will base load the antenna for 40 and 20 and 15 operation. On 40 meters better results will be had if the loading coil is cut for 7300 KC and the tuner is used for its prime purpose ie, to tune the antenna from 7300 down to 7000KC. On 20 and 15 meters, the MLV-50 can be used as a base load with results about equal to a center loaded antenna, with tuner.
- 5.6 The matching network on the MLV-50 is set for 75 meter operation because this is the frequency where the greatest mis-match occurs. A 75 meter antenna has an impedance below 15 ohms offering a loss when it is fed with a 50 ohm line. If the matching network is not used the feed line becomes part of the antenna, a very undesirable condition.
- 5.7 To adjust the loading coil on the antenna with an MLV-50 installed, we will use as an example, the 75 meter band. Connect the MLV-50 to the antenna and connect the coax feed line. Couple the transmitter end of the feed line to a grid dip meter by a 4-5 turn link, temporarily fastened to the end of the line. With the roller coil set for minimum inductance, roller on the end of the coil away from the motor, check antenna frequency by noticing the dip on the grid dip meter. Remove turns from the loading coil until the frequency is just above 4000 KC. Be sure the trunk lid is closed and the antenna is free of trees or other objects. Many turns will need to be removed. When the antenna is adjusted, connect the feed line to the transmitter.
- 5.8 Loading the transmitter. In every case the loading of the transmitter is a function of the antenna tuning. For example, 3900KC. Set the transmitter to 3900KC. Have the course and fine load controls to the left or counter clockwise. Dip the final for minimum plate

current. Turn on the MLV-50 motor and watch the plate current. When the antenna comes into resonance the plate current will increase. Keep the final dipped at all times. After the motor turns the MLV-50 through resonance, the current will drop. Back the motor up for a peak current reading with the final dipped. Increase coupling for a plate current of 110-120 ma with the final dipped.

- 5.9 If a Morrow MBR-5 receiver is used the indicator should be the FIELD STRENGTH meter. Always tune the antenna and the transmitter for maximum field strength reading.

Fixed Station Antennas

- 6.0 A pi network is designed to work into a low impedance such as 50 or 75 ohm coax. An antenna which has a characteristic impedance of 50 to 75 ohms is preferable for the MB-560 such as a dipole, ground plane or coax-fed beam. On 10, 15 or 20 meters, the beam type is recommended due to its' high gain and directional characteristics. On 40 and 75 meters, a dipole or ground plane is most satisfactory. All band antennas are generally a compromise in antenna design and are subject to harmonic radiation as well as the desired signal, Ideally, single band antennas are recommended.
- 6.1 When balanced feed lines are used such as 300 ohm twin lead, some matching device is necessary to couple into the pi network. Balun coils which are available commercially (or instructions for winding them can be found in the ARRL handbook) will match the unbalanced output of a pi network to a balanced feed line quite satisfactorily. If a balanced feed line is used without some matching device, a standing wave ratio and impedance mis-match will be so great that most of the signal will be dissipated in the form of ineffectual energy.
- 6.2 In all cases an adequate ground must be used. Four to eight feet of copper rod can be driven into the ground and a number 10 or heavier copper ground wire attached and run to the chassis of the MB-560. This will generally be adequate, providing the ground wire is not too long. If there is any evidence of RF on the transmitter cabinet such as manifested by touching the knobs on the cabinet and feeling a bite or by lighting a small neon bulb when touching the cabinet when the transmitter is turned on, it is an indication of an inadequate ground or a mis-match to the antenna system or both.
- 6.3 Satisfying results can be achieved with the MB-560 by use of an adequate antenna installation. For further details on antennas, we recommend the ARRL handbook or the ARRL antenna handbook.

MB-560 Parts List

R1	47K	C1	5-25NPO plus 14 N1400
R2	47K	C2	5-25NPO plus 50 N330 33 N750
R3	2200	C3	5-25NPO plus 50 N330 100 N470
R4	47K	C4	5-25NPO plus 50 N330 100 N470
R5	22K	C5	5-25NPO plus 50 N470
R6	180	C6	250SM
R7	47K	C7	250SM
R8	1500 10W	C8	100SM
R9	220	C9	10SM
R10	5600	C10	.01 Disc. 500 volt
R11	4.7 1W	C11	50 N330
R12	4.7 1W	C12	50 N330
R13	100 1W	C13	.01 disc. 500 volt
R14	100K 1W	C14	Omit
R15	4.7 1W	C15	Omit
R16	47	C16	Omit
R17	15K 2W	C17	.01 disc. 500 volt
R18	18K 2W	C18	.01 disc. 500 volt
R19	18K 2W	C19	50 N330
R20	4700 1W	C20	50 N330
R21	56K 1W	C21	33 N330
R22	Omit	C22	Omit
R23	100K Pot.	C23	50 N330
R24	2000 ohm reostat	C24	.01 disc. 500 volt
R25	68 68 parallel	C25	.01 disc. 500 volt
R26	Omit	C26	.01 disc. 500 volt
R27	Omit	C27	.002 disc. 500 volt
R28	10 meg	C28	2000 SM
R29	220K	C29	2000 SM
R30	100K	C30	250 SM plus 50-500 mica trimmer
R31	2200	C31	50-500 mica trimmer
R32	2200	C32	50-500 mica trimmer
R33	180K 1W	C33	6 mmfd 2000 volt
R34	180K	C34	.01 disc. 500 volt
R35	2200	C35	.01 disc. 500 volt
R36	180	C36	.01 disc. 500 volt
R37	470	C37	.002 disc. 500 volt
R38	500K Pot.	C38	.005 disc. 1600 volt
R39	2200	C39	.001 disc. 2000 volt
R40	220K	C40	50 N330
R41	220K	C41	50 N330
R43	10K	C42	50 N330
R44	220K	C43	250 SM
R45	4.7 1W	C44	250 SM
R46	20K Pot.	C45	250 SM
R47	470K	C46	250 SM
R48	180K	C47	250 SM
R49	22K	C48	250 SM

C49 24 SM
 C50 24 SM
 C51 24 SM
 C52 24 SM
 C53 50 SM
 C54 100 SM
 C55 .01 disc 500 volt
 C56 .01 disc 500 volt
 C57 .001 disc 500 volt
 C58 .01 disc 500 volt
 C59 15 MF 25 volt
 C60 .002 disc 500 volt
 C61 15 MF 25 volt
 C62 .01 disc 500 volt
 C63 15 MF 25 volt
 C64 .01 disc 500 vclt
 C65 .01 disc 500 vclt
 C66 .01 disc 500 volt
 C67 100 tubular 500 volt
 C68 100 tubular 500 volt
 C69 .1 MF tubular 500 vclt
 C70 .1 MF tubular 500 volt
 C71 .01 disc 500 volt
 L1 75 meter osc coil
 L2 40 meter osc coil
 L3 20 meter osc coil
 L4 15 meter osc coil
 L5 10 meter osc coil
 L6 460 uh RF choke
 L7 460 uh RF choke
 L8 omit
 L9 460 uh RF chcke
 L10 40 meter amp coil
 L11 20 meter amp coil
 L12 15 meter amp coil
 L13 10 meter amp coil
 L14 2.5 mh RF choke
 L15 75 meter drive ocil
 L16 40 meter drive coil
 L17 20 meter drive coil
 L18 15 meter drive coil
 L19 10 meter drive coil
 L20 460 uh RF choke
 L21 Parasitic choke
 L22 2.5 mh RF choke
 L23 5 band tank coil
 CV1-2-3 VFO tuning condenser
 CV-4-5 PA tuning condenser
 CV Oscillator trimmer

Part # CF1077
 CF1078
 CF1079
 CF1080
 CF1081
 C1032
 C1032
 C1032
 CF1022
 CF1082
 CF1083
 CF1084
 C1001-1
 CF1085
 CF1086
 CF1087
 CF1088
 CF1089
 C1032
 CF1091
 C1092
 CF1090
 TC-1-1
 TC-1-2
 A14-30

T1	Modulation transformer	Part # A38-14C
BPF	Band Pass Filter	MMRT-W5
MA	0-1 ma	A37-4-2
N1	Western electric N1 unit	A44-6
SM1	Push to talk switch	A36-50-1
P1	Microphone plug #91 MC4M	A22-12
J1	Microphone socket 91 PC4F	A22-10
J2	Key jack	A22-45
J3	Crystal socket .486 - .093	A21-11-1
J4	Receiver antenna socket	A21-12
J5	Antenna socket #83-1R	A22-18
J6	Power plug 8 pin	A22-7-4
	Matching unit #78-PF8-11	A21-17-2
	and	A22-28
J7	Power plug 7 pin	A22-7-3
	Matching unit #78-PF7S-11	A21-17-3
	and	A22-28
RLY1	Relay DPDT 6VDC 26 ohm	A55-20
S1A	Shorting wafer	A36-31
S2A	Shorting wafer	A36-31
S3A	2P5P wafer	A36-30
S4A	Shorting wafer	A36-31
S5A	2P5P wafer	A36-30
S5B	Part of S5A	
S6A	Shorting wafer	A36-31
S7A	Ceramic wafer	A36-54
S8A	Ceramic wafer	A36-54
S9	Course load switch	A36-52
S10	Fine load switch	A36-52
S11	VFC Xtal switch	A36-51-1
S12	Meter switch	A36-55
S13	Phone CW switch	A36-35
S14	Operate switch	A36-53
S15	Filter switch	A36-35
	Dial glass	A80-1
	Band switch knob	FBR-26
	Tuning knob	FBR-23
	Control knob	FTR-A18
	Small knob	FBR-25
	Knob shaft and gear	MB-560-A2
	Pinion gear	MB-560-A3
	Large drive gear	MB-560-A1
	Wave band switch shaft S1A-S6A	A36-41-1
	Wave band switch shaft S7a-S8A	A36-42
	Wave band switch arm	MB-560-A13
	Wave band switch tie rod	MB-560-16

MB-560 Voltage Chart

Wave band switch on 75 and dial set at 3.9MC
 RMS* R.F. Measured with Hewlett Packard VTVM 410-B
 *VTVM-DC

- | | | |
|---------------------------|-------------------------------|-----------------------------|
| 1. Power supply - AC-115V | 5. S2A - In 75 meter position | 8. S-13-Phone position |
| 2. S14 - In OPR position | 6. S12- In grid position | 9. Modulator IP40MA |
| 3. S11 - In VFO position | 7. 6146 Loaded to 120 MA | 10. No-audio input |
| 4. S11 - In XTAL position | Into dummy 52 ohm load | 11. Make connected(N-1) |
| | | 12. Push-to-talk switch on. |

Tube	1	2	3	4	5	6	7	8	9
OSC	218V	RMS 13V	RMS 8V	AC 5.6V	0				
12AT7	218V	RMS 13V	RMS 8V	AC 5.6V	0				
6AV5	218V	RMS 7½V	13V	0	AC 5.6V	262V	165V	RMS 4½V	1.8V
Doubler	262V	262V	0	0	AC 5.6V	32V	0	-5V RMS	NC
5753	262V	262V	0	0	AC 5.6V	32V	0	RMS 10V	NC
Final 6146	0	AC 5.6V	175V	0	-7.5DCV 60VRMS	0	0	0	
Top of R-20	540V								
1st. AF 12AX7	* 95V	NR	0	AC 5.6V	AC 5.6V	* 218V	NR	* 1.9V	AC 11.2V
Clipper 6AL5	* 5. V	0	AC 5.6V	0	* 2.5V	* 2.5	* 2.5		
Driver 12AT7	* 110V	NR	* 2.2V	AC 5.6V	AC 5.6V	* 105V	NR	* 2.2V	AC 11.2V
Modultr 6AV5	* -52V	AC 11.2V	0	NC	DC 550V	NC	AC 5.6	218V	
Modultr 6AV5	* -52V	AC 11.2V	0	NC	DC 550V	NC	AC 5.6	218V	
V-R Back OB2	218V	108V	NC	108V	NC	NC	NC		
V-R Front OB2	108V	0	NC	NC	NC	NC	NC		
J1	* .2V	* .2V	0	0					
J6	0	DC 560V	DC 8.5V	0	0	AC 5.6V	AC 11.2V		
J7		DC 262V	0	0	0	DC -75			

RMS across Antenna 44 volts

MORROW MB-560 TRANSMITTER
BLOCK DIAGRAM

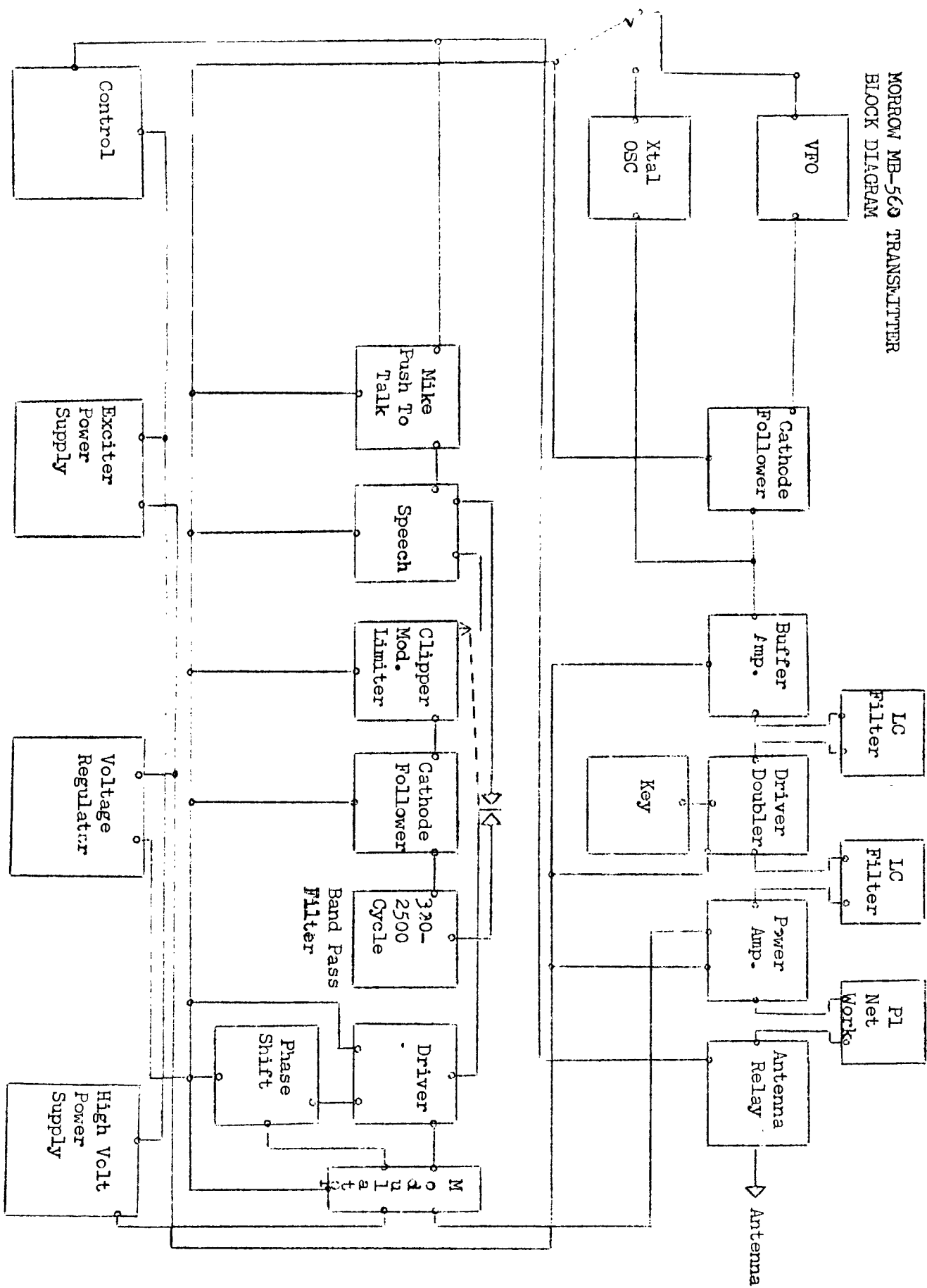

BOTTOM VIEW MS-560 TRANSMITTER

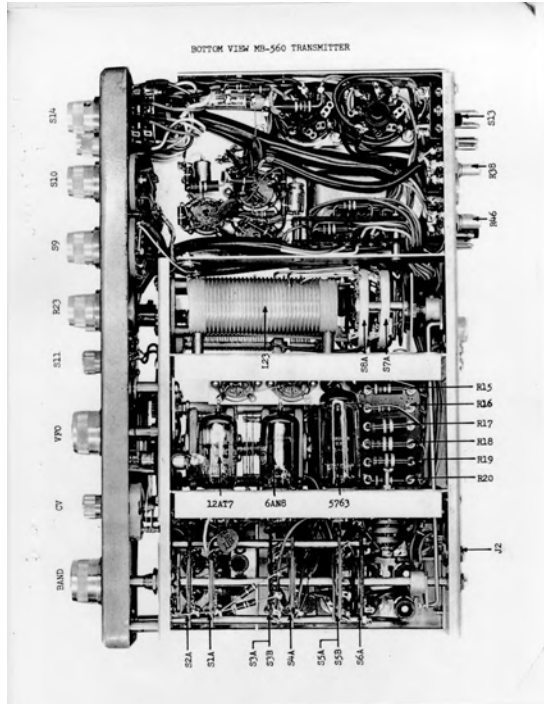

TOP VIEW MB-560 TRANSMITTER

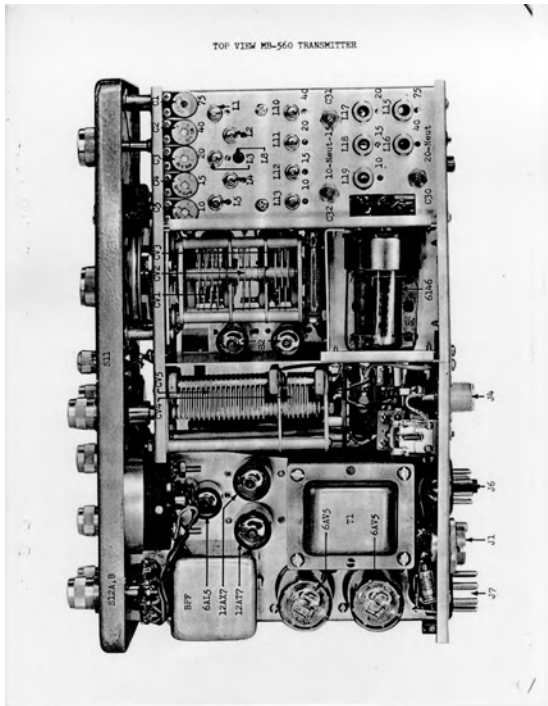

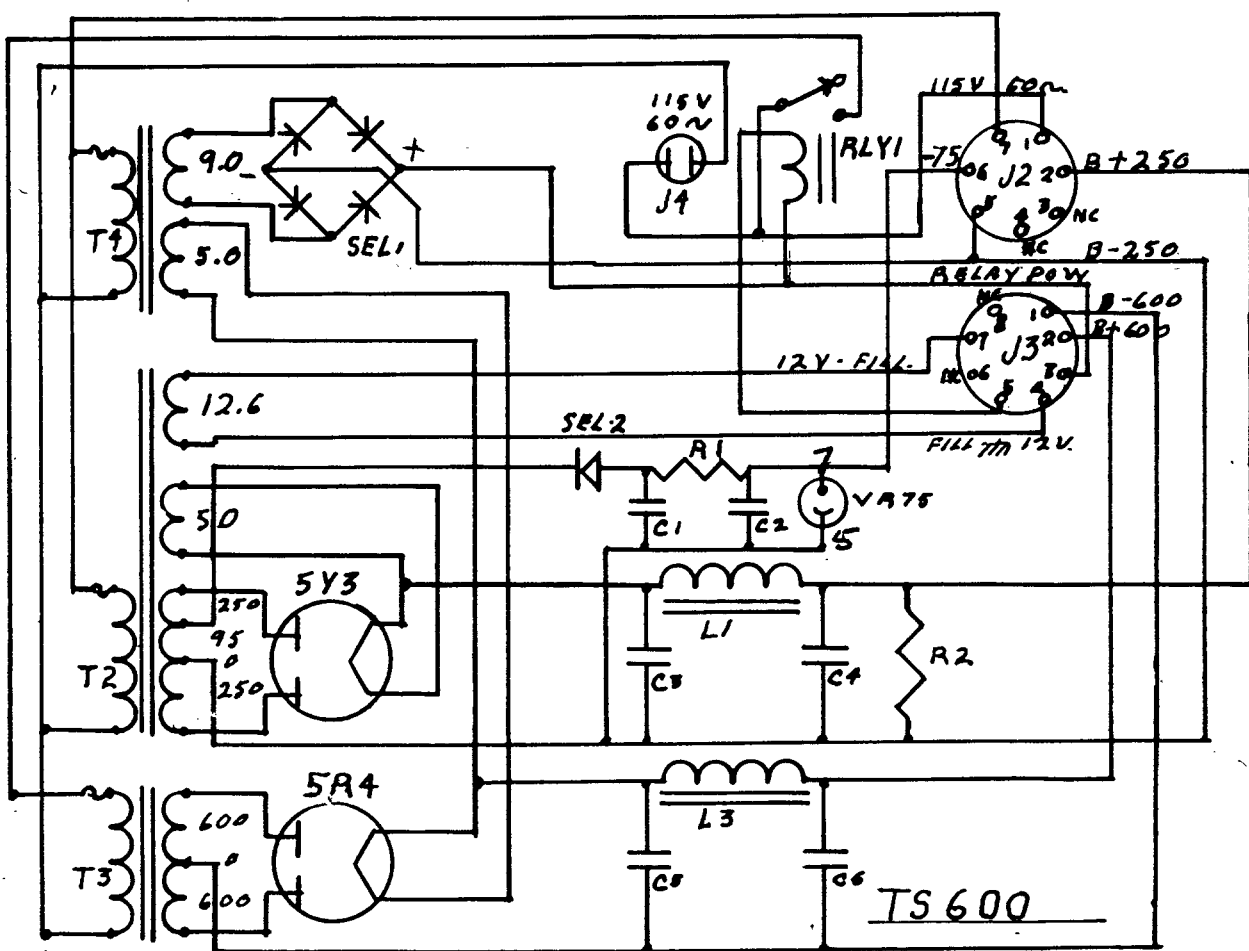
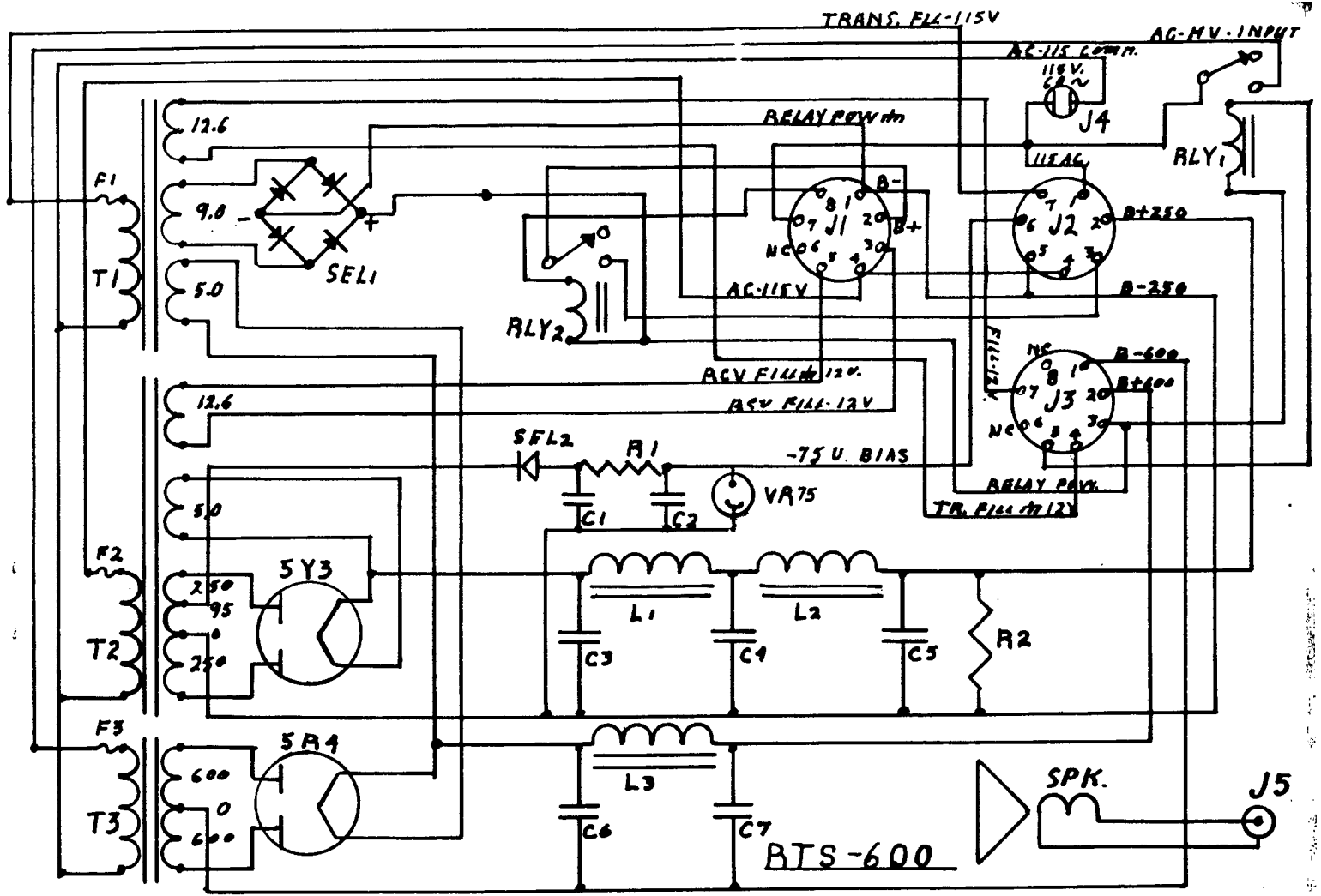

POWER SUPPLIES FOR THE MB-560
Manufactured by MORROW Radio Mfg. Co.

CHANGES TO SCHEMATIC DIAGRAM

Circuit changer

5763 - Drive control

Omit: R21-22 in 5763 screen circuit

Circuit changed to one below

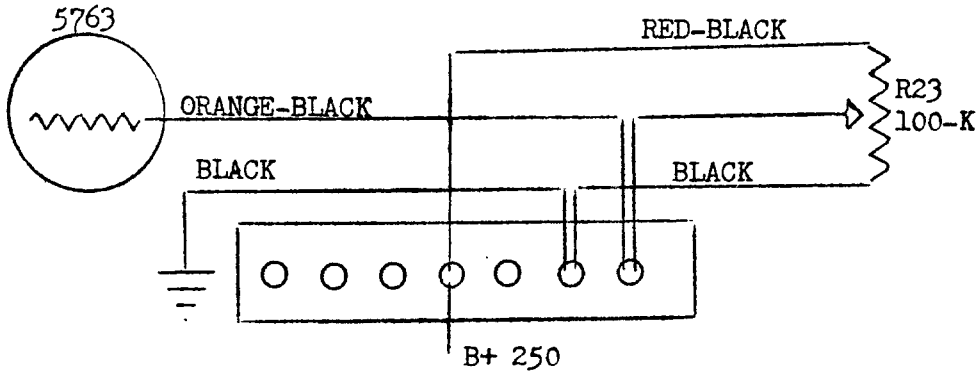

12AT7 Crystal oscillator

Omit C14-15-16 L8

Circuit changed to one below

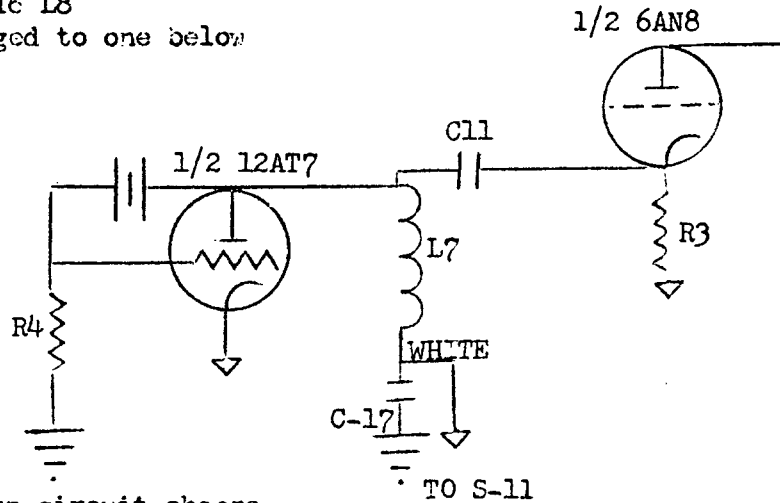

6146-screen circuit change

When Phone C switch is in CW position 218 Volt DC regulated is applied to 6146 screen. Added orange wire as shown in final production model.

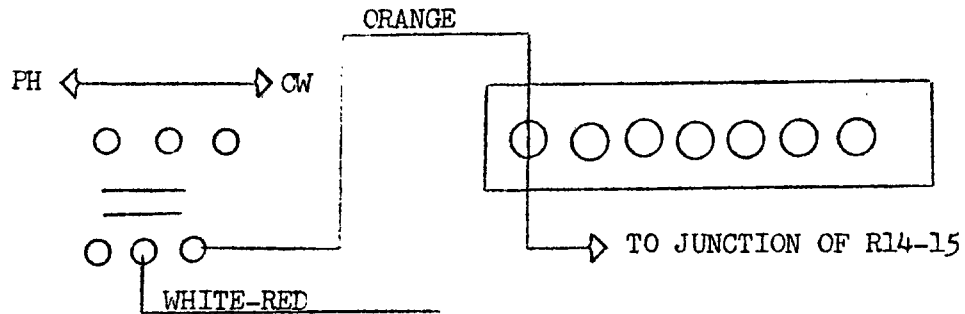

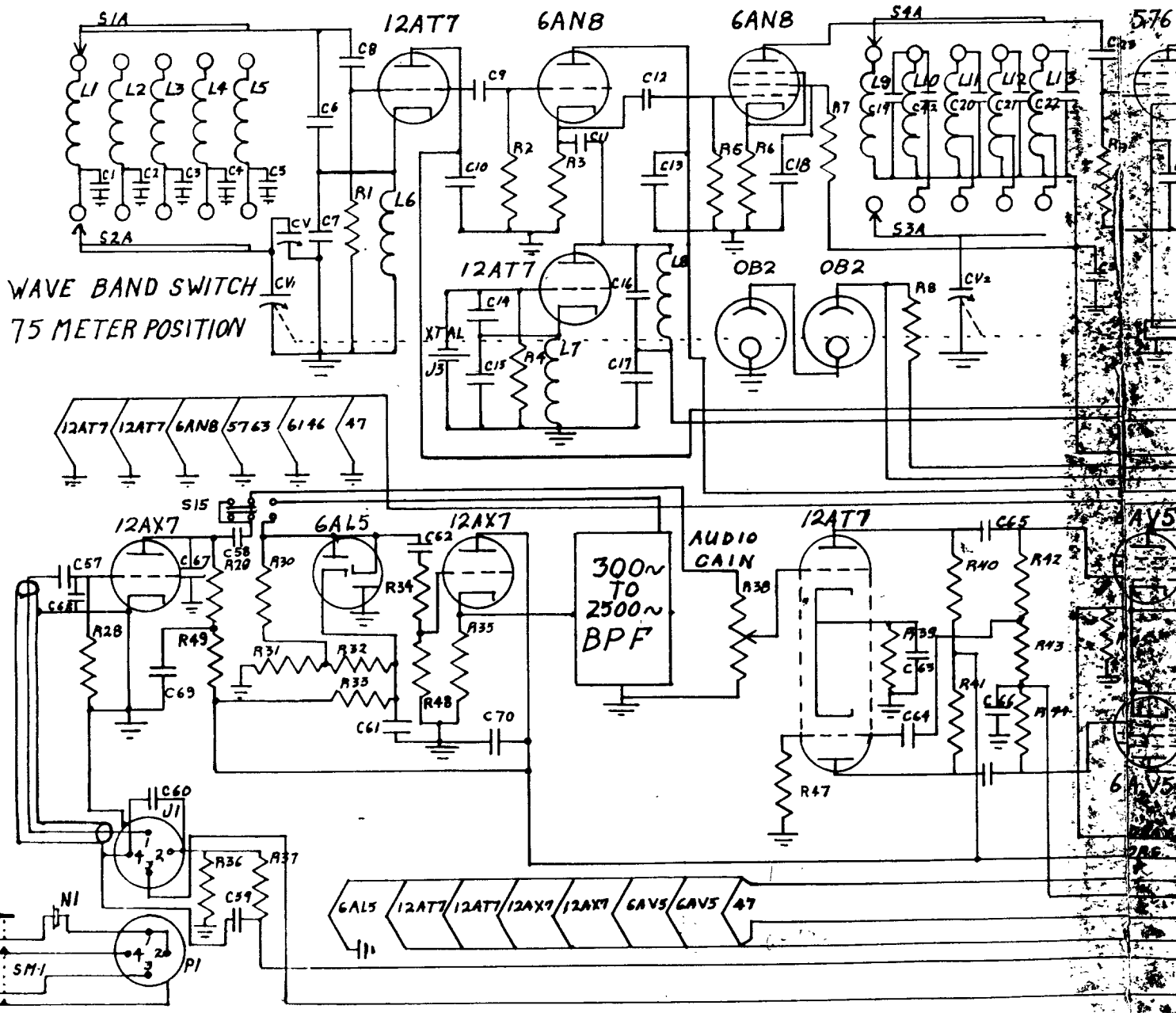

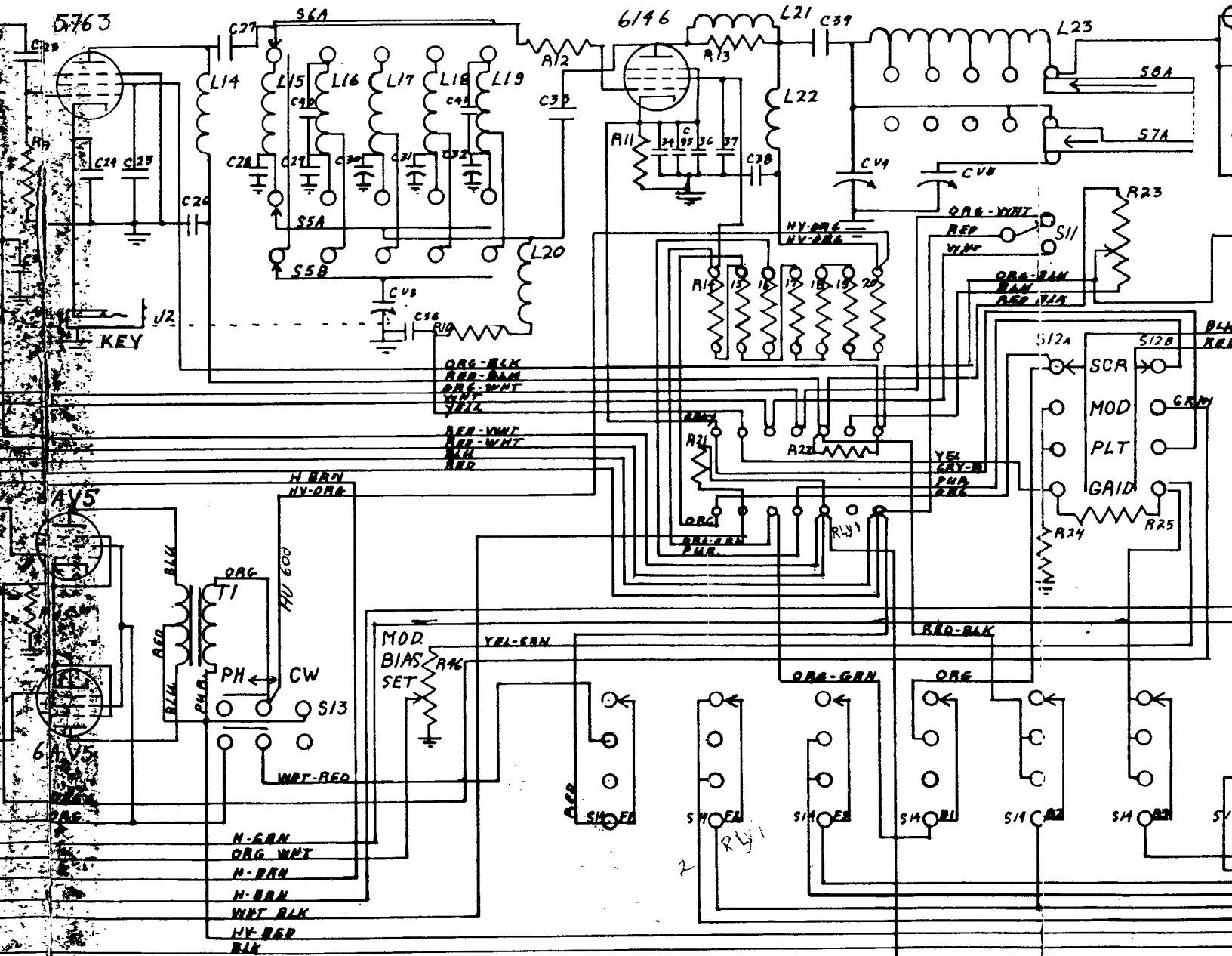

TALK

