

MULTI-ELMAC

Amateur Trans-citer

MODEL AF-67

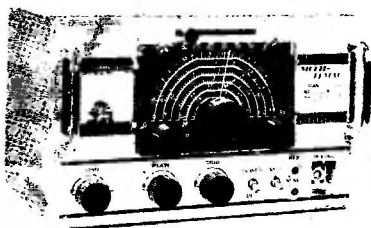

INSTALLATION AND OPERATING INSTRUCTION MANUAL

MULTI-PRODUCTS CO

OAK PARK, MICH.

Manufacturers of "MULTI-ELMAC" Products

MULTI-PRODUCTS COMPANY



Manufacturer of

MULTI-ELMAC

**RADIO COMMUNICATIONS
AND CONTROL EQUIPMENT**



21470 COOLIDGE HIGHWAY

OAK PARK 37, MICH.

Instruction Manual

FOR

MULTI-ELMAC TRANS-CITER—MODEL AF-67

SECTION 1—Description

1.1	General	3
1.2	Dimensions	3
1.3	Circuit Description	3
1.4	Tube Complement	3
1.5	Output	3
1.6	Audio	3
1.7	Power Supply	4
1.8	Power Connector	4
1.9	Accessories	4

SECTION 2—Installation and Operation

2.1	General Considerations	5
2.2	Mounting Methods	5
2.3	Antenna	5
2.4	T.V.I. Precautions	5
2.5	Power Supply Requirements	5
2.6	Controls	6
2.7	Power Supply Connections	6

SECTION 3—Service and Alignment

3.1	General	7
3.2	Tubes	7
3.3	Circuit Failures	7
3.4	General Alignment Instructions	7
3.5	V.F.O. Alignment	7
3.6	Buffer-Driver Alignment	8
3.7	Warranty	9

SECTION 4—Appendix

4.1	Parts List	10
4.2	Resistor Graph	13
4.3	Operating Voltage Chart	14
4.4	Control Layout	Drawing No. 217
4.5	Chassis Layout	Drawing No. 216
4.6	Typical Power Plug Connections	Drawing No. 219
4.7	Schematic Wiring Diagram	Drawing No. 182

SECTION 1

Description

1.1 GENERAL. The MULTI-ELMAC AF-67 Trans-citer is a ten tube variable frequency or crystal controlled seven band transmitter or exciter. All circuits are simultaneously switched to the desired band by a single bandswitch lever. Designed as a complete transmitter for mobile or fixed installations, or an exciter to drive a higher power transmitter. When used as an exciter the 500 ohm tap on modulation transformer can be used to drive the higher power modulators.

1.2 DIMENSIONS. The maximum external dimensions of the AF-67 Trans-citer, excluding projections of control knobs, is 11¼ inches wide, 7 inches high, and 8½ inches deep behind panel. Approximate weight is 18 pounds.

1.3 CIRCUIT DESCRIPTION. The AF-67 Trans-citer employs a variable frequency oscillator with output on either 1.75 to 2.0 Mc. or 3.5 to 4.0 Mc. In addition to the V.F.O. feature, two crystal positions are included for operation on two spot frequencies. Any crystal that will work straight through, double, or quadruple to the desired frequency may be used. The oscillator circuit employs a voltage regulator tube to maintain the plate voltage at a constant level. The multiplier stages are broad tuned with a front panel control for peaking the final grid, insuring best performance on all bands. The audio circuit is designed to use either a carbon microphone or a low output microphone such as a crystal or dynamic. A slide switch on the rear apron on the AF-67 Trans-citer sets up the circuit for use with either type of microphone. A reactance tube modulator is incorporated in the variable frequency oscillator circuit for narrow-band-frequency-modulation. The variable frequency oscillator dial end the meter scale are indirectly illuminated. The variable frequency oscillator dial scale is directly calibrated in megacycles for each of the amateur bands.

1.4 TUBE COMPLEMENT. The AF-67 Trans-citer is supplied complete with all tubes, tested in the individual unit, as follows:

6AK6	Oscillator
6BJ6	Reactance modulator
6AG5	Buffer-multiplier
6AQ5	R.F. Driver
6146	Final R.F. Amplifier
6AU6	Speech amplifier
12AU7	A.F. Driver
5881 (2)	P.P. Modulators
OB2	Voltage regulator
#44 (2)	Pilot bulbs

1.5 OUTPUT. The AF-67 Trans-citer is designed for use with a resonant antenna coupled to its output with a transmission line of 50 to 300 ohms impedance. Other impedance or balanced lines can be coupled through the use of an antenna tuning device. When used as an exciter the coupling link of the high powered final can be directly connected to the AF-67 with a suitable length of coaxial cable. The MULTI-ELMAC AF-67 is designed for a maximum plate power input of 60 (sixty) watts. Maximum ratings for this Trans-citer are 600 volts at 100 milliamperes; or 500 volts at 120 milliamperes. Full 100% modulation occurs when the modulator plate current swings to about 60% of the final plate current with normal voice frequencies.

1.6 AUDIO. The modulation transformer is provided with a 500 ohm output tap brought to the power plug for driving the grids of high powered modulators. The 5881's will deliver approximately 40 watts of audio with a plate supply of 500 volts.

- 1.7 POWER SUPPLY.** The AF-67 Trans-citer was intentionally designed to use an external power supply in order to permit (a) use of PMR-6A receiver power supply to supply the low level stages, (b) use of the AF-67 Trans-citer with an AC operated power supply at a fixed or portable location, (c) use of a dynamotor or vibrator supply in mobile installations, or (d) use of the Trans-citer as a driver-exciter for high powered transmitters. A suitable MULTI-ELMAC power supply MODEL PS-2V for portable or fixed station operation from 115 volt AC lines is available.
- 1.8 POWER CONNECTOR.** A 15 prong female connector is provided with each unit. The 15 prong connector allows all circuits to be arranged for maximum flexibility. Making it possible to use the AF-67 Trans-citer in various types of installations.
- 1.9 ACCESSORIES.** The following accessories are available for use with the AF-67 Trans-citer:
- PS-2V—A universal 115 volt AC power supply. (Supplies 6 or 12 volts AC for filaments and two separate high voltages.)
 - CFS-1—Cable with a 15 prong female connector and fanning strip to connect the AF-67 to the PS-2V power supply.

SECTION 2

Installation and Operation

- 2.1 GENERAL CONSIDERATIONS.** No two installations being similar, the individual owner of the AF-67 Trans-citer will vary his installation according to space and operating practices. Regardless of these variations whenever the Trans-citer is installed in a mobile unit, there are two essentials that must be observed for proper installation: (1) convenient location for operation, including ease of observation; (2) rigid mechanical mounting. The owner desiring to use the AF-67 as an exciter for higher powered equipment will have his own methods, etc. The usual standard practices for fixed or portable installations will suffice.
- 2.2 MOUNTING METHODS.** The construction of the cabinet on the AF-67 Trans-citer is such that it is readily adaptable to a hanging mount from the lower edge of the car dash board; or a fixed bottom bracket to the floor of the car. A brace to the fire wall will help make a more rigid installation. The AF-67 cabinet is equipped with felt feet for desk-top mounting in fixed or portable installations.
- 2.3 ANTENNA.** The MULTI-ELMAC AF-67 Trans-citer will perform most efficiently when coupled to an antenna resonated to the desired operating frequency. Standard practices should be used for antenna relay control. Typical mobile circuits are shown on drawing #219, page 17, of this manual. The coaxial output connector serves as an output terminal for the transmission line. Coaxial connectors allow the installation of low-pass filters between the Trans-citer and the antenna or antenna tuners. The type of antenna depends upon the individual's preference. The following types of antennas can be directly fed from the AF-67 without an antenna tuner:

- Center fed half-wave dipole
- Folded half-wave dipole
- Parasitic beams
- Vertical quarter-wave ground plane
- Base or center-loaded mobile whips
- Vertical half-wave dipoles, center fed
- Any antenna fed with low impedance untuned line.

Refer to the various handbooks on operating other types of antennas such as long wires, zepp fed, off center fed, lezy H, sterba curtains, phased arrays and the like.

- 2.4 T.V.I. PRECAUTIONS.** The MULTI-ELMAC Trans citer's circuitry is such that harmonics falling in the TV channels are at a minimum. The power plug leads are by-passed and other critical circuits designed for maximum harmonic attenuation. Under normal operating conditions the usual low-pass filter in the antenna transmission line, a brute-force filter in the AC power line, and a good efficient ground to the Trans-citer cabinet is sufficient to maintain a harmonic attenuation of 100 db down. Adequate shielding of stages and a completely shielded variable frequency oscillator make this possible.
- 2.5 POWER SUPPLY REQUIREMENTS.** For maximum flexibility the AF-67 Trans-citer power input is arranged for one or two* separate high voltage supplies. Filament input is arranged for either 6 volts @5.2 amp. or 12 volts @2.6 amp. AC or DC. (Refer to Drawing #219, page 17, for proper connections). Plate supply required: 500 volts max. @160 ma. and 250 volts max. @75 ma.

*Any single high voltage supply may be used with a dropping resistor as determined from the graph on page 13 of this manual. Any supply delivering 350 to 500 volts @235 ma. plus the proper filament voltage will suffice.

For mobile operation the power supply of the PMR-5A receiver may be used for the 250 volt supply and the usual dynamotor for the higher voltage supply. By using the receiver power supply for the low level stages the drain on the dynamotor is minimized resulting in more efficient dynamotor operation. More high voltage at a lower battery drain will be realized. Refer to drawing #219, page 17, for typical circuits.

2.6 CONTROLS. Sufficient controls have been incorporated for maximum flexibility, at the same time keeping operation simple. (See drawing #217, page 15).

Bandswitch	Switches all circuits to the desired amateur band simultaneously.
Meter switch	A 6 position meter function switch
	1. Final grid current, Final off.
	2. Final grid current, Final on.
	3. Final plate voltage, Final on.
	4. Not used. Final on.
	5. Modulator plate current, Final on.
	6. Final plate current, Final on.
Load control	Controls final load to antenna.
Plate tuning	Resonates final tank circuit.
Grid tuning	Tunes final grid.
Power "on-off" switch	Turns filaments on or off in a mobile installation, also controls primary power in an AC installation.
VFO switch	Connects VFO to receiver power supply for zero beating a carrier.
Mike jack	Microphone and push-to-talk circuit connections.
Key jack	Key connections for CW operation.
Crystal socket	Will hold two crystals in FT 243 holders.
VFO-Crystal switch	Selects either variable frequency operation or operation from either of the two crystals inserted in the socket above.
VFO control	Variable frequency oscillator frequency control. Reads directly in megacycles.
A.F. Gain control	Controls per-centage of modulation or frequency deviation when using NBFM.
AM-NFM-CW switch	(On rear of chassis) Selects either amplitude modulation, narrow band frequency modulation or AI emission.
High-low slide switch	(On rear of chassis) High position for crystal or dynamic microphones, low for carbon microphones.

2.7 POWER SUPPLY CONNECTIONS. A 15 prong plug is used for all connections and various possible combinations are diagrammed in drawing #219.

SECTION 3

Service and Alignment

- 3.1 GENERAL.** Satisfactory operation of this Trans-citer depends on several factors. Before removing a transmitter which is performing in an unsatisfactory manner, carefully inspect antenna connection, power cables and plugs, the storage battery and its connections (if a vehicular installation), the AC power source (if operated at a fixed location), and the microphone and relay connections. It is an aggravating waste of time and effort to remove and attempt to service a transmitter when the trouble is an external one.
- (a) **Antenna.** If the Trans-citer is functioning properly but does not load look for a broken antenna lead, bad relay contacts or inoperative relay, shorted transmission line or antenna insulator.
 - (b) **Storage battery.** Check periodically the terminal voltage, specific gravity, level of electrolyte, and the tightness of connections. Check the battery voltage at the Trans-citer power plug with the Trans-citer operating and drawing full load.
 - (c) **Cables and plugs.** The initial installation should locate all cables and plugs where they will not be exposed to physical shock or subjected to twisting and bending.
- 3.2 TUBES.** Even though modern methods produce more reliable tubes than ever, the first source of trouble is likely to be a defective tube. Tube failure will produce low grid drive, low plate current, intermittent operation, or a completely dead transmitter. Where a tube change is made in the R.F. portion of the Trans-citer it should be replaced with the same make of tube. If this is not possible the circuits may have to be realigned according to paragraphs 3.5 and 3.6 of this section.
- 3.3 CIRCUIT FAILURES.** Excluding tubes, the most common source of circuit failure, will invariably be found in the many resistors and capacitors within the Trans-citer. A defective resistor or condenser can usually be found by a point-to-point continuity test, although a careful visual inspection will often show the defective part, such as a charred resistor. The operating voltage chart on page 14 permits a careful check of operating elements. All measurements are taken with the final plate OFF, bandswitch in the 80 meter position, VFO set to 3.8 megacycles, final grid current resonated for maximum grid current, crystal-VFO switch in VFO position, and audio gain control on minimum. A 20,000 ohms per volt meter is used. (DO NOT use a vacuum tube voltmeter since it will read erroneously in an R.F. field). These measurements were taken using a PS-2V power supply and a line voltage of 117 volts AC. Any power supply can be used that will give the same high voltage.
- 3.4 GENERAL ALIGNMENT INSTRUCTIONS.** Thoroughly familiarize yourself with the layout of all coils and tuning adjustments as shown on drawing #216, page 16, before beginning an alignment. Check all brass slug adjusting screws to make sure that they are not worn so much that they will not hold their setting. If they are too worn to be serviceable they must be replaced. Check the pointer to see that it is aligned properly with respect to the stops on the VFO dial. Check to see that the sprocket and chain are tight on the switch shafts and that the switches are all in their proper position.
- You will need an accurate receiver and an accurate signal generator and/or crystals to spot the amateur band edges.
- An alignment job can never be any better than the equipment with which the Trans-citer was aligned.
- 3.5 VARIABLE FREQUENCY OSCILLATOR ALIGNMENT.**
- Turn the meter switch to the left "G" position, final off.
- Set bandswitch lever to the 80 meter position.

Set VFO-crystal switch to the VFO position.
Set the VFO dial to 3.5 megacycles.
Set signal generator at 3.5 megacycles, tune receiver to 3.5 megacycles.
Apply plate power to VFO.
Adjust screw #1 until a beat is obtained at 3.5 Mc.
Set the VFO dial to 4.0 megacycles.
Set signal generator and receiver to 4.0 megacycles.
Adjust trimmer #2 for a beat at 4.0 megacycles.
Readjust at 3.5 megacycles, then again at 4.0 megacycles.
It may take several excursions between 3.5 and 4.0 megacycles before a good alignment is achieved.

The 160 meter band will automatically be correct after the 80 meter band is correctly aligned.

Set the bandswitch lever to the 10 meter position.
Set the VFO dial to 29 megacycles.
Set the signal generator and receiver to 29 megacycles.
Adjust screw #3 until a beat is obtained at 29 megacycles.
The remainder of the 10 meter band should be correct.

The 40 meter band will be correct after the 10 meter band is aligned.

Set the bandswitch lever to the 20 meter band.
Set the VFO dial to 14.2 megacycles.
Set the signal generator and receiver to 14.2 megacycles.
Adjust trimmer #4 for a beat at 14.2 megacycles.
The remainder of the 20 meter band should be correct.

The 15 meter band will be correct after the 20 meter band is aligned.

3.6 BUFFER — DRIVER ALIGNMENT.

Turn meter switch to the left "G" position, final off.
Set bandswitch lever to the 160 meter position.
Set VFO-crystal switch to the VFO position.
Set the VFO dial to 1900 kilocycles.
Set the final grid tuning condenser at about the half capacity position.
Adjust screw #11 for maximum grid drive as shown on the meter.

Set bandswitch lever to the 80 meter position.
Set VFO dial to 3.75 megacycles.
Set final grid tuning condenser at about the half capacity position.
Adjust screw #12 for maximum grid drive as shown on the meter.

Set bandswitch lever to the 40 meter position.
Set VFO dial to 7.2 megacycles.
Set final grid tuning condenser at about the half capacity position.
Adjust screw #10 for maximum grid drive as shown on the meter.

Set the bandswitch lever to the 15 meter position.
Set the VFO dial to 21.3 megacycles.
Set the final grid tuning condenser at about the half capacity position.
Adjust screw #8 and #9 for maximum grid drive as shown on the meter.

Set the bandswitch lever to the 20 meter position.
Set the VFO dial to 14.2 megacycles.
Set the final grid tuning condenser at about the half capacity position.
Adjust screw #5 for maximum grid drive as shown on the meter.

Set the bandswitch lever to the 10 meter position.

Set the VFO dial to 28.5 megacycles.

Set the final grid tuning condenser at about the half capacity position.

Adjust screw #6 and #7 for maximum grid drive as shown on the meter.

11 meter band operation is possible using crystal control only.

If 11 meter operation is desired, set the bandswitch to the 10 meter position. Insert the proper crystal into the crystal socket and set the VFO—crystal switch to the corresponding position and

adjust the final grid tuning condenser for proper grid drive. Tune up the final plate and loading condenser just the same as for 10 meters.

NOTE: When tuning the buffer and driver slugs it is well to use a grid dip meter or wave meter to make sure all the coils are tuned to the proper bands or harmonics.

- 3.7 WARRANTY.** This Trans-citer has been carefully tested and was shipped from the factory in perfect operating condition. If the set arrives damaged in transit, it is important that you file claim immediately with the carrier.

THE MULTI-PRODUCTS COMPANY, warranting this Trans-Citer to be free from defective material and workmanship, agrees to repair or replace, without charge, any defective unit or accessory within 90 (Ninety) days from the date of sale to the original purchaser, providing the equipment is returned to the manufacturer properly packed and shipped prepaid by the owner. All such articles returned under this warranty, must be preceded or accompanied with a letter outlining the defects.

Any failure of the equipment following modification by the user, or occurring through application of power supply voltages other than those specified in this instruction manual shall not constitute a defect within this warranty.

This warranty shall not be in effect if the owners registration card is not properly filled out with the model number, serial number, purchase date, from whom purchased, and forwarded to the MULTI-PRODUCTS COMPANY.

The manufacturer reserves the right to make any changes in this unit without obligating itself with respect to prior production.

Section 4

Appendix

4.1 PARTS LIST.

R11	47K	ohms	1 watt	10%
R12	47K	ohms	1 watt	10%
R20	1000	ohms	1 watt	10%
R21	100K	ohms	½ watt	10%
R22	10K	ohms	1 watt	10%
R23	470K	ohms	1 watt	10%
R24	390	ohms	1 watt	10%
R25	47K	ohms	1 watt	10%
R26	220K	ohms	1 watt	10%
R31	33K	ohms	1 watt	10%
R32	180	ohms	1 watt	10%
R33	47K	ohms	1 watt	10%
R34	1000	ohms	1 watt	10%
R35	1200	ohms	1 watt	10%
R36	470	ohms	1 watt	10%
R37	68	ohms	½ watt	10%
R38	180	ohms	1 watt	10%
R41	100K	ohms	1 watt	10%
R42	180	ohms	1 watt	10%
R51	27K	ohms	1 watt	10%
R52	270	ohms	½ watt	5%
R53	25K	ohms	10 watt	W.W.
R54	6.8	ohms	1 watt	5%
R55	1000	ohms	½ watt	5%
R61	22K	ohms	½ watt	10%
R62	470K	ohms	½ watt	10%
R63	2200	ohms	½ watt	10%
R64	1000	ohms	1 watt	10%
R65	470K	ohms	½ watt	10%
R66	1 meg	ohms	½ watt	10%
R67	47K	ohms	2 watt	10%
R68	270	ohms	½ watt	10%
R70	500K	ohms	potentiometer.	
R71	680	ohms	½ watt	10%
R89	6.8	ohms	1 watt	5%
R90	750K	ohms	2 watt	5%
R101	10K	ohms	10 watt	W.W.

C11A)
C11B)
C11C)

VFO tuning condenser. Part #196-3

C12	27mmf. N750	2½%	tubular ceramic
C13	75mmf. variable.		Part #CT1B075
C14	33mmf. NPO	2½%	tubular ceramic
C15	35mmf. variable		Part #CT1B035
C16	75mmf. NPO	2½%	tubular ceramic
C17	.001 mfd.	500 volt	mica
C18	.005 mfd.		disc ceramic

C19 .005 mfd. disc ceramic
 C20 .01 mfd. disc ceramic
 C21 33mmf. NPO 2½% tubular ceramic
 C22 33mmf. NPO 2½% tubular ceramic
 C23 .005 mfd. disc ceramic
 C24 250mmf. GP tubular ceramic
 C25 .01 mfd. disc ceramic
 C26 .01 mfd. disc ceramic
 C31 120mmf. NPO 10% tubular ceramic
 C32 .005 mfd. disc ceramic
 C33 1.5mmf. tubular ceramic
 C34 .005 mfd. disc ceramic
 C35 .005 mfd. disc ceramic
 C36A} Dual 25mmf. variable. Part #196-2
 C36B}
 C41 100mmf. GP tubular ceramic
 C42 .005 mfd. disc ceramic
 C43 .005 mfd. disc ceramic
 C44 .005 mfd. disc ceramic
 C45 5mmf. tubular ceramic
 C51 100mmf. GP tubular ceramic
 C52 .005 mfd. disc ceramic
 C53 .001 mfd. 1000 volt tubular ceramic
 C54 .005 mfd. disc ceramic
 C55 .005 mfd. 1600 volt disc ceramic
 C56 .001 mfd. 1000 volt tubular ceramic
 C57A} Dual 140mmf. variable. Part #MC-912A
 C57B}
 C58A} Dual 485mmf. variable. Part #196-1
 C58B}
 C59 .005 mfd. disc ceramic
 C61 .002 mfd. disc ceramic
 C62 10 mfd. 50 volt tubular electrolytic
 C63 .03 mfd. 600 volt tubular paper
 C64 8 mfd. 450 volt tubular electrolytic
 C65 .005 mfd. disc ceramic
 C66 .005 mfd. disc ceramic
 C71 10 mfd. 50 volt tubular electrolytic
 C101 .1 mfd. 600 volt tubular paper
 C102 .005 mfd. disc ceramic
 C103 .005 mfd. disc ceramic
 C104 .005 mfd. disc ceramic
 C105 .001 mfd. 1000 volt tubular ceramic
 L11 Oscillator coil Part #179
 L12 Oscillator coil Part #180
 L13 2½ MH R.F. choke
 L14 Oscillator plate coil Part #B-40
 L31 Buffer plate coil Part #B-40
 L32 Buffer plate coil Part #D-20
 L38 Buffer plate coil Part #G-80 (Less Iron Core)
 L41 Driver plate coil Part #G-160
 L42 Driver plate coil Part #G-80
 L43 Driver plate coil Part #G-40
 L44 Driver plate coil Part #G-20
 L45 Driver plate coil Part #G-15
 L46 Driver plate coil Part #G-10
 L51 2½ MH R.F. choke

L52	.47 Microhenry R.F. choke	
L53	2½ MH R.F. choke, 250 MA.	
L54	160 & 80 meter plate coil Part #183	
L55	40 & 20 meter plate coil Part #184	
L56	15 & 10 meter plate coil Part #185	
L57	2½ MH R. F. choke	
T1	Class AB2 driver transformer. Part #121A7	
T2	Modulation transformer. Part #121A8	
SW11A)	VFO section of bandswitch. Part #201	
SW11B)		
SW11C)		
SW11D)		
SW12A)	VFO-CRYSTAL selector switch. Part #176	
SW12B)		
SW12C)		
SW31)	Buffer driver bandswitch. Part #202	
SW41)		
SW51A)	Final plate bandswitch. Part #175	
SW51B)		
SW51C)		
SW52A)	Meter switch and final on-off switch. Part #178	
SW52B)		
SW52C)		
SW61A)		Part #177B
SW61B)	AM-NFM-CW switch	
SW81A)		Part #177A
SW81B)		
SW62	Carbon-crystal microphone switch. S.P.S.T. slide switch	
SW101-VFO.	Spotting Switch S. P. D. T. Toggle Switch	
SW102	Power on-off switch. S.P.S.T. toggle switch.	
B1	22½ volt "E" battery. Burgess #U15	
PL1)	#44 pilot bulbs (Do not use any other number.)	
PL2)		
M	0 to 1 milliamperemeter.	
V1	6AK6	Oscillator tube
V2	6EJ6	Reactance modulator tube
V3	6AG5	Buffer-multiplier tube
V4	6AQ5	R.F. driver tube
V5	6146	R.F. final amplifier tube
V6	6AU6	Speech amplifier tube
V7	12AU7	A.F. driver tube
V8	5881	Modulator tube
V9	5881	Modulator tube
V10	OE2	Voltage regulator tube
Bandswitch lever		Part #191A
Sprocket		Part #159
Sprocket chain		Boston #1 ladder chain
Pull handle		Part #158
Plastic dial escutcheon		Part #151CT
Serial plate		Part #187A
AM-NFM-CW switch linkage		Part #192
Name plate 10¼" x 2½"		Part #162A
VFO dial scale		Part #215
Cabinet		Part #195
Front Panel		Part #186

**USE TUNG-SOL 6AQ5
TUBE ONLY FOR BEST RESULTS**

4.2 - RESISTOR GRAPH

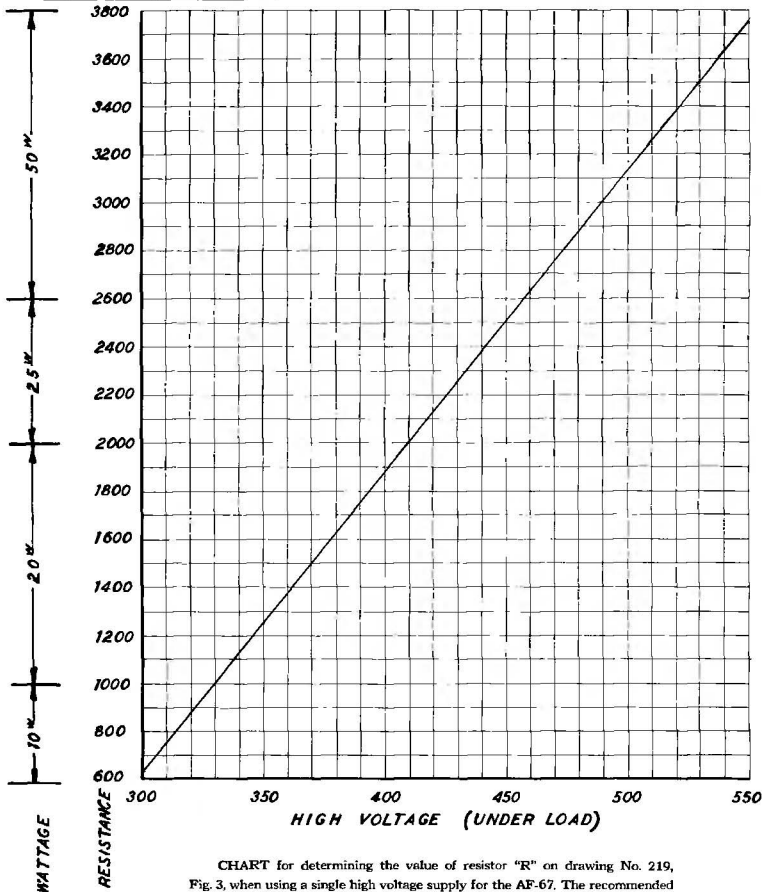

CHART for determining the value of resistor "R" on drawing No. 219, Fig. 3, when using a single high voltage supply for the AF-67. The recommended wattage rating of this resistor is shown at the extreme left above. Be sure to use the actual voltage supplied by the power supply under load when using the chart above.

4.3 — OPERATING VOLTAGE CHART

PIN No. →	1	2	3	4	5	6	7	8	9	
TUBE No. ↓										
V3 6AG5	—9*	1.0	zero (12.6)**	6.3**	120	145	1.0	—	—	
V4 6AQ5	—8.5*	6.7	6.3**	zero	220	220	—8.5*	—	—	
V5 6146	zero	zero (12.6)**	Note 1	zero	—	zero	6.3**	zero	—	
V6 6AU6	zero	zero	6.3**	zero	35	40	1.5	—	—	
V7 12AU7	210	zero	7.6	zero	zero (12.6)**	210	zero	7.6	6.3**	
V8 5881	zero	zero (12.6)**	Note 1	220	—22.5	—	6.3**	zero	—	
V9 5881	zero	6.3**	Note 1	220	—22.5	—	zero	zero	—	
V10 0B2	108	zero	—	zero	108	—	zero	—	—	

This chart serves only as a guide, individual sets may vary from these readings.

All measurements made with a 20,000 ohms per volt voltmeter, using a PS-2V power supply or equivalent. Bandswitch lever in the 80 meter position, VFO dial set at 3.8 megacycles, audio gain control set at minimum, VFO—CRYSTAL switch set in the VFO position, meter switch set to the first "G" (plate off) position, final grid tuning condenser resonated for maximum grid current, and the AM-NFM-CW switch set in the AM position.

Note 1—These readings depend upon final plate supply voltage.

* These measurements taken with a 100,000 ohm 1 watt carbon resistor on the end of the negative voltmeter probe.

** Either AC or DC. Numbers in brackets are in effect when connected for 12 volt operation.

4.4- CONTROL LAYOUT

BANDSWITCH
SWITCHES ALL CIRCUITS TO THE DESIRED BAND SIMULTANEOUSLY.

STEP 2

METER
HAS THREE SCALES:
0-5 MILLIAMPERES
0-150 MILLIAMPERES
0-750 VOLTS D.C.

METER SWITCH
SIX POSITIONS.
ONE (O) READS FINAL GRID CURRENT WITH FINAL AMPLIFIER OFF. (FINAL IS ON IN ALL OTHER METER SWITCH POSITIONS)
TWO (G) READS FINAL GRID CURRENT WITH THE FINAL AMPLIFIER ON.
THREE (V) READS FINAL PLATE VOLTAGE.
FOUR (NOT USED).
FIVE (M) READS MODULATOR PLATE CURRENT.
SIX (P) READS FINAL AMPLIFIER PLATE CURRENT.

STEP 3, 7, 8

LOAD CONTROL PLATE TUNING CONTROL

THESE TWO CONTROLS ARE ALWAYS TUNED TOGETHER.
FIRST WITH THE LOAD CONTROL SET AT MINIMUM (COUNTER-CLOCKWISE) RESONATE PLATE TUNING CONTROL (METER SWITCH IN POSITION "G" AND TUNE FOR LOWEST PLATE CURRENT)
NEXT TURN LOAD CONTROL CLOCKWISE SLOWLY UNTIL PLATE CURRENT READS APPROXIMATELY 100 TO 120 MILLIAMPERES AGAIN RESONATE PLATE TUNING CONTROL IF THE PLATE CURRENT DROPS BELOW THE DESIRED PLATE CURRENT INCREASE THE SETTING OF THE LOAD CONTROL.
ALWAYS RESONATE PLATE TUNING CONTROL AFTER LOAD CONTROL HAS BEEN CHANGED.

STEP 7

STEP 7

FINAL GRID TUNING

ADJUST FOR PROPER FINAL GRID CURRENT. (2½ TO 5 MA)

STEP 8

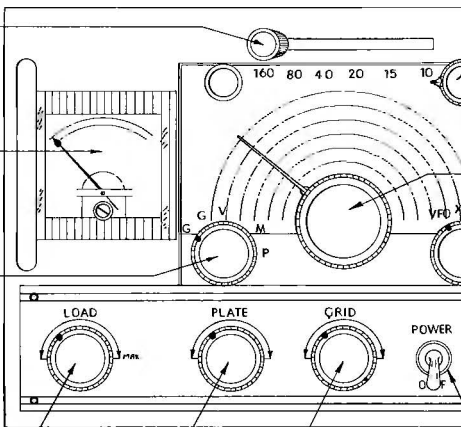

OPERATING INSTRUCTIONS

1. Turn on Filaments and allow about two minutes warm-up time.
2. Select band desired with bandswitch lever.
3. Select type of operation desired, crystal or V.F.O. (for these instructions consider V.F.O. operation). Also select type of emission desired; AM or CW. Selected by a switch on the rear apron of the transmitter.
- 4a. Set V.F.O. dial to desired frequency in megacycles.
—OR—
4b. Flip V.F.O. spotting switch to the upper position and turn V.F.O. control until zero beat is obtained with the signal on whose frequency you wish to transmit. When this adjustment is made flip the V.F.O. spotting switch to down position.
5. Set the meter switch to the first (G) position.
6. Operate the push-to-talk button on the microphone or operate after "transmit-receiver" switch and adjust grid tuning control for proper grid current to 5 milliamperes.
7. Set meter switch to (P) position and load the transmitter to the antenna. (Antenna must be resonant at the frequency of operation is desired. Grid current should now be checked under second (G) position.
8. Set meter switch to position (M) and check modulator current (when modulation). The A.F. gain control located in the upper right corner of the V.F.O. dial controls the per-centage of modulation. Modulator plate current should swing to about 60 to 70% of Final amplifier plate current value when modulation.

AF-67 OPERATING INSTRUCTIONS

MULTI-PRODUCTS CO.

10-1-53
G.E.U.

217

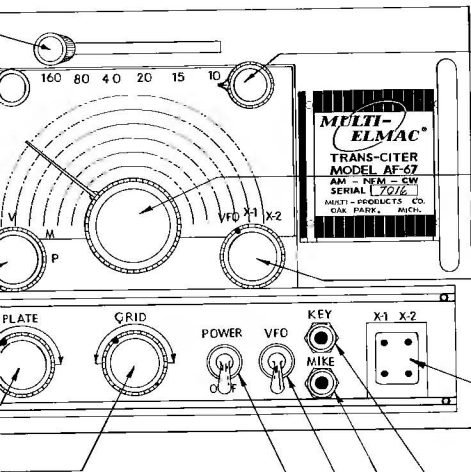

A.F. GAIN CONTROL

CONTROLS PER-CENTAGE OF MODULATION WHEN USING "AM".

CONTROLS DEVIATION WHEN USING "NFM".

CONTROLS A.F. GAIN WHEN USING THE ELMAC AF-67 TRANS-CITER AS A SPEECH AMPLIFIER-EXCITER FOR A HIGHER POWER TRANSMITTER.

STEP
8

V.F.O. CONTROL

A VERNIER DRIVE CONTROL THAT INDICATES THE FREQUENCY OF OPERATION DIRECTLY IN MEGACYCLES.

STEP
4A

V.F.O. - CRYSTAL SELECTOR SWITCH

THE ELMAC AF-67 TRANS-CITER CAN BE OPERATED FROM THE BUILT-IN V.F.O. OR EITHER OF TWO CRYSTALS INSERTED INTO THE SOCKET BELOW.

STEP
3

CRYSTAL SOCKET

WILL HOLD TWO CRYSTALS IN FT 243 HOLDERS.

KEY JACK

USES A TWO CIRCUIT PHONE PLUG SUCH AS PL-55 OR EQUAL.

MICROPHONE JACK

ALSO CARRIES THE PUSH-TO-TALK CIRCUIT. USES A THREE CIRCUIT PHONE PLUG SUCH AS MALLORY TYPE 76 OR EQUAL.

V.F.O. SPOTTING SWITCH

WHEN IT IS DESIRED TO ZERO-BEAT A SIGNAL FLIP THIS SWITCH TO THE UPPER POSITION. THIS CONNECTS THE V.F.O. B PLUS LEAD TO PIN #8 ON THE POWER PLUG WHICH CAN BE CONNECTED TO THE RECEIVER B SUPPLY.

STEP
4B

POWER ON-OFF SWITCH

CONTROLS FILAMENTS ON D.C. OPERATION. CONTROLS THE MAIN A.C. LINE ON 115 VOLT A.C. OPERATION.

STEP
1

OPERATING INSTRUCTIONS

Is and allow about two minutes warm-up time.
ired with bondswitch lever.

peration desired, crystal or V.F.O. (for these instructions we will
operation). Also select type of emission desired; AM, NFM, or
y a switch on the rear apron of the trans-citer.
to desired frequency in megacycles.

ing switch to the upper position and turn V.F.O. control until a
stained with the signal on whose frequency you wish to operate.
stment is made flip the V.F.O. spotting switch to down position.
switch to the first (G) position.

ush-to-talk button on the microphone or operate alternate "trans-
switch and adjust grid tuning control for proper grid drive (2½
res).

h to (P) position and load the transmitter to the antenna as ex-
Note: Antenna must be resonant at the frequency on which
nsired. Grid current should now be checked under load in the
ition.

h to position (M) and check modulator current (when using AM
he A.F. gain control located in the upper right corner of the
ontrols the per-centage of modulation. Modulator plate current
about 60 to 70% of final amplifier plate current value for 100%.

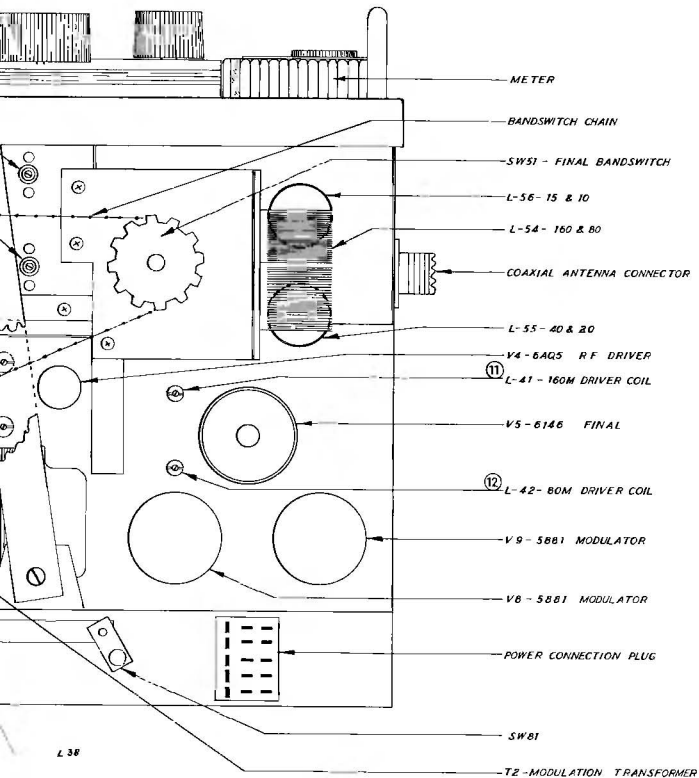

L 38

4.6-TYPICAL POWER PLUG CONNECTIONS

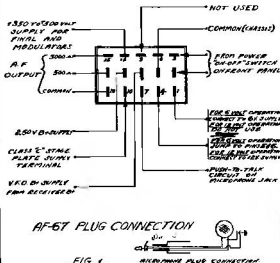

FIG. 1

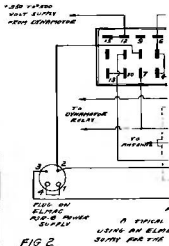

FIG. 2

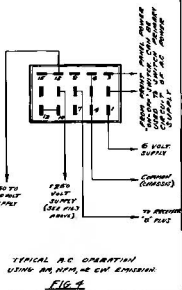

FIG. 4

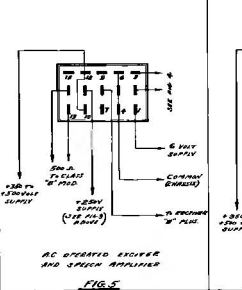
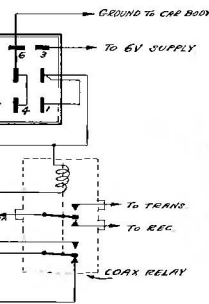
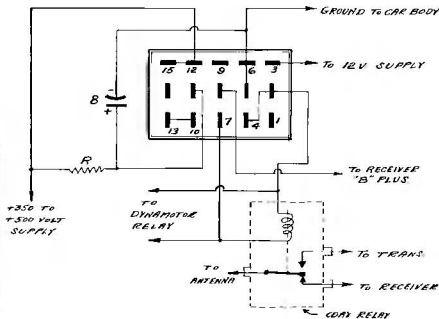

FIG. 5



FOR 6 VOLT DC OPERATION.
 A TYPICAL MOBILE INSTALLATION
 USING A COMMON HIGH VOLTAGE SUPPLY.
 THE VALUE OF RESISTIVE
 "R" IS DETERMINED FROM THE CHART



FOR 12 VOLT OPERATION.
 A TYPICAL MOBILE INSTALLATION USING A
 COMMON HIGH VOLTAGE SUPPLY. THE VALUE OF RESISTIVE
 "R" IS DETERMINED FROM THE CHART

FIG. 3

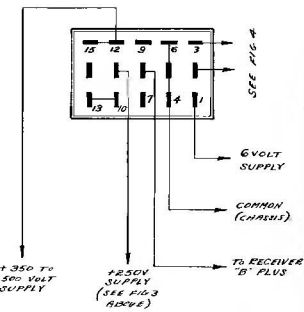

A.C. OPERATED EXCITER, DRIVING
 CLASS "B" LINEAR AMPLIFIER
 (AM ONLY)

FIG. 6

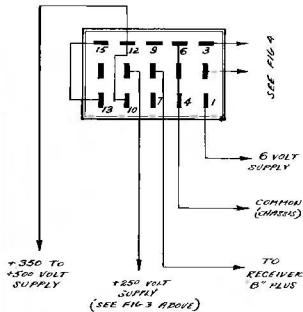

A.C. OPERATED EXCITER DRIVING
 CLASS "C" AMPLIFIER - NFM OR CW ONLY

FIG. 7

4.5-CHASSIS LAYOUT

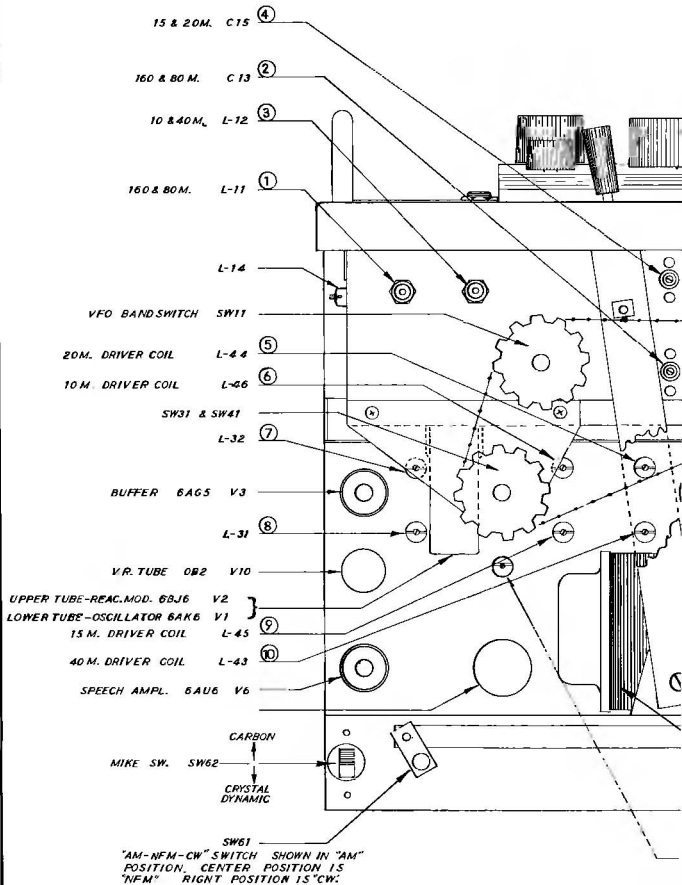

AF-67 TUBE LAYOUT MPC. GE

4.7 - SCHEMATIC WIRING DIAGRAM

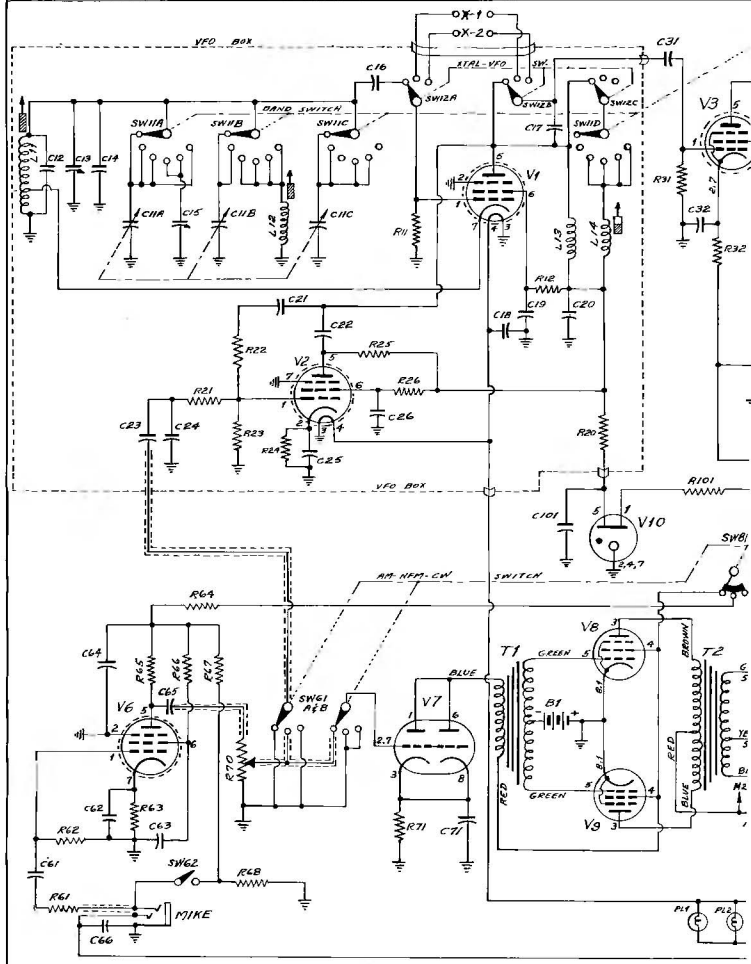

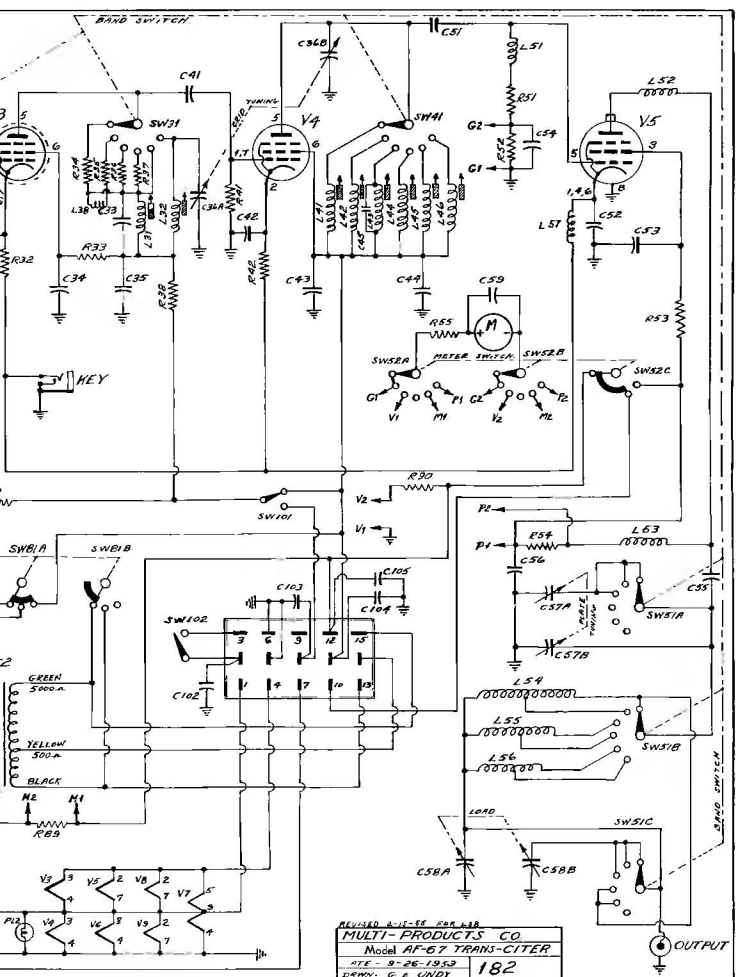

REVISED 2-11-55 FOR MAB
MULTI-PRODUCTS CO.
 Model AF-67 TRANS-CITER
 RTE - 9-26-1953
 DRAWN: G. E. UNDY

182

MULTI - ELMAC

M-1051 POWER SUPPLY KIT

ASSEMBLY INSTRUCTIONS

1. Check all material shipped against parts list.
2. Assemble mechanical parts in the following order:
 - Primary-Secondary terminal strips (12 Terminal)
 - Transformers
 - Fuse holders
 - Vibrator sockets and Vibrator grounding clips
 - Octal socket
 - Selenium Rectifiers
 - Relay
 - Primary Input screw terminals
 - Filter Choke
 - Insert Vibrators and Fuses

(DO NOT INSTALL MAIN FILTER CONDENSERS 70/125 Mfd UNTIL WIRING IS COMPLETED.)
3. Wire as per attached pictorial assembly drawing the following order.
 - A. Solder back of primary ground terminal screw.
 - B. Wire in primary buss bar from "HOT" terminal screw to fuse holders.
 - C. Wire transformer primaries for input voltage desired. Pictorial diagram shows 12 volt primary connections. Refer to drawing 462 for necessary changes for 6 volt operation.
 - D. Wire secondary transformer connections to terminal strip, control sockets, relays, seleniums, etc.
 - E. Install main filter condensers and complete wiring as per drawing.
4. Test
 - A. Connect wires from Selenium Rectifiers to desired Secondary Taps.
 - B. Install cover plate over selenium section and bottom plate to protect operator from high voltage.
 - C. Install with equipment as shown in instruction manual.

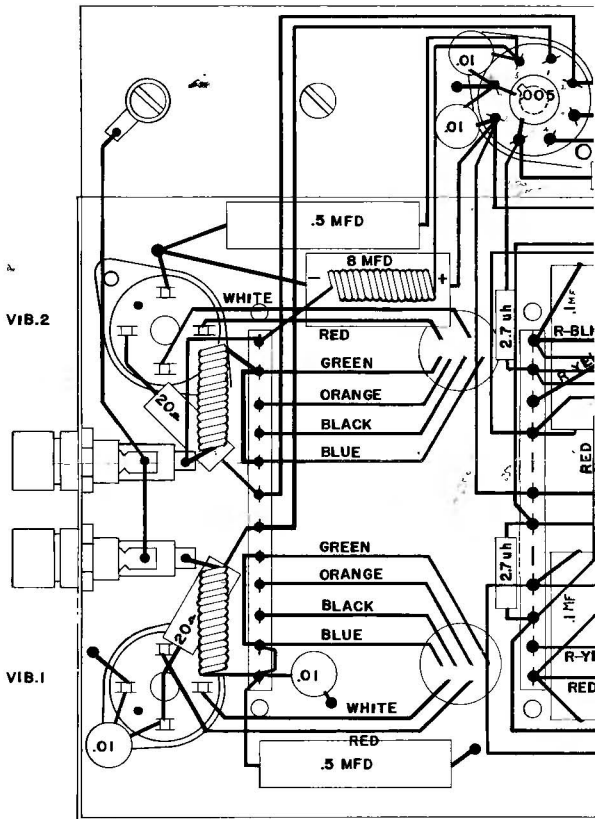
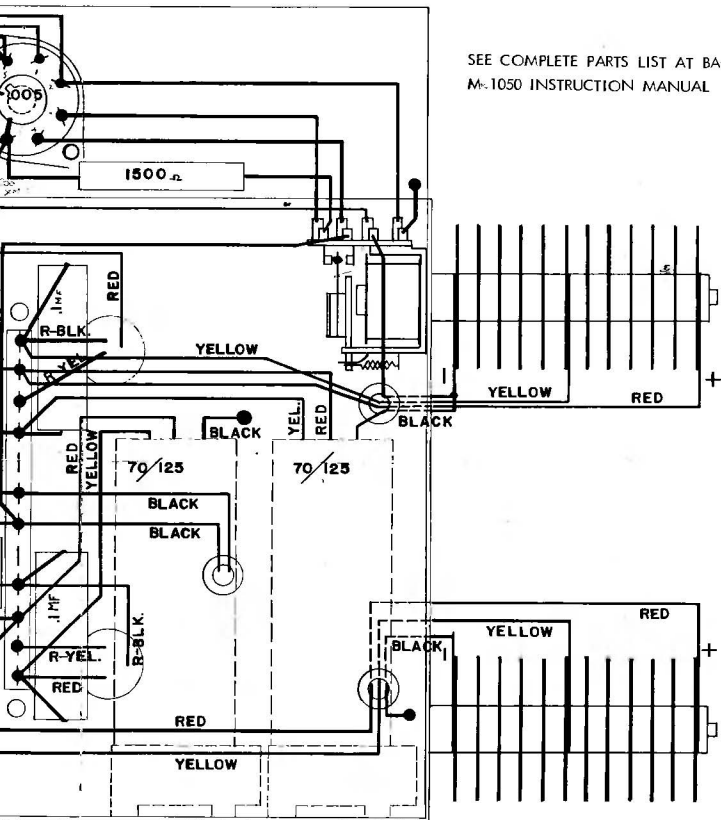

DIAGRAM OF SUPPLY WIRED
SEE INSTRUCTION MANUAL

SEE COMPLETE PARTS LIST AT BACK OF
M-1050 INSTRUCTION MANUAL



WIRED FOR 12 VOLT PRIMARY.
MANUAL FOR 6 VOLT PRIMARY WIRING.

MULTI-ELMAC

MODEL M1050/M1051 (KIT)

6/12 VOLT MOBILE POWER SUPPLY

T-1

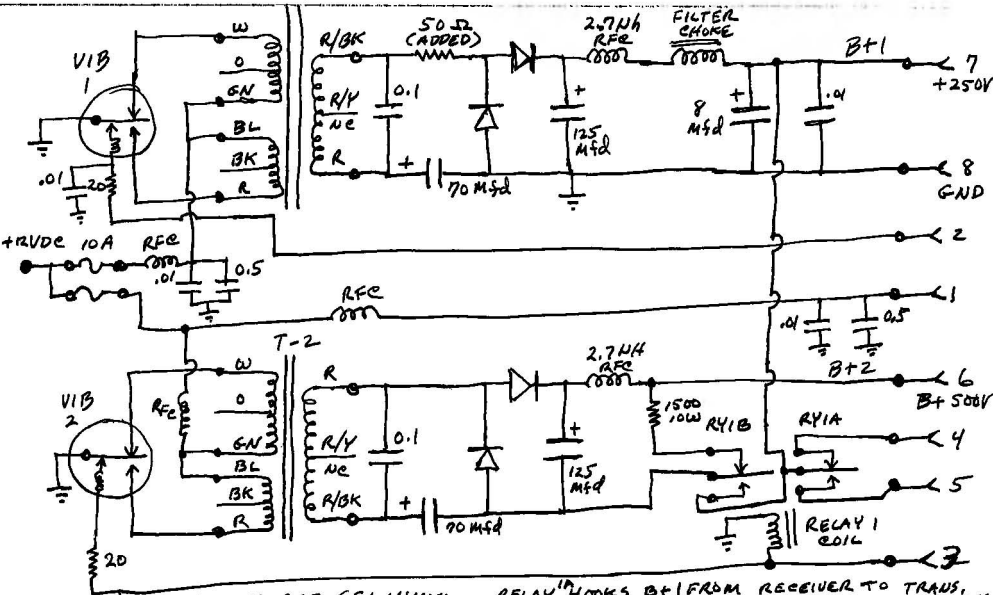

DIODES ARE SELINUM

RELAY^{1A} HOOKS
" 1B "

B+1 FROM RECEIVER TO TRANS.
B+2 SUPPLY ON TOP OF B+1 ON TRANS.