

## 1. Errors in the NC-300 Instruction Book

- a. Connections shown in Figure 2, Page 5.  
Connections shown connecting remote RF gain control should be such that remote control connects to STDBY and PIN 1 of accessory socket. Drawing is incorrect in that it shows control connected to Pin 8 of the accessory socket. This is B plus.
- b. Page 8 under "AFG" states that the RF gain control is normally set to full on for phone operation, page 9 under Phone Reception indicates that the RF gain control must be run full on to obtain proper AVC action. This is contradictory with page 11 under Measurement of Signal Strength where reduction of the RF gain is advised to bring the reading on the S meter to S-1. Page 11 is correct since the amount of reduction made to have the meter read S-1 is small enough to have no effect on the AVC action.
- c. Page 14 indicates pin voltages. V-11 the OB2 should have pins 1 and 5 with 107 volts and pins 2,3,4,6 and 7 zero volts.
- d. On page 23 the schematic indicates grounding of condenser C-15 in T-3. This is incorrect. The condenser connects from terminal B to terminal C. Terminal D is grounded. There is no connection made to the shield can inside the transformer as indicated on the diagram.
- e. On the schematic diagram the crystal filter switch S-4 shows C-17 on Position 1. Position 1 and 2 are reversed on this side of the switch. C-17 should be on position 2 and 1 should be open.

## 2. Changes made after books were printed but prior to production.

- a. Coil - T-28 has tapped winding instead of separate primary. (30-35 mc range for converters).
- b. Resistor R-45, 2200 ohms changed to 3300 ohms.
- c. A new condenser and coil were added to the mixer partition to form an image trap on the 14 mc band to raise the image ratio from 60 db to 80 db. This trap is adjusted by tuning the receiver to 14.1 mc, feeding in a signal at 9670 kc sufficient to produce output and adjusting the variable condenser for minimum output.
- d. New resistor 4.3 ohms added in series with the heater of V-6 6AL5 detector/noise limiter. (to reduce hum).
- e. Location of R-3 changed from lug on S-3 to cinch lug near V-1.

## 1. Errors in the NC-300 Instruction Book

### a. Connections shown in Figure 2, Page 5.

Connections shown connecting remote RF gain control should be such that remote control connects to STDBY and PIN 1 of accessory socket. Drawing is incorrect in that it shows control connected to Pin 8 of the accessory socket. This is B plus.

### b. Page 8 under "AFG" states that the RF gain control is normally set to full on for phone operation, page 9 under Phone Reception indicates that the RF gain control must be run full on to obtain proper AVC action. This is contradictory with page 11 under Measurement of Signal Strength where reduction of the RF gain is advised to bring the reading on the S meter to S-1. Page 11 is correct since the amount of reduction made to have the meter read S-1 is small enough to have no effect on the AVC action.

### c. Page 14 indicates pin voltages. V-11 the OB2 should have pins 1 and 5 with 107 volts and pins 2,3,4,6 and 7 zero volts.

### d. On page 23 the schematic indicates grounding of condenser C-15 in T-3.

This is incorrect. The condenser connects from terminal B to terminal C. Terminal D is grounded. There is no connection made to the shield can inside the transformer as indicated on the diagram.

### e. On the schematic diagram the crystal filter switch S-4 shows C-17 on

Position 1. Position 1 and 2 are reversed on this side of the switch. C-17 should be on position 2 and 1 should be open.

## 2. Changes made after books were printed but prior to production.

### a. Coil - T-28 has tapped winding instead of separate primary. (30-35 mc range for converters).

### b. Resistor R-45, 2200 ohms changed to 3300 ohms. <sup>OK</sup>

### c. A new condenser and coil were added to the mixer partition to form an image trap on the 14 mc band to raise the image ratio from 60 db to 80 db. This trap is adjusted by tuning the receiver to 14.1 mc, feeding in a signal at 9670 kc sufficient to produce output and adjusting the variable condenser for minimum output.

### d. New resistor 4.3 ohms added in series with the heater of V-6 6AL5 detector/noise limiter. (to reduce hum).

### e. Location of R-3 changed from lug on S-3 to cinch lug near V-1.

3. Changes made during production (applies to all sets shipped after October 25, 1955)

- a. Resistor R-1 removed from AVC feed and connected from junction of C-3 and R-2 to ground. Additional resistor added, 4.7 megohms 1/2 watt 10% connected from AVC feed (where R-1 was) to junction of C-3 and R-2. This change puts divided AVC voltage on the RF tube and improves the signal-to-noise ratio on AM and SSB signals. This has no effect on CW. Strong local signals could cause overload which could be taken care of by reducing the gain with the panel RF gain control.
- b. Resistor R-30 has been changed to 27,000 ohms 1/2 watt 10% to decrease the S meter sensitivity. This change was necessitated by change "a" which reduced the AVC action on the RF stage.
- c. Yellow lead connecting between switch S5C and Pin 5 of V-6 has been replaced with a 10,000 ohm resistor. This gives cleaner beat note on CW. The coil L-13 should be resonated after this change is made by tuning in a steady signal with the receiver in the AM position, in the #3 IF selectivity position, for maximum S meter reading and adjusting the slug in the bottom of L-13 for maximum.
- d. Condenser C-46 changed to 2700 mmfd mica, 5% to obtain smoother 3.5 kc bandwidth position. Effect not noticeable therefore not recommended in field.

# SERVICE NOTES

*tuned to tomorrow*

# National

NATIONAL COMPANY, INC., 61 SHERMAN ST., MALDEN 48, MASS. • PHONE MA 2-7950 • CABLE "NATCO" BOSTON

Service Bulletin FSN-30

To: Service Agencies,  
Receiver Distributors,  
Receiver Reps and  
NC-300 Owners

November 15, 1955

Subject: NC-300 Changes

The attached bulletin should be self explanatory; however, a few words of additional explanation may forestall some confusion.

Paragraph 1 indicates errors in the NC-300 instruction book as it was first printed.

Paragraph 2 indicates changes made in the NC-300 after the instruction books had been printed but before production had started.

Paragraph 3 indicates changes that were made after production had started. All receivers shipped after October 25, 1955 have had these changes made at the factory.

Regards,

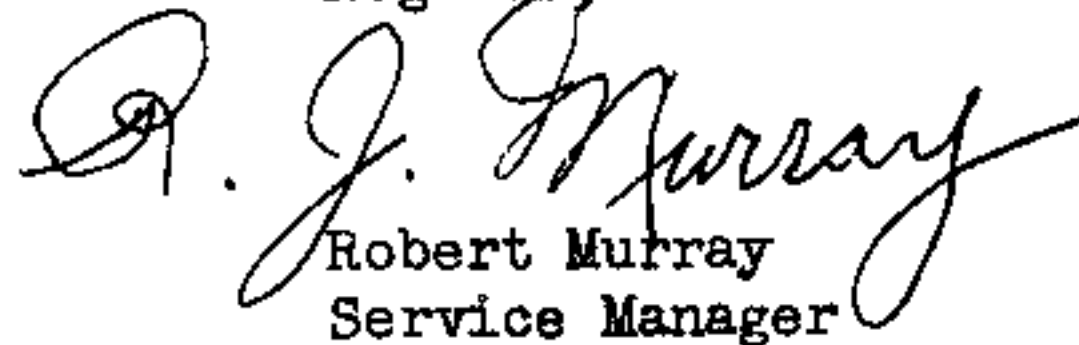
  
Robert Murray  
Service Manager



# SERVICE NOTES

*tuned to tomorrow*

# National

NATIONAL COMPANY, INC., 37 WASHINGTON ST., MELROSE, MASS. • TEL. ME 4-4800 • CABLE "NATCO" BOSTON

Bulletin Number FSN-31

March 8, 1956

To: All Service Agencies  
Receiver Representatives  
Receiver Distributors

Subject: 4H4C - HR0-60 and NC-300

Due to the variation in characteristics and the resultant unreliability of the 4H4C current regulator tube in the NC-300 and the HR0-60, an engineering change notice has been recently issued internally to provide a 2.2 ohm resistor in series with the heater string of the 6AH6 of the NC-300 and the 6C4, 6BE6 string of the HR0-60.

1. NC-300 -- the transformer lead normally on Pin #7 of the 4H4C is placed on Pin #3 and the 2.2 ohm resistor is routed from contact #3 to #7.
2. HR0-60 -- blue tracer normally found on contact #2 of 4H4C socket is wired to contact #6 and 2.2 ohm resistor is wired from contact #6 to #2.

This Service Bulletin supersedes Service Bulletin #12.

Regards,

  
Robert J. Murray, W1FSN  
Service Manager

RJM/s

vlh/1-14-57

**SERVICE  
NOTES**

*tuned to tomorrow*

**National** 

NATIONAL COMPANY, INC., 61 SHERMAN ST., MALDEN 48, MASS. • PHONE MA 2-7950 • CABLE "NATCO" BOSTON

Service Bulletin FSN-32

To: All Distributors, Service  
Agencies and Representatives

From: Robert J. Murray

November 18, 1955

SUBJECT: Replacement 4H4C Ballast Tubes Used in the HRO-60 and NC-300

It has been called to our attention that some difficulty is being experienced in the field obtaining replacement 4H4C ballast tubes as used in the NC-300 and the HRO-60.

We wish to advise that these current regulator tubes are carried by our Service Department and are net to you at \$1.80. Suggested retail price \$2.75.

In the event that a replacement 4H4C tube is not immediately available, your customer can use his receiver temporarily by merely plugging a 6V6 type tube in the 4H4C socket until the proper replacement is received.

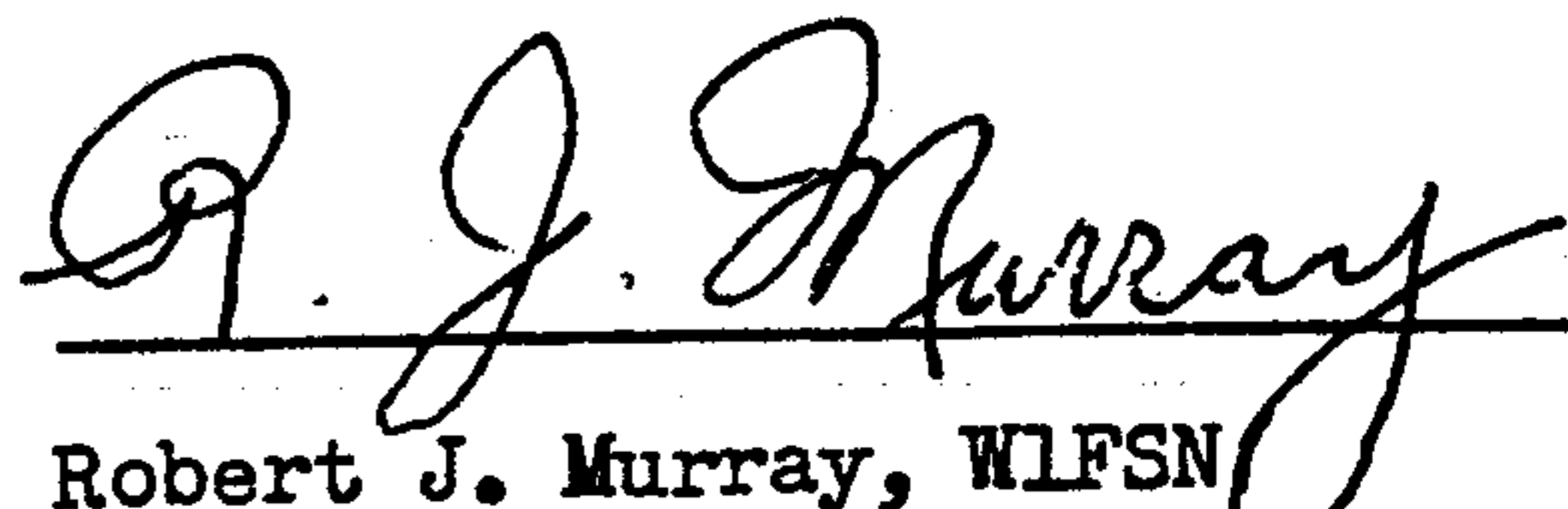
  
Robert J. Murray, WLFSN  
Service Manager

RJM/s



# SERVICE NOTES

*tuned to tomorrow*

# National

NATIONAL COMPANY, INC., 37 WASHINGTON ST., MELROSE, MASS. • TEL. ME 4-4800 • CABLE "NATCO" BOSTON

Bulletin Number FSN-33

To: All Service Agencies

January 26, 1956

Through a clerical error in transmittal of information from our Engineering Test Section to our Production Test Section, certain NC-300 receivers were allowed to pass through test with:

1. Unsatisfactory attenuation of spurious responses 40 kc. ( $\frac{1}{2}$  the 80 kc. I.F.) removed from a strong signal's frequency.
2. Crystal filter improperly aligned for satisfactory bandwidth in the three crystal positions.

This bulletin will be separated into two parts:

1. Dealing with the spurious responses.
2. Dealing with the alignment of the crystal filter.

Regards,

*R. J. Murray*  
R. J. Murray  
Service Manager

RJM:s  
attachments

PART I.

When measuring the magnitude of the spurious response, it is necessary that the antenna trimmer and the phasing capacitor be set to the true signal frequency and not to the spurious frequency.

A considerable improvement in the response of the NC-300 receiver to this spurious frequency can be effected by the following modifications:

A shielded lead should be constructed as shown below:

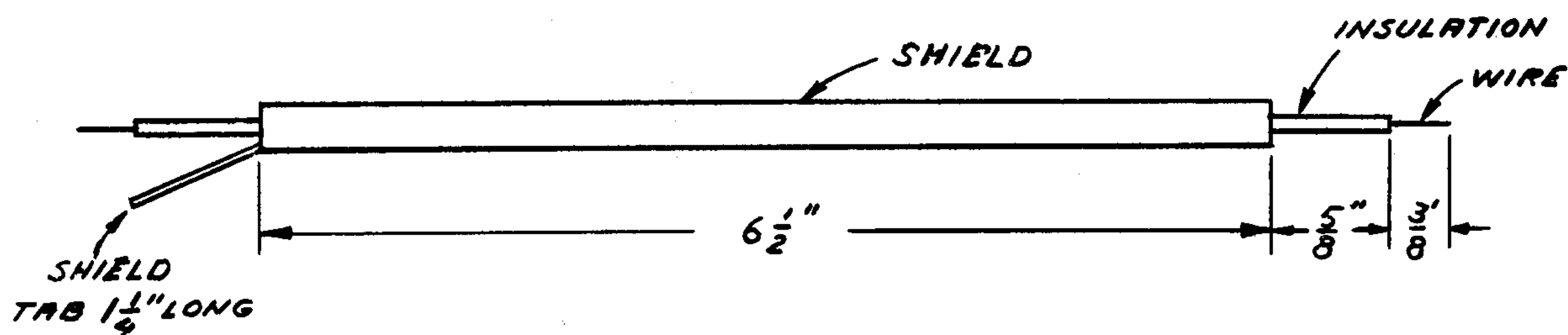

- A. Replace shielded lead from L4 to grid of second converter, V3 with above lead, placing it under phasing control shaft as shown in the pictorial diagram below.

BOTTOM VIEW

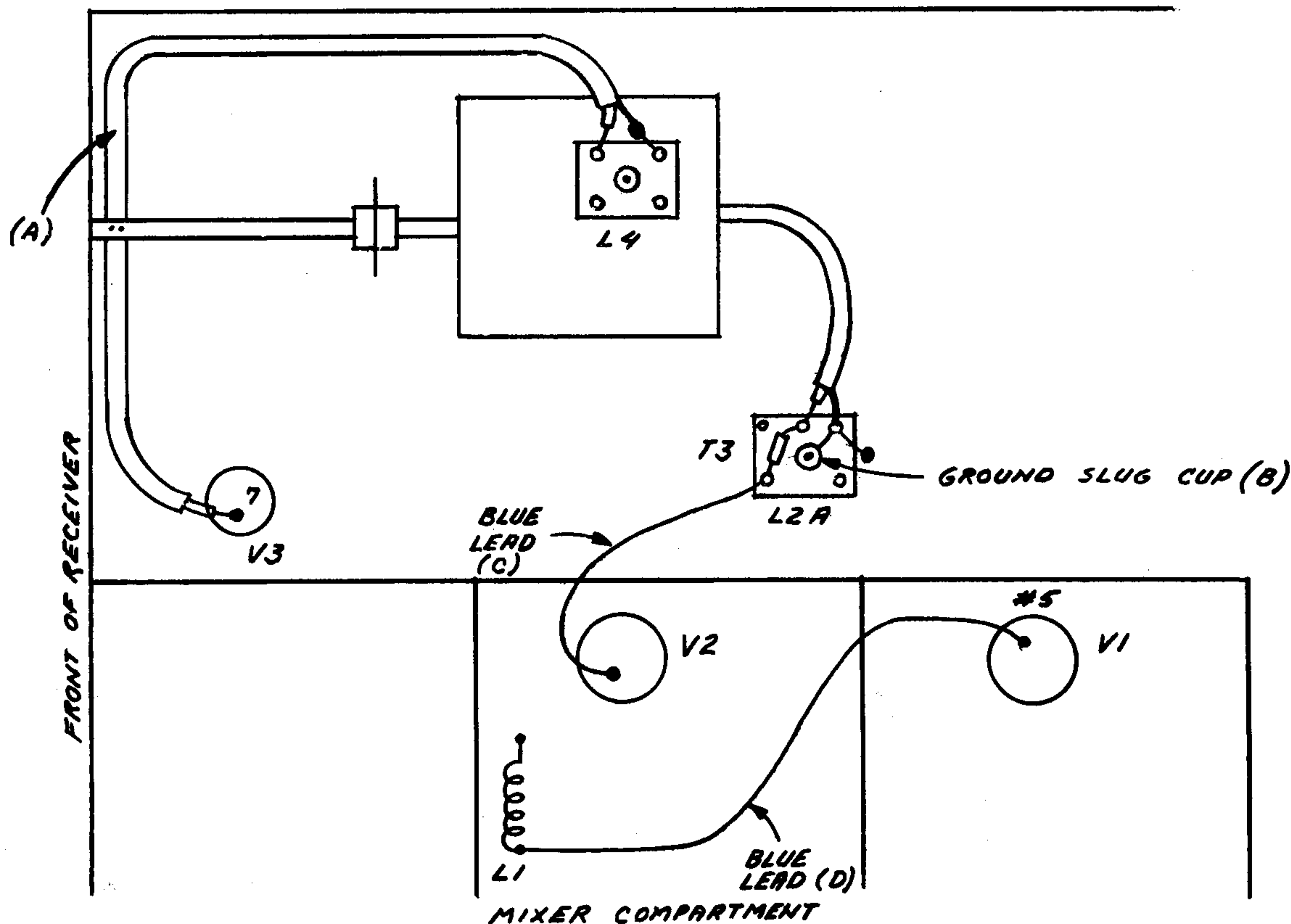



## PART I. (Continued)

- B. Ground the slug cup of T3, as shown, with a short piece of bus wire.
- C. Push blue lead from T3 to first mixer, V2 (6BA7), against the chassis for its entire length.
- D. Push blue lead from the plate of the R. F. amplifier, tube V1, to choke L1 down against the chassis for its entire length.
- E. Repeak eight trimmer capacitors (all in a row) in the mixer compartment for maximum background noise in the middle of each range.
- F. Recheck alignment of L2A and L4. With receiver on AM and Phasing Control peaked, select at off and I.F. at #2. Trim the slug of L2A for maximum background noise.

(The adjustment of L4 will have to be made when adjusting crystal filter for optimum performance.)

## PART II.

This procedure provides for the proper alignment of the crystal filter as used in the NC-300.

- A. Mode switch at AM, I. F., on #1 position (broad); select control on #1 position (broad); turn up R. F. gain until background noise is heard.
- B. Antenna trimmer at maximum noise position; phasing at center.
- C. Adjust slug of L4 until background noise assumes the maximum amount of high-pitched hiss characteristic, indicating maximum broadness due to the passing of the higher pitched sideband frequencies. Turning the slug out from this position will result in a not-so-rapid loss of gain, but the hiss will disappear. The slug should be set at the point of maximum hiss.
- D. Turning select control from one to two to three should indicate increasing selectivity by progressive reduction in high pitched background noise.

PART II. (Continued)

- E. With Phasing Control set at center, turn select control to "off", and I. F. control to position #2 (medium).
- F. Adjust capacitor C16 on top of crystal filter for maximum noise.
- G. To check, turn mode switch to CW and rock CWO control to find center of I. F. pass band.
- H. Turn select control to position #3 (sharp), and again find center of pass band by rocking CWO; this should be very close to that of G. above. If it is not, a slight adjustment of the second conversion oscillator will be necessary until this condition does occur.

Regards,

*R. J. Murray*  
R. J. Murray  
Service Manager

RJM:s

# SERVICE NOTES

tuned to tomorrow

# National

NATIONAL COMPANY, INC., 37 WASHINGTON ST., MELROSE, MASS. • TEL. ME 4-4800 • CABLE "NATCO" BOSTON

Bulletin Number FSN-34

January 26, 1956

**TO:** Service Agencies  
Receiver Representatives

**SUBJECT:** NC-300 C6 Changes

The following changes are recommended in the 6-meter converter to reduce cross-modulation:

Change cathode resistor in 6AK5 2nd R.F. amplifier stage from 470 ohms  $\frac{1}{2}$  watt to 2200 ohms  $\frac{1}{2}$  watt

A 100,000 ohm  $\frac{1}{2}$  watt resistor should be connected between Pin #6 and Pin #2 - 7 of the same 6AK5 2nd R.F. stage

Revised circuit below:

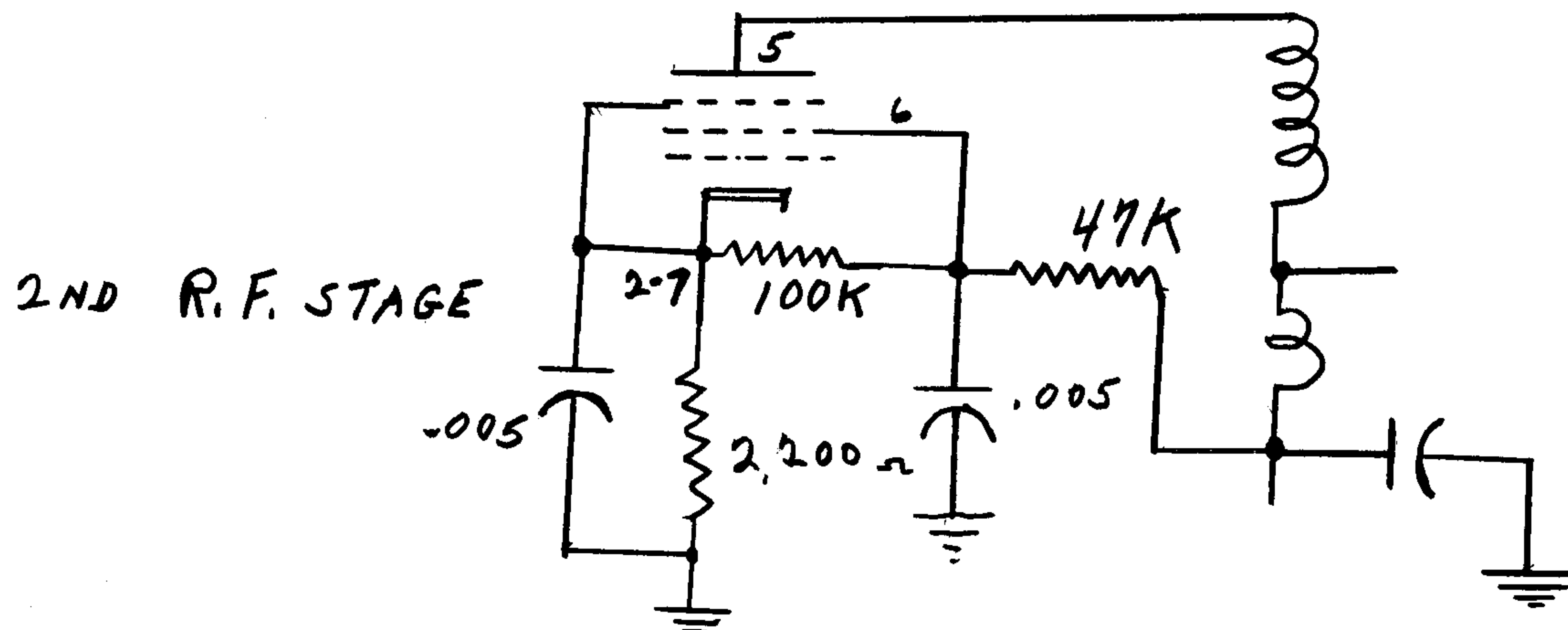

Regards,

*Robert J. Murray*  
R. J. Murray, W1FSN  
Service Manager

vlh/1-14-57



# SERVICE NOTES

tuned to tomorrow

# National

NATIONAL COMPANY, INC., 61 SHERMAN ST., MALDEN 48, MASS. • PHONE MA 2-7950 • CABLE "NATCO" BOSTON

Bulletin Number FSN-35

To: Service Agencies  
and  
Receiver Reps

February 17, 1956

Subject: "S" Meter - NC-300

Some users of the NC-300 have complained about the fact that the "S" meter on the NC-300 seemed too sensitive. This may be adjusted in two ways to satisfy the individual user.

1. To decrease sensitivity of the "S" meter by a fixed amount, decrease the value of R-30 (68K 1/2 watt).
2. To decrease or increase the sensitivity of the "S" meter by a variable amount, replace R-43 (33K 1/2 watt) and R-30 (68K 1/2 watt) with 100 K potentiometer, connect arm of potentiometer to R-55 (47-0K 1/2 watt).

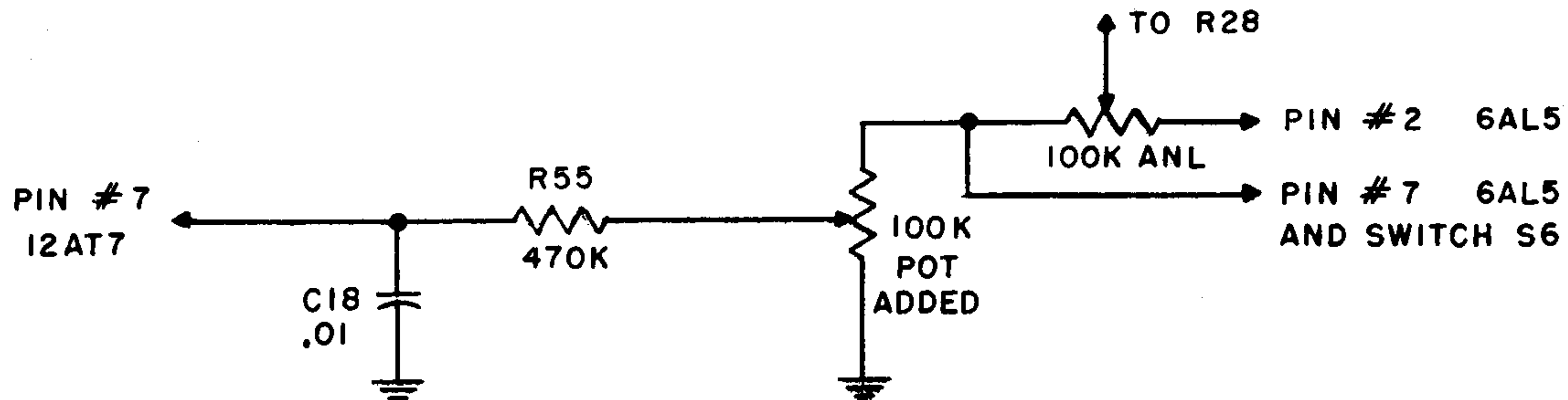

Regards,

*R. J. Murray*  
R. J. Murray  
Service Manager

RJM/mp

# SERVICE NOTES

tuned to tomorrow

# National

NATIONAL COMPANY, INC., 37 WASHINGTON ST., MELROSE, MASS. • TEL. ME 4-4800 • CABLE "NATCO" BOSTON

Bulletin Number FSN-36

March 28, 1956

To: All Service Agencies  
Receiver Representatives  
Receiver Distributors

Subject: Additional Notes on Reduction of Spurious Responses  
and B.C.I. in NC-300 Receivers

1. One shielded cable should be substituted for the blue lead connecting the plate of the first mixer (V2 Pin No. 9) to T3 (B). Drawing of cable below. The vinyl tubing is used to prevent grounds to other sections of the circuitry. Shield tab can be connected to the slug cup of L2-A which should already be grounded in accordance with FSN-33. It may be necessary to repeak L2-A after installation of this shielded lead.

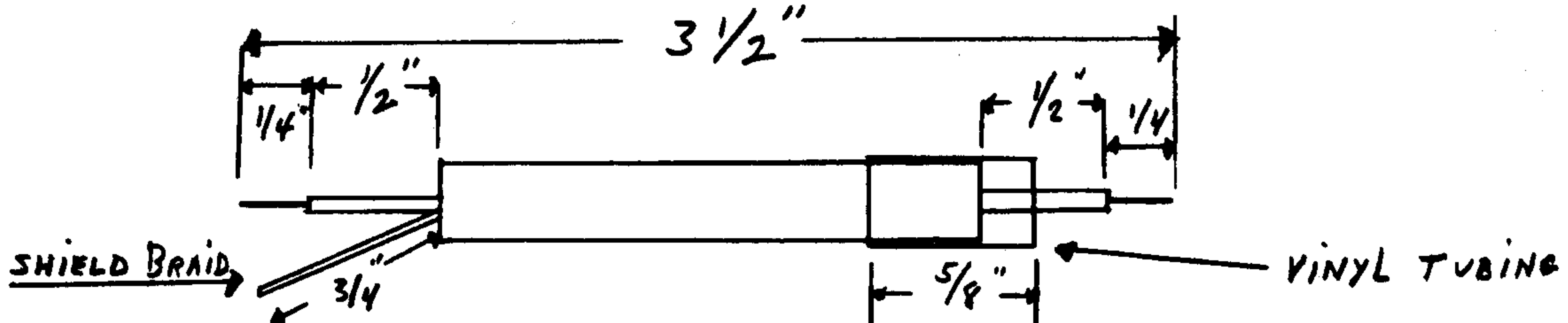

2. Receivers with the prefix 460 preceding the serial number will have new first mixer signal input coils. These coils differ from the original coils in that the 160 meter coil has one turn on the primary, and the 80 meter coil has three turns on the primary.

3. In individual instances where the operator is using unbalanced feed (coaxial cable), the input circuit can be revised by reducing the number of turns on the primary of the antenna input coils. The number of turns remaining on the various primary coils after revision is as follows:

160 meters	4 turns
80 meters	3 turns
all others	2 turns

Extreme caution is required when revising these coils as the fine wire involved is easily broken.

Regards,

*Robert J. Murray*  
Robert J. Murray, WLFSN  
Service Manager

vlh/9-13-56



# SERVICE NOTES

*tuned to tomorrow*

# National

NATIONAL COMPANY, INC., 37 WASHINGTON ST., MELROSE, MASS. • TEL. ME 4-4800 • CABLE "NATCO" BOSTON

Bulletin Number FSN-37

April 16, 1956

**TO:** Service Agencies  
Receiver Representatives  
Receiver Distributors

**Subject:** Final Notes on NC-300

The information contained in this bulletin is intended to supplement previously furnished information and should, when properly applied, result in the finest performing amateur receiver on the market today.

1. Service Bulletin FSN-31 should indicate that the 2.2 ohm resistor referred to is a 1-watt wire-wound type.
2. Service Bulletin FSN-33 and FSN-36 should indicate that the shielded cable to be used is a good grade of polyethylene type insulated coax such as RG 58 U or equivalent. We are using Turbo 2101 Microphone cable which is somewhat smaller in diameter but has excellent characteristics.
3. C13 which is normally a 1 uufd capacitor (our part number D825-D 470) should be changed to a  $\frac{1}{2}$  uufd capacitor (our part number CCC 20UKOR5C). It is permissible to use two 1 uufd capacitors in series, provided the leads are kept short.

73,

  
Robert J. Murray, W1FSN  
Service Manager

RJM:s  
mp  
vlh/1-14-57



# SERVICE NOTES

tuned to tomorrow

# National

NATIONAL COMPANY, INC., 37 WASHINGTON ST., MELROSE, MASS. • TEL. ME 4-4800 • CABLE "NATCO" BOSTON

Bulletin Number FSN-38

To: Service Agencies  
Receiver Reps  
Receiver Distributors

July 25, 1956

Subject: TV Picture Information Interference on Hi-Fi Frequency Bands of NC-300

In certain metropolitan areas, I.T.V. is experienced on the 21 mc, 28 mc and X bands of the NC-300. This can be minimized by proper selection of antenna and the use of a low pass filter shown in the diagram below. This filter should be inserted in series with the antenna and located as close as practicable to the antenna terminals on the back of the chassis. A good earth ground helps considerably.

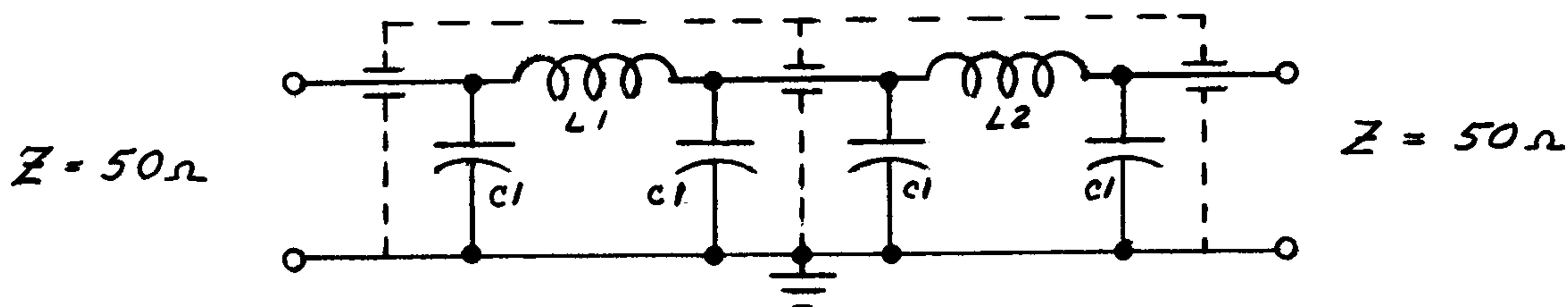

L1 = .4 uh      10 Turns #20 on 3/8" form spaced 1/2"  
L2 = .4 uh  
C1 = 80 uuf Ceramic

Regards,

*R. J. Murray*  
R. J. Murray  
Service Manager

RJM/mp

# SERVICE NOTES

*tuned to tomorrow*

# National

NATIONAL COMPANY, INC., 37 WASHINGTON ST., MELROSE, MASS. • TEL. ME 4-4800 • CABLE "NATCO" BOSTON

Bulletin Number FSN-39

July 30, 1956

To: All Service Agencies  
Receiver Representatives  
Receiver Distributors

Subject: Reception of WWV on NC-300

WWV at 10 mcs. may be received on the NC-300 by connecting a 330 uuf silver mica capacitor from the stator of the high-frequency oscillator section of the main tuning capacitor to chassis ground. Set the front panel antenna trimmer to minimum capacity and look for WWV on the 7 mc. band. Just where it comes in will be determined by the capacitance tolerance of the capacitor.

I suggest that the capacitor be equipped with pee-wee clips so that it can be quickly connected and disconnected.

73,

NATIONAL COMPANY, INC.

  
Robert J. Murray, W1FSN  
Service Manager

RJM/vlh  
10-25-56



**SERVICE  
NOTES**

*tuned to tomorrow*

**National** 

NATIONAL COMPANY, INC., 37 WASHINGTON ST., MELROSE, MASS. • TEL. ME 4-4800 • CABLE "NATCO" BOSTON

Bulletin Number FSN-41

November 23, 1956

To: All Service Agencies  
Receiver Representatives

Subject: 4H4C Ballast HRO-60 NC-300

In instances where the 4H4C current regulator tube repeatedly fails, our Engineering Department recommends that the customer discard the 4H4C altogether and replace it with a 6V6GT previously recommended as a temporary substitute.

The additional drift caused by this substitution will not exceed 250 to 300 cycles at 29 megacycles, which is negligible.

Regards,

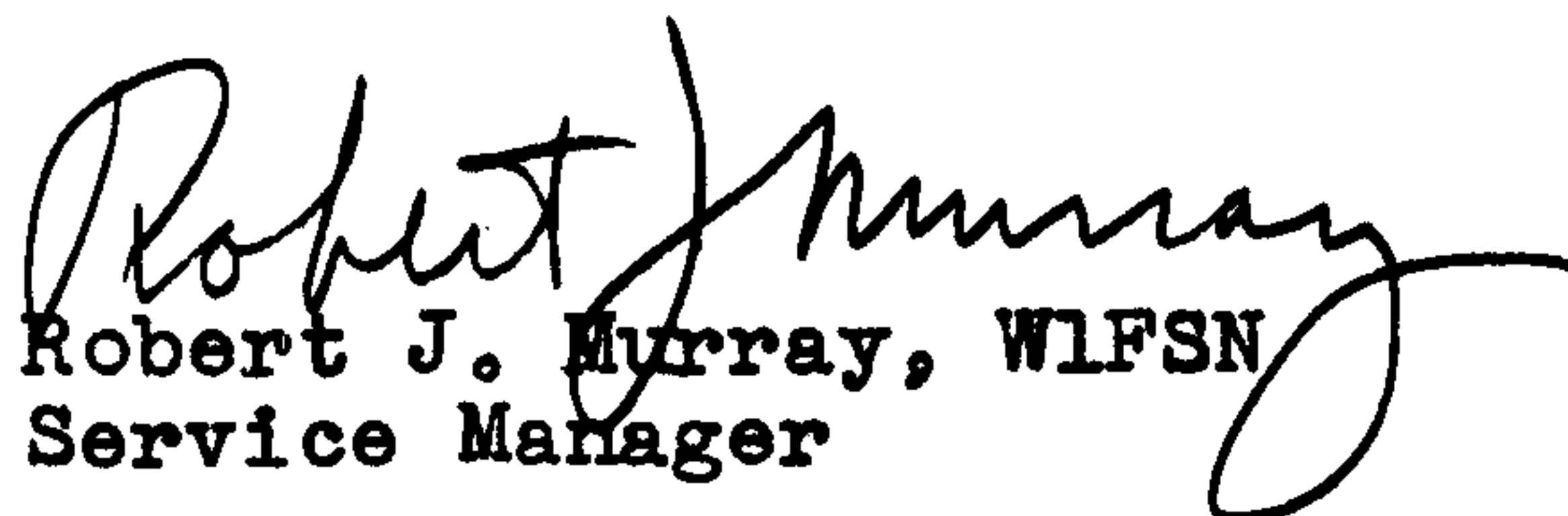
  
Robert J. Murray, WLFSN  
Service Manager

RJM/vlh



# SERVICE NOTES

*tuned to tomorrow*

# National

NATIONAL COMPANY, INC., 37 WASHINGTON ST., MELROSE, MASS. • TEL. ME 4-4800 • CABLE "NATCO" BOSTON

Bulletin Number FSN-48

August 4, 1958

TO: ALL Service Agencies  
Receiver Representatives

SUBJECT: Calibration and Crystal Filter NC-300

This time of year with relatively high heat and humidity usually brings sporadic reports of calibration errors and ineffective crystal filter action in the NC-300. This is due to the second conversion oscillator coil having drifted off its correct frequency of 2295 kc.

In most instances all that is necessary is that L6 in T5 be trimmed to the correct frequency by means of the slug in it. There are other rare cases where the second conversion oscillator will not maintain its frequency for more than a period of a month or so. These reports usually originate in areas of high humidity such as Florida and Louisiana and other localized areas.

In these instances we recommend crystal control of the second conversion oscillator as per the attached schematic. It should be remembered that there are now two crystals in the circuit which must be properly coordinated if the receiver is to work at maximum efficiency. Normal production tolerances in the grinding of the crystals may allow a situation to exist where the difference in frequency of the crystal in the crystal filter (2215 kc) and the crystal in the second conversion oscillator (2295 kc) is not exactly 80 kc (second IF).

If this is so the second IF strip must be adjusted accordingly either slightly higher or slightly lower to compensate.

73,

NATIONAL COMPANY, INC.

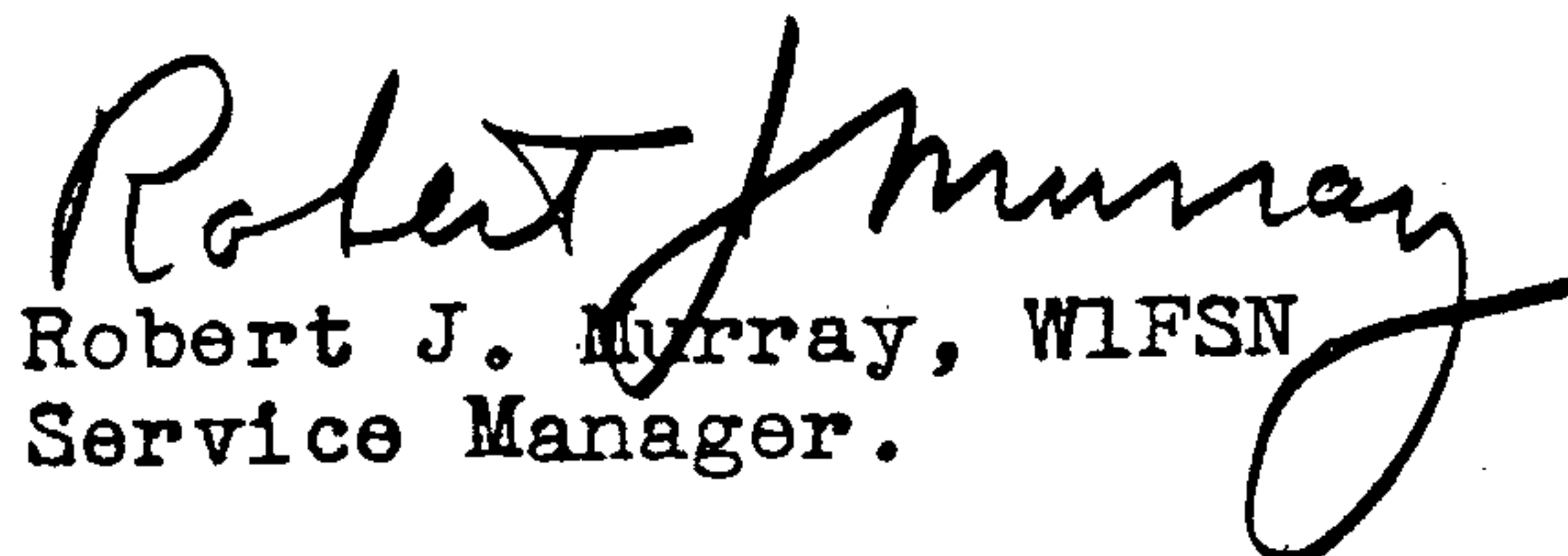
  
Robert J. Murray, WIFSN  
Service Manager.

RJM:rh

August 4, 1958

- NOTE -

1. RESISTORS 1/2 WATT
2. CAPACITANCE IN  $\mu\text{F}$  UNLESS OTHERWISE SPECIFIED

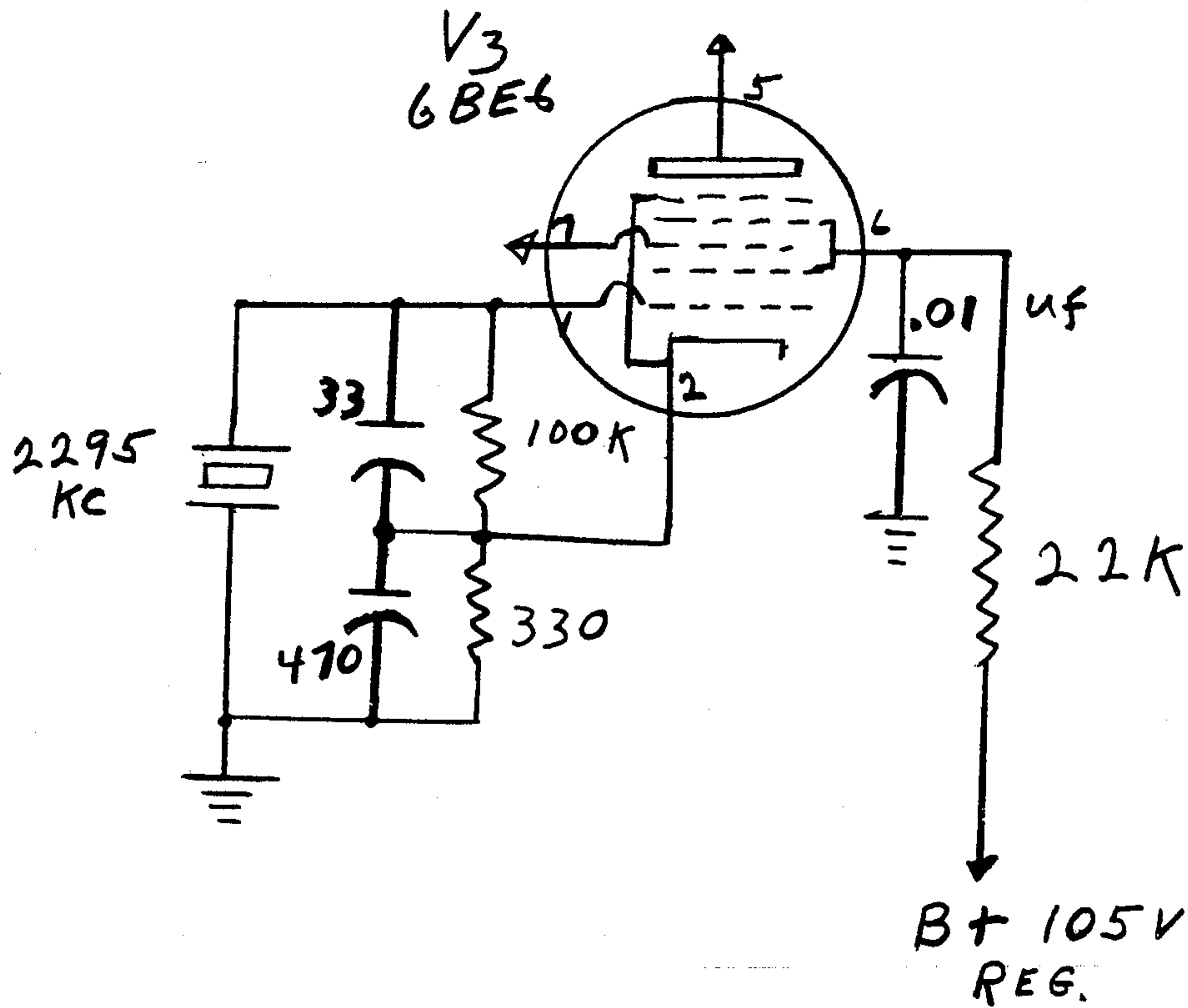

R.J.M.  
8-4-58