

The **NATIONAL**
NC 400
COMMUNICATIONS RECEIVER

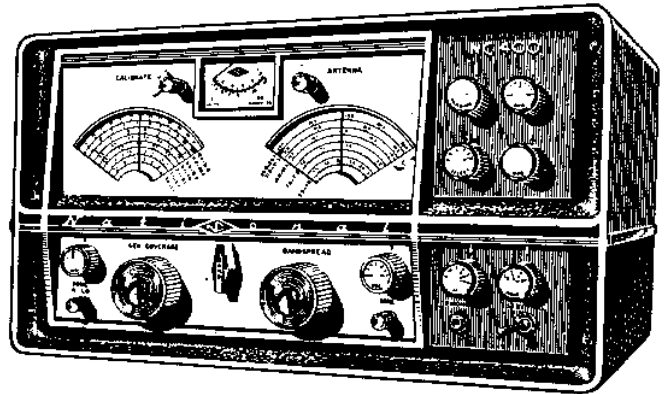

NATIONAL RADIO COMPANY, INC.

INSTRUCTION MANUAL

for the

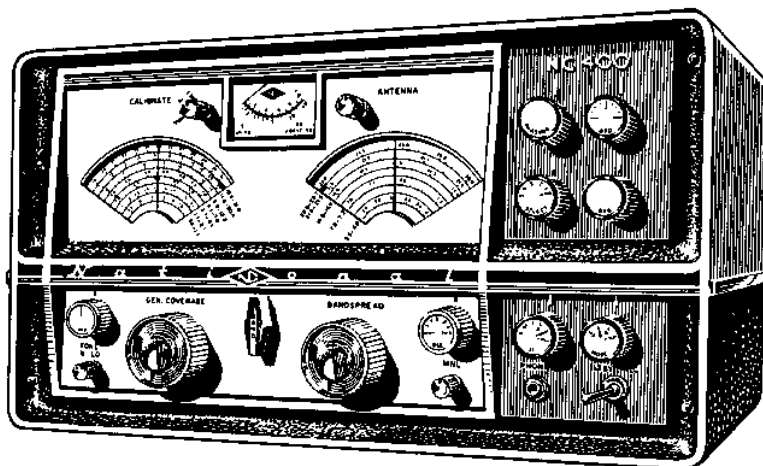

NATIONAL NC-400 COMMUNICATIONS RECEIVER

SECTION 1. DESCRIPTION

1.1 GENERAL

The National Radio Company Model NC-400 is a dual-conversion communications receiver with 18 tubes including rectifier and voltage regulator for the reception of CW, conventional AM, and single-sideband signals. The frequency range of 540 kc to 31 mc is covered in seven bands, and an extreme IF selectivity range from 16 kc to 150 cycles is provided. The bandspread tuning scale is calibrated for the 80, 40, 20, 15 and 10 meter amateur bands.

The receiver is housed in a two-tone metal cabinet of modern functional design. All operating controls and indicators are on the front panel, with test jacks and terminals on the rear chassis panel.

Sensitivity is approximately 1 uv for a 10 db signal-to-noise ratio, and signal circuits are designed to obtain a constant stage gain when tuned through a band or switched from one band to another. Frequency stability is 0.002 percent long-term drift after warm-up. All early tuned circuits are designed to minimize cross-modulation and the generation of spurious frequencies due to overload effects.

1.1.1 Special Features

Single-Sideband Provisions. A pentagrid converter is used as a heterodyne detector with a separate beat oscillator. The beat oscillator may be crystal-controlled if desired. Sideband selection (on standard receivers) is provided by 14 tuned circuits in the second IF section. The center frequency is shifted by a panel selector switch for reception of one sideband or the other.

Fixed-Channel Operation. The HF oscillator is provided with five crystal sockets which may be used for fixed-channel operation of the receiver. Crystal-controlled channels are selected by a front-panel switch. In addition, the HF oscillator may be controlled from an external master oscillator also selected by the front-panel switch. A CALIBRATE-tune switch permits the use of the S-meter to tune the receiver to crystal or external oscillator frequency in the absence of a signal.

Diversity Provisions. A special Diversity Modification Kit is available. It provides external control of all oscillators (HF oscillator, second conversion oscillator, and beat-frequency oscillator). With diversity

modifications, rear-panel selection at the receiver makes possible the use of the receiver either as a master receiver or as a slave receiver fed from external oscillator sources. All NC-400 oscillators are designed so that neither auxiliary amplifiers nor special circuits are required for adequate mixer drive when the receiver is diversity-modified. Required external excitation is approximately 0.5 volt (rms).

Detector output, AGC, and IF signal information are available at the rear-panel connectors. The IF output level is 0.01 volts.

Plug-in Units. A plug-in crystal calibrator unit is available to provide crystal-controlled marker frequencies at 100 kc and 1 mc intervals.

The crystal filter in the receiver IF section is plugged in and may be removed for the substitution of a mechanical filter housing which will accept three commercial-type mechanical filters. Panel control of filter selectivity is provided.

1.2 CIRCUIT DESCRIPTION

The NC-400 has two RF amplifier stages with three tuned circuits at the signal frequency. Dual mixers are used for the first conversion stage, one converting to 455 kc for single conversion on the four lower bands, the other to 1,270 kc for double conversion on the three highest bands. The second converter is crystal controlled and converts from 1,720 kc to 455 kc. The high-frequency oscillator circuit may be tuned manually or may be crystal-controlled for fixed-channel operation or may be driven by an external oscillator.

The first IF section has two tuned circuits at 1,720 kc. The second IF section uses three tubes and six tuned circuits at 455 kc for 16 kc, 8 kc, and 4 kc bandwidths: 14 tuned circuits for 3.5 kc bandwidth and single-sideband selection and 10 tuned circuits plus a crystal filter for bandwidths to 150 cycles.

Separate detector, noise limiter and AGC circuits are provided for optimum reception of either AM signals or CW and SSB signals. A heterodyne detector with a pentagrid converter is used for CW or SSB reception, a separate beat oscillator stage providing optimum stability and constant injection level. The beat oscillator may be crystal-controlled by the insertion of a suitable crystal into the socket provided.

A two-stage audio amplifier operates headphones or a speaker and provides a 3.2-ohm unbalanced output and a 600-ohm balanced output. The power supply is integral with the receiver and includes both filament and plate regulation for the HF oscillator.

A functional block diagram of the NC-400 is shown in Figure 1. It relates to the description of the major receiver sections to follow.

1.2.1 RF Amplifier

The two-stage RF amplifier with three tuned circuits is used on all bands. The four-section tuning capacitor has the general coverage and band-spread tuning sections on separate frames. Nilvar plates and high-quality ceramic coil forms contribute to the exceptional frequency stability of the NC-400. Trimmers, padders and other circuit capacitances are carefully selected for zero temperature coefficient or required negative compensation. AGC is applied to both RF amplifier stages as well as to the three IF amplifier stages.

A band-switch section in the cathode circuits of the RF amplifiers selects the proper cathode resistor for these stages to maintain a constant gain on all bands. The manual RF Gain control is in the cathode circuit of the second RF amplifier and two of the IF amplifiers. The receiver frequency range of 540 kc to 31 mc is covered in 7 bands: therefore, each band covers a frequency range of one octave or less, contributing to constant gain over the band and accurate tracking of tuned circuits.

1.2.2 Conversion

The first conversion stage is a dual mixer with two tubes in parallel. A band-switch section selects the appropriate mixer by opening the cathode circuit on the other mixer. Mixer 1 operates on bands 1, 2, 3 and 4, for single conversion on these bands. Excellent image rejection is obtained with the three tuned circuits in the RF amplifier, and dual conversion is not required. The HF oscillator operates 455 kc above the signal, and the mixer provides a 455-kc signal for the second IF section.

Mixer 2 operates on bands 5, 6 and 7. The HF oscillator is 1,720 kc above the signal frequency, and the mixer provides a 1,720-kc signal for the first IF section. A crystal-controlled converter converts the 1,720-kc signal to 455kc for application to the common second IF section.

The HF oscillator may be crystal-controlled for fixed-channel receiver operation when suitable crystals are plugged into the five sockets provided. Panel switches select channels and an S-meter tuning circuit so that the receiver may be tuned to channel frequency in the absence of a signal. An external oscillator may be substituted for the HF oscillator, by using the connector on the chassis rear panel.

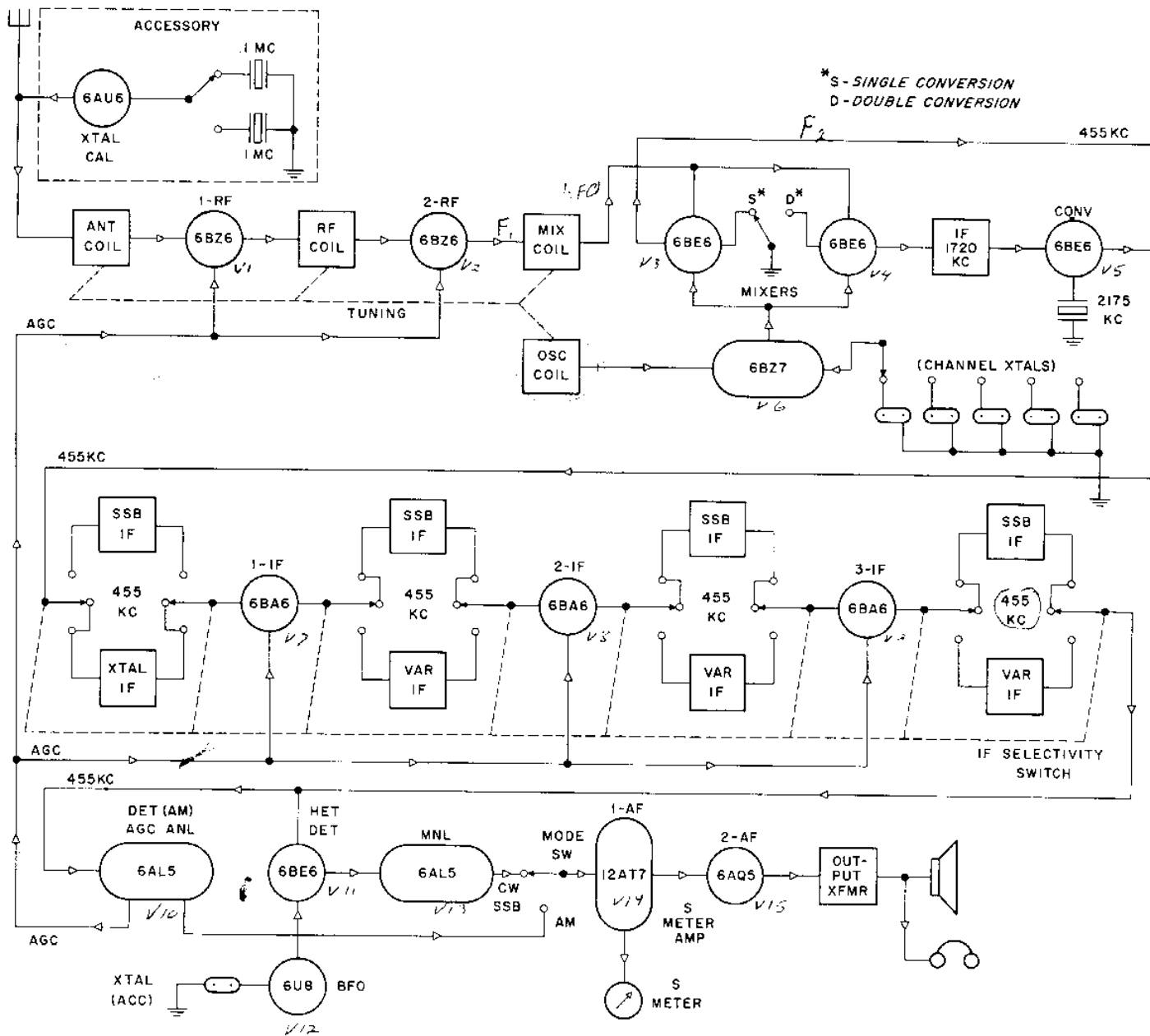

Figure 1. Block Diagram NC-400

1.2.3. IF Amplification

The 1st IF section uses two tuned circuits at 1,720 kc. It is not in operation on the four lowest bands.

The 2nd IF section is essentially a dual IF channel. Although both complete channels are not operated simultaneously, appropriate sections are selected by the IF selector switch to provide the extreme selectivity range offered by the NC-400. The top channel consists of 14 tuned circuits with a resultant bandwidth of 3.5 kc (at 6 db) and is used for SSB reception. The IF selector switch provides for selection of either sideband by switching the center frequency of the 14 tuned circuits. Selected fixed capacitors are added or removed from the tuned circuits to shift tuning from one sideband to the other. The positions marked SB1 and SB2 indicate the sideband selected.

The VS (very sharp) position of the IF selector switch substitutes the crystal filter of the bottom channel for the first IF transformer of the top channel. Selectivity may be increased from 3.5 kc to 150 cycles through the use of the five-position crystal SELECT switch.

With the IF selector switch in the S(sharp), M(medium) or B(broad) positions, the bottom IF channel is used with the crystal circuit by-passed. Six tuned circuits provide bandwidths of 4 kc, 8 kc and 16kc. The tertiary windings on two of the IF transformers in this section are switched to provide this selection.

AGC is applied to all three IF stages. The first two have a switch section in series with the cathode circuit to maintain constant band-to-band gain by appropriate selection of cathode resistors. The manual RF Gain control is connected to the cathode circuits of the first two IF stages as well as in the 2nd RF amplifier. Figure 2 shows the frequency response of the IF section for all positions of the IF selector switch.

1.2.4 Detection

Individual detector and noise-limiter circuits are provided for reception of AM, or CW and SSB signals. The AM detector is a conventional diode circuit followed by a diode automatic noise limiter. The first position of the MODE switch provides AM detection with the automatic noise limiter; the second position removes the automatic noise limiter from the circuit.

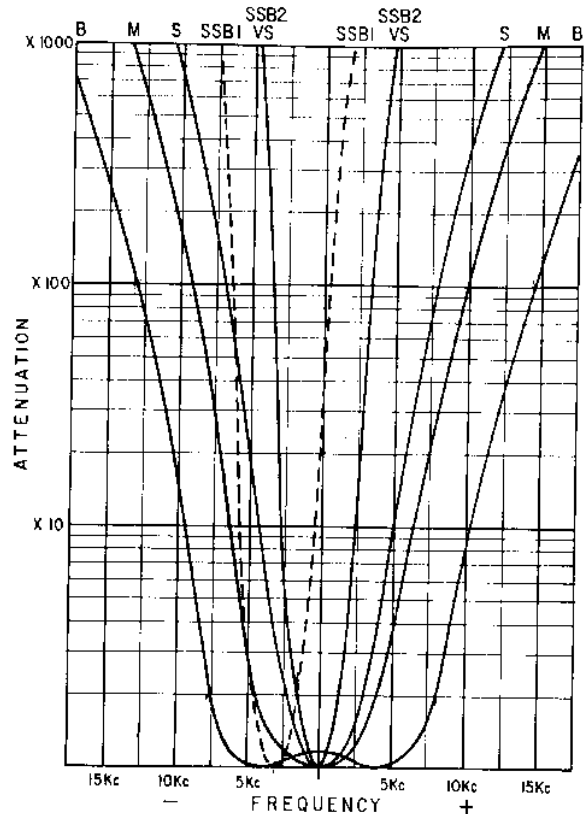

Figure 2. IF Selectivity Curves

For these MODE switch positions the audio amplifier section is connected to the AM detector load circuit and the beat frequency oscillator and heterodyne detector circuits are by-passed. A section of the MODE switch opens the cathode circuit of these stages when receiving AM signals. AGC is supplied by the AM detector circuit and is applied to both RF stages and the three IF stages.

In the SSB position of the MODE switch, the beat frequency oscillator and heterodyne detector are used and the audio amplifier section is connected to the manual noise limiter stage following the heterodyne detector. The AGC circuit from the AM detector is still in operation but is modified for SSB reception as described in Section 1.2.5.

The last position of the MODE switch is for CW reception. The circuit is the same as for SSB reception, but the AGC circuit is grounded. Tone CW (MCW) signals can be received through the use of one of the AM positions.

1.2.5 AGC for SSB Reception

A unique circuit provides fast attack and slow decay of the AGC voltage for reception of SSB signals. The diode detector for AM reception operates continuously in all positions of the MODE switch, and a small dc voltage is applied to the diode circuit providing a small amount of delayed AGC. With the MODE switch in the SSB position, a silicon diode is shunted across the AGC filter resistor. The diode polarity is such as to effectively short the resistor during an SSB audio peak, rapidly increasing the AGC voltage. A comparatively large AGC filter capacitor is quickly charged at this time. The capacitor discharges slowly through the filter resistor due to the opposite polarity of the diode. The resultant AGC voltage rises quickly during SSB audio peaks and decreases slowly, preventing the characteristic audio thump and background noise usually associated with SSB reception.

1.2.6 BFO

A separate beat frequency oscillator provides optimum stability and injection level. A conventional BFO frequency control allows pitch adjustment for reception of CW and SSB signals. A crystal socket is provided for crystal control of the BFO, using a 455-kc crystal.

1.2.7 Audio Amplification

The audio amplifier has two-stages and delivers 1 watt of audio power with less than 10 per cent distortion. Two output transformer windings provide a 3.2-ohm unbalanced, and a 600-ohm balanced output connection. The input audio amplifier is a dual triode, with one section used as the S-meter amplifier. A tone control allows suppression of high noise frequencies. An input connection to the audio section is at the accessory socket on the chassis rear panel. Figure 3 shows the frequency response of the audio amplifier.

1.2.8 S-Meter

The S-meter gives the operator a true indication of relative strength of incoming signals. The meter is calibrated in S units from 0 to 9 and in decibels from S-9 to 40 db over S-9. A potentiometer is provided on the chassis to zero-set the meter.

1.3 ACCESSORIES

Crystal Calibrator (XCU 400). A socket for the Crystal Calibrator unit is provided on the receiver chassis. A panel switch selects 100 kc or 1 mc marker frequencies. Refer to Section 2 for installation and operating instructions.

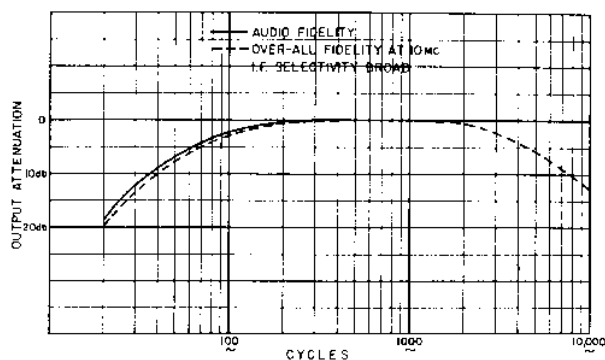

Figure 3. Audio Response

Fixed Channel Operation. Five crystal sockets, permitting crystal control of the HF oscillator, are provided on the receiver chassis. A panel switch selects the crystals for fixed-channel receiver operation. Crystal frequencies are 455 kc above the channel frequency on bands 1, 2, 3 and 4 and 1,720 kc above the signal for bands 5, 6 and 7. The HF oscillator may also be controlled by an external master oscillator selected by a panel switch. An oscillator input jack is provided on the chassis rear panel.

A CALIBRATE-tune switch in the S-meter circuit permits use of the S-meter to tune the receiver to the channel frequencies in the absence of a signal.

Crystal Controlled BFO. For a single-sideband reception the BFO may be crystal-controlled by removing the plug-mounted resistor (P1A) in the BFO circuit and inserting a 455-kc crystal.

Mechanical IF Filter Housing. A commercial-type mechanical filter may be used by removing the plug-in crystal filter and substituting the accessory Mechanical Filter Housing. This housing will accept up to three mechanical filters with bandwidths of 500 cps to 16kc. If desired, matched single-sideband filters may be used in the filter accessory. The Mechanical Filter Housing provides suitable matching circuits and a means of front panel selection of the desired response.

In the panel control OFF position, normal IF responses are obtained.

Diversity Modification. The special Diversity Modification Kit permits internal or external control of all oscillators. The kit includes connectors, rotary switches, switch shaft extensions and a single preamplifier stage. All mounting holes are drilled to permit installation of the added components with a minimum of receiver modification.

When diversity modification is installed, the following additional functions are provided on the chassis rear panel:

1. Intermediate oscillator input/output

2. Beat-frequency oscillator input/output
3. Intermediate oscillator master/slave switch
4. Beat-frequency oscillator master/slave switch
5. High-frequency oscillator master/slave switch

The audio section input circuit and the AGC circuit are available at the accessory socket (P2). Jumpers in the accessory plug (P2A) close these circuits for standard receiver operation.

SECTION 2. INSTALLATION

2.1 UNPACKING

Model NC-400 Communications Receiver is packed and shipped in accordance with best commercial procedures. No special information is required for unpacking, other than use of normal caution. After unpacking, thoroughly check the equipment for damage or defects that may have occurred in transit. Check all tubes and plug-in components to make sure they are properly seated in their sockets.

2.2 PREPARATION FOR USE

The NC-400 is designed for table or rack-mounted operation. For rack mounting, remove the dust cover and outer panel bezel to expose the receiver panel. The panel edges are drilled for standard rack mounting. Place the receiver in a position which permits free access of air for ventilation, for either table or rack mounted operation. Refer to Figure 4 for connector and terminal board information.

2.2.1 Power Supply

The NC-400 may be operated from either a 115 v or 230 v 50/60 cycle power main. Before applying power to the receiver, check the position of switch S7 (115-230 v) on top of the chassis near power transformer (T35 in Figure 6). Place switch S7 in the proper position for the power source to be used.

2.2.2 Antenna

The impedance at the input connector J1 is designed to match a 52-ohm coaxial transmission line. The chassis antenna receptacle mates with an Amphenol UHF series cable-plug, catalogue number 83-1SP

(JAN-PL259). A single wire antenna may be used; connect the lead-in wire to the cable-plug center terminal and a ground lead to the receiver chassis.

Any of the conventional dipole or beam antennas, with a 50 to 70 ohm transmission line, provide an ideal antenna system. An existing antenna with a 300-ohm balanced line may also be used, provided an antenna coupler or balun is employed to match the antenna to the 52-ohm unbalanced input of the NC-400 receiver.

The exceptional sensitivity and signal-to-noise characteristics of the receiver are fully attained only with proper antenna and ground facilities.

NOTE

If the receiver is used in close proximity to the transmitting equipment some provision must be made to short the antenna terminals to ground during transmitting periods to prevent damage to the antenna coils. This is most easily accomplished by means of a relay connected to the antenna terminals and ground. The relay should be located within six inches of the antenna terminal strip to prevent excessive pick-up.

2.2.3 Audio Output

A permanent-magnet dynamic speaker, such as the National type NTS-2 or equivalent, may be connected to the 3.2-ohm terminals of the terminal board TB-2 located on the chassis rear panel. Headphones of the high-impedance type may be plugged into the PHONES jack with a standard plug. The loudspeaker is automatically silenced when the phone plug is inserted.

A 600-ohm terminal is available at TB-2 for receiver operation with a 600-ohm line. The output transformer winding for this impedance is ungrounded for external circuit application.

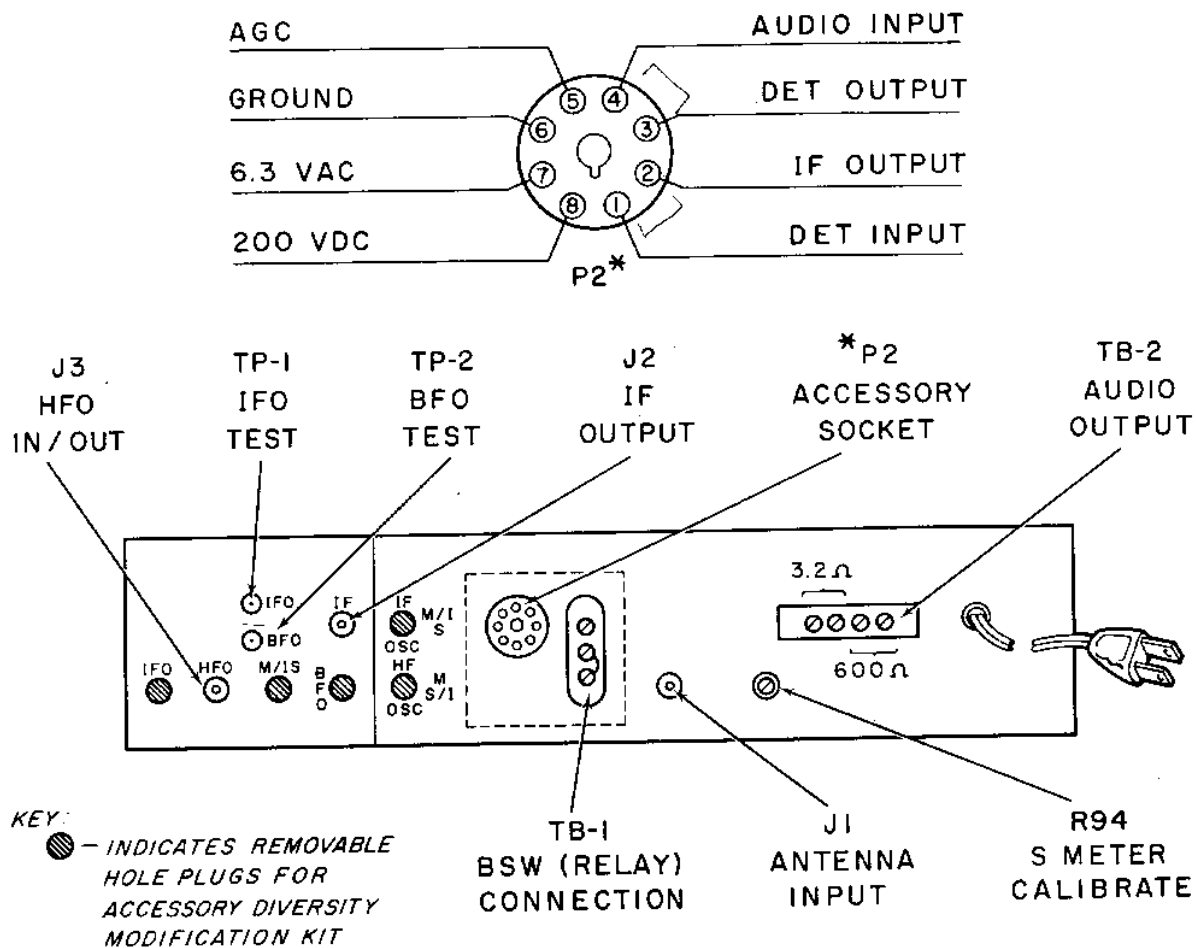

Figure 4. Rear Chassis Panel

2.2.4 Relay Connection

A three terminal connection strip (TB-1) is mounted on the chassis rear panel. These terminals allow external relay control of the receiver's send-receive circuit. The NC-400 is shipped from the factory with a jumper connected between terminals 2 and 3. Relay contacts connected to terminals 1 and 2 will parallel the panel STBY/REC switch (S8) and provide relay control of the switch circuit when placed in the STBY(standby) position. Place panel switch in REC (receive) position to override the external relay.

Removing the jumper and connecting the relay contacts to terminals 2 and 3 inserts the contacts in series with the panel STBY/REC switch. With this connection the panel switch must be in REC position for relay control of the send-receive circuit. Placing the panel switch in STBY position opens the relay circuit.

2.3 ACCESSORIES

The NC-400 is designed to accommodate several accessory units. Chassis sockets are provided for the accessories described in the following paragraphs. The standard receiver includes a crystal filter unit mounted in sockets, which will also accommodate a mechanical filter housing.

2.3.1 Crystal Calibrator

The calibrator socket (P3) is factory wired so that the National XCU-400 Crystal Calibrator unit may be inserted. The CALIBRATE switch (S9), on the receiver panel, selects the choice of marker frequency. Figure 6 shows the location of the calibrator socket on the chassis. Refer to Section 6 for circuit information and operating instructions.

2.3.2 Oscillator Crystal Control

Five crystal sockets for crystal control of the HF Oscillator are located on top of the chassis, as shown in Figure 6. The sockets will accept type HC6/U crystal holders (or equivalent). Refer to Section 3.4 for information regarding the selection of crystal frequencies for the various bands. A panel control permits individual selection of the crystals.

An additional socket (P1) provides for crystal control of the BFO circuit. The location of this socket is indicated in Figure 6. In standard receivers, a plug (P1A) containing a resistor is inserted in this socket at the factory and must be removed when converting to crystal control of the BFO. This socket will accept crystal holders such as the HC6/U (the required crystal frequency is 455 kc).

2.3.3 Mechanical Filter Housing

The standard receiver crystal IF filter is a plug-in unit and is easily removed for replacement by a mechanical-type filter housing. The selectivity and phasing

controls on the crystal filter leave two panel holes when the unit is removed. One hole will receive the selectivity control shaft of the Mechanical Filter Housing and the other is covered with a plug button. Refer to Section 6 for specific installation and operating instructions.

2.3.4 Diversity Modification

The Diversity Modification Kit includes all hardware and components required to make this modification. Major parts and switch sections are partially wired to simplify the circuit changes required. All mounting holes have been drilled in the standard receiver for brackets and connectors. Refer to Section 6 for specific information and installation instructions.

An accessory socket (P2) is available on the chassis rear panel for AGC and audio information required for diversity operation. This socket provides filament and plate power for the operation of miscellaneous equipment, also access to the receiver audio input circuit and detector output circuit.

SECTION 3. OPERATION

3.1 GENERAL

The purpose of this section is to explain the operation of the NC-400 and to help the operator to get maximum performance. The operator should familiarize himself thoroughly with the functions of the various controls. These controls are shown in the front-panel view of the receiver, Figure 5 and are referred to in the text in capital letters.

3.2 CONTROLS

The controls are grouped in the following general categories and will be described in this sequence.

- a. RF section
- b. IF and Detector section
- c. Audio section
- d. Accessory

3.2.1 RF Section Controls

BAND Switch. A positive detent mechanism assures precise selection of coils for each of the seven bands. As the BAND knob is turned, targets are positioned on both the general coverage and the bandspread dials to indicate the band in use.

GENERAL COVERAGE Tuning. The general-coverage dial is rim-driven by the panel GENERAL COVERAGE tuning control. This control drives the tuning condenser through a 5 to 3 reduction gear of antibacklash design. Each band is calibrated in megacycles on the dial, and a 0 to 100 logging scale is included. The general coverage dial is calibrated with red marks at 4.0, 7.3, 14.4, 21.5 and 29.7 mc. When the general coverage dial is set to these calibrations the appropriate range will be properly calibrated.

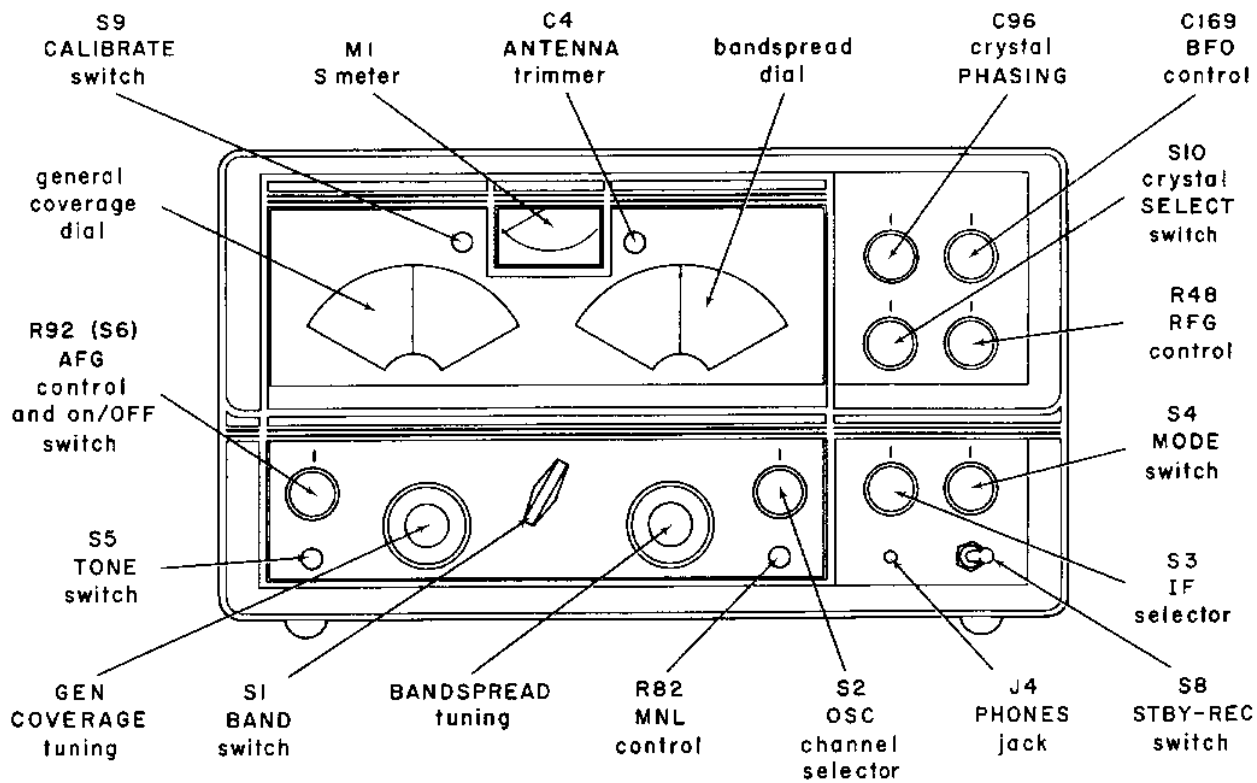

Figure 5. Panel Control Locations

BANDSPREAD Tuning. The bandspread dial and its mechanism are identical to those for general coverage except for the scale calibration which provides bandspread tuning of the amateur bands. A 0 to 100 logging scale is also included. The bandspread dial should be set to the red calibration line corresponding to frequencies of 4.0, 7.3, 14.4, 21.5 and 29.7 mc for proper calibration of the general coverage dial.

ANTENNA Trimmer. The ANTENNA control may be adjusted to match the first RF stage to the impedance of the antenna. After a signal is selected, the trimmer is adjusted for a maximum S-meter reading. If desired, the antenna may be peaked on background noise instead of a signal.

S Meter. The S meter measures signal strength with reference to the local ambient noise level. Because meter readings are related to the position of the RF Gain control, this control must be preset for proper S meter operation. To set the control, tune the receiver to a clear channel (no station) and adjust for a 0 to 1 S meter reading on background noise.

RFG Control. The RF Gain control adjusts the sensitivity of the receiver by controlling the gain of the

second RF stage and the first two IF stages. Clockwise rotation increases the gain.

3.2.2 IF and Detector Section Controls

IF Selector Switch. The IF selector is a six-position switch providing one crystal and three noncrystal degrees of selectivity, ranging from very sharp for CW reception to broad for high fidelity AM signal reception. The switch also selects either sideband of a SSB signal. The following degrees of selectivity are provided:

Switch Position	Bandpass (at -6 db)	IF Circuit
B(broad)	16 kc	Crystal filter not operating; six tuned circuits used
M(medium)	8 kc	
S(sharp)	4 kc	
VS(very sharp)	3.5 kc	10 tuned circuits; crystal filter provides 5 sharper degrees of selectivity to 150-cycle bandwidth
SB ₂ SB ₁	3.5 kc	14 tuned circuits used; bandwidth is 10 kc, 60 db down

Crystal SELECT Switch. The crystal SELECT switch provides five degrees of selectivity, from 3.5 kc to 150 cycles, with the crystal filter operating. The IF selector switch must be in position VS for operation. The selectivity increases progressively as the crystal SELECT switch is advanced to position 5.

Crystal PHASING Control. The crystal filter PHASING control may be used only when the crystal SELECT switch is in position 1 thru 5 and the IF selector switch is in position VS. The PHASING control balances the crystal bridge circuit. The PHASING control may be used to eliminate interfering signals or heterodynes.

MODE Switch. The MODE switch selects the modes of receiver operation as follows:

Switch Position	Type of Reception	Circuit
ANL (1)	AM (ANL)	Diode with ANL and AGC
AM (2)	AM	Diode with AGC
SSB (3)	SSB (MNL)	Heterodyne Detector, BFO, MNL, AGC
CW (4)	CW (MNL)	Heterodyne Detector, BFO, MNL

The BFO circuit operates simultaneously with the heterodyne detector on SSB and CW positions.

MNL Control. The MNL (manual noise limiter) control functions only with the MODE switch in positions SSB and CW. The MNL control is adjusted during SSB or CW reception for optimum noise clipping level. The optimum position will be determined by the relative strength of the received signal and the noise interference. Noise conditions vary with localities and band conditions, so the limiting level is a matter of personal choice. The MNL is double-ended and clips both positive and negative noise peaks.

3.2.3 Audio Section

AFG Control. The AFG (audio frequency gain) control will remove AC power when placed in its extreme counterclockwise position. Turning the AFG control slightly clockwise will actuate the switch and power the receiver. Increasing the clockwise rotation will increase the volume for headphone or loud-speaker operation.

TONE Switch. The TONE switch has two positions, N (normal) and LO (low). In the LO position the higher audio frequencies are attenuated and low fre-

quencies predominate; in the N position the audio response is flat over the usable frequency range of the receiver. The LO position may noticeably improve the readability of AM and SSB signals in the presence of heavy noise interference.

BFO Control. The BFO (beat frequency oscillator) control varies the pitch of the audio tone when receiving CW signals. The BFO control is set so the center mark is aligned with the panel mark for normal CW reception. For SSB reception, the BFO control is adjusted so that the SSB mark is aligned with the panel mark. With the BFO control in this position the IF selector switch will properly select between SB1 and SB2 positions. It is not necessary to move the BFO control when selecting one sideband or the other. See Section 3.3.2 for SSB application.

PHONES Jack. The PHONES jack will accept a standard phone plug. Headphones of the high or low impedance type may be used. The loud-speaker is silenced automatically when the phone plug is inserted.

3.2.4 Accessory Controls

CALIBRATE Switch. The CALIBRATE switch turns the XCU-400 Crystal Calibrator on or off and selects either the 0.1-mc or the 1-mc marker signals. When the XCU-400 Calibrator is plugged into the receiver the Calibrator provides a crystal-controlled test signal every 100 kc or 1 mc, so that dial calibrations may be checked. Refer to Section 6 for instructions for correcting the Crystal Calibrator frequency using station WWV.

Placing the CALIBRATE switch in the TUNE position connects the S meter to the HF oscillator circuit so that the receiver may be tuned to crystal-controlled channel frequencies in the absence of a signal. This position may be used with or without the Crystal Calibrator accessory unit.

HF Channel Selector. The HFO (high frequency oscillator) control is a seven-position switch for selecting normal, crystal-controlled, or externally controlled operation of the HF oscillator. The MAN position of this switch provides continuous manual tuning of the HF oscillator. Positions 1, 2, 3, 4, and 5 select one of five plug-in crystals for fixed-channel operation. Position EXT permits external control of the HF oscillator through the use of the HFO connector on the rear of the chassis. The HF oscillator cathode circuit is connected to the rear panel HFO connector.

STBY-REC Switch. The STBY-REC toggle switch is located on the front panel. In STBY position, this switch opens the plate supply circuit for the RF and IF stages. In REC position, the plate supply circuit is closed to operate the receiver. External relay operation of the STBY-REC switch circuit is described in Section 2.2.4.

3.3. MODES OF OPERATION

Before operating the receiver, turn the power switch ON by turning the AFG control clockwise, and note that the dial lamps light. Initially, set the receiver panel controls as follows:

AFG	1/2 clockwise
RFG	-- Full clockwise
STBY-REC	-- REC
CALIBRATE	— OFF
HFO (OSC)	MAN
BAND	-- Desired range
PHONES	-- Plug in phones or use speaker.
MNL	-- Full counterclockwise
TONE	— N
BFO	— Center position
MODE	— As desired
IF	... As desired
SELECT	— OFF
PHASING	— Center position

3.3.1 AM Phone Reception

Place the MODE switch in the AM or ANL position. Set the IF selector switch for the desired selectivity (section 3.2.2 describes the IF circuit and selectivity obtained at each switch position). Normally, positions B, M or S will be used, with position VS providing additional selectivity for reception of signals through heavy interference.

When position VS is used, the crystal IF filter is operative and the crystal SELECT and PHASING controls may be used for increased selectivity and rejection of heterodynes or other adjacent channel interference.

The ANTENNA trimmer should be adjusted for maximum signal strength. The TONE switch may be used to reduce high-pitched noise. The AFG control is used to adjust the audio output level and the RFG control may be adjusted for optimum signal reception, depending on received signal strength and background noise. The RFG control must be preset, as described in Section 3.2.1, for correct operation of the S meter.

3.3.2 SSB Reception

Place the MODE switch in position SSB. Set the IF selector switch to position SB₁ or SB₂. Set the BFO control so the SSB mark is in line with the panel mark.

The RFG control is usually left at the position providing proper S meter operation and the AFG control adjusted for the desired listening level.

Carefully tune the signal until the audio is clear and understandable. If the signal is not readable switch to the opposite sideband and retune the receiver for proper reception.

If the signal received does not have a suppressed carrier, or has only partial suppression, the tuning control may require a small readjustment to zero-beat the transmitted carrier. For signals with fully suppressed carriers (SSSC), the BFO control must be adjusted carefully to duplicate the relation of the suppressed carrier to the received sideband. The proper adjustment gives a natural pitch and quality to the received signal.

For SSSC signal reception, set the AFG control to maximum and adjust the RFG control for desired audio level. The special AGC circuit designed for SSB reception provides effective signal-level control during reception. The MNL control may be adjusted for optimum noise limiting.

3.3.3 CW Reception

Place the MODE switch in position CW. The BFO circuit operates in this position and the AGC is removed. Any IF selector position may be used, but position VS provides crystal filter operation. Maximum selectivity up to 150 cycles is available with the crystal SELECT switch in position 5. The BFO control should be set so the center mark is aligned with the panel mark. Careful tuning is required when maximum crystal selectivity is used, because of the narrow band-pass. The BFO control may be varied to adjust the signal pitch, and the MNL control may be used for noise suppression.

Adjust the crystal PHASING control carefully to obtain the maximum selectivity of 150 cycles. This is evident from the characteristic "ping" of the received code signals. The PHASING control may be used to eliminate interfering signals or heterodynes. Heterodynes well removed from the desired signal will be properly phased out with the PHASING control set near its center position. Heterodynes close to the desired signal will be removed with the PHASING control set approximately 90° right or left of its control position.

For reception of MCW (modulated CW) signals, the MODE switch may be placed in position AM or ANL and the IF selector switch in any desired position. The IF selector switch may be left in position VS and the crystal filter may be used to eliminate interference.

3.4 ACCESSORY CRYSTALS

BFO Crystals. To crystal-control the frequency of the BFO, remove plug P1A from its chassis socket. The socket location is shown in Figure 6. Insert a 455-kc series resonant crystal mounted in a type HC-6/U holder (or equivalent). For CW reception the BFO crystal should be shifted from 455 kc by the desired audio frequency. For single sideband reception the crystal should be selected for approximately 453.5 kc. Minor variations from these frequencies may be desirable for various operating conditions.

Fixed Channel Crystals. Five crystal sockets are available for fixed frequency operation of the HF oscillator. Figure 6 shows the location of these sockets. The socket nearest the front panel coincides with the No. 1 position of the channel OSC (HFO) switch, and the remaining sockets positions 2, 3, 4 and 5 are in direct order. The OSC (HFO) switch is independent of the BAND switch position, and the five fixed-channel crystals may be used on individual frequency bands or all on one band.

Crystal frequency and type for specific channels may be determined by referencing the following:

Crystal Specifications:

a. Crystal Description

1. 995 kc to 13,500 kc. Series resonant operation on the fundamental frequency of the crystal plate. To be used under controlled temperature conditions. Similar to military specifications for type CR-19/U in MIL-C-3098.
2. 13,500 kc to 32,720 kc. Series resonant operation on the third overtone mode of the crystal plate fundamental frequency. To be used under uncontrolled temperature conditions. Similar to military specifications for type CR-23/U in MIL-C-3098.

b. Frequency tolerance: $\pm 0.005\%$ over temperature range of -40°C to $+70^{\circ}\text{C}$.

c. Holder:

The crystal holder shown in sub-paragraph d. is a military type HC-6/U, having a maximum crystal unit capacitance of 7.0 uuf. Crystal socket adapters are available commercially and may be used in mounting crystal holders with a greater pin spacing. The substitute crystal holder must have electrical specification similar to the military type described.

d. Crystal Holder Dimensions

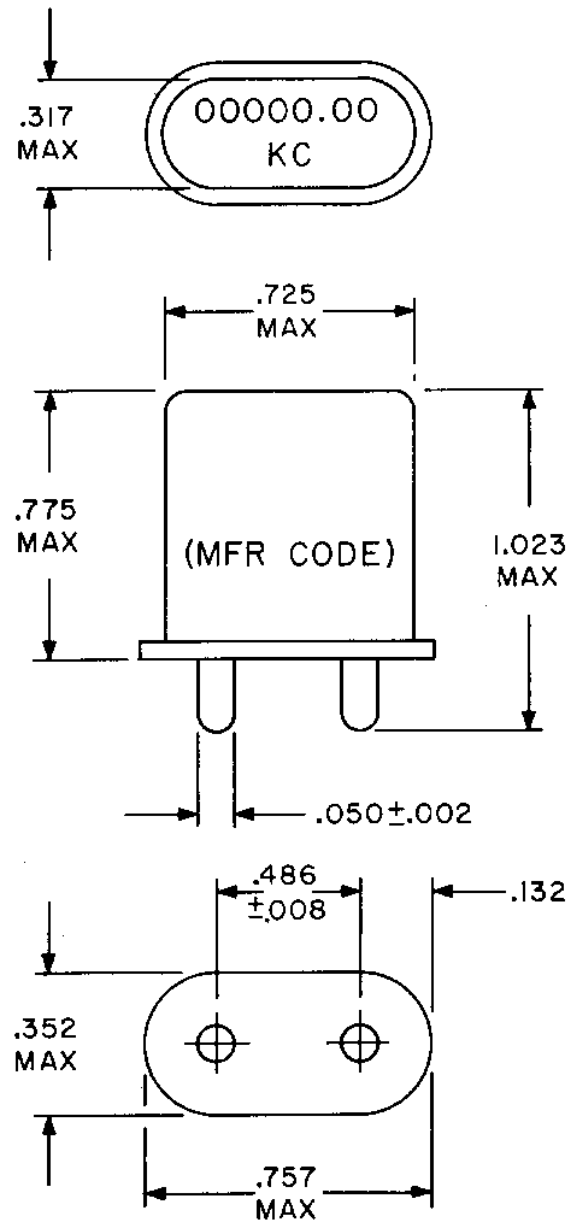

e. Crystal Frequency Calculation

For signal frequencies between 540 and 7,000 kc,

$$f_c = f_s + 455$$

where: f_c = crystal frequency in kc

f_s = desired signal frequency in kc.

For signal frequencies between 7,000 and 31,000 kc,

$$f_c = f_s + 1720.$$

f. Maximum Series Resistance

1. 995 kc to 13,500 kc.

From	800.000 to	999.999	..	800 ohms
	1,000.000 to	1,249.999	..	500
	1,250.000 to	1,499.999	..	400
	1,500.000 to	1,749.999	..	350
	1,750.000 to	1,999.999	..	300
	2,000.000 to	2,249.999	..	250
	2,250.000 to	3,749.999	..	150
	3,750.000 to	4,999.999	..	100
	5,000.000 to	6,999.999	..	50
	7,000.000 to	9,999.999	..	30
	10,000.000 to	20,000.000	..	25

2. 13,520 kc to 32,720 kc.

From	13,520.000 to	14,999.999	..	60 ohms
	15,000.000 to	32,720.000	..	40

To tune the receiver to a particular channel frequency in the absence of a signal, place the CALIBRATE switch in tune position. Select the channel crystal and place the BAND switch in the corresponding range. As the receiver is tuned through the signal frequency, the S meter will indicate the oscillator activity. Tune the receiver for maximum reading on the S meter. The receiver is now tuned to the crystal-controlled switch channel. The CALIBRATE switch may be returned to OFF position for normal S meter operation.

SECTION 4. MAINTENANCE

4.1 GENERAL

The NC-400 is designed for continuous duty and should normally require little attention except for tube replacement. The quality of components used and precision factory alignment of the tuned circuits assure dependable operation and consistent performance.

Vacuum tube failure in the receiver may reduce sensitivity, produce intermittent operation or cause complete equipment failure. In this event, all tubes should be tested or replaced with tubes of proven quality. Tubes of the same type may vary enough to affect the alignment of frequency-critical circuits; careful selection may be required. Alignment procedures are discussed in Section 5.

4.2 TROUBLE SHOOTING

In case of breakdown or failure of the receiver, the fault must first be localized to a particular section or stage before repairs can be made. Observation for peculiar control action or for evidence of improperly operating frequency ranges or reception modes may help to localize a malfunction.

The block diagram of the receiver, Figure 1, indicates the signal path from antenna to speaker and shows which stages are in operation for various positions of the circuit switches. When the trouble has been localized to a particular stage or circuit, visual examina-

tion of the related components may indicate the defective part. A voltage or resistance check of the suspected circuit should locate the defect. The chart in Figure 7 is a guide to such checks.

Part replacements must have the same value and tolerance as the original parts. Parts replacement in a frequency-critical circuit may require realignment of that circuit.

4.3 VOLTAGE MEASUREMENTS

All measurements shown in Figure 7 are made with a vacuum tube voltmeter. Voltage measurements are made with a 117-volt line. Panel controls are preset before measurements, in the following manner:

RFG Control	Full CW
AFG Control	Full CW
TONE Switch	N
CALIBRATE Switch	Off
OSC (HFO) Selector	Manual
MNL Control	Full CCW
IF Selector	VS
MODE Switch	CW
Crystal SELECT	Off
Crystal PHASING	Any position
STBY-REC Switch	REC
BAND Switch	Band 5
GENERAL COVERAGE	..	Tune to high end of band

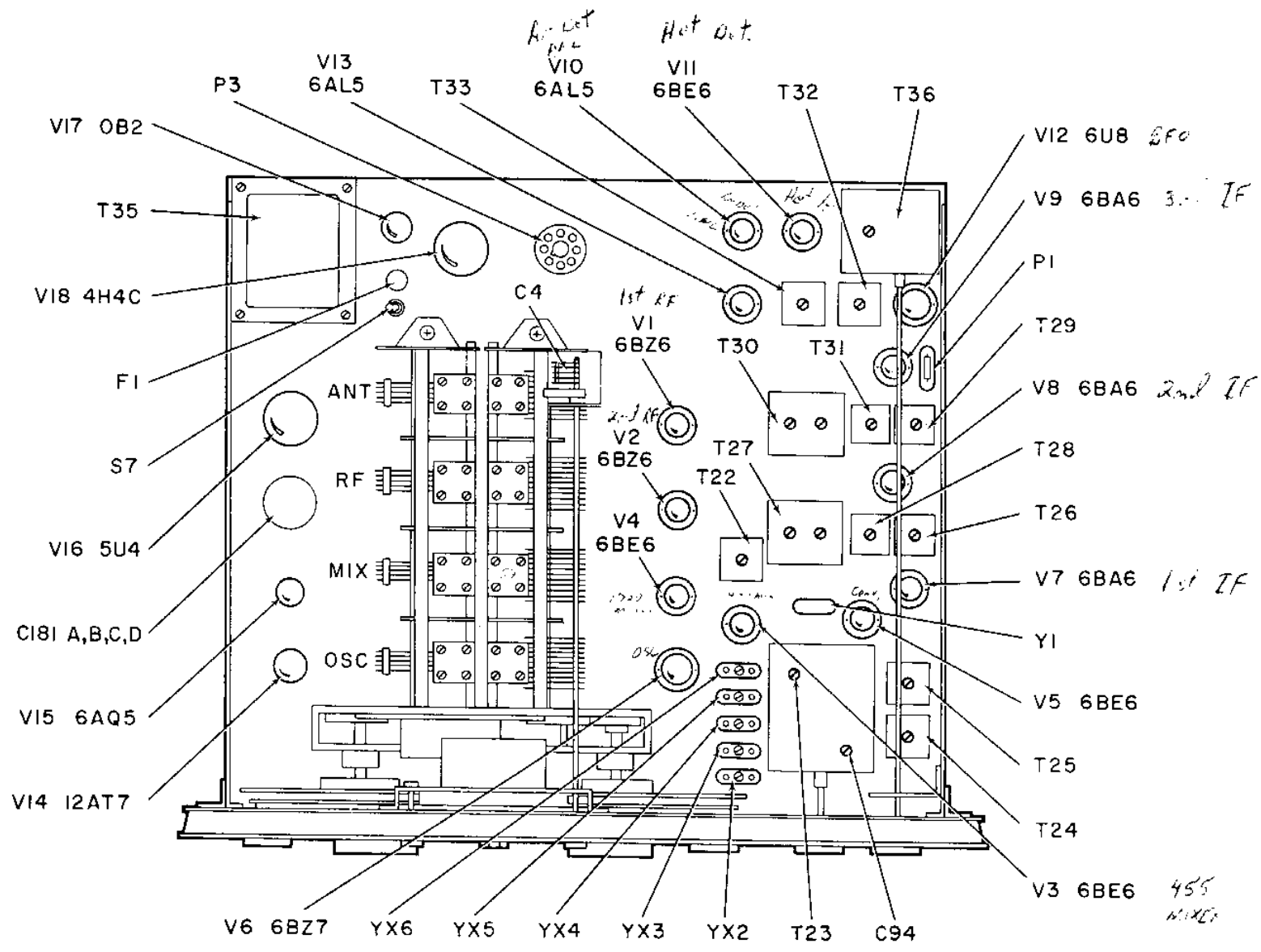

Figure 6. Tube Locations and Alignment Adjustments

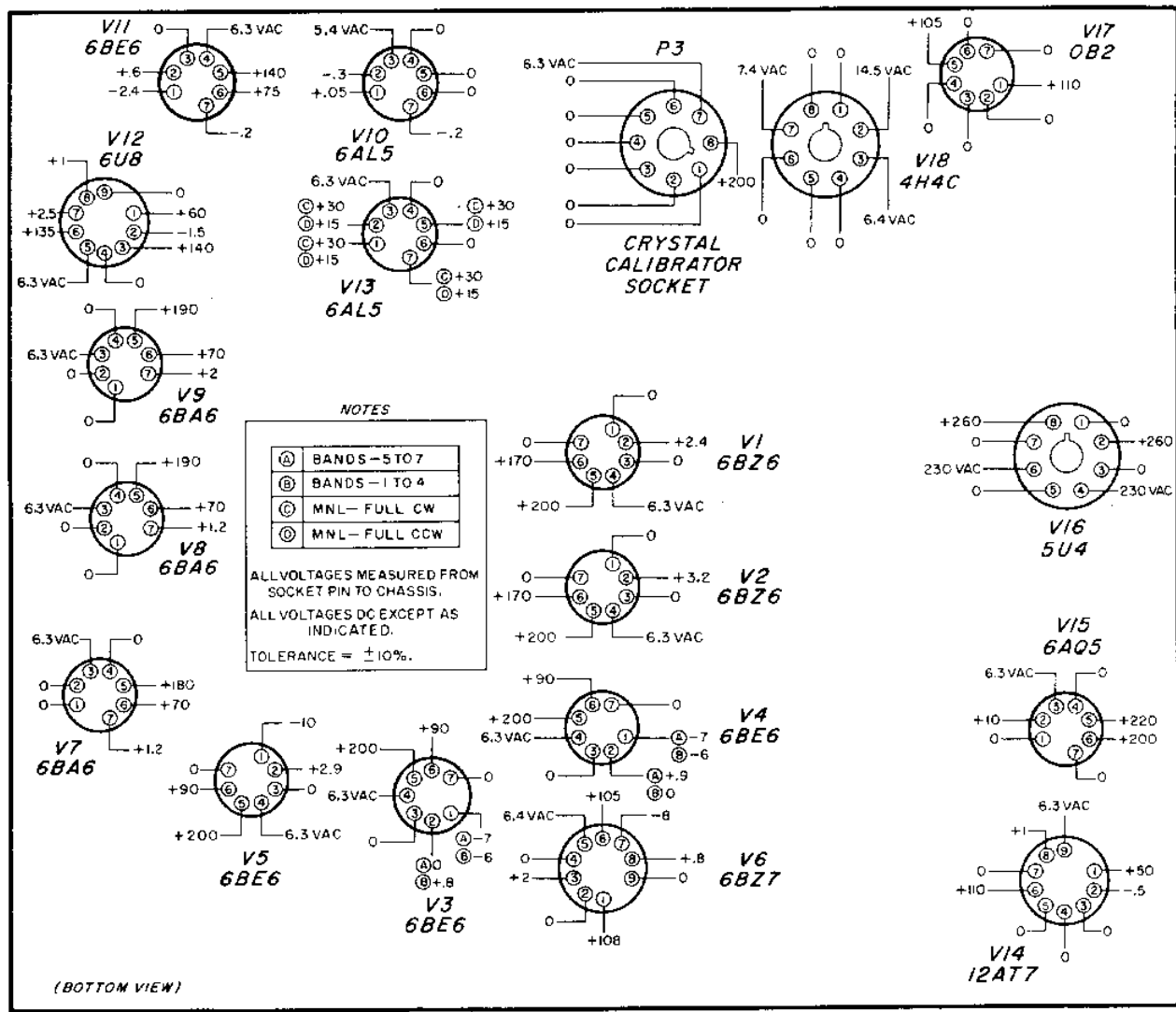
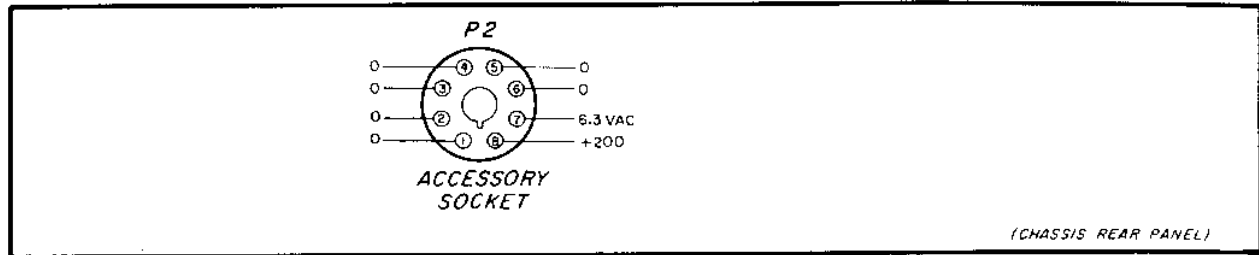

Figure 7. Voltage Measurements

SECTION 5. ALIGNMENT

5.1 GENERAL

Alignment of the NC-400 communications receiver requires precision instruments and a thorough understanding of the circuits. This receiver, having double conversion circuits and a dual IF section, presents a more involved alignment procedure than conventional superheterodynes.

Under normal conditions, the receiver will stay in alignment for long periods, but, if tubes or components are replaced or adjustments tampered with, the circuits will require alignment. Alignment should not be attempted unless indicated by receiver malfunction.

The complete alignment of the receiver is divided into two parts---IF alignment and RF alignment. Adjustments must be made in the sequence given on the alignment chart of Figure 8. Panel controls must be preset as described. A warm-up period of one hour or more is recommended before frequency-determining circuits are aligned. Small changes in the position of alignment screws are sufficient to adjust the circuits, so each adjustment must be performed carefully.

5.2 INSTRUMENTS

The minimum test instruments required for alignment are as follows:

Signal Generator (455 kc to 35 mc)

VTVM (rms)

Headphones (or loud-speaker)

Alignment tools

Headphones are useful during alignment as they provide an aural signal indication which supplements the output meter readings. The Model XCU-400 Crystal Calibrator (accessory) may be used to check dial scale calibration after receiver alignment.

5.3 IF ALIGNMENT

Steps 1 to 7 of Figure 8 list adjustments for alignment of the IF section; step 8 describes the BFO adjustments. Alignment must be made in the sequence given. Refer to Figures 6 and 9 for location of alignment adjustments.

Test Instruments. Connect the signal generator from chassis to the stator of C44 through a 0.01 mfd condenser. Connect the VTVM as an output indicator across the 3.2 ohm terminals of TB-2. Except for the BFO adjustment, the signal generator output is modulated (400 cy 30%).

Remove AGC. Short pins 5 and 6 on the accessory plug P2A, to ground the AGC bus circuit.

Preset Controls. Set all panel controls as follows:

BAND	Band 1
MODE	AM
AFG	Full CW
RFG	Full CW
STBY/REC	REC
BFO	To mark
PHASING	Central
Crystal SELECT	OFF
ANTENNA	Anywhere
IF	VS
OSC (HFO)	MAN
MNL	Full CCW
TONE	N
General Coverage	To HF end
Bandspread	At "SET"
CALIBRATE	OFF

During alignment adjustments, reduce the output level of the signal generator to prevent circuit overload. If the receiver is badly misaligned, it may be necessary to connect the signal generator to the grid of the third IF stage and align the last IF transformer and successively align the other IF circuits, working forward to the mixer grid.

Steps 2, 4 and 8 require tuning the signal generator ± 200 cy from 455 kc to locate the crystal resonance for IF alignment at the frequency of the crystal filter. This frequency is indicated by a sharp rise in the output level.

Repeat each adjustment step to verify the circuit alignment.

5.4 RF ALIGNMENT

Steps 9 to 22 of Figure 8 indicate the alignment required for the HFO, mixer, RF and antenna stages. Alignment for each band must be performed in the step sequence given. Figures 6 and 9 show locations of the adjustments.

Test Instruments. Connect the signal generator to the antenna input connector (J1); the VTVM remains across the 3.2 ohm terminals of TB-2.

Remove AGC. Pins 5 and 6 are shorted at plug P2 to ground the AGC bus.

NOTE

Before attempting the RF Alignment procedure:

1. Place the general coverage tuning dial in its full counterclockwise position (low frequency end). This should place the general coverage capacitor within one rotational degree of its completely meshed position.
2. Place the bandspread tuning dial in its full counterclockwise position (low frequency end). This should place the bandspread capacitor in its fully meshed position.

Preset Controls. Set all panel controls as follows:

BAND	As indicated
MODE	CW
AFG	Full CW
RFG	As needed
STBY/REC	REC
BFO	To mark
PHASING	To mark
Crystal SELECT	OFF
ANTENNA	Anywhere
IF	VS
OSC (HFO)	MAN

MNL	Full CCW
TONE	N
General Coverage	As indicated
Bandspread	At "SET"
CALIBRATE	OFF

Each BAND requires trimmer and inductance adjustments. To adjust the step 10 inductance, change the position of the loop at the coil end. HFO adjustments may have to be repeated several times, because the inductance adjustments affect the previous trimmer adjustment. Reduce the output level of the signal generator during alignment to prevent circuit overload. The RFG control may also be used to reduce the signal level.

All HFO circuit adjustments require setting the receiver dial to the alignment frequency, and adjusting the oscillator alignment screws until the signal is received. The mixer, RF and antenna circuits are then adjusted for maximum signal level.

Image Check. The HF oscillator in the NC-400 receiver is designed to operate above the signal frequency. It is possible to misadjust the oscillator circuits so that the HFO is operating below the signal frequency. After aligning the HFO circuit (for a given band), verify correct oscillator operation by tuning the signal generator to the image frequency for that band. The image should occur 3.44 mc **above** the signal frequency on bands 5, 6 and 7 and 910 kc above the signal on bands 1, 2, 3 and 4. If the image is **below** the signal instead of above, the oscillator frequency is incorrect and the circuit must be realigned.

IF ALIGNMENT CHART

STEP	GEN. FREQ.	IF SELECT	BAND	CRYSTAL SELECT	ADJUST	ADJUST FOR
1	455 kc	VS	1	OFF	T32, T31, T29, T28, T26	Maximum output
2	Xtal (*)	"	"	5	T32, T31, T29, T26, T28 T23	Max. (at Xtal freq.)
3	457 kc	"	"	1	L11	Maximum output
4	Xtal (*)	"	"	OFF	C94	Max. (at Xtal freq.)
5	455 kc	SB2	"	OFF	T25, T24	Maximum output
6	455 kc	S	"	OFF	T27, T30, T33	Maximum output
7	1720 kc	VS	5	OFF	T22	Maximum output
8	Xtal (*)	"	1	OFF	T36 (BFO) no mod.	Adjust for zero beat

RF ALIGNMENT CHART

STEP	BAND	FREQ.	HFO ADJUST	ADJUST FOR MAXIMUM OUTPUT	NOTE
9	7	30 mc	C81	C38, C19, ANTENNA trimmer	Check image
10	7	20 mc	L9	T21, T14, T7 (loop in coil end)	Repeat steps 10-11
11	6	20 mc	C80	C37, C18, ANTENNA trimmer	Check image
12	6	12 mc	L8	T20, T13, T6	Repeat steps 12-13
13	5	12 mc	C79	C36, C17, ANTENNA trimmer	Check image
14	5	7.5 mc	L7	T19, T12, T5	Repeat steps 14-15
15	4	7 mc	C78	C35, C16, ANTENNA trimmer	Check image
16	4	4.2 mc	L6	T18, T11, T4	Repeat steps 16-17
17	3	4 mc	C77	C34, C15, ANTENNA trimmer	Check image
18	3	2.5 mc	L5	T17, T10, T3	Repeat steps 18-19
19	2	2 mc	C76	C33, C14, ANTENNA trimmer	Check image
20	2	1.2 mc	L4	T16, T9, T2	Repeat steps 20-21
21	1	1 mc	C75	C32, C13, ANTENNA trimmer	Check image
22	1	.6 mc	L3	T15, T8, T1	Repeat steps 22-23

(*) 455 kc \pm 200 cy.

Figure 8. Alignment Chart

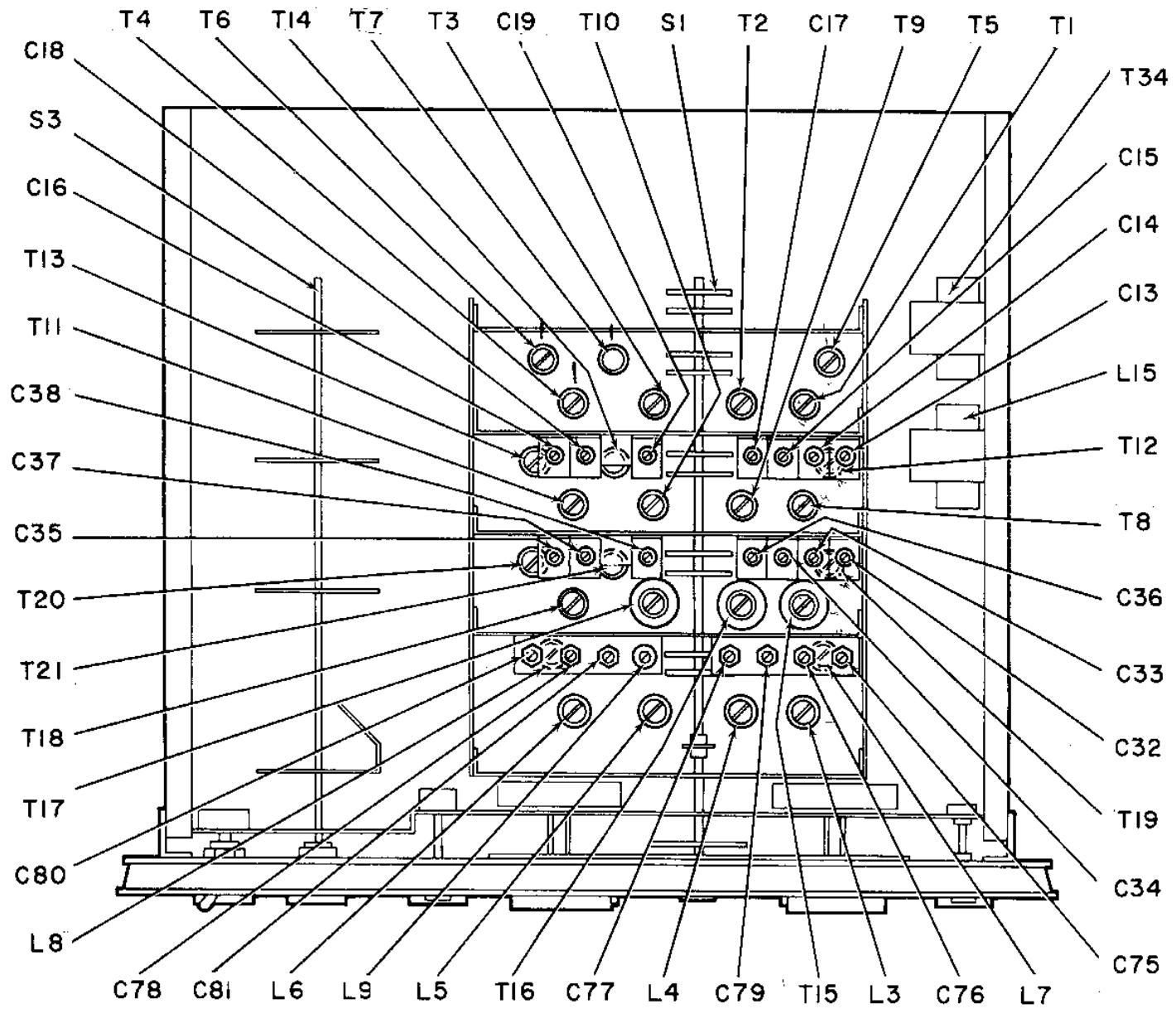

Figure 9. Alignment Adjustments (Bottom Chassis)

SECTION 6. ACCESSORIES

6.1 CRYSTAL CALIBRATOR UNIT (XCU-400)

General. The model XCU-400 Crystal Calibrator unit is designed for operation with the NC-400 communications receiver. Each calibrator is factory-adjusted to zero beat with station WWV, and will accurately provide 100 kc and 1 mc marker frequencies for the NC-400 receiver.

Installation. To install the calibrator, plug it into the socket, P3, on the top of the chassis (see Figure 6).

Operation. The XCU-400 Crystal Calibrator provides an accurate means of checking the frequency calibration of the NC-400 receiver dials. The CALIBRATE switch,

on the receiver panel, provides selection of the 100-kc or 1-mc marker frequencies. The OFF position removes B-plus from the calibrator. The TUNE position of this switch is not used for calibrator operation.

Calibrator Check. The NC-400 receiver provides a control for adjusting the crystals in the calibrator to WWV, by an adjustment (C1, Figure 10) in an opening in the calibrator case. Check the adjustment by tuning station WWV on the receiver, turning the CALIBRATE switch to the 100 kc position, and zero-beating with WWV. A small readjustment of C1 may be required to compensate for crystal and component aging over long periods.

XCU-400 PARTS LIST

SYM-BOL	DESCRIPTION	NATCO TYPE
C1	Capacitor, Variable: 5-30 mmf	A-50034-1
C2	Capacitor, Ceramic: 0.02 mfd, \pm no limit -0%	2-C63-Z5V-203-GMV
C3	Capacitor, Mica: 100 mmf, \pm 10%, 500 wvdc	NCS-15-101-K-5
C4	Same as C2	
C5	Capacitor, Mica: 10mmf \pm 10%, 500 wvdc	NCS-15-100-K-5
L1	Inductor, Fixed: 160 microhenries	ASB-1136
L2	Inductor, Fixed: 4.7 millihenries	B-17308

SYM-BOL	DESCRIPTION	NATCO TYPE
P1	Plug, Octal	K-785-1
R1	Resistor, Fixed: 4.7 megohms, \pm 20%, 1/2 watt	RC-20-BF-475-M
R2	Resistor, Fixed: 470 K ohm, \pm 20%, 1/2 watt	RC-20-BF-474-M
R3	Resistor, Fixed: 100 K ohm, \pm 20%, 1/2 watt	RC-20-BF-104-M
V1	Tube: type 6AU6	
Y1	Crystal, Quartz: 1 mc	B-19865
Y2	Crystal, Quartz: 100 kc	A-16126

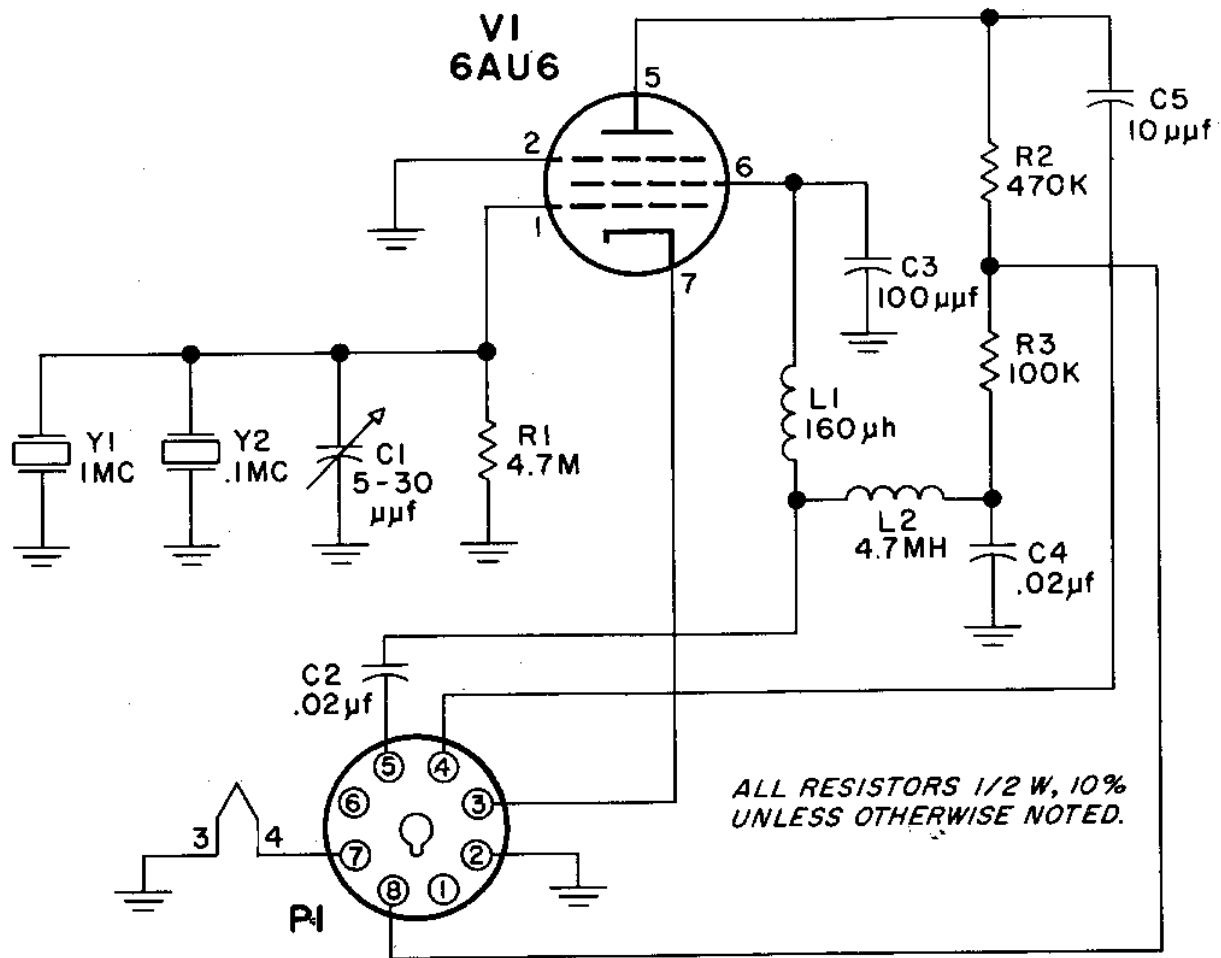

Figure 10. Schematic, XCU-400 Crystal Calibrator

6.2 MECHANICAL FILTER HOUSING

General. The Model MFH-400 Mechanical Filter Housing is designed for operation in the NC-400 receiver in place of the plug-in crystal filter. The housing accepts up to three commercial-type mechanical filters. The unit provides suitable matching circuits for the filters and allows front panel selection of selectivities ranging from 16 kc to 500 cps or SSB dependent upon filter unit installed.

Installation. To install the mechanical filter unit, perform the following steps.

- a. Remove the PHASING and SELECT control

knobs from the crystal filter control shafts. Remove the shaft extensions.

- b. Remove the retaining lock nuts (3).
- c. Unplug the crystal filter unit from the receiver chassis.
- d. Insert the mechanical filter into the chassis plugs.
- e. Replace lock nuts removed in step b.
- f. Reinstall a shaft extension on the mechanical filter SELECT shaft and replace the SELECT control knob on this shaft, indexing the knob to the panel mark.
- g. Plug the remaining shaft hole with the button provided.

Operation. The mechanical filter operates with the receiver IF switch in positions VS, S, M and B. The first position of the SELECT switch is OFF. This removes the mechanical filters from the circuit and substitutes a single tuned circuit. Positions one, two and three provide various bandpasses depending upon the mechanical filters installed.

Adjustments. The Model MHF-400 Mechanical Filter is tested and adjusted at the factory and should not require readjustment when installed in the NC-400 receiver. Holes are provided in the filter case for alignment adjustments of the input, output and the OFF position circuits. If realignment is necessary after prolonged service, the following adjustments may be made using the receiver S-meter as an alignment indicator.

a. Short-circuit pins 5 and 6 of accessory plug P2A to remove the AGC action.

b. Tune the receiver to a station of low signal strength with the IF switch in VS position and the mechanical filter SELECT switch in its sharpest position.

c. Tune in the station for greatest S-meter reading and adjust C2 and C5 in the mechanical filter for an increase in meter reading.

d. Set the SELECT switch to OFF position and adjust L1 for greatest meter reading.

e. Remove the short at plug P2A.

MECHANICAL FILTER PARTS LIST

SYM-BOL	DESCRIPTION	NATCO TYPE
C1	Capacitor, Mica: .001 mfd, $\pm 10\%$, 500wvdc	NCS-20-102-K-5
C2	Capacitor, Trimmer: 5-80 mmf	A-12312-2
C3	Capacitor, Mica: 68 mmf, $\pm 10\%$, 500wvdc	NCS-15-680-K-5
C4	Capacitor, Mica: 470 mmf, $\pm 10\%$, 500 wvdc	NCS-20-471-K-5
C5	Same as C2	
C6	Same as C1	
FL1	Filter, Mechanical	
FL2	Filter, Mechanical	

SYM-BOL	DESCRIPTION	NATCO TYPE
FL3	Filter, Mechanical	
L1	Inductor, Variable	B-50015
P1	Connector	B-24849
P2	Same as P1	
R1	Resistor, Fixed: 27 K ohms, $\pm 10\%$, 1/2 watt	RC-20-BF-273-K
R2	Resistor, Fixed: 2.7 K ohms, $\pm 10\%$, 1/2 watt	RC-20-BF-272-K
R3	Resistor, Fixed: 470 K ohms, $\pm 10\%$, 1/2 watt	RC-20-BF-474-K
S1	Switch, Selector	C-50006

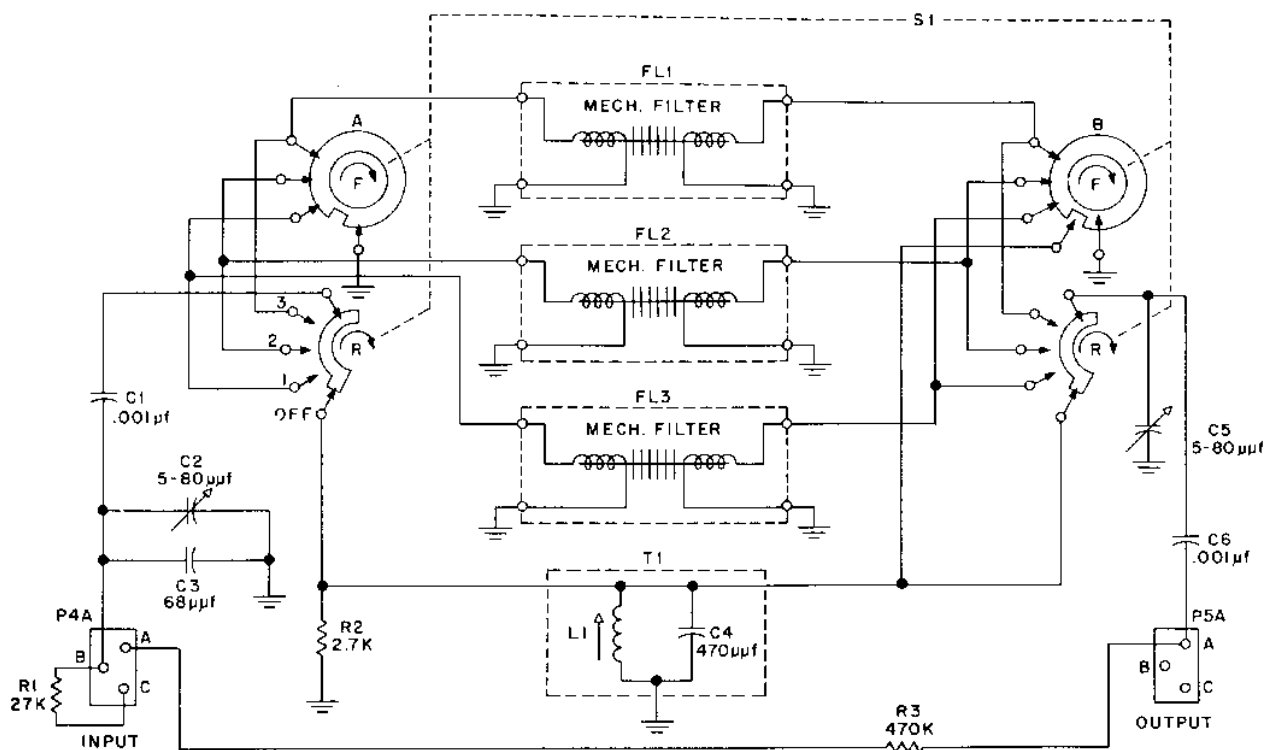

Figure 11. Schematic, MFH Mechanical Filter Housing

6.3 DIVERSITY MODIFICATION KIT

General. The Model DMK Diversity Kit is available on special order for diversity conversion of the NC-400 receiver. The kit includes all components, partially wired circuits and the necessary instructions for easy conversion of the receiver. Receptacles to be mounted in the receiver are standard Amphenol UHF receptacles, catalogue 83-1R. These mate with Amphenol cable connectors, catalogue 83-1SP.

An IF output circuit is provided on the chassis rear panel for use where IF signals are required in diversity combiners. AGC output is supplied to pin 5 of Accessory Socket P2. Detector output is provided at pin

2 of P2 and is jumped to pin 1 of P2 by means of plug P2A supplying normal audio feed in the receiver. In diversity applications it is possible to parallel detector loads of two receivers by interconnecting pin 2 of the respective accessory sockets. The jumper between pins 1 and 2 may be broken on one of the two receivers, in the diversity application, in order that both detectors feed a common detector load and audio circuits. It is also possible to break these jumpers in both receivers of a diversity set-up, interconnect pin 2 of both receivers and use a common external detector load. In this event it is possible to break the jumper between pins 3 and 4 of one or both receivers and feed pin 4 with the audio signal obtained from the external detector load or diversity combiner.

NC-400 PARTS LIST

CAPACITORS

SYM-BOL	DESCRIPTION	NATCO TYPE
C1	Mica: 22 mmf, ±10%, 300 wvdc	NCS-15-220-K-3
C2	Mica: 68 mmf, ±10%, 300 wvdc	NCS-15-680-K-3
C3	Mica: 100 mmf, ±10%, 300wvdc	NCS-15-101-K-3
C4	Variable: 5-50 mmf (Ant. Trim.)	B-19781-A
C5	Variable: 10-30 mmf (Band Spread)	C-20612
C6	Variable: 10-200mmf (Gen'l. Cov.)	C-20611
C7	Ceramic: 0.01 mfd, +22%-75%, 500 wvdc	2-C14-Z5V-103- GMV
C8	Ceramic: 0.003 mfd, ±22%, 500 wvdc	2-C14-Z5S-332-M
C9	Same as C7	
C10	Same as C7	
C11	Same as C7	
C12	Mica: 1.5 mmf, ±0.5 mmf, 300 wvdc	NCS-15-1R5-X-3
C13	Variable: 5-80 mmf (Trim.)	B-20687-1
C14	Same as C13	
C15	Same as C13	
C16	Variable: 5-80 mmf (Trim.)	B-20687-2
C17	Same as C13	
C18	Same as C16	
C19	Same as C16	
C20	Same as C1	
C21	Mica: 33 mmf, ±10%, 300 wvdc	NCS-15-330-K-3
C22	Mica: 56 mmf, ±5%, 300 wvdc	NCS-15-560-J-3
C23	Mica: 150 mmf, ±2%, 300 wvdc	NCS-15-151-G-3
C24	Same as C5	
C25	Same as C6	
C26	Same as C7	

SYM-BOL	DESCRIPTION	NATCO TYPE
C27	Mica: 470 mmf, ±20%, 500 wvdc	NCS-20-471-M-5
C28	Same as C7	
C29	Same as C7	
C30	Same as C7	
C31	Same as C12	
C32	Same as C13	
C33	Same as C13	
C34	Same as C13	
C35	Same as C16	
C36	Same as C13	
C37	Same as C16	
C38	Same as C16	
C39	Paper: 0.47 mfd, 400 vdcw, ±20%	NCP-4-474-M
C40	Mica: 10 mmf, ±0.5 mmf, 300 wvdc	NCS-15-100-X-3
C41	Mica: 56 mmf, ±5%, 300 wvdc	NCS-15-560-J-3
C42	Mica: 150 mmf, ±2%, 300 wvdc	NCS-15-151-G-3
C43	Same as C5	
C44	Same as C6	
C45	Mica: 47 mmf, ±10%, 500 wvdc	NCS-15-470-K-5
C46	Same as C7	
C47	Same as C7	
C48	Same as C7	
C49	Same as C7	
C50	Mica: 510 mmf, ±5%, 300 wvdc	S-659-1
C51	Same as C7	
C52	Same as C50	
C53	Same as C7	
C54	Ceramic: 33 mmf, ±10%, 500 wvdc	2-C11-Z5P-330-K
C55	Ceramic: 470 mmf, ±10%, 500 wvdc	2-C61-Z5P-471-K
C56	Same as C7	
C57	Ceramic: 0.02 mfd, + no limit, -0%, 500 wvdc	2-C14-Z5V-203- GMV

PARTS LIST (CONT'D)

CAPACITORS (CONT'D)

SYM-BOL	DESCRIPTION	NATCO TYPE
C58	Same as C7	
C59	Mica: 0.001 mfd, ±20%, 500 wvdc	NCS-20-102-M-5
C60	Same as C27	
C61	Same as C7	
C62	Same as C59	
C63	Same as C7	
C64	Same as C59	
C65	Same as C5	
C66	Same as C6	
C67	Same as C7	
C68	Ceramic: 4 mmf, ±0.25 mmf, 500 wvdc	CCC-20-UJ-040-C
C69	Ceramic: 5 mmf, ±0.25 mmf, 500 wvdc	D-825-D-483
C70	Ceramic: 5 mmf, ±0.25 mmf, 500 wvdc	CCC-20-UJ-050-C
C71	Same as C1	
C72	Mica: 27 mmf, ±10%, 300 wvdc	NCS-15-270-K-3
C73	Same as C41	
C74	Same as C23	
C75	Variable: 3-32 mmf	B-20688-1
C76	Same as C75	
C77	Variable: 2.3-14.2 mmf	B-20688-2
C78	Same as C75	
C79	Same as C75	
C80	Same as C75	
C81	Same as C75	
C82	Mica: 320 mmf, ±2%, 300 wvdc	NCS-15-321-G-3
C83	Mica: 570 mmf, ±2%, 300 wvdc	NCS-15-571-G-3
C84	Mica: 1230 mmf, ±2%, 300 wvdc	NCS-19-1231-G-3
C85	Mica: 1990 mmf, ±5%, 300 wvdc	NCS-19-1991-J-3
C86	Same as C84	

SYM-BOL	DESCRIPTION	NATCO TYPE
C87	Same as C85	
C88	Mica: 2830 mmf, ±5%, 300 wvdc	NCS-19-2831-J-3
C89	Mica: 270 mmf, ±10%, 500 wvdc	NCS-20-271-K-5
C90	Ceramic: 5 mmf, ±0.5 mmf, 500 wvdc	CCC-21-CK-050-D
C91	Same as C7	
C92	Mica: 68 mmf, ±5%, 500 wvdc	NCS-15-680-J-5
C93	Same as C92	
C94	Variable: 3.5-35 mmf (Trim.)	A-12312-1
C95	Mica: 270 mmf, ±5%, 500 wvdc	S-659-3
C96	Variable: 4-14 mmf	B-19985
C97	Ceramic: 7 mmf, ±.5 mmf, 500 wvdc	CCC-20-CK-070-D
C98	Mica: 68 mmf, ±10%, 500 wvdc	NCS-15-680-K-5
C99	Ceramic: 3 mmf, ±.5 mmf, 500 wvdc	CCC-20-CK-030-D
C100	Same as C90	
C101	Same as C95	
C102	Ceramic: 10 mmf, ±1.0 mmf, 500 wvdc	CCC-20-CK-100-F
C103	Ceramic: 25 mmf, ±10%, 500 wvdc	CCC-20-CK-250-K
C104	Same as C95	
C105	Same as C103	
C106	Mica: 56 mmf, ±10%, 500 wvdc	NCS-15-560-K-5
C107	Same as C90	
C108	Same as C95	
C109	Same as C90	
C110	Same as C7	
C111	Same as C57	
C112	Same as C7	
C113	Same as C57	
C114	Same as C95	
C115	Same as C90	

PARTS LIST (CONT'D)

CAPACITORS (CONT'D)

SYM-BOL	DESCRIPTION	NATCO TYPE
C116	Mica: 510 mmf, ±5%, 500 wvdc	H-500-5
C117	Same as C90	
C118	Same as C95	
C119	Same as C95	
C120	Same as C116	
C121	Same as C90	
C122	Same as C7	
C123	Same as C95	
C124	Same as C90	
C125	Same as C57	
C126	Same as C7	
C127	Same as C57	
C128	Same as C95	
C129	Same as C90	
C130	Same as C116	
C131	Same as C90	
C132	Same as C95	
C133	Same as C95	
C134	Same as C116	
C135	Same as C90	
C136	Same as C7	
C137	Same as C95	
C138	Same as C90	
C139	Same as C57	
C140	Same as C57	
C141	Same as C57	
C142	Same as C90	
C143	Same as C95	
C144	Same as C7	
C145	Same as C90	
C146	Ceramic: 100 mmf, ±10%, 500 wvdc	2-C62-Z5P-102-K
C147	Mica: 100 mmf, ±10%, 500 wvdc	NCS-15-101-K-5
C148	Same as C95	
C149	Mica: 510 mmf, ±10%, 500 wvdc	CM-13-D-511-K
C150	Paper: 0.1 mfd, 400 wvdc, +20%	NCP-4-104-M
C151	Same as C147	

SYM-BOL	DESCRIPTION	NATCO TYPE
C152	Mica: 3 mmf, ±0.5 mmf, 500 wvdc	NCS-15-030-X-5
C153	Same as C7	
C154	Same as C55	
C155	Paper: 0.022 mfd, ±20%, 200 wvdc	NCP-2-223-M
C156	Same as C7	
C157	Same as C7	
C158	Paper: 1.0 mfd, ±20%, 50 wvdc	B-25548
C159	Same as C55	
C160	Same as C7	
C161	Same as C146	
C162	Mica: 470 mmf, ±5%, 500 wvdc	NCS-20-471-J-5
C163	Same as C7	
C164	Mica: 220 mmf, ±10%, 500 wvdc	NCS-20-221-K-5
C165	Same as C150	
C166	Mica: 390 mmf, ±5%, 500 wvdc	NCS-20-391-J-5
C167	Same as C57	
C168	Same as C150	
C169	Variable: 3.5-9 mmf	B-19781-3
C170	Same as C7	
C171	Ceramic: 22 mmf, ±5%, 500 wvdc	CCC-20-UJ-220-J-5
C172	Same as C57	
C173	Same as C155	
C174	Same as C57	
C175	Same as C7	
C176	Same as C57	
C177	Deleted	
C178	Mica: 0.001 mfd, 1000 vdc	J-667-50
C179	Same as C178	
C180	Same as C178	
C181	Electrolytic: 20-20-40 mfd, 300 vdc 20 mfd, 250 vdc	

PARTS LIST (CONT'D)

RESISTORS*

SYM-BOL	DESCRIPTION	NATCO TYPE
R1	Fixed: 470 K ohms, $\pm 20\%$	RC-20-BF-474-M
R2	Fixed: 180 ohms	RC-20-BF-181-K
R3	Fixed: 10 K ohms	RC-20-BF-103-K
R4	Fixed: 1200 ohms	RC-20-BF-122-K
R5	Fixed: 220 ohms, $\pm 20\%$	RC-20-BF-221-M
R6	Fixed: 270 ohms	RC-20-BF-271-K
R7	Same as R1	
R8	Same as R2	
R9	Same as R3	
R10	Fixed: 680 ohms	RC-20-BF-681-K
R11	Fixed: 4700 ohms	RC-20-BF-472-K
R12	Same as R11	
R13	Fixed: 3300 ohms	RC-20-BF-332-K
R14	Fixed: 2700 ohms	RC-20-BF-272-K
R15	Same as R5	
R16	Same as R2	
R17	Fixed: 1 megohm, $\pm 20\%$	RC-20-BF-105-M
R18	Fixed: 150 ohms	RC-20-BF-151-K
R19	Same as R1	
R20	Same as R18	
R21	Same as R17	
R22	Same as R11	
R23	Fixed: 2200 ohms, $\pm 20\%$	RC-20-BF-222-M
R24	Fixed: 22 ohms, $\pm 20\%$	RC-20-BF-220-M
R25	Same as R1	
R26	Fixed: 470 ohms	RC-20-BF-471-K
R27	Fixed: 47 K ohms	RC-20-BF-473-K
R28	Fixed: 100 K ohms	RC-20-BF-104-K
R29	Same as R17	
R30	Fixed: 47 ohms	RC-20-BF-470-K
R31	Fixed: 18 K ohms	RC-20-BF-183-K
R32	Same as R31	

SYM-BOL	DESCRIPTION	NATCO TYPE
R33	Fixed: 100 ohms	RC-20-BF-101-K
R34	Fixed: 470 ohms, $\pm 20\%$	RC-20-BF-471-M
R35	Fixed: 68 ohms	RC-20-BF-680-K
R36	Fixed: 330 ohms	RC-20-BF-331-K
R37	Fixed: 47 ohms, $\pm 20\%$	RC-20-BF-470-M
R38	Fixed: 15 ohms	RC-20-BF-150-K
R39	Fixed: 100 ohms, $\pm 20\%$	RC-20-BF-101-M
R40	Same as R39	
R41	Same as R23	
R42	Same as R1	
R43	Fixed: 33 ohms	RC-20-BF-330-K
R44	Fixed: 120 ohms	RC-20-BF-121-K
R45	Same as R27	
R46	Same as R23	
R47	Same as R1	
R48	Variable: 8 K ohms, wire-wound	B20660
R49	Same as R43	
R50	Fixed: 47 K ohms, 2 watt	RC-42-BF-473-K
R51	Same as R44	
R52	Same as R27	
R53	Same as R23	
R54	Same as R1	
R55	Fixed: 220 ohms	RC-20-BF-221-K
R56	Same as R28	
R57	Fixed: 33 K ohms	RC-20-BF-333-K
R58	Same as R23	
R59	Fixed: 150 K ohms	RC-20-BF-154-K
R60	Same as R17	
R61	Fixed: 470 K ohms	RC-20-BF-474-K
R62	Same as R28	

*All resistors 1/2 watt, 10% tolerance
unless noted otherwise.

PARTS LIST (CONT'D)

RESISTORS (CONT'D)*

SYM-BOL	DESCRIPTION	NATCO TYPE
R63	Same as R27	
R64	Same as R61	
R65	Same as R1	
R66	Fixed: 68 K ohms	RC-20-BF-683-K
R67	Same as R59	
R68	Same as R33	
R69	Fixed: 270 K ohms, $\pm 20\%$	RC-20-BF-274-M
R70	Same as R17	
R71	Fixed: 1500 ohms, $\pm 20\%$	RC-20-BF-152-M
R72	Same as R6	
R73	Fixed: 22 K ohms	RC-20-BF-223-K
R74	Fixed: 1800 ohms, 1/4 watt	RC-09-BF-182-K
R75	Fixed: 270 K ohms	RC-20-BF-274-K
R76	Same as R57	
R77	Same as R23	
R78	Same as R6	
R79	Fixed: 220 K ohms, $\pm 20\%$	RC-20-BF-224-M
R80	Same as R26	
R81	Same as R79	
R82	Variable: 100 K ohms	A-20679
R83	Same as R73	
R84	Fixed: 270 ohms	RC-20-BF-271-K

SYM-BOL	DESCRIPTION	NATCO TYPE
R85	Same as R27	
R86	Fixed: 10 K ohms, $\pm 20\%$	RC-20-BF-103-M
R87	Same as R61	
R88	Same as R28	
R89	Same as R34	
R90	Fixed: 10 megohm, $\pm 20\%$	RC-20-BF-106-M
R91	Same as R90	
R92	Variable: 500 K ohms	C-20673
R93	Fixed: 1000 ohms	RC-20-BF-102-K
R94	Variable: 1000 ohms	B-27657
R95	Same as R1	
R96	Same as R79	
R97	Fixed: 18 megohms	RC-20-BF-186-K
R98	Fixed: 270 ohms, 2 watt	RC-42-BF-271-K
R99	Fixed: 22 ohms, 2 watt, $\pm 20\%$	RC-42-BF-220-M
R100	Fixed: 150 ohms, 7 watt	B-17436-7
R101	Fixed: 2300 ohms, 10 watt, wire-wound	B-17436-6
R102	Fixed: 2.2 ohms, 1 watt, wire-wound	K-098-24
R103	Fixed: 3.9 ohms, 1 watt, wire-wound	K-098-33

*All resistors 1/2 watt, 10% tolerance
unless noted otherwise.

PARTS LIST (CONT'D)

MISCELLANEOUS

SYM-BOL	DESCRIPTION	NATCO TYPE
CR1	Rectifier, Silicon Diode	1N1692
F1	Fuse: 2 amps, 250 v	A-13806-1
I1	Lamp, Panel: 0.15 amps, 6.3 v	NPL-47
I2	Same as I1	
I3	Same as I1	
J1	Connector, Coaxial: (Ant.) AMPH. UHF 83-1R	B-27680
J2	Same as J1 (IF)	
J3	Same as J1 (HFO)	
J4	Jack, Phones:	A-12241
L1	RF Choke: 10 microhenries	SA-3001
L2	RF Choke: 2. millihenries	SA-3080
L3	Inductor, Variable: Band 1	B-25857
L4	Inductor, Variable: Band 2	B-25858
L5	Inductor, Variable: Band 3	B-25859
L6	Inductor, Variable: Band 4	B-25860
L7	Inductor, Variable: Band 5	B-25861
L8	Inductor, Variable: Band 6	B-25862
L9	Inductor, Variable: Band 7	B-25863
L10	Choke: 1.1 microhenries	SA-3992
L11	Inductor, Variable: 0.9 microhenries	B-20671
L12	Same as L10	
L13	Same as L10	
L14	Same as L2	
L15	Choke, Filter: 4 henries	B-20788
M1	Meter, S: 0-1 ma.	C-25545
P1	Socket, Crystal	SB-2813
PIA	Plug, Cathode	B-20682

SYM-BOL	DESCRIPTION	NATCO TYPE
P2	Socket, Accessory	B-27674-2
P2A	Plug, Accessory	A-27620
P3	Socket, Calibrator: Same as P2	
P4	Plug, Crystal Filter Input	
P5	Plug, Crystal Filter Output	
S1	Switch, BAND	
S2	Switch, OSC Channel Selector	
S3	Switch, IF Selector	
S4	Switch, MODE	
S5	Switch, TONE	B-20674
S6	Switch, On/OFF: Part of R92	
S7	Switch, 115 v 230 v line	B-27662
S8	Switch, STBY/REC	B-27663
S9	Switch, CALIBRATE	B-25541
T1	Coil, Antenna: Band 1	B-25871
T2	Coil, Antenna: Band 2	B-25872
T3	Coil, Antenna: Band 3	B-25873
T4	Coil, Antenna: Band 4	B-25874
T5	Coil, Antenna: Band 5	B-25875
T6	Coil, Antenna: Band 6	B-25876
T7	Coil, Antenna: Band 7	B-25877
T8	Coil, RF: Band 1	B-25864
T9	Coil, RF: Band 2	B-25865
T10	Coil, RF: Band 3	B-25866
T11	Coil, RF: Band 4	B-25867
T12	Coil, RF: Band 5	B-25868
T13	Coil, RF: Band 6	B-25869
T14	Coil, RF: Band 7	B-25870

PARTS LIST (CONT'D)

MISCELLANEOUS (CONT'D)

SYM-BOL	DESCRIPTION	NATCO TYPE
T15	Coil, Mixer: Band 1	B-25850
T16	Coil, Mixer: Band 2	B-25851
T17	Coil, Mixer: Band 3	B-25852
T18	Coil, Mixer: Band 4	B-25853
T19	Coil, Mixer: Band 5	B-25854
T20	Coil, Mixer: Band 6	B-25855
T21	Coil, Mixer: Band 7	B-25856
T22	Transformer, IF: 1720 kc	SA-9122
T23	Transformer, IF: 455 kc	B-20672
T24	Transformer, IF: 455 kc	SA-9123
T25	Same as T24	
T26	Same as T24	
T27	Transformer, IF: 455 kc	SA-5343
T28	Same as T24	
T29	Same as T24	
T30	Same as T27	
T31	Same as T24	
T32	Same as T24	
T33	Transformer, IF	B-25078
T34	Transformer, Audio Output	B-20649
T35	Transformer, Power	B-20789
TB1	Panel, Terminal, BSW	B-20681-3
TB2	Panel, Terminal, Audio	B-20681-2
TP1	Jack, Tip IFO: Amph. 78-1P	B-27664-1

SYM-BOL	DESCRIPTION	NATCO TYPE
TP2	Jack, Tip BFO: Amph. 78-1P	B-27664-1
V1	Tube: type 6BZ6	
V2	Same as V1	
V3	Tube: type 6BE6	
V4	Same as V3	
V5	Same as V3	
V6	Tube: type 6BZ7	
V7	Tube: type 6BA6	
V8	Same as V7	
V9	Same as V7	
V10	Tube: type 6AL5	
V11	Same as V3	
V12	Tube: type 6U8	
V13	Same as V10	
V14	Tube: type 12AT7	
V15	Tube: type 6AQ5	
V16	Tube: type 5U4GB	
V17	Tube: type 0B2	
V18	Tube: type 4H4C	
Y1	Crystal, Quartz: 1275 kc	B-20670
Y7	Crystal, Quartz: 455 kc	B-19815-2
YX1	Socket, Crystal	SB-2813
YX2	Same as YX1	
YX3	Same as YX1	
YX4	Same as YX1	
YX5	Same as YX1	
YX6	Same as YX1	

CODE #S-5U4

NOTE: This Silicon Rectifier Tube Replacement has a negligible voltage drop based upon an impedance of less than 10 ohms. To limit the output voltage to the same as that obtained with the vacuum tube being replaced and protect against surge currents, insert in series with the center tap of the secondary of the power transformer the following resistor:

When replacing Tube Type	Use following Resistor (in ohms)	Suggested Wattage Rating
5AS4	21	25
5AU4	30	10
5AW4	153	5
5T4	150	10
5U4G	170	10
* 5U4GB	21	25
5V4GA	100	5
5V4G	100	5
5W4	50	1
5W4GTG	50	1
5Y3	50	2
5Y3GT	50	2
5Z4	50	2

MAXIMUM RATINGS

Max. DC output current per section 225 ma.
 Peak inverse voltage per section 1550 volts.
 Peak recurrent current per section 1.1 amp.
 AC anode supply voltage
 (RMS) per section (F.W. Center Tap) 550 volts.

SPECIFICATIONS (per section)

Max. forward voltage drop @ 400 ma, DC 6.0 volts.
 Max. inverse current @ 1550 VDC 2.5 uAmp.

BASE DIAGRAM (Bottom View)

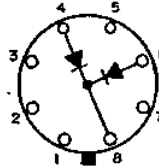

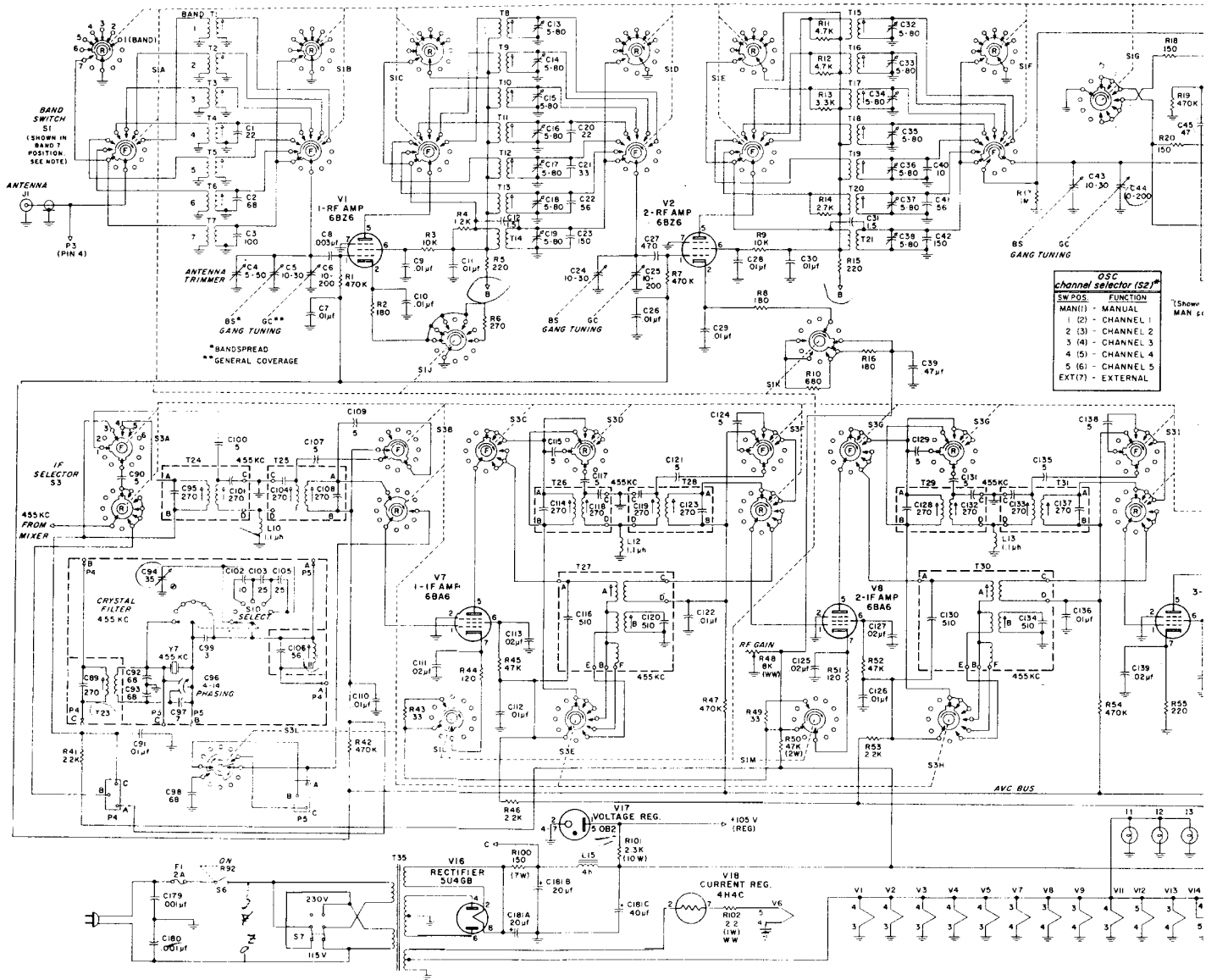

BAND SWITCH S1
(SHOWN IN BAND 1 POSITION. SEE NOTE)

* BANDSPREAD
** GENERAL COVERAGE

GANG TUNING

(SHOW MAN...)

455 KC FROM MIXER

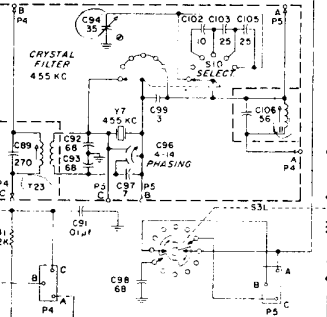

AVC BUS

V17 VOLTAGE REG.

V18 CURRENT REG.

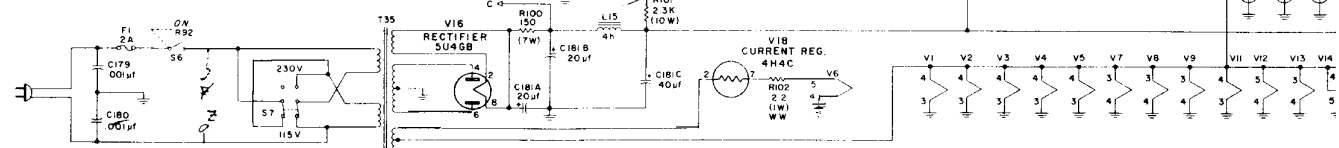

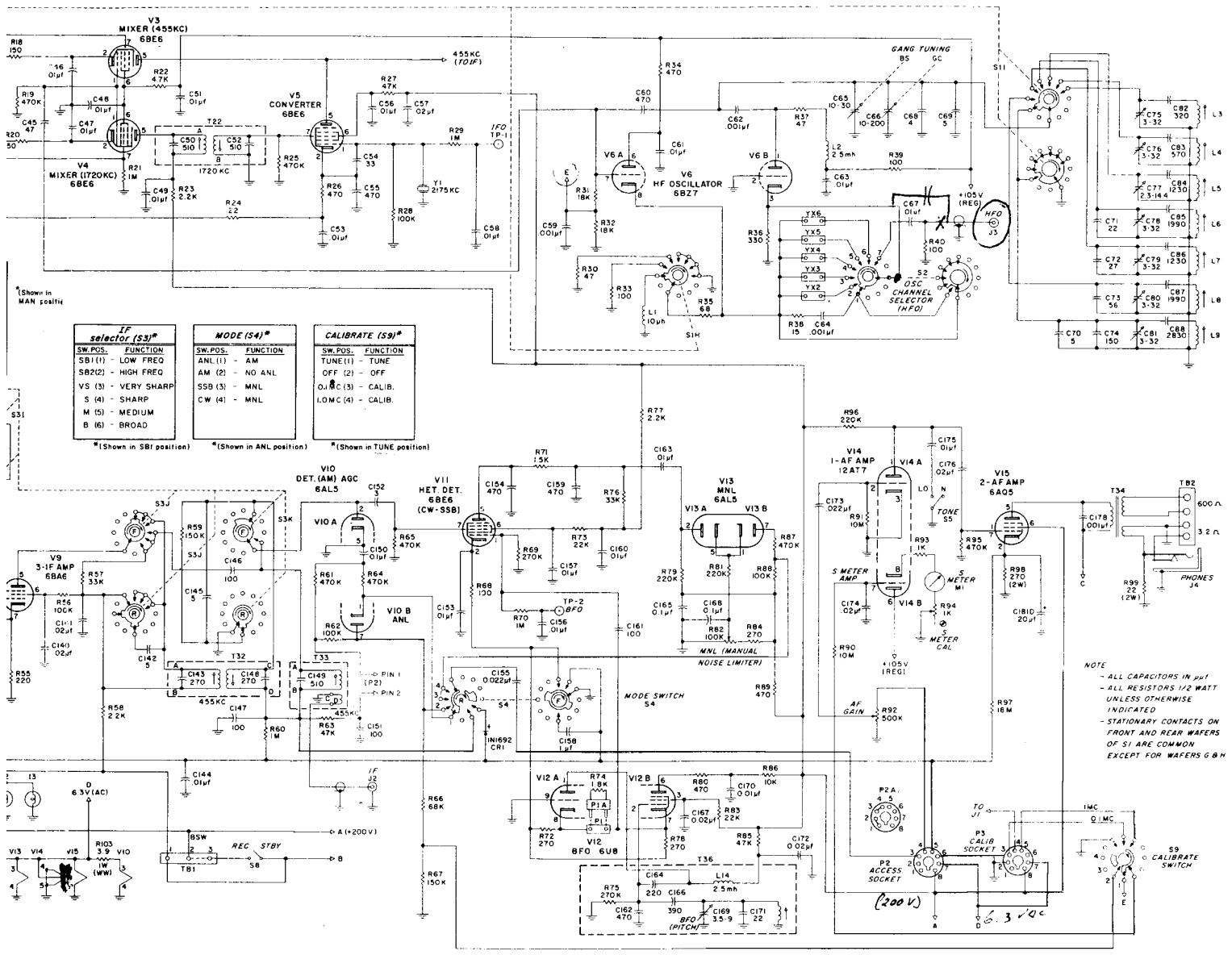

IF selector (S3)*		MODE (S4)*		CALIBRATE (S9)*	
SW. POS.	FUNCTION	SW. POS.	FUNCTION	SW. POS.	FUNCTION
SB1 (1)	LOW FREQ	ANL (1)	AM	TUNE (1)	TUNE
SB2 (2)	HIGH FREQ	AM (2)	NO ANL	OFF (2)	OFF
VS (3)	VERY SHARP	SSB (3)	MNL	0.1 R.C. (3)	CALIB.
S (4)	SHARP	CW (4)	MNL	LOMC (4)	CALIB.
M (5)	MEDIUM				
B (6)	BROAD				

NOTE - ALL CAPACITORS IN μF UNLESS OTHERWISE INDICATED - STATIONARY CONTACTS ON FRONT AND REAR WAFERS OF S1 ARE COMMON EXCEPT FOR WAFERS G & H

TABLE OF CONTENTS

Title	Page
Section 1 DESCRIPTION	
1.1 General	1
1.2 Circuit Description	2
1.3 Accessories	5
Section 2 INSTALLATION	
2.1 Unpacking	6
2.2 Preparation for Use	6
2.3 Accessories	7
Section 3 OPERATION	
3.1 General	8
3.2 Controls	8
3.3 Modes of Operation	11
3.4 Accessory Crystals	12
Section 4 MAINTENANCE	
4.1 General	13
4.2 Trouble-shooting	13
4.3 Voltage Measurements	13
Section 5 ALIGNMENT	
5.1 General	16
5.2 Instruments	16
5.3 IF Alignment	16
5.4 RF Alignment	17
Section 6 ACCESSORIES	
6.1 Crystal Calibrator Unit (XCU-400)	20
6.2 Mechanical Filter Housing	21
6.3 Diversity Modification Kit	23

LIST OF ILLUSTRATIONS

Figure	Page
1 Block Diagram NC-400	3
2 IF Selectivity Curves	4
3 Audio Response	5
4 Rear Chassis Panel	7
5 Panel Control Locations	9
6 Tube Locations and Alignment Adjustments.....	14
7 Voltage Measurements	15
8 Alignment Chart	18
9 Alignment Adjustments (Bottom Chassis)	19
10 Schematic, XCU-400 Crystal Calibrator	21
11 Schematic, MFH Mechanical Filter Housing.....	23

NATIONAL NC-400

COMMUNICATIONS RECEIVER

SPECIFICATIONS

FREQUENCY RANGE

Band 1	0.54 to 1.1 mc
Band 2	1.1 to 2.1 mc
Band 3	2.1 to 4.1 mc
Band 4	4.1 to 7.0 mc
Band 5	6.9 to 12.2 mc
Band 6	11.8 to 20.4 mc
Band 7	19.6 to 31.0 mc

TYPE OF RECEPTION

AM, SSB, and CW

SENSITIVITY

Approximately 1 uv for 10 db signal-noise ratio

FREQUENCY STABILITY

Long term drift .002% after warmup

RF INPUT

Single-ended coaxial, 52 ohm with antenna trimmer.

AUDIO OUTPUT

Impedance 3.2 and 600 ohms, 1 watt, distortion less than 10%.

POWER REQUIREMENTS

115/230 volts ac 60 cycle, 138 watts.

ACCESSORIES

Crystal Calibrator (plug-in) for 100 kc and 1 mc. Panel switch selection.

Diversity Modification Kit

Mechanical Filter Housing (plug-in)

Plug-in crystals (5) for fixed channel HF oscillator control

Plug-in crystal for BFO control

IMAGE REJECTION

Band 1	100 db (or more).
Band 2	100 db
Band 3	85 db
Band 4	65 db
Band 5	95 db
Band 6	90 db
Band 7	80 db

SELECTIVITY (IF)

16 kc to 150 cycles with crystal filter.

Broad	16 kc
Medium	8 kc
Sharp	4 kc
Very Sharp	{ 3.5 kc to 150 cy using crystal filter
SSB	{ 3.5 kc (at 6 db down) 10.0 kc (at 60 db down)

TUBE COMPLEMENT

6BZ6	1st RF amplifier
6BZ6	2nd RF amplifier
6BE6	1st Mixer (455 kc)
6BE6	1st Mixer (1720 kc)
6BE6	2nd Converter/oscillator
6BZ7	HF oscillator
6BA6	1st IF amplifier
6BA6	2nd IF amplifier
6BA6	3rd IF amplifier
6AL5	AM detector/ANL
6BE6	Heterodyne detector
6AL5	Manual noise limiter
6U8	BFO
12AT7	1st AF/S-meter amplifier
6AQ5	Audio output
4H4C	Filament current regulator
OB2	Voltage regulator
5U4GB	Rectifier

NOTE: Matching loud-speaker available