

Model 4350A Receiver



RME

Electro-Voice[®]

RME DIVISION • ELECTRO-VOICE, INC. • BUCHANAN, MICHIGAN

TABLE OF CONTENTS

GENERAL DESCRIPTION

Introduction	Page 3
Description	3
Frequency Coverage	3
Figure 1, Top Chassis Layout	3
Speaker Impedance	3
Power Source	3
Antenna Input Impedance	3
Electrical Specifications	4
Controls	4
Tube Complement	4
Dimensions	4
Weight	4
Figure 2, Front Panel Layout	4

INSTALLATION AND OPERATION

Unpacking	5
Rear Chassis Connections	5
Antenna Connection	5
Single-wire Antenna Diagram	5
Doublet Antenna Diagram	5
Operation Procedure	5
Figure 3, Rear Chassis Connections	5
S-meter	6
CW Telegraph Operation	6
Automatic Noise Limiter	6
100 KC Crystal Calibrator	6
Calibrate Control	6
Headphone Operation	6
Use of Crystal Filter	6
Single Sideband Suppressed Carrier Reception	6
Single Sideband Adapter, RME 4301	7

MAINTENANCE

Alignment	7
Alignment of RF Circuits	7
Crystal Phasing Adjustment	8
S-meter Adjustment	8
Warranty	8
Tube Voltage Chart	9
Parts List	9
Schematic Diagram	10

INTRODUCTION

The material and information compiled in the following pages has been assembled for the purpose of providing the user of an RME 4350A receiver with information which will acquaint him with the communication performance and operation of the instrument. Most questions which arise in connection with the use of the receiver will be answered in these pages. Correct procedures for adjustment during operation and for service purposes are presented. The instructions should be read carefully before using the instrument.

GENERAL DESCRIPTION

The RME 4350A is a receiver designed for the amateur communication bands in the frequency range of 1750 kc to 30 mc. The receiver provides facilities for the reception of CW, MCW, AM phone and SSBSC. It employs seven multi-purpose tubes doing the work of eleven individual tubes. It also employs a vacuum tube rectifier, a voltage regulator tube and a 100 kc oscillator tube. A view of the top chassis layout, Fig. 1, gives the position of the top adjusted circuit components, referenced in the portion of these instructions applying specifically to servicing of the instrument.

The circuit employs a tuned radio-frequency amplifier stage followed in order by a tuned detector, oscillator, crystal controlled 1st mixer, crystal filter, two high-selectance second IF amplifier stages, a combination second detector, ANL stage and audio voltage amplifier, and a power audio output amplifier. The second IF amplifier tube is a multi-purpose tube which provides elements for use in a beat frequency oscillator circuit to provide for CW and single sideband suppressed carrier receptions.

The power output is supplied from a 4-ohm winding for direct connection to the matching RME 4302 speaker or a standard radio receiver dynamic speaker. Receiver input power requirements are 117 volts; 65 watts, at 50/60 cycles, alternating current only.

The receiver is designed for continuous operation in room temperatures up to 100°F. and is temperature compensated to provide stable operation relative to constant ambient temperature after approximately twenty minutes of warmup. The average initial drift is given in the general specifications.

A frequency correction control is brought out on the panel for the purpose of setting the frequency exactly at any scale point. An antenna trimmer is provided for peaking the antenna input tuned circuit to exact resonance with practically any type of connected antenna. The antenna input impedance is normally 300 ohms and will be subject to some variation with frequency, performing satisfactorily with antennas in the impedance range of 50 to 600 ohms.

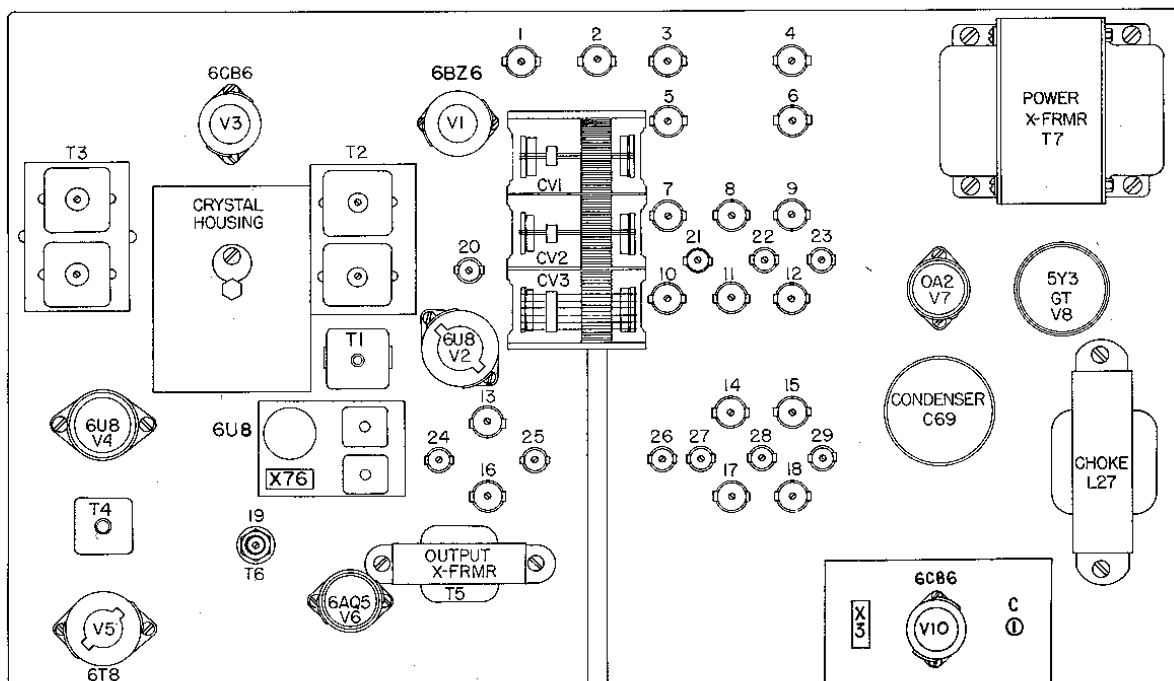

TRIMMER & COIL
ADJUSTMENT LOCATIONS

BAND	1	2	3	4	5	6
ANTENNA INDUCTOR	6	4	5	3	1	2
MIXER INDUCTOR	12	9	11	8	10	7
MIXER CAPACITOR	23	22	21	21	21	20
OSCILLATOR INDUCTOR	18	15	14	17	16	13
OSCILLATOR CAPACITOR	29	28	27	26	25	24

BFO FREQ. ADJ. - 19

Fig. 1— Top Chassis Layout

SPECIFICATIONS

Sensitivity: 2 microvolts 30% modulation for 100 mw output

Signal-to-Noise Ratio: 10 db at 2 microvolts input (30% modulation)

Audio Output: 1.5 watts
Calibration: .02%

Frequency Drift: .01%

Selectivity:
(without crystal filter)

Band Width: 2.8 kc 14 kc
Attenuation: 0 db 60 db

Notch Rejection:
(with crystal filter) 35 db

S-Meter Calibration: S1 to S9 (6 db steps)
plus 10 db units over S9

IF Frequency 1st IF 2195 KC
2nd IF 455 KC

Image Ratio: Not less than 54 db on any band

Frequency Range:

Range 1: 1.8 — 2 mc
Range 2: 3.5 — 4 mc

Range 3: 7 — 7.3 mc
Range 4: 14 — 14.35 mc
Range 5: 21 — 21.5 mc
Range 6: 26.95 — 29.7 mc

Tuning Control Ratio: 75:1 and 1:1

Input Requirement: 117 V—50/60 cycle AC

Power Input 65 watts

Transmit Switch 115 V — 1 amp

Tubes:

Total of 10 as follows:

- V1 6BZ6 RF amplifier
- V2 6U8 1st mixer
- V3 6CB6 1st IF amplifier
- V9 6U8 2nd mixer
- V4 6U8 2nd IF amplifier—BFO
- V5 6T8 2nd Det—ANL—1st AF
- V6 6AQ5 AF output
- V8 5Y3 Rectifier
- V7 OA2 Voltage regulator
- V10 6CB6 100 KC crystal oscillator

Controls:

- a. Tuning, dual speed
- b. AF gain level
- c. BFO pitch
- d. BFO injection
- e. Antenna trimmer *
- f. Calibration adjust
- g. Band selector switch
- h. RF gain control—line switch
- i. Function switch
MGC-BFO
AGC-AM phone
AGC-SSB
MGC-SSB
- j. Stand-by—receive—transmit
- k. Crystal filter selectivity selector
- l. Crystal filter phasing—rejector
- m. ANL—ON—Off switch
(See Fig. 2)
- n. 100 KC calibrator on-off
- a. Antenna input—doublet and Marconi
- b. External control terminals
- c. Relay control terminals
- d. Single sideband selector jacks
- e. Speaker terminals—for 4-ohm voice coil speaker

External Connections:
(Rear chassis)

Dimensions:

16½ in. wide x 10 in. deep x 10 in. high

Weight:

32 lb net, 36 lb shipping

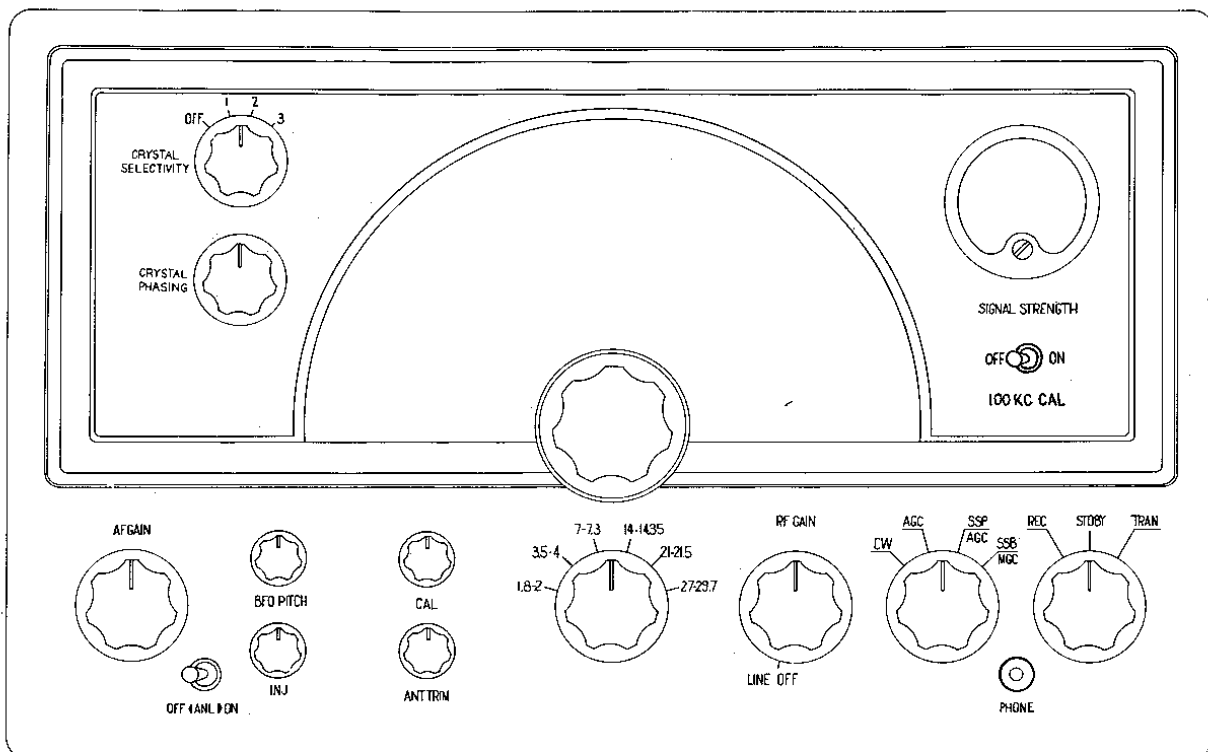

Fig. 2 — Front Panel Layout

INSTRUCTIONS FOR SET-UP AND OPERATION

Immediately upon unpacking the amplifier carefully inspect it for physical damage. If damage is evidenced, notify the dealer from whom the unit was purchased, or the transportation company if the unit was shipped to you. Responsibility for shipping damage lies with the carrier and claim should be made for recovery.

REAR CHASSIS CONNECTIONS—

SPKR Speaker

R Transmit-standby relay circuit

B Receive-standby

G Antenna ground

A } Antenna
A }

Red jack Single sideband adapter

White jack Single sideband adapter, IF

The lower left connector strip is normally connected with B jumper (See Fig. 3) when it leaves the factory. The receiver will not operate without this circuit being closed either with the jumper as shown or with another closed circuit, such as a pair of closed switch or relay contacts. The receiver is muted by opening this circuit.

The terminals R are connected to a switching circuit, closed when the stand-by switch is in position, marked "trans." (See Fig. 2). The circuit will switch a 117 V, 0.5-amp relay circuit or a 117 V, 1.0 amp noninductive circuit for transmitter control. No power is supplied in this circuit. It is merely a make-break circuit.

The receiver leaves the factory test department with jumper between G-A. If single-wire antenna is used, the connection should be as below:

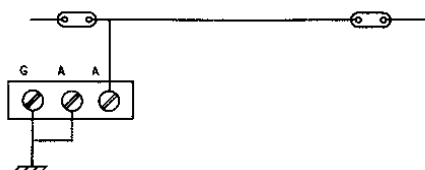

Suggested all-purpose antenna; length is 75 feet including lead-in. The major portion should be 30 to 40 feet above ground. If coaxial antenna lead is used connect the center lead to A and the shield to A-G. Leave jumper connected.

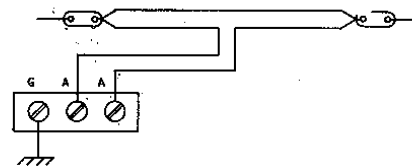

A doublet antenna can be used and connections are made as shown above. The entire antenna and lead-in is made from 300-ohm television transmission line. The horizontal portion of the dipole should be $\frac{1}{2}$ wavelength long for center of the band to be used. The transmission line can be any convenient length.

Two jacks are provided on the right-hand side of the rear chassis (See Fig. 3) for quick and complete interconnection of the RME 4350A receiver and the RME 4301 single sideband selector. The jacks are color coded as are the plugs on the sideband selector and should be mated for color when interconnecting. The "red" jack is an audio input circuit connection and the "white" jack is the IF input circuit connection to the selector from the receiver. The schematic diagram shows the exact circuitry.

OPERATION PROCEDURE — After unpacking the receiver and determining that all packing materials have been removed from the cabinet interior, and that all tubes are properly seated, place the instrument in its operating position and set the following controls as indicated:

AF Gain Control	50% rotation
ANL Switch	OFF
Ant. Trim	Pointer straight up
Cal Adj.	Should arrive from factory in "straight-up position"
Band Selector	Position 1 (1.8—2 mc)
RF Gain-Line	OFF
Function Switch	AGC
Stand-By Switch	Std-By
Crystal Selectivity	OFF
100 KC Calibrator	OFF

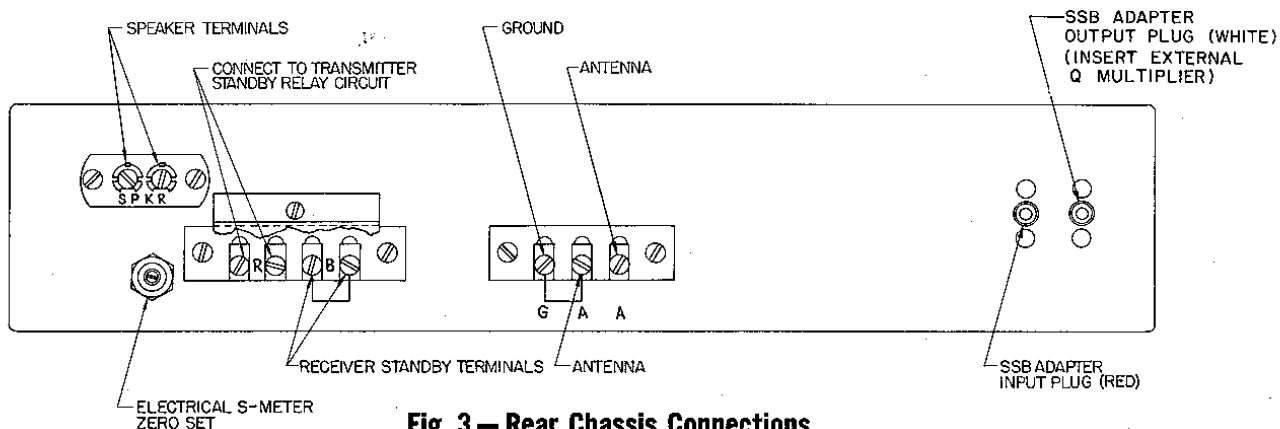

Fig. 3 — Rear Chassis Connections

Next connect the RME 4202 speaker or a suitable substitute with 4-ohm voice coil to the speaker terminals (See Fig. 3). The power supply plug may now be plugged into the source (117 V—50/60 cycle AC). Now connect a suitable antenna, (See preceding page) and rotate RF-gain control to full clockwise position. After a minute or so, set stand-by switch to "Rec" and the receiver will come to life as evidenced by atmospheric background noise and/or signal. The S-meter should read around "O" if no signal is being received and if ambient electrical noise is not unusually high. If the meter reads up without signal and in the absence of abnormal noise, disconnect the antenna momentarily, switch band selector to 28 mc band and with controls maintained in the suggested position (especially max. clockwise for RF gain), set the S-meter to "O" by means of the meter balance control (C) on the rear apron of the chassis (See Fig. 3). When this has been done, the antenna may be reconnected and the band selector switch restored to a desired frequency band.

If, without signal, the meter reads up a slight amount on any other band, it is of no consequence since it is measuring received noise and should not be zeroed again. The meter reading will be accurate only when the RF-gain control is in maximum position. S9 is the meter reading obtained when approximately 100 microvolts of signal is introduced across the antenna terminals. This value is subject to 50% change due to variation in circuit components. For each band selected the "Ant. Trim" control should be adjusted to maximum meter reading or maximum receiver output. As there may be slight variations between bands, especially with different types of antennas, the control should always be peaked for the signal being received.

The tuning control has two ratios, 1:1 and 75:1. Quick change of tuning to any region of any band can be achieved on the direct-coupled control (rear knob) and then a vernier type of tuning is possible by adjusting the front knob. The high ratio can be used as desired since it is effective over the entire tuning excursion of the pointer. The tuning is smooth, uniform and easily accomplished.

CW TELEGRAPH RECEPTION — Tuning for CW follows the same procedure as above except the function switch is set to CW and INJ control set at 50% rotation. Set the BFO pitch control so it produces a pleasing sound. This adjustment should be made after the signal is in exact tune. Since AGC is switched out, the receiver may easily overload unless the RF gain control is used judiciously. It should be set at a point which will give just adequate sensitivity and the AF gain control should be carried at a point about $\frac{3}{4}$ maximum. Overloading of the receiver due to the signal when the RF gain control is set too high and the AF gain control too low, will result in a blocking effect producing a poor note on the received signal and degraded spacing of the transmitted signal pulses. The injection control should be set at the point giving most pleasing ratio of received signal to noise. Usually the injection of the BFO voltage is reduced for weaker signals. Strong signals will need greater amounts of injection. A slight variation in BFO pitch will result with variation of the injection control. Interference to CW reception can be minimized by selecting the proper side-band of the CW mixer. Rotate the BFO pitch knob slightly to the right or left to determine where the interference is reduced. The pitch of the BFO will vary during this adjustment.

AUTOMATIC NOISE LIMITER (ANL) — The automatic noise limiter is usually effective only in signals received under AGC conditions and with the AF gain control set to some position less than maximum for most noticeable effects. Ignition pulses and similar "popping" types of interference are effectively reduced when using the ANL circuit. It can be switched on and off at will by means of the panel switch provided. Experience will dictate its best employment.

CALIBRATE CONTROL—The calibrate control CAL is used to set the receiver on an exact frequency. More than ± 10 kc adjustment (min) can be effected by adjusting this control, but all bands will be varied by its adjustment. If deviation of calibration occurs on only one band, the proper procedure would be to make a service type adjustment to only the band which has changed.

100 KC CRYSTAL CALIBRATOR — The RME 4350A receiver is equipped with a 100 KC crystal calibrator. The crystal calibrator was accurately adjusted at the factory and should not require further adjustment.

Should it be necessary to recalibrate the 100 KC oscillator, use another receiver that will tune WWV. Run a piece of wire from antenna terminal No. 3 of the 4350A to the antenna terminal of the second receiver tuned to WWV. Be sure that both receivers have been turned on for at least one-half hour.

Lift the top lid of the 4350A. The 100 KC calibrator is located on the chassis just to the left of the S-meter. Using a screwdriver, adjust the trimmer on top of the calibrator chassis. A very slight adjustment should bring the oscillator in zero beat with WWV.

HEADPHONE OPERATION — A jack is provided on the panel for the insertion of a standard headphone plug. The headphone impedance should be greater than 1000 ohms, but the circuit will provide only slightly reduced performance with headsets as low as 200 ohms. The speaker is muted whenever a plug is inserted in the headphone jack marked PHONE.

USE OF CRYSTAL FILTER — The electro-mechanical filter employing a quartz element built into the Model 4350A receiver is used for single signal reception. The filter has 3 degrees of selectivity increasing with clockwise rotation of the selectivity selector switch (position 3); maximum counter-clockwise rotation (off) switches the filter out of the receiver circuit. When the filter is used, more care in tuning will be required for best reception since receiver tuning adjustment becomes more critical as the high selectivity of the filter comes into use.

The crystal filter provides two aids to selectivity. When the crystal function switch is turned to position one, two or three a series mechanical resonator provides additional selectivity, the maximum selectivity being in position three. The phasing control is then rotated to the minimum noise position which indicates maximum selectivity. Due to the very sharp selectivity the crystal filter is most effective on CW. When interference occurs in phone operation, set the function switch to position one and tune the signal to maximum S-meter reading. If heterodynes still occur, adjust the phasing control until they are reduced or eliminated. Due to the sharpness of the selectivity curve, the quality of the audio will suffer, as only a few hundred cycles of audio

will be passed. In position two and three, very little of the audio spectrum will be passed, therefore, these positions are not recommended for phone operation. In crystal filter operation, always have your signal peaked with the tuning control. A little practice with the crystal filter will pay dividends in interference free reception.

When using the crystal filter during CW telegraph reception, a faint ringing or pinging sound will be heard, even in the absence of a signal. This ringing sound will vary as the BFO pitch control is varied. The exact pitch of the ringing sound will be the pitch that all CW telegraph signals will have when they are in optimum tune and at the point of maximum receiver sensitivity (maximum crystal filter passband gain).

SSBSC RECEPTION USING RME 4350A ALONE—In order for a receiver to properly reproduce the information transmitted by a single sideband suppressed carrier signal, it must possess these characteristics: (1) Adequate beat-frequency oscillator injection voltage to the second detector. (2) High stability in both the BFO and especially in the heterodyne oscillator. These two characteristics are taken care of adequately in the Model 4350A receiver. Though superior reception results with the use of a single sideband adapter, such as the RME Model 4301 single sideband selector, the receiver alone can be a satisfactory device for a single sideband suppressed carrier reception.

This type of reception demands that a carrier whose frequency is close (± 20 cycles) to that of the original carrier of the transmitted signal—which carrier has been suppressed—must be inserted at the second detector for demodulation purposes. By setting the receiver function switch to CW, adjusting the level of the RF gain and tuning of the receiver, single sideband suppressed carrier signals, usually referred to as SSBSC signals, can be adjusted to perfect reception conditions. If lower sideband signals are being transmitted, the BFO of the receiver can be adjusted so that its frequency is near one edge of the passband of the receiver (the upper edge) and the full passband can be used for the reception of the signal in a manner which will exclude all signals at frequencies in the vicinity of the upper sideband. The reverse can be accomplished if the BFO is shifted to the other edge (the lower edge) of the receiver passband. The transmission is made to contain only the upper sidebands.

During the reception of SSBSC signals, the same precautions relative to RF gain control level must be observed that were recommended for CW reception. That is, the level must always be carried below any possible RF or IF amplifier overload point otherwise the intelligibility of the signal will be greatly degraded.

Because of the fact that on band 6 (10 meters) the heterodyne oscillator is operating at a frequency lower than the signal, the frequency of the BFO will have to be adjusted in opposite manner to that described in the foregoing paragraph relative to upper and lower sideband reception.

Using the receiver alone, only manual gain control is provided for SSBSC reception. It will be entirely adequate and capable of high performance under these conditions.

SSBSC RECEPTION USING THE RME MODEL 4301 SELECTOR—The combination of the Model 4301 with the Model 4350A receiver provides exceptional performance in SSBSC reception. Upper, lower or double sideband reception is provided at the turn of a switch. This switch also can restore the combination to normal operation. The connection between the units is made by means of cables, plugs and jacks provided with the unit. The receiver is switched to the combination condition by means of the panel function switch and either the MGC-SSB or the AGC-SSB position may be used. When tuning, the double sideband position of the selector switch on the 4301 should be used. When a signal is found, the selector switch may be placed in either sideband 1 or sideband 2 position as may be required on the transmitted signal. When either of these two positions are used, the apparent selectivity is doubled because all the signal material on the unused sideband is reduced in response 40 db below the desired sideband portion of the spectrum. It is absolutely essential that the BFO in the 4301 be adjusted to a frequency which is in the center of the 455 KC 2nd IF channel of the 4350A receiver.

A trimmer condenser adjustment for the BFO in the SSB selector is located on the panel and runs normally in a "straight-up" position. Slight variations (up to 30% rotation in either direction) from this position may be made for vernier adjustment of the frequency of the inserted carrier. Maximum unwanted sideband rejection will be obtained when it is "straight up."

ALIGNMENT

Second Intermediate Frequency — 455 KC

Alignment of IF amplifier is easily achieved using the crystal filter and the receiver S-meter. Proceed as follows:

1. Set function switch to AGC.
2. Set band switch to band 1 (1.8 to 2.0 mc).
3. Connect signal generator output to center stator of tuning capacitor.
4. Set crystal filter selectivity switch to position 2 or 3.
5. With relatively high signal input from signal generator, sweep signal generator frequency around 455 KC till a sharp upward kick of the S-meter is noted. Carefully adjust signal generator frequency control until the meter reading is maximized. Cut back on signal generator out-

put to keep receiver S-meter reading about mid-scale for all measurements.

6. With signal generator frequency set at the value giving maximum S-meter reading, the crystal filter selectivity switch may be switched off, and each IF transformer unit adjusted for maximum S-meter reading. With this done, the amplifier is aligned and adjusted to the proper frequency, that of the quartz plate in the filter.

First Intermediate Frequency — 2195 KC

After the 2nd IF amplifier channel is aligned as just outlined, the 1st IF amplifier can be aligned as follows: Leave the signal generator connected as for the 455 KC IF channel alignment but tune the signal generator to 2195 KC (the 1st IF) and

sweep the frequency control of the signal generator slowly and by only a small amount around this frequency. The 2nd mixer oscillator which is crystal controlled at 2650 KC will beat with this signal to produce 455 KC in the 2nd mixer. When a response to this input signal (2195 KC) is obtained and adjusted by signal generator frequency control to maximum "S" meter reading on the receiver, the 1st IF channel transformers can be adjusted further to maximize the "S" meter reading if they are off the proper setting. This 1st IF channel adjustment involves two coil slug adjustments on each of the two transformers making a total of four adjustments on the 2195 KC 1st IF channel. These last adjustments complete the IF adjustment of the receiver. The adjustments are accessible as follows: two on the 1st mixer subchassis through the tops of the 2195 KC IF cans and two from below the chassis through a rectangular port near the 6U8 1st mixer tube socket beneath the coil section bottom cover plate. It will usually never be necessary to adjust the 2195 KC IF channel unless it has been misaligned by tampering since the factory adjustments are practically permanent and unvarying.

The BFO frequency may be set now by allowing the signal generator to remain at the setting determined just previously, and then setting the function switch to "CW". Set the BFO pitch control knob so that the dot is in the center on top. If the BFO tone is not approximately zero frequency with controls set as suggested, adjust the BFO coil tuner slug 19 (See Fig. 1) for approximately zero frequency beat note, using the unmodulated signal generator or other signal source whose frequency has been set to the center of the IF pass as described above. Note: Make certain that the dot on BFO knob is positioned so that the BFO trimmer condenser is at 50% mesh when the dot is straight up. The BFO operates at 455 KC.

ALIGNMENT OF RF CIRCUITS — The RF circuits and the oscillator circuits are adjusted by means of both iron-core screw adjustments and screw type adjusted capacitors. Usually, no adjustment will be required because of the inherent stability of the components. Generally, the iron-core coil adjustment is

the one to use, although adjustment of the capacitors will also tune the circuits. Their use is reserved for coverage control of the tuning range. Less band coverage will result with increased trimmer capacity of the tuned circuits (this increase results when the adjustment screws are screwed in toward the chassis or as the screw length projecting from the chassis is shortened). Increased band coverage results when these trimmers are reduced in capacity or screwed outward. Very little adjustment is necessary as all circuits are designed with close tolerance fixed trimmers. The amount of variation during the life of the receiver is small and only minor touch up is possible. The oscillator circuits are adjustable in similar fashion and, because the oscillator circuit controls the receiver calibration, only slight adjustment of the oscillator should be made. For complete receiver calibration, the tuning condenser should be fully meshed when the red pointer is at the lower edge of the scale in the counter-clockwise position.

CRYSTAL PHASING ADJUSTMENT — Underneath the chassis between the first and second IF stages is a compression trimmer for centering the phasing control of the crystal filter located on the panel. The shaft of the phasing control, as it comes out of the front of the filter unit, is scored with a line and when positioned straight up, indicates 50% mesh of the phasing condenser. This is the proper position of the shaft when the control knob indicator is straight up. This position should be used for maximum side-frequency rejection when adjusting the under-chassis trimmer in the phasing bridge. Adjust with no signal other than noise with the filter selectivity switch set to position 2 or 3 and the panel phasing control set straight up center. Leave the trimmer adjusted at the position which gives minimum background noise response.

S-METER — Voltage to ground from each terminal of the S-meter when the meter is balanced will be equal and the value will be approximately 1 volt dc.

WARRANTY—The RME Model 4350A receiver is guaranteed against defects in workmanship and materials.

MODEL 4350A RECEIVER — VOLTAGE CHART

SYM.	TUBE	TUBE PURPOSE	PIN NO.								
			1	2	3	4	5	6	7	8	9
V1	6BZ6	R. F. AMP.	0	1.4V DC	3V AC	3V AC	160V DC	105V DC	0	—	—
V2	6U8	1st MIXER	115V DC	0	115V DC	3V AC	3V AC	180V DC	2.2V DC	0	-7to-16 VDC*
V3	6CB6	1st IF	0	115V DC	3V AC	3V AC	160V DC	100V DC	1.2V DC	—	—
V4	6U8	2nd IF BFO	10to28 DC**	0	115V DC	3V AC	3V AC	180V DC	1.4V DC	0	.3to.8 DC**
V5	6T8	2nd DET., AVC, 1st AUD., ANL.	-.5V DC	-.1V DC	-.15V DC	3V AC	3V AC	.5V DC	0	-.3V DC	.75V DC
V6	6AQ5	A. F. OUTPUT	0	12V DC	3V AC	3V AC	185V DC	200V DC	0	—	—
V7	0A2	V.R.	150V DC	0	0	0	150V DC	65V DC	0	—	—
V8	5Y3GT	RECT.	0	240V DC	0	250V AC	0	250V AC	0	240V DC	—
V9	6U8	2nd MIXER	145V DC	0	150V DC	3V AC	3V AC	160V DC	3V DC	0	-4 V DC
V10	6CB6	100KC CALIBRATOR	-22V DC	1.9V DC	3V AC	3V AC	36V DC	30V DC	1.9V DC	—	—

MEASUREMENT CONDITIONS (Values indicated may vary ±15%)

1. Voltages indicated are measured between point indicated and ground (except heater circuits)
2. AC heater voltages are measured between point indicated and pin 6 of V7
3. Voltmeter resistance: DC—20,000 ohms/volt; AC—1,000 ohms/volt
4. Antenna disconnected—no signal tuned—antenna trimmer tuned for minimum set noise

5. R.F. gain control set at maximum gain (maximum clockwise position)
6. Function switch set for AGC
7. Voltage to ground from each terminal of S-meter when meter is balanced will be approximately 1.3V DC
8. All oscillator grid voltages are measured with 2 mh choke at end of VM lead in series with lead

*OSC. grid voltage varies with frequency range

**Present only when BFO is "ON." Variation is controlled by setting of injection control

PARTS LIST

Key	Description	Part No.	Key	Description	Part No.
C1	Capacitor, 10 MMF, $\pm 5\%$, 500 V, Ceramic	42029	R19	Resistor, 150 OHM, $\frac{1}{2}W$, Carbon	4641
C3A	Capacitor, 20 MMF, $\pm 2\%$ N 750, 500 V, Ceramic	42097	R20	Resistor, 47K, $\frac{1}{2}W$, Carbon	4615
C3B	Capacitor, 45 MMF, $\pm 2\%$ NPO, 500 V, Ceramic	42102	R21	Resistor, 10K, $\frac{1}{2}W$, Carbon	4613
C4A	Capacitor, 5 MMF, $\pm 2\%$ N 750, 500 V, Ceramic	42069	R22	Resistor, 680K, $\frac{1}{2}W$, Carbon	46009
C4B	Capacitor, 20 MMF, $\pm 2\%$ N 330, 500 V, Ceramic	42088	R23	Resistor, 47K, $\frac{1}{2}W$, Carbon	4615
C5	Capacitor, 40 MMF, $\pm 2\%$ N 330, 500 V, Ceramic	42103	R24	Resistor, 270K, $\pm 10\%$, $\frac{1}{2}W$, Carbon	4669
C6A	Capacitor, 25 MMF, $\pm 2\%$ N 750, 500 V, Ceramic	42099	R25	Resistor, 120K, $\frac{1}{2}W$, Carbon	4670
C6B	Capacitor, 25 MMF, $\pm 2\%$ NPO, 500 V, Ceramic	42098	R26	Resistor, 47K, $\frac{1}{2}W$, Carbon	4615
C7A	Capacitor, 45 MMF, $\pm 2\%$ N 330, 500 V, Ceramic	42101	R27	Resistor, 330 OHM, $\frac{1}{2}W$, Carbon	4623
C7B	Capacitor, 40 MMF, $\pm 2\%$ NPO, 500 V, Ceramic	42100	R28	Potentiometer, 5 MEG, 2W, Audio Taper, Carbon	C46037
C8	Capacitor, 20 MMF, $\pm 2\%$ NTC 750, 500 V, Ceramic	42097	R29	Resistor, 270K, $\pm 10\%$, $\frac{1}{2}W$, Carbon	4669
C9	Capacitor, 100 MMF, $\pm 2\%$ ZTC, 500 V, Ceramic	42084	R30	Resistor, 120K, $\frac{1}{2}W$, Carbon	4670
C10	Capacitor, 70 MMF, $\pm 5\%$ NPO, 500 V, Ceramic	42065	R31	Resistor, 47K, $\frac{1}{2}W$, Carbon	4615
C11	Capacitor, 50 MMF, $\pm 2\frac{1}{2}\%$, 500 V, Ceramic	42027	R32	Resistor, 2.2K, $\frac{1}{2}W$, Carbon	46042
C13	Capacitor, Adjustable, Air trimmer	42017	R33	Resistor, 1 MEG, $\frac{1}{2}W$, Carbon	46010
C15	Capacitor, .000047 MFD, $\pm 10\%$, 500 V, Ceramic	42022	R34	Resistor, 1 MEG, $\frac{1}{2}W$, Carbon	46010
C16	Capacitor, 0.01 MFD, GMV, 500 V, Ceramic	4252	R35	Resistor, 47K, $\frac{1}{2}W$, Carbon	4615
C17	Capacitor, 0.01 MFD, GMV, 500 V, Ceramic	4252	R36	Potentiometer, 100K, 2W, Linear, Carbon	B46037
C19	Capacitor, Adjustable, Air trimmer	42016	R37	Resistor, 47K, $\frac{1}{2}W$, Carbon	4615
C22	Capacitor, 39 MMF, $\pm 2\frac{1}{2}\%$, 500 V, Ceramic	42028	R38	Resistor, 10K, $\frac{1}{2}W$, Carbon	4613
C23	Capacitor, 0.01 MFD, GMV, 500 V, Ceramic	4252	R39	Resistor, 470K, $\frac{1}{2}W$, Carbon	4650
C24	Capacitor, 0.01 MFD, GMV, 500 V, Ceramic	4252	R40	Resistor, 470 OHM, 1W, Carbon	4643
C25	Capacitor, 0.01 MFD, GMV, 500 V, Ceramic	4252	R41	Potentiometer, 1K, 2W, Linear, Carbon	E46037
C26	Capacitor, 0.01 MFD, GMV, 500 V, Ceramic	4252	R42	Resistor, 68K, 1W, Carbon	46039
C28	Capacitor, 5 MMF, $\pm 5\%$ NPO, 500 V, Ceramic	42075	R43	Resistor, 2.5K, $\pm 5\%$, 5W, Wire-wound	46038
C29	Capacitor, 0.000047 MFD, NTC 750, 500 V, Ceramic	42023	R44	Resistor, 15 OHM, $\frac{1}{2}W$, Carbon	46059
C30	Capacitor, 0.00047 MFD, $\pm 20\%$, 500 V, Mica	42021	R45	Resistor, 820 OHM, $\pm 10\%$, $\frac{1}{2}W$, Carbon	4694
C31	Capacitor, 0.01 MFD, GMV, 500 V, Ceramic	4252	R46	Resistor, 330 OHM, $\pm 10\%$, $\frac{1}{2}W$, Carbon	46040
C32	Capacitor, Part of T-1		R47	Resistor, 15K, $\pm 10\%$, $\frac{1}{2}W$, Carbon	4653
C33	Capacitor, 0.01 MFD, GMV, 500 V, Ceramic	4252	R48	Resistor, 47K, $\pm 10\%$, $\frac{1}{2}W$, Carbon	4615
C34	Capacitor, Adjustable, Trimmer	42025	R49	Resistor, 10K, $\frac{1}{2}W$, Carbon	4613
C35	Capacitor, 0.000047 MFD, $\pm 10\%$, 500 V, Ceramic	42022	R50	Resistor, 10 MEG, $\pm 10\%$, 1W, Carbon	46011
C36	Capacitor, 5 MMF, $\pm 10\%$, 500 V, Ceramic Tubular	42077	R51	Resistor, 150K, $\pm 20\%$, 1W, Carbon	4628
C37	Capacitor, 15 MMF, Air Trimmer	42042	R52	Resistor, 150K, $\pm 20\%$, 1W, Carbon	4628
C41	Capacitor, 10 MMF, $\pm 10\%$, 500 V, Ceramic	4266	R53	Resistor, 680K, $\pm 10\%$, $\frac{1}{2}W$, Carbon	46009
C42	Capacitor, 0.01 MFD, GMV, 500 V, Ceramic	4252	R54	Resistor, 2.7K, $\pm 10\%$, $\frac{1}{2}W$, Carbon	46036
C43	Capacitor, 0.01 MFD, GMV, 500 V, Ceramic	4252	R55	Resistor, 100K, $\pm 10\%$, $\frac{1}{2}W$, Carbon	4695
C44	Capacitor, 0.01 MFD, GMV, 500 V, Ceramic	4252	R56	Resistor, 270K, $\pm 10\%$, $\frac{1}{2}W$, Carbon	4670
C45	Capacitor, 0.01 MFD, GMV, 500 V, Ceramic	4252	R57	Resistor, 120K, $\pm 10\%$, $\frac{1}{2}W$, Carbon	4670
C46	Capacitor, 0.00047 MFD, $\pm 20\%$, 500 V, Mica	42021			
C47	Capacitor, 100 MFD, $\pm 20\%$ NPO, 500 V, Ceramic	42044			
C48	Capacitor, 0.001 MFD, $\pm 10\%$, 500 V, Mica	4284	L1	Coil, 28 MC	E3593
C49	Capacitor, Adjustable, Air trimmer	42017	L2	Coil, 21 MC	D3593
C50	Capacitor, 0.01 MFD, GMV, 500 V, Ceramic	4252	L3	Coil, 14 MC	C3593
C51	Capacitor, 0.01 MFD, GMV, 500 V, Ceramic	4252	L4	Coil, 7 MC	B3593
C52	Capacitor, 10 MMF, $\pm 10\%$, 500 V, Ceramic	4266	L5	Coil, 3.5 MC	A3593
C55	Capacitor, 10 MMF, $\pm 10\%$, 500 V, Ceramic	4266	L6	Coil, 1.7-2 MC	3596
C56	Capacitor, 0.01 MFD, GMV, 500 V, Ceramic	4252	L7	Coil, 28 MC	E3594
C57	Capacitor, 0.01 MFD, GMV, 500 V, Ceramic	4252	L8	Coil, 21 MC	D3594
C58	Capacitor, Part of T-4		L9	Coil, 14 MC	C3594
C59	Capacitor, Part of T-4		L10	Coil, 7 MC	B3594
C60	Capacitor, 0.01 MFD, GMV, 500 V, Ceramic	4252	L11	Coil, 3.5 MC	A3594
C61	Capacitor, 0.000047 MFD, $\pm 10\%$, 500 V, Ceramic	42022	L12	Coil, 1.8 MC	3595
C62	Capacitor, 0.000047 MFD, $\pm 10\%$, 500 V, Ceramic	42022	L13	Coil, 28 MC	F35004
C63	Capacitor, 10 MMF, $\pm 10\%$, 500 V, Ceramic	4266	L14	Coil, 21 MC	E35004
C64	Capacitor, 0.01 MFD, GMV, 500 V, Ceramic	4252	L15	Coil, 14 MC	D35004
C65	Capacitor, 0.01 MFD, GMV, 500 V, Ceramic	4252	L16	Coil, 7 MC	C35004
C66	Capacitor, 0.1 MFD, $\pm 20\%$, 150 V, Paper Tubular	42024	L17	Coil, 3.5 MC	B35004
C67	Capacitor, 0.01 MFD, GMV, 500 V, Ceramic	4252	L18	Coil, 1.8 MC	A35004
C68	Capacitor, 5 MFD, 50 V, Electrolytic	42020	L20	Coil, Part of T2	
C69A			L21	Coil, Part of T2	
C69B	Capacitor, 10-15-15 MFD, 450 V, Electrolytic	42019	L22	Coil, Part of T2	
C69C			L23	Choke, 2.4 MH, Ferrite Core	15018
C71	Capacitor, 0.01 MFD, GMV, 500 V, Ceramic	4252	L24	Coil, Part T3	
C72	Capacitor, 10 MMF, $\pm 10\%$, 500 V, Ceramic	42041	L25	Coil, Part of T3	
C73	Capacitor, 0.000047 MFD, $\pm 10\%$, 500 V, Ceramic	42022	L26	Coil, Part of T3	
C74	Capacitor, 30 MMF, $\pm 10\%$, 500 V, Ceramic	42068	L27	Choke, 12 HY, 80 MA	15015
C75	Capacitor, 39 MMF, $\pm 2\%$, 500 V, Ceramic	42028			
C76	Capacitor, 50 MMF, $\pm 2\frac{1}{2}\%$, TCZ, 500 V, Ceramic	42027	M1	Meter, 2" round, 0-1 MA, 125 OHM	3202
C77	Capacitor, 30 MMF, $\pm 2\%$ NPO, 500 V, Ceramic	42068			
C78	Capacitor, 0.01 MFD, GMV, 500 V, Ceramic	4252	S1	Switch, Part of R2	
C79	Capacitor, 4.7 MFD, $\pm 10\%$, 500 V, Ceramic	4233	S2	Switch, 1 Pole, 4 pos. rotary	5667
C80	Capacitor, 0.01 MFD, GMV, 500 V, Ceramic	4252	S3	Switch, 2 Pole, 3 pos. rotary	5663
C81	Capacitor, 0.01 MFD, GMV, 500 V, Ceramic	4252	S4	Switch, 4 Pole, 4 pos. rotary	5665
C83	Capacitor, 20 MMF, $\pm 10\%$ NPO, 500 V, Ceramic	42092	S5	Switch, SPST, Toggle	5666
C84	Capacitor, 0.01 MFD, GMV, 500 V, Ceramic	4252	S6	Switch, SPST, Toggle	5666
C85	Capacitor, 0.01 MFD, GMV, 500 V, Ceramic	4252	SB	Switch, 10 Pole, 6 pos. rotary	5664
C86	Capacitor, 33 MMF, $\pm 10\%$, 500 V, Ceramic	42093			
C87	Capacitor, 10 MMF, $\pm 5\%$, 500 V, Ceramic	42029	V1	Tube, 6BZ6, RF Amp	4350
C88	Capacitor, 5-25 Variable	42121	V2	Tube, 6U8, Det-Sc	4331
C89	Capacitor, 0.01 mfd, GMV, 500V, Ceramic	4252	V3	Tube, 6CB6, 1st IF	4347
C90	Capacitor, 0.01 mfd, GMV, 500V, Ceramic	4252	V4	Tube, 6U8, 2nd IF-BFO	4331
C92	Capacitor, 5 mmf, $\pm 10\%$, 500V, Ceramic	42077	V5	Tube, 6T8, 2nd Det-AVC-ANL-1st Aud	4332
C93	Capacitor, 250 mmf, $\pm 10\%$, 500V, Ceramic	42153	V6	Tube, 6AW5, AF Out	4333
CA	Capacitor, 1-9 MMF, Ceramic Tubular, Adjustable (10)	42018	V7	Tube, OA2, Volt Reg	4330
CV ₁	Capacitor, Tuning, 3 Gang, Variable	42013	V8	Tube, 5Y3GT, Rect	4314
CV ₂	Capacitor, Tuning, 3 Gang, Variable	42013	V9	Tube, 6U8, Osc	4331
CV ₃	Capacitor, Tuning, 3 Gang, Variable	42013	V10	Tube, 6CB6, 100 KC Osc	4347
R1	Resistor, 270K, $\pm 10\%$, $\frac{1}{2}W$, Carbon	4669	J1	Jack, SSB Adpt. Out	1795
R2	Potentiometer, 15K, 2W, Special Taper, Carbon	A46037	J2	Jack, SSB Adpt. In	1795
R3	Resistor, 150 OHM, $\frac{1}{2}W$, Carbon	4641	J3	Jack, Phone, Closed circuit—one break	17010
R4	Resistor, 47K, $\frac{1}{2}W$, Carbon	4615	T1	Transformer, 455 KC	15011
R5	Resistor, 39K, $\pm 10\%$, 2W, Carbon	4682	T2	Transformer, IF, Interstage	8736
R6	Resistor, 120K, $\frac{1}{2}W$, Carbon	4670	T3	Transformer, IF, Interstage	8736
R7	Resistor, 330 OHM, $\frac{1}{2}W$, Carbon	4623	T4	Transformer, 455 KC	15012
R8	Resistor, 22K, $\frac{1}{2}W$, Carbon	46007	T5	Transformer, Audio, 5000 to 4 OHM, 5W	15014
R9	Resistor, 15K, $\pm 10\%$, $\frac{1}{2}W$, Carbon	46029	T6	Coil, BFO, 125 MH	3598
R10	Resistor, 4.7K, $\frac{1}{2}W$, Carbon	4638	T7	Transformer, Power	15033
R11	Resistor, 2.2K, $\frac{1}{2}W$, Carbon	46042	T8	Transformer, IF, 2 MC	15031
R12	Resistor, 10K, $\frac{1}{2}W$, Carbon	4613	T9	Transformer, IF, 2 MC	15031
R13	Resistor, 68K, $\frac{1}{2}W$, Carbon	46044	X1	Crystal, 455 KC	7139
R14	Resistor, 1 MEG, $\frac{1}{2}W$, Carbon	46010	X2	Crystal, 2650 KC	7142
R15	Resistor, 150 OHM, $\frac{1}{2}W$, Carbon	4641	X3	Crystal, 100 KC	7148
R16	Resistor, 47K, $\frac{1}{2}W$, Carbon	4615			
R17	Resistor, 2.2K, $\frac{1}{2}W$, Carbon	46042	F1	Fuse, 1 $\frac{1}{2}$ A, 3 AG Slo-Blo	20171
R18	Resistor, 1 MEG, $\frac{1}{2}W$, Carbon	46010			

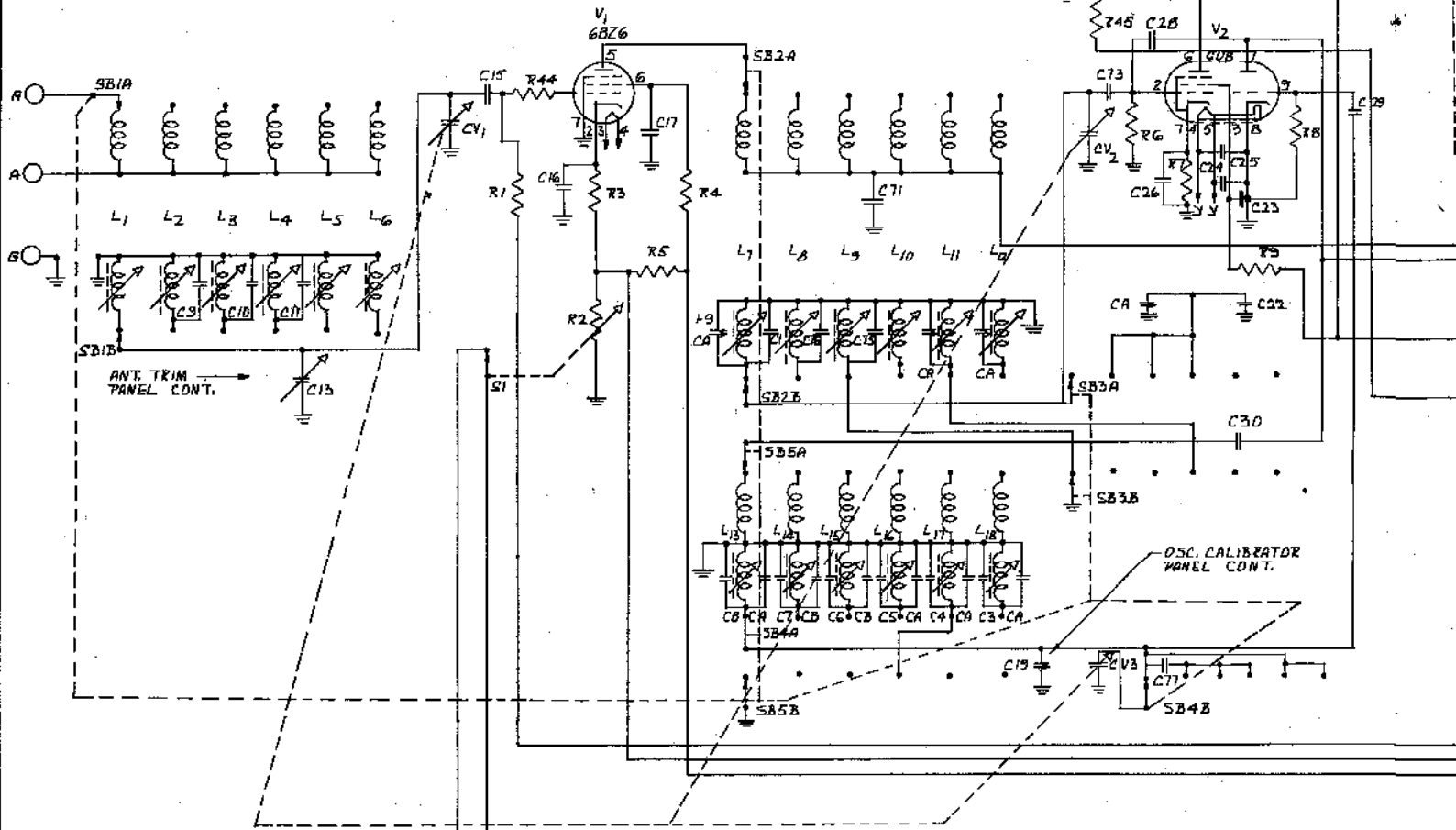
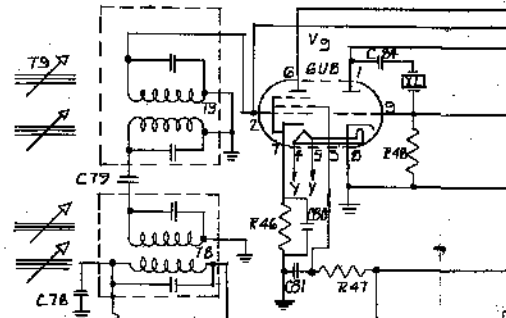
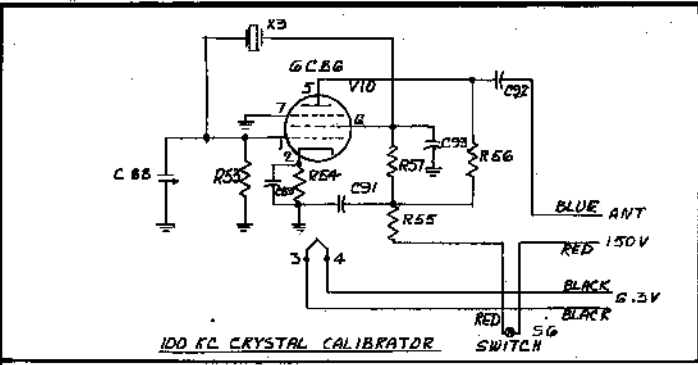

*3R-BAND SWITCH SHOWN
IN 10-4 METER BAND POSITION
(MAX CLOCKWISE POSITION)

- C_A = 1-2 MMFD - CERAMIC ADJ. PAD COND.
- C₁ = 1MFD C₁₁ SPECIAL TEMP COEFFICIENT FIXED CONDENSERS SEE PARTS LIST

- OSC PADDER (I.C. CAPACITORS)
- C₃ 20 MMFD ± 2% NTC 750 + 45 MMFD ± 2% NPO
 - C₄ 20 MMFD ± 2% NTC 750 + 5 MMFD ± 2% NPO
 - C₅ 40 MMFD ± 2% NTC 530
 - C₆ 30 MMFD ± 2% NTC 750 + 2.0 MMFD ± 2% NPO
 - C₇ 30 MMFD ± 2% NTC 530 + 55 MMFD ± 2% NPO
 - C₈ 2.0 MMFD ± 2% NTC 750

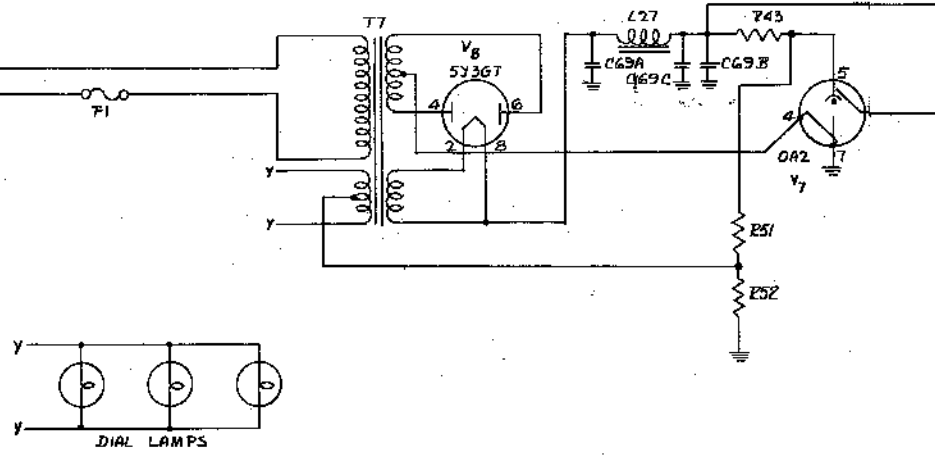

FREQ. XL = 2050 KC

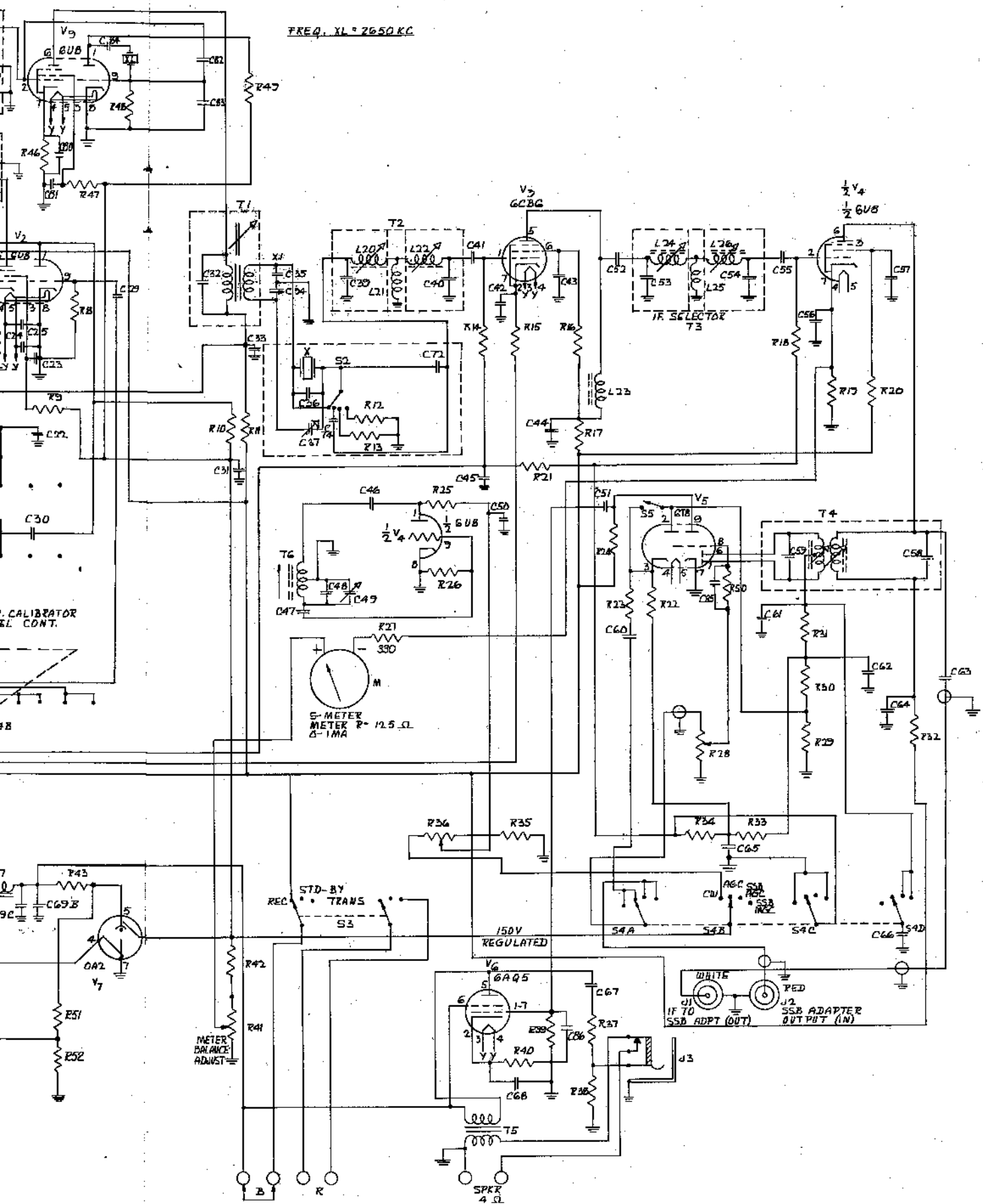

Model 4350A Tuning Knob Assembly

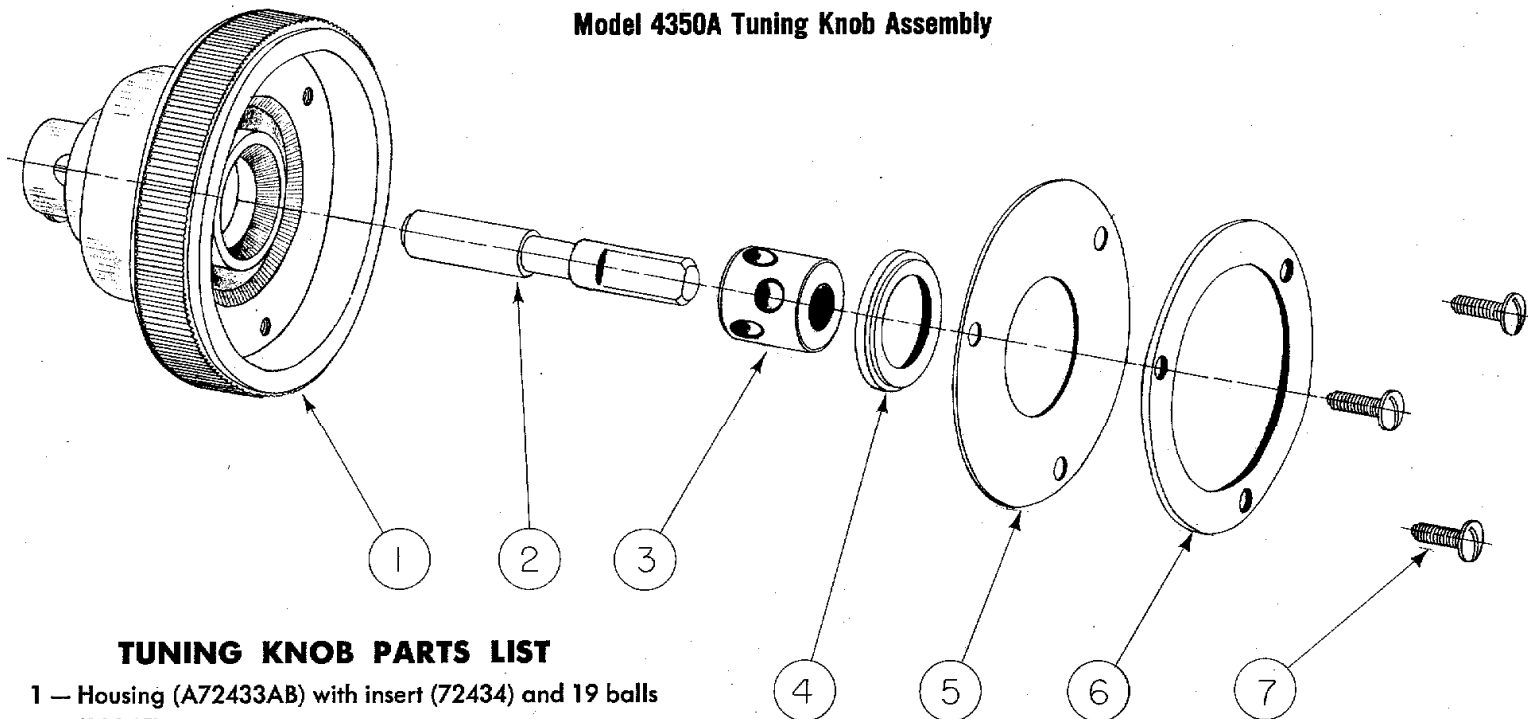

TUNING KNOB PARTS LIST

- 1 — Housing (A72433AB) with insert (72434) and 19 balls (20245)
- 2 — Shaft (72431)
- 3 — Ball cage (72430) with 6 balls (20246)
- 4 — Ring (72428)
- 5 — Plate (72429)
- 6 — Ring (72443)
- 7 — 3 screws (6031E5)

TUNING KNOB ASSEMBLY—All part numbers (2) through (7) can be disassembled and assembled from the housing (1) without dismounting (1) from panel and shaft. Slipping of knob or failure of pointer to follow knob may be the result of insufficient tension on the plate (5). Remedy by removing the front knob and tightening the three screws (7) $\frac{1}{8}$ turn each.

The RME 4301 sideband selector is an excellent companion for the RME 4350A, 4350 or 4300 receivers. The sideband selector provides easy selection of either sideband on suppressed carrier transmissions or AM phone signals. Adds up to 15 db of sensitivity to the receiver. Can be connected to any communications receiver using a 455KC IF. Or plug directly into the RME 4300, 4350 or 4350A in jacks provided.

Complete with built-in power supply, the Model 4301 has an extremely stable BFO balanced detector circuit, and accurate phase shift network. Included are adder and subtractor circuits to provide single sideband reception of either upper or lower sideband separately, double sideband exalted carrier reception or normal receiver operation. Selection is made with panel mounted rotary switch which provides instantaneous switching between upper and lower sideband and with 40 db attenuation of unwanted sidebands; this feature improves system selectivity and signal-to-noise ratio for standard AM and CW reception as well as SSB.

Controls: Sideband selector, vernier frequency control, on-off switch.

Tubes: 2-12AT7, 12AX7, 6AL5, plus selenium rectifier. Sturdy steel case and cast aluminum control panel in attractive instrument grey finish.

Size: 10" x 8 $\frac{1}{2}$ " x 10". Shipping weight, 16 lbs. Net each, \$75.00.

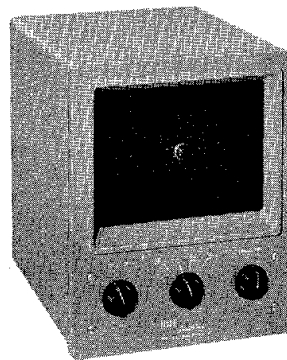

MODEL 4301

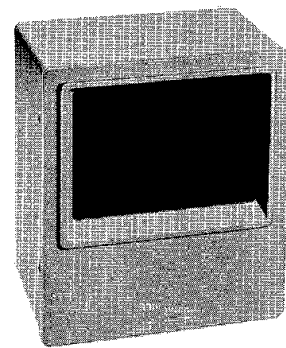

MODEL 4302

The Model 4302 speaker is housed in a sturdy steel case with cast aluminum front panel. The Model 4302 speaker is styled and finished to complement perfectly the Model 4300, 4350, 4350A and other quality receivers. For operation with any receiver having four-ohm speaker output terminals. The acoustic properties of the unit are tailored for optimum readability in communication operation. Finished in antiglare instrument grey. Size 10"x8 $\frac{1}{2}$ "x5 $\frac{1}{2}$ ". Shipping weight, 6 lbs. Net each, \$17.50.