

***REALISTIC***<sup>®</sup>

SOLID STATE  
FOUR BAND COMMUNICATIONS RECEIVER  
**SERVICE MANUAL**

MODEL DX-150A

C A T. No. 20-150

A PRODUCT OF RADIO SHACK<sup>®</sup>  
DIVISION OF TANDY CORPORATION

## CONTENTS

1. SPECIFICATION
2. GENERAL ALIGNMENT INSTRUCTIONS
3. INSTRUCTIONS FOR REPLACEMENT OF CHASSIS
4. PARTS LIST AND DESCRIPTION
5. FIG. 1 FRONT VIEW OF DX-150A CHASSIS
6. FIG. 2 TOP VIEW OF DX-150A CHASSIS PARTS LOCATION
7. FIG. 3 REAR VIEW OF DX-150A CHASSIS PARTS LOCATION
8. FIG. 4 SCHEMATIC DIAGRAM
9. FIG. 5 CHASSIS DIS-ASSEMBLY
10. FIG. 6 KNOB & SHAFT ASSEMBLY FOR BANDSPREAD
11. FIG. 7 KNOB & SHAFT ASSEMBLY FOR BFO PITCH
12. FIG. 8 PHONES JACK ASSEMBLY
13. FIG. 9 MAIN TUNING DIAL CORD ASSEMBLY
14. FIG. 10 BANDSPREAD DIAL CORD ASSEMBLY
15. FIG. 11 SUB PRINTED CIRCUIT BOARD TOP VIEW
16. FIG. 12 SUB PRINTED CIRCUIT BOARD REAR VIEW
17. FIG. 13 MAIN PRINTED CIRCUIT BOARD TOP VIEW
18. FIG. 14 MAIN PRINTED CIRCUIT BOARD REAR VIEW
19. FIG. 15 MAIN PRINTED WIRING DIAGRAM

## 1. SPECIFICATIONS

- 1.1 Circuit . . . . . 16 transistors, 14 diodes and 4 thermistors  
super-heterodyne system.  
Show Table 1 and Fig. 1 Schematic diagram.
- 1.2 Frequency . . . . . The RF tuning system covers the following four  
bands:
- 1 Band A            0.535 - 1.6 MHz
  - 2 Band B            1.55 - 4.5 MHz
  - 3 Band C            4.5 - 13 MHz
  - 4 Band D            13 - 30 MHz
- 1.3 Band spread. . . . . The band spread system covers the following  
frequencies:
- 1 80 Meter Band    3.5 - 4 MHz
  - 2 40 Meter Band    7 - 7.3 MHz
  - 3 20 Meter Band    14 - 14.35 MHz
  - 4 15 Meter Band    21 - 21.45 MHz
  - 5 10 Meter Band    28 - 29.7 MHz
- 1.4 Intermediate frequency . . . . . 455 KHz
- 1.5 Receiving sensitivity, signal to noise ratio and image ratio

Frequency	Sensitivity	S/N	Image
1400 KHz	Less than 50 $\mu$ V	More than 10 dB	More than 40 dB
4 KHz	10	10	30
12 KHz	10	10	16
28 M	10	10	4

Table 1. Transistor &amp; diode complement

Number	Type	Function
Q 1	2SK19	Cascade RF stage
Q 2	2SC373	AVC amplifier
Q 3	2SK19	Cascade RF stage
Q 4	2SK19	Mixer
Q 5	2SC372	1st IF amplifier
Q 6	2SC372	2nd IF amplifier
Q 7	2SK19	Local oscillator
Q 8	2SC372	B. F. O. stage
Q 9	2SC372	Buffer stage
Q 10	2SC373	Amplifier for CW/SSB
Q 11	2SC373	1st AF amplifier
Q 12	2SC373	2nd AF amplifier
Q 13	2SD72	AF power amplifier
Q 14	2SD72	AF power amplifier
Q 15	2SC373	AVC amplifier
Q 16	2SD146/2SC614 2SC971	DC regulator
D 1,2	1N34	Overload protector
D 3	1N73	1F noise limiter
D 4	1N34	AF detector
D 5	1N34	AF noise limiter
D 6,7	1N34	AVC detector
D 8	SZ-7	7V voltage regulator
D 9-12	1N34	Product detector
D 13,14	FR-1P	Rectifier
Th 1,2	D-1E	Temperature compensator

- 1.6 Loud speaker.....3" x 5" P.M. type
- 1.7 Power input & power consumption
  - 1 AC117V, 50/60 cps, 6VA
  - 2 DC12V, 5VA, Negative ground only
- 1.8 Controls on the feature
  - 1 Tuning dial
  - 2 Spread dial
  - 3 "S" meter
  - 4 ANL switch (on/off)
  - 5 Mode switch (AM/SSB, CW)
  - 6 AVC switch (fast/slow)
  - 7 Operation switch (rec./std. by)
  - 8 Phones jack
  - 9 Band spread control
  - 10 BFO pitch
  - 11 Power on/off & AF gain control
  - 12 Band selector
  - 13 Antenna trimmer
  - 14 RF gain control
  - 15 Main tuning control
- 1.9 Controls on the back
  - 1 Antenna terminal
  - 2 Fuse holder & fuse
  - 3 DC/AC change switch
  - 4 DC 12V power jack
  - 5 STD by jack

## 2. GENERAL ALIGNMENT INSTRUCTIONS

### 2.1 Test equipments

- 1 Standard signal generator or test oscillator
- 2 Vacuum tube voltmeter (P type)
- 3 Dummy load 8 ohms

### 2.2 General alignment conditions

- 1 Before servicing this receiver, disconnect from the power source and remove all load wires attached to terminal connections. Remove the six screws which fasten the chassis to the bonnet, speaker leads and remove the six screws which fasten the chassis to the bottom plate. Show Item 3.1 Chassis disassembly, Fig. 2-1 attached.

- 2 Knob function and it nominal position

Tuning Dia. . . . . 0, on Logical Scale

Spread Dial . . . . . V.C. Minimum

ANL Switch . . . . . OFF

Mode Switch . . . . . AM

AVC Switch . . . . . FAST

OPR Switch . . . . . REC.

BFO PITCH . . . . . -

AF GAIN . . . . . Adjust to Test Requirements

Band Selector . . . . . Adjust to Test Requirements

Antenna trimmer . . . . . Center

RF Gain . . . . . . . . . . Maximum

- 3 IF AMPLIFIER ALIGNMENT

Note: The non-metallic alignment tool are required for complete alignment. Unless otherwise specified, all front panel controls shall be positioned as Item 2.2-2 knob function & nominal position for complete alignment of the receiver.

The receiver should be warmed up for a period of at least 1/2 hour before proceeding with the complete alignment.

- A. S.G. Coupling .....  
Connect the S.G. output through a capacitor (50 pF) between VC 4 and chassis earth.
- B. S.G. Frequency ..... 455 KHz
- C. Adjust .....  
Adjust the cores of IF transformer MF, T1 and T2 for a maximum deflection on the "S" meter in a front dial.

-4 RF AMPLIFIER ALIGNMENT

Note: Alignment tool, nominal position of knobs and receiver condition should be required as Item 2.2-2 and 2.2-3.

- A. S.G. Coupling .....  
Connect the cable of S.G. output through a dummy antenna between A1 and GND on the antenna terminal.
- B. S.G. Frequency .....  
Three points characteristic alignment should be required on each A to D pass band. The plot frequency and modulation shall be positioned as follow:  
BAND A ..... 600KHz, 1000KHz & 1400KHz  
BAND B ..... 1.7MHz, 3MHz & 4MHz  
BAND C ..... 5MHz, 8MHz & 12MHz  
BAND D ..... 14MHz, 21MHz & 25MHz  
MODULATION 1KHz, 30%
- C. Connect V.T.V.M. ....  
Connect a a-c vacuum tube voltmeter to a phones jack with 8 ohms dummy load. Keep clear of low impedance speaker voice coil.
- D. Adjust .....  
Adjust the cores and trimmers of antenna, RF and oscillator coils for maximum deflection. Part number of the core and trimmer is as following table;

STAGE	ANT. STAGE		RF. STAGE		OSC. STAGE	
ADJ.	CORE	TRIM	CORE	TRIM	CORE	TRIM
BAND A	L1	VC1	L5	TC1	L9	TC5
BAND B	L2	VC1	L6	TC2	L10	TC6
BAND C	L3	VC1	L7	TC3	L11	TC7
BAND D	L4	VC1	L8	TC4	L12	TC8

Note: The oscillator adjustment are performed first.  
The RF is adjusted next to obtain maximum amplitude.  
The antenna cores adjusted last.

-5 B.F.O. ALIGNMENT

Note: The non-metallic alignment tool are required for complete alignment. The mode switch on the front panel should be positioned SSB/CW. A knob of the B.F.O. pitch on the front panel should be positioned one o'clock.

A. Signal coupling .....

Receive one of a broad cast frequency with exactitude by an antenna through the antenna terminal.

B. Connect V.T.V.M. ....

Connect a P type vacuum tube voltmeter probe between a side of T4 secondary coil and chassis earth.  
Set the vacuum tube voltmeter range on 1.5 volt.

C. Adjust .....

Adjust the core of the B.F.O. coil T3 for a zero beat note by loud speaker.  
Adjust the core of the B.F.O. coil T4 for a maximum deflection on vacuum tube voltmeter.



### 3. INSTRUCTION FOR REPLACEMENT OF CHASSIS AND DIAL CORD ASSEMBLY

#### 3.1 CHASSIS DIS-ASSEMBLY

Show Fig. 5 attached and Item 2.2-1

Note: Before the cabinet dis-assembly, pull out two of tips with speaker lead from loud speaker.

#### 3.2 DIAL CORD ASSEMBLY

- 1 Main tuning dial cord assembly show the Fig. 9 attached.
- 2 Bandsread dial cord assembly show the Fig.10 attached.

#### 3.3 KNOB SETTING POSITION FOR B.F.O. PITCH & ANTENNA TRIMMER

Set the knob slit on nine o'clock when a capacity of variable capacitor should be made maximum value.

#### 4. PARTS LIST AND DESCRIPTION

Symbol No. or Item No.	Description	Rating or Stock No.	Remarks
Q1.3.4.7	Transistor	2SK19	
Q5.6.8.9	"	2SC372	
Q2.10.11.12.15	"	2SC373	
Q13.14	"	2SD72	
Q16	"	2SD146 or equivalent	
Th1.2	Thermistor	M-10K	
Th3.4	"	D-1E	
D1.2.4.5.6.7.9.10.11.12	Diode	1N34A	
D3	"	1S73	
D13.14	"	FR1P	
D8	"	SZ-7	
D15	"	SZ-9	
T5	Power transformer	R6216	
T6	Input transformer	S9563C	
MF1	Mechanical filter	MFH-40K	
T1	IFT-1	YMC-15001A	
T2.4	IFT-2 & BFO buffer coil	YMC-15002A	
T3	BFO coil	HY-80112C	
L1	A band ANT. coil	12BNA-001	
L5	A band RF coil	7TNR-014	
L9	A band OSC coil	7TNO-015	
L2	B band ANT coil	7TNA-016	

Symbol No. or Item No.	Description	Rating or Stock No.	Remarks
L6	B band RF coil	7TNR-017	
L10	B band OSC coil	7TNO-018	
L3	C band ANT coil	7TNA-019	
L7	C band RF coil	7TNR-020	
L11	C band OSC coil	7TNO-021	
L4	D band ANT coil	7TNA-022	
L8	D band RF coil	7TNR-023	
L12	D band OSC coil	7TNO-024	
L13	250 $\mu$ H peaking coil	4LNC-025	
R3.56	Resistor 1/4W	22 ohms	
R58.60.66	" "	47 ohms	
R31	" "	100 ohms	
R6.10.29	" "	120 ohms	
R51	" "	150 ohms	
R57.64	" "	220 ohms	
R30	" "	270 ohms	
R7.65	" "	330 ohms	
R11.18.21.28. 35.55	" "	470 ohms	
R64	" "	910 ohms	
R12.14.15.19. 36.37.47	" "	1K ohms	
R9	" "	1.5K ohms	
R59.61	" "	1.8K ohms	

Symbol No. or Item No.	Description	Rating or Stock No.	Remarks
R22.44.65	Resistor 1/4W	3.3K ohms	
R16.26.33.38.45	" "	4.7K ohms	
R27.53	" "	6.8K ohms	
R2.4.5.13.23.25.52	" "	10K ohms	
R34.39	" "	15K ohms	
R17	" "	27K ohms	
R54	" "	39K ohms	
R32	" "	47K ohms	
R1	" "	100K ohms	
R24.40.41.42.43.48.49	" "	470K ohms	
R8	" "	1M ohms	
R20.16.50	" "	2.2M ohms	
R62.63	" 1/2W	4.7 ohms	
C7	Ceramic capacitor	5 pF 50WV	
C33	"	20 pF 50WV	
C53.57	"	50 pF 50WV	
C32	"	100 pF 50WV	
C1	"	150 pF 50WV	
C4.6.14	"	0.01 MF 50WV	
C22.23	"	0.02 MF 50WV	
C5.8.15.16.17.18.19.21.36.48.49.50.13	"	0.04 MF 50WV	

Symbol No. or Item No.	Description	Rating or Stock No.	Remarks
C61	Mylar capacitor	0.005 MF 50WV	
C51.52.54	"	0.01 MF 50WV	
C35.43	"	0.04 MF 50WV	
C25.26.28.55	"	0.1 MF 50WV	
C41	Styrol capacitor	10 pF 50WV	
C9	"	33 pF 50WV	
C2.42	"	68 pF 50WV	
C45	"	100 pF 50WV	
C37	"	150 pF 50WV	
C3	"	220 pF 50WV	
C11.38	"	470 pF 50WV	
C47	"	1000 pF 50WV	
C39	"	1500 pF 50WV	
C12.40	"	5000 pF 50WV	
C44	"	10000 pF 50WV	
C63	Oil capacitor	0.001 500WV	
C31.56.58	Chemical capacitor	1 MF 16WV	
C20	"	5MF 16WV	
C27	"	10 MF 16WV	
C24.46.59.62	"	50 MF 16WV	
C29.60	"	200 MF 16WV	
C34.65.66	"	500 MF 16WV	
C64	"	2000 MF 16WV	
C30	"	30 MF 16WV	

Symbol No. or Item No.	Description	Rating or Stock No.	Remarks
	Printed circuit board	GE-13B-1009	
	"	GE-13D-1010	
	Chassis	GE-11B-521A	
	Bottom plate	GE-11C-535A	
	Side angle-1	GE-11D-533-1A	
	" - 2	GE-11D-533-2A	
	Sub panel	GE-11D-534	
	VC mounting bracket	GE-11D-538A	
	Sub PC mounting bracket	GE-11D-593	
	Coil mounting chassis	GE-11D-577-A	
	Back panel	GE-11C-522A	
	Dial plate mounting bracket	GE-11C-537A	
	Cabinet	GE-11B-552	
	Dial pointer		
	Spread pointer		
	Variable capacitor	ECV-3HA43A21	
	"	2JJ02A18	
	"	S-30-60 pF	
	Pulley	90 $\phi$	
	"	70 $\phi$	
	"	40 $\phi$	
	Trimmer	B4-IM2	
	"	AT4-51/AT4-61	

Symbol No. or Item No.	Description	Rating or Stock No.	Remarks
	Rotary switch	Y6124	
SW11	Slide switch	9L	
SW7.9.12.8	"	14L	
	Volume	5KA C24S-SA21	
	RF control	2KB	
	Fuse holder		
	Fuse	0.5A	
	DC concent	4P NO.1476	
	2-pin plug & socket	NO.3822	
	Line cord strain relief		
	Foot	No.4850 #20	
	Rubber grommet	No.4108	
	Pilot lamp	8V	
	"	Lead type	
	Pilot lamp socket		
	Ant terminal	3P	
	Phones jack		
	S meter		
	Line cord	UL Type 6 feet	
	Main dial shaft	GE-12D-726	
	Spread dial shaft	GE-12D-728	
	"	GE-12D-727	
	Spread dial plate		

Symbol No. or Item No.	Description	Rating or Stock No.	Remarks
	Main dial plate		
	Front panel	GE-11B-536	
	Heat sink L type		
	Heat sink saddle		
	Knob	Large	
	"	Small	
	Back board	GE-11D-587A	
	SPK board	GE-11D-595	
	Bar Ant. holder		
	Instruction manual		



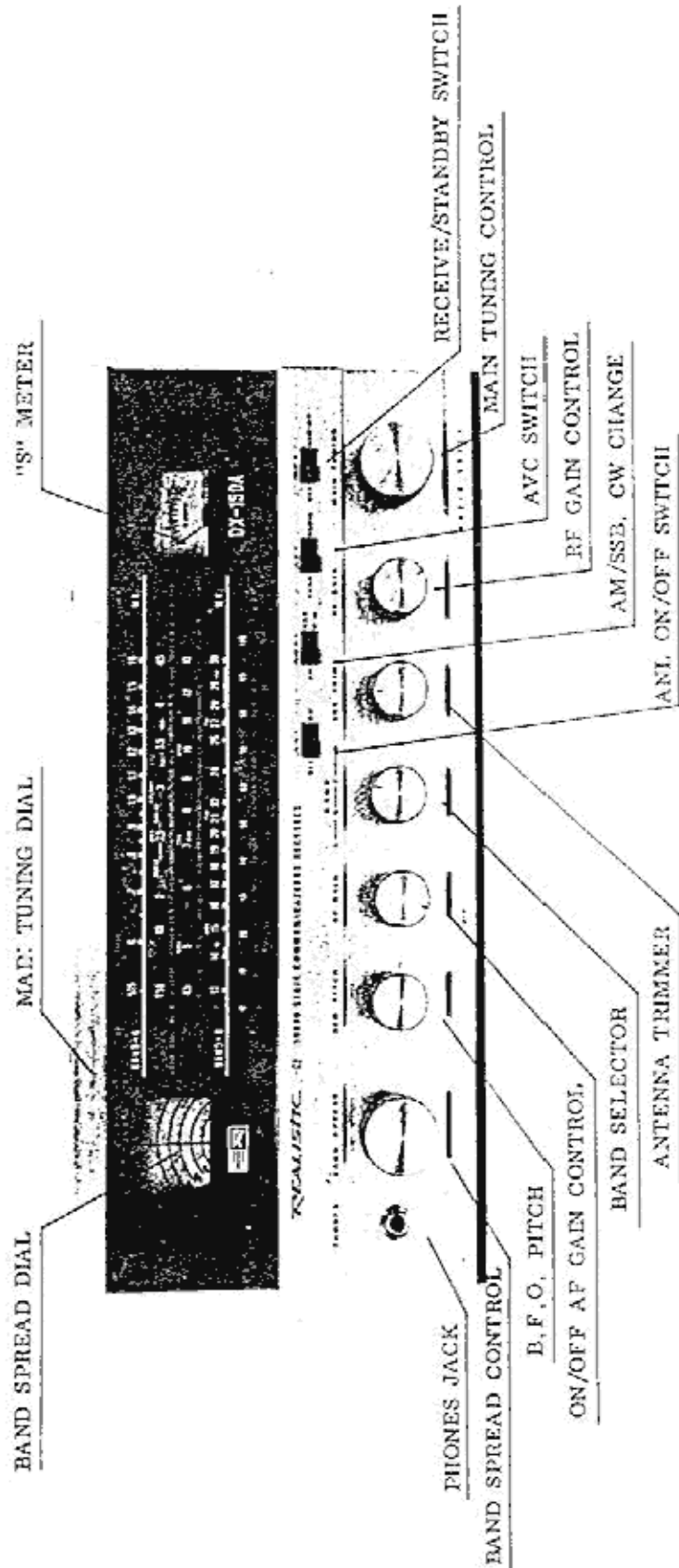

FIG 1 FRONT VIEW OF DX-150A CHASSIS

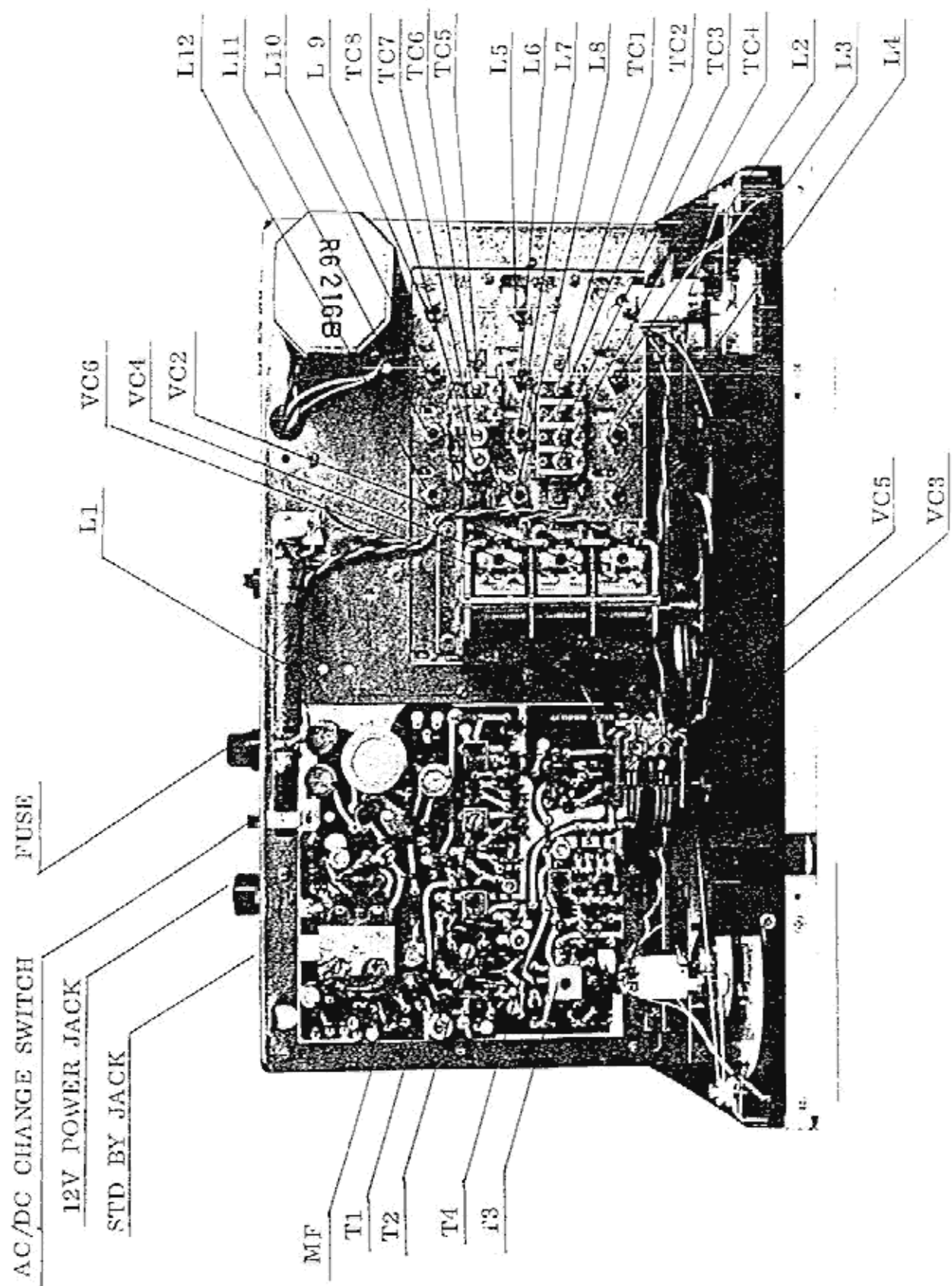

FIG. 2 TOP VIEW OF DX-150A CHASSIS PARTS LOCATION

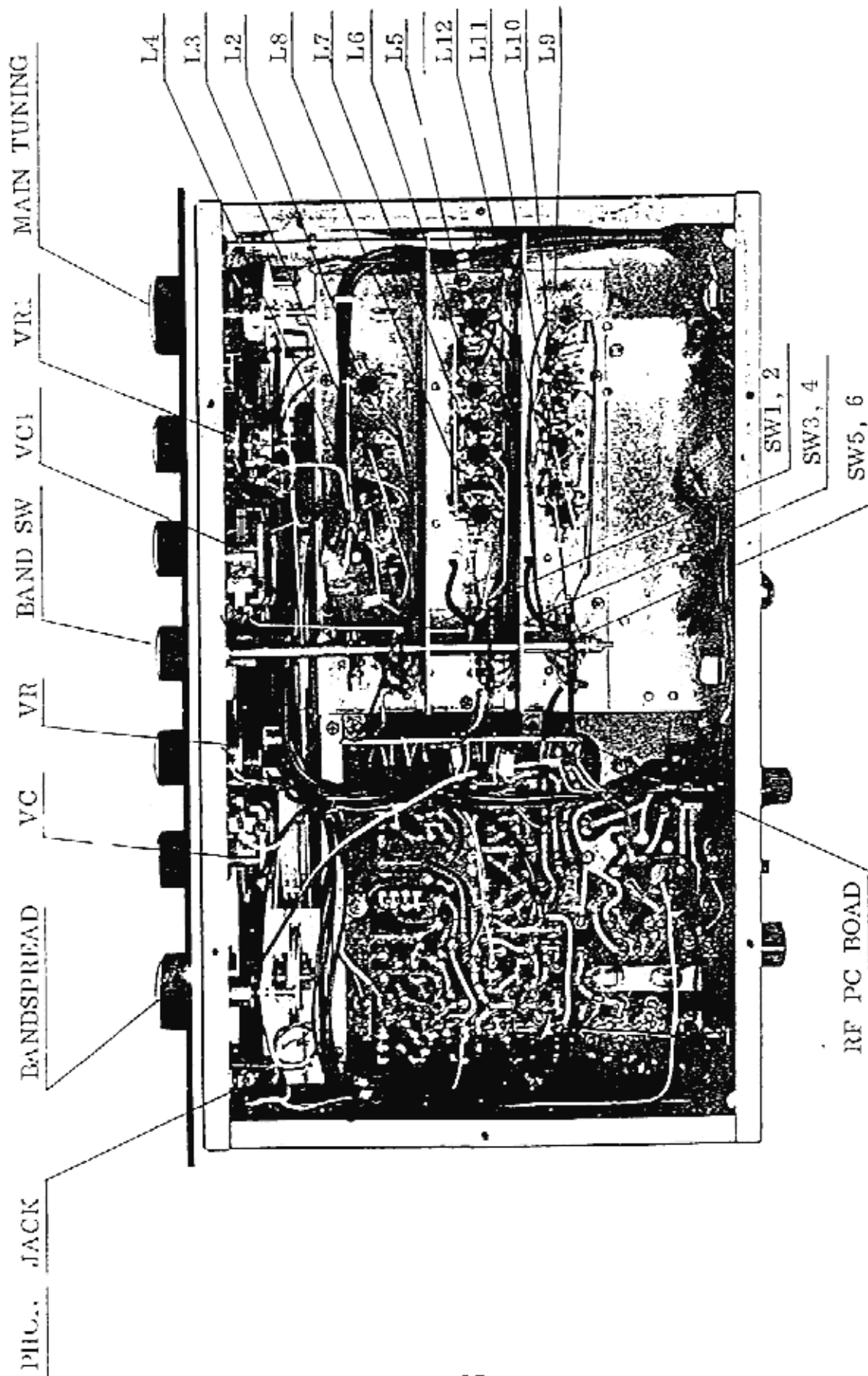
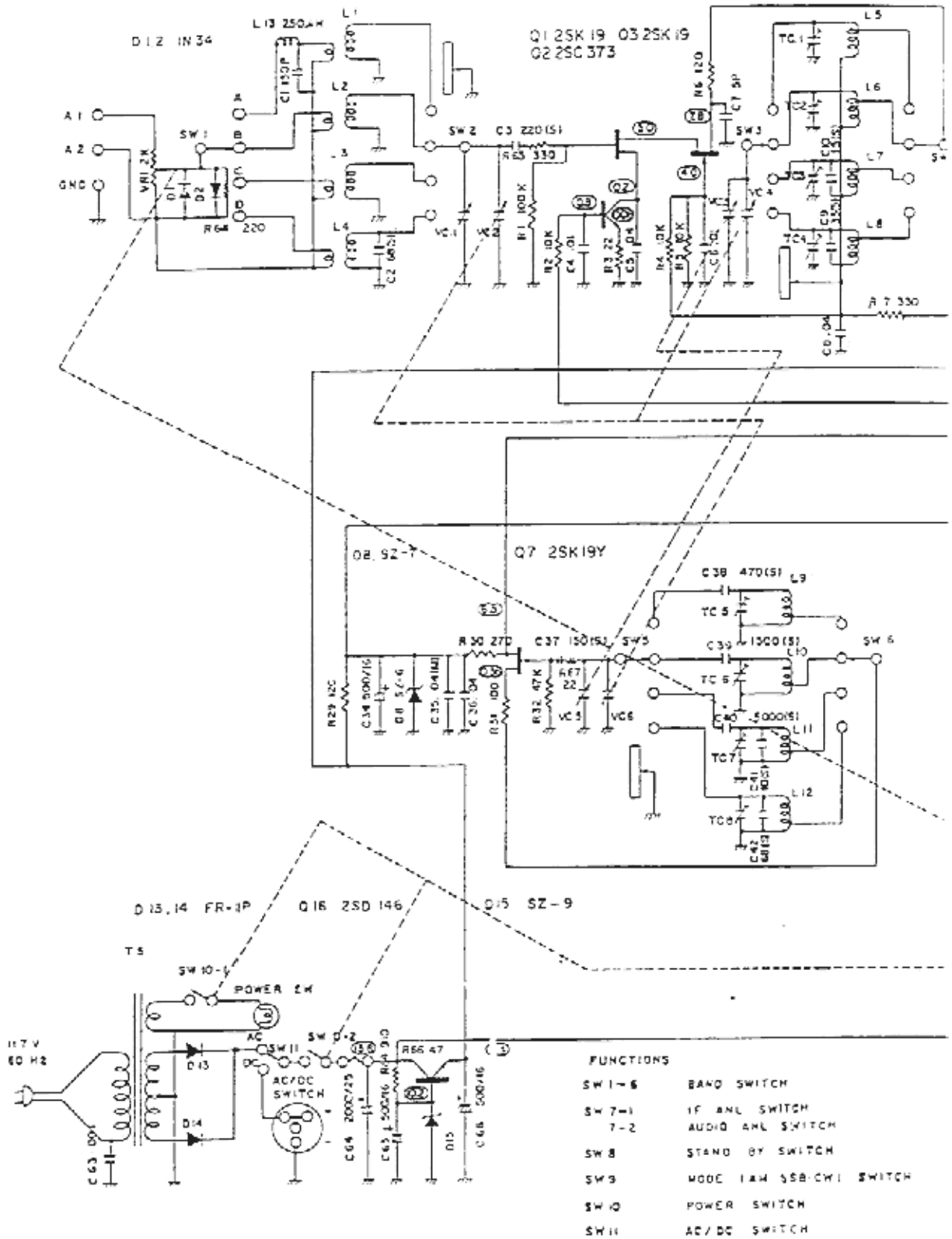

FIG. 3 REAR VIEW OF DX-150A CHASSIS PARTS LOCATION



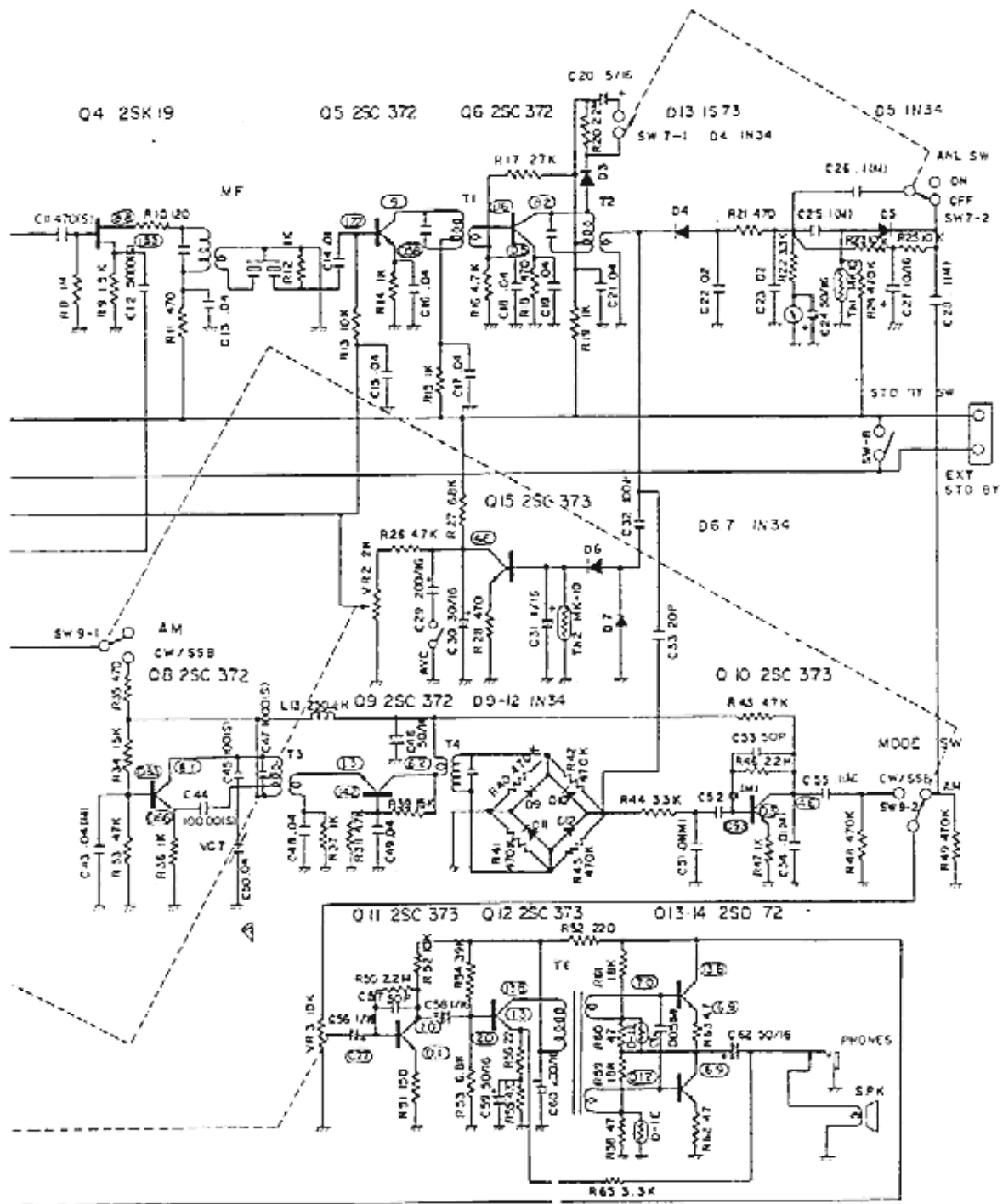
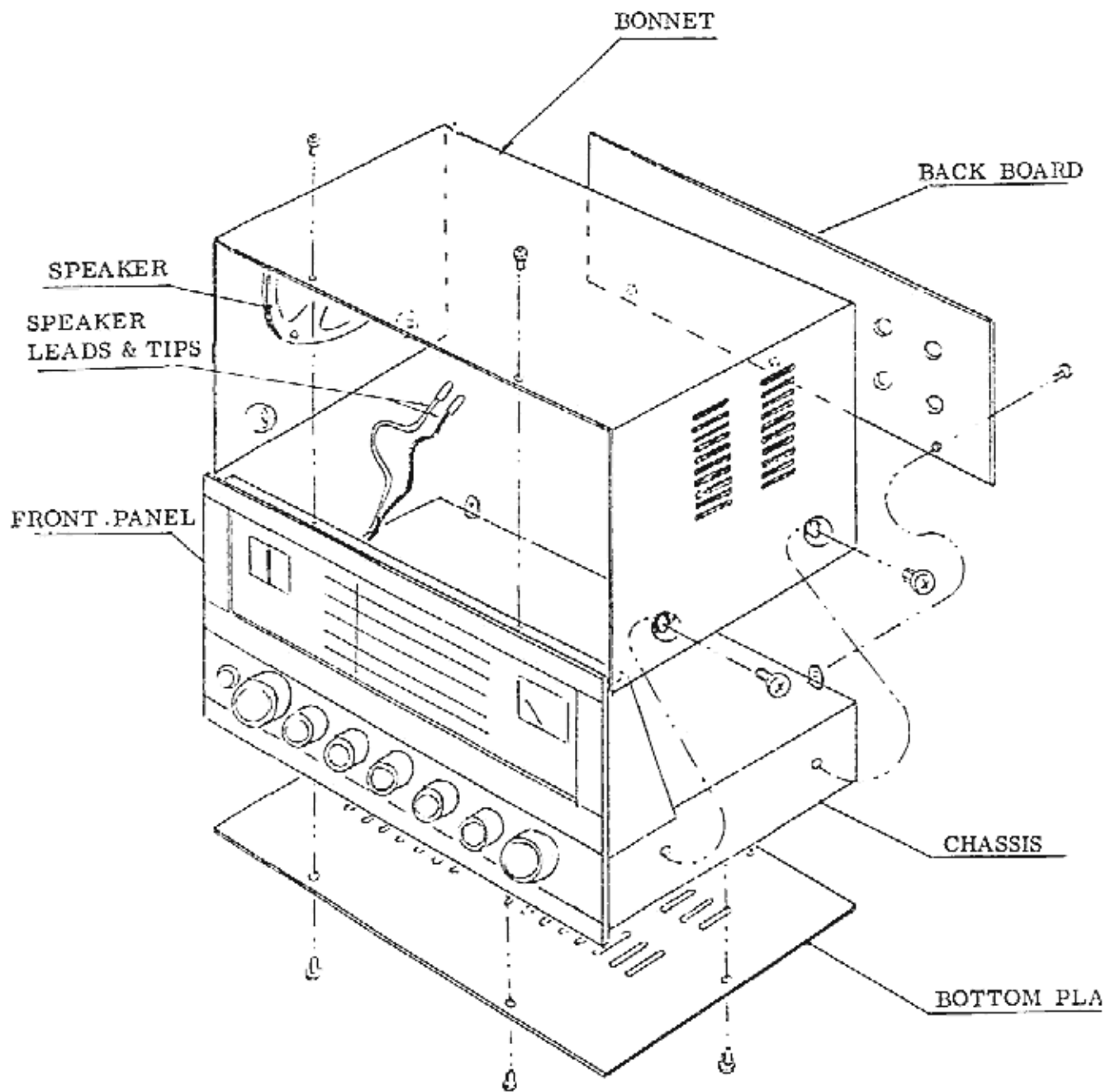

FIG. 4 SCHEMATIC DIAGRAM



Note: Before the chassis dis-assembly, take pull out two of TIPS with speaker lead wires.

FIG. 5 CHASSIS DIS-ASSEMBLY

KNOB & SHAFT ASSEMBLY

for

Bandspread control shaft  
Band selector shaft  
main tuning control shaft

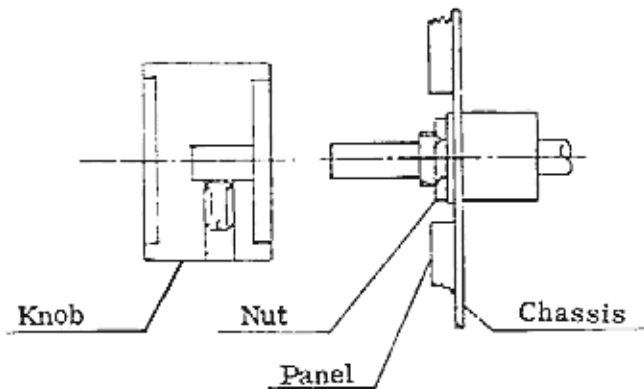

FIG. 6 KNOB & SHAFT ASSEMBLY FOR BANDSPREAD

KNOB & SHAFT ASSEMBLY

for

BFO pitch shaft  
ON/OFF, AF gain control shaft  
Antenna trimmer shaft  
RF gain control shaft

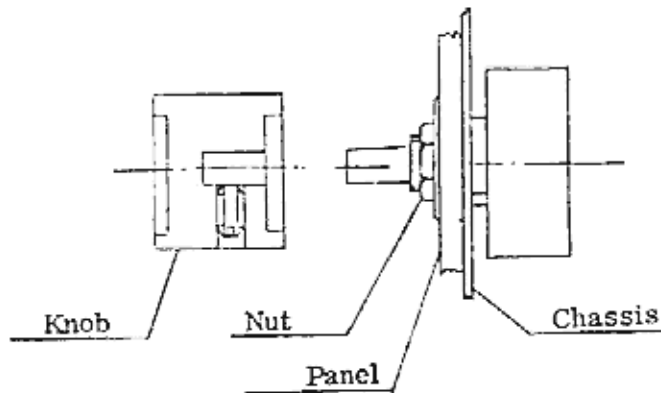

FIG. 7 KNOB & SHAFT ASSEMBLY FOR BFO PITCH

PHONE JACK ASSEMBLY

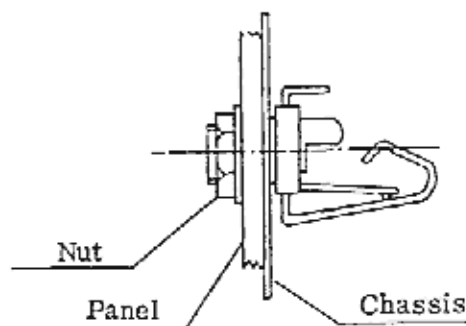

FIG. 8 PHONES JACK ASSEMBLY

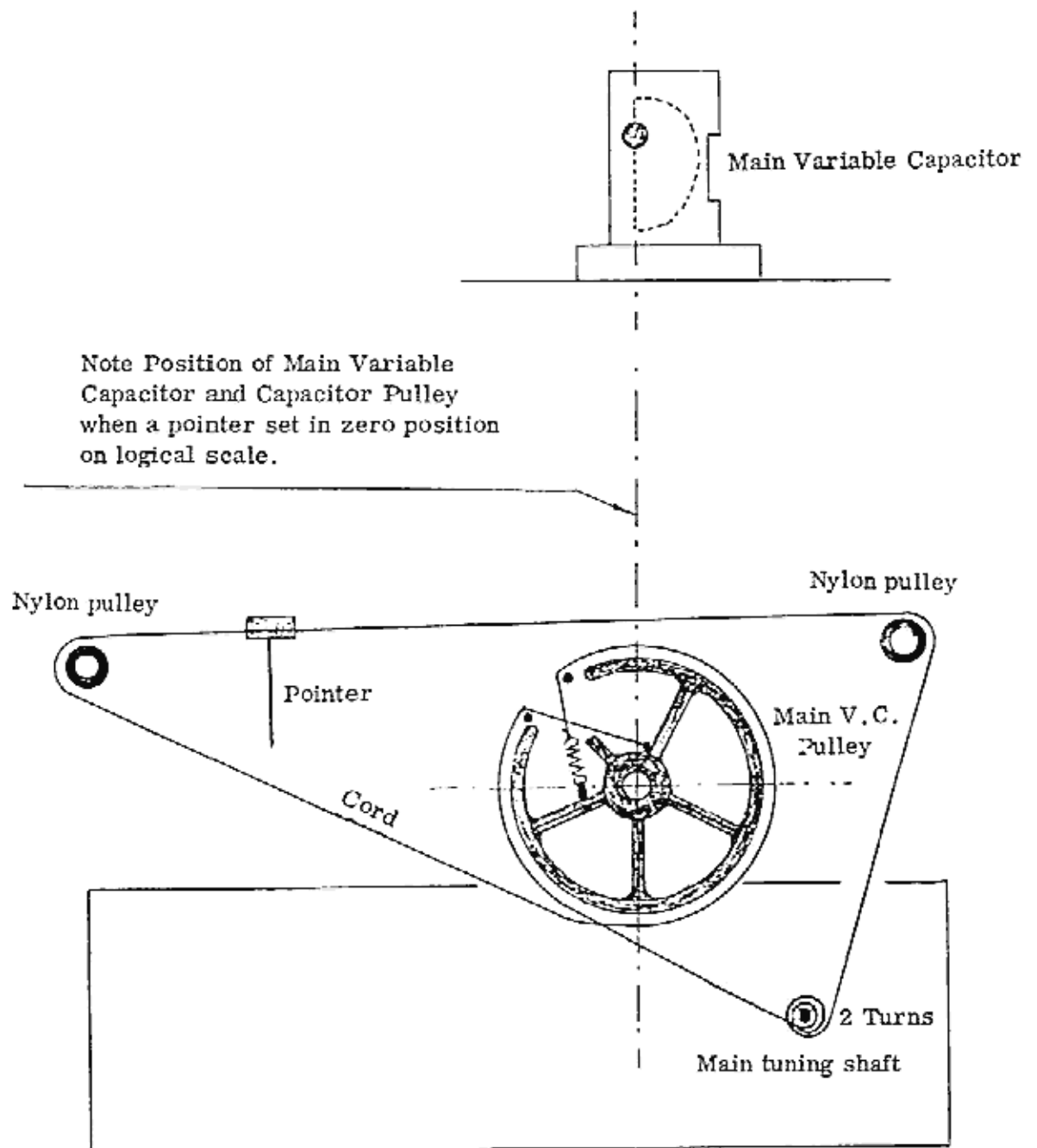
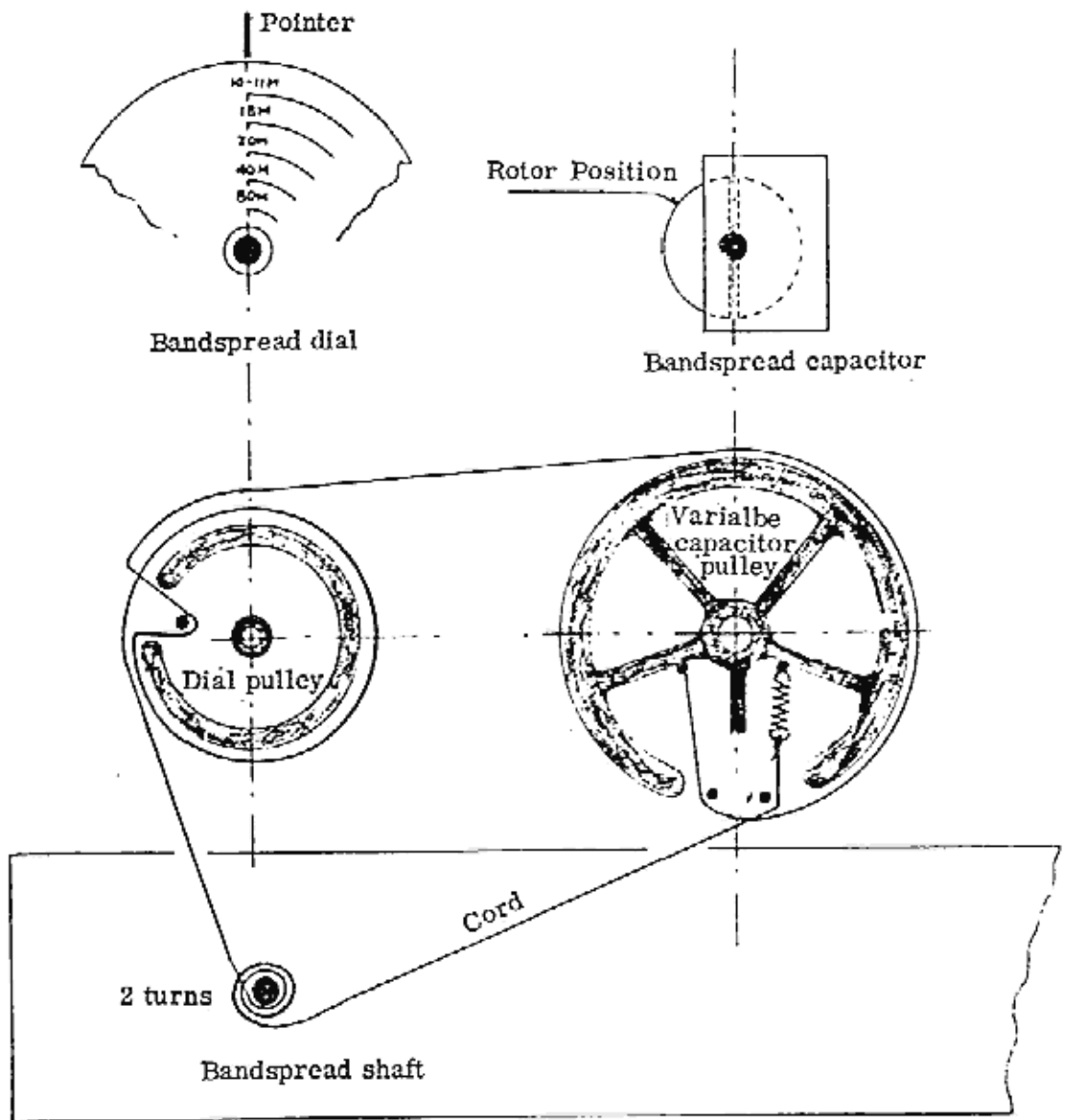

FIG. 9 MAIN TUNING DIAL CORD ASSEMBLY





Four of Note position for Bandspread Dial, Dial pulley, Variable capacitor and Capacitor pulley.

FIG. 10 BANDSPREAD DIAL CORD ASSEMBLY

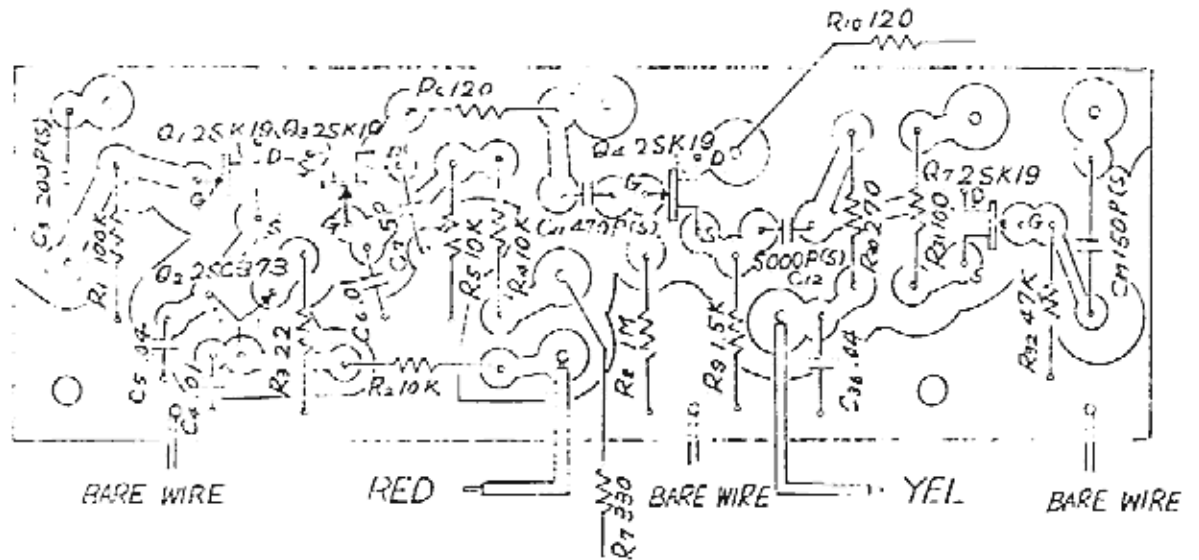

FIG.11 SUB PRINTED CIRCUIT BOARD TOP VIEW

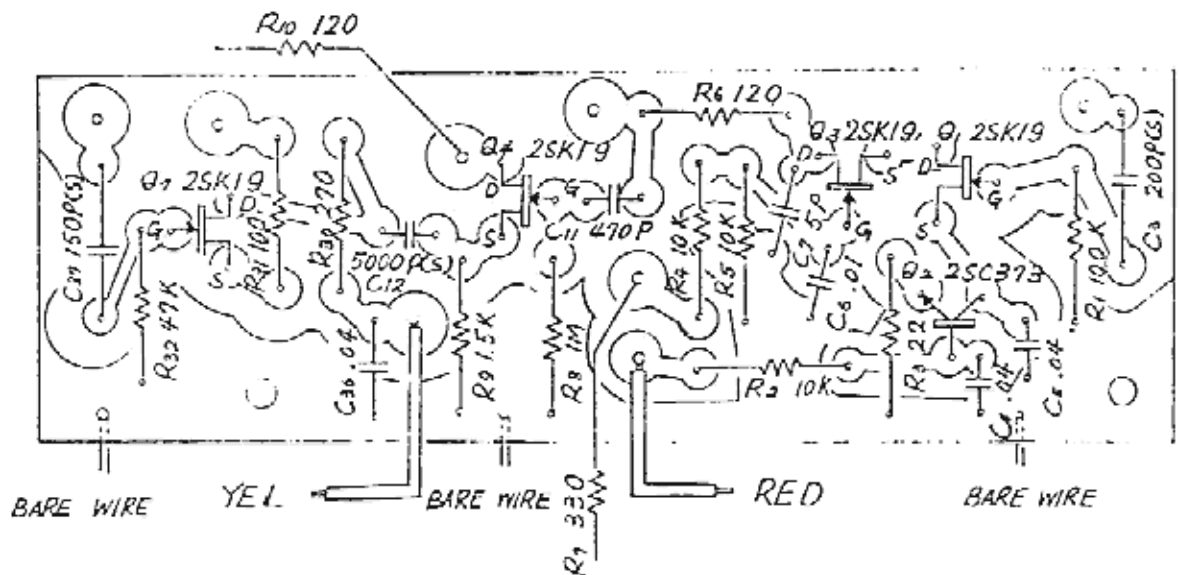

FIG.12 SUB PRINTED CIRCUIT BOARD REAR VIEW

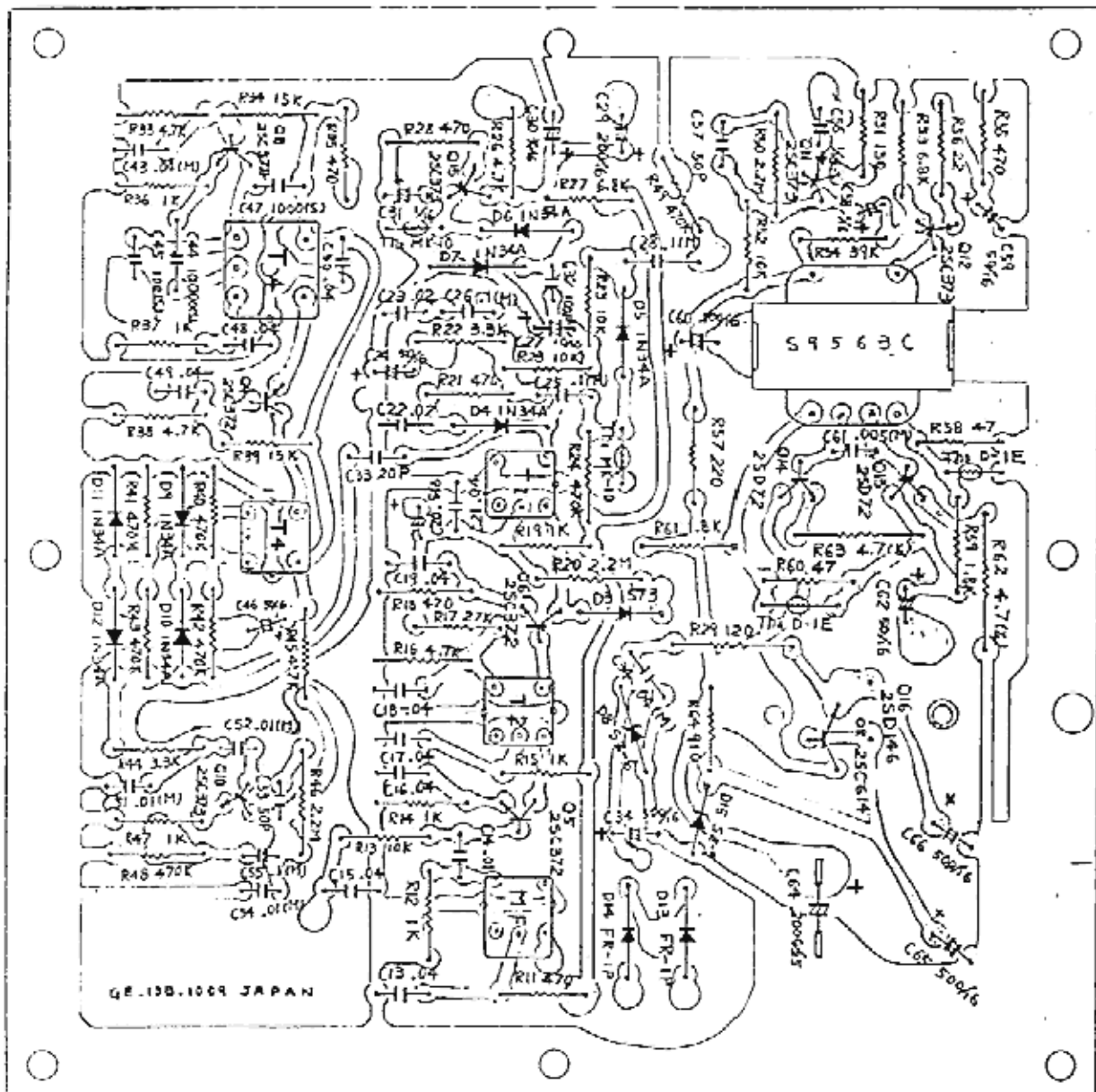

FIG.13 MAIN PRINTED CIRCUIT BOARD TOP VIEW

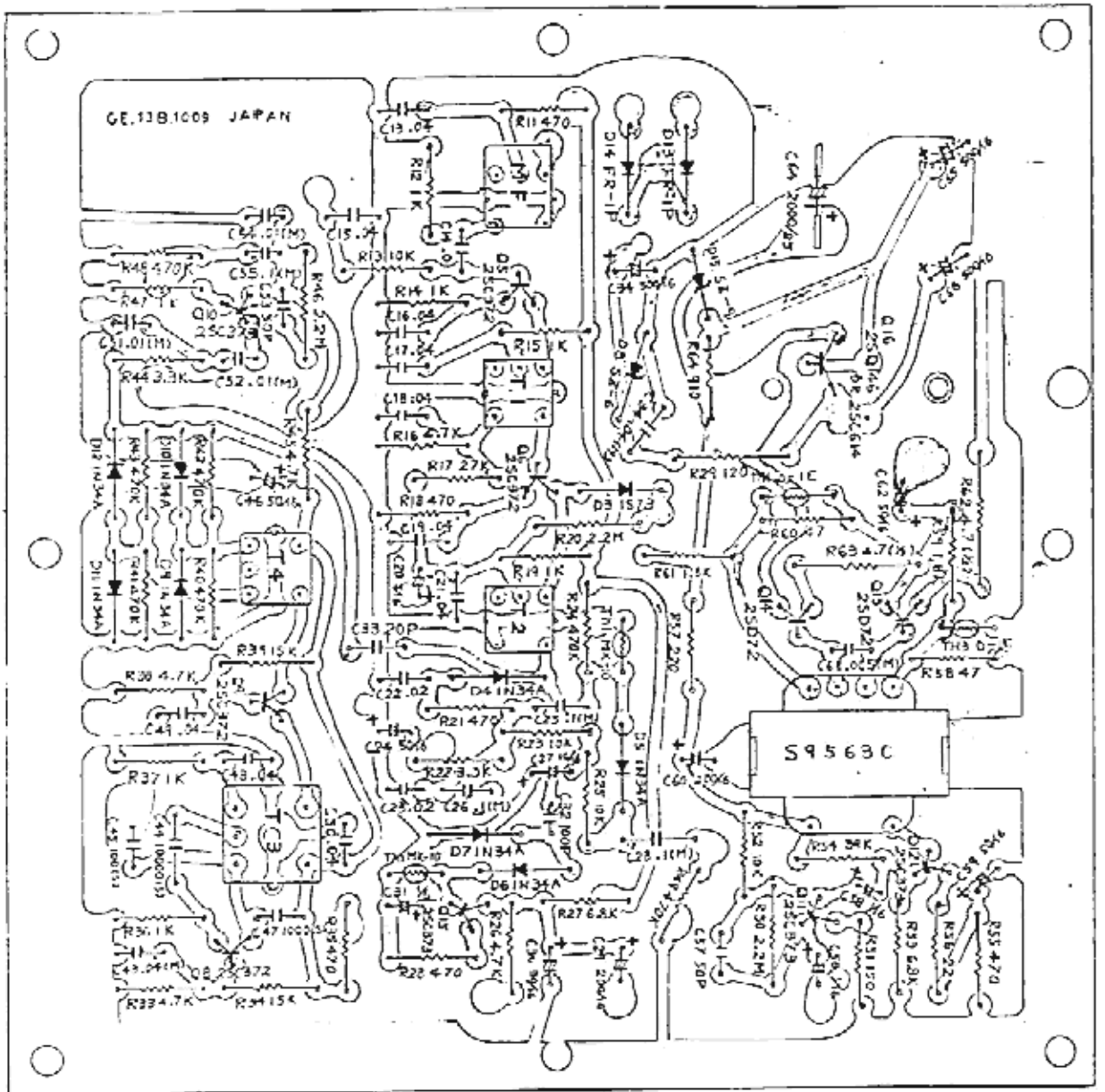

FIG. 14 MAIN PRINTED CIRCUIT BOARD REAR VIEW

