

SONY®



3002412

SONY BDA

CRF5090

CRF-5090

OPERATING INSTRUCTIONS

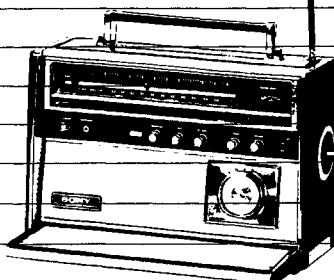

World Zone

MC-Service

The SONY CRF-5090, "World Zone", presents you with the listening enjoyment of a total of 9 bands. This receiver tunes the most popular 5 international shortwave bands, as well as MW, LW, FM and AIR bands.

So you can receive Marine, Weather, Ship-to-Ship or Ship-to-Shore transmissions, radio beacons, time signals, FAA Weather Navigation, radio hams, SSB/CW signals, and aviation communications, as well as standard AM and FM broadcasts.

A new solid-state chassis including a BFO control, an RF gain control, a squelch control, a tuning meter and the SONY LED tuning indicator ensure fine reception.

Enjoy your "World Zone" to the utmost.

TABLE OF CONTENTS

Power Source	4
Location of Parts and Controls	5
Function of Parts and Controls	7
Outdoor Antenna	11
Operating Steps	12
The Time Zone Chart	13
Features of Each Band	14
Direction Finding	16
Specifications	17

POWER SOURCE

With Standard Batteries

Pull the knobs on the rear cover and remove the cover. The lower two narrow compartments are for installing batteries. Insert four batteries (size D) into each compartment with the correct polarity \oplus \ominus . It is recommended to install the marked battery (O) last, as shown below. When the sound becomes weak or distorted, replace all the batteries with the new ones. The marked one can be taken off first.

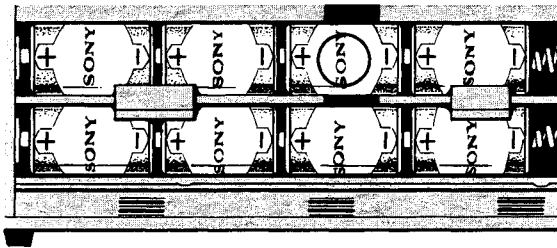

On House Current

The AC power cord is stored in the upper compartment. Insert the four-hole plug of the AC power cord into the power socket [AC/DC IN] located at the lower right of the rear panel, and connect the other end to an AC house current outlet.

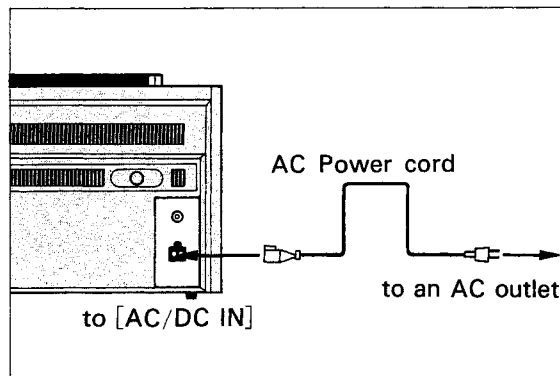

On Auto/Boat Battery

Use SONY Car Battery Cord DCC-2AW, an optional accessory. The round plug of the car battery cord is to be inserted into the cigarette lighter socket of the car or boat using a 12-Volt battery.

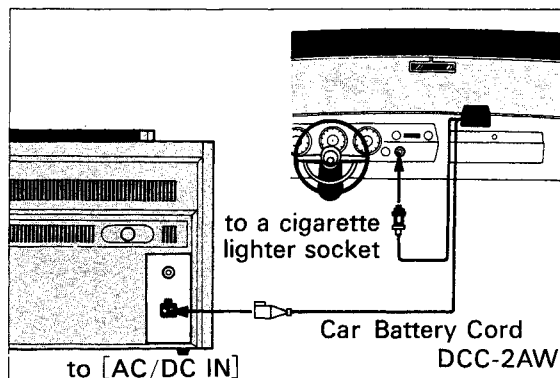

LOCATION OF PARTS AND CONTROLS

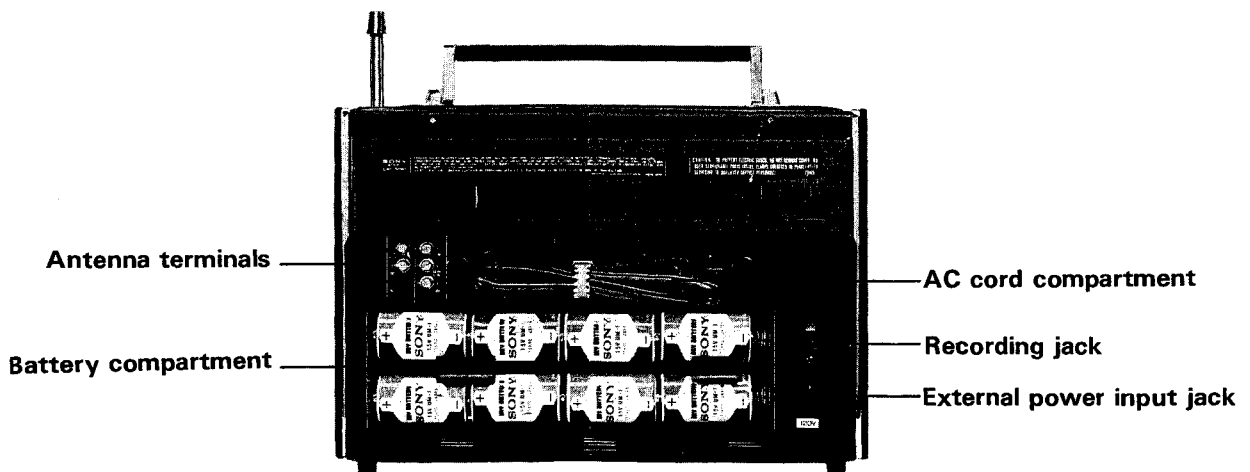
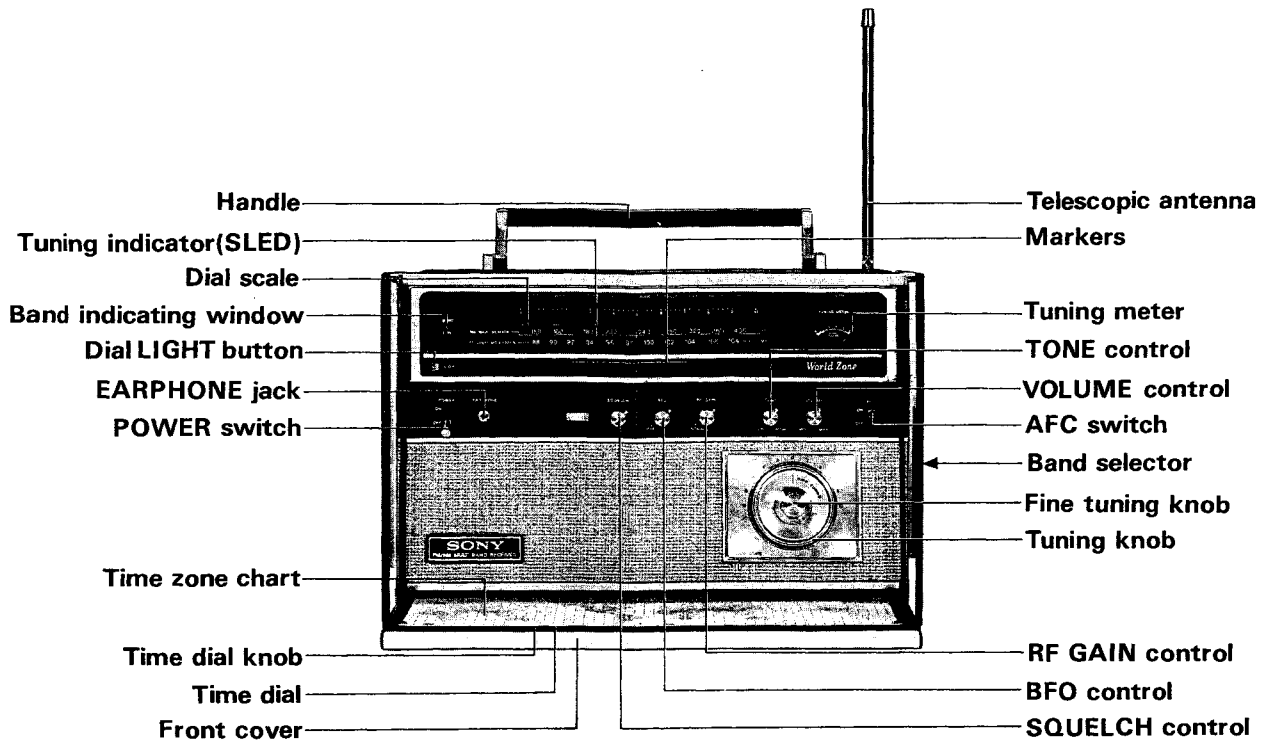



FUNCTION OF PARTS AND CONTROLS

Telescopic Antenna

This antenna is for use on SW1-5, FM and AIR band reception. For SW1-5 band reception, pull out the antenna to its full length and stand it vertically.

For FM or AIR band reception, first pull out the antenna rod to its full length, then slant it and vary the length, direction and angle for best reception.

In AIR band reception, it is recommended to shorten the Telescopic antenna. Since the wave length of AIR band is shorter than FM band, better result may be obtained.

In areas where strong FM broadcast stations are located, AIR band reception may not necessarily be improved by using an external FM antenna.

In these circumstances, use an antenna designed for AIR band reception only.

For MW and LW (beacon) band reception, the built-in ferrite bar antenna is effective. Since this antenna is directional, rotate the set horizontally for optimum reception.

POWER Switch

Flip the switch upward to turn the set ON. If you operate the set from the AC power line, the Dial scale and the Tuning meter lights. To turn off the set, flip the switch down to OFF. Make sure that the switch is set to OFF, when you close the front cover.

BAND SELECTOR

Rotate the knob until the desired band appears in the Band indicating window.

Tuning Knob

This knob is for tuning in the desired station.

Dial Scale

Tuning Indicator

The newly-developed SONY Light Emitting Diode brightens at correct tuning.

Band Indicating Window

TUNING METER

When tuning in, the pointer swings to the right. During SSB/CW (single sideband/continuous wave) reception, this meter is not effective.

Dial LIGHT Button

When you operate the set from batteries, press this switch to illuminate the Dial scale for easy reading.

Markers

If you position a Marker at a frequency that you often tune in, you can locate the station more easily the next time. At first, tune in the station precisely with the Tuning knob and the Fine tuning knob (for AM), so that the Tuning indicator brightens and the Tuning meter swings to the right. Then set a Marker at the Tuning indicator hairline. Do the same with the remaining two Markers for other often-used frequencies. These Markers are especially convenient for the AIR band reception where signals are not continuously broadcast. The markers enable you to select the proper frequency even when no signal is being broadcast. Then the selected station will be heard as soon as a transmission does occur.

FINE TUNING Knob

This knob is useful for tuning in a short wave station easily. At first, set the [I] mark on the Fine tuning knob to [0]. Then tune in the station as best as you can with the Tuning knob. Turn the Fine tuning knob until the best reception is obtained. This knob is also helpful on SSB/CW reception.

AFC Switch

Automatic frequency control is effective for stable FM reception. Generally, keep this switch ON. If the desired FM station is weak or adjacent in frequency (within 1 MHz) to a strong signal station, depress the AFC switch to cut off the automatic frequency control. This lets you tune in the desired station without it being pulled off frequency.

VOLUME Control

Clockwise rotation of this control increases the sound volume.

TONE Control

Turn this control to HIGH to accentuate treble sound. Turn this control to LOW to accentuate bass sound.

RF GAIN Control

Usually, set this control to off ([NORMAL] position). However, if you are located in a region where the signals are very strong, this control may improve the reception except for FM and AIR band reception.

When SSB/CW signal reception, this control is effective. Turn this control clockwise with a click and adjust the control until the clearest signal is obtained.

BFO Control

Used for SSB/CW reception. Turn this control clockwise with a click, and adjust the control precisely until the content of transmission is heard clearly.

Be sure to set this control to OFF for reception of any other type of broadcast.

SQUELCH Control

In AIR band reception, this control operates to eliminate the noise and static heard between transmissions to an acceptable level. When receiving weak signals, readjust the antenna, or turn the control fully counterclockwise. In this case, be careful not to increase the sound volume because strong noise will occur when a station is not tuned in.

EARPHONE Jack

Plug the supplied earphone into the jack. The built-in speaker will automatically be disconnected.

Recording Jack

Connect the recording jack to the microphone jack of a tape recorder through the proper connecting cord for recording radio programs.

The position of the Volume and Tone controls does not affect the recording level.

For further details, refer to the instruction manual of your tape recorder.

Front Cover

Open the front cover of the receiver by placing your fingers in the groove on the cabinet top and pulling toward you.

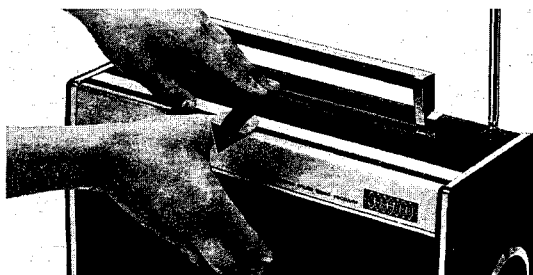

Insert the front cover into the cabinet. This will stop halfway so as to leave the Time zone chart exposed.

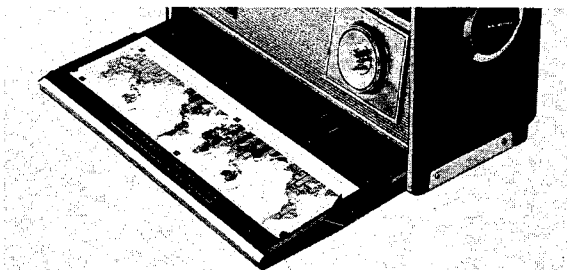

To close the front cover, first draw it out, flip it up, and then press it to the cabinet until you hear a click.

To remove the front cover, pull the front cover horizontally toward you while pulling the tiny spring.

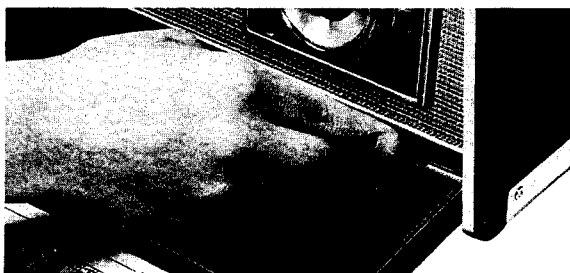

To reinstall the cover, insert it into the cabinet while pushing the spring. The cover will be locked in the cabinet.

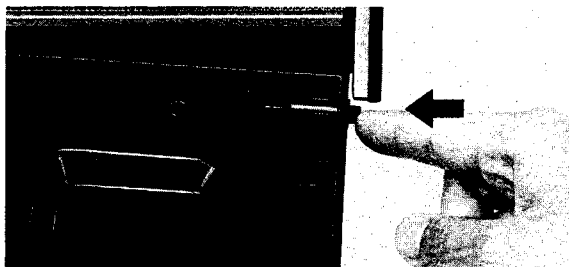

OUTDOOR ANTENNA

FM and AIR Bands

Use a popular outdoor antenna to increase the sensitivity. To do this, unfasten and remove the hook of the Telescopic antenna lead-in wire. Loosen the FM/AIR antenna terminal screws and connect the feeder wire of the outdoor antenna to the terminals behind the washer.

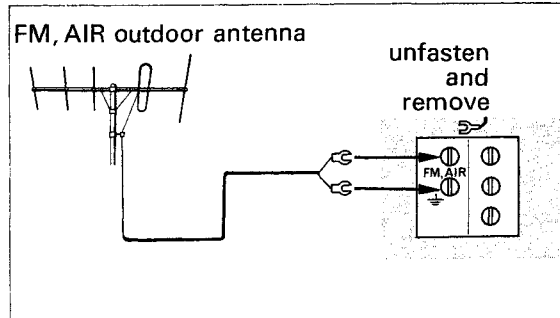

SW 1-5 Bands

When receiving shortwave, connect the antenna wire of SW outdoor antenna to SW antenna terminal for greater sensitivity and lower noise. If noise still persists, attach a groundwire to the Ground terminal [\perp] and connect the other end of the wire to a suitable electrical ground such as a cold water pipe.

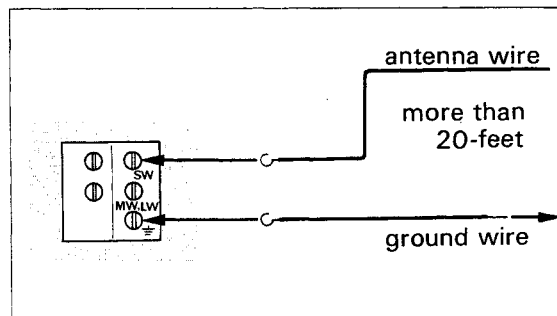

MW and LW Bands

Connect an antenna wire more than 20-feet long to the MW/LW antenna terminal, and extend it outdoors as high as possible. Also, the use of a ground wire may provide better reception.

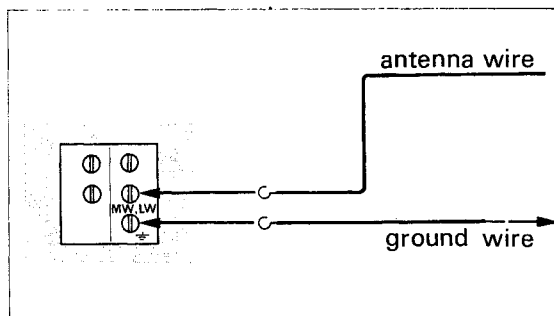

OPERATING STEPS

FM Reception

1. Pull out the Telescopic antenna to its full length. Adjust the direction and angle.
2. Turn on the POWER switch.
3. Select the FM band with the Band selector.
4. Set the AFC switch to ON.
5. Tune in the desired station by turning the Tuning knob.
6. Adjust the sound volume and tone quality by turning the Volume and Tone controls.

MW/LW Reception

1. Turn on the POWER switch.
2. Set the RF GAIN control to NORMAL and the BFO control to OFF.
3. Select the band with the Band selector.
4. Tune in the desired station by turning the Tuning knob.
5. Adjust the sound volume and tone quality.

NOTE: The Telescopic antenna has no effect on MW/LW reception. Instead, the built-in directional ferrite bar antenna is used.

SW Reception (shortwave 1-5)

1. Pull out the Telescopic antenna to its full length and stand it vertically.
2. Turn on the POWER switch.
3. Set the RF GAIN control to NORMAL and the BFO control to OFF.
4. Select the band (SW 1-5) you want with the BAND SELECTOR.
5. Tune in the desired station.
At first, set the [] mark on the FINE TUNING knob to [0]. Then turn the Tuning knob and select the station precisely. Turn the FINE TUNING knob until the best reception is obtained.
6. Adjust the volume and tone.

For SSB/CW reception, add the following steps.

7. Turn the BFO control clockwise with a click until the clearest signal is received.
8. If you are located in the areas where the signal is strong and the signal is still distorted, turn the RF GAIN control on by turning it clockwise with a click.

If you try to receive SSB or CW immediately after you have turned on the power, the reception may be difficult due to the frequency drift led by the temperature characteristic of transistors. You can enjoy the stable SSB or CW reception about 10 minutes after you have turned on the power.

AIR Reception

1. Pull out the Telescopic antenna. Recommended to shorten the antenna length less than FM reception. Adjust its direction and angle.
2. Turn on the POWER switch.
3. Select the AIR band with the BAND SELECTOR.
4. Tune in the desired aviation communication transmission with the Tuning knob.
5. Turn the SQUELCH control clockwise until background noise is reduced to an acceptable level for listening.
6. Adjust the volume and tone.

THE TIME ZONE CHART

The Time zone chart composed of the Time dial and the World map is located on the back of the front cover.

This helps you to find out the time of day anywhere of the world or determine the difference in time between GMT and local time.

Use it as follows.

Slide the Time dial right or left to set the number on the Time dial corresponding to the current local time to the time zone in which you are located. The Time dial will now indicate the correct time in each of the other time zones.

○The Time dial of the set uses the 24 hour method of designating time. For example 5 p.m. is equal to 17 hours. If the time is past 12 hours, you can convert to conventional p.m. time by subtracting 12 hours from the time.

To determine the correct time anywhere on earth, set the time number on the Time dial to the desired location and find out the time at the other areas.

For example, when it is 10 a.m. in New York, what time is it in London? The Time dial indicates the correct time in London is 15 hours. Convert 15 hours to p.m. time. It will be 3 p.m.

Keep in mind when you cross the International Date Line, the date changes. In case going west from that line, it becomes the following date. On the other hand, going east, it becomes the previous date.

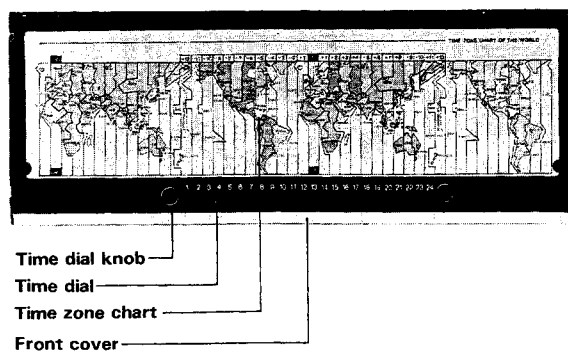

FEATURES OF EACH BAND

AIR (Aircraft communication band)

This band provides reception of aviation communications 108-136 MHz range between aircraft and airport towers such as a pilot's request for specific instructions, report of his position, filing of his flight plan, etc.

You may also receive plane-to-plane communications. For details on aircraft frequencies, refer to the Airman's Information Manual published by the FAA or the following chart.

Frequency Chart of Aviation Communication (voice)

118.0-121.4 MHz	air traffic control communications for civil aircraft
121.5MHz	emergency frequency This is the universal VHF frequency for emergency and distress communication and its use should be limited to such calls, generally available at all FAA and military stations, through either the tower or the FSS (Flight Service Station).
121.7-121.9 MHz	airport ground control frequency, for communication between tower and taxiing aircraft or vehicles
121.95MHz	flight test
122.0MHz	FSS's weather, selected locations, private aircraft and air carriers.
122.1MHz	standard FSS guarding frequency for civil aircraft.
122.2, 122.3 MHz	FSS simplex frequency for civil aircraft at selected locations.
122.4, 122.5, 122.7MHz	standard FAA (Federal Aviation Agency) tower guarding frequency for civil aircraft
122.6MHz	FSS's private aircraft
122.8, 123.0, 122.95MHz	aeronautical advisory stations (UNICOM) for a communication with civil aircraft at airports having no tower or FSS
122.9MHz	aeronautical multicom stations for communication pertaining to agriculture, ranching, forest fire fighting, parachute jumping, etc
123.0MHz	aeronautical advisory stations (UNICOM) at airports with ATC tower or FSS.
123.05MHz	UNICOM for heliports

123.1, 123.55 MHz	flying school and flight test stations
123.6MHz	FSS airport advisory service
123.6-128.8 MHz	air traffic control frequencies except 126.2, assigned primarily as military tower frequency
128.85-132.0 MHz	aeronautical en route operations (airing)
132.05-135.95 MHz	air traffic control communications except 133.2MHz available for communications with USAF radar facility to obtain weather advisory service

LW (Long Wave)

This set covers 150-400 kHz. Non-Directional Beacon and Range Beacon signals. These stations identify themselves at 30-second intervals with call letters in Morse Code. Their signals are used for airway direction finding.

Range Beacon, called Radiorange 4 Course Beacon, transmits A and N Morse Codes for determination of 4 airway courses.

These beacon bands also broadcast weather information at 15 and 45 minutes after the hour from FAA Weather Navigation Stations. When necessary, they broadcast flash warnings of approaching dangerous weather.

Some stations now offer continuous weather service. These beacon bands include in their transmissions weather information to yachtsmen, boat owners, fishermen, etc.

SW-1

This band covers 1.6-3.5 MHz (187-86 m), where you can receive amateur radio transmissions, marine information, and broadcasts in tropical areas.

SW-2

Covers 3.5-9.0 MHz (86-33 m). Marine information and amateur radio transmissions as well as domestic SW broadcasts can be received.

SW-3, SW-4, SW-5

These SW bands provide world-wide coverage. You can intercept amateur radio transmissions on the 14 MHz band and also 21 MHz band, and international broadcasts at 9 MHz, 11 MHz, 15 MHz, 17 MHz and 21 MHz.

For further details, refer to the supplied "Short Wave Guide".

DIRECTION FINDING

This set can be used as a radio direction finder to pinpoint your location with respect to beacon or broadcast transmitters. This makes the set a very useful navigation tool for small boat operators, pilots, etc. A simple method for radio direction finding is as follows.

1. Turn the RF GAIN control clockwise and set the radio into manual gain control mode.
2. Tune in a MW or Beacon (LW) station whose location is known until the Tuning meter needle of this set swings furthest to the right. Then rotate the set horizontally until the meter returns to or near zero.
3. Hold the set at this angle (bearing) and take a reading of the bearing.
4. Draw a line through the location of the transmitter. Your location is somewhere along the line.
5. Repeat step 1-4 using another station whose location is also marked. This will give you a pair of lines. Your location will be at the intersection of these lines.

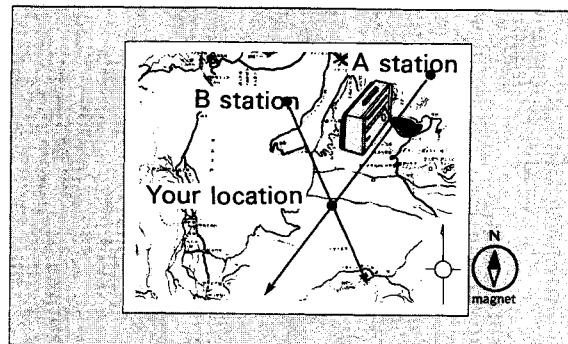

SPECIFICATIONS

Semiconductors:

- 13 transistors for reception
- 7 transistors for auxiliary circuits
- 1 SONY Light Emitting Diode

Frequency range:

- FM 87.5 — 108 MHz (3.42-2.78 m)
- MW 530 — 1605 kHz (566-187 m)
- LW 150 — 400 kHz (2000-750 m)
- SW1 1.6 — 3.5 MHz (187-86 m)
- SW2 3.5 — 9.0 MHz (86-33 m)
- SW3 9.0 — 14.0 MHz (33-21 m)
- SW4 14.0 — 21.0 MHz (21-14 m)
- SW5 21.0 — 26.0 MHz (14-11 m)
- AIR 108 — 136 MHz (2.78-2.21 m)

Antennas:

- FM/SW/AIR Telescopic antenna
- MW/LW built-in ferrite bar antenna
- External antenna terminals for FM/AIR
- External antenna terminals for MW/LW
- External antenna terminals for SW

Speaker:

- 4" × 6"

Power output:

- 1.8 W (undistorted)
- 2.7 W (max.)

Current drain:

- 40 mA (at zero signal)
- 260 mA (at 1.8 W output)

Power requirement:

- DC 12 V (8 size D batteries)
- AC 120 V, 60 Hz

Dimensions:

- 13 $\frac{3}{8}$ × 9 $\frac{1}{16}$ × 6 $\frac{5}{16}$ " (w/h/d)

Weight:

- 14 lb 8 oz

Supplied accessories:

- earphone, AC cord,
- Short wave guide

Optional accessory

- Car battery cord DCC-2AW

Hz (Hertz): cycles per second

Design and specifications are subject to change without notice.