

BOTTOM VIEW OF TUBE SOCKETS

ILN5 R.F.

ILA6 CONVERTER

ILN5 I.F.

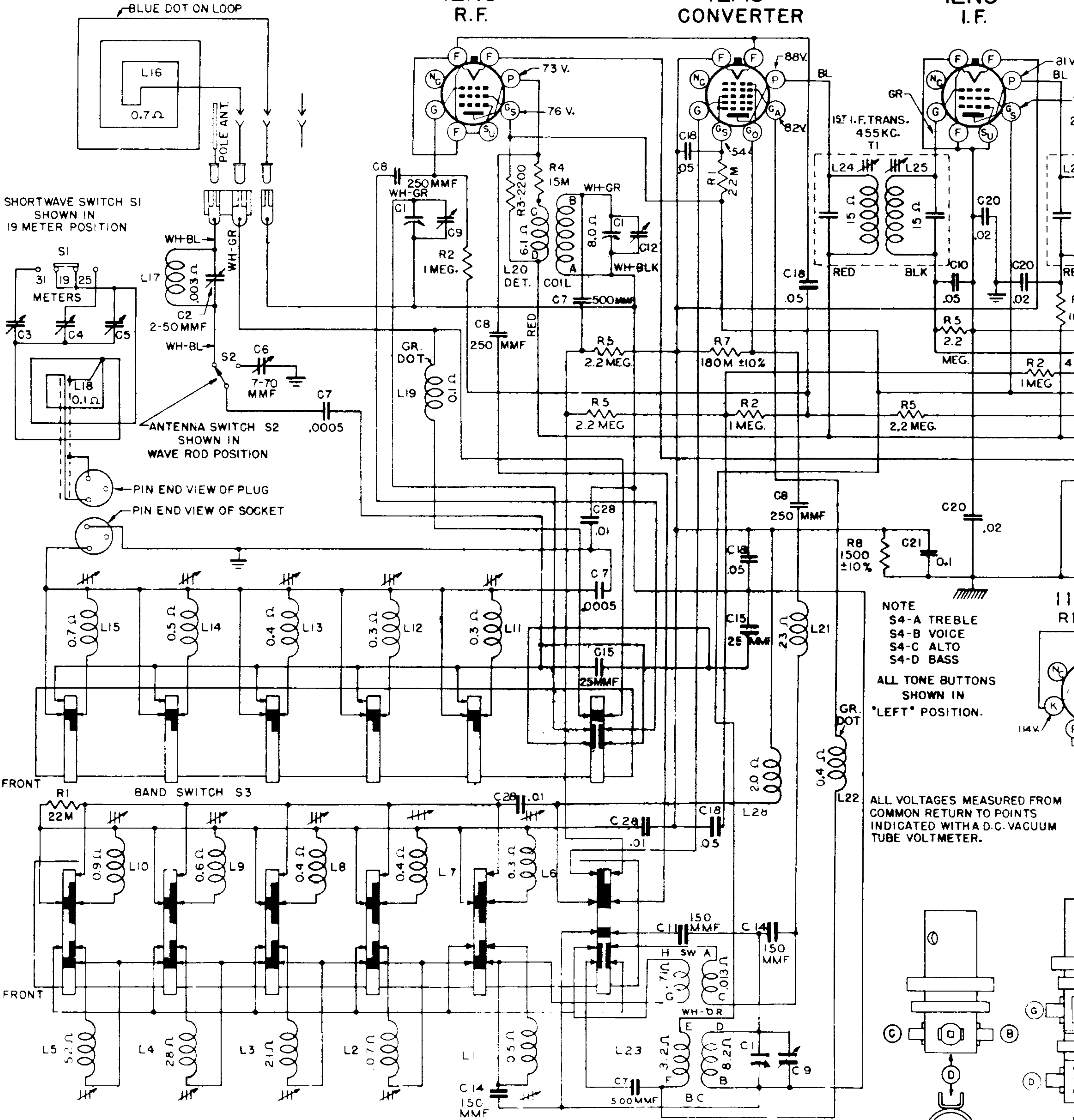

NOTE
 S4-A TREBLE
 S4-B VOICE
 S4-C ALTO
 S4-D BASS
 ALL TONE BUTTONS SHOWN IN "LEFT" POSITION.

ALL VOLTAGES MEASURED FROM COMMON RETURN TO POINTS INDICATED WITH A D.C. VACUUM TUBE VOLTMETER.

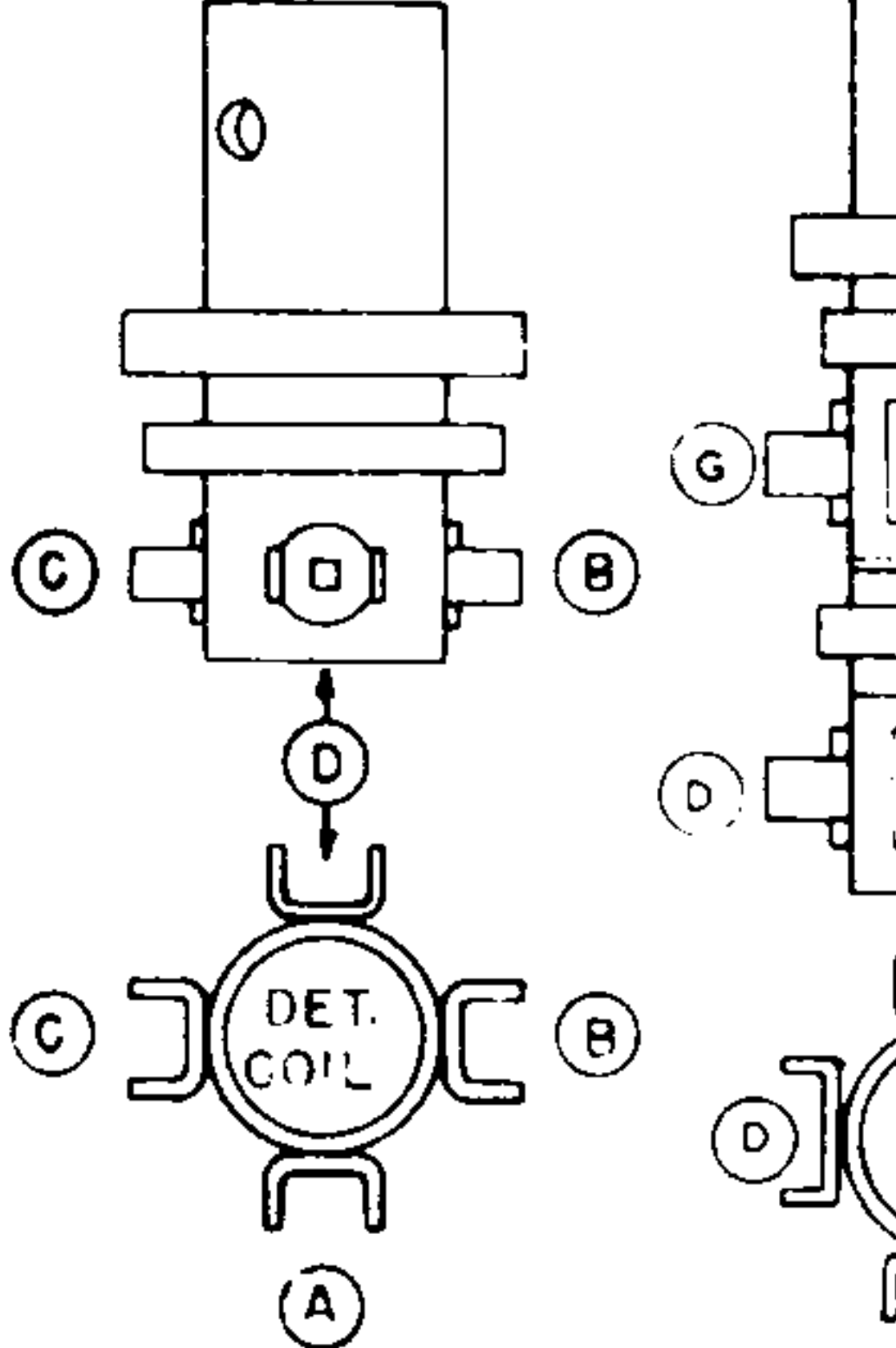

BAND SWITCH BUTTONS SHOWN IN NON-OPERATED POSITION.

ALL RESISTORS ±20% TOLERANCE UNLESS OTHERWISE SPECIFIED

⏏ DENOTES B-

⏏ DENOTES CHASSIS

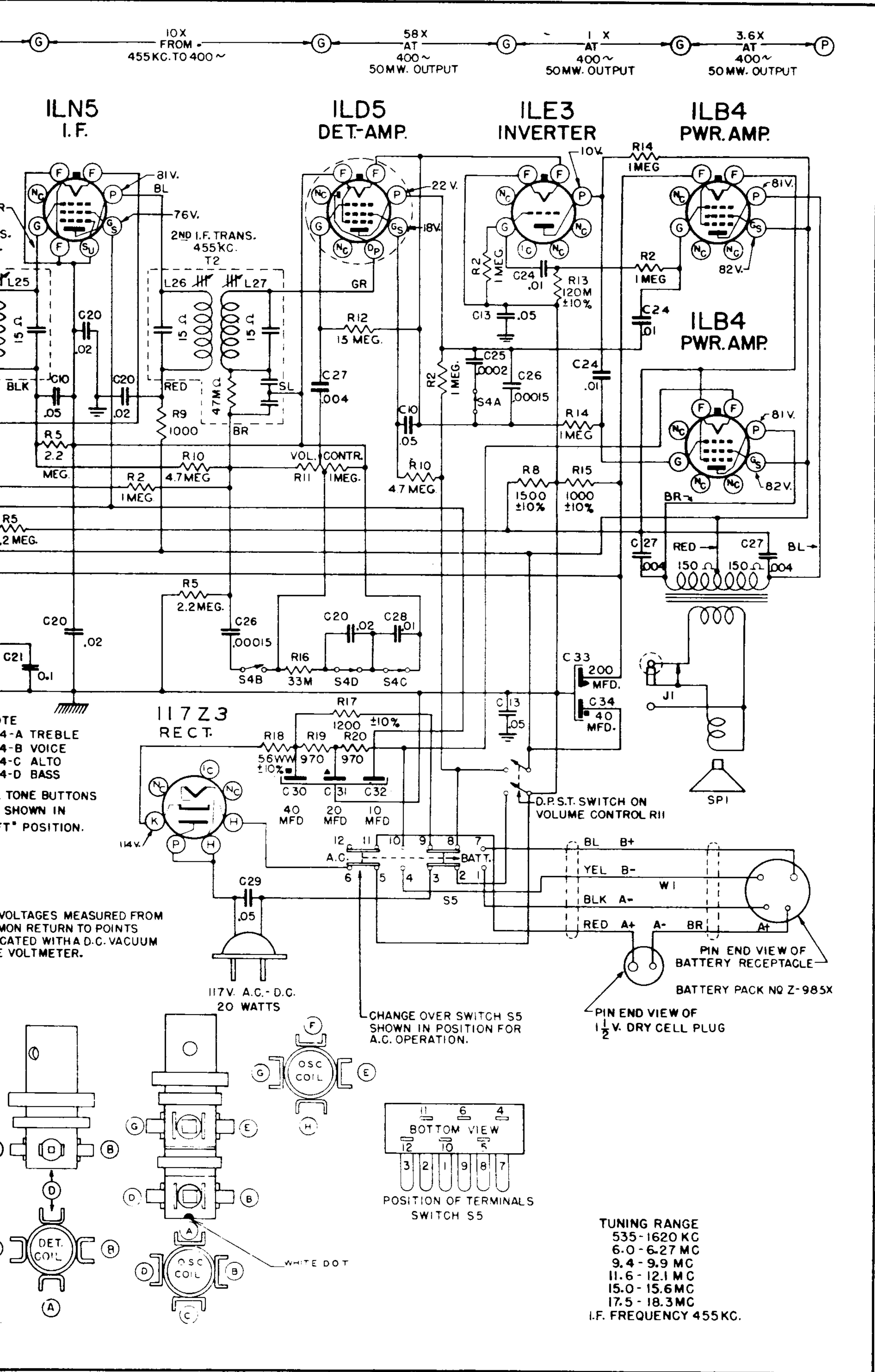

MODELS 8G005YT (Z1) — 8G005YT (Z2)
CHASSIS 8C40T (Z1) — 8C40T (Z2)

MODELS 8G005YT (Z1) — 8G005YT (Z2)
CHASSIS 8C40T (Z1) — 8C40T (Z2)

TO THE SERVICE MAN:

Chassis 8C40T (Z1) and 8C40T (Z2 Special Weather Band) feature a high gain tuned RF stage ahead of a conventional super-heterodyne circuit with band spread tuning on the 49, 31, 25, 19, and 16 meter bands.

The audio amplifier used in these chassis features phase inversion and push-pull power output.

If removal of the chassis from the cabinet ever becomes necessary this should be done with care.

The alignment of these chassis is conventional. However, care must be exercised when making adjustments, and the alignment procedure must be followed exactly. Set the chassis over a metal plate approximately the same distance the battery pack is from the bottom of the chassis when it is in the cabinet. This procedure will introduce the approximate amount of metal in the field of the RF and oscillator coils as when the chassis is in the cabinet. A signal generator of reasonable accuracy and good attenuation must be used. An output meter (AC) of the copper oxide rectifier type with a range of 1 to 30 volts in several steps is necessary to get accurate output readings. Alignment wrenches should be of the non-metallic type, especially when making adjustments at the higher frequencies.

When reinstalling the chassis in the cabinet be careful not to disturb the cabling between the short wave coil assembly and chassis. Tune in a weak broadcast signal near 1400 Kc. and touch up trimmer C9. This will insure maximum performance after alignment.

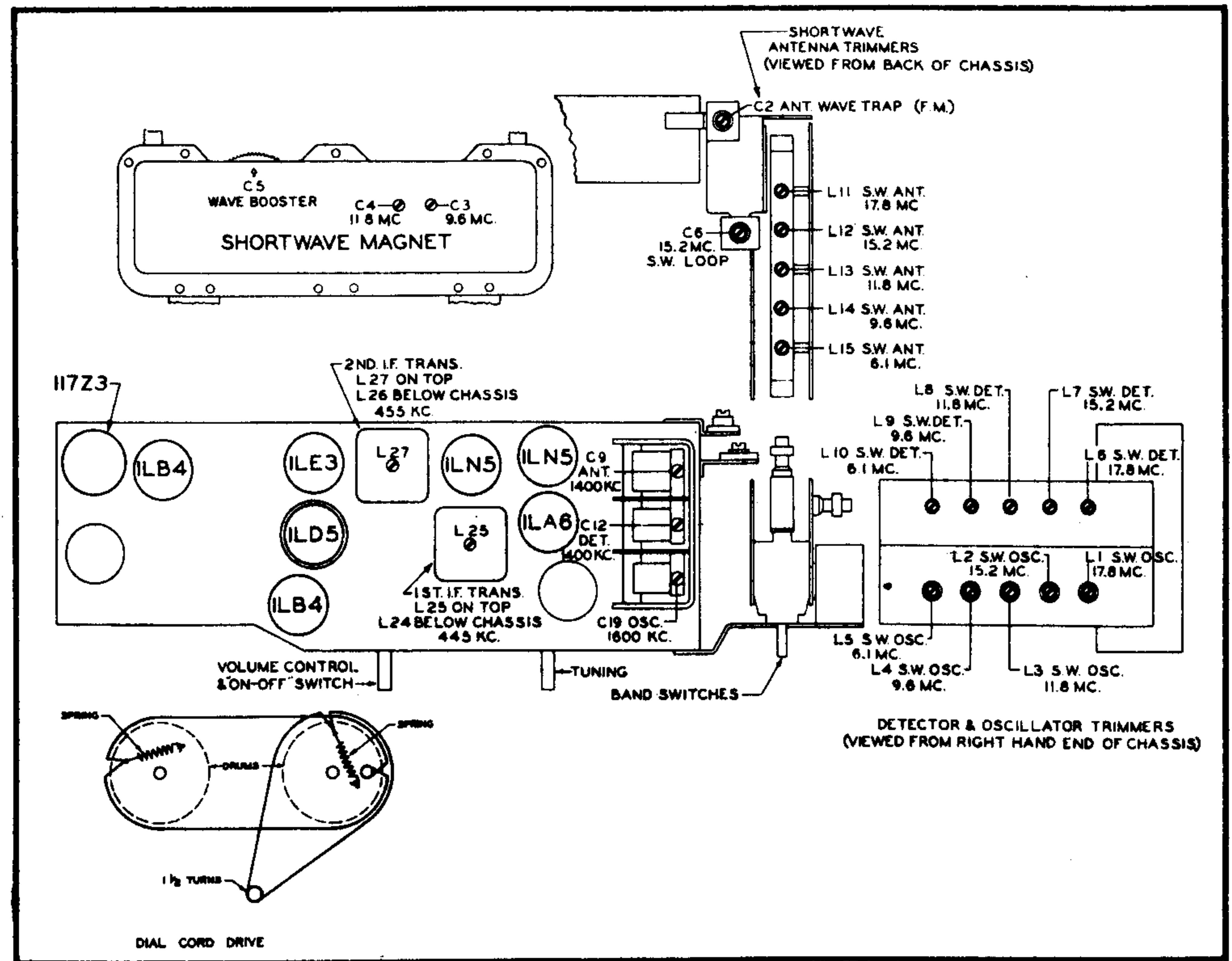

TUBE, TRIMMER LOCATION AND DIAL CABLE DRAWING
ALIGNMENT PROCEDURE

OPERATION	CONNECT OSCILLATOR TO	DUMMY ANTENNA	INPUT SIG. FREQUENCY	BAND	SET DIAL AT	TRIMMERS	PURPOSE
1	Converter Grid	.1 mfd.	455 Kc.	BC	600 Kc.	L-24, 25, 26, 27	Align I. F.
2	One Turn Loop Coupled Loosely to Broadcast Wavemagnet		1600 Kc.	BC	1600 Kc.	C-19	Set Oscillator to Scale.
3			1400 Kc.	BC	1400 Kc.	C-12	Alignment of Detector Sec.
4			1400 Kc.	BC	1400 Kc.	C-9	Alignment of B. C. Wavemagnet
5*	For 8C40T (Z2)		6.1 Mc. 6.5 Mc.	49 Met. 49 Met.	6.1 Mc. 6.5 Mc.	L-5, L-10, L-15	Alignment of S.W. Antenna, Detector and Oscillator
6*	3 Feet of Wire, Approx. 1 foot from Extended Waverod		9.6 Mc.	31 Met.	9.6 Mc.	L-4, L-9, L-14	
7*			11.8 Mc.	25 Met.	11.8 Mc.	L-3, L-8, L-13	
8*			15.2 Mc.	19 Met.	15.2 Mc.	L-2, L-7, L-12	
9*			17.8 Mc.	16 Met.	17.8 Mc.	L-1, L-6, L-11	
10	One Turn Loop Coupled Loosely to Shortwave Magnet, Waverod Collapsed.		15.2 Mc.	19 Met.	15.2 Mc.	C-5, C-6	Alignment of Shortwave Magnet.
11			11.8 Mc.	25 Met.	11.8 Mc.	C-4	
12			9.6 Mc.	31 Met.	9.6 Mc.	C-3	
13	When Receiving Normal Transmission on the 49, 31, 25, 19 or 16 Meter Bands, if FM Interference is Experienced Adjust Wave Trap Trimmer C-2 for Minimum Response of the Interfering Signal.						

* NOTE: Rock Tuning Condenser When Making Alignment Under Operations 5, 6, 7, 8 and 9.