

# DX-70

## Service Manual

---

---

### CONTENTS

---

---

● SPECIFICATIONS.....	1
● CIRCUIT DESCRIPTION.....	2
● SEMICONDUCTOR DATA.....	12
● EXPLODED VIEW .....	21
● PARTS LIST.....	28
● ADJUSTMENT.....	42
● PC BOARD VIEW.....	49
● BLOCK DIAGRAM.....	58
● CIRCUIT DIAGRAM.....	59
● EDX-1.....	65

# SPECIFICATIONS

## 1) General

Operating mode	J3E(LSB,USB), A1A(CW), F3E(FM)	
Number of memory channels	100	
Antenna impedance	50 Ω unbalanced	
Power requirement	13.8 V DC ± 15% (11.7 to 15.8 V DC)	
Grounding method	Negative ground	
Current drain	Receive	1.0 A max.
	Transmit	20 A max.
Operating temperature	-10 °C to +60 °C	
Frequency stability	± 10 ppm (-10 °C to +50 °C)	
Dimensions	178(w) × 58(h) × 228(d) mm (179 × 71 × 268 mm for projections included)	
Weight	Approx. 2.7 kg	

## 2) Transmitter

Transmit frequency coverage (e.g. U.S. Version)	160 m band	1.8000 to 1.9999MHz	
	80 m band	3.5000 to 3.9999MHz	
	40 m band	7.0000 to 7.2999MHz	
	30 m band	10.1000 to 10.1499MHz	
	20 m band	14.0000 to 14.3499MHz	
	17 m band	18.0680 to 18.1679MHz	
	15 m band	21.0000 to 21.4499MHz	
	12 m band	24.8900 to 24.9899MHz	
	10 m band	28.0000 to 29.6999MHz	
6 m band	50.0000 to 53.9999MHz		
Power output	HF band	SSB, CW, FM	100 W (high) Approx. 10 W (low)
		AM	40 W (high) Approx. 4 W (low)
		SSB, CW, FM	10 W (high) Approx. 1 W (low)
	50 MHz band	AM	4 W (high) Approx. 0.4 W (low)
		SSB, CW, FM	10 W (high) Approx. 1 W (low)
		AM	4 W (high) Approx. 0.4 W (low)
Modulation system	SSB	Balanced modulation	
	AM	Low power modulation	
	FM	Reactance modulation	

## Transmitter (continued)

Spurious emission	HF bands	Less than -50 dB (-45 dB in 10 MHz band)
	50 MHz band	Less than -60 dB
Carrier Suppression	More than 40 dB	
Sideband suppression	More than 50 dB (at 1 kHz)	
Maximum FM deviation (default)	HF bands	± 2.5 kHz
	50 MHz band	± 5 kHz
Microphone impedance	2 kΩ	

## 3) Receiver

Receiver circuitry	Double conversion superheterodyne		
Receive frequency range	0.1500 MHz to 30.0000 MHz, 50.0000 MHz to 54.0000 MHz		
Intermediate frequency	71.75 MHz (1st)	455 kHz(2nd)	
Sensitivity	SSB, CW (S/N 10 dB)	0.5 to 1.8 MHz	0 dB (1 μV)
		1.8 to 30 MHz	-12 dB (0.25 μV)
		50 to 54 MHz	-16 dB (0.15 μV)
	AM (1 kHz, 30% Mod, S/N 10 dB)	0.5 to 1.8 MHz	+20 dB (10 μV)
		1.8 to 30 MHz	+6 dB (2 μV)
		50 to 54 MHz	+6 dB (2 μV)
FM (1 kHz, 3.5kHz, DEV, SINAD 12 dB)	28 to 30 MHz	-6 dBμ (0.5 μV)	
	50 to 54 MHz	-10 dBμ (0.3 μV)	
Selectivity	SSB, AM(Narrow)	2.4 kHz/-6 dB, 4.5 kHz/-60 dB	
	SSB(Narrow), CW(Standard)	1.0 kHz/-6 dB, 3.0 kHz/-60 dB	
	CW(Narrow)	500 Hz/-6 dB, 3.0 kHz/-60 dB	
	AM(Standard), FM	9 kHz/-6 dB, 20 kHz/-50 dB	
Superiors and image rejection ratio	More than 70 dB		
Audio output power	More than 2.0 W (at 8 Ω, 10% THD)		
RIT/TXIT range	± 1.4 kHz		

# CIRCUIT DESCRIPTION

## 1. Receiver System

### 1) Filter Unit

#### a. HF Antenna Input

SA501 and R527 are installed in the input part of HF antenna terminal as the countermeasure against the thunder.

The electric charge of HF antenna is discharged at R527, and when the voltage becomes over about 300V, the gap of SA501 is discharged so that the receiving input circuit is protected.

The input signal from HF antenna is passed through the transmission/reception selecting relay RL513. The followings are prevented in LPF consisting of L525, L526, C580, C581 and C582: 2m band image receiving, passing through the First IF (71.75MHz) and leaking of the first local oscillating frequency (72~130MHz) to the antenna terminal.

#### b. 50MHz Antenna Input

The receiving signal from the antenna of 50MHz band is passed through the LPF for transmission/reception and passed through the transmitting power detection circuit, then led to transmission/reception switching circuit consisting of D508 and D509, and to HPF. The signal is amplified about 8dB in Q503. Because the space noise in 50MHz band is less than it in HF band, its exclusive receiving preamplifier is equipped to get high sensitivity.

The receiving signal of 50MHz or HF is selected in RL514, then after passing through the attenuator circuit (ON/OFF) of about 20dB consisting of RL515, R528 and R531 the signal is led to the Main unit.

## 2) Main Unit

### a. Front End

The receiving signal output from Filter Unit is led to Main unit through CN2. HPF, consisting of L19, L20, C47, C48, C49, C50, C51 and C52, eliminates the strong radio signal of MW band of 1.6MHz or below. In case of receiving the signal of 1.6MHz or below, the sensitivity is controlled by the attenuator in R37 and BPF1, also the signal is separated into 1.6MHz, over or below. 5 BPF units consists of 9 filters. Each filter covers the following frequency range. The frequency of 2.5MHz or more consists of Chebyshev BPF, and under 2.5MHz frequency band is LPF. Two BPF's are installed on the same unit. Not to be influenced so much, the distant frequency band BPF's are combined.

- 1.6MHz	BPF1	
1.6 - 2.5MHz	BPF2	1.8MHz
2.5 - 4.5MHz	BPF3	3.5MHz
4.5 - 7.5MHz	BPF4	7MHz
7.5 - 10.5MHz	BPF1	10MHz
10.5 - 14.5MHz	BPF2	14MHz
14.5 - 21.5MHz	BPF3	18, 21MHz
21.5 - 30MHz	BPF4	24, 28MHz
50 - 54MHz	BPF5	50MHz

Passing through BPF, the signal turns ON/OFF in the switching diode, D29 and D30. This preamplifier is the parallel grounded gate operation of Q9 and Q10 (2SK2171), so the unit can obtain a good performance at a high level input signal with low NF.

The wide range frequency from about 1MHz to 60MHz is amplified about 10dB. This 10dB preamplifier and 20dB attenuator in the Filter unit are combined, then by pressing RF gain switch on the front panel, one of four steps, -20, -10, 0, or +10dB is selected.

The LPF, consisting of L52, L53, L54, C103, C104, C105, and C106, prevents the following first receiving mixer from the local oscillation leaking, and also prevents the first IF and image of the spurious receiving.

The first receiving mixer consisting of Q10 and Q11 is the balanced mixer, in which the local oscillating signal is led to the gate of 2SK2171.

The 3rd intercept point is about 20dBm, and local oscillator of about 2V P-P is fed to the gate. The receiving signal is converted into the first IF of 71.75MHz.

As the ratio of the spurious interference is decreased in 50MHz band mode, the trap of 71.75MHz consisting of L72 and C107 keeps the ratio of spurious interference 70dB or more in all band.

### b. The First IF Amplifier Circuit

FL1: A and FL1: B are the crystal filters of 71.75MHz. By the combination of two filters, the unit has the characteristics of the band width of 15kHz or more/3dB and the value of guaranteed attenuation of 70dB or more. Here the image ratio is determined 70dB or more (approx. 80dB). The first IF amplifier circuit of Q12 is located between the crystal filters to prevent the loss in the front-end and mutual interference.

The first IF amplifier circuit Q12 decides the sensitivity after passing the mixer. AGC voltage is applied to the second gate.

### c. The Second Mixer Circuit, The Second Amplifier Circuit

DBM (Double Balanced Mixer) consists of L14, D7 and L16. The signal is passed in the opposite direction while receiving or transmitting in this DBM. Approximately 0dBm is fed as the second local oscillating level, and the third IP is approximately 10dBm.

The receiving signal (71.75MHz) and the second local oscillating frequency (71.295MHz) is mixed, and unwanted signal is eliminated in LPF consisting of L17, L73 and C36, then the signal of 455kHz is generated. After passing through the switching diode DB, the signal is amplified in Q22. The source of Q22 is controlled by the output of the noise blanker circuit.

### d. IF Filter

After passing through the transmission/reception switching diode D9, the signal is led to one of three ceramic filters of 455kHz. The selectivity is decided here except CW narrow.

SSB, AM-NARROW	FL3(CFJ455K5)	2.4kHz/-6dB	4.5kHz/-60dB
SSB-NARROW, CW	FL2(CFJ455K8)	1.0kHz/-6dB	3.0kHz/-60dB
FM, AM	FL4(CFW455G)	9kHz/-6dB	20kHz/-50dB

Each filter has 4 switching diodes (D3~D4B) in front and rear to isolate the filter.

The isolation is required the value of guaranteed attenuation of each filter (approx. 70dB) or more. The diode connected in parallel in front and rear of no used filter is short and the diode connected in series is open. The combination of open and short is used to get the high isolation. The modes, transmission/reception and wide/narrow of this filter are selected by Q36-Q46, D79, D80, D82, D83, D84.

#### e. The Second IF Amplifier Circuit

After passing through the filter, the signal is led to the transmission/reception switching diode D49, and amplified in Q23 and Q24, then buffered in Q25. The AGC voltage is applied to the second gate of Q22, Q23 and Q24. The output level of Q25 is fixed because the AGC voltage is added to the receiving signal. This output signal is used for the demodulation in SSB, AM and CW modes and AGC detection. In the FM mode, after passing through the transmission/reception switching diode of D49, a part of receiving signal is led to IC7(MC3357) from C221, then it is IF-amplified and demodulated. C214 is connected in parallel to the feedback resistor R182, and the resistor is de-emphasized. Even in the FM mode, Q23, Q24 and Q25 are active, also AGC is operated.

#### f. Demodulation Circuit

In SSB and CW modes, the following local oscillating frequency is supplied from PLL unit to IC3 balanced mixer, then the signal is demodulated. The receiving signal is fed to Pin1, and local oscillation Pin3. then picked up the demodulation output of approximately 100mV from Pin7.

USB	456.5kHz	+IF	SHIFT
LSB	453.5kHz	+IF	SHIFT
CWU	455.8kHz	+IF	SHIFT
CWL	454.2kHz	+IF	SHIFT

The output is led to the switching circuit of each mode, and to the CW audio filter. In AM mode, the signal is detected in D51, then led to IC5. In FM mode, the signal is demodulated and de-emphasized in above-mentioned IC7, then led to IC5.

#### g. CW Audio Filter

IC4 is the active filter, which consists of the combination of low-pass filter and high-pass filter in the operational amplifier. It has the band width of about 600Hz (-6dB) centering the frequency of about 800Hz.

#### h. AF, AGC Time Constant Selection

IC5 is the analogue multiplexer which has 2 circuits with 4 contact points, and switches the demodulation output in every mode and AGC time constant. The voltage combined in D55 and D56 is input to Pin9 and Pin10, then the output of IC3 (SSB, CW-W), the modulation output of FM/AM and CW audio filter output (CW-N) are selected. The voltage of 8V is applied to Pin6 (INHIBIT) when transmitting, and the modulation output is turned OFF unconditionally.

#### i. AF Amplifier

The voltage that can pass through the analogue switch of IC5 is very low. The voltage is amplified approximately 20dB in IC12: B to get higher AF input voltage to following IC13 (voltage controlled electronic volume). Also a part of this output is picked up and output to Pin6 of microphone as non-squelched audio output. This output is used as the terminal of packet, RTTY, SSTV, etc.

#### j. Electronic Volume, AF Amplifier

IC13 is the dual electronic volume controlled by the voltage. The volume is controlled by the AF GAIN VR on the front panel. Pin5 is the control terminal. The value of the attenuation is the minimum when the control voltage is about 3.4V, and the value is 90dB or more at maximum when the control voltage is about 3.1V. One of the circuits is for volume control of the demodulation sound, and the other for the volume control of the beep and sidetone. The beep and sidetone can be heard even if the volume is set to the minimum point and sound tone is related with AF GAIN VR. The squelch circuit (IC14:A, Q14) controls Pin5. The output of IC14: A activates to close the squelch when transmitting, so Q14 is turned OFF in D85 to control the volume of the sidetone. The receiving sound is fed to Pin6 and applied from Pin7. As for the beep and side tones, Pin2 is for input and Pin1 for output. These two outputs are combined with the input of LPF amplifier IC12:A. The high tone noise that is generated in IF amplifier is decreased by LPF amplifier. The output of IC12: A is attenuated in R309 and R310 to get the same level with IC20, and also to decrease the noise. IC20 is the AF power amplifier which can get the output of 2W or more (THD 10%) at 8Ω load. The ripple filter consists of Q51 and C260.

#### k. AGC

The AGC voltage is supplied one stage to first IF amplifier and three stages to second IF amplifier. These IF amplifiers consist of 3SK131. AGC voltage is applied to the Gate2. The IF amplifiers are designed that the gain is changed linearly corresponding to the AGC voltage. D53 and D54 are the rectifier, and Q26 is DC amplifier. D50, the anode is set to about 2V in R176, D110, D111 and R177. Usually AGC voltage is applied 2.4V. The strong signal rectifies D53 and D54 resulting in DC voltage. Q26 decreases the AGC voltage. When AGC-FAST is selected in SSB/CW mode, C205 and C206 are connected between 5V and AGC line in parallel. The attack time of AGC is determined in R167 and C206, then the release time is determined in R168 and C206. The characteristics are "fast attack" and "slow release". In case of AGC-SLOW, the analogue switch IC6 is turned ON, then R175 and C287 are connected in parallel. The release time is lengthened because of C287. In case of AM, C206 is connected in parallel, then the attack time is delayed, which is the average type. D110 and D111 is the thermal compensation of D50. In receiving AM, AGC is the average type not to follow the modulation.

### i. S Meter, Squelch

The output of Pin1 and RF meter output are combined in the diode, then it is sent to the front CPU to display the meter. The output signal of Pin1 is fed to Pin6 of IC14:A. The voltage of Pin5 is determined by the squelch VR of front unit. Comparing with this voltage, the squelch is opened or closed.

While the check operation the CPU output decreases the voltage of squelch VR in front side to open the squelch forcedly. The squelch output controls IC13, at the same time it is provided to the front unit to light RX LED and led to CPU unit.

### m. Noise Blanker Circuit

This circuit eliminates the pulse noise of a car, etc. Because the noise emitting time is short, in this duration the operation of receiver is stopped to prevent the unit from emitting a noise. The pulse noise is delayed when it is passed through the narrow band filter, and the emitting time becomes longer. It makes difficult to eliminate the noise, so it is necessary to eliminate the noise in the earlier stage.

A part of the second mixer output, whose band width is limited, is amplified in Q20, Q19, Q18, and Q16. The signal is detected in D33 and D34, and the AGC voltage is applied to Q19, Q18 and Q16.

The charge time constant of this AGC is determined by R82 and C128, and also the discharge constant is determined by R81+R82, C128. The voltage of AGC does not rise suddenly because of the charge constant, so that this voltage is not applied to almost all the short signals such as pulse noise, but is applied to the continuous signals such as receiving signal and amplifier gain is decreased.

While emitting the pulse noise, the AGC voltage does not follow the pulse noise, so the detected voltage is high, then Q15 is turned ON in that time.

On the contrary, as for the continuous signal, the detected voltage of D33 and D34 is fixed by AGC, so Q15 is turned OFF because of the emitter bias of R85 and R84.

Namely Q15 is turned ON only the time of the pulse noise, then Q21 is turned OFF. The source of IF amplifier of Q22 is biased through R98 and R102 so that the gain is decreased and the signal is blanked. When the emitter of Q15 is biased to high, the Noise Blanker is turned OFF.

## 2. Transmitter System

### 1) Main Unit

#### a. Microphone Amplifier

The input signal from microphone is amplified by the low noise amplifier Q56 through the mic gain VR1. It is possible to bias (8V) the microphone terminal with R388 for the microphone which needs the power supply. (solder bridge)

In SSB/AM mode, The gain of IC21 (approx. 15dB) is determined by R329 and R328.

In FM mode, R330 is connected to R320 in parallel by Q55, then the gain is increased approximately 34dB. Also the cut off frequency is risen, and the signal is pre-emphasized and operated as a limiter.

In the SSB/AM mode, C345 and R384 are connected to the feedback circuit by Q63 when the speech compressor is turned ON. The gain is increased about 15dB, then IC21:B is operated as the limiter.

When the speech compressor is ON, the low frequency is cut by C345.

In FM mode, the gain is risen enough, so the speech compressor has no effect.

The output of Pin1 of IC21: B is attenuated in R326 and R325. The subaudible tone from PLL unit is applied through R325. (When the Tone is ON.)

IC21: A is LPF amplifier that is the Splutter filter in FM mode, and it is operated for speech compressor.

This signal is output to PLL unit as the FM modulation, and output to the balanced modulation of IC2.

The output to IC2 is muted by Q54 in CW/FM mode.

#### b. Balanced Mixer

IC2 is the balanced mixer, and the carrier is suppressed in SSB mode. To get more ratio of carrier suppression, the balance adjustment of VR3 and VR4 are applied.

The carrier is necessary in CW/FM/AM mode, so the input of Pin1 is made unbalanced by applying the DC voltage to obtain the carrier.

By applying the DC in AM/FM mode, or by keying in CW mode, the balance is broken to obtain the carrier wave. VR11 is used for the adjustment of carrier level. In the AM mode, the DC and modulation is added simultaneously. In SSB mode, the modulation is added by R317. In AM mode, D93 is DC-biased and turned ON. Then the attenuator consisting of R317 and R393 limits the modulation.

#### c. IF Filter

After the output of IC2 increases the impedance in C177 and L77, it is passed through D49 and led into band limit IF filter. D52 is isolated highly by connecting to the output in parallel at receiving. In SSB mode, the output is DSB signal. (Double Side Band)

The filter is switched by the selection of above-mentioned diode switch. The signal is passed through the following filter in each mode.

SSB	FL3(CFJ455K5)	2.4kHz/-6dB	4.5kHz/-60dB
CW	FL2 (CFJ455K8)	1.0kHz/-6dB	3.0kHz/-60dB
FM, AM	FL4 (CFW455G)	9kHz/-6dB	20kHz/-50dB

SSB is obtained by eliminating one of side bands of DSB through the filter.

#### d. IF Amplifier, The Second Mixer

After passing through the filter, the signal is led to D37, Q7, and D6, and passed through the second mixer in the opposite direction of the receiving, then the signal of 71.75MHz is obtained. Q6 operates the CW keying.

The voltage of ALC is added to the second gate of Q7.

The local oscillating signal of 71.295MHz and unwanted signal are eliminated in FL1: A and FL5. The signal is amplified in Q5, passed through FL5, then led to the balanced mixer of Q3 and Q4.

#### e. The First Transmitting Mixer

This mixer is the balanced type, and the unwanted signals (IF and local oscillating signal) are decreased. The best operation is selected by biasing the second gate. To decrease the spurious, the signal is balanced in VR1.

#### f. Power Amplifier

Passing through the mixer, the transmitting signal which has the desired transmitting frequency is passed after switching the LPF for HF band or BPF for 50MHz band. The unwanted signal and especially the leak of local oscillating signal is decreased as less as possible.

The signal is amplified up to 0~3dBm in Q1. T notch filter consists of C1, C2 and L1. It is tuned to approximately 44MHz while using 50MHz band to decrease the spurious signal. Then the signal is supplied to PA unit.

## 2) PA Unit

#### a. Power Amplifier

The signal input to PA unit is amplified up to approximately 100mW. The idling current of Q601 flows about 100mA during transmitting as A-class amplifier. The frequency characteristics are compensated by feedback, besides connecting the capacitor to emitter resistor in parallel.

The signal is amplified up to 10W in Q602 and Q603.

PA amplifier is the wide band range from 1.8MHz to 50MHz

The idling current flows 100mA (adjusted in VR601), and the amplifier is the push-pull type.

D601 is connected to Q602 and Q603 thermally, and the idling current is compensated for temperature. This output is switched at RL601 in 50MHz, then supplied to filter unit.

#### b. Final Stage Power Amplifier

In the final stage amplifier circuit consisting of Q604 and Q605 (2SC2904), the idling current of about 300mA is flowing. The base bias is made by Q606. D604 and D605 are connected to Q604, Q605 and Q606 thermally, and the idling current is compensated for temperature.

The feedback circuit, consisting of R621, R622, R623, C633, R627, R628 and C637, makes the gain flat in the wide range of 1.8MHz~30MHz.

The 100W output is led to filter unit.

The collector current of Q606 and Q607 is detected by using FB606 and L611. Then led to the main unit.

#### c. Fan Control

The heat of Q606 and Q607 is detected by the thermistor TH601, and the fan is controlled. While transmitting, the resistance value is decreased by the rising of the temperature, then the voltage of inverting input terminal of IC601A/B is decreased. Non-inverting input is applied with the voltage corresponding to the temperature. When the temperature goes up to about 50°C or more and the compared voltage becomes lower than the inverting input voltage, Q607 is turned ON by the output voltage of comparator, IC601: A. Then the fan starts turning at a low speed by the value of series resistor (R639).

When the temperature rises more and the voltage becomes much lower than the compared voltage IC601: B, Q608 is turned ON. Then R639 is turned OFF and the fan turns at a high speed according to the value of series resistor of R640 to decrease the compared voltage of IC601: A.

When the temperature goes up to about 100°C and the voltage is decreased further lower, IC601: A supplies again, then R639 and R640 are connected in parallel to turn the fan at a higher speed. Although ordinary PDWN is pulled up to 14V by R637, the power output is set to LOW because both cathode terminals of D608 become LOW when the fan turns at a high speed. Then the signal is sent to the main unit as the control signal for power down at high temperature.

As the compared voltage of IC601: B is decreased in D611 while receiving, IC601:B does not work if the temperature does not go up higher than it while transmitting. The temperature, at which the fan turns at a middle speed or more, is higher than it while transmitting. At high temperature, fan's turning speed comes down while receiving.

#### d. Protection Circuit

For the protection of the final power amplifier, the followings are equipped:

SWR detection

Protection against over current

Power down circuit for the temperature detection

#### e. CW Keying Circuit

As the base voltage of main unit Q49 goes down to LOW by CW keying, the voltage is supplied to collector. This output controls all of the circuit operation by CW keying.

The collector output of Q49 is passed through D95, VR11 and D93, and the balance is broken by applying DC voltage to the balanced mixer to generate the carrier. VR11 determines the CW waveform of rise and fall by adjusting the carrier level in R285 and C248.

At the same time Q48 is turned ON to turn OFF Q6 for keying isolation. C244 makes the OFF time of Q6 longer not to influence the keying waveform.

The voltage is applied to IC17: B Pin5 in D95, and the output of Pin7 turns Q46 ON to set PTT line to LOW in D73, then the unit enters the transmitting mode. The capacitor (C246, C247) is connected between Pin5 of IC17: B and the ground. The holding time of transmitting is determined according to the discharge time constant. BK1, BK2, and BK3 are the voltages for the setting of 3-bit break-in time constant. 8 stages voltage is obtained by the combination of the resistors R269, R270 and R271.

In the Full Break-in mode, all of BK1, BK2 and BK3 are set to LOW, in the Semi Break-in mode, one of BK1, BK2, or BK3 is applied the voltage.

When all of the breakers are applied the voltage, it is used as the shortest time constant.

When in the full break-in mode, all of the voltages of BK1, BK2 and BK3 are low level, and Q47 is turned OFF. Therefore only C246 is the very short discharge constant, it is the full break-in mode with short transmitting time. One of BK1, BK2 and BK3 is supplied the voltage, and Q47 is turned OFF, then connected to C247 and C246 in parallel. The discharge time constant is longer, and it is the semi break-in time constant.

There are 7 stages of the voltage in the semi break-in mode according to the output voltage of BK1, BK2 or BK3. This is applied to the compared voltage of IC17: B, then the discharge time constant is changed. Namely when the voltage is applied to all of BK1, BK2 and BK3, the time constant is the shortest.

When the break-in mode is set to AUTO, BK1 only is supplied, and the compared voltage of IC17:B is controlled by the output voltage of IC17: B.

In the AUTO mode the keying output is emitted by one-shot multivibrator consisting of IC18A and B whenever the key is pressed. Therefore the average value of the output voltage of IC18: A is in proportion to the average speed of keying. To obtain the average voltage in R281, C245, etc., integrate the voltage. Then this output is D/C amplified in IC17:A, and provided as the compared voltage of keying. D97 is used for OFF in the AUTO mode. When the AUTO mode is in the LOW level, the voltage charged in C245 is short, then the operation in AUTO mode is stopped.

D107 and R360 are used to get up speed rising when the keying is started. D92 and R280 determine the discharge time constant. While receiving the time constant is prolonged.

The selection of transmission/reception follows the keying speed from 30 letters/minute to 200 letters/minute.

The transmitting mode is held between letters, and the unit returns to receiving mode between words.

#### f. Power Control, ALC Circuit

The forward wave voltage in proportion to the transmitting power obtained in filter unit is inverting-input to IC8:A, and inverting-amplified. Non-inverting input is applied the voltage, and the output voltage is shifted by the non-inverting input voltage.

ALC line is applied the voltage of about 2.7V beforehand, and the ALC voltage is supplied to the second gate of the amplifier.

When the forward wave voltage is detected, the output voltage of IC8: A is decreased. If it is about 3V or below, the ALC line voltage is decreased by D63. VR7 is used for the adjustment of 100W. When the unit is switched to 50W by S1, Q27 is turned ON and VR5 is connected in parallel to decrease the voltage, then the unit is adjusted to 50W.

In AM mode, R195 is connected in parallel to decrease the voltage up to about 40W.

In the low power mode, R191 is connected in parallel by setting to LOW, and the voltage is decreased.

Q29 and VR8 are used for the adjustment to get the required power of about 10W in the matching operation of external automatic tuner. (The required power depends on the tuner.)

When the value of SWR is high, the reflected wave voltage turns Q28 ON to decrease the power. The unit is operated when the SWR is about 3 or more.

Compared with the forward wave detection power in HF band of 100 W, the forward wave voltage in 50MHz band of 10W is set to higher a little.

In SSB mode, "fast attack" is obtained by D63, and the release time of "slow attack" is obtained by C222 and R130. In AM mode C221 is connected in parallel by Q30, and the unit is operated in near the average value.

#### g. Over Current Protection Circuit

The final stage collector current which is detected in PA unit is differential-amplified in IC8: B. The output voltage is decreased according to the increase of the current. Then ALC line is fallen by D63 and the output power is decreased. The operational point is decided in VR6.

#### h. RF Meter Circuit, ALC Indication

The forward wave is amplified in IC9: A to obtain the meter output voltage.

The peak is held in D70, R223 and C223, and the meter swings smoothly.

Meter output voltage and S meter output voltage are switched in D71 and D86 automatically.

ALC voltage is inverting voltage amplified in IC9: B.

This output is applied to the base of Q31, then sent to front unit for the detection of transmission/reception and lighting the transmitting LED. The LED brightness is changed according to the ALC voltage.

#### i. Sidetone Circuit

The comparison frequency of the second local oscillator in PLL unit (65kHz~85kHz) is divided by 10 in IC174, then led to the main unit. In addition the frequency is divided by 10 in IC19 of the main unit to obtain the sidetone of 650Hz~850Hz. The comparison frequency of the second local oscillator is changed according to the CW offset setting. To relate with the sidetone, comparison frequency is about 100 times the CW offset. IC19 Pin2 is controlled by Q65 at CW keying. The time constant is delayed not to give the influence to waveform of the sidetone.

The following active filter Q50 makes the square wave to sine wave to obtain better sound. The rise/fall wave of the sidetone is generated by keying controlling the bias of base and emitter.

#### j. Tune Circuit

When using the external automatic antenna tuner, this circuit controls the matching start signal and the operation of the unit during tuner matching.

When the tune operation is started, the Tune voltage is supplied to operate the one-shot multivibrator in IC18: C, D. The voltage of about 8 V is applied to outside for a fixed time through Q52 as the start signal. In the other hand, Q53 supplies the tune voltage of sink output, it becomes LOW while tuning. (For the transceiver made by ICOM, KENWOOD).

As soon as the tuner receives the tune start signal, the tuner provides it as the tuning signal. (TKEY terminal)

CPU observes the TKEY terminal, and keeps the unit in TUNE mode indicating that the tuner is operating while it is in the LOW level. CPU releases the TUNE mode when TKEY terminal is in LOW for 20 seconds or more. In the Tune mode the unit transmits a signal in AM mode, the microphone output is muted, then the carrier is kept on outputting about 10W (adjustable).

### k. Regulated Power Supply Circuit

IC11 is the 8V Regulated Power Supply Circuit. T8V that is necessary for transmitting is made in Q33, and R8V that is necessary for receiving is made in Q35. IC10, Q32 and Q34 control the transmission/reception. When PTT line is connected to the ground through the microphone terminal or CW keying output (Q46), H level is supplied from IC10: A and it is led to CPU of front unit to detect the transmission/reception switching.

IC10: C delays the rise of receiving in R227, C224 and D62 and controls in Q32 and Q33.

While receiving, the current is flowing from 13.8V through R230 and D75, then the base voltage Q33 is approximately 8.7V, and the emitter output is just 8V.

While transmitting, the base voltage of Q33 is 0V because Q32 is turned ON, and R8V is not provided.

While transmitting R8V is short by D77, and it makes the charge voltage such as electrolytic capacitor discharge momentarily not to remain R8V.

As for Q35, as same as R8V the current is flowing from 13.8V through R230 and D75, then the base voltage of Q35 is approximately 8.7V and the emitter output is just 8V while receiving. While transmitting, the base voltage is 0V because Q34 is turned ON, and T8V is not provided.

While transmitting T8V is short by D77, and it makes the charge voltage such as electrolytic capacitor discharge momentarily not to remain T8V.

After delayed the transmitting rise time in IC10:B, the signal is inverted in IC18:D, then T8V is controlled in Q34.

When Pin8 IC10:A is supplied the voltage, the unit enters PTT lock mode without changing the output of Pin10 even if the PTT line is connected to the ground.

### i. Mode Voltage, Function Control (BPF/ LPF Selector)

The enable terminals of IC15 and IC16 select the signal ENX or ENY by using IC24 and Q62.

The data from CPU (DAT2) consists of 16-bit serial data, two 8-bit shift resistors are connected in series.

IC22 and IC23 control the band selection, ON/OFF of preamplifier, ATT, power, TX mute function, etc. They are operated in Low level.

IC15 controls the Mode voltage, and IC16 controls filter, AGC, Break-in, PTT lock, and Noise blanker. The voltage of every mode (USB, LSB, AM, CW, CWU, CWL, FM, TUNE) turns ON Q41, Q42, Q43 and Q44 to supply 8V.

### m. LPF

HF supplied from PA final stage eliminates harmonics through LPF of filter unit. Input/Output of this filter is switched by the relay, and Input/Output of unused filter is short at the relay contact.

LPF control is used the BPF control voltage of the main unit.

Every LPF consists of Chebyshev filter, and double or more harmonics are attenuated about 40dB or more.

L0	~ 2.5MHz	BB0, BB1	1.8MHz band
L1	2.5MHz~4.0MHz	BB2	3.5MHz band
L2	4.0MHz~7.5MHz	BB3	7MHz band
L3	7.5MHz~14.5MHz	BB4, BB5	10, 14MHz band

L4	14.5MHz~21.5MHz	BB6	18, 21MHz band
L5	21.5MHz~30.0MHz	BB7	24, 28MHz band

The transmitting signal, whose spurious is eliminated by passing through LPF, is led to power detection circuit and supplied to HF antenna terminal passing through the selection relay.

### n. 50MHz Transmission/Reception Selector

50MHz band performs the transmission/reception selection by the diode of D508 and D509. It is supplied to antenna terminal of 50MHz through LPF.

Both D508 and D509 are turned OFF while receiving, the receiving signal from the antenna terminal is passed through LPF (L520, L521, C570~C574, L518, C565) and HPF (L516, C562~C564), then amplified in Q503.

Q501 and Q502 are turned ON while transmitting, and D508 and D509 are turned ON then the transmitting output is passed.

The antenna input of receiving circuit is short because D509 is turned ON. Also as the parallel resonant circuit consists of L518, D508, etc., the transmitting signal does not influenced.

### o. Power Detection Circuit

The each power detection circuit is equipped with HF band and 50MHz band.

The harmonics are sometimes generated depending on the using diode in the detection circuit. LPF makes the standing wave, so the circuit is located before the LPF in 50MHz band whose spurious specification is severe, and after LPF in HF band.

From now on the operation in HF band is shown, and in 50MHz band the operation is the same.

L534 is 10-turn bifilar of toroidal core (twisted pairs of AWG). Therefore the both sides are 20 turns with center tap.

Piercing the center hole of the core means the same with 1 turn. So the transformer is 1:20.

Therefore R508 is applied the voltage (forward wave voltage) according to the output voltage, and R509 is applied the voltage (reflected wave) according to the reflected power. The output power and reflection detect the power to control the power in the main unit.

### p. Dial Rotating Detection

The pulse generated by the rotation of the main dial is eliminated the chattering in IC1001: A, B. IC1001: A and B are the Schmitt triggers by the feedback from the output.

The rise and fall of each output is differentiated in IC1002:A, C, so the pulse number is doubled. Then it is 4 times the pulse number because of synthesizing in IC1001: C.

To find the rotation direction, it is detected in IC1002: B and IC1003 and fed to CPU. As S1002 generates 50 pulse at 1 rotation, what is input to CPU is 200 pulse/rotation, and 5kHz/rotation in 25Hz step.

The main dial rotates very fast and generates so many pulses. The pulse is divided in IC1004, and the pulse number is stored as the 6-bit binary digit by each dividing output. At a high speed rotation the frequency is forwarded by counting the pulse number stored in IC1004, then the process is finished, the pulse number



stored in IC1004 is reset by the output from CPU.

The dial rotation pulse is charged in D1016, R1022 and C1010, and the average voltage according to the speed is obtained. When the dial rotation speed is fast, the frequency step per pulse is four times that at normal speed.

### 3) Front Unit

#### a. Power Switch

When SW1001 is pressed, Q1001 is turned ON, then the contact of RL602 in PA unit is turned ON to supply the voltage of 13.8V to the front unit. Once the CPU starts operation, the output from PCONT of CPU turns Q1006 ON to hold ON the relay of RL602.

When SW1001 is kept pressing while the power is ON, the signal is detected in PSDET, and the Q1006 is turned OFF to cut OFF the power supply.

#### b. Power Supply

IC1007 is the regulated power supply of 5V which has the output for CPU reset. IC1006 is the regulated power supply of 8V which generates the required voltage for IF shift and volume control.

When the power supply is cut OFF, the output of regulated power supply of 8V is increased first, and it is detected in D1018 and IC1002:D, then sent to CPU. In CPU the data is stored in the EEPROM of IC1005 before the output of regulated power supply of 5V is decreased and the unit is reset. D1019 and C1002 are used to hold the output voltage of 5V by keeping the input voltage of 5V regulated power supply as long as possible.

#### c. Dimmer Circuit

The regulated power supply of about 10.5V consists of Q1003, Q1004 and Q1005. Q1003 supplies about 10.5V when the DIMM output from CPU is 5V.

In CPU unit, DIMM is the pulse output, and it switches ON/OFF of the output of about 10.5V.

At full lighting the output from CPU is fixed to 5V. In "LP4" mode the duty is 80% and in "LP 3" mode the duty is 60%. In this way the brightness is changed by the duty in Q1003.

Q1003 is supplied the current by turning ON/OFF. At the maximum the brightness is the lightest, and the duty is decreased according to the dimmer, then the power dissipation is decreased. The dimmer can be operated by the small transistor.

The maximum brightness is 10.5V, and it is set to under the regulation voltage (6.3V x 2) to prolong the life of the lamp. The rush current when the lamp is turned ON is in pulse mode to decrease the load on the lamp.

#### d. LCD

The indication such as frequency that is required the speed is performed by the CPU itself, and the other indications are performed by the LCD driver of IC1009. The LCD indication employs the frame frequency of about 128Hz, 1/2 DUTY and 1/2 bias.

#### e. Others

X1001 is the ceramic resonator of 8MHz selected not to enter the amateur band in the harmonics relations.

When the power is ON, the voltage is supplied from Y2 and Y3, to detect whether

it is connected to the outputs DB0~DB6 or not, then the destination is determined. The currents in Y0 and Y1, and between DB~DB6 are scanned to detect which switch on the front panel is pressed.

The both sides of RIT VR are applied 5V, and the location of VR is detected by the voltage of A/D input terminal.

In the Receiving frequency monitor Q1019 is turned ON by the MONI output from CPU, the squelch setting voltage programmed by turning the knob on the front panel is decreased forcedly. Then the squelch is open forcedly without any relation with VR position.

The output from the main unit (RTXC) lights the LED according to the change of the ALC voltage. The output cannot be supplied as it is, so it is changed to ON/OFF signal in Q1009.

Q1011 is the squelch output from the main unit, and it lights RX LED.

### 4) PLL Unit

#### Summary

The followings are performed in PLL unit:

- The generation of carrier signal
- The generation of the first and second local oscillating signal
- The generation of sidetone CTCSS
- Adding the FM modulation
- Making the power supply of 5V

#### Details

(1) There are 3 kinds of power supply as follows:

- The voltage of 13V passed through the switch
- The voltage of 8V made in the MAIN unit
- The voltage of 5V made in the PLL unit

Power supply depending on the MODE comes from the main unit.

- (2) First the reference signal of 30MHz is generated in X701 and Q701 according to the constant of TC701 and L702.
- (3) Secondly the signal of 9.420MHz +/- 1.5kHz is generated by the voltage of D706 in X702, Q721 and Q722.
- (4) Thirdly the signal of 9.875MHz +/- 1.5kHz is generated according to the constant of TC702-TC704, C807, C809, C810, C811 and C812 in Q725 and Q724.
- (5) The frequency of 9.875MHz is changed according to the MODE, transmission/reception.

[Transmission/Reception of LSB]

CN701 Pin21 (LSB) is applied the voltage of 8V and the signal is passed through D714, then results in the frequency of 9.8735MHz according to the constant of TC702 and C812. Also (LSB) 8V is passed through D718, and the voltage is applied to Q723 to emit the carrier signal.

[Transmission/Reception of USB]

CN701 Pin26 (USB) is applied the voltage of 8V and the signal is passed through D711, then results in the frequency of 9.8765MHz according to the constant of TC704 and C807. Also (LSB) 8V is passed through D717, and the voltage is

applied to Q723 to emit the carrier signal.

[Reception of AM/FM/TUNE]

CN701 Pin20 (FM) or CN701 Pin22 (AT) is added the voltage of 8V and in the FM mode the signal is passed through D708, then results in the frequency of 9.875MHz according to the constant of TC703 and C811. Q723 has no voltage, and carrier signal is never emitted.

[Transmission of AM/TUNE]

CN701 Pin22(AT) is applied 8V and results in the frequency of 9.875MHz according to the constant of TC703, C811.

The voltage of 8V from CN701 Pin23 (T8V) is passed through D718 to add the voltage to Q723, then the carrier signal is emitted.

[Transmission of FM]

CN701 Pin20 (FM) and CN701 Pin23 (T8V) are added the voltage of 8V, the Q729 and Q733 are turned ON. 8V voltage of CN701 Pin20 (FM) is passed through D708, Q733 and D714, then results in the frequency of 9.8735MHz according to the constant of TC702 and C812. Here FM is passed through AT and R814 to turn ON C811, however, as Q733 is also turned ON, Q727 is turned ON and C811 is shorted.

The voltage of 8V from CN701 Pin23 (T8V) is passed through D718, and led to Q723 to emit the carrier signal.

The voltage of 8V from Q733 turns ON the analogue switch of IC715.

The modulation signal is passed through R798, IC715, R796 and C801, and it is FM-modulated in VCO2.

[The Transmission of CWU/CWL]

CN701 Pin24 (CWU) or CN701 Pin25 (CWL) is supplied the voltage of 8V, then it is passed through D716, D732, Q716 (because Q729 is ON) and R814, then results in the frequency of 9.875MHz according to the constant of TC703 and C811.

Although here CWU tries to turn C810 ON or CWL tries to turn C809 ON, it can not be done through D715 because Q729 is also turned ON.

[The Reception of CWU]

CN701 Pin24 (CWU) is supplied the voltage of 8V, passed through D712, then resulting in the frequency of 9.8758MHz of frequency according to the constant of TC703 and C810. Also the voltage of 8V from CN701 Pin24 (CWL) is passed through D716 and D717 to the Q723, then the carrier signal is emitted.

[The Reception of CWL]

CN701 Pin25 (CWU) is supplied the voltage of 8V, passed through D712, then resulting in the frequency of 9.8742MHz of frequency according to the constant of TC703 and C809. Also the voltage of 8V from CN701 Pin25 (CWL) is passed through D716 and D717 to the Q723, then the carrier signal is emitted.

(6) The frequency of 9.42MHz can be changed only while receiving by the IF shift volume on the front panel.

The voltage supplied to CN701 Pin14 (SHV) is changed by the IF shift volume, and

the capacitance of D706 is also changed, then 9.42MHz is changed. The center frequency of the IF shift volume is determined by VR702.

While transmitting Q715 is turned ON by T8V to eliminate the influence by SHV and VR 701, then the frequency is decided only by VR701.

In USB CN701 Pin26 (USB) and CN701 Pin15 (TONS) are supplied the voltage of 8V. As in UT mode TONS becomes the sink, Q735 is turned OFF and USB is supplied 0V, then Q730 is turned ON and a terminal of R767 is connected to the ground to decrease the voltage of D706, beside the frequency of 9.42MHz is decreased about 300Hz less while receiving and about 100Hz less while transmitting than the value in USB mode.

In the same manner, in LSB mode the voltages of CN701 Pin21 (LSB) and CN701 Pin15 (TONS) are 8V. As in LT mode TONS becomes the sink, Q735 is turned OFF and D729 is supplied the voltage by R767. Then voltage of D706 is increased. Beside the frequency of 9.42Hz is increased about 300Hz more while receiving and about 100Hz more while transmitting than the value in LSB mode.

(7) The Emission of 455kHz Carrier Signal

The above-mentioned 9.875MHz signal is input to Mixer IC712 Pin6, and 9.42MHz signal is input to IC712 Pin8. The difference frequency of 455kHz is output from IC712 Pin3 and sent to the MAIN unit from J701 after amplified in Q723. The Output level is approximately -5dB.

(Frequency Relations depending on the Mode)

USB(TX RX)		9.8765MHz - 9.42MHz (**)	= 456.5kHz (**)
LSB(TX RX)	FM(TX)	9.8735MHz - 9.42MHz (**)	= 453.5kHz (**)
CWU CWL AM TUNE (TX)		9.8750MHz - 9.42MHz	= 455.0kHz (*)
CWU(RX)		9.8758MHz - 9.42MHz (*)	= 453.5kHz (*)
CWL(RX)		9.8742MHz - 9.42MHz (*)	= 453.5kHz (*)
UT(RX)		9.8765MHz - 9.4197MHz (*)	= 456.8kHz (*)
LT(RX)		9.8735MHz - 9.4203MHz (*)	= 453.2kHz (*)
UT(TX)		9.8765MHz - 9.4199MHz	= 456.6kHz
LT(TX)		9.8735MHz - 9.4201MHz	= 453.4kHz

AM FM (RX) does not output

(\*\*): While receiving IF Shift Operation (+/- 1.5kHz)

(\*): IF Shift Operation (+/- 1.5kHz)

(8) The Second Local Oscillating Signal

In VCO2 unit, after the frequency of 71.295MHz is oscillated in Q941 and amplified in Q949, Q944 and Q945, the signal of approximately 3dB is supplied to MAIN unit through J702 as the second local oscillating signal.

The signal for PLL loop is supplied from Q942 to PLL unit.

The signal of 71.295MHz is fed to Mixer IC711 Pin7 and the signal of 9.42MHz is fed to Pin3, so that the reference frequency of 61.875MHz output from Pin6 only is picked up by Q711, L712 and L711, and fed to PLL IC707, then locked at 61.875MHz.

Therefore, by rotating the IF shift volume, 9.42MHz, and also 71.295MHz are changed.

The frequency of 30MHz is fed to IC707 through Pin1, and it is divided to get the following frequency as the reference frequency, and also the frequency of

61.875MHz is divided to get the reference frequency, then these two frequencies are compared.

The reference frequency changes according to the CW sidetone frequency.

When the sidetone frequency is 650Hz, the reference frequency is 64.655kHz.

When the sidetone frequency is 750Hz, the reference frequency is 75.000kHz.

When the sidetone frequency is 850Hz, the reference frequency is 85.227kHz.

#### (9) The First Local Oscillating Signal

In the HF mode, the frequency oscillated in VCO3 is amplified in Q710 and Q714, and passed through the switching diode D725 and D726, then band-pass filter and RL701. The signal of approximately 3dB is led to the MAIN unit from J703.

3 VCO's are built in VCO3, and it is oscillated under following frequency conditions:

150kHz~under 10.5MHz:

The VCO is oscillated within 71.90~82.25MHz by D961, TC961 and Q961.

10.5kHz~under 21.5MHz:

The VCO is oscillated within 82.25~93.25MHz by D963, TC962 and Q963.

21.5kHz~under 30.0MHz:

The VCO is oscillated within 93.25~101.75MHz by D965, TC963 and Q965.

These 3 VCO's are selected by the serial data of DAT2, CK2 and ENB from CPU. 8 signals from IC716 are reduced up to 3 signals, then VCO is selected by the switches of VCO3, Q962, Q964 and Q966.

When the frequency is 50MHz, in VCO3 the oscillated frequency within 76.75~80.75MHz by D961, TC961 and Q961 are synthesized with the frequency of 45MHz by the DBM (Double Balanced Mixer) in L729, L730 and D730, then the frequency within 121.75~125.75MHz is generated. It is passed through RL701 by the band-pass filters of L732, L733, L734 and L735 and Amplifier of Q731 and Q716, then the signal of approximately 3dB is output to J703.

The frequency of 45MHz is generated as follows: The reference signal of 30MHz is amplified in Q719 and fed to IC701 Pin3, then one half of the signal is supplied from Pin5. 3 times frequency of the signal only is passed through the filter L720, L721 and L722, and fed to the center tap of L729, then led to DBM.

The frequency loop of VCO3 is locked as follows: VCO3 oscillating frequency is passed through Q712 and input to the mixer IC709 Pin6, also the signal of 70.65~70.75MHz (25Hz step) is fed to IC709 Pin8. Then the signal of 1.1~31.1MHz passed through the amplifier Q713 and led to PLL IC702 Pin8 as the difference signal.

This frequency is locked by the following procedure.

1.1MHz is added to the digit number of 100kHz or more of the operation frequency, and divided to obtain 100kHz. Then the frequency is locked after comparing with the reference frequency 100kHz. See the examples as shown below.

Operation Frequency: 1MHz

→ PLL The frequency fed to IC702 Pin8: 2.1MHz

Operation Frequency: 29MHz

→ PLL The frequency fed to IC702 Pin8: 30.1MHz

Therefore, as the reference frequency of IC702, the reference frequency of 30MHz is divided up to 100kHz inside the unit.

In IC702, the operation frequency of 100kHz or more only is controlled.

In 50MHz band, CN701 Pin1 (50M) is sink, Q732 collector is supplied the voltage of 8V. The power supply of Q731, Q716 is turned ON. Q709 and D730 are turned ON. Q709, RL701, D724 and D724 are turned ON, then D730 is ON and Q724 is OFF.

The deviation while transmitting is 5kHz/DEV, and 2.5kHz/DEV while HF/FM transmitting.

In the HF mode, Q717 is ON, and D725 and D726 are turned ON, then D735 is ON. IC710 Pin4 is supplied about 0.7V so that the operation of IC710 is stopped.

When the unlock signal is emitted from every Pin7 in PLL IC IC702, IC703 and IC707, the voltage of 8V is supplied from the collector in Q728, and Q718 is turned ON so that Q714 is turned OFF, then the level of J703 is decreased about 30dB or more.

#### {10} 25Hz Step 70.65~70.75MHz

In VCO1 Unit, to generate 25Hz step of the first local oscillating, Q931 is used to oscillate the frequency of 155MHz~175MHz, the signal is passed through Q932 and divided by 20 in IC704, and supplied through Q933. Then the signal is divided by 10 in IC705, and the frequency of 775~875kHz (25Hz step) is fed to the mixer IC701. Therefore, the operation frequency of 100kHz digit or below can be operated in 25Hz step.

Also the frequency is input to PLL unit IC703 Pin8 through Q931 for the PLL loop. PLL IC divides the frequency of 155.000~174.995MHz to get 5kHz, and it is compared with the reference frequency of 5kHz to make the loop.

indication of the operation frequency of 100kHz digit or below	Oscillating frequency
.0000(00)	155.000MHz
.5000(00)	165.000MHz
.9999(75)	174.995MHz

\*The number in ( ) is the frequency of no indication.

The reference frequency of 30MHz is divided to get 5kHz (25Hz x 200), and used as the reference frequency in IC703. Because the signal of 9.875MHz is input to IC701 Pin8, the sum of the frequencies, 10.65~10.75MHz is supplied from IC703 Pin2, and passed through the ceramic filter of 10.7MHz, then fed to IC706 Pin6.

As the double harmonics of reference frequency of 30MHz are generated in Q708, L710 and L709, and they are fed to IC706 Pin8. The sum of the frequency of 70.65~70.75MHz is supplied from IC703 Pin3, passed through the band-pass filter of L706, L707 and L708, and fed to IC709 Pin8. Then the signal is included in a part of the loop of the first local oscillating signal.

(11) CTCSS for only FM transmission

In Tone unit, T type controls the frequency with the DIP Switch SW901 Pin3 - 8, then it is oscillated between 67~251Hz, amplified in Q901 and passed through CN704-1, then led to the MAIN unit from CN701 Pin16.

In this circuit, ON operation is performed when TONS is the sink and IC901 Pin4 is 0V, and FM is supplied 8V and tone unit power supply is ON.

The tone level is controlled with the DIP switch SW901 Pin1 and Pin2 to adjust the level.

(12) FM TX deviation

Default is  $\pm 2.5\text{kHz}$  deviation on 29MHz and  $\pm 5\text{kHz}$  deviation on 51MHz.

a) Short-circuiting collector and emitter of Q734 will make both bands  $\pm 2.5\text{kHz}$ .

b) Short-circuiting the base and emitter of Q734 (and collector and emitter open) will make both bands  $\pm 5\text{kHz}$ .

Short-circuiting both(a) and (b) will result in the same effect as (a).

## 5) Terminal function of CPU

No.	Use1	Use2	Use3	Pin Name	Remarks	IO	Description	L	H
2			AVSS	GND		-			
3				GND		-			
4			X2	XTAL_LOSC		-			
5			X1	XTAL		-			
6			VSS	GND		-			
7			OSC1	XTAL		-			
8			OSC2	XTAL		-			
9			/RES	/RST		I			
10			MDO	SV7		I			
11	P20	IRQ4	ADTRG	DCX	DIAL CLOCK	I	Main dial rotation detection and pulse number	Rise edge detection	
12	P21		UD	PCONT	POWER ON	O	Power control output	Power OFF	Power ON
13	P22			PSDET	POWER DET	I	Condition detection when power switch is turned ON.	During power OFF	During power ON
14	P23			TKEY	TUNE KEY	I	Detection of working external antenna tuner	At work	Waiting
15	P24			UNLK	PULL UNLOCK	I	PLL unlock detection	Unlock	Lock
16	P25			MCK	EEPROM CK	O	Clock for data transmission/reception to EEPROM		
17	P26			MDAT	EEPROM DATA	VO	Data Transmission/Reception to EEPROM		
18	P27			EXTIN	EXT IN	I	External EEPROM transmission acceptance	EEPROM	Acceptance
19	P30		SCK1	CK1	SERIAL1 CK	O	HPL, LPL data transmission clock		
20	P31		SI1	DAT1	SERIAL1 DATA	O	HPL, LPL data transmission		
21	P32		SO1	ENH	HPLL ENABLE	O	HPL data transmission enable		Enable
22	P33		SCK2	ENL	LPLL ENABLE	O	LPL data transmission enable		Enable
23	P34		SI2	CK2	SERIAL2 CK	O	MODE, BPF, etc. transmission clock		
24	P35		SO2	DAT2	SERIAL2 DATA	O	MODE, BPF, etc. data transmission		
25	P36		STRB	ENA	SERIAL SELECT	O	MODE, BPF, etc. data enable selection		Enable 1
26	P37		CS	ENB	SERIAL SELECT	O	MODE, BPF, etc. data enable selection		Enable 2
27			VSS	GND		-			
28			V3			-			
29			V2			-			
30			V1			-			
31			Vcc	5V		-			
32	PA3	COM4		COM4		O	LCD COMMON		
33	PA2	COM3		COM4		O	LCD COMMON		
34	PA1	COM2		COM3		O	LCD COMMON		
35	PA0	COM1		COM3		O	LCD COMMON		
36	P50	SEG1	WKP0	DB0		I	SW, initial setting detection		Detection
37	P51	SEG2	WKP1	DB1		I	SW, initial setting detection		Detection
38	P52	SEG3	WKP2	DB2		I	SW, initial setting detection		Detection
39	P53	SEG4	WKP3	DB3		I	SW, initial setting detection		Detection
40	P54	SEG5	WKP4	DB4		I	SW, initial setting detection		Detection
41	P55	SEG6	WKP5	DB5		I	SW, initial setting detection		Detection
42	P56	SEG7	WKP6	DB6		I	SW, initial setting detection		Detection
43	P57	SEG8	WKP7			O			Detection
44	P60	SEG9		Y0		O	Panel SW for ON detection		At detecting
45	P61	SEG10		Y1		O	Panel SW for ON detection		At detecting
46	P62	SEG11		Y2		O	Output for initial condition setting detection		
47	P63	SEG12		Y3		O	Output for initial condition setting detection		
48	P64	SEG13		GND		O			
49	P65	SEG14		LCDEN		O	LCD driver enable		
50	P66	SEG15		LCDCX		O	LCD driver clock		
51	P67	SEG16		LCDDATA		O	LCD driver data		

# SEMICONDUCTOR DATA

## 1) S7116A (XA0052) Tone Generator

### Block Diagram

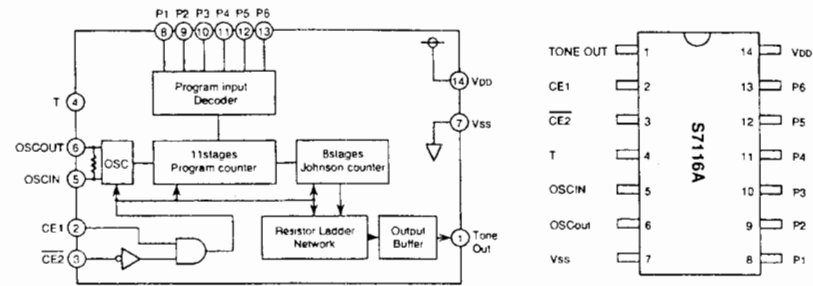

Parameter	Symbol	Condition	Min	Typ	Max	Unit
Supply voltage	VDD		3.0	-	10	V
Supply current	I <sub>DD</sub>	VDD=5.0V, CE1=VDD, CE2=VSS, CG=CD=10pF	-	0.4	1.0	mA
Stand by current	I <sub>DD</sub> S	VDD=5.0V, input: open, RL=50kΩ	-	20	60	μA
Tone output level	VOT	VDD=5.0V, RL=50kΩ	240	340	440	mV rms

Freq.	P1	P2	P3	P4	P5	P6	Freq.	P1	P2	P3	P4	P5	P6
67.0	1						186.2		1	1	1	1	
71.9		1					192.8	1	1	1	1	1	
74.4	1	1					203.5						1
77.0			1				210.7	1					1
79.7	1		1				218.1		1				1
82.5		1	1				225.7	1	1				1
85.4	1	1	1				233.6			1			1
88.5				1			241.8	1		1			1
91.5	1			1			250.3		1	1			1
94.8		1		1			500	1	1	1			1
97.4	1	1					600				1		1
100.0			1	1			700	1		1			1
103.5	1		1	1			800		1		1		1
107.2			1	1	1		900	1	1		1		1
110.9	1	1	1	1			1000			1	1		1
114.8					1		1600	1			1	1	
118.8	1				1		1700		1	1	1		1
123.0		1			1		1750	1	1	1	1		1
127.3	1	1			1		1800					1	1
131.8			1		1		1300	1				1	1
136.5	1		1		1		2000		1			1	1
141.3			1	1	1		2200	1	1			1	1
146.2	1	1	1		1		2975			1		1	1
151.4				1	1		2550	1		1		1	1
156.7	1			1	1		2295		1	1	1		1
162.2		1		1	1		2125	1	1	1		1	1
167.9	1	1		1	1		1275				1	1	1
173.8			1	1	1		1445	1			1	1	1
179.9	1		1	1	1								

No.	Use1	Use2	Use3	Pin Name	Remarks	I/O	Description	L	H
52	P70	SEG17		SEG17		O	Output to LCD Segment		
53	P71	SEG18		SEG18		O	Output to LCD Segment		
54	P72	SEG19		SEG19		O	Output to LCD Segment		
55	P73	SEG20		SEG20		O	Output to LCD Segment		
56	P74	SEG21		SEG21		O	Output to LCD Segment		
57	P75	SEG22		SEG22		O	Output to LCD Segment		
58	P76	SEG23		SEG23		O	Output to LCD Segment		
59	P77	SEG24		SEG24		O	Output to LCD Segment		
60	P80	SEG25		SEG25		O	Output to LCD Segment		
61	P81	SEG26		SEG26		O	Output to LCD Segment		
62	P82	SEG27		SEG27		O	Output to LCD Segment		
63	P83	SEG28		SEG28		O	Output to LCD Segment		
64	P84	SEG29		SEG29		O	Output to LCD Segment		
65	P85	SEG30		SEG30		O	Output to LCD Segment		
66	P86	SEG31		SEG31		O	Output to LCD Segment		
67	P87	SEG32		SEG32		O	Output to LCD Segment		
68	P90	SEG33		SEG33		O	Output to LCD Segment		
69	P91	SEG34		SEG34		O	Output to LCD Segment		
70	P92	SEG35		SEG35		O	Output to LCD Segment		
71	P93	SEG36		SEG36		O	Output to LCD Segment		
72	P94	SEG37	M	SEG37		O	Output to LCD Segment		
73	P95	SEG38	DO	SEG38		O	Output to LCD Segment		
74	P96	SEG39	CL2	SEG39		O	Output to LCD Segment		
75	P97	SEG40	CL1	SEG40		O	Output to LCD Segment		
76		Vcc	5V						
77	P10		TMOW	MONI		O	Open the squelch forcibly (monitor)		Squelch open forcibly
78	P11		TMOFL	LIT		O	The command to put out the light forcibly and flashing to LCD driver	Put out the light forcibly	During lighting
79	P12		TMOFH	BEEP		O	Beep sound output	Pulse output	
80	P13		TMIG	SQS		I	Squelch open/close condition detection	Squelch close	Squelch open
81	P14		PWM	DIMM	DIMMER	O	LCD dimmer control	Duty control of pulse output	
82	P15	IRQ1	TMIB	TXS		I	Transmission condition detection	Transmission	Reception
83	P16	IRQ2	TMIC	SUBA		I	MF dial rotation detection		
84	P17	IRQ3	TMIF	SUBB		I	MF dial rotation detection		
85	P40	SCR3	DRST	COUNT RESET		O	Dial pulse count reset	During counting	Reset
86	P41		RXD	GND		I			
87	P42		TXD	GND		I			
88	P43	IRQ0	POWON	POWER DOWN		I	Power OFF detection	Power OFF	Power OK
89			AVcc	5V					
90	P80	AN0		DO1		I	Dial clock 1/2		
91	P81	AN1		DO2		I	Dial clock 1/4		
92	P82	AN2		DO3		I	Dial clock 1/8		
93	P83	AN3		DO4		I	Dial clock 1/16		
94	P84	AN4		DO5		I	Dial clock 1/32		
95	P85	AN5		DO6		I	Dial clock 1/64		
96	P86	AN6		DO		I	Dial up rotation		Up
97	P87	AN7		/DO		I	Dial down rotation		Down
98	PC0	AN8		DSDET		A/D	Dial speed detection	The voltage according to the speed of rotation.	
99	PC1	AN9		RIT		A/D	RIT VR position detection	0-5V	
100	PC2	AN10		UID		A/D	Micro UP/DOWN detection	2-3V down	0-2V up
1	PC3	AN11		SRF		A/D	S & RF Meter voltage input	0-5V	

**2) MC3357 (XA0063)**  
Low Power FM IF

Vcc=6V  
F=10.7MHz  
Icc 3mA  
Limit 5μV -3dB  
Vo 350mV Dev=+/-3KHz

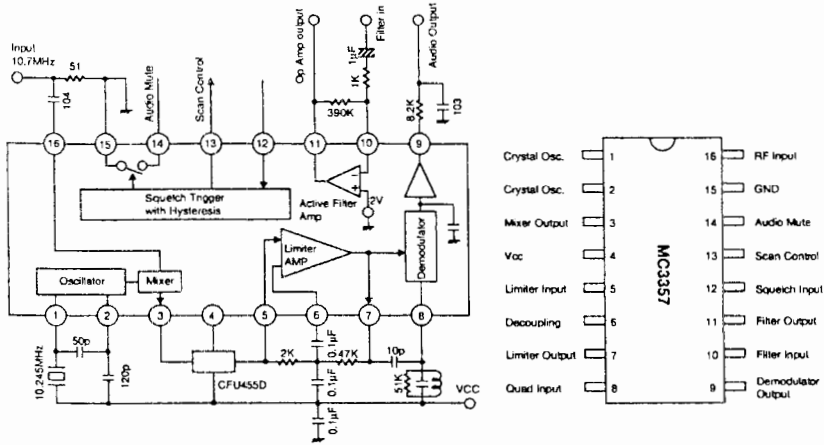

**3) M5218FP (XA0068)**  
Dual Low Noise  
Operational Amplifiers

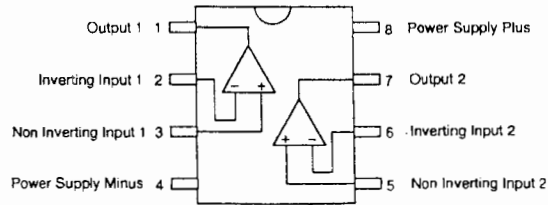

**4) NJM78L08UA (XA0075)**  
8V Voltage Regulator

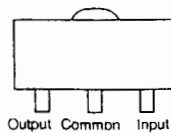

**5) μPC1241H (XA0079)**  
Audio Power Amplifiers

Test Circuit

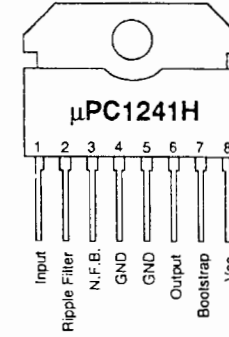
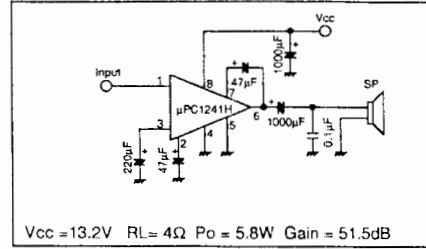

**6) MC7808CT (XA0082)**  
8V Voltage Regulator

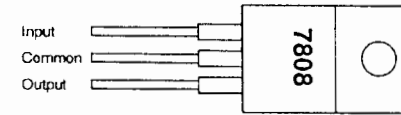

**7) μPD6345GS (XA0114)**  
8bit Serial in Parallel Out Driver

No.	Pin Name	Description
1	GND	GND terminal
2	EN	Enable terminal
3	LAT	Latch terminal
4	SO	Serial data output terminal
5-12	$\overline{O8-O1}$	Data output terminal
13	SIN	Serial data input terminal
14	SCX	Serial clock input terminal
15	RES	Reset input terminal
16	Vcc	Power supply terminal

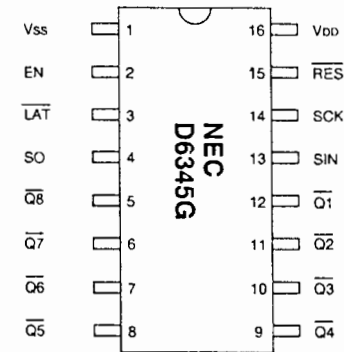

**8) TC4S66F (XA0115)**  
Bilateral Switch

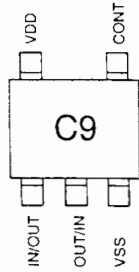
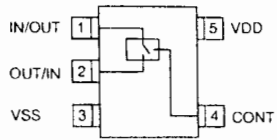

**9) NJM2904M (XA0224)**  
Dual Operational Amplifiers

**Block Diagram**

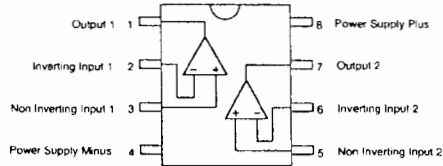
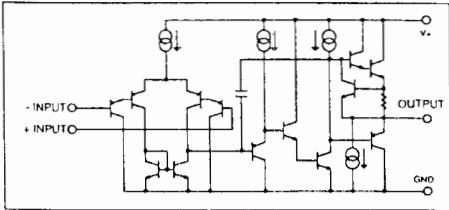

**10) BU4052BF (XA0236)**  
Analog Multiplexer/Demultiplexer

**Logic Diagram**

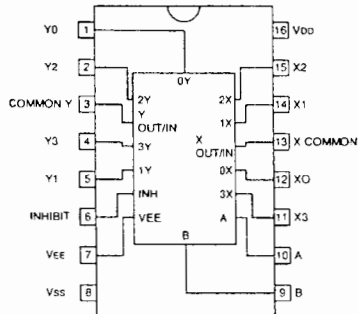
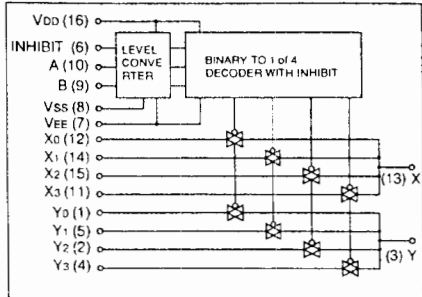

**Truth Table**

INHIBIT	A	B	ON SWITCH
L	L	L	X0 Y0
L	H	L	X1 Y1
L	L	H	X2 Y2
L	H	H	X3 Y3
H	X	X	NONE

X: Don't Care

**11) BU4094BF (XA0246)**  
8-Stage Shift Register

**Truth Table**

Clock	Output enable	Strobe	Data	Parallel outputs		Serial outputs	
				Q1	Qn	Qs	Q's
	L	X	X	Z	Z	Q7	No Chg.
	L	X	X	Z	Z	No Chg.	Qs
	H	L	X	No Chg.	No Chg.	Q7	No Chg.
	H	H	L	L	Qn-1	Q7	No Chg.
	H	H	H	H	Qn-1	Q7	No Chg.
	H	X	X	No Chg.	No Chg.	No Chg.	Qs

Z=High Impedance  
X=Don't Care

**Block Diagram**

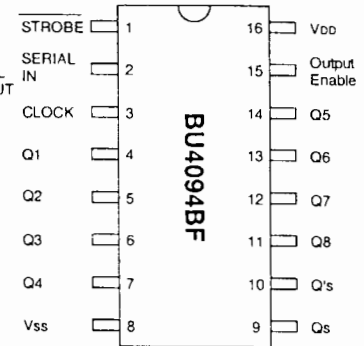
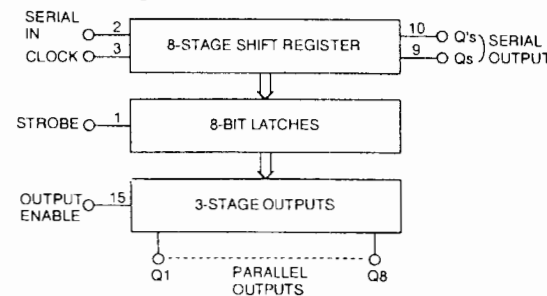

**12) MC12019D (XA0292)**  
Two-Modulus Prescaler

**Block Diagram**

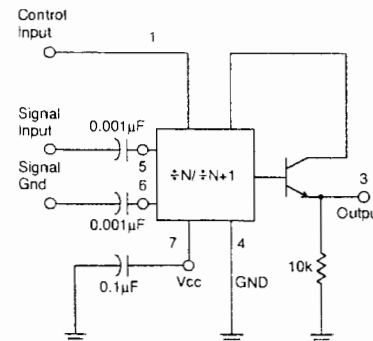

Characteristics	Symbol	Min.	Typ	Max	Unit
Toggle frequency (Sine wave input)	fmax fmin	225	-	- 20	MHz
Supply current	Icc	-	-	7.5	mA
Control input High (1/20)	VIH	2.0	-	-	V
Control input Low (1/21)	VIL	-	-	0.8	V
Output voltage swing	Vout	600	-	1200	mVpp
Input voltage sensitivity	Vin	200	-	800	mVpp
PLL response time	tPLL	-	-	tout-70	ns

**13) MC74HC4040F (XA0293)**  
12-Stage Binary Ripple Counter

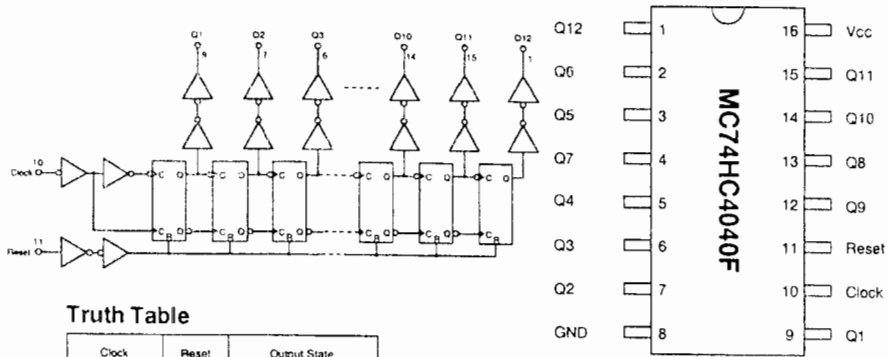

**Truth Table**

Clock	Reset	Output State
	L	No Change
	L	Advance to next stage
X	H	All outputs are low

**15) MC14024BF (XA0295)**  
7-Stage Binary Counter

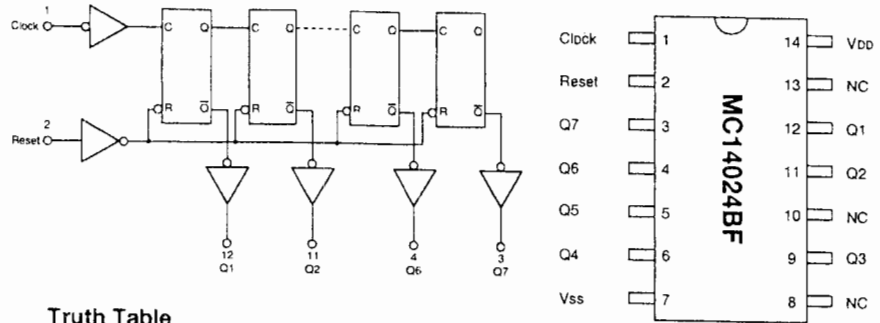

**Truth Table**

Clock	Clear	Output State
Don't care	H	All Output="L"
	L	No Change
	L	Advance to next stage

**14) MC74HC390F (XA0294)**  
Dual 4-Stage Binary Ripple Counter 1/2 and 1/5 Sections

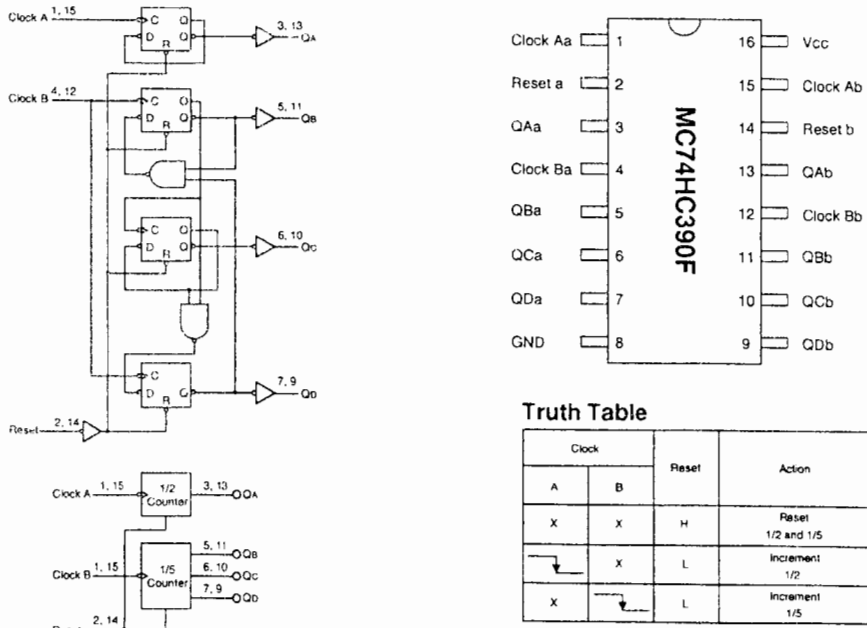

**Truth Table**

Clock		Reset	Action
A	B		
X	X	H	Reset 1/2 and 1/5
	X	L	Increment 1/2
X		L	Increment 1/5

**16) MC14071BF (XA0296)**  
Quad 2-Input OR Gate

**Truth Table**

Input		Output
A	B	X
L	L	L
L	H	H
H	L	H
H	H	H

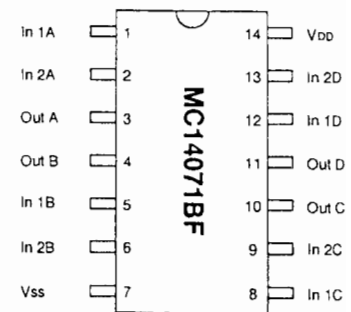
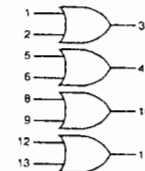



17) MB87086A (XA0297)  
PLL Frequency Synthesizer

No.	Pin Name	I/O	Description
1	OSCIN	I	Crystal connection terminal
2	OSCOU	O	Crystal connection terminal
3	Iv	O	Phase comparator input monitor terminal Comparator divider output terminal
4	VDD	-	Power supply
5	Dop	O	Passive LPF connection terminal I<-Iv: Drive mode, Dop="H" I<-Iv: High impedance I<-Iv: Sink mode, Dop="L"
6	VSS	-	GND terminal
7	LD	O	Phase detector output terminal Lock="H", Unlock=negative pulse
8	fin	I	Comparator divider input terminal
9	Clock	I	Serial clock input terminal
10	Data	I	Serial data input terminal
11	LE	I	Load enable input terminal
12	DoA	O	Active LPF connection terminal I<-Iv: Drive mode, DoA="L" I<-Iv: High impedance I<-Iv: Sink mode, DoA="H"
13	fr	O	Phase comparator input monitor terminal Reference divider output terminal
14	NC	-	No connection
15	eV	O	Differential LPF connection terminal I<-Iv: eV="H", eR="L" I<-Iv: eV="H", eR="H" I<-Iv: eV="L", eR="H"
16	eR	O	

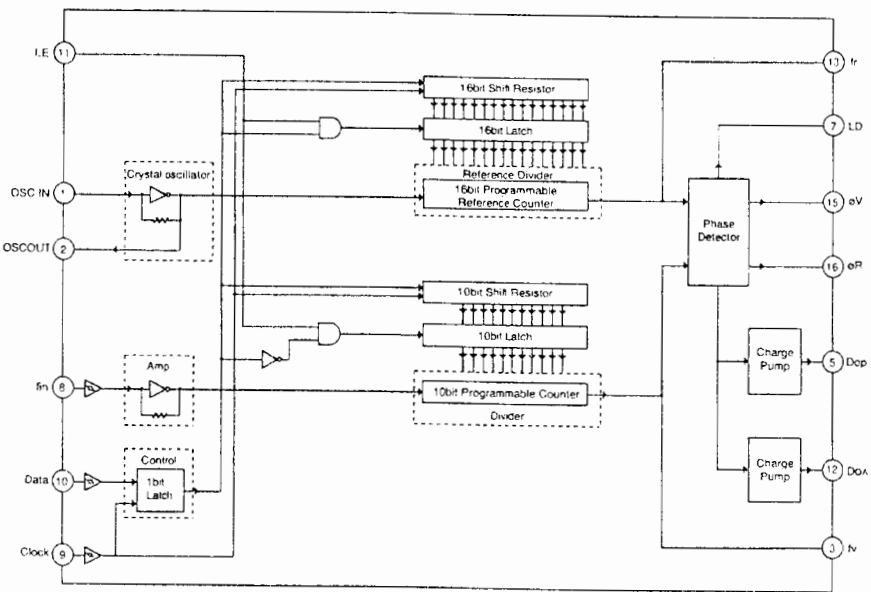
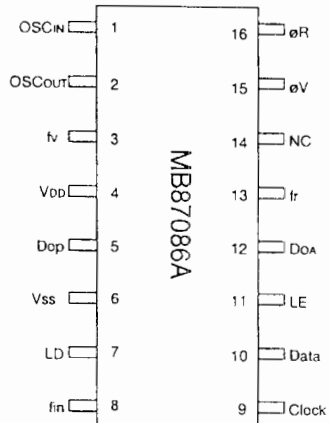

18) MB87014A (XA0298)  
PLL Frequency Synthesizer

No.	Pin Name	I/O	Description
1	OSCIN	I	Crystal connection terminal
2	OSCOU	O	Crystal connection terminal
3	Iv	O	Phase comparator input monitor terminal Comparator divider output terminal
4	VDD	-	Power supply
5	Dop	O	Passive LPF connection terminal I<-Iv: Drive mode, Dop="H" I<-Iv: High impedance I<-Iv: Sink mode, Dop="L"
6	VSS	-	GND terminal
7	LD	O	Phase detector output terminal Lock="H", Unlock=negative pulse
8	fin	I	Prescaler input terminal
9	Clock	I	Serial clock input terminal
10	Data	I	Serial data input terminal
11	LE	I	Load enable input terminal
12	DoA	O	Active LPF connection terminal I<-Iv: Sink mode, DoA="L" I<-Iv: High impedance I<-Iv: Drive mode, DoA="H"
13	fr	O	Phase comparator input monitor terminal Reference divider output terminal
14	NC	-	No connection
15	eV	O	Differential LPF connection terminal I<-Iv: eV="H", eR="L" I<-Iv: eV="H", eR="H" I<-Iv: eV="L", eR="H"
16	eR	O	

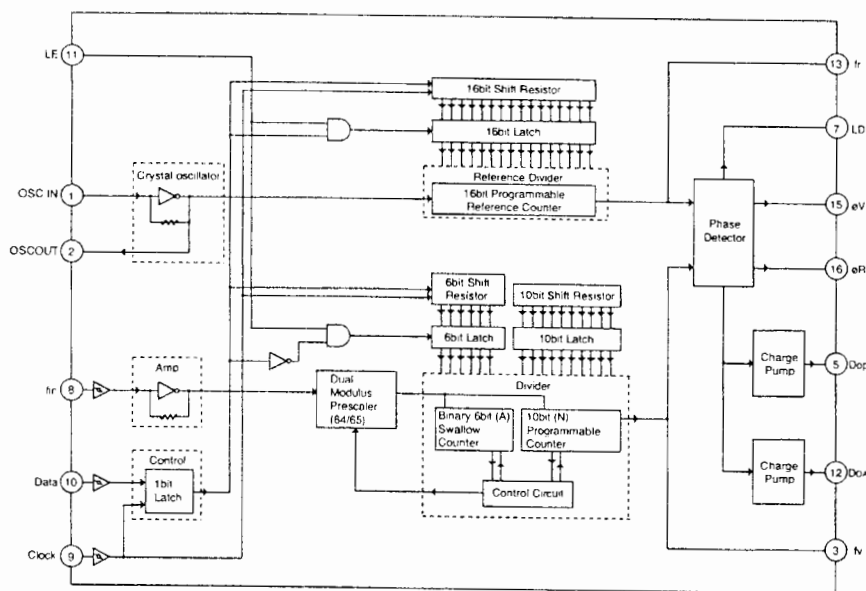
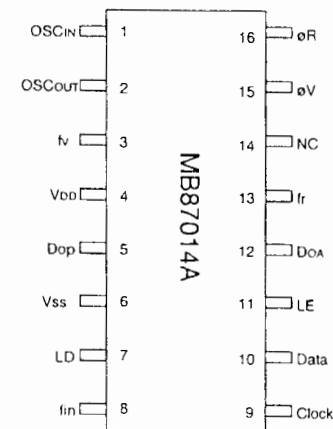

19) MC4001BF (XA0299)  
Quad 2-Input NOR Gate

Truth Table

Input		Output
A	B	X
L	L	H
L	H	L
H	L	L
H	H	L

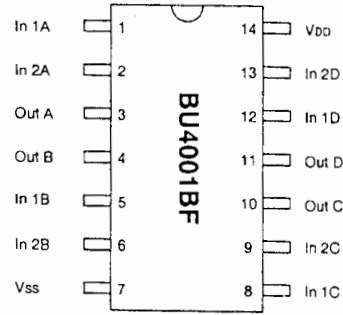
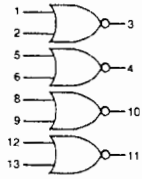

20) AN612 (XA0300)  
Balanced Modulator Circuit

Parameter	Symbol	Condition	Ratings	Unit
Max. supply voltage	Vcc		14.4	V
Supply current	Icc		15	mA
Power dissipation	PD		220	mW
Total current	I <sub>tot</sub>	V6=12.0V	9.5	mA
Zener voltage	V5-4		6.15	V
Signal input terminal voltage	V1-4		3.1	V
Carrier input terminal voltage	V3-4		3.4	V
Output terminal voltage	V7-4		8.6	V
Output voltage (BM AC)	V <sub>o</sub> (BM)	V6=9.0V	-3	dBm
Carrier suppression	SC		50	dB

Test Circuit

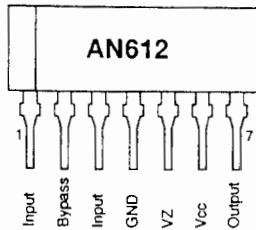
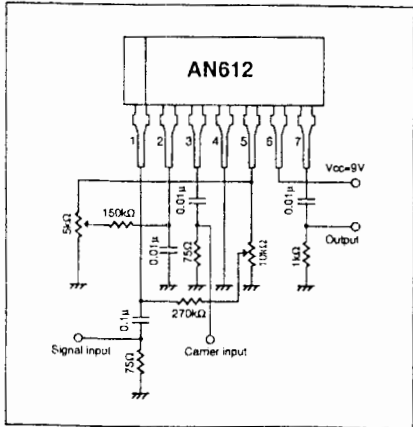

21) M5222FP (XA0385)  
Low Voltage Dual VCA

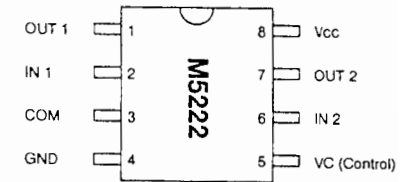
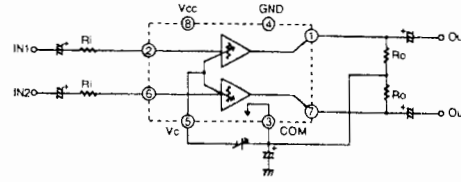

Parameter	Symbol	Condition	Vcc	Min	Typ	Max	Unit
Supply current	Icc	V <sub>i</sub> =0, V <sub>c</sub> =0	3V	2.5	3.6	5.5	mA
Max. input voltage	V <sub>iM1</sub>	f=1kHz, V <sub>c</sub> =0, THD=1%, R <sub>i</sub> =10kΩ, R <sub>O</sub> =20kΩ	3V	0.7	1.0	-	V <sub>rms</sub>
	V <sub>iM2</sub>	f=1kHz, V <sub>c</sub> =0, THD=1%, R <sub>i</sub> =50kΩ, R <sub>O</sub> =100kΩ	9V	2.3	3.4	-	V <sub>rms</sub>
Max. attenuation level	ATT <sub>M</sub>	V <sub>c</sub> =-270mV, R <sub>i</sub> =10kΩ, R <sub>O</sub> =20kΩ	3V	80	90	-	dB
Noise output voltage	V <sub>NO1</sub>	V <sub>c</sub> =0 (ATT=-1.4dB) R <sub>i</sub> =10kΩ, R <sub>O</sub> =20kΩ, BW=20Hz-20kHz	3V	-	30	60	μV <sub>rms</sub>
Noise output voltage	V <sub>NO2</sub>	V <sub>c</sub> =-40dB R <sub>i</sub> =10kΩ, R <sub>O</sub> =20kΩ, BW=20Hz-20kHz	3V	-	5	-	μV <sub>rms</sub>

22) LC75821W (XA0303)  
LCD Driver

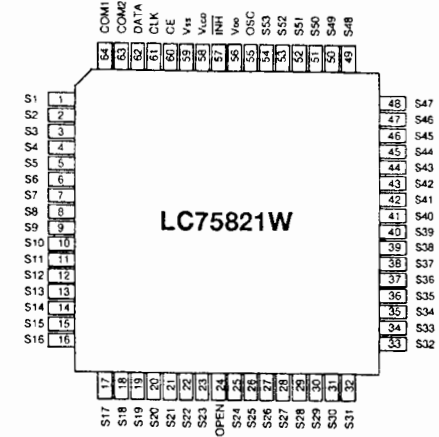
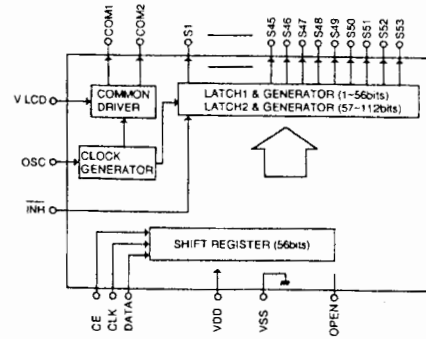

Pin Name	Description
S1-S53	Segment output terminal
COM1, 2	Common output terminal
V LCD	LCD Bias voltage setting terminal
OSC	Oscillator terminal
CE, CLK, DATA	Serial data transmission terminal
VSS, VDD	Power supply terminal
INH	Display turn off input terminal INH="L": V <sub>ss</sub> , turn off (S1-S53, COM1, 2="L") INH="H": V <sub>DD</sub> , turn on
OPEN	No connection

**23) BA4425F (XA0304)**  
FM Front End IC

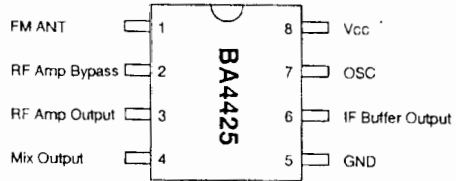

Vcc=4V

Parameter	Symbol	Condition	Min	Typ	Max	Unit
Current	$I_o$	No signal	2.6	4.5	7.2	mA
Saturated output voltage	$V_o$	$f_d=98\text{MHz}$ , $80\text{dB}\mu\text{V}$	30	50	72	mV rms
Local oscillator voltage	$V_{osc}$	$f_{osc}=108\text{MHz}$	200	400	630	mV rms
Conversion gain	$G_{vc}$	$f_d=98\text{MHz}$ , $55\text{dB}\mu\text{V}$	31	36	42	dB
Local oscillator stop voltage	OSC STOP		-	-	1.2	V

**Test Circuit**

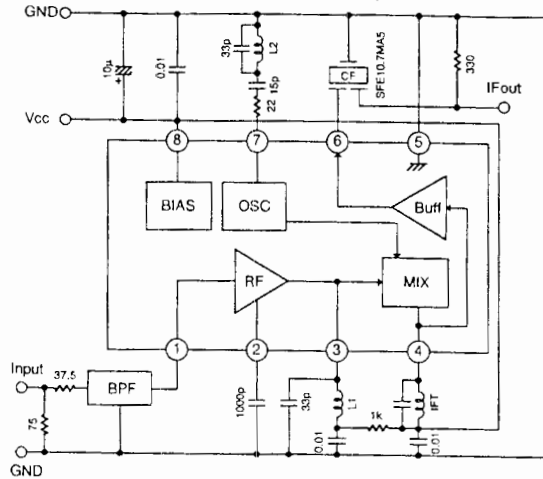

**24) TC74AC74F (XA0305)**  
Dual D-Type Flip Flop

**Truth Table**

INPUTS				OUTPUTS		FUNCTION
CLR	PR	D	CK	Q	$\bar{Q}$	
L	H	X	X	L	H	CLEAR
H	L	X	X	H	L	PRESET
L	L	X	X	H	H	-
H	H	L	$\uparrow$	L	H	-
H	H	H	$\uparrow$	H	L	-
H	H	X	$\uparrow$	$Q_n$	$\bar{Q}_n$	NO CHANGE

X=Don't Care

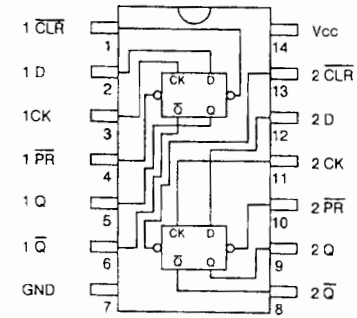

**25) L78LR05B (XA0338)**  
Voltage Regulator

**Block Diagram**

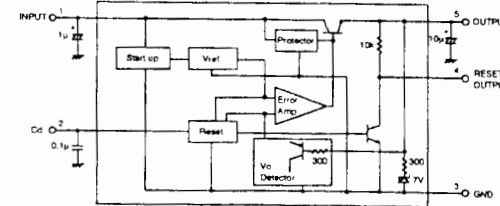

Parameter	Symbol	Ratings	Unit
Input voltage	$V_{in}$	7.5-20	V
Output current	$I_{out}$	1-150	mA
Output voltage	$V_{out}$	5.0	V

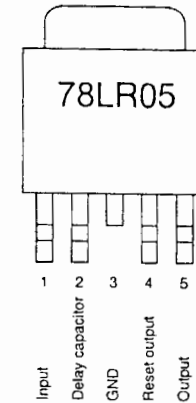

**26) MCT7805 (XA0346)**  
5V Voltage Regulator

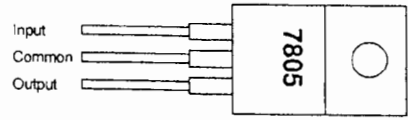

**27) TC4030BF (XA0347)**  
Quad Exclusive-OR Gate

**Truth Table**

Input		Output
A	B	X
L	L	L
L	H	H
H	L	H
H	H	L

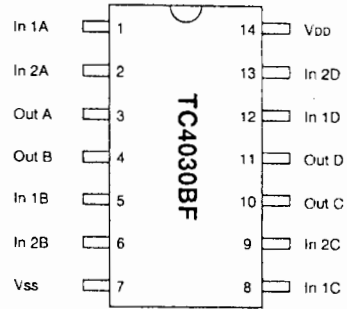
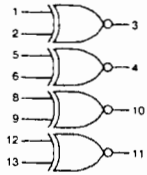

**28) 24LC16B (XA0351)**  
16K bits CMOS Serial EEPROM

**Block Diagram**

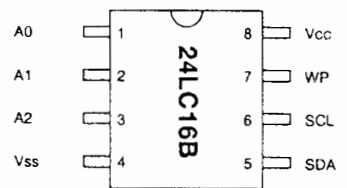
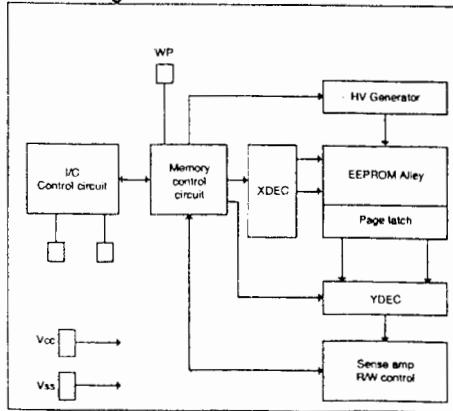

Pin Name	Description
Vss	GND terminal
SDA	Serial address/data I/O
SCL	Serial clock
WP	Write protect
Vcc	+2.5V-5.5V power supply
A0, A1, A2	No connection

**29)  $\mu$ PC1037GR (XA0379)**  
Double Balanced Modulator

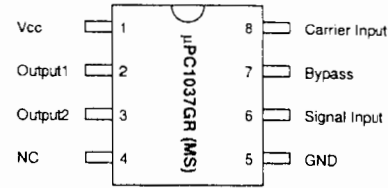

Vcc=6.0V

Characteristics	Symbol	Condition	Min.	Typ.	Max.	Unit
Circuit current	I <sub>cc</sub>	No signal	-	12	16	mA
Conversion gain	G <sub>c</sub>	Signal: 70mV r.m.s. 1.75MHz	-2	0	+2	dB
Signal leakage	L <sub>s</sub>	Carrier: 100mV r.m.s. 28.25MHz	-	-40	-20	dB
Carrier leakage	L <sub>c</sub>	Output: 30MHz	-	-32	-20	dB
Inter modulated distortion	IMD	Signal 1: 42.5mV r.m.s. 1.75MHz Signal 2: 42.5mV r.m.s. 2.00MHz Carrier: 100mV r.m.s. 28.25MHz Output: 29.75MHz	-	-45	-35	dB
Signal input impedance	Z <sub>si</sub>		-	500//9	-	$\Omega$ /pF
Carrier input impedance	Z <sub>ci</sub>		-	1.0//9	-	k $\Omega$ /pF
Output impedance	Z <sub>ol</sub>	Output 1	-	350//7	-	$\Omega$ /pF

**Block Diagram**

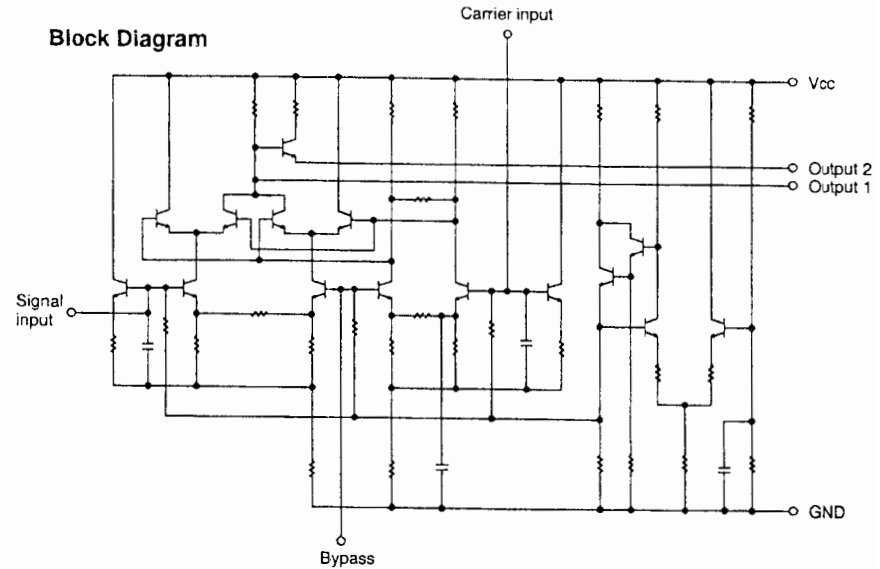

### 30) Transistor, Diode and LED Outline Drawings

Top View

1SS355 XD0254	1SS356 XD0272	1SV217 XD0233	DAN202U XD0230	DAN235U XD0246	DAP202U XD0231	DAP236U XD0266	DTZ4.3B XD0160
DTZ5.6C XD0140	MA27-B XD0263	MA30-B XD0264	MA704WA XD0127	MA728TX XD0234	MI30B XD0014	RLS4152 XD0039	RN711H XD0257
S3275 XD0289	SG5LR XD0265	CL-170G XL0042	CL-170R XL0043	2SK210 XE0006	2SK2171 XE0026	3SK131V12 XE0028	2SA1576 XT0094
2SB1132 XT0061	2SC1971 XT0101	2SC1972 XT0046	2SC2904 XT0128	2SC2954 XT0084	2SC3082 XT0059	2SC3324 XT0080	2SC3419Y XT0127
2SC4081 XT0095	2SC4081LNT XT0111	2SC4099 XT0096	2SD1664 XT0136	DTA114YU XU0112	DTA123EU XU0116	DTA144EU XU0125	DTB123YK XU0155
DTC124EU XU0140	DTC144EU XU0148	FMA4 XT0067	UMA9TR XU0049	UMC3TR XU0047	UN2223 XU0176	UN5111 XU0175	UN5112 XU0174
UN511F XU0051	UN5211 XU0061	UN521L XU0078					

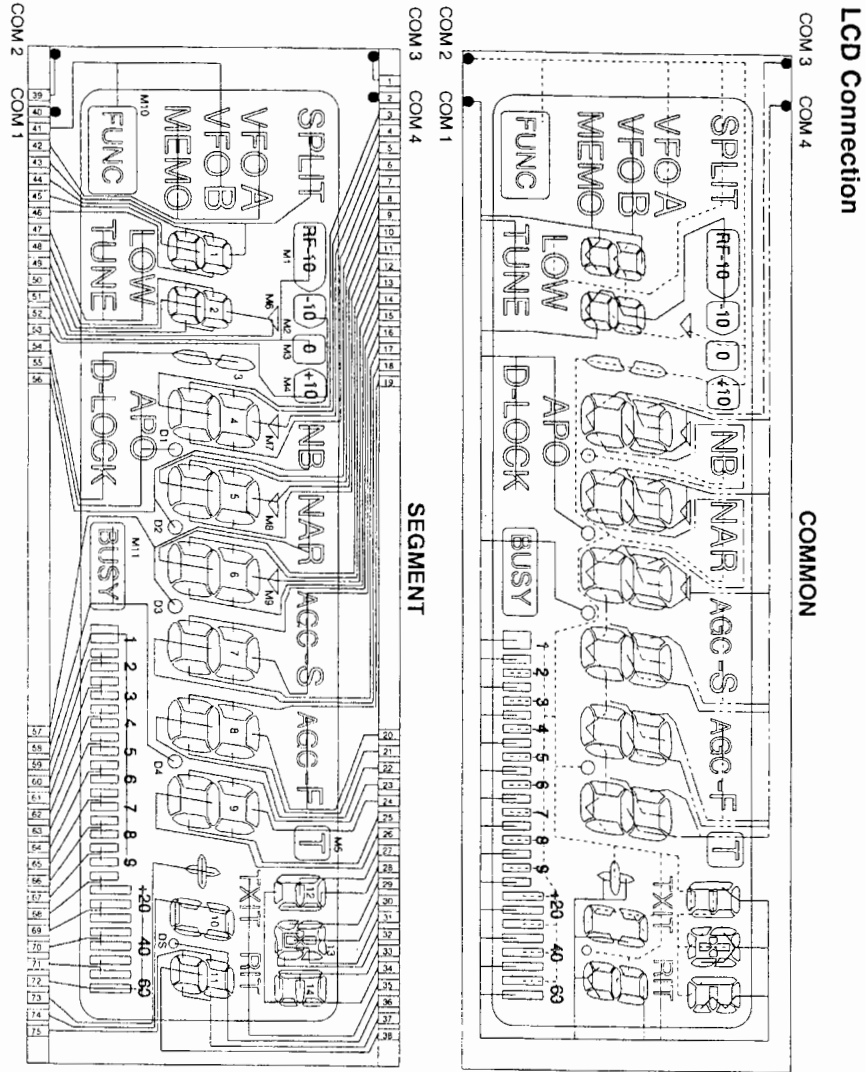

### 31) LCD Connection

# EXPLODED VIEW

## 1) Front Control Unit 1

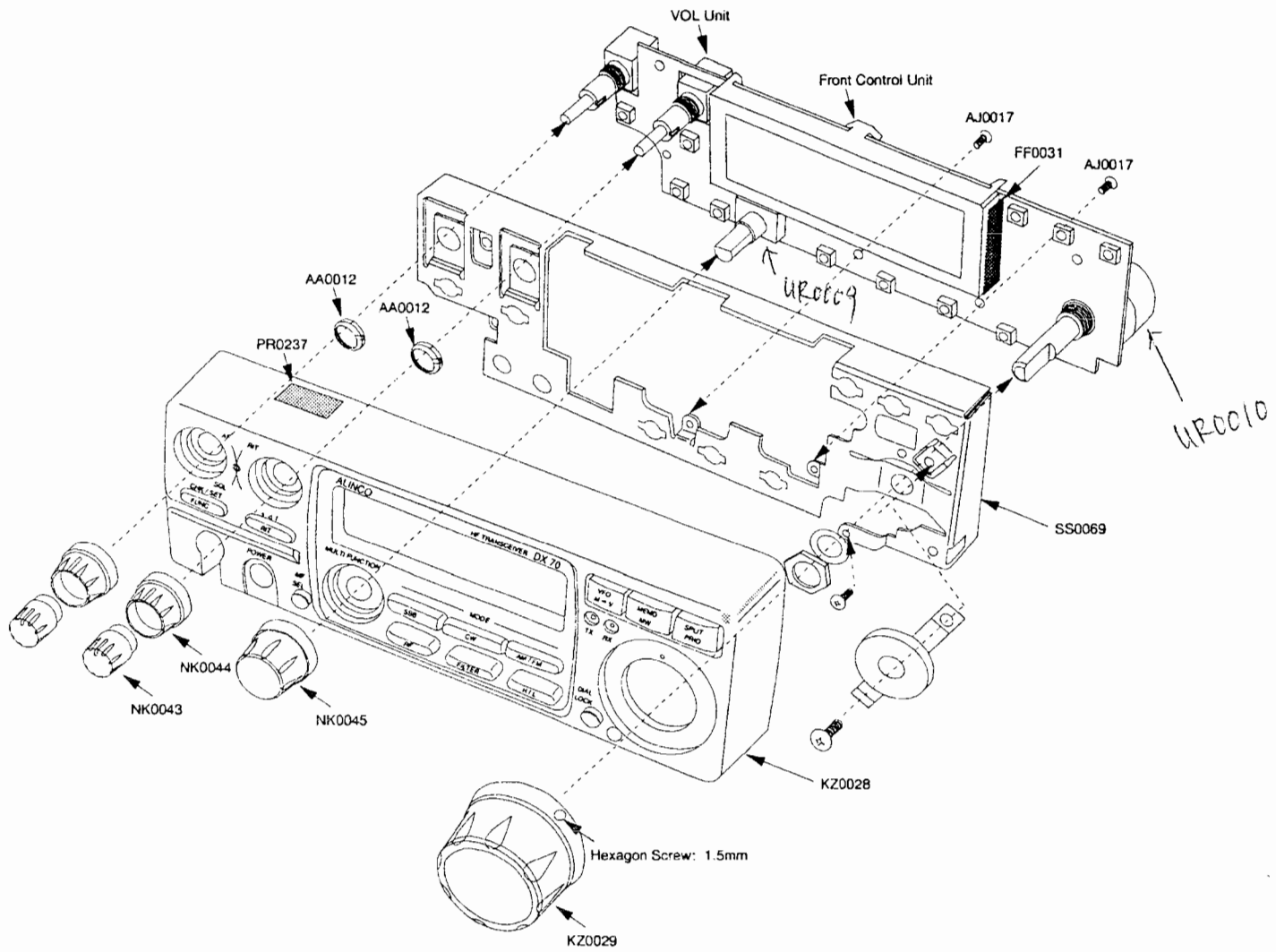

## 2) Front Control Unit 2

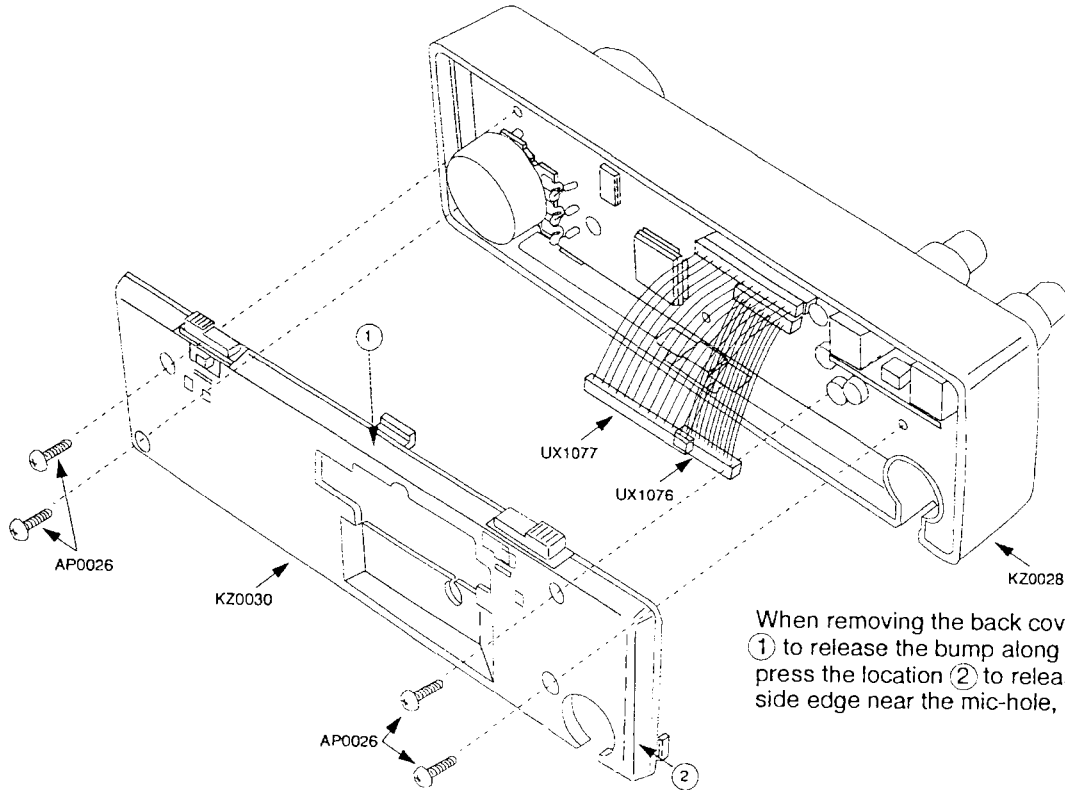

When removing the back cover, press the location ① to release the bump along the top edge, then press the location ② to release the bump along the side edge near the mic-hole, and open.

## 3) LCD Unit

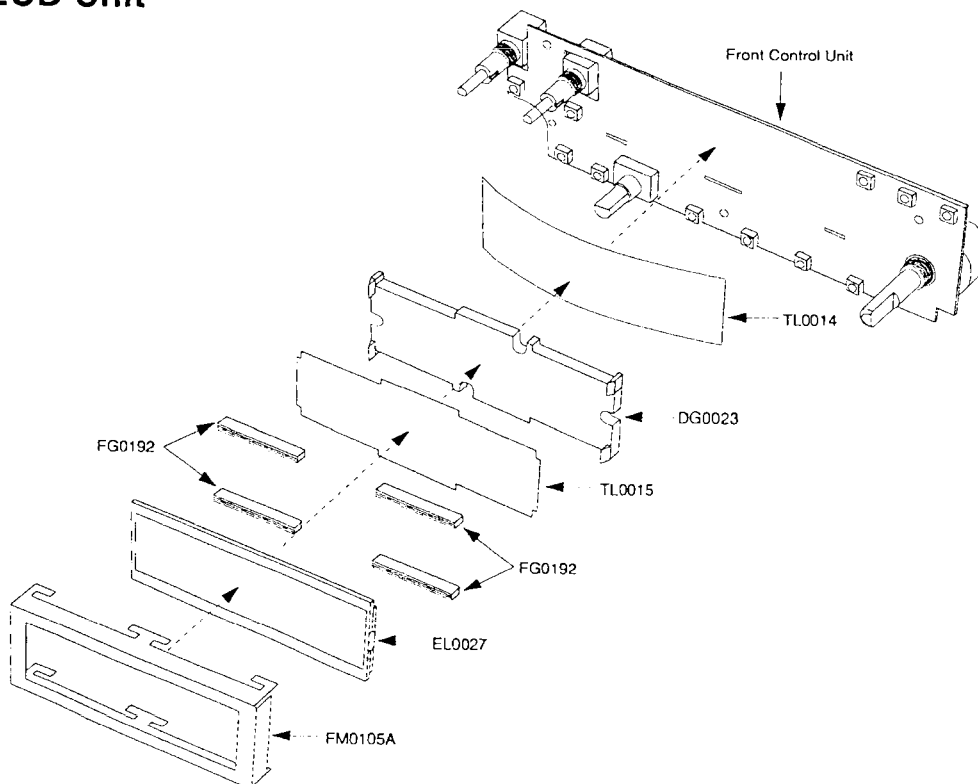

#### 4) PLL Unit and Fan

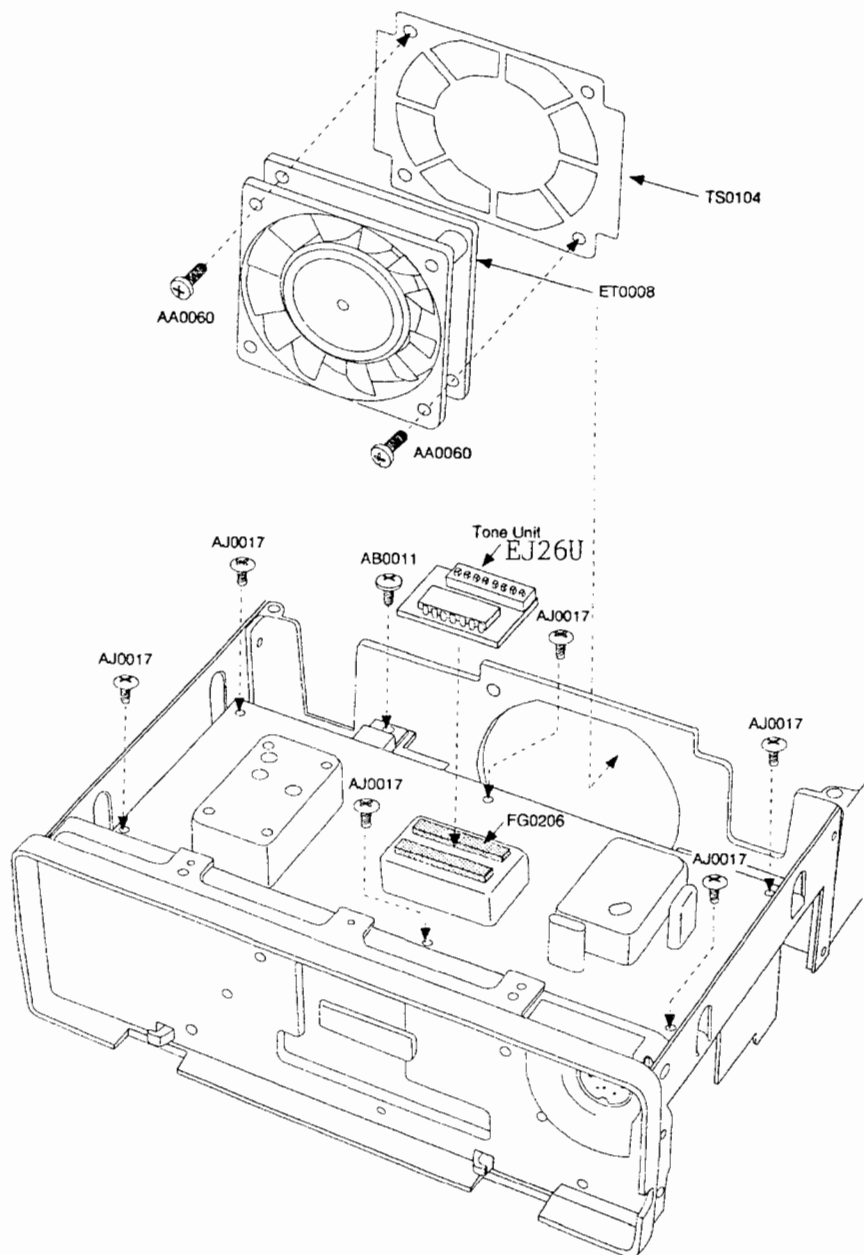



## 5) Top View 1

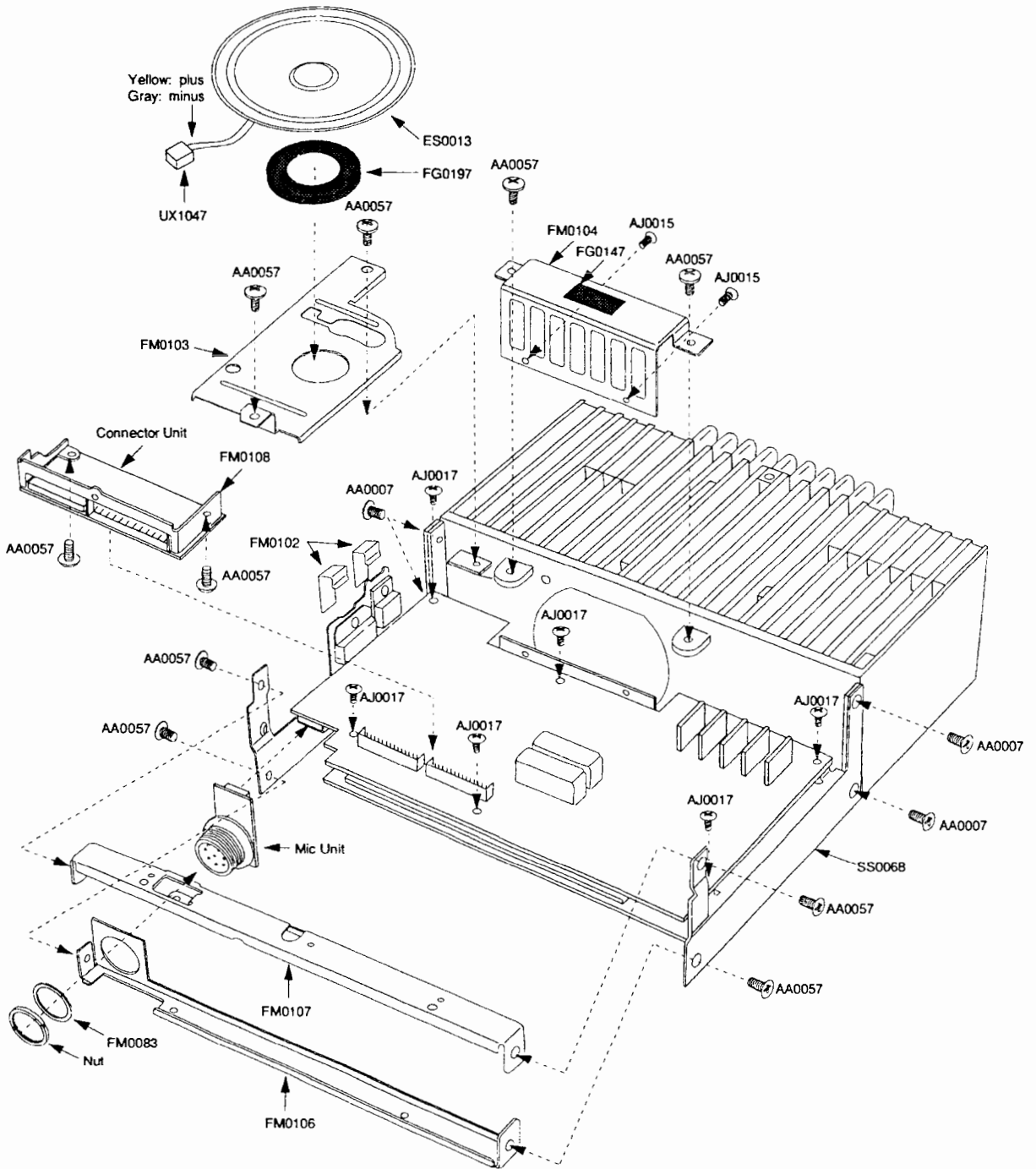

# 6) Top View 2

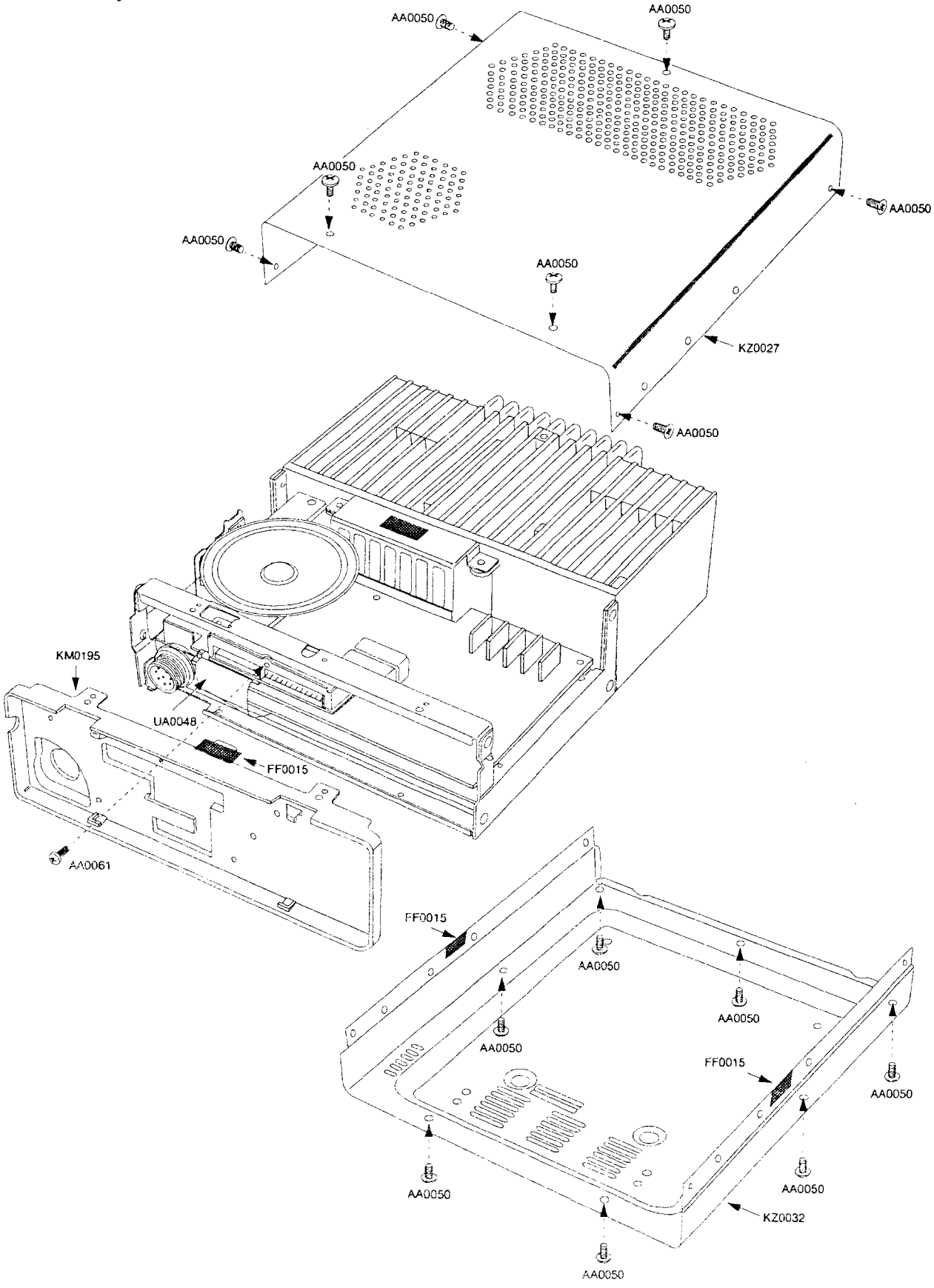

# 7) LPF Unit

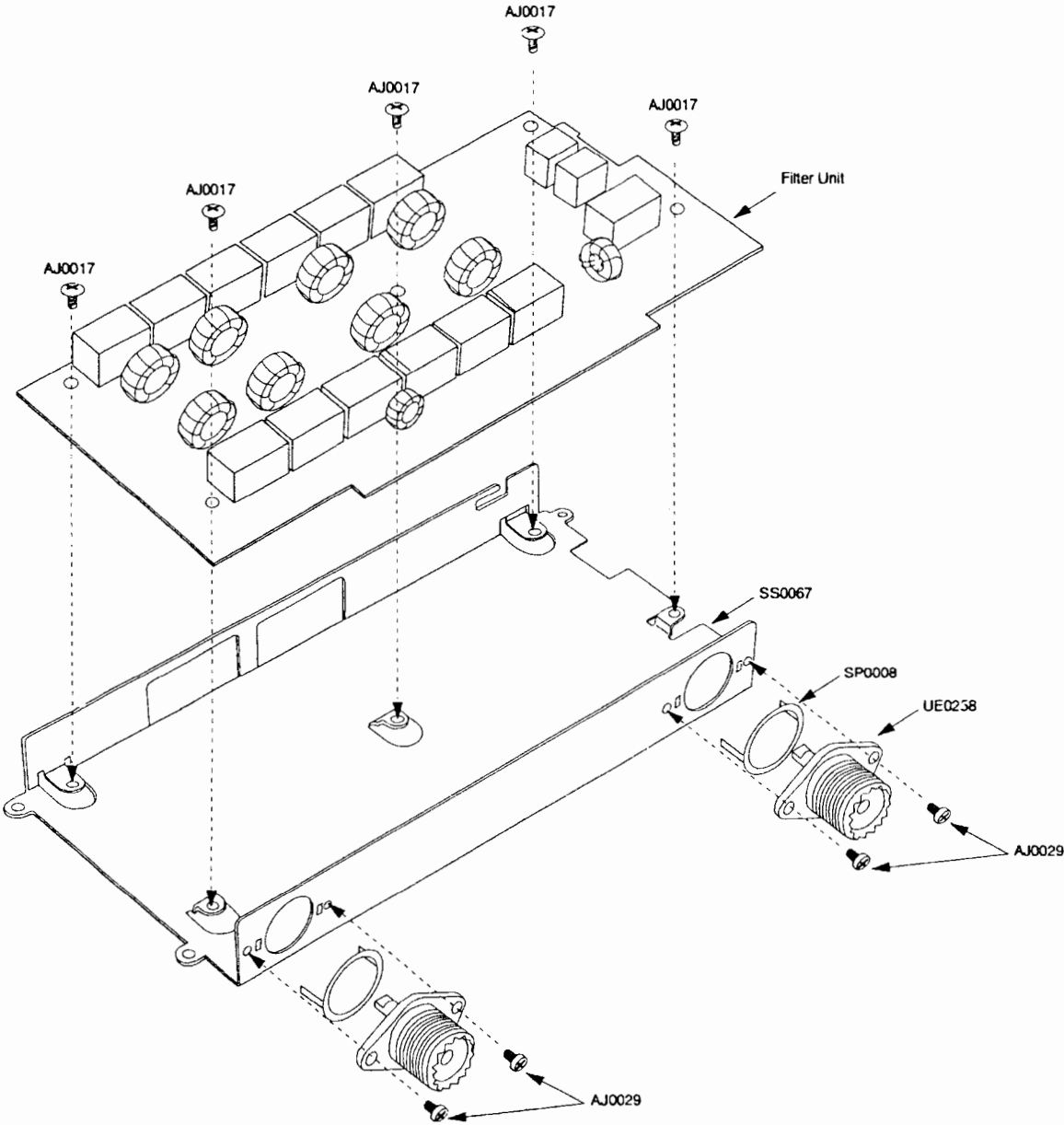

## 8) PA Unit and LPF Unit

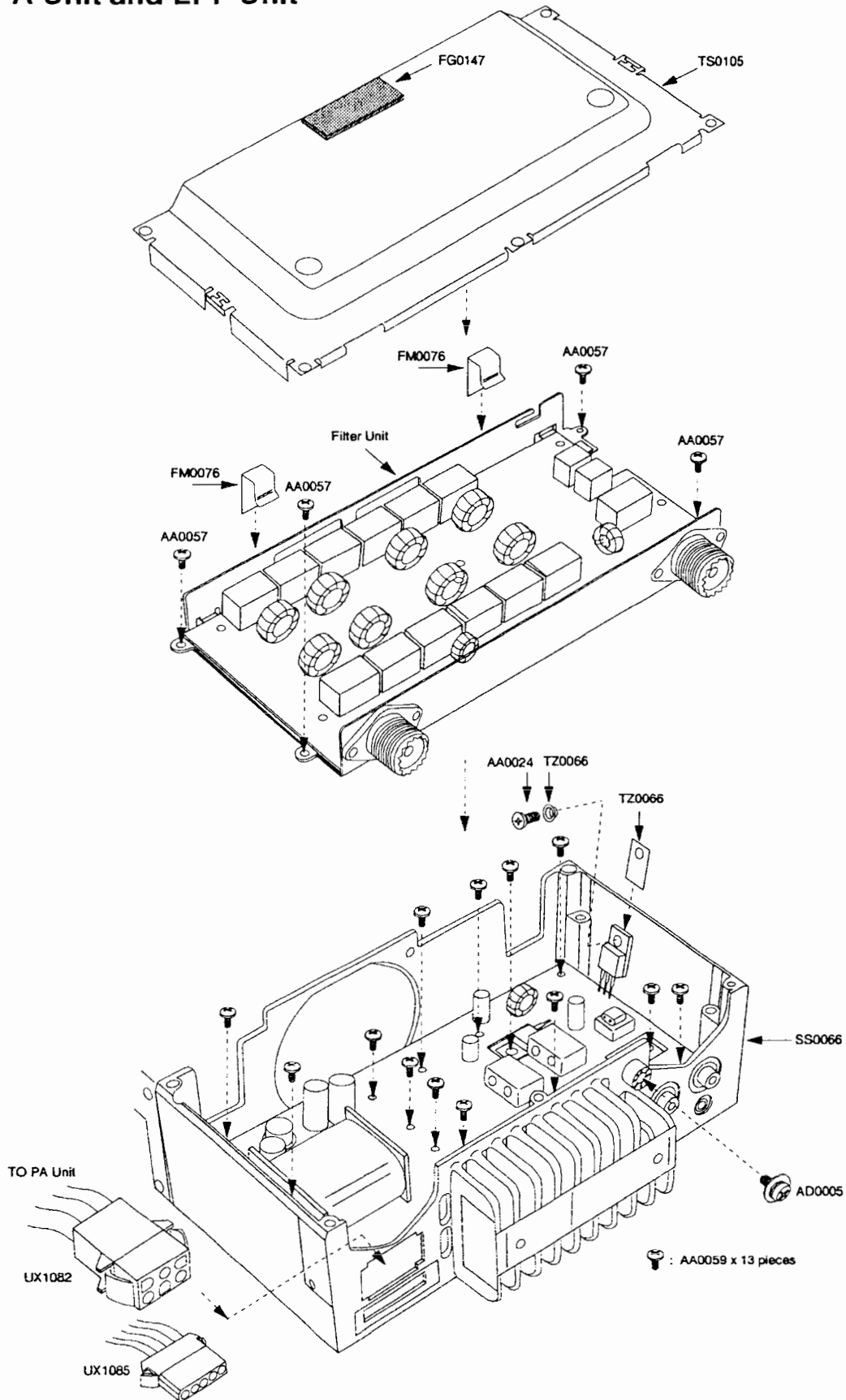

## PARTS LIST

MAIN Unit

Ref. No.	Parts No.	Description	Parts Name
MAIN Unit			
C3	CU3056	Chip C.	C1608JF1E4732T-A
C5	CU3035	Chip C.	C1608JB1H102KT-A
C8	CU3056	Chip C.	C1608JF1E4732T-A
C7	CU3056	Chip C.	C1608JF1E4732T-A
C9	CU3059	Chip C.	C1608JF1E1042T-A
C10	CU3028	Chip C.	C1608CH1H271JT-A
C11	CU3047	Chip C.	C1608JB1H103KT-A
C12	CU3024	Chip C.	C1608CH1H121JT-A
C13	CU3011	Chip C.	C1608CH1H100CT-A
C14	CU3018	Chip C.	C1608CH1H390JT-A
C15	CU3027	Chip C.	C1608CH1H221JT-A
C16	CU3028	Chip C.	C1608CH1H271JT-A
C17	CU3013	Chip C.	C1608CH1H150JT-A
C18	CU3047	Chip C.	C1608JB1H103KT-A
C19	CU3025	Chip C.	C1608CH1H151JT-A
C20	CU3056	Chip C.	C1608JF1E4732T-A
C21	CU3056	Chip C.	C1608JF1E4732T-A
C22	CU3056	Chip C.	C1608JF1E4732T-A
C23	CU3056	Chip C.	C1608JF1E4732T-A
C24	CU3007	Chip C.	C1608CH1H060CT-A
C25	CU3047	Chip C.	C1608JB1H103KT-A
C26	CU3012	Chip C.	C1608CH1H120JT-A
C27	CU3047	Chip C.	C1608JB1H103KT-A
C28	CU3043	Chip C.	C1608JB1H472KT-A
C29	CU3009	Chip C.	C1608CH1H080CT-A
C30	CU3047	Chip C.	C1608JB1H103KT-A
C31	CU3047	Chip C.	C1608JB1H103KT-A
C32	CU3012	Chip C.	C1608CH1H120JT-A
C33	CU3012	Chip C.	C1608CH1H120JT-A
C34	CU3003	Chip C.	C1608CH1H020CT-A
C35	CU3035	Chip C.	C1608JB1H102KT-A
C36	CU3045	Chip C.	C1608JB1H682KT-A
C37	CU3006	Chip C.	C1608CH1H390CT-A
C38	CU3043	Chip C.	C1608JB1H472KT-A
C39	CS0232	Chip Tantalum	TMCMA1V474MTR
C40	CU3056	Chip C.	C1608JF1E4732T-A
C41	CU3031	Chip C.	C1608JB1H471KT-A
C42	CU3056	Chip C.	C1608JF1E4732T-A
C43	CU3056	Chip C.	C1608JF1E4732T-A
C44	CU3047	Chip C.	C1608JB1H103KT-A
C45	CU3047	Chip C.	C1608JB1H103KT-A
C46	CU3056	Chip C.	C1608JF1E4732T-A
C47	CU3038	Chip C.	C1608JB1H182KT-A
C48	CU3037	Chip C.	C1608JB1H152KT-A
C49	CU3038	Chip C.	C1608JB1H182KT-A

Ref. No.	Parts No.	Description	Parts Name
C50	CU3041	Chip C.	C1608JB1H332KT-A
C51	CU8042	Chip C.	C2012JB1C104KT-A
C52	CU3051	Chip C.	C1608JB1E223KT-A
C53	CU3056	Chip C.	C1608JF1E4732T-A
C98	CU3059	Chip C.	C1608JF1E1042T-A
C99	CU3059	Chip C.	C1608JF1E1042T-A
C100	CU3059	Chip C.	C1608JF1E1042T-A
C101	CU3018	Chip C.	C1608CH1H390JT-A
C102	CU3059	Chip C.	C1608JF1E1042T-A
C103	CU3013	Chip C.	C1608CH1H100JT-A
C104	CU3021	Chip C.	C1608CH1H680JT-A
C105	CU3017	Chip C.	C1608CH1H330JT-A
C105	CU3023	Chip C.	C1608CH1H101JT-A
C107	CU3005	Chip C.	C1608CH1H040CT-A
C108	CU3035	Chip C.	C1608JB1H102KT-A
C109	CU3059	Chip C.	C1608JF1E1042T-A
C110	CU3059	Chip C.	C1608JF1E1042T-A
C111	CU3059	Chip C.	C1608JF1E1042T-A
C112	CU3011	Chip C.	C1608CH1H100CT-A
C113	CU3056	Chip C.	C1608JF1E4732T-A
C114	CU3011	Chip C.	C1608CH1H100CT-A
C115	CU3007	Chip C.	C1608CH1H060CT-A
C116	CU3059	Chip C.	C1608JF1E1042T-A
C117	CU3047	Chip C.	C1608JB1H103KT-A
C118	CU3047	Chip C.	C1608JB1H103KT-A
C119	CU3007	Chip C.	C1608CH1H060CT-A
C120	CU3047	Chip C.	C1608JB1H103KT-A
C121	CU3035	Chip C.	C1608JB1H102KT-A
C122	CU3047	Chip C.	C1608JB1H103KT-A
C123	CU3035	Chip C.	C1608JB1H102KT-A
C124	CU3018	Chip C.	C1608CH1H390JT-A
C125	CU3047	Chip C.	C1608JB1H103KT-A
C126	CU3013	Chip C.	C1608CH1H150JT-A
C127	CU3018	Chip C.	C1608CH1H390JT-A
C128	CS0069	Chip Tantalum	TMCSA1V154MTR
C130	CE0310	Electrolytic C.	ECEV1A4330P
C131	CU3035	Chip C.	C1608JB1H102KT-A
C132	CU3056	Chip C.	C1608JF1E4732T-A
C133	CU3056	Chip C.	C1608JF1E4732T-A
C134	CU3031	Chip C.	C1608JB1H471KT-A
C135	CU3056	Chip C.	C1608JF1E4732T-A
C136	CU3056	Chip C.	C1608JF1E4732T-A
C137	CU3056	Chip C.	C1608JF1E4732T-A
C138	CU3031	Chip C.	C1608JB1H471KT-A
C139	CE0315	Electrolytic C.	ECEV1CA470P
C140	CU3056	Chip C.	C1608JF1E4732T-A

Ref. No.	Parts No.	Description	Parts Name
C141	CU3056	Chip C.	C1608JF1E4732T-A
C142	CU3031	Chip C.	C1608JB1H471KT-A
C143	CU30562	Chip C.	C1608JF1E4732T-A
C144	CU3056	Chip C.	C1608JF1E4732T-A
C145	CU3056	Chip C.	C1608JF1E4732T-A
C146	CU3015	Chip C.	C1608CH1H220JT-A
C147	CU3056	Chip C.	C1608JF1E4732T-A
C148	CU3031	Chip C.	C1608JB1H471KT-A
C149	CU3051	Chip C.	C1608JB1E223KT-A
C150	CU3056	Chip C.	C1608JF1E4732T-A
C151	CU3056	Chip C.	C1608JF1E4732T-A
C152	CU3056	Chip C.	C1608JF1E4732T-A
C153	CU3056	Chip C.	C1608JF1E4732T-A
C154	CU3056	Chip C.	C1608JF1E4732T-A
C155	CU3056	Chip C.	C1608JF1E4732T-A
C156	CU3056	Chip C.	C1608JF1E4732T-A
C157	CU3056	Chip C.	C1608JF1E4732T-A
C158	CU3056	Chip C.	C1608JF1E4732T-A
C159	CU3056	Chip C.	C1608JF1E4732T-A
C160	CU3056	Chip C.	C1608JF1E4732T-A
C161	CU3056	Chip C.	C1608JF1E4732T-A
C162	CU3039	Chip C.	C1608JB1H222KT-A
C163	CU3056	Chip C.	C1608JF1E4732T-A
C164	CU3056	Chip C.	C1608JF1E4732T-A
C165	CU3056	Chip C.	C1608JF1E4732T-A
C166	CU3031	Chip C.	C1608JB1H471KT-A
C167	CU3056	Chip C.	C1608JF1E4732T-A
C168	CU3031	Chip C.	C1608JB1H471KT-A
C169	CU3056	Chip C.	C1608JF1E4732T-A
C170	CU3027	Chip C.	C1608CH1H221JT-A
C171	CU3056	Chip C.	C1608JF1E4732T-A
C172	CU3056	Chip C.	C1608JF1E4732T-A
C173	CU3035	Chip C.	C1608JB1H102KT-A
C174	CU3051	Chip C.	C1608JB1E223KT-A
C175	CU3056	Chip C.	C1608JF1E4732T-A
C176	CU3056	Chip C.	C1608JF1E4732T-A
C177	CU3037	Chip C.	C1608JB1H152KT-A
C178	CU3047	Chip C.	C1608JB1H103KT-A
C179	CU3056	Chip C.	C1608JF1E4732T-A
C180	CS0372	Chip Tantalum	TMCMB1C106MTR
C181	CU3056	Chip C.	C1608JF1E4732T-A
C182	CU3051	Chip C.	C1608JB1E223KT-A
C183	CU3056	Chip C.	C1608JF1E4732T-A
C184	CU3056	Chip C.	C1608JF1E4732T-A
C185	CU3056	Chip C.	C1608JF1E4732T-A
C186	CU3056	Chip C.	C1608JF1E4732T-A

Ref. No.	Parts No.	Description	Parts Name
C187	CU3056	Chip C.	C1608JF1E4732T-A
C188	CU3056	Chip C.	C1608JF1E4732T-A
C189	CS0372	Chip Tantalum	TMCMB1C106MTR
C190	CU3102	Chip C.	C1608JB1C333KT-A
C191	CU8042	Chip C.	C2012JB1C104KT-A
C192	CU3047	Chip C.	C1608JB1H103KT-A
C193	CU3047	Chip C.	C1608JB1H103KT-A
C194	CU3047	Chip C.	C1608JB1H103KT-A
C195	CU3047	Chip C.	C1608JB1H103KT-A
C196	CS0372	Chip Tantalum	TMCMB1C106MTR
C197	CU3045	Chip C.	C1608JB1H682KT-A
C198	CU3102	Chip C.	C1608JB1C333KT-A
C199	CU3029	Chip C.	C1608JB1H331KT-A
C200	CS0230	Chip Tantalum	TMCMA1E105MTR
C201	CU3018	Chip C.	C1608CH1H390JT-A
C202	CU3029	Chip C.	C1608JB1H331KT-A
C203	CU3056	Chip C.	C1608JF1E4732T-A
C204	CS0061	Chip Tantalum	TMCMA1V224MTR
C205	CS0230	Chip Tantalum	TMCMA1E105MTR
C206	CU3101	Chip C.	C1608JB1C473KT-A
C207	CU3059	Chip C.	C1608JF1E1042T-A
C208	CU3059	Chip C.	C1608JF1E1042T-A
C209	CU3059	Chip C.	C1608JF1E1042T-A
C210	CU3025	Chip C.	C1608CH1H151JT-A
C211	CU3027	Chip C.	C1608CH1H221JT-A
C212	CU3059	Chip C.	C1608JF1E1042T-A
C213	CS0372	Chip Tantalum	TMCMB1C106MTR
C214	CU3051	Chip C.	C1608JB1E223KT-A
C215	CU3047	Chip C.	C1608JB1H103KT-A
C216	CU3047	Chip C.	C1608JB1H103KT-A
C217	CU8042	Chip C.	C2012JB1C104KT-A
C218	CU3047	Chip C.	C1608JB1H103KT-A
C219	CU3047	Chip C.	C1608JB1H103KT-A
C220	CU3059	Chip C.	C1608JF1E1042T-A
C221	CS0372	Chip Tantalum	TMCMB1C106MTR
C222	CS0230	Chip Tantalum	TMCMA1E105MTR
C223	CS0372	Chip Tantalum	TMCMB1C106MTR
C224	CU3047	Chip C.	C1608JB1H103KT-A
C225	CU3047	Chip C.	C1608JB1H103KT-A
C226	CS0230	Chip Tantalum	TMCMA1E105MTR
C227	CS0225	Chip Tantalum	TMCMA1D155MTR
C228	CU3047	Chip C.	C1608JB1H103KT-A
C229	CE0312	Electrolytic C.	ECEV1CA100R
C230	CU3047	Chip C.	C1608JB1H103KT-A
C231	CE0315	Electrolytic C.	ECEV1CA470P
C232	CU3026	Chip C.	C1608CH1H181JT-A

Ref. No.	Parts No.	Description	Parts Name
C233	CU3043	Chip C.	C1608JB1H472KT-A
C234	CU3038	Chip C.	C1608JB1H182KT-A
C236	CU3059	Chip C.	C1608JF1E1042T-A
C237	CU3059	Chip C.	C1608JF1E1042T-A
C238	CS0367	ChipTantalum	TMCMA0J106MTR
C239	CU3059	Chip C.	C1608JF1E1042T-A
C240	CU8042	Chip C.	C2012JB1C104KT-A
C241	CS0372	ChipTantalum	TMCMB1C106MTR
C242	CU3047	Chip C.	C1608JB1H103KT-A
C243	CU3101	Chip C.	C1608JB1C473KT-A
C244	CS0371	ChipTantalum	TMCMA1C335MTR
C245	CS0372	ChipTantalum	TMCMB1C106MTR
C246	CU3041	Chip C.	C1608JB1H332KT-A
C247	CS0230	ChipTantalum	TMCMA1E105MTR
C248	CS0230	ChipTantalum	TMCMA1E105MTR
C249	CU3101	Chip C.	C1608JB1C473KT-A
C250	CS0220	ChipTantalum	TMCMA1C225MTR
C251	CS0220	ChipTantalum	TMCMA1C225MTR
C252	CU3047	Chip C.	C1608JB1H103KT-A
C253	CU3056	Chip C.	C1608JF1E4732T-A
C254	CS0372	ChipTantalum	TMCMB1C106MTR
C255	CU3056	Chip C.	C1608JF1E4732T-A
C256	CU3102	Chip C.	C1608JB1C333KT-A
C257	CU3029	Chip C.	C1608JB1H331KT-A
C258	CS0229	ChipTantalum	TMCMA1E684MTR
C259	CU3051	Chip C.	C1608JB1E223KT-A
C260	CE0315	Electrolytic C.	ECEV1CA470P
C261	CE0352	Electrolytic C.	16MV330HC
C262	CU8042	Chip C.	C2012JB1C104KT-A
C263	CE0353	Electrolytic C.	16MV470HC
C264	CE0315	Electrolytic C.	ECEV1CA470P
C265	CE0315	Electrolytic C.	ECEV1CA470P
C266	CE0315	Electrolytic C.	ECEV1CA470P
C267	CU3056	Chip C.	C1608JF1E4732T-A
C268	CU8042	Chip C.	C2012JB1C104KT-A
C269	CS0230	ChipTantalum	TMCMA1E105MTR
C270	CU3059	Chip C.	C1608JF1E1042T-A
C271	CU3059	Chip C.	C1608JF1E1042T-A
C272	CU3026	Chip C.	C1608CH1H181JT-A
C273	CU3043	Chip C.	C1608JB1H472KT-A
C274	CU3039	Chip C.	C1608JB1H222KT-A
C275	CU3047	Chip C.	C1608JB1H103KT-A
C276	CS0372	ChipTantalum	TMCMB1C106MTR
C277	CU3051	Chip C.	C1608JB1E223KT-A
C278	CU8042	Chip C.	C2012JB1C104KT-A
C279	CU3047	Chip C.	C1608JB1H103KT-A

Ref. No.	Parts No.	Description	Parts Name
C280	CS0230	ChipTantalum	TMCMA1E105MTR
C281	CE0315	Electrolytic C.	ECEV1CA470P
C282	CS0232	ChipTantalum	TMCMA1V474MTR
C283	CU3047	Chip C.	C1608JB1H103KT-A
C284	CU5027	Chip C.	C1608CH1H221JT-A
C285	CU3027	Chip C.	C1608CH1H221JT-A
C286	CU3027	Chip C.	C1608CH1H221JT-A
C287	CS0210	ChipTantalum	TMCMB0J156MTR
C289	CU3056	Chip C.	C1608JF1E4732T-A
C290	CU3047	Chip C.	C1608JB1H103KT-A
C291	CU3047	Chip C.	C1608JB1H103KT-A
C292	CU3047	Chip C.	C1608JB1H103KT-A
C293	CU3047	Chip C.	C1608JB1H103KT-A
C294	CU3059	Chip C.	C1608JF1E1042T-A
C296	CU3047	Chip C.	C1608JB1H103KT-A
C297	CU3059	Chip C.	C1608JF1E1042T-A
C298	CU8042	Chip C.	C2012JB1C104KT-A
C299	CU3047	Chip C.	C1608JB1H103KT-A
C300	CU3035	Chip C.	C1608JB1H102KT-A
C301	CU3047	Chip C.	C1608JB1H103KT-A
C302	CU3047	Chip C.	C1608JB1H103KT-A
C303	CU3047	Chip C.	C1608JB1H103KT-A
C304	CU3047	Chip C.	C1608JB1H103KT-A
C305	CU3047	Chip C.	C1608JB1H103KT-A
C306	CU3047	Chip C.	C1608JB1H103KT-A
C307	CU3047	Chip C.	C1608JB1H103KT-A
C308	CU3047	Chip C.	C1608JB1H103KT-A
C309	CU3047	Chip C.	C1608JB1H103KT-A
C310	CU3027	Chip C.	C1608JB1H103KT-A
C311	CU3047	Chip C.	C1608JB1H103KT-A
C312	CU3056	Chip C.	C1608JF1E4732T-A
C313	CU3047	Chip C.	C1608JB1H103KT-A
C314	CU3047	Chip C.	C1608JB1H103KT-A
C315	CU3027	Chip C.	C1608CH1H221JT-A
C316	CU3027	Chip C.	C1608CH1H221JT-A
C317	CU3027	Chip C.	C1608CH1H221JT-A
C318	CU3027	Chip C.	C1608CH1H221JT-A
C319	CU3027	Chip C.	C1608CH1H221JT-A
C320	CU3027	Chip C.	C1608CH1H221JT-A
C321	CU3027	Chip C.	C1608CH1H221JT-A
C322	CU3027	Chip C.	C1608CH1H221JT-A
C323	CU3047	Chip C.	C1608JB1H103KT-A
C324	CU3059	Chip C.	C1608JF1E1042T-A
C325	CS0230	ChipTantalum	TMCMA1E105MTR
C326	CU3047	Chip C.	C1608JB1H103KT-A
C327	CU3047	Chip C.	C1608JB1H103KT-A

Ref. No.	Parts No.	Description	Parts Name
C328	CU3047	Chip C.	C1608JB1H103KT-A
C329	CU3047	Chip C.	C1608JB1H103KT-A
C330	CU3047	Chip C.	C1608JB1H103KT-A
C331	CU3039	Chip C.	C1608JB1H222KT-A
C332	CU3047	Chip C.	C1608JB1H103KT-A
C333	CU3047	Chip C.	C1608JB1H103KT-A
C334	CU3047	Chip C.	C1608JB1H103KT-A
C335	CU3047	Chip C.	C1608JB1H103KT-A
C336	CU3047	Chip C.	C1608JB1H103KT-A
C337	CU3047	Chip C.	C1608JB1H103KT-A
C338	CU3047	Chip C.	C1608JB1H103KT-A
C339	CU3047	Chip C.	C1608JB1H103KT-A
C340	CU3047	Chip C.	C1608JB1H103KT-A
C341	CU3047	Chip C.	C1608JB1H103KT-A
C342	CU3047	Chip C.	C1608JB1H103KT-A
C343	CS0372	ChipTantalum	TMCMB1C106MTR
C344	CU3047	Chip C.	C1608JB1H103KT-A
C345	CU3044	Chip C.	C1608JB1H562KT-A
C346	CU3047	Chip C.	C1608JB1H103KT-A
C347	CU3027	Chip C.	C1608CH1H221JT-A
C348	CU8042	Chip C.	C2012JB1C104KT-A
C349	CU3056	Chip C.	C1608JF1E4732T-A
C350	CU3056	Chip C.	C1608JF1E4732T-A
C351	CU3035	Chip C.	C1608JB1H102KT-A
C352	CU3004	Chip C.	C1608CH1H030CT-A
C353	CU3047	Chip C.	C1608JB1H103KT-A
CN1	UE0235	Connector	00-6208-000-112-001
CN2	UE0043	Connector	PI22A02M
CN3	UE0070	Connector	PI22A04M
CN4	UE0071	Connector	PI22A05M
CN5	UE0044	Connector	PI22A09M
CN6	UE0259	Connector	CFP0526-0201
CN9	UE0260	Connector	09PS-JE
CN11	UE0043	Connector	PI22A02M
CN12	UE0262	Connector	1MSA-91208-13
CN13	UE0262	Connector	1MSA-91208-13
D1	XD0272	Diode	1SS356 TW11
D2	XD0272	Diode	1SS356 TW11
D4	XD0266	Diode	DAP236U T106
D5	XD0254	Diode	1SS355 TE-17
D6	XD0246	Diode	DAN235UT106
D7	XD0289	Diode	S3275(TE12L)
D8	XD0246	Diode	DAN235UT106
D9	XD0246	Diode	DAN235UT106
D10	XD0231	Diode	DAP202U T106
D11	XD0231	Diode	DAP202U T106

Ref. No.	Parts No.	Description	Parts Name
D29	XD0246	Diode	DAN235UT106
D30	XD0246	Diode	DAN235UT106
D33	XD0234	Diode	MA728 TX
D34	XD0234	Diode	MA728 TX
D37	XD0272	Diode	1SS356 TW11
D38	XD0272	Diode	1SS356 TW11
D39	XD0272	Diode	1SS356 TW11
D40	XD0272	Diode	1SS356 TW11
D41	XD0272	Diode	1SS356 TW11
D42	XD0272	Diode	1SS356 TW11
D43	XD0272	Diode	1SS356 TW11
D44	XD0272	Diode	1SS356 TW11
D45	XD0272	Diode	1SS356 TW11
D46	XD0272	Diode	1SS356 TW11
D47	XD0272	Diode	1SS356 TW11
D48	XD0272	Diode	1SS356 TW11
D49	XD0246	Diode	DAN235UT106
D50	XD0254	Diode	1SS355 TE-17
D51	XD0234	Diode	MA728 TX
D52	XD0272	Diode	1SS356 TW11
D53	XD0234	Diode	MA728 TX
D54	XD0234	Diode	MA728 TX
D55	XD0230	Diode	DAN202U T106
D56	XD0230	Diode	DAN202U T106
D57	XD0254	Diode	1SS355 TE-17
D58	XD0254	Diode	1SS355 TE-17
D59	XD0231	Diode	DAP202U T106
D60	XD0254	Diode	1SS355 TE-17
D62	XD0254	Diode	1SS355 TE-17
D63	XD0231	Diode	DAP202U T106
D64	XD0140	Diode	DTZ5.6C TT11
D65	XD0254	Diode	1SS355 TE-17
D66	XD0254	Diode	1SS355 TE-17
D67	XD0231	Diode	DAP202U T106
D68	XD0230	Diode	DAN202U T106
D69	XD0254	Diode	1SS355 TE-17
D70	XD0254	Diode	1SS355 TE-17
D71	XD0231	Diode	DAP202U T106
D72	XD0254	Diode	1SS355 TE-17
D73	XD0254	Diode	1SS355 TE-17
D74	XD0254	Diode	1SS355 TE-17
D75	XD0254	Diode	1SS355 TE-17
D76	XD0254	Diode	1SS355 TE-17
D77	XD0254	Diode	1SS355 TE-17
D78	XD0254	Diode	1SS355 TE-17
D79	XD0254	Diode	1SS355 TE-17

## MAIN Unit

Ref. No.	Parts No.	Description	Parts Name
D80	XD0230	Diode	DAN202U T106
D82	XD0230	Diode	DAN202U T106
D83	XD0254	Diode	1SS355 TE-17
D84	XD0254	Diode	1SS355 TE-17
D85	XD0254	Diode	1SS355 TE-17
D86	XD0231	Diode	DAP202U T106
D88	XD0254	Diode	1SS355 TE-17
D89	XD0231	Diode	DAP202U T106
D90	XD0230	Diode	DAN202U T106
D91	XD0230	Diode	DAN202U T106
D92	XD0254	Diode	1SS355 TE-17
D93	XD0231	Diode	DAP202U T106
D94	XD0230	Diode	DAN202U T106
D95	XD0231	Diode	DAP202U T106
D96	XD0254	Diode	1SS355 TE-17
D97	XD0254	Diode	1SS355 TE-17
D99	XD0254	Diode	1SS355 TE-17
D100	XD0254	Diode	1SS355 TE-17
D101	XD0230	Diode	DAN202U T106
D102	XD0230	Diode	DAN202U T106
D103	XD0254	Diode	1SS355 TE-17
D104	XD0254	Diode	1SS355 TE-17
D106	XD0230	Diode	DAN202U T106
D107	XD0254	Diode	1SS355 TE-17
D108	XD0230	Diode	DAN202U T106
D109	XD0230	Diode	DAN202U T106
D110	XD0254	Diode	1SS355 TE-17
D111	XD0254	Diode	1SS355 TE-17
FB1	QB0037	Ferrite Beads	ZBF253D-00
FL1	XF0017	Crystal Filter	71M15B4 UM1
FL2	XC0012		Ceramic Filter CFJ455K8
FL3	XC0011	Ceramic Filter	CFJ455K5
FL4	XC0017	Ceramic Filter	CFW455G
FL5	XF0021	Crystal Filter	71M15A2
IC2	XA0300	IC	AN612
IC3	XA0300	IC	AN612
IC4	XA0224	IC	NJM2904M-T1
IC5	XA0236	IC	BU4052BCF-T1
IC6	XA0115	IC	TC4556F-TE85L
IC7	XA0063	IC	MC3357DR
IC8	XA0224	IC	NJM2904M-T1
IC9	XA0224	IC	NJM2904M-T1
IC10	XA0299	IC	BU4001BF
IC11	XA0082	IC	MC7808CT
IC12	XA0068	IC	MS218FP-T01-1
IC13	XA0301	IC	MS222FP

Ref. No.	Parts No.	Description	Parts Name
IC14	XA0224	IC	NJM2904M-T1
IC15	XA0246	IC	BU4094BF-T1
IC16	XA0114	IC	UPD6345GS-T1
IC17	XA0224	IC	NJM2904M-T1
IC18	XA0299	IC	BU4001BF
IC19	XA0294	IC	MC74HC390FL2
IC20	XA0079	IC	MPC1241H
IC21	XA0068	IC	MS218FP-T01-1
IC22	XA0114	IC	UPD6345GS-T1
IC23	XA0114	IC	UPD6345GS-T1
IC24	XA0299	IC	BU4001BF
J1	UE0041	Connector	TMP-J01X-V6
J3	UE0041	Connector	TMP-J01X-V6
J4	UE0041	Connector	MP-J01X-V6
J5	UE0041	Connector	TMP-J01X-V6
L2	QR0017	Coil	QR0017
L3	QC0061	Chip L.	NL322522T-033J
L4	QC0126	Chip L.	NL322522T-R22J-3
L5	QC0039	Chip L.	NL322522T-1R0J
L6	QC0127	Chip L.	NL322522T-R27J-3
L7	QC0061	Chip L.	NL322522T-033J
L8	QR0017	Coil	QR0017
L9	QA0108	Coil	QA0108
L10	QA0107	Coil	QA0107
L11	QA0107	Coil	QA0107
L12	QA0107	Coil	QA0107
L13	QA0107	Coil	QA0107
L14	QR0017	Coil	QR0017
L15	QC0039	Chip L.	NL322522T-1R0J
L16	QR0017	Coil	QR0017
L17	QC0078	Chip L.	NL322522T-220J
L18	QA0119	Coil	QA0119
L19	QC0074	Chip L.	NL322522T-8R2J
L20	QC0072	Chip L.	NL322522T-5R6J
L21	QC0493	Chip L.	L0H4N471J04
L48	QC0493	Chip L.	L0H4N471J04
L49	QC0493	Chip L.	L0H4N471J04
L50	QC0493	Chip L.	L0H4N471J04
L51	QR0017	Coil	QR0017
L52	QC0124	Chip L.	NL322522T-R15J-3
L53	QC0124	Chip L.	NL322522T-R15J-3
L54	QC0124	Chip L.	NL322522T-R15J-3
L55	QR0017	Coil	QR0017
L56	QA0108	Coil	QA0108
L57	QA0107	Coil	QA0107
L58	QA0107	Coil	QA0107

Ref. No.	Parts No.	Description	Parts Name
L59	QA0107	Coil	QA0107
L60	QC0047	Chip L.	NL322522T-4R7J
L61	QC0062	Chip L.	NL322522T-039J
L62	QC0123	Chip L.	NL322522T-R12J-3
L63	QA0119	Coil	QA0119
L64	QA0119	Coil	QA0119
L65	QA0119	Coil	QA0119
L66	QA0119	Coil	QA0119
L67	QC0493	Chip L.	L0H4N471J04
L68	QA0119	Coil	QA0119
L69	QA0119	Coil	QA0119
L70	QC0048	Chip L.	NL322522T-100J
L71	QC0048	Chip L.	NL322522T-100J
L72	QC0039	Chip L.	NL322522T-1R0J
L73	QC0078	Chip L.	NL322522T-220J
L75	QC0040	Chip L.	NL322522T-1R2J
L76	QC0048	Chip L.	NL322522T-100J
L77	QC0086	Chip L.	NL322522T-101J
L80	QR0017	Coil	QR0017
L81	QC0044	Chip L.	NL322522T-2R7J
01	XT0084	Transistor	2SC2954-T1
03	XE0028	FET	3SK131V12T1
04	XE0028	FET	3SK131V12T1
05	XE0028	FET	3SK131V12T1
06	XU0061	Transistor	UN5211-TX
07	XE0028	FET	3SK131V12T1
08	XE0026	FET	2SK2171-4
09	XE0026	FET	2SK2171-4
010	XE0026	FET	2SK2171-4
011	XE0026	FET	2SK2171-4
012	XE0028	FET	3SK131V12T1
013	XT0084	Transistor	2SC2954-T1
014	XT0094	Transistor	2SA1576T106R
015	XT0095	Transistor	2SC4081T106R
016	XT0095	Transistor	2SC4081T106R
018	XT0095	Transistor	2SC4081T106R
019	XT0095	Transistor	2SC4081T106R
020	XE0028	FET	FE3SK131V12T1
021	XU0078	Transistor	UN521L-TX
022	XE0028	FET	3SK131V12T1
023	XE0028	FET	3SK131V12T1
024	XE0028	FET	3SK131V12T1
025	XT0095	Transistor	2SC4081T106R
026	XT0095	Transistor	2SC4081T106R
027	XU0148	Transistor	DTC144EUT106
028	XT0095	Transistor	2SC4081T106R

## MAIN Unit

Ref. No.	Parts No.	Description	Parts Name
029	XU0148	Transistor	DTC144EUT106
030	XT0094	Transistor	2SA1576T106R
031	XT0095	Transistor	2SC4081T106R
032	XU0061	Transistor	UN5211-TX
033	XT0136	Transistor	2SD1664
034	XU0061	Transistor	UN5211-TX
035	XT0136	Transistor	2SD1664
036	XU0148	Transistor	DTC144EUT106
037	XT0095	Transistor	2SC4081T106R
038	XU0148	Transistor	DTC144EUT106
039	XT0095	Transistor	2SC4081T106R
040	XU0051	Transistor	UN511F-TX
041	XU0049	Transistor	UMA9TR
042	XU0049	Transistor	UMA9TR
043	XU0049	Transistor	UMA9TR
044	XU0049	Transistor	UMA9TR
045	XU0047	Transistor	UMC3TR
046	XU0061	Transistor	UN5211-TX
047	XT0095	Transistor	2SC4081T106R
048	XU0148	Transistor	DTC144EUT106
049	XT0094	Transistor	2SA1576T106R
050	XT0095	Transistor	2SC4081T106R
051	XT0127	Transistor	2SC3419-Y
052	XU0061	Transistor	UN5211-TX
053	XU0061	Transistor	UN5211-TX
054	XT0095	Transistor	2SC4081T106R
055	XU0148	Transistor	DTC144EUT106
056	XT0111	Transistor	2SC4081LNT106S
057	XU0116	Transistor	DTA123EUT106
058	XU0112	Transistor	DTA114YUT106
059	XU0112	Transistor	DTA114YUT106
060	XT0095	Transistor	2SC4081T106R
061	XU0047	Transistor	UMC3TR
062	XU0061	Transistor	UN5211-TX
063	XU0148	Transistor	DTC144EUT106
064	XT0029	Transistor	DTC114YUT106
065	XU0148	Transistor	DTC144EUT106
066	XU0061	Transistor	UN5211-TX
R1	RK3026	Chip R.	ERJ3GSYJ101V
R2	RK3013	Chip R.	ERJ3GSYJ8R2V
R3	RK3038	Chip R.	ERJ3GSYJ102V
R4	RK3042	Chip R.	ERJ3GSYJ222V
R5	RK3032	Chip R.	ERJ3GSYJ331V
R7	RK3038	Chip R.	ERJ3GSYJ102V
R8	RK3037	Chip R.	ERJ3GSYJ821V
R9	RK3030	Chip R.	ERJ3GSYJ221V

Ref. No.	Parts No.	Description	Parts Name
R10	RK3034	Chip R.	ERJ3G5YJ471V
R11	RK3035	Chip R.	ERJ3G5YJ561V
R12	RK3042	Chip R.	ERJ3G5YJ222V
R13	RK3018	Chip R.	ERJ3G5YJ220V
R14	RK3030	Chip R.	ERJ3G5YJ221V
R15	RK3049	Chip R.	ERJ3G5YJ822V
R16	RK3043	Chip R.	ERJ3G5YJ272V
R17	RK3038	Chip R.	ERJ3G5YJ102V
R18	RK3040	Chip R.	ERJ3G5YJ152V
R19	RK3050	Chip R.	ERJ3G5YJ103V
R20	RK3026	Chip R.	ERJ3G5YJ101V
R21	RK3034	Chip R.	ERJ3G5YJ471V
R22	RK3030	Chip R.	ERJ3G5YJ221V
R23	RK3026	Chip R.	ERJ3G5YJ101V
R25	RK3042	Chip R.	ERJ3G5YJ222V
R26	RK3046	Chip R.	ERJ3G5YJ472V
R28	RK3038	Chip R.	ERJ3G5YJ102V
R29	RK3038	Chip R.	ERJ3G5YJ102V
R30	RK3026	Chip R.	ERJ3G5YJ101V
R31	RK3034	Chip R.	ERJ3G5YJ471V
R32	RK3066	Chip R.	ERJ3G5YJ224V
R33	RK3026	Chip R.	ERJ3G5YJ101V
R34	RK3058	Chip R.	ERJ3G5YJ473V
R35	RK3050	Chip R.	ERJ3G5YJ103V
R36	RK3030	Chip R.	ERJ3G5YJ221V
R37	RK3023	Chip R.	ERJ3G5YJ560V
R38	RK1025	Chip R.	ERJ8G6YJ331V
R57	RK3031	Chip R.	ERJ3G5YJ271V
R58	RK3018	Chip R.	ERJ3G5YJ220V
R59	RK3024	Chip R.	ERJ3G5YJ680V
R60	RK4068	Chip R.	ERJ14YJ151H
R61	RK3050	Chip R.	ERJ3G5YJ103V
R62	RK4088	Chip R.	ERJ14YJ561H
R63	RK3035	Chip R.	ERJ3G5YJ561V
R64	RK3034	Chip R.	ERJ3G5YJ471V
R65	RK3022	Chip R.	ERJ3G5YJ470V
R66	RK3054	Chip R.	ERJ3G5YJ223V
R67	RK3074	Chip R.	ERJ3G5YJ105V
R68	RK3026	Chip R.	ERJ3G5YJ101V
R69	RK3034	Chip R.	ERJ3G5YJ471V
R70	RK3043	Chip R.	ERJ3G5YJ272V
R71	RK3026	Chip R.	ERJ3G5YJ101V
R72	RK3044	Chip R.	ERJ3G5YJ332V
R73	RK3032	Chip R.	ERJ3G5YJ331V
R74	RK3044	Chip R.	ERJ3G5YJ332V
R75	RK3038	Chip R.	ERJ3G5YJ102V

Ref. No.	Parts No.	Description	Parts Name
R76	RK3013	Chip R.	ERJ3G5YJ82V
R77	RK3020	Chip R.	ERJ3G5YJ330V
R78	RK3040	Chip R.	ERJ3G5YJ152V
R79	RK3022	Chip R.	ERJ3G5YJ470V
R80	RK3030	Chip R.	ERJ3G5YJ221V
R81	RK3058	Chip R.	ERJ3G5YJ473V
R82	RK3052	Chip R.	ERJ3G5YJ153V
R83	RK3038	Chip R.	ERJ3G5YJ102V
R84	RK3032	Chip R.	ERJ3G5YJ331V
R85	RK3050	Chip R.	ERJ3G5YJ103V
R86	RK3026	Chip R.	ERJ3G5YJ101V
R87	RK3042	Chip R.	ERJ3G5YJ222V
R88	RK3050	Chip R.	ERJ3G5YJ103V
R90	RK3042	Chip R.	ERJ3G5YJ222V
R89	RK3062	Chip R.	ERJ3G5YJ104V
R91	RK3054	Chip R.	ERJ3G5YJ223V
R92	RK3026	Chip R.	ERJ3G5YJ101V
R93	RK3022	Chip R.	ERJ3G5YJ470V
R94	RK3034	Chip R.	ERJ3G5YJ471V
R95	RK3078	Chip R.	ERJ3G5YJ225V
R96	RK3043	Chip R.	ERJ3G5YJ272V
R97	RK3058	Chip R.	ERJ3G5YJ473V
R98	RK3038	Chip R.	ERJ3G5YJ102V
R99	RK3042	Chip R.	ERJ3G5YJ222V
R100	RK3070	Chip R.	ERJ3G5YJ474V
R101	RK3026	Chip R.	ERJ3G5YJ101V
R102	RK3034	Chip R.	ERJ3G5YJ471V
R103	RK3050	Chip R.	ERJ3G5YJ103V
R104	RK3026	Chip R.	ERJ3G5YJ101V
R105	RK3050	Chip R.	ERJ3G5YJ103V
R106	RK3051	Chip R.	ERJ3G5YJ123V
R107	RK3034	Chip R.	ERJ3G5YJ471V
R108	RK3046	Chip R.	ERJ3G5YJ472V
R109	RK3046	Chip R.	ERJ3G5YJ472V
R110	RK3045	Chip R.	ERJ3G5YJ392V
R111	RK3050	Chip R.	ERJ3G5YJ103V
R112	RK3030	Chip R.	ERJ3G5YJ221V
R113	RK3030	Chip R.	ERJ3G5YJ221V
R114	RK3030	Chip R.	ERJ3G5YJ221V
R115	RK3042	Chip R.	ERJ3G5YJ222V
R116	RK3046	Chip R.	ERJ3G5YJ472V
R117	RK3046	Chip R.	ERJ3G5YJ472V
R118	RK3046	Chip R.	ERJ3G5YJ472V
R119	RK3030	Chip R.	ERJ3G5YJ221V
R120	RK3030	Chip R.	ERJ3G5YJ221V
R121	RK3030	Chip R.	ERJ3G5YJ221V

Ref. No.	Parts No.	Description	Parts Name
R122	RK3051	Chip R.	ERJ3G5YJ123V
R123	RK3050	Chip R.	ERJ3G5YJ103V
R124	RK3050	Chip R.	ERJ3G5YJ103V
R125	RK3058	Chip R.	ERJ3G5YJ473V
R126	RK3026	Chip R.	ERJ3G5YJ101V
R127	RK3026	Chip R.	ERJ3G5YJ101V
R128	RK3034	Chip R.	ERJ3G5YJ471V
R130	RK3050	Chip R.	ERJ3G5YJ103V
R131	RK3026	Chip R.	ERJ3G5YJ101V
R132	RK3054	Chip R.	ERJ3G5YJ223V
R133	RK3026	Chip R.	ERJ3G5YJ101V
R134	RK3058	Chip R.	ERJ3G5YJ473V
R135	RK3059	Chip R.	ERJ3G5YJ563V
R136	RK3042	Chip R.	ERJ3G5YJ222V
R137	RK3042	Chip R.	ERJ3G5YJ222V
R138	RK3032	Chip R.	ERJ3G5YJ331V
R139	RK3070	Chip R.	ERJ3G5YJ474V
R140	RK3047	Chip R.	ERJ3G5YJ562V
R141	RK3062	Chip R.	ERJ3G5YJ104V
R142	RK3038	Chip R.	ERJ3G5YJ102V
R143	RK3042	Chip R.	ERJ3G5YJ222V
R144	RK3026	Chip R.	ERJ3G5YJ101V
R145	RK3058	Chip R.	ERJ3G5YJ473V
R146	RK3074	Chip R.	ERJ3G5YJ105V
R147	RK3038	Chip R.	ERJ3G5YJ102V
R148	RK3038	Chip R.	ERJ3G5YJ102V
R149	RK3045	Chip R.	ERJ3G5YJ392V
R150	RK3026	Chip R.	ERJ3G5YJ101V
R151	RK3050	Chip R.	ERJ3G5YJ103V
R152	RK3048	Chip R.	ERJ3G5YJ682V
R153	RK3052	Chip R.	ERJ3G5YJ153V
R154	RK3044	Chip R.	ERJ3G5YJ332V
R155	RK3068	Chip R.	ERJ3G5YJ334V
R156	RK3050	Chip R.	ERJ3G5YJ103V
R157	RK3058	Chip R.	ERJ3G5YJ473V
R158	RK3051	Chip R.	ERJ3G5YJ123V
R159	RK3058	Chip R.	ERJ3G5YJ473V
R160	RK3050	Chip R.	ERJ3G5YJ103V
R161	RK3058	Chip R.	ERJ3G5YJ473V
R162	RK3030	Chip R.	ERJ3G5YJ221V
R163	RK3050	Chip R.	ERJ3G5YJ103V
R164	RK3062	Chip R.	ERJ3G5YJ104V
R165	RK3046	Chip R.	ERJ3G5YJ472V
R166	RK3050	Chip R.	ERJ3G5YJ103V
R167	RK3034	Chip R.	ERJ3G5YJ471V
R168	RK3076	Chip R.	ERJ3G5YJ155V

Ref. No.	Parts No.	Description	Parts Name
R169	RK3062	Chip R.	ERJ3G5YJ104V
R170	RK3058	Chip R.	ERJ3G5YJ473V
R171	RK3038	Chip R.	ERJ3G5YJ102V
R172	RK3050	Chip R.	ERJ3G5YJ103V
R173	RK3058	Chip R.	ERJ3G5YJ473V
R174	RK3001	Chip R.	ERJ3G5YR00V
R175	RK3044	Chip R.	ERJ3G5YJ332V
R176	RK3048	Chip R.	ERJ3G5YJ682V
R177	RK3044	Chip R.	ERJ3G5YJ332V
R178	RK3058	Chip R.	ERJ3G5YJ473V
R179	RK3050	Chip R.	ERJ3G5YJ103V
R180	RK3049	Chip R.	ERJ3G5YJ822V
R181	RK3026	Chip R.	ERJ3G5YJ101V
R182	RK3054	Chip R.	ERJ3G5YJ223V
R183	RK3050	Chip R.	ERJ3G5YJ103V
R184	RK3050	Chip R.	ERJ3G5YJ103V
R185	RK3050	Chip R.	ERJ3G5YJ103V
R186	RK3058	Chip R.	ERJ3G5YJ473V
R187	RK3050	Chip R.	ERJ3G5YJ103V
R188	RK3060	Chip R.	ERJ3G5YJ683V
R189	RK3062	Chip R.	ERJ3G5YJ104V
R190	RK3062	Chip R.	ERJ3G5YJ104V
R191	RK3059	Chip R.	ERJ3G5YJ563V
R192	RK3058	Chip R.	ERJ3G5YJ473V
R193	RK3058	Chip R.	ERJ3G5YJ473V
R194	RK3056	Chip R.	ERJ3G5YJ333V
R195	RK3064	Chip R.	ERJ3G5YJ154V
R196	RK3054	Chip R.	ERJ3G5YJ223V
R197	RK3056	Chip R.	ERJ3G5YJ333V
R198	RK3074	Chip R.	ERJ3G5YJ105V
R199	RK3058	Chip R.	ERJ3G5YJ473V
R200	RK3068	Chip R.	ERJ3G5YJ334V
R201	RK3067	Chip R.	ERJ3G5YJ274V
R202	RK3068	Chip R.	ERJ3G5YJ334V
R203	RK3042	Chip R.	ERJ3G5YJ222V
R204	RK3074	Chip R.	ERJ3G5YJ105V
R205	RK3034	Chip R.	ERJ3G5YJ471V
R206	RK3051	Chip R.	ERJ3G5YJ123V
R209	RK3032	Chip R.	ERJ3G5YJ331V
R212	RK3045	Chip R.	ERJ3G5YJ392V
R213	RK3046	Chip R.	ERJ3G5YJ472V
R214	RK3049	Chip R.	ERJ3G5YJ822V
R215	RK3074	Chip R.	ERJ3G5YJ105V
R216	RK3074	Chip R.	ERJ3G5YJ105V
R217	RK3062	Chip R.	ERJ3G5YJ104V
R218	RK3075	Chip R.	ERJ3G5YJ125V



Ref. No.	Parts No.	Description	Parts Name
R219	RK3074	Chip R.	ERJ3G5YJ105V
R220	RK3074	Chip R.	ERJ3G5YJ105V
R221	RK3070	Chip R.	ERJ3G5YJ474V
R222	RK3047	Chip R.	ERJ3G5YJ562V
R223	RK3034	Chip R.	ERJ3G5YJ471V
R224	RK3050	Chip R.	ERJ3G5YJ103V
R225	RK3030	Chip R.	ERJ3G5YJ221V
R226	RK3049	Chip R.	ERJ3G5YJ822V
R227	RK3070	Chip R.	ERJ3G5YJ474V
R228	RK3070	Chip R.	ERJ3G5YJ474V
R229	RK4082	Chip R.	ERJ14YK4R7H
R230	RK1035	Chip R.	ERJ8GEYJ102V
R231	RK4082	Chip R.	ERJ14YK4R7H
R232	RK1035	Chip R.	ERJ8GEYJ102V
R233	RK3054	Chip R.	ERJ3G5YJ223V
R234	RK3058	Chip R.	ERJ3G5YJ473V
R235	RK3050	Chip R.	ERJ3G5YJ103V
R236	RK3001	Chip R.	ERJ3G5YR000V
R237	RK3057	Chip R.	ERJ3G5YJ393V
R238	RK3057	Chip R.	ERJ3G5YJ393V
R239	RK3062	Chip R.	ERJ3G5YJ104V
R240	RK3042	Chip R.	ERJ3G5YJ222V
R241	RK3053	Chip R.	ERJ3G5YJ183V
R242	RK3060	Chip R.	ERJ3G5YJ683V
R243	RK3050	Chip R.	ERJ3G5YJ103V
R244	RK3062	Chip R.	ERJ3G5YJ104V
R245	RK3060	Chip R.	ERJ3G5YJ683V
R246	RK3056	Chip R.	ERJ3G5YJ333V
R247	RK3056	Chip R.	ERJ3G5YJ333V
R248	RK3054	Chip R.	ERJ3G5YJ223V
R249	RK3062	Chip R.	ERJ3G5YJ104V
R250	RK3050	Chip R.	ERJ3G5YJ103V
R251	RK3046	Chip R.	ERJ3G5YJ472V
R252	RK3062	Chip R.	ERJ3G5YJ104V
R253	RK3050	Chip R.	ERJ3G5YJ103V
R254	RK3026	Chip R.	ERJ3G5YJ101V
R255	RK3069	Chip R.	ERJ3G5YJ394V
R256	RK3071	Chip R.	ERJ3G5YJ564V
R257	RK3074	Chip R.	ERJ3G5YJ105V
R258	RK3041	Chip R.	ERJ3G5YJ182V
R259	RK3052	Chip R.	ERJ3G5YJ153V
R260	RK3060	Chip R.	ERJ3G5YJ683V
R261	RK3051	Chip R.	ERJ3G5YJ123V
R262	RK3038	Chip R.	ERJ3G5YJ102V
R263	RK3034	Chip R.	ERJ3G5YJ471V
R264	RK3034	Chip R.	ERJ3G5YJ471V

Ref. No.	Parts No.	Description	Parts Name
R265	RK3058	Chip R.	ERJ3G5YJ473V
R266	RK3034	Chip R.	ERJ3G5YJ471V
R267	RK3053	Chip R.	ERJ3G5YJ183V
R268	RK3034	Chip R.	ERJ3G5YJ471V
R269	RK3058	Chip R.	ERJ3G5YJ473V
R270	RK3054	Chip R.	ERJ3G5YJ223V
R271	RK3074	Chip R.	ERJ3G5YJ105V
R272	RK3050	Chip R.	ERJ3G5YJ103V
R273	RK3054	Chip R.	ERJ3G5YJ223V
R274	RK3070	Chip R.	ERJ3G5YJ474V
R275	RK3062	Chip R.	ERJ3G5YJ104V
R276	RK3070	Chip R.	ERJ3G5YJ474V
R277	RK3058	Chip R.	ERJ3G5YJ473V
R278	RK3058	Chip R.	ERJ3G5YJ473V
R279	RK3058	Chip R.	ERJ3G5YJ473V
R280	RK3080	Chip R.	ERJ3G5YJ335V
R281	RK3080	Chip R.	ERJ3G5YJ335V
R282	RK3074	Chip R.	ERJ3G5YJ105V
R283	RK3067	Chip R.	ERJ3G5YJ274V
R284	RK3050	Chip R.	ERJ3G5YJ103V
R285	RK3042	Chip R.	ERJ3G5YJ222V
R286	RK3074	Chip R.	ERJ3G5YJ105V
R287	RK3035	Chip R.	ERJ3G5YJ561V
R288	RK3048	Chip R.	ERJ3G5YJ682V
R289	RK3050	Chip R.	ERJ3G5YJ103V
R290	RK3026	Chip R.	ERJ3G5YJ101V
R291	RK3038	Chip R.	ERJ3G5YJ102V
R292	RK3058	Chip R.	ERJ3G5YJ473V
R293	RK3054	Chip R.	ERJ3G5YJ223V
R294	RK3045	Chip R.	ERJ3G5YJ392V
R295	RK3030	Chip R.	ERJ3G5YJ221V
R296	RK3050	Chip R.	ERJ3G5YJ103V
R297	RK3050	Chip R.	ERJ3G5YJ103V
R298	RK3050	Chip R.	ERJ3G5YJ103V
R299	RK3057	Chip R.	ERJ3G5YJ393V
R300	RK3058	Chip R.	ERJ3G5YJ473V
R301	RK3050	Chip R.	ERJ3G5YJ103V
R302	RK3045	Chip R.	ERJ3G5YJ392V
R303	RK3070	Chip R.	ERJ3G5YJ474V
R304	RK0022	Chip R.	ERJ6GEYJ221V
R305	RK0022	Chip R.	ERJ6GEYJ221V
R306	RK0114	Chip R.	ERJ6GEYJ010V
R307	RK3026	Chip R.	ERJ3G5YJ101V
R308	RK3001	Chip R.	ERJ3G5YR000V
R309	RK3048	Chip R.	ERJ3G5YJ682V
R310	RK3032	Chip R.	ERJ3G5YJ331V

Ref. No.	Parts No.	Description	Parts Name
R311	RK3074	Chip R.	ERJ3G5YJ105V
R312	RK3050	Chip R.	ERJ3G5YJ103V
R313	RK3050	Chip R.	ERJ3G5YJ103V
R314	RK3058	Chip R.	ERJ3G5YJ473V
R315	RK3058	Chip R.	ERJ3G5YJ473V
R316	RK3058	Chip R.	ERJ3G5YJ473V
R317	RK3038	Chip R.	ERJ3G5YJ102V
R318	RK3046	Chip R.	ERJ3G5YJ472V
R319	RK3054	Chip R.	ERJ3G5YJ223V
R320	RK3038	Chip R.	ERJ3G5YJ102V
R321	RK3057	Chip R.	ERJ3G5YJ393V
R322	RK3057	Chip R.	ERJ3G5YJ393V
R323	RK3056	Chip R.	ERJ3G5YJ333V
R324	RK3038	Chip R.	ERJ3G5YJ102V
R325	RK3050	Chip R.	ERJ3G5YJ103V
R326	RK3050	Chip R.	ERJ3G5YJ103V
R327	RK3064	Chip R.	ERJ3G5YJ154V
R328	RK3072	Chip R.	ERJ3G5YJ684V
R329	RK3062	Chip R.	ERJ3G5YJ104V
R330	RK3042	Chip R.	ERJ3G5YJ222V
R331	RK3062	Chip R.	ERJ3G5YJ104V
R332	RK3054	Chip R.	ERJ3G5YJ223V
R333	RK3055	Chip R.	ERJ3G5YJ273V
R334	RK3038	Chip R.	ERJ3G5YJ102V
R335	RK3026	Chip R.	ERJ3G5YJ101V
R336	RK3066	Chip R.	ERJ3G5YJ224V
R337	RK3038	Chip R.	ERJ3G5YJ102V
R338	RK3026	Chip R.	ERJ3G5YJ101V
R339	RK3042	Chip R.	ERJ3G5YJ222V
R340	RK3042	Chip R.	ERJ3G5YJ222V
R341	RK3034	Chip R.	ERJ3G5YJ471V
R342	RK3034	Chip R.	ERJ3G5YJ471V
R343	RK3050	Chip R.	ERJ3G5YJ103V
R344	RK1035	Chip R.	ERJ8GEYJ102V
R345	RK3034	Chip R.	ERJ3G5YJ471V
R346	RK3034	Chip R.	ERJ3G5YJ471V
R347	RK3034	Chip R.	ERJ3G5YJ471V
R348	RK3050	Chip R.	ERJ3G5YJ103V
R349	RK5046	Chip R.	ERJ3G5YJ472V
R350	RK3050	Chip R.	ERJ3G5YJ103V
R351	RK3033	Chip R.	ERJ3G5YJ391V
R352	RK3015	Chip R.	ERJ3G5YJ120V
R353	RK3024	Chip R.	ERJ3G5YJ680V
R354	RK3033	Chip R.	ERJ3G5YJ391V
R355	RK3064	Chip R.	ERJ3G5YJ154V
R356	RK3046	Chip R.	ERJ3G5YJ472V

Ref. No.	Parts No.	Description	Parts Name
R357	RK3030	Chip R.	ERJ3G5YJ221V
R358	RK3045	Chip R.	ERJ3G5YJ392V
R359	RK3030	Chip R.	ERJ3G5YJ221V
R360	RK3066	Chip R.	ERJ3G5YJ224V
R361	RK0020	Chip R.	ERJ6GEYJ151V
R362	RK3018	Chip R.	ERJ3G5YJ220V
R363	RK3018	Chip R.	ERJ3G5YJ220V
R364	RK3048	Chip R.	ERJ3G5YJ682V
R365	RK3042	Chip R.	ERJ3G5YJ222V
R366	RK3042	Chip R.	ERJ3G5YJ222V
R367	RK3040	Chip R.	ERJ3G5YJ152V
R368	RK3001	Chip R.	ERJ3G5YR000V
R369	RK3050	Chip R.	ERJ3G5YJ103V
R370	RK3050	Chip R.	ERJ3G5YJ103V
R371	RK3050	Chip R.	ERJ3G5YJ103V
R372	RK3050	Chip R.	ERJ3G5YJ103V
R373	RK3050	Chip R.	ERJ3G5YJ103V
R374	RK3050	Chip R.	ERJ3G5YJ103V
R375	RK3050	Chip R.	ERJ3G5YJ103V
R376	RK3050	Chip R.	ERJ3G5YJ103V
R377	RK3064	Chip R.	ERJ3G5YJ154V
R378	RK3050	Chip R.	ERJ3G5YJ103V
R379	RK3050	Chip R.	ERJ3G5YJ103V
R380	RK3050	Chip R.	ERJ3G5YJ103V
R381	RK3058	Chip R.	ERJ3G5YJ473V
R382	RK3050	Chip R.	ERJ3G5YJ103V
R383	RK3053	Chip R.	ERJ3G5YJ183V
R384	RK3054	Chip R.	ERJ3G5YJ223V
R385	RK3047	Chip R.	ERJ3G5YJ562V
R386	RK3026	Chip R.	ERJ3G5YJ101V
R388	RK3034	Chip R.	ERJ3G5YJ471V
R389	RK3034	Chip R.	ERJ3G5YJ471V
R390	RK3053	Chip R.	ERJ3G5YJ183V
R391	RK3064	Chip R.	ERJ3G5YJ154V
R392	RK3050	Chip R.	ERJ3G5YJ103V
R393	RK3042	Chip R.	ERJ3G5YJ222V
R394	RK3058	Chip R.	ERJ3G5YJ473V
R395	RK3066	Chip R.	ERJ3G5YJ224V
R396	RK3042	Chip R.	ERJ3G5YJ222V
R397	RK1023	Chip R.	ERJ8GEYJ271V
R398	RK3054	Chip R.	ERJ3G5YJ223V
R399	RK3054	Chip R.	ERJ3G5YJ223V
R400	RK3054	Chip R.	ERJ3G5YJ223V
R401	RK3054	Chip R.	ERJ3G5YJ223V
R402	RK3054	Chip R.	ERJ3G5YJ223V
R404	RK3062	Chip R.	ERJ3G5YJ104V

Ref. No.	Parts No.	Description	Parts Name
R405	RK3049	Chip R.	ERJ3GSYJ822V
R406	RK3049	Chip R.	ERJ3GSYJ822V
R407	RK3046	Chip R.	ERJ3GSYJ472V
R408	RK3054	Chip R.	ERJ3GSYJ223V
R409	RK3014	Chip R.	ERJ3GSYJ100V
R411	RK3027	Chip R.	ERJ3GSYJ121V
S1	US0012	Switch	SSSS212A NS L=2
TH1	XS0019	Thermistor	TBPS1R472K440H50
TH2	XS0017	Thermistor	TBPS1R222K410H50
VR1	RHO115	Trim Pot	EVMIYSX50B12
VR2	RHO101	Trim Pot	EVMIYSX50B03
VR3	RHO103	Trim Pot	EVMIYSX50B14
VR4	RHO103	Trim Pot	EVMIYSX50B14
VR5	RHO111	Trim Pot	EVMIYSX50B05
VR6	RHO103	Trim Pot	EVMIYSX50B14
VR7	RHO108	Trim Pot	EVMIYSX50B15
VR8	RHO111	Trim Pot	EVMIYSX50B05
VR9	RHO108	Trim Pot	EVMIYSX50B15
VR10	RHO099	Trim Pot	EVMIYSX50B3
VR11	RHO099	Trim Pot	EVMIYSX50B3
VR12	RHO099	Trim Pot	EVMIYSX50B3
VR13	RHO103	Trim Pot	EVMIYSX50B14
VR14	RHO103	Trim Pot	EVMIYSX50B14
VR15	RHO113	Trim Pot	EVMIYSX50B16
X1	XK0001	Filter	CDB455C7
TZ0049	UM-1		
TZ0049	UM-1		
TZ0049	UM-1		
JP0288		P.C.B	Circuit Board B

Ref. No.	Parts No.	Description	Parts Name
<b>BPF1 Unit</b>			
C54	CU3059	Chip C.	C1608JF1E1042T-A
C55	CU3023	Chip C.	C1608CH1H101JT-A
C56	CU3035	Chip C.	C1608JB1H102KT-A
C57	CU3035	Chip C.	C1608JB1H102KT-A
C58	CU3059	Chip C.	C1608JF1E1042T-A
C73	CU3025	Chip C.	C1608CH1H151JT-A
C74	CU3034	Chip C.	C1608JB1H821KT-A
C75	CU3034	Chip C.	C1608JB1H821KT-A
C76	CU3056	Chip C.	C1608JF1E4732T-A
C77	CU3056	Chip C.	C1608JF1E4732T-A
D12	XD0266	Diode	DAP236U T106
D13	XD0272	Diode	1SS356 TW11
L22	QC0079	Chip L.	NL322522T-270J
L23	QC0078	Chip L.	NL322522T-220J
L33	QC0043	Chip L.	NL322522T-2R2J
L34	QC0129	Chip L.	NL322522T-R39J-3
L35	QC0129	Chip L.	NL322522T-R39J-3
R39	RK4070	Chip R.	ERJ14YJ271H
R40	RK3015	Chip R.	ERJ3GSYJ120V
R41	RK3031	Chip R.	ERJ3GSYJ271V
R47	RK3028	Chip R.	ERJ3GSYJ151V
R48	RK4068	Chip R.	ERJ14YJ151H
<b>BPF2 Unit</b>			
C59	CU3040	Chip C.	C1608JB1H272KT-A
C60	CU3042	Chip C.	C1608JB1H392KT-A
C61	CU3040	Chip C.	C1608JB1H272KT-A
C62	CU3056	Chip C.	C1608JF1E4732T-A
C78	CU3024	Chip C.	C1608CH1H121JT-A
C79	CU3033	Chip C.	C1608JB1H681KT-A
C80	CU3033	Chip C.	C1608JB1H681KT-A
C81	CU3056	Chip C.	C1608JF1E4732T-A
C82	CU3056	Chip C.	C1608JF1E4732T-A
D14	XD0266	Diode	DAP236U T106
D15	XD0266	Diode	DAP236U T106
L24	QC0045	Chip L.	NL322522T-3R3J
L25	QC0045	Chip L.	NL322522T-3R3J
L26	QC0497	Chip L.	LOH4N102J04
L36	QC0041	Chip L.	NL322522T-1R5J
L37	QC0127	Chip L.	NL322522T-R27J-3
L38	QC0127	Chip L.	NL322522T-R27J-3
R42	RK4069	Chip R.	ERJ14YJ221H
R49	RK3028	Chip R.	ERJ3GSYJ151V
R50	RK4068	Chip R.	ERJ14YJ151H

Ref. No.	Parts No.	Description	Parts Name
<b>BPF3 Unit</b>			
C63	CU3034	Chip C.	C1608JB1H821KT-A
C64	CU3037	Chip C.	C1608JB1H152KT-A
C65	CU3037	Chip C.	C1608JB1H152KT-A
C66	CU3056	Chip C.	C1608JF1E4732T-A
C67	CU3056	Chip C.	C1608JF1E4732T-A
C83	CU3022	Chip C.	C1608CH1H820JT-A
C84	CU3030	Chip C.	C1608JB1H391KT-A
C85	CU3030	Chip C.	C1608JB1H391KT-A
C86	CU3056	Chip C.	C1608JF1E4732T-A
C87	CU3056	Chip C.	C1608JF1E4732T-A
D16	XD0266	Diode	DAP236U T106
D17	XD0266	Diode	DAP236U T106
L27	QC0046	Chip L.	NL322522T-3R9J
L28	QC0043	Chip L.	NL322522T-2R2J
L29	QC0043	Chip L.	NL322522T-2R2J
L39	QC0039	Chip L.	NL322522T-1R0J
L40	QC0126	Chip L.	NL322522T-R22J-3
L41	QC0126	Chip L.	NL322522T-R22J-3
R43	RK3028	Chip R.	ERJ3GSYJ151V
R44	RK4068	Chip R.	ERJ14YJ151H
R51	RK3028	Chip R.	ERJ3GSYJ151V
R52	RK4068	Chip R.	ERJ14YJ151H
<b>BPF4 Unit</b>			
C68	CU3030	Chip C.	C1608JB1H391KT-A
C69	CU3034	Chip C.	C1608JB1H821KT-A
C70	CU3034	Chip C.	C1608JB1H821KT-A
C71	CU3056	Chip C.	C1608JF1E4732T-A
C72	CU3056	Chip C.	C1608JF1E4732T-A
C88	CU3092	Chip C.	C1608CH1H510JT-A
C89	CU3029	Chip C.	C1608JB1H331KT-A
C90	CU3029	Chip C.	C1608JB1H331KT-A
C91	CU3056	Chip C.	C1608JF1E4732T-A
C92	CU3056	Chip C.	C1608JF1E4732T-A
D18	XD0266	Diode	DAP236U T106
D19	XD0266	Diode	DAP236U T106
L30	QC0043	Chip L.	NL322522T-2R2J
L31	QC0039	Chip L.	NL322522T-1R0J
L32	QC0039	Chip L.	NL322522T-1R0J
L42	QC0133	Chip L.	NL322522T-R82J-3
L43	QC0123	Chip L.	NL322522T-R12J-3
L44	QC0123	Chip L.	NL322522T-R12J-3
R45	RK3028	Chip R.	ERJ3GSYJ151V
R46	RK4068	Chip R.	ERJ14YJ151H
R53	RK3028	Chip R.	ERJ3GSYJ151V

Ref. No.	Parts No.	Description	Parts Name
R54	RK4068	Chip R.	ERJ14YJ151H
<b>BPF5 Unit</b>			
C93	CU3013	Chip C.	C1608CH1H150JT-A
C94	CU3026	Chip C.	C1608CH1H181JT-A
C95	CU3026	Chip C.	C1608CH1H181JT-A
C96	CU3047	Chip C.	C1608JB1H103KT-A
C97	CU3047	Chip C.	C1608JB1H103KT-A
D27	XD0272	Diode	1SS356 TW11
D28	XD0272	Diode	1SS356 TW11
L45	QC0131	Chip L.	NL322522T-R56J-3
L46	QC0063	Chip L.	NL322522T-047J
L47	QC0063	Chip L.	NL322522T-047J
R55	RK3030	Chip R.	ERJ3GSYJ221V
R56	RK4069	Chip R.	ERJ14YJ221H
<b>Connector Unit</b>			
CN7	UE0266	Connector	S12B-EH
CN8	UE0254	Connector	S13B-ZR
CN14	UE0263	Connector	1MSA-9120S-13
CN15	UE0263	Connector	1MSA-9120S-13
<b>Mic Unit</b>			
CN10	UE0261	Connector	09R-JE
J6	UE0035	Connector	MIC FM214-8SPMY
L78	QC0086	Chip L.	NL322522T-101J
L79	QC0086	Chip L.	NL322522T-101J
<b>PLL Unit</b>			
C701	CU3017	Chip C.	C1608CH1H330JT-A
C702	CU3022	Chip C.	C1608CH1H820JT-A
C703	CU3047	Chip C.	C1608JB1H103KT-A
C704	CU3047	Chip C.	C1608JB1H103KT-A
C705	CU3013	Chip C.	C1608CH1H150JT-A
C706	CU3035	Chip C.	C1608JB1H102KT-A
C707	CU3035	Chip C.	C1608JB1H102KT-A
C708	CU3035	Chip C.	C1608JB1H102KT-A
C709	CU3035	Chip C.	C1608JB1H102KT-A
C710	CU3023	Chip C.	C1608CH1H101JT-A
C711	CS0372	ChipTantalum	TMCMB1C106MTR
C712	CU3035	Chip C.	C1608JB1H102KT-A
C713	CS0372	ChipTantalum	TMCMB1C106MTR
C714	CU3035	Chip C.	C1608JB1H102KT-A
C715	CU3035	Chip C.	C1608JB1H102KT-A
C716	CS0220	ChipTantalum	TMCM1C225MTR
C717	CS0220	ChipTantalum	TMCM1C225MTR

PLL Unit

Ref. No.	Parts No.	Description	Parts Name
C718	CU3035	Chip C.	C1608JB1H102KT-A
C719	CU8042	Chip C.	C2012JB1C104KT-A
C720	CE0374	Electrolytic C.	16CV100BS
C721	CU3101	Chip C.	C1608JB1C473KT-A
C722	CU3014	Chip C.	C1608CH1H180JT-A
C723	CU3035	Chip C.	C1608JB1H102KT-A
C724	CS0372	ChipTantalum	TMCMB1C106MTR
C725	CU3035	Chip C.	C1608JB1H102KT-A
C726	CU3035	Chip C.	C1608JB1H102KT-A
C727	CU3035	Chip C.	C1608JB1H102KT-A
C728	CU3101	Chip C.	C1608JB1C473KT-A
C729	CU3033	Chip C.	C1608JB1H681KT-A
C730	CU3019	Chip C.	C1608CH1H470JT-A
C731	CU3034	Chip C.	C1608JB1H821KT-A
C732	CU3024	Chip C.	C1608CH1H21JT-A
C733	CU3032	Chip C.	C1608JB1H561KT-A
C734	CU3101	Chip C.	C1608JB1C473KT-A
C735	CS0225	ChipTantalum	TMCSA1D155MTR
C736	CU3101	Chip C.	C1608JB1C473KT-A
C737	CU3047	Chip C.	C1608JB1H103KT-A
C738	CU3051	Chip C.	C1608JB1E223KT-A
C739	CU3035	Chip C.	C1608JB1H102KT-A
C740	CU3047	Chip C.	C1608JB1H103KT-A
C741	CU3047	Chip C.	C1608JB1H103KT-A
C742	CU3047	Chip C.	C1608JB1H103KT-A
C743	CS0061	ChipTantalum	TMCSA1V224MTR
C744	CU3047	Chip C.	C1608JB1H103KT-A
C745	CU3047	Chip C.	C1608JB1H103KT-A
C746	CU3012	Chip C.	C1608CH1H20JT-A
C747	CU3002	Chip C.	C1608CH1H010CT-A
C748	CU3002	Chip C.	C1608CH1H010CT-A
C749	CU3012	Chip C.	C1608CH1H20JT-A
C750	CU3007	Chip C.	C1608CH1H060CT-A
C751	CU3035	Chip C.	C1608JB1H102KT-A
C752	CU3035	Chip C.	C1608JB1H102KT-A
C753	CU3014	Chip C.	C1608CH1H180JT-A
C754	CU3001	Chip C.	C1608CH1H095CT-A
C755	CU3088	Chip C.	C1608CH1H200JT-A
C756	CU3035	Chip C.	C1608JB1H102KT-A
C757	CU3035	Chip C.	C1608JB1H102KT-A
C758	CU3035	Chip C.	C1608JB1H102KT-A
C759	CU3035	Chip C.	C1608JB1H102KT-A
C760	CE0310	Electrolytic C.	ECEV1AA330P
C761	CU3047	Chip C.	C1608JB1H103KT-A
C762	CU3035	Chip C.	C1608JB1H102KT-A
C763	CU3035	Chip C.	C1608JB1H102KT-A

Ref. No.	Parts No.	Description	Parts Name
C764	CU3035	Chip C.	C1608JB1H102KT-A
C765	CU3014	Chip C.	C1608CH1H180JT-A
C766	CU3035	Chip C.	C1608JB1H102KT-A
C767	CU3035	Chip C.	C1608JB1H102KT-A
C768	CE0313	Electrolytic C.	ECEV1CA220P
C769	CU3047	Chip C.	C1608JB1H103KT-A
C770	CE0313	Electrolytic C.	ECEV1CA220P
C771	CU3047	Chip C.	C1608JB1H103KT-A
C772	CU3014	Chip C.	C1608CH1H180JT-A
C773	CU3004	Chip C.	C1608CH1H030CT-A
C774	CU3035	Chip C.	C1608JB1H102KT-A
C775	CU3101	Chip C.	C1608JB1C473KT-A
C776	CU3047	Chip C.	C1608JB1H103KT-A
C777	CU3101	Chip C.	C1608JB1C473KT-A
C780	CU3046	Chip C.	C1608JB1H822KT-A
C781	CU3046	Chip C.	C1608JB1H822KT-A
C782	CU3041	Chip C.	C1608JB1H332KT-A
C783	CS0069	ChipTantalum	TMCSA1V154MTR
C784	CU3047	Chip C.	C1608JB1H103KT-A
C785	CU3051	Chip C.	C1608JB1E223KT-A
C786	CU3101	Chip C.	C1608JB1C473KT-A
C787	CU8042	Chip C.	C2012JB1C104KT-A
C788	CU3047	Chip C.	C1608JB1H103KT-A
C789	CU3047	Chip C.	C1608JB1H103KT-A
C790	CU3015	Chip C.	C1608CH1H220JT-A
C791	CU3027	Chip C.	C1608CH1H221JT-A
C792	CU3027	Chip C.	C1608CH1H221JT-A
C793	CU3035	Chip C.	C1608JB1H102KT-A
C794	CS0372	ChipTantalum	TMCMB1C106MTR
C795	CU3051	Chip C.	C1608JB1E223KT-A
C796	CS0372	ChipTantalum	TMCMB1C106MTR
C797	CU3047	Chip C.	C1608JB1H103KT-A
C798	CU8042	Chip C.	C2012JB1C104KT-A
C799	CU3047	Chip C.	C1608JB1H103KT-A
C800	CS0049	ChipTantalum	TMCSA1C105MTR
C801	CS0049	ChipTantalum	TMCSA1C105MTR
C802	CU3035	Chip C.	C1608JB1H102KT-A
C803	CU3047	Chip C.	C1608JB1H103KT-A
C804	CU3015	Chip C.	C1608CH1H220JT-A
C805	CU3025	Chip C.	C1608CH1H151KT-A
C806	CU3025	Chip C.	C1608CH1H151KT-A
C807	CU3016	Chip C.	C1608CH1H270JT-A
C808	CU3047	Chip C.	C1608JB1H103KT-A
C809	CU3021	Chip C.	C1608CH1H680JT-A
C810	CU3011	Chip C.	C1608CH1H100CT-A
C811	CU3016	Chip C.	C1608CH1H270JT-A

Ref. No.	Parts No.	Description	Parts Name
C812	CU3020	Chip C.	C1608CH1H560JT-A
C813	CU3035	Chip C.	C1608JB1H102KT-A
C814	CU3047	Chip C.	C1608JB1H103KT-A
C816	CU3035	Chip C.	C1608JB1H102KT-A
C817	CE0310	Electrolytic C.	ECEV1A330P
C818	CU3035	Chip C.	C1608JB1H102KT-A
C819	CU3035	Chip C.	C1608JB1H102KT-A
C820	CU3035	Chip C.	C1608JB1H102KT-A
C821	CU3101	Chip C.	C1608JB1C473KT-A
C823	CU3035	Chip C.	C1608JB1H102KT-A
C824	CU3051	Chip C.	C1608JB1E223KT-A
C825	CU3035	Chip C.	C1608JB1H102KT-A
C826	CU3020	Chip C.	C1608CH1H560JT-A
C827	CU3019	Chip C.	C1608CH1H470JT-A
C828	CU3024	Chip C.	C1608CH1H21JT-A
C829	CU3013	Chip C.	C1608CH1H50JT-A
C830	CU3021	Chip C.	C1608CH1H680JT-A
C831	CU3043	Chip C.	C1608JB1H472KT-A
C832	CU3043	Chip C.	C1608JB1H472KT-A
C833	CU3049	Chip C.	C1608JB1E153KT-A
C834	CU3101	Chip C.	C1608JB1C473KT-A
C835	CU3101	Chip C.	C1608JB1C473KT-A
C836	CU3101	Chip C.	C1608JB1C473KT-A
C837	CU3015	Chip C.	C1608CH1H220JT-A
C838	CU3035	Chip C.	C1608JB1H102KT-A
C840	CU3035	Chip C.	C1608JB1H102KT-A
C841	CU3035	Chip C.	C1608JB1H102KT-A
C842	CU3013	Chip C.	C1608CH1H50JT-A
C844	CU3035	Chip C.	C1608JB1H102KT-A
C845	CU3006	Chip C.	C1608CH1H050CT-A
C846	CU3020	Chip C.	C1608CH1H560JT-A
C847	CU3020	Chip C.	C1608CH1H560JT-A
C848	CU3027	Chip C.	C1608CH1H221JT-A
C849	CU3016	Chip C.	C1608CH1H270JT-A
C850	CU3014	Chip C.	C1608CH1H180JT-A
C851	CL3016	Chip C.	C1608CH1H270JT-A
C852	CL3035	Chip C.	C1608JB1H102KT-A
C853	CL3035	Chip C.	C1608JB1H102KT-A
C854	CU3022	Chip C.	C1608CH1H820JT-A
C855	CL3019	Chip C.	C1608CH1H470JT-A
C856	CU3010	Chip C.	C1608CH1H090CT-A
C857	CU3002	Chip C.	C1608CH1H010CT-A
C858	CU3011	Chip C.	C1608CH1H100CT-A
C859	CU3035	Chip C.	C1608JB1H102KT-A
C860	CU3035	Chip C.	C1608JB1H102KT-A
C861	CU3002	Chip C.	C1608CH1H010CT-A

PLL Unit

Ref. No.	Parts No.	Description	Parts Name
C862	CU3011	Chip C.	C1608CH1H100CT-A
C863	CU3011	Chip C.	C1608CH1H100CT-A
C864	CU3035	Chip C.	C1608JB1H102KT-A
C865	CU3035	Chip C.	C1608JB1H102KT-A
C866	CU3047	Chip C.	C1608JB1H103KT-A
C867	CU3047	Chip C.	C1608JB1H103KT-A
C868	CU3047	Chip C.	C1608JB1H103KT-A
C869	CU3013	Chip C.	C1608CH1H150JT-A
C870	CU3006	Chip C.	C1608CH1H050CT-A
C871	CU3047	Chip C.	C1608JB1H103KT-A
C872	CU3016	Chip C.	C1608CH1H270JT-A
C873	CU3002	Chip C.	C1608CH1H010CT-A
C874	CU3002	Chip C.	C1608CH1H010CT-A
C875	CU3016	Chip C.	C1608CH1H270JT-A
C876	CU3016	Chip C.	C1608CH1H270JT-A
C877	CU3047	Chip C.	C1608JB1H103KT-A
C878	CU3006	Chip C.	C1608CH1H050CT-A
C879	CU3047	Chip C.	C1608JB1H103KT-A
C880	CU3101	Chip C.	C1608JB1C473KT-A
CN701	UE0259	Connector	CFP0526-0201
CN702	UE0165	Connector	B4B-2F
D701	XD0254	Diode	1SS355 TE17
D702	XD0254	Diode	1SS355 TE17
D703	XD0254	Diode	1SS355 TE17
D704	XD0289	Diode	S3275 (TE12L)
D705	XD0039	Diode	RLS4152 TE-11
D706	XD0233	Diode	1SV217TPH4
D707	XD0254	Diode	1SS355 TE17
D708	XD0231	Diode	DAP202U T106
D709	XD0230	Diode	DAN202U T106
D710	XD0254	Diode	1SS355 TE17
D711	XD0230	Diode	DAN202U T106
D712	XD0230	Diode	DAN202U T106
D713	XD0254	Diode	1SS355 TE17
D714	XD0230	Diode	DAN202U T106
D715	XD0230	Diode	DAN202U T106
D716	XD0230	Diode	DAN202U T106
D717	XD0230	Diode	DAN202U T106
D718	XD0230	Diode	DAN202U T106
D719	XD0230	Diode	DAN202U T106
D720	XD0230	Diode	DAN202U T106
D721	XD0230	Diode	DAN202U T106
D722	XD0254	Diode	1SS355 TE17
D723	XD0254	Diode	1SS355 TE17
D724	XD0272	Diode	1SS356 TW11
D725	XD0257	Diode	RN711H

Ref. No.	Parts No.	Description	Parts Name
D726	XD0272	Diode	1SS356 TW11
D727	XD0254	Diode	1SS355 TE17
D728	XD0254	Diode	1SS355 TE17
D729	XD0254	Diode	1SS355 TE17
D730	XD0254	Diode	1SS355 TE17
D732	XD0254	Diode	1SS355 TE17
D733	XD0254	Diode	1SS355 TE17
D734	XD0254	Diode	1SS355 TE17
D735	XD0254	Diode	1SS355 TE17
FL701	XC0013	Ceramic Filter	SK107M3-AE-20(A)
IC701	XA0379	IC	UPC1037GR-E1 (MS)
IC702	XA0297	IC	MB87086APF-G-BND-TF
IC703	XA0298	IC	MB87014APF-G-BND-TF
IC705	XA0294	IC	MC74HC390FL2
IC706	XA0379	IC	UPC1037GR-E1 (MS)
IC707	XA0297	IC	MB87086APF-G-BND-TF
IC708	XA0346	IC	MCT7805CT
IC709	XA0379	IC	UPC1037GR-E1 (MS)
IC710	XA0305	IC	TCT4AC74F (EL)
IC711	XA0304	IC	BA4425F-E1
IC712	XA0379	IC	UPC1037GR-E1 (MS)
IC714	XA0294	IC	MC74HC390FL2
IC715	XA0115	IC	TC4966FTE85L
IC716	XA0246	IC	BU4094BF-T1
L701	QA0131	Chip L.	NL322522T-R56J-3
J701	UX1087	Wire	PLL -
L702	QA0108	Coil	QA0108
J702	UX1087	Wire	PLL -
L703	QC0085	Chip L.	NL322522T-820J
J703	UX1087	Wire	PLL -
L704	QC0084	Chip L.	NL322522T-680J
L705	QC0086	Chip L.	NL322522T-101J
L706	QA0107	Coil	QA0107
L707	QA0107	Coil	QA0107
L708	QA0107	Coil	QA0107
L709	QA0107	Coil	QA0107
L710	QA0107	Coil	QA0107
L711	QA0107	Coil	QA0107
L712	QA0107	Coil	QA0107
L713	QC0132	Chip L.	NL322522T-R68J-3
L714	QC0075	Chip L.	NL322522T-120J
L715	QC0080	Chip L.	NL322522T-330J
L716	QC0076	Chip L.	NL322522T-150J
L717	QC0074	Chip L.	NL322522T-8R2J
L718	QC0072	Chip L.	NL322522T-5R6J
L719	QC0048	Chip L.	NL322522T-100J

Ref. No.	Parts No.	Description	Parts Name
L720	QA0108	Coil	QA0108
L721	QA0108	Coil	QA0108
L722	QA0108	Coil	QA0108
L724	QC0124	Chip L.	NL322522T-R15J-3
L725	QC0126	Chip L.	NL322522T-R22J-3
L726	QC0076	Chip L.	NL322522T-150J
L727	QC0064	Chip L.	NL322522T-056J
L728	QC0123	Chip L.	NL322522T-R12J-3
L729	QR0017	Coil	QR0017
L730	QR0017	Coil	QR0017
L731	QC0130	Chip L.	NL322522T-R47J-3
L732	QA0118	Coil	QA0118
L733	QA0118	Coil	QA0118
L734	QA0118	Coil	QA0118
L735	QA0118	Coil	QA0118
L736	QC0048	Chip L.	NL322522T-100J
L737	QC0473	Chip L.	LOH4N100J04
L738	QC0064	Chip L.	NL322522T-056J
0701	XT0095	Transistor	2SC4081T106R
0702	XT0059	Transistor	2SC3082KT146Q
0703	XT0059	Transistor	2SC3082KT146Q
0704	XT0080	Transistor	2SC3324B
0705	XT0080	Transistor	2SC3324B
0706	XT0080	Transistor	2SC3324B
0707	XT0059	Transistor	2SC3082KT146Q
0708	XT0059	Transistor	2SC3082KT146Q
0709	XU0140	Transistor	DTC124EUT106
0710	XT0059	Transistor	2SC3082KT146Q
0711	XT0059	Transistor	2SC3082KT146Q
0712	XT0059	Transistor	2SC3082KT146Q
0713	XT0096	Transistor	2SC4099T106N
0714	XT0059	Transistor	2SC3082KT146Q
0715	XU0140	Transistor	DTC124EUT106
0716	XT0059	Transistor	2SC3082KT146Q
0717	XU0140	Transistor	DTC124EUT106
0718	XU0148	Transistor	DTC144EUT106
0719	XT0059	Transistor	2SC3082KT146Q
0721	XT0095	Transistor	2SC4081T106R
0722	XT0095	Transistor	2SC4081T106R
0723	XT0095	Transistor	2SC4081T106R
0724	XT0095	Transistor	2SC4081T106R
0725	XT0095	Transistor	2SC4081T106R
0726	XU0125	Transistor	DTA144EUT106
0727	XU0148	Transistor	DTC144EUT106
0728	XT0094	Transistor	2SA1576T106R
0729	XU0148	Transistor	DTC144EUT106

Ref. No.	Parts No.	Description	Parts Name
0730	XU0148	Transistor	DTC144EUT106
0731	XT0059	Transistor	2SC3082KT146Q
0732	XU0174	Transistor	UN5112
0733	XU0125	Transistor	DTA144EUT106
0734	XU0148	Transistor	DTC144EUT106
0735	XU0148	Transistor	DTC144EUT106
R701	RK3030	Chip R.	ERJ3GSYJ221V
R702	RK3052	Chip R.	ERJ3GSYJ153V
R703	RK3046	Chip R.	ERJ3GSYJ472V
R704	RK3034	Chip R.	ERJ3GSYJ471V
R705	RK3022	Chip R.	ERJ3GSYJ470V
R706	RK3054	Chip R.	ERJ3GSYJ223V
R707	RK3038	Chip R.	ERJ3GSYJ102V
R708	RK3054	Chip R.	ERJ3GSYJ223V
R709	RK3042	Chip R.	ERJ3GSYJ222V
R710	RK3022	Chip R.	ERJ3GSYJ470V
R711	RK3054	Chip R.	ERJ3GSYJ223V
R712	RK3038	Chip R.	ERJ3GSYJ102V
R713	RK3054	Chip R.	ERJ3GSYJ223V
R714	RK3042	Chip R.	ERJ3GSYJ222V
R715	RK3050	Chip R.	ERJ3GSYJ103V
R716	RK3050	Chip R.	ERJ3GSYJ103V
R717	RK3034	Chip R.	ERJ3GSYJ471V
R718	RK3034	Chip R.	ERJ3GSYJ471V
R719	RK3034	Chip R.	ERJ3GSYJ471V
R720	RK3050	Chip R.	ERJ3GSYJ103V
R721	RK3038	Chip R.	ERJ3GSYJ102V
R722	RK3034	Chip R.	ERJ3GSYJ471V
R723	RK3034	Chip R.	ERJ3GSYJ471V
R724	RK3034	Chip R.	ERJ3GSYJ471V
R725	RK3042	Chip R.	ERJ3GSYJ222V
R726	RK3038	Chip R.	ERJ3GSYJ102V
R727	RK3038	Chip R.	ERJ3GSYJ102V
R728	RK3070	Chip R.	ERJ3GSYJ474V
R729	RK3026	Chip R.	ERJ3GSYJ101V
R730	RK3038	Chip R.	ERJ3GSYJ102V
R731	RK3046	Chip R.	ERJ3GSYJ472V
R732	RK3026	Chip R.	ERJ3GSYJ101V
R733	RK3026	Chip R.	ERJ3GSYJ101V
R734	RK3050	Chip R.	ERJ3GSYJ103V
R735	RK3058	Chip R.	ERJ3GSYJ473V
R736	RK3048	Chip R.	ERJ3GSYJ682V
R737	RK3035	Chip R.	ERJ3GSYJ561V
R739	RK3026	Chip R.	ERJ3GSYJ101V
R740	RK3030	Chip R.	ERJ3GSYJ221V
R741	RK3001	Chip R.	ERJ3GSYOR00V

Ref. No.	Parts No.	Description	Parts Name
R742	RK3038	Chip R.	ERJ3GSYJ102V
R743	RK3026	Chip R.	ERJ3GSYJ101V
R744	RK3030	Chip R.	ERJ3GSYJ221V
R745	RK3050	Chip R.	ERJ3GSYJ103V
R746	RK3041	Chip R.	ERJ3GSYJ182V
R747	RK3038	Chip R.	ERJ3GSYJ102V
R748	RK3026	Chip R.	ERJ3GSYJ101V
R749	RK3001	Chip R.	ERJ3GSYOR00V
R750	RK3022	Chip R.	ERJ3GSYJ470V
R751	RK3026	Chip R.	ERJ3GSYJ101V
R752	RK3026	Chip R.	ERJ3GSYJ101V
R753	RK3038	Chip R.	ERJ3GSYJ102V
R754	RK3054	Chip R.	ERJ3GSYJ223V
R755	RK3042	Chip R.	ERJ3GSYJ222V
R756	RK3054	Chip R.	ERJ3GSYJ223V
R757	RK3050	Chip R.	ERJ3GSYJ103V
R758	RK3034	Chip R.	ERJ3GSYJ471V
R759	RK3034	Chip R.	ERJ3GSYJ471V
R760	RK3034	Chip R.	ERJ3GSYJ471V
R761	RK3034	Chip R.	ERJ3GSYJ471V
R762	RK3026	Chip R.	ERJ3GSYJ101V
R763	RK3050	Chip R.	ERJ3GSYJ103V
R764	RK3046	Chip R.	ERJ3GSYJ472V
R765	RK3038	Chip R.	ERJ3GSYJ102V
R766	RK3066	Chip R.	ERJ3GSYJ224V
R767	RK3074	Chip R.	ERJ3GSYJ105V
R769	RK3062	Chip R.	ERJ3GSYJ104V
R770	RK3034	Chip R.	ERJ3GSYJ471V
R771	RK3034	Chip R.	ERJ3GSYJ471V
R773	RK3042	Chip R.	ERJ3GSYJ222V
R774	RK3043	Chip R.	ERJ3GSYJ272V
R775	RK3046	Chip R.	ERJ3GSYJ472V
R776	RK3026	Chip R.	ERJ3GSYJ101V
R777	RK3038	Chip R.	ERJ3GSYJ102V
R778	RK3042	Chip R.	ERJ3GSYJ222V
R779	RK3034	Chip R.	ERJ3GSYJ471V
R780	RK3042	Chip R.	ERJ3GSYJ222V
R781	RK3054	Chip R.	ERJ3GSYJ223V
R782	RK3054	Chip R.	ERJ3GSYJ223V
R783	RK3042	Chip R.	ERJ3GSYJ222V
R784	RK3054	Chip R.	ERJ3GSYJ223V
R785	RK3052	Chip R.	ERJ3GSYJ153V
R786	RK3062	Chip R.	ERJ3GSYJ104V
R787	RK3062	Chip R.	ERJ3GSYJ104V
R788	RK3046	Chip R.	ERJ3GSYJ472V
R794	RK3026	Chip R.	ERJ3GSYJ101V

PLL Unit

Ref. No.	Parts No.	Description	Parts Name
R795	RK3050	Chip R	ERJ3GSYJ103V
R796	RK3074	Chip R	ERJ3GSYJ105V
R797	RK3046	Chip R	ERJ3GSYJ472V
R798	RK3054	Chip R	ERJ3GSYJ223V
R800	RK3038	Chip R	ERJ3GSYJ102V
R801	RK3030	Chip R	ERJ3GSYJ221V
R802	RK3036	Chip R	ERJ3GSYJ681V
R803	RK3050	Chip R	ERJ3GSYJ103V
R804	RK3050	Chip R	ERJ3GSYJ103V
R805	RK3039	Chip R	ERJ3GSYJ122V
R806	RK3054	Chip R	ERJ3GSYJ223V
R807	RK3052	Chip R	ERJ3GSYJ153V
R808	RK3046	Chip R	ERJ3GSYJ472V
R809	RK3046	Chip R	ERJ3GSYJ472V
R810	RK3030	Chip R	ERJ3GSYJ221V
R811	RK3046	Chip R	ERJ3GSYJ472V
R812	RK3030	Chip R	ERJ3GSYJ221V
R813	RK3046	Chip R	ERJ3GSYJ472V
R814	RK3046	Chip R	ERJ3GSYJ472V
R815	RK3042	Chip R	ERJ3GSYJ222V
R816	RK3030	Chip R	ERJ3GSYJ221V
R817	RK3046	Chip R	ERJ3GSYJ472V
R818	RK3062	Chip R	ERJ3GSYJ104V
R819	RK3039	Chip R	ERJ3GSYJ122V
R820	RK3026	Chip R	ERJ3GSYJ101V
R821	RK3026	Chip R	ERJ3GSYJ101V
R822	RK3054	Chip R	ERJ3GSYJ223V
R823	RK3054	Chip R	ERJ3GSYJ223V
R824	RK3042	Chip R	ERJ3GSYJ222V
R825	RK3038	Chip R	ERJ3GSYJ102V
R826	RK3026	Chip R	ERJ3GSYJ101V
R827	RK3056	Chip R	ERJ3GSYJ333V
R828	RK3050	Chip R	ERJ3GSYJ103V
R829	RK3014	Chip R	ERJ3GSYJ100V
R830	RK3032	Chip R	ERJ3GSYJ331V
R831	RK3026	Chip R	ERJ3GSYJ101V
R832	RK3026	Chip R	ERJ3GSYJ101V
R833	RK3033	Chip R	ERJ3GSYJ391V
R834	RK3042	Chip R	ERJ3GSYJ222V
R835	RK3038	Chip R	ERJ3GSYJ102V
R836	RK3026	Chip R	ERJ3GSYJ101V
R838	RK3042	Chip R	ERJ3GSYJ222V
R839	RK3026	Chip R	ERJ3GSYJ101V
R840	RK3062	Chip R	ERJ3GSYJ104V
R841	RK3042	Chip R	ERJ3GSYJ222V
R842	RK3033	Chip R	ERJ3GSYJ391V

Ref. No.	Parts No.	Description	Parts Name
R843	RK3046	Chip R	ERJ3GSYJ472V
R844	RK3030	Chip R	ERJ3GSYJ221V
R845	RK3034	Chip R	ERJ3GSYJ471V
R846	RK3050	Chip R	ERJ3GSYJ103V
R847	RK3034	Chip R	ERJ3GSYJ471V
R848	RK3014	Chip R	ERJ3GSYJ100V
R849	RK3034	Chip R	ERJ3GSYJ471V
R850	RK3054	Chip R	ERJ3GSYJ223V
R851	RK3046	Chip R	ERJ3GSYJ472V
R852	RK3028	Chip R	ERJ3GSYJ151V
R853	RK3026	Chip R	ERJ3GSYJ101V
R854	RK3022	Chip R	ERJ3GSYJ470V
R855	RK3018	Chip R	ERJ3GSYJ220V
R856	RK3050	Chip R	ERJ3GSYJ103V
R857	RK3038	Chip R	ERJ3GSYJ102V
R858	RK3030	Chip R	ERJ3GSYJ221V
R859	RK3051	Chip R	ERJ3GSYJ123V
R860	RK3034	Chip R	ERJ3GSYJ471V
R861	RK3032	Chip R	ERJ3GSYJ331V
R862	RK3038	Chip R	ERJ3GSYJ102V
R863	RK3062	Chip R	ERJ3GSYJ104V
R864	RK3032	Chip R	ERJ3GSYJ331V
R865	RK3026	Chip R	ERJ3GSYJ101V
R866	RK3034	Chip R	ERJ3GSYJ471V
R867	RK3034	Chip R	ERJ3GSYJ471V
R868	RK3062	Chip R	ERJ3GSYJ104V
R869	RK3034	Chip R	ERJ3GSYJ471V
R870	RK3026	Chip R	ERJ3GSYJ101V
R871	RK3042	Chip R	ERJ3GSYJ222V
R872	RK3038	Chip R	ERJ3GSYJ102V
R873	RK3034	Chip R	ERJ3GSYJ471V
R874	RK3054	Chip R	ERJ3GSYJ223V
R875	RK3026	Chip R	ERJ3GSYJ101V
R876	RK3058	Chip R	ERJ3GSYJ473V
R877	RK3026	Chip R	ERJ3GSYJ101V
R878	RK3001	Chip R	ERJ3GSYR00V
R879	RK3042	Chip R	ERJ3GSYJ222V
R881	RK3050	Chip R	ERJ3GSYJ103V
R882	RK3050	Chip R	ERJ3GSYJ103V
R883	RK3050	Chip R	ERJ3GSYJ103V
R884	RK3050	Chip R	ERJ3GSYJ103V
R885	RK3050	Chip R	ERJ3GSYJ103V
R886	RK3050	Chip R	ERJ3GSYJ103V
R887	RK3050	Chip R	ERJ3GSYJ103V
R888	RK3050	Chip R	ERJ3GSYJ103V
R889	RK3026	Chip R	ERJ3GSYJ101V

Ref. No.	Parts No.	Description	Parts Name
R890	RK3024	Chip R	ERJ3GSYJ680V
R891	RK3030	Chip R	ERJ3GSYJ221V
R892	RK3030	Chip R	ERJ3GSYJ221V
R893	RK3030	Chip R	ERJ3GSYJ221V
R894	RK3052	Chip R	ERJ3GSYJ153V
RL701	UL0010	Relay	FBR22012
TC701	CT0012	Trimmer	CTZ-10AW
TC702	CT0034	Trimmer	CTZ35-30CW1-P
TC703	CT0034	Trimmer	CTZ35-30CW1-P
TC704	CT0034	Trimmer	CTZ35-30CW1-P
TC705	CT0012	Trimmer	CTZ-10AW
TH701	XS0014	Thermistor	TBPS1R223K460H50
VR701	RH0104	Trim Pot	EVMIYSX50BE4
VR702	RH0104	Trim Pot	EVMIYSX50BE4
X701	X00065	Crystal	49U-30.00MHz
X702	X00066	Crystal	49U-9.420MHz
X703	X00067	Crystal	49U-9.875MHz
T20056	49U		
T20056	49U		
T20056	49U		
UA0048			SMCD26x50-BDx6-P1.0
UP0289A		P. C. B	Circuit Board A
VCO1 Unit			
C924	CS0372	ChipTantalum	TMCMB1C106MTR
C925	CU3035	Chip C	C1608JB1H102KT-A
C926	CU3035	Chip C	C1608JB1H102KT-A
C927	CU3035	Chip C	C1608JB1H102KT-A
C928	CU3035	Chip C	C1608JB1H102KT-A
C929	CS0372	ChipTantalum	TMCMB1C106MTR
C930	CU3035	Chip C	C1608JB1H102KT-A
C931	CU3035	Chip C	C1608JB1H102KT-A
C932	CU3051	Chip C	C1608JB1E223KT-A
C933	CU3022	Chip C	C1608CH1H820JT-A
C934	CU3024	Chip C	C1608CH1H121JT-A
C935	CU3012	Chip C	C1608CH1H120JT-A
C936	CU3011	Chip C	C1608CH1H100CT-A
C937	CU3006	Chip C	C1608CH1H050CT-A
C938	CU3035	Chip C	C1608JB1H102KT-A
C939	CS0382	ChipTantalum	TMCMB1A226MTR
CN901	UE0185	Connector	B6P-BC-2
D931	XD0233	Diode	1SV217TPH4
IC704	XA0292	IC	MC12019DR2
L931	QA0109	Coil	QA0109
L932	QC0043	Chip L	NL322522T-2R2J
Q931	XE0006	FET	2SK210GR-TE85L

PLL Unit/VCO1 Unit/VCO2 Unit

Ref. No.	Parts No.	Description	Parts Name
Q932	XT0059	Transistor	2SC3082KT1460
Q933	XT0095	Transistor	2SC4081T106R
R926	RK3050	Chip R	ERJ3GSYJ103V
R927	RK3030	Chip R	ERJ3GSYJ221V
R928	RK3026	Chip R	ERJ3GSYJ101V
R929	RK3065	Chip R	ERJ3GSYJ184V
R930	RK3038	Chip R	ERJ3GSYJ102V
R931	RK3050	Chip R	ERJ3GSYJ103V
R932	RK3062	Chip R	ERJ3GSYJ104V
R933	RK3062	Chip R	ERJ3GSYJ104V
R934	RK3028	Chip R	ERJ3GSYJ151V
R935	RK3050	Chip R	ERJ3GSYJ103V
R936	RK3050	Chip R	ERJ3GSYJ103V
R937	RK3030	Chip R	ERJ3GSYJ221V
R939	RK3038	Chip R	ERJ3GSYJ102V
TS0106			VCO Case (A)
VCO2 Unit			
C941	CU3035	Chip C	C1608JB1H102KT-A
C942	CU3021	Chip C	C1608CH1H680JT-A
C943	CU3020	Chip C	C1608CH1H560JT-A
C944	CU3017	Chip C	C1608CH1H330JT-A
C945	CU3012	Chip C	C1608CH1H120JT-A
C946	CU3012	Chip C	C1608CH1H120JT-A
C947	CU3004	Chip C	C1608CH1H030CT-A
C948	CU3035	Chip C	C1608JB1H102KT-A
C949	CU3004	Chip C	C1608CH1H030CT-A
C950	CS0382	ChipTantalum	TMCMB1A226MTR
C951	CU3035	Chip C	C1608JB1H102KT-A
C952	CU3035	Chip C	C1608JB1H102KT-A
C953	CU3035	Chip C	C1608JB1H102KT-A
C954	CU3035	Chip C	C1608JB1H102KT-A
C955	CU3035	Chip C	C1608JB1H102KT-A
C956	CS0237	ChipTantalum	TMCMB1A475MTR
C957	CU3047	Chip C	C1608JB1H103KT-A
C958	CU3035	Chip C	C1608JB1H102KT-A
CN902	UE0185	Connector	B6P-BC-2
D941	XD0233	Diode	1SV217TPH4
L941	QA0110	Coil	QA0110
L942	QC0047	Chip L	NL322522T-4R7J
Q941	XE0006	FET	2SK210GR-TE85L
Q942	XT0059	Transistor	2SC3082KT1460
Q943	XT0059	Transistor	2SC3082KT1460
Q944	XT0059	Transistor	2SC3082KT1460
Q945	XT0059	Transistor	2SC3082KT1460
R925	RK3062	Chip R	ERJ3GSYJ104V

Ref. No.	Parts No.	Description	Parts Name
R940	RK3026	Chip R	ERJ3G5YJ101V
R941	RK3050	Chip R	ERJ3G5YJ103V
R942	RK3054	Chip R	ERJ3G5YJ223V
R943	RK3062	Chip R	ERJ3G5YJ104V
R944	RK3062	Chip R	ERJ3G5YJ104V
R945	RK3031	Chip R	ERJ3G5YJ271V
R946	RK3054	Chip R	ERJ3G5YJ223V
R947	RK3054	Chip R	ERJ3G5YJ223V
R948	RK3042	Chip R	ERJ3G5YJ222V
R949	RK3054	Chip R	ERJ3G5YJ223V
R950	RK3054	Chip R	ERJ3G5YJ223V
R951	RK3038	Chip R	ERJ3G5YJ102V
R952	RK3030	Chip R	ERJ3G5YJ221V
R953	RK3030	Chip R	ERJ3G5YJ221V
R954	RK3040	Chip R	ERJ3G5YJ152V
R955	RK3032	Chip R	ERJ3G5YJ331V
R956	RK3035	Chip R	ERJ3G5YJ561V
R957	RK3036	Chip R	ERJ3G5YJ681V
R958	RK3050	Chip R	ERJ3G5YJ103V
R959	RK3047	Chip R	ERJ3G5YJ562V
TS0105			VCO Case(A)

## VCO3 Unit

C961	CU3026	Chip C	C1608CH1H181JT-A
C962	CU3011	Chip C	C1608CH1H100CT-A
C963	CU3020	Chip C	C1608CH1H560JT-A
C964	CU3013	Chip C	C1608CH1H150JT-A
C965	CU3012	Chip C	C1608CH1H120JT-A
C966	CU3006	Chip C	C1608CH1H050CT-A
C967	CU3035	Chip C	C1608JB1H102KT-A
C968	CS0382	ChipTantalum	TMCMB1A226MTR
C969	CU3035	Chip C	C1608JB1H102KT-A
C970	CU3035	Chip C	C1608JB1H102KT-A
C971	CU3022	Chip C	C1608CH1H820JT-A
C972	CU3009	Chip C	C1608CH1H080CT-A
C973	CU3018	Chip C	C1608CH1H390JT-A
C974	CU3012	Chip C	C1608CH1H120JT-A
C975	CU3010	Chip C	C1608CH1H090CT-A
C976	CU3006	Chip C	C1608CH1H050CT-A
C977	CU3035	Chip C	C1608JB1H102KT-A
C978	CS0382	ChipTantalum	TMCMB1A226MTR
C979	CU3035	Chip C	C1608JB1H102KT-A
C980	CU3035	Chip C	C1608JB1H102KT-A
C981	CU3018	Chip C	C1608CH1H390JT-A
C982	CU3005	Chip C	C1608CH1H040CT-A
C983	CU3017	Chip C	C1608CH1H330JT-A

Ref. No.	Parts No.	Description	Parts Name
C984	CU3011	Chip C	C1608CH1H100CT-A
C985	CU3006	Chip C	C1608CH1H050CT-A
C986	CU3006	Chip C	C1608CH1H050CT-A
C987	CU3035	Chip C	C1608JB1H102KT-A
C988	CS0382	ChipTantalum	TMCMB1A226MTR
C989	CU3035	Chip C	C1608JB1H102KT-A
C990	CU3035	Chip C	C1608JB1H102KT-A
C991	CU3101	Chip C	C1608JB1C473KT-A
C992	CU3101	Chip C	C1608JB1C473KT-A
CN903	UE0183	Connector	B4P-BC-2
CN904	UE0182	Connector	B3P-BC-2
D961	XD0233	Diode	1SV2177PH4
D962	XD0266	Diode	DAP236V T106
D963	XD0233	Diode	1SV2177PH4
D965	XD0233	Diode	1SV2177PH4
D966	XD0272	Diode	1SS356 TW11
L962	QA0110	Coil	QA0110
L963	QC0047	Chip L	NL322522T-4R7J
L965	QA0110	Coil	QA0110
L966	QC0047	Chip L	NL322522T-4R7J
L968	QA0110	Coil	QA0110
L969	QC0047	Chip L	NL322522T-4R7J
O961	XE0006	FET	2SK210GR-TE85L
O962	XU0140	Transistor	DTC124EUT106
O963	XE0006	FET	2SK210GR-TE85L
O964	XU0140	Transistor	DTC124EUT106
O965	XE0006	FET	2SK210GR-TE85L
O966	XU0140	Transistor	DTC124EUT106
R960	RK3054	Chip R	ERJ3G5YJ223V
R961	RK3062	Chip R	ERJ3G5YJ104V
R962	RK3062	Chip R	ERJ3G5YJ104V
R963	RK3028	Chip R	ERJ3G5YJ151V
R964	RK3044	Chip R	ERJ3G5YJ332V
R965	RK3030	Chip R	ERJ3G5YJ221V
R966	RK3062	Chip R	ERJ3G5YJ104V
R967	RK3062	Chip R	ERJ3G5YJ104V
R968	RK3028	Chip R	ERJ3G5YJ151V
R969	RK3044	Chip R	ERJ3G5YJ332V
R970	RK3030	Chip R	ERJ3G5YJ221V
R971	RK3062	Chip R	ERJ3G5YJ104V
R972	RK3062	Chip R	ERJ3G5YJ104V
R973	RK3028	Chip R	ERJ3G5YJ151V
R974	RK3044	Chip R	ERJ3G5YJ332V
R975	RK3030	Chip R	ERJ3G5YJ221V
R976	RK3046	Chip R	ERJ3G5YJ472V
R977	RK3046	Chip R	ERJ3G5YJ472V

Ref. No.	Parts No.	Description	Parts Name
R978	RK3046	Chip R	ERJ3G5YJ472V
TC961	CT0012	Trimmer	CTZ-10A
TC962	CT0C12	Trimmer	CTZ-10A
TC963	CT0C12	Trimmer	CTZ-10A
TS0107			VCO Case(B)

## NFB Unit

C633	CM0012	Mica C.	DM19 472J 500V
C637	CM0012	Mica C.	DM19 472J 500V
D604	XD0264	Diode	MA30-B(TX)
D605	XD0264	Diode	MA30-B(TX)
L612	OC0048	Chip L	NL322522T-100J
R621	RK6026	Chip R	ERJ1WYJ101H
R622	RK6026	Chip R	ERJ1WYJ101H
R623	RK6023	Chip R	ERJ1WYJ560H
R626	RK6026	Chip R	ERJ1WYJ101H
R627	RK6026	Chip R	ERJ1WYJ101H
R628	RK6023	Chip R	ERJ1WYJ560H
TH601	XS0021	Thermistor	TBPS1R103K440H5Q

## TONE Unit

C801	CS0049	ChipTantalum	TMCSA1C105MTR 70T
C902	CU3047	Chip C	C1608JB1H103KT-A 70T
C903	CS0372	ChipTantalum	TMCMB1C106MTR 70T
C904	CS0220	ChipTantalum	TMCMA1C225MTR 70T
C905	CU3006	Chip C	C1608CH1H050CT-A 70T
C907	CU3101	Chip C	C1608JB1C473KT-A 70T
CN991	UX1049	Wire	EJ19U 70T
D901	XD0254	Diode	1SS355 TE17 70T
IC901	XA0052	IC	S7116A 70T
O901	XT0095	Transistor	2SC4081T106R 70T
R901	RK3050	Chip R	ERJ3G5YJ103V 70T
R902	RK3058	Chip R	ERJ3G5YJ473V 70T
R903	RK3026	Chip R	ERJ3G5YJ101V 70T
R904	RK3066	Chip R	ERJ3G5YJ224V 70T
R905	RK3046	Chip R	ERJ3G5YJ472V 70T
R906	RK3057	Chip R	ERJ3G5YJ393V 70T
R907	RK3034	Chip R	ERJ3G5YJ471V 70T
R908	RK3057	Chip R	ERJ3G5YJ393V 70T
R909	RK3058	Chip R	ERJ3G5YJ473V 70T
R910	RK3054	Chip R	ERJ3G5YJ223V 70T
SW901	UD0205	Switch	SGM18001A 70T
X901	XB0301	Ctystal	FARC4CA0380K01R 70T

## FILT Unit

C501	CU7003	Chip C	C3K31NAR102K
------	--------	--------	--------------

Ref. No.	Parts No.	Description	Parts Name
C502	CU3047	Chip C	C1608JB1H103KT-A
C503	CC5095	Ceramic C.	RCC12SL471J-L46AU
C504	CC5093	Ceramic C.	RCC12SL391J-L46AU
C505	CM0008	Mica C.	DM19 222J 500V
C506	CC5083	Ceramic C.	RCC08SL151J-L46AU
C507	CC5095	Ceramic C.	RCC12SL471J-L46AU
C508	CU3047	Chip C	C1608JB1H103KT-A
C509	CU3047	Chip C	C1608JB1H103KT-A
C510	CC5091	Ceramic C.	RCC11SL331J-L46AU
C511	CC5089	Ceramic C.	RCC10SL271J-L46AU
C512	CC5095	Ceramic C.	RCC12SL471J-L46AU
C513	CC5077	Ceramic C.	RCC07SL820J-L46AU
C514	CC5099	Ceramic C.	HM15SJ-SL681J
C515	CU3047	Chip C	C1608JB1H103KT-A
C516	CU3047	Chip C	C1608JB1H103KT-A
C517	CC5095	Ceramic C.	RCC12SL471J-L46AU
C518	CC5069	Ceramic C.	RCC06SL470J-L46AU
C519	CC5099	Ceramic C.	HM15SJ-SL681J
C520	CC5081	Ceramic C.	RCC07SL121J-L46AU
C521	CC5079	Ceramic C.	RCC07SL101J-L46AU
C522	CU3047	Chip C	C1608JB1H103KT-A
C523	CU3047	Chip C	C1608JB1H103KT-A
C524	CC5083	Ceramic C.	RCC08SL151J-L46AU
C525	CC5068	Ceramic C.	RCC06SL390J-L46AU
C526	CC5091	Ceramic C.	RCC11SL331J-L46AU
C527	CC5077	Ceramic C.	RCC07SL820J-L46AU
C528	CC5085	Ceramic C.	RCC09SL181J-L46AU
C529	CU3047	Chip C	C1608JB1H103KT-A
C530	CU3047	Chip C	C1608JB1H103KT-A
C531	CC5079	Ceramic C.	RCC07SL101J-L46AU
C532	CC5060	Ceramic C.	RCC05SL150J-L46AE
C533	CC5085	Ceramic C.	RCC09SL181J-L46AU
C534	CC5069	Ceramic C.	RCC06SL470J-L46AU
C535	CC5077	Ceramic C.	RCC07SL820J-L46AU
C536	CU3047	Chip C	C1608JB1H103KT-A
C537	CU3047	Chip C	C1608JB1H103KT-A
C538	CC5064	Ceramic C.	RCC05SL220J-L46AE
C539	CC5065	Ceramic C.	RCC05SL270J-L46AE
C540	CC5081	Ceramic C.	RCC07SL121J-L46AU
C542	CC5064	Ceramic C.	RCC05SL220J-L46AE
C543	CC5073	Ceramic C.	RCC06SL560J-L46AU
C544	CU3047	Chip C	C1608JB1H103KT-A
C545	CU3027	Chip C	C1608CH1H221JT-A
C546	CU3027	Chip C	C1608CH1H221JT-A
C547	CU3029	Chip C	C1608JB1H331KT-A
C548	CU3031	Chip C	C1608JB1H471KT-A

FILT Unit

Ref. No.	Parts No.	Description	Parts Name
C549	CU3031	Chip C.	C1608JB1H471KT-A
C550	CU3047	Chip C.	C1608JB1H103KT-A
C551	CU3047	Chip C.	C1608JB1H103KT-A
C552	CU3047	Chip C.	C1608JB1H103KT-A
C553	CU3047	Chip C.	C1608JB1H103KT-A
C554	CU3047	Chip C.	C1608JB1H103KT-A
C555	CU3047	Chip C.	C1608JB1H103KT-A
C556	CU3047	Chip C.	C1608JB1H103KT-A
C557	CU3047	Chip C.	C1608JB1H103KT-A
C558	CU3047	Chip C.	C1608JB1H103KT-A
C559	CU3047	Chip C.	C1608JB1H103KT-A
C560	CU3047	Chip C.	C1608JB1H103KT-A
C561	CU3047	Chip C.	C1608JB1H103KT-A
C562	CU3019	Chip C.	C1608CH1H470JT-A
C563	CU3027	Chip C.	C1608CH1H221JT-A
C564	CU3019	Chip C.	C1608CH1H470JT-A
C565	CU3015	Chip C.	C1608CH1H220JT-A
C566	CU3023	Chip C.	C1608CH1H101JT-A
C567	CU3031	Chip C.	C1608JB1H471KT-A
C568	CU3029	Chip C.	C1608JB1H331KT-A
C569	CU3031	Chip C.	C1608JB1H471KT-A
C570	CU9032	Chip C.	CM316CH680J100AT
C572	CU7007	Chip C.	C2C31N2ACG820J
C573	CU7026	Chip C.	C2C31N2ACG060D
C574	CU7037	Chip C.	C2C31N2ACG470J
C575	CU7003	Chip C.	C3K31NARI02K
C579	CU3047	Chip C.	C1608JB1H103KT-A
C580	CU3024	Chip C.	C1608CH1H121JT-A
C581	CU3026	Chip C.	C1608CH1H181JT-A
C582	CU3024	Chip C.	C1608CH1H121JT-A
C583	CU8042	Chip C.	C2012JB1C104KT-A
C584	CU8042	Chip C.	C2012JB1C104KT-A
C585	CU3047	Chip C.	C1608JB1H103KT-A
C586	CU8042	Chip C.	C2012JB1C104KT-A
C587	CU8042	Chip C.	C2012JB1C104KT-A
C588	CU8042	Chip C.	C2012JB1C104KT-A
C589	CU8042	Chip C.	C2012JB1C104KT-A
C590	CC5095	Ceramic C.	RCC12SL471J-L46AU
C591	CC5099	Ceramic C.	HM15SJ-SL681J
C592	CC5095	Ceramic C.	RCC12SL471J-L46AU
C593	CU3023	Chip C.	C1608CH1H101JT-A
CN501	UE0136	Connector	TMF-J02X-A1
CN502	UE0136	Connector	TMF-J02X-A1
CN503	RD0108	Resistor	JPW01 R-01
CN504	RD0108	Resistor	JPW01 R-01
CN506	UE0043	Connector	PI22A02M

Ref. No.	Parts No.	Description	Parts Name
CN507	UE0235	Connector	00-6208-000-112-001
CN508	UE0070	Connector	PI22A04M
CN509	UE0071	Connector	PI22A05M
D501	XD0039	Diode	RLS4152 TE-11
D502	XD0039	Diode	RLS4152 TE-11
D503	XD0039	Diode	RLS4152 TE-11
D504	XD0039	Diode	RLS4152 TE-11
D505	XD0039	Diode	RLS4152 TE-11
D506	XD0039	Diode	RLS4152 TE-11
D507	XD0127	Diode	MA704WA
D508	XD0014	Diode	M1308
D509	XD0014	Diode	M1308
D510	XD0127	Diode	MA704WA
D511	XD0039	Diode	RLS4152 TE-11
D512	XD0039	Diode	RLS4152 TE-11
D513	XD0039	Diode	RLS4152 TE-11
L501	QR0004	Coil	Troidal Core QR0004
L502	QR0005	Coil	Troidal Core QR0005
L503	QR0006	Coil	Troidal Core QR0006
L504	QR0007	Coil	Troidal Core QR0007
L505	QR0009	Coil	Troidal Core QR0009
L506	QR0008	Coil	Troidal Core QR0008
L507	QR0011	Coil	Troidal Core QR0011
L508	QR0010	Coil	Troidal Core QR0010
L509	QKA75H	Air Core Coil	COIL MR10.0 7.5T 1.0
L510	QKA65H	Air Core Coil	COIL MR10.0 6.5T 1.0
L511	QKA45H	Air Core Coil	COIL MR10.0 4.5T 1.0
L512	QKA55H	Air Core Coil	COIL MR10.0 5.5T 1.0
L513	QR0013	Coil	Troidal Core QR0013
L514	QR0017	Coil	QR0017
L515	OC0124	Chip L.	NL322522T-R15J-3
L516	OC0124	Chip L.	NL322522T-R15J-3
L517	OC0338	Coil	SP0406-3R3K-6
L518	QKA75G	Air Core Coil	COIL MR5.0 7.5T 0.6
L519	QR0013	Coil	Troidal Core QR0013
L520	QKA75G	Air Core Coil	COIL MR5.0 7.5T 0.6
L521	QKA55G	Air Core Coil	COIL MR5.0 5.5T 0.6
L524	OC0123	Chip L.	NL322522T-R12J-3
L525	OC0126	Chip L.	NL322522T-R22J-3
L526	OC0126	Chip L.	NL322522T-R22J-3
L527	OC0473	Chip L.	LOH4N100J04
L528	OC0087	Chip L.	NL322522T-121J
L529	OC0087	Chip L.	NL322522T-121J
L530	OC0087	Chip L.	NL322522T-121J
L531	OC0048	Chip L.	NL322522T-100J
L532	OC0048	Chip L.	NL322522T-100J

Ref. No.	Parts No.	Description	Parts Name
L533	OC0048	Chip L.	NL322522T-100J
L534	RD1013	Resistor	JPW02R-01
L535	RD1013	Resistor	JPW02R-01
L536	OC0132	Chip L.	NL322522T-R68J-3
Q501	XU0155	Transistor	DTB123YK
Q502	XU0148	Transistor	DTC144EUT106
Q503	XE0026	FET	2SK2171-4
Q504	XU0078	Transistor	UN521L-TX
Q505	XT0067	Transistor	FMA4
Q506	XT0067	Transistor	FMA4
Q507	XT0067	Transistor	FMA4
Q508	XU0116	Transistor	DTA123EUT106
Q509	XU0175	Transistor	UN5111-TX
R501	FK4029	Chip R.	ERJ-12YJ181H
R502	FK4024	Chip R.	ERJ-12YJ680H
R503	FK0107	Chip R.	ERJ6GEYJ000V
R504	FK3050	Chip R.	ERJ3GSYJ103V
R505	FK3050	Chip R.	ERJ3GSYJ103V
R506	FK3052	Chip R.	ERJ3GSYJ153V
R507	FK3052	Chip R.	ERJ3GSYJ153V
R508	FK3062	Chip R.	ERJ3GSYJ104V
R509	FK3062	Chip R.	ERJ3GSYJ104V
R510	FK3038	Chip R.	ERJ3GSYJ102V
R511	FK3038	Chip R.	ERJ3GSYJ102V
R512	FK3038	Chip R.	ERJ3GSYJ102V
R513	FK3038	Chip R.	ERJ3GSYJ102V
R514	FK3038	Chip R.	ERJ3GSYJ102V
R515	FK3038	Chip R.	ERJ3GSYJ102V
R516	FK4028	Chip R.	ERJ-12YJ151H
R517	FK3026	Chip R.	ERJ3GSYJ101V
R518	FK3026	Chip R.	ERJ3GSYJ101V
R519	FK3018	Chip R.	ERJ3GSYJ220V
R520	FK3026	Chip R.	ERJ3GSYJ101V
R521	FK3052	Chip R.	ERJ3GSYJ153V
R522	FK3066	Chip R.	ERJ3GSYJ224V
R523	FK3046	Chip R.	ERJ3GSYJ472V
R524	FK4029	Chip R.	ERJ-12YJ181H
R525	FK3046	Chip R.	ERJ3GSYJ472V
R526	FK0069	Chip R.	ERJ6GEYJ104V
R527	FK0065	Chip R.	ERJ6GEYJ683V
R528	FK3034	Chip R.	ERJ3GSYJ471V
R529	FK3038	Chip R.	ERJ3GSYJ102V
R530	FK0008	Chip R.	ERJ6GEYJ330V
R531	FK3023	Chip R.	ERJ3GSYJ560V
R532	FK0008	Chip R.	ERJ6GEYJ330V
R533	FK3001	Chip R.	ERJ3GSY0R00V

FILT Unit/PA Unit

Ref. No.	Parts No.	Description	Parts Name
R534	RD0108	Resistor	JPW01 R-01
RL501	UL0006	Relay	AG201344
RL502	UL0006	Relay	AG201344
RL503	UL0006	Relay	AG201344
RL504	UL0006	Relay	AG201344
RL505	UL0006	Relay	AG201344
RL506	UL0006	Relay	AG201344
RL507	UL0006	Relay	AG201344
RL508	UL0006	Relay	AG201344
RL509	UL0006	Relay	AG201344
RL510	UL0006	Relay	AG201344
RL511	UL0006	Relay	AG201344
RL512	UL0006	Relay	AG201344
RL513	UL0006	Relay	AG201344
RL514	UL0010	Relay	FBR22012
RL515	UL0010	Relay	FBR22012
SA501	EU0001	Surge absorber	DSA-301LA
TC501	CT0035	Trimmer	ECV12W20X53T
TC502	CT0035	Trimmer	ECV12W20X53T
W506	UX1079	Wire	ER- 2
W507	UA0050	Power cord	FFC SMC0-12X95-BD
W508	UX1080	Wire	ER- 3
YZ0042			Adhesion G-17 1g
PA Unit			
C601	CU8042	Chip C.	C2012JB1C104KT-A
C602	CU8042	Chip C.	C2012JB1C104KT-A
C603	CU3006	Chip C.	C1608CH1H050CT-A
C604	CU3012	Chip C.	C1608CH1H120JT-A
C606	CU3029	Chip C.	C1608JB1H331KT-A
C607	CU3023	Chip C.	C1608CH1H101JT-A
C608	CU8042	Chip C.	C2012JB1C104KT-A
C609	CU3035	Chip C.	C1608JB1H102KT-A
C610	CE0350	Electrolytic C.	16MV100HC
C611	CU8042	Chip C.	C2012JB1C104KT-A
C612	CU3035	Chip C.	C1608JB1H102KT-A
C613	CU8002	Chip C.	C2012JB1H103KT-A
C614	CU0089	Chip C.	C2012CH1H331J
C615	CU8002	Chip C.	C2012JB1H103KT-A
C616	CU9023	Chip C.	C3216CH1H121JT-A
C617	CE0350	Electrolytic C.	16MV100HC
C618	CU8042	Chip C.	C2012JB1C104KT-A
C619	CU3035	Chip C.	C1608JB1H102KT-A
C620	CU7005	Chip C.	C2C31N2ACG330J
C621	CU9009	Chip C.	C3216JB1H103KT-A
C622	CU7038	Chip C.	C2C31N2ACG560J

Ref. No.	Parts No.	Description	Parts Name
C623	CU8032	Chip C.	C2012JB1E223KT-A
C624	CU8032	Chip C.	C2012JB1E223KT-A
C625	CU8032	Chip C.	C2012JB1E223KT-A
C626	CM0005	Mica C.	DM19 152J 500V
C627	CU8032	Chip C.	C2012JB1E223KT-A
C628	CU8032	Chip C.	C2012JB1E223KT-A
C629	CU8032	Chip C.	C2012JB1E223KT-A
C630	CE0364	Electrolytic C.	16MV475WB+TS
C631	CU8042	Chip C.	C2012JB1C104KT-A
C632	CU3035	Chip C.	C1608JB1H102KT-A
C634	CM0004	Mica C.	DM19 102J 500V
C635	CC5095	Ceramic C.	RCC12SL471J-L46AU
C636	CC5067	Ceramic C.	RCC05SL330J-L46AE
C638	CU3035	Chip C.	C1608JB1H102KT-A
C639	CU8042	Chip C.	C2012JB1C104KT-A
C640	CU3047	Chip C.	C1608JB1H103KT-A
C641	CE0353	Electrolytic C.	16MV470HC
C642	CU8042	Chip C.	C2012JB1C104KT-A
C643	CU3047	Chip C.	C1608JB1H103KT-A
C644	CU3035	Chip C.	C1608JB1H102KT-A
C645	CU3035	Chip C.	C1608JB1H102KT-A
C646	CU3035	Chip C.	C1608JB1H102KT-A
C647	CE0343	Electrolytic C.	16MV 1000HC+T
C648	CU3047	Chip C.	C1608JB1H103KT-A
C649	CU9009	Chip C.	C3216JB1H103KT-A
C650	CU3047	Chip C.	C1608JB1H103KT-A
C651	CU3047	Chip C.	C1608JB1H103KT-A
C652	CU3047	Chip C.	C1608JB1H103KT-A
C653	CU3035	Chip C.	C1608JB1H102KT-A
C654	CE0201	Electrolytic C.	16MV10S2
C655	CE0353	Electrolytic C.	16MV470HC
C656	CU3047	Chip C.	C1608JB1H103KT-A
C657	CU3047	Chip C.	C1608JB1H103KT-A
C658	CU3047	Chip C.	C1608JB1H103KT-A
C659	CU3047	Chip C.	C1608JB1H103KT-A
C661	CU3047	Chip C.	C1608JB1H103KT-A
C662	CU3047	Chip C.	C1608JB1H103KT-A
C663	CU8042	Chip C.	C2012JB1C104KT-A
C664	CU8042	Chip C.	C2012JB1C104KT-A
C665	CU3047	Chip C.	C1608JB1H103KT-A
C666	CU8042	Chip C.	C2012JB1C104KT-A
C667	CU8042	Chip C.	C2012JB1C104KT-A
C668	CU3047	Chip C.	C1608JB1H103KT-A
C669	CU3047	Chip C.	C1608JB1H103KT-A
C670	CU3047	Chip C.	C1608JB1H103KT-A
C671	CU3023	Chip C.	C1608CH1H101JT-A

Ref. No.	Parts No.	Description	Parts Name
C672	CU3059	Chip C.	C1608JF1E1042T-A
C673	CU3059	Chip C.	C1608JF1E1042T-A
CN608	UE0071	Connector	P122A05M
CN609	UE0226	Connector	B2B-PH-K-S
CP601	UE0047	Round Pin	R9X10
CP602	UE0047	Round Pin	R9X10
CP603	UE0047	Round Pin	R9X10
CP604	UE0047	Round Pin	R9X10
CP605	UE0047	Round Pin	R9X10
CP606	UE0047	Round Pin	R9X10
CP607	UE0047	Round Pin	R9X10
CP608	UE0047	Round Pin	R9X10
CP609	UE0047	Round Pin	R9X10
CP610	UE0047	Round Pin	R9X10
CP611	UE0047	Round Pin	R9X10
D601	XD0263	Diode	MA27-B
D602	XD0039	Diode	RLS4152 TE-11
D606	XD0039	Diode	RLS4152 TE-11
D607	XD0265	Diode	SG5LR
D608	XD0231	Diode	DAP202U T106
D609	XD0039	Diode	RLS4152 TE-11
D610	XD0039	Diode	RLS4152 TE-11
D611	XD0039	Diode	RLS4152 TE-11
D612	XD0039	Diode	RLS4152 TE-11
FB601	QB0037	Ferrite Beads	ZBF253D-00
FB602	QB0037	Ferrite Beads	ZBF253D-00
FB603	QB0037	Ferrite Beads	ZBF253D-00
FB604	QB0037	Ferrite Beads	ZBF253D-00
FB605	QB0037	Ferrite Beads	ZBF253D-00
FB606	QB0038	Ferrite Beads	EXCELSA39
FB607	QB0008	Ferrite Beads	HF30ACB201209-T
IC601	XA0224	IC	NJM2904M-T1
J601	UJ0030	Jack	JPJ2545-01-510
J602	UJ0030	Jack	JPJ2545-01-510
L601	QC0044	Chip L.	NL322522T-2R7J
L602	QR0014A	Coil	Transformer QR0014A
L603	QC0039	Chip L.	NL322522T-1R0J
L604	QC0039	Chip L.	NL322522T-1R0J
L605	QC0048	Chip L.	NL322522T-100J
L606	QR0012	Coil	Troidal Core QR0012
L607	QR0015	Coil	Transformer QR0015
L608	QR0015	Coil	Transformer QR0015
L609	QR0012	Coil	Troidal Core QR0012
L610	QR0016	Coil	Transformer QR0016
L611	QR0012	Coil	Troidal Core QR0012
O607	XU0176	Transistor	UN2223-TX

Ref. No.	Parts No.	Description	Parts Name
O608	XU0176	Transistor	UN2223-TX
O609	XU0078	Transistor	UN521L-TX
O610	XJ0078	Transistor	UN521L-TX
R601	RK3001	Chip R.	ERJ3GSY0R00V
R602	RK3028	Chip R.	ERJ3GSYJ151V
R603	RK0028	Chip R.	ERJ6GEYJ471V
R604	RK0020	Chip R.	ERJ6GEYJ151V
R606	RK4083	Chip R.	ERJ14YJ5R6H
R607	RK4023	Chip R.	ERJ12YJ560H
R608	RK0028	Chip R.	ERJ6GEYJ471V
R609	RK4030	Chip R.	ERJ12YJ221H
R610	RK4030	Chip R.	ERJ12YJ221H
R611	RK4055	Chip R.	ERJ-14YJ470H
R612	RK4055	Chip R.	ERJ-14YJ470H
R613	RK4030	Chip R.	ERJ12YJ221H
R614	RK0005	Chip R.	ERJ6GEYJ220V
R615	RK4014	Chip R.	ERJ12YJ100V
R616	RK4014	Chip R.	ERJ12YJ100V
R617	RD3007	Resistor	ERX1SJ3R3
R618	RD3007	Resistor	ERX1SJ3R3
R619	RD3007	Resistor	ERX1SJ3R3
R620	RD3007	Resistor	ERX1SJ3R3
R624	RK4014	Chip R.	ERJ12YJ100V
R625	RK4014	Chip R.	ERJ12YJ100V
R629	RE0017	Cement R.	ERX3SJA4R7
R630	RK0039	Chip R.	ERJ6GEYJ222V
R631	RK0039	Chip R.	ERJ6GEYJ222V
R632	RK0005	Chip R.	ERJ6GEYJ220V
R633	RK3026	Chip R.	ERJ3GSYJ101V
R634	RK3026	Chip R.	ERJ3GSYJ101V
R635	RK3026	Chip R.	ERJ3GSYJ101V
R636	RK0028	Chip R.	ERJ6GEYJ471V
R637	RK3058	Chip R.	ERJ3GSYJ473V
R638	RK3026	Chip R.	ERJ3GSYJ101V
R639	RK6024	Chip R.	ERJ1WYJ680H
R640	RK6020	Chip R.	ERJ1WYJ330H
R641	RK3070	Chip R.	ERJ3GSYJ474V
R642	RK3050	Chip R.	ERJ3GSYJ103V
R643	RK3054	Chip R.	ERJ3GSYJ223V
R644	RK3050	Chip R.	ERJ3GSYJ103V
R645	RK3053	Chip R.	ERJ3GSYJ183V
R646	RK3056	Chip R.	ERJ3GSYJ333V
R647	RK3048	Chip R.	ERJ3GSYJ682V
R648	RK3052	Chip R.	ERJ3GSYJ153V
R649	RK3044	Chip R.	ERJ3GSYJ332V
R650	RK3038	Chip R.	ERJ3GSYJ102V

Ref. No.	Parts No.	Description	Parts Name
R651	RK3001	Chip R.	ERJ3GSY0R00V
R653	RK3001	Chip R.	ERJ3GSY0R00V
R654	RK3026	Chip R.	ERJ3GSYJ101V
R655	RK0008	Chip R.	ERJ6GEYJ330V
R656	RK3042	Chip R.	ERJ3GSYJ222V
R657	RK3046	Chip R.	ERJ3GSYJ472V
R658	RK1107	Chip R.	ERJ8GEY0R00
R659	RK3035	Chip R.	ERJ3GSYJ561V
R660	RK3026	Chip R.	ERJ3GSYJ101V
R661	RK3026	Chip R.	ERJ3GSYJ101V
RL601	UL0006	Relay	AG201344
RL602	UL0012	Relay	AJK3241
RL603	UL0006	Relay	AG201344
VR601	RH0164	Trim Pot	EVND8AA03BE2
VR602	RH0165	Trim Pot	EVND8AA03BE3
W601	UX1081	Wire	PA- 1
W602	UX1081	Wire	PA- 1
W604	UX1081	Wire	PA- 1
W605	UX1082	Wire	PA 1
W606	UX1083	Wire	PA- 2
W607	UX1084	Wire	PA-FILTER 1
TT1001			Tube 0.7 1mm
TT1001			Tube 0.7 1mm
TT1001			Tube 0.7 1mm
TT1001			Tube 0.7 1mm
TT1001			Tube 0.7 1mm
UP0279		P. C. B	Transformer Board
UP0290B		P. C. B	Circuit Board B
JACK			
C691	CU3047	Chip C.	C1608JB1H103KT-A
C692	CU3047	Chip C.	C1608JB1H103KT-A
C693	CU3047	Chip C.	C1608JB1H103KT-A
C694	CU3047	Chip C.	C1608JB1H103KT-A
J691	UJ0031	Jack	HSJ1332-01-050
J692	UJ0032	Jack	HSJ1332-01-040
W691	UX1086	Wire	JACK- 1
FRONT			
C1002	CU3035	Chip C.	C1608JB1H102KT-A
C1003	CU3043	Chip C.	C1608JB1H472KT-A
C1004	CU3043	Chip C.	C1608JB1H472KT-A
C1005	CU3039	Chip C.	C1608JB1H222KT-A
C1006	CU3035	Chip C.	C1608JB1H102KT-A
C1007	CU3035	Chip C.	C1608JB1H102KT-A
C1008	CU3039	Chip C.	C1608JB1H222KT-A



FRONT

Ref. No.	Parts No.	Description	Parts Name
C1009	CU3035	Chip C	C1608JB1H102KT-A
C1010	CS0230	ChipTantalum	TMCMA1E105MTR
C1011	CU3059	Chip C	C1608JF1E104ZT-A
C1014	CU3017	Chip C	C1608CH1H330JT-A
C1015	CU3017	Chip C	C1608CH1H330JT-A
C1016	CU3059	Chip C	C1608JF1E104ZT-A
C1017	CE0351	Electrolytic C	16MV220HC
C1018	CU3047	Chip C	C1608JB1H103KT-A
C1019	CE0315	Electrolytic C	ECEV1CA470P
C1020	CU3035	Chip C	C1608JB1H102KT-A
C1021	CS0061	ChipTantalum	TMCSA1V224MTR
C1022	CE0375	Electrolytic C	16CV220BS
C1023	CU3035	Chip C	C1608JB1H102KT-A
C1024	CE0375	Electrolytic C	16CV220BS
C1025	CS0230	ChipTantalum	TMCMA1E105MTR
C1026	CU3047	Chip C	C1608JB1H103KT-A
C1027	CU3043	Chip C	C1608JB1H472KT-A
C1028	CE0315	Electrolytic C	ECEV1CA470P
C1029	CU3035	Chip C	C1608JB1H102KT-A
C1030	CU3059	Chip C	C1608JF1E104ZT-A
C1031	CU3047	Chip C	C1608JB1H103KT-A
C1032	CU3047	Chip C	C1608JB1H103KT-A
C1033	CU3047	Chip C	C1608JB1H103KT-A
C1034	CU3047	Chip C	C1608JB1H103KT-A
C1035	CU3047	Chip C	C1608JB1H103KT-A
C1036	CU3035	Chip C	C1608JB1H102KT-A
C1037	CU3047	Chip C	C1608JB1H103KT-A
C1038	CU3047	Chip C	C1608JB1H103KT-A
C1039	CU3047	Chip C	C1608JB1H103KT-A
C1040	CU3035	Chip C	C1608JB1H102KT-A
C1041	CU3035	Chip C	C1608JB1H102KT-A
C1042	CU3027	Chip C	C1608CH1H221JT-A
C1043	CU3027	Chip C	C1608CH1H221JT-A
C1044	CU3035	Chip C	C1608JB1H102KT-A
C1045	CU3032	Chip C	C1608JB1H561KT-A
CN1001	UE0222	Connector	2357-0890
CN1002	UE0265	Connector	B12B-EH
CN1003	UE0174	Connector	B13B-ZR
CN1004	UE0165	Connector	B4B-ZR
D1002	XL0043	LED	CL-170R-CD-T
D1003	XL0042	LED	CL-170G-CD-T
D1004	XD0230	Diode	DAN202U T106
D1005	XD0230	Diode	DAN202U T106
D1007	XD0230	Diode	DAN202U T106
D1008	XD0254	Diode	1SS355 TE-17
D1009	XD0230	Diode	DAN202U T106

Ref. No.	Parts No.	Description	Parts Name
D1010	XD0230	Diode	DAN202U T106
D1011	XD0230	Diode	DAN202U T106
D1016	XD0254	Diode	1SS355 TE-17
D1017	XD0254	Diode	1SS355 TE-17
D1018	XD0160	Diode	DTZ4.3B TT11
D1019	XD0254	Diode	1SS355 TE-17
D1020	XD0230	Diode	DAN202U T106
D1021	XD0230	Diode	DAN202U T106
D1022	XD0254	Diode	1SS355 TE-17
D1024	XD0230	Diode	DAN202U T106
D1025	XD0230	Diode	DAN202U T106
D1026	XD0230	Diode	DAN202U T106
D1027	XD0230	Diode	DAN202U T106
D1028	XD0230	Diode	DAN202U T106
D1029	XD0230	Diode	DAN202U T106
D1030	XD0230	Diode	DAN202U T106
IC1001	XA0296	IC	MC14071BF
IC1002	XA0347	IC	TC4030BF
IC1003	XA0299	IC	BU4001BF
IC1004	XA0295	IC	MC14024BF
IC1005	XA0351	IC	24LC16B
IC1006	XA0393	IC	CPU DX-70
IC1007	XA0338	IC	L78L05B-TL/TR
IC1008	XA0075	IC	NJM78L08UA-TE1
IC1009	XA0303	IC	LC75821W
L1001	OC0489	Chip L	LOH4N221J04
LCD1001	EL0027	LCD	LCD DX70
PL1001	EP0009	Lamp	B0031-20805A
PL1002	EP0009	Lamp	B0031-20805A
PL1003	EP0009	Lamp	B0031-20805A
PL1004	EP0009	Lamp	B0031-20805A
Q1001	XT0094	Transistor	2SA1576T106R
Q1002	XU0061	Transistor	UN5211-TX
Q1003	XT0061	Transistor	2SB1132T1000
Q1004	XT0095	Transistor	2SC4081T106R
Q1005	XT0095	Transistor	2SC4081T106R
Q1006	XU0061	Transistor	UN5211-TX
Q1009	XU0061	Transistor	UN5211-TX
Q1010	XU0061	Transistor	UN5211-TX
Q1011	XU0061	Transistor	UN5211-TX
R1005	RK3034	Chip R	ERJ3G5YJ471V
R1006	RK3034	Chip R	ERJ3G5YJ471V
R1007	RK3034	Chip R	ERJ3G5YJ471V
R1008	RK3058	Chip R	ERJ3G5YJ473V
R1009	RK3058	Chip R	ERJ3G5YJ473V
R1010	RK3062	Chip R	ERJ3G5YJ104V

Ref. No.	Parts No.	Description	Parts Name
R1011	RK3066	Chip R	ERJ3G5YJ224V
R1012	RK3062	Chip R	ERJ3G5YJ104V
R1013	RK3074	Chip R	ERJ3G5YJ105V
R1014	RK3052	Chip R	ERJ3G5YJ153V
R1015	RK3054	Chip R	ERJ3G5YJ223V
R1016	RK3052	Chip R	ERJ3G5YJ104V
R1017	RK3056	Chip R	ERJ3G5YJ224V
R1018	RK3052	Chip R	ERJ3G5YJ104V
R1019	RK3074	Chip R	ERJ3G5YJ105V
R1020	RK3052	Chip R	ERJ3G5YJ153V
R1021	RK3050	Chip R	ERJ3G5YJ103V
R1022	RK3054	Chip R	ERJ3G5YJ223V
R1023	RK3074	Chip R	ERJ3G5YJ105V
R1024	RK3050	Chip R	ERJ3G5YJ103V
R1025	RK3050	Chip R	ERJ3G5YJ103V
R1026	RK3058	Chip R	ERJ3G5YJ473V
R1027	RK3050	Chip R	ERJ3G5YJ103V
R1028	RK3050	Chip R	ERJ3G5YJ103V
R1029	RK3034	Chip R	ERJ3G5YJ471V
R1030	RK3034	Chip R	ERJ3G5YJ471V
R1031	RK0130	Chip R	ERJ6GEYJ4R7V
R1032	RK3046	Chip R	ERJ3G5YJ472V
R1033	RK3030	Chip R	ERJ3G5YJ221V
R1034	RK3038	Chip R	ERJ3G5YJ102V
R1035	RK3050	Chip R	ERJ3G5YJ103V
R1036	RK3050	Chip R	ERJ3G5YJ103V
R1037	RK3050	Chip R	ERJ3G5YJ103V
R1038	RK3050	Chip R	ERJ3G5YJ103V
R1039	RK3050	Chip R	ERJ3G5YJ103V
R1040	RK3050	Chip R	ERJ3G5YJ103V
R1041	RK3050	Chip R	ERJ3G5YJ103V
R1042	RK3044	Chip R	ERJ3G5YJ332V
R1043	RK3058	Chip R	ERJ3G5YJ473V
R1044	RK3058	Chip R	ERJ3G5YJ473V
R1045	RK3038	Chip R	ERJ3G5YJ102V
R1046	RK3050	Chip R	ERJ3G5YJ103V
R1047	RK3050	Chip R	ERJ3G5YJ103V
R1048	RK3050	Chip R	ERJ3G5YJ103V
R1049	RK3050	Chip R	ERJ3G5YJ103V
R1050	RK3050	Chip R	ERJ3G5YJ103V
R1051	RK3038	Chip R	ERJ3G5YJ102V
R1052	RK3047	Chip R	ERJ3G5YJ562V
R1053	RK3046	Chip R	ERJ3G5YJ472V
R1054	RK3050	Chip R	ERJ3G5YJ103V
R1055	RK3038	Chip R	ERJ3G5YJ102V
R1056	RK3034	Chip R	ERJ3G5YJ471V

FRONT

Ref. No.	Parts No.	Description	Parts Name
R1057	RK3034	Chip R	ERJ3G5YJ471V
R1058	RK3038	Chip R	ERJ3G5YJ102V
R1059	RK3034	Chip R	ERJ3G5YJ471V
R1060	RK3026	Chip R	ERJ3G5YJ101V
R1061	RK3030	Chip R	ERJ3G5YJ221V
R1062	RK3042	Chip R	ERJ3G5YJ222V
R1063	RK3030	Chip R	ERJ3G5YJ221V
R1064	RK3050	Chip R	ERJ3G5YJ103V
R1065	RK3038	Chip R	ERJ3G5YJ102V
R1066	RK3034	Chip R	ERJ3G5YJ471V
R1067	RK3034	Chip R	ERJ3G5YJ471V
R1068	RK3034	Chip R	ERJ3G5YJ471V
R1069	RK3034	Chip R	ERJ3G5YJ471V
R1070	RK3034	Chip R	ERJ3G5YJ471V
R1071	RK3034	Chip R	ERJ3G5YJ471V
R1072	RK3034	Chip R	ERJ3G5YJ471V
R1073	RK3034	Chip R	ERJ3G5YJ471V
R1074	RK3034	Chip R	ERJ3G5YJ471V
R1075	RK3034	Chip R	ERJ3G5YJ471V
R1076	RK3030	Chip R	ERJ3G5YJ221V
R1077	RK3058	Chip R	ERJ3G5YJ473V
R1079	RK3074	Chip R	ERJ3G5YJ105V
R1080	RK3001	Chip R	ERJ3G5Y0R00V
R1081	RK3001	Chip R	ERJ3G5Y0R00V 70T
R1083	RK3001	Chip R	ERJ3G5Y0R00V
R1087	RK3001	Chip R	ERJ3G5Y0R00V
R1093	RK3001	Chip R	ERJ3G5Y0R00V
R1094	RK3062	Chip R	ERJ3G5YJ104V
R1095	RK3062	Chip R	ERJ3G5YJ104V
R1096	RK3062	Chip R	ERJ3G5YJ104V
R1097	RK3062	Chip R	ERJ3G5YJ104V
R1098	RK3050	Chip R	ERJ3G5YJ103V
S1001	UR0009	Switch	EC11B1S204
S1002	UR0010	Switch	EC24B50B0
SW1001	UU0020	Switch	JPM1110-0101
SW1002	UU0020	Switch	JPM1110-0101
SW1003	UU0020	Switch	JPM1110-0101
SW1004	UU0020	Switch	JPM1110-0101
SW1005	UU0020	Switch	JPM1110-0101
SW1006	UU0020	Switch	JPM1110-0101
SW1007	UU0020	Switch	JPM1110-0101
SW1008	UU0020	Switch	JPM1110-0101
SW1009	UU0020	Switch	JPM1110-0101
SW1010	UU0020	Switch	JPM1110-0101
SW1011	UU0020	Switch	JPM1110-0101
SW1012	UU0020	Switch	JPM1110-0101



# ADJUSTMENT

## 1) PA unit Adjustment

### Required Test Equipment

- Digital voltage meter
- DC current meter  
300~500mA  
3A
- DC regulated power supply  
13.80V 25A or more  
(should be equipped with 20~25A current limit and current meter)
- Power meter  
100W (1.9~30MHz)
- Linear detector
- SG or RF generator  
1.9~60MHz, -10~+10dBm

### PA Unit Adjustment Points

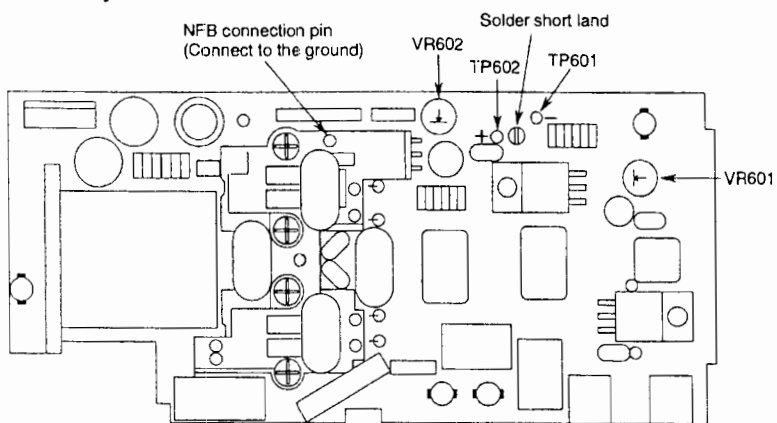

### Filter Unit Adjustment Points

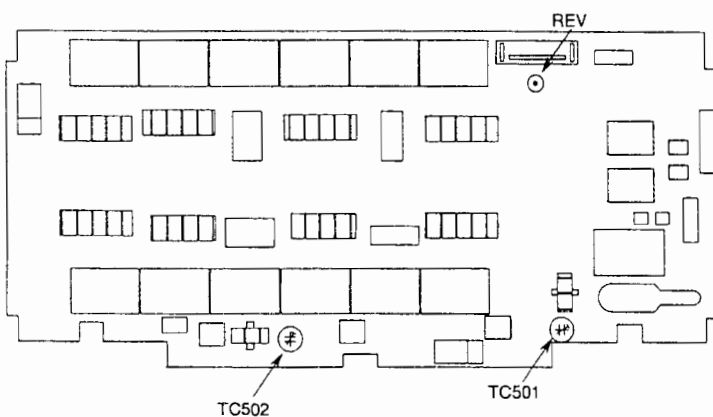

### Idle Current Adjustment Setting

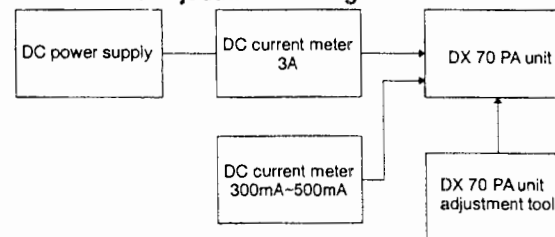

Adjustment the idle current without input signal.

### SWR Adjustment Setting

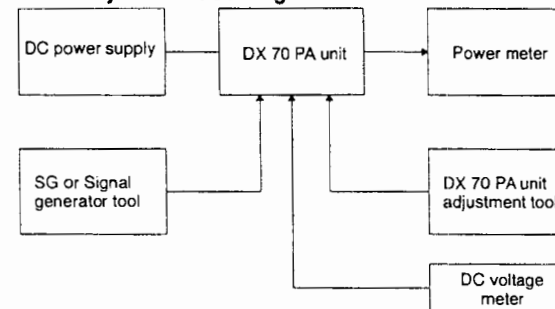

Adjust SWR at approximately 50W.

### PA Adjustment

Item	Condition	Measurement		Adjustment		
		Equipment	Terminal	Unit	Parts	Method
Idling current 2SC1972 x 2	SSG: OFF Mode: USB VR601, 602: min.	Current Meter 300~500mA	TP601 ⊖ TP602 ⊕	PA	VR601	Desolder the short-land Connect the current meter between TP601 and TP602, then adjust VR601 to 100mA. Solder the short-land
Idling current 2SC2904 x 2	SSG: OFF Mode: USB	Current Meter 3A	CN605 unit total current		VR602	Connect terminal pin of NFB unit to the ground, check the total current in transmission mode. Then remove terminal pin from ground, adjust VR602 to increase 300mA.
Connect TP1 and TP2 by soldering after adjusting.						
SWR detection	f=1.9MHz SG >>PA unit	Voltage Meter	REV	Filter	TC501	Adjust the output power to 50W, then adjust the TC501 so that REV voltage is min.
	f=52MHz				TC502	Adjust the output power to 5W, then adjust the TC501 so that REV voltage is min.
When you adjust the finished goods, set the mode to SSB, adjust the input level of microphone, and set the output power to about 50W. (To protect from accidental damage). Then proceed to "8) Transmission Adjustment".						

## 2) PLL Adjustment

### Required Test Equipment

1. Digital voltage meter
2. DC regulated power supply 13.80V 5A or more
3. Frequency counter 500MHz or more
4. Spectrum Analyzer 1GHz or more
5. Oscilloscope 100MHz or more

### PLL Unit Adjustment Points

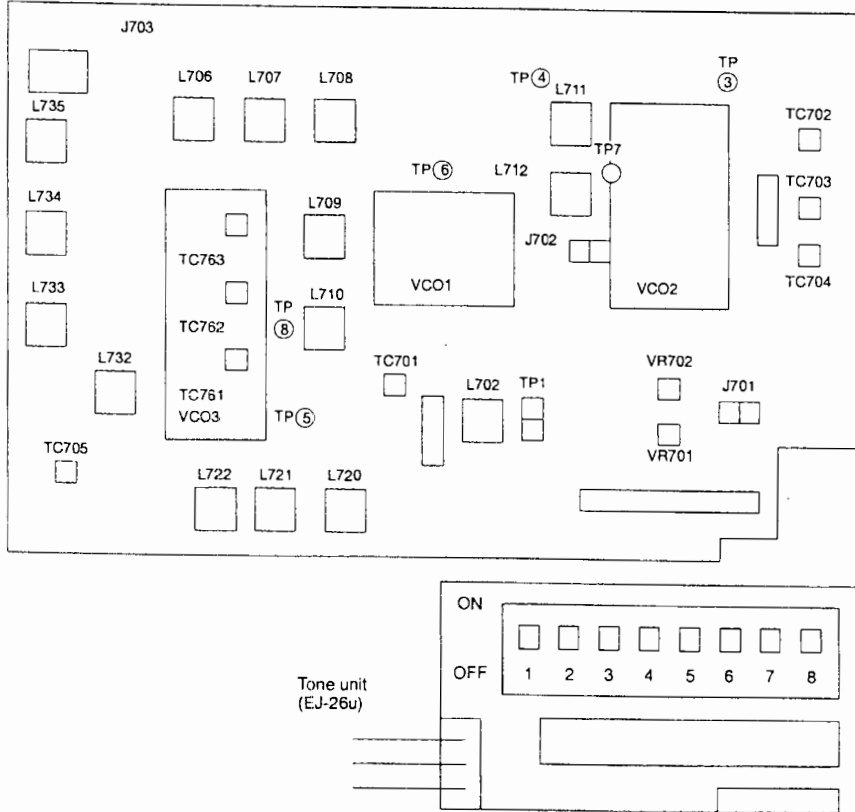

Item	Condition	Measurement			Adjustment			
		Equipment	Unit	Terminal	Unit	Parts	Method	
VCO1 Frequency	PD1=1.2V	Freq. Counter	VCO1	CN90 1-3			175MHz or above	
	PD1=4.3V						155MHz or below	
VCO2 Frequency	PD1=1.5~4V	Freq. Counter	VCO2	CN90 2-4			VCO2 freq.: 71MHz	
Attach the VCO to PLL, then adjust the unit after installing the PLL to the unit.								
VCO2 Lock range	f=7.100MHz	Digital tester	PLL	TP7		Check	1.5V~4V	
VCO1 Lock range	f=7.0999MHz						TP6	1V~3V
	f=7.1000MHz						3V~4.3V	
VCO3 Lock range	f=0.1500MHz			TP8	VCO3	TC961	2.5V	
	f=10.4999MHz						TC961	When the voltage is 6.45V or below, adjust the unit to 6.5V again. (6.45V~7.0V)
	f=10.5000MHz						TC962	2.5V
	f=21.4999MHz						TC962	When the voltage is 6.45V or below, adjust the unit to 6.5V again. (6.45V~7.0V)
	f=21.5000MHz						TC963	2.5V
	f=29.9999MHz						Check	6.5V or below
2nd LO Level	f=7.100MHz	Oscilloscope		TP4	PLL	L711 L712	Turn the coils to the max. repeatedly.	
1st LO Level	f=7.100MHz						TP5	L709 L710
	f=7.100MHz				L706 L707 L708	Turn the coils to the max. repeatedly.		

Item	Condition	Measurement			Adjustment				
		Equipment	Unit	Terminal	Unit	Parts	Method		
Frequency (Mode)	RX LSB	Freq. Counter	PLL	TP3	PLL	TC702	9873.60kHz +/- 0.02kHz		
	RX USB					TC704	9876.40kHz +/- 0.02kHz		
	RX AM and FM					TC703	9875.00kHz +/- 0.02kHz		
	RX CWU					Check	9875.80kHz +/- 0.3kHz		
	RX CWL						9874.20kHz +/- 0.3kHz		
Frequency (IF Shift)	RX LSB	Spectrum Analyzer	PLL	J701	PLL	VR702	453.60kHz +/- 0.1kHz		
	TX LSB					VR701	453.60kHz +/- 0.01kHz		
	RX LT, (IF Shift center)					Check	453.30kHz +/- 0.2kHz		
	TX LT, (IF Shift center)						453.50kHz +/- 0.2kHz		
	RX UT, (IF Shift center)						456.70kHz +/- 0.2kHz		
	TX UT, (IF Shift center)						456.50kHz +/- 0.2kHz		
	Frequency					f=7.1000MHz, FM	Spectrum Analyzer	PLL	J703
Level	f=7.100MHz, USB	J701	Check	-6~0dBm f=456.4kHz					
Level	f=7.100MHz, USB			J702	1~6dBm f=71.295MHz				
Level	f=53.9999MHz	J703	Check	L720 L721 L722	Turn the coils to the max. repeatedly. f=123.75MHz				
Level	f=53.9999MHz			L732 L733 L734 L745	Turn the coils to the max. repeatedly f=123.75MHz 1~6dBm				
Spurious	f=53.9999MHz			TC705	Spurious min. (60dB or more)				
Level	f=150kHz f=10.400MHz f=10.500MHz f=21.400MHz f=21.500MHz f=29.9999MHz	Spectrum Analyzer	PLL	J701	PLL	Check			

### 3) Tone Unit Adjustment

- 1 Attach EJ26U to DX70.
- 2 When the subaudible Tone is ON in FM mode, adjust the unit according to following table.
- 3 When the subaudible Tone is OFF in FM mode, the tone should not be emitted.

Item	Condition	Measurement			Adjustment		
		Equipment	Unit	Terminal	Unit	Parts	Method
Tone Frequency	250.3Hz 1 2 3 4 5 6 7 8 * . . . . .	Freq. Counter	EJ26 u	CN99 1~1			249.6~251.0Hz
Tone Frequency	156.3Hz 1 2 3 4 5 6 7 8 * . . . . .	Freq. Counter	EJ26 u	CN99 1~1			156.2~157.2Hz
Tone Level	156.3Hz 1 2 3 4 5 6 7 8 * . . . . .	Oscilloscope	EJ26 u	CN99 1~1			1.8~3.0V p-p
Tone Level	156.3Hz 1 2 3 4 5 6 7 8 * . . . . .	Oscilloscope	EJ26 u	CN99 1~1			2.8~3.8V p-p
Tone Level	156.3Hz 1 2 3 4 5 6 7 8 * . . . . .	Oscilloscope	EJ26 u	CN99 1~1			3.8~4.8V p-p
Final Setting	88.5Hz 1 2 3 4 5 6 7 8 * . . . . .						Attach to the DX70T after the tone level obtains 88.5Hz.

\* indicates the number is ON.

### Required Test Equipment

1. Digital voltage meter
2. DC regulated power supply      13.80V 3A or more
3. SG      about 200MHz
4. Distortion meter, AF voltage meter
5. 8Ω speaker
6. Oscilloscope
7. (NB adjustment tool)

### Main Unit Adjustment Setting

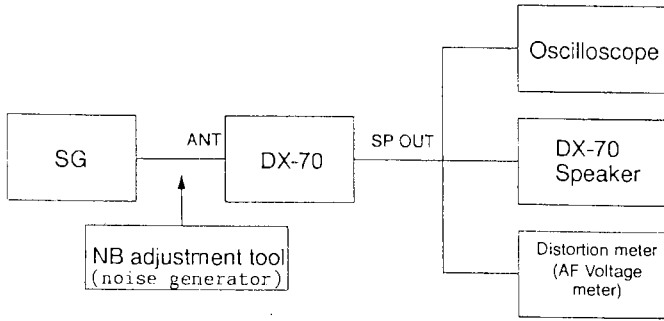

### Main Unit Adjustment Points

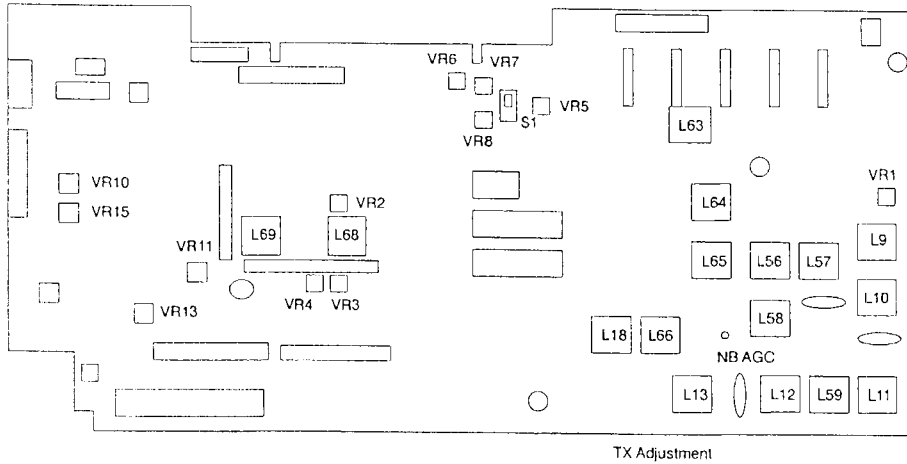

### 4) Sensitivity Adjustment

SG Output Frequency: 14.1000MHz      Connect to HF Antenna Terminal.  
 Frequency: 14.0993MHz      Mode: USB      RIT: OFF      AGC: FAST      NB: OFF  
 RF Gain: +10dB      ΔF: Center      Squelch VR: Turn the knob counterclockwise fully.  
 Filter: Wide

Item	Condition	Measurement		Adjustment		
		Equipment	Terminal	Unit	Parts	Method
Tuning	SG output: 0dB $\mu$ Mod: OFF AF output: 300mV	Audio Voltmeter	SP	Main	L56 L57 L58 L59 L12 L13 L66 L68 L69	Adjust every following group repeatedly to obtain the maximum receiving signal;
	Mode: FM f=14.1000MHz SG output: 0dB $\mu$ Mod: 1kHz, 3.5kHzDEV	Distortion Meter			L59 L12 L13	Adjust repeatedly to obtain the maximum SINAD. SINAD should be 13dB or more.
	SG output: 60dB $\mu$ 1kHz, 3.5kHzDEV			Check		SINAD should be 30dB or more. If SINAD is below 30dB, adjust L59, L12 and L13 again.
	SG output: -6dB $\mu$ Mod: OFF Mode: USB f=14.0993MHz AF output: 300mV	Audio Voltmeter		Check		Make sure that S/N is 10.5dB or more by turning ON/OFF SG output.
	SG output: 10dB $\mu$ Mod: 1kHz, 30% Mode: AM f=14.1000MHz			Check		Make sure S/N is 10dB or more by turning ON/OFF SG modulation.

## 5) Noise Blanker Adjustment

SG Output Frequency: 14.1000MHz

Frequency: 14.0993MHz

RF Gain: +10dB

Filter: Wide

Mode: USB

ΔF: Center

Connect to HF Antenna Terminal.

RIT: OFF      AGC: FAST      NB: OFF

Squelch VR: Turn the knob counterclockwise fully.

Item	Condition	Measurement		Adjustment		
		Equipment	Terminal	Unit	Parts	Method
Tuning	SG output: 0dB <sub>μ</sub> Mod: OFF Mode: USB f=14.0993MHz NB: ON RF Gain: +10dB	Oscilloscope	NB AGC (MAIN)	Main	L63 L64 L65	Adjust the coils, and set DC voltage of the terminal to the minimum with the oscilloscope.

## 6) S Meter Adjustment

Item	Condition	Measurement		Adjustment		
		Equipment	Terminal	Unit	Parts	Method
RX Total Gain	SG output: 40dB <sub>μ</sub> Mod: OFF Mode: USB f=14.0993MHz RF Gain: 0dB	AF Voltmeter	SP	Main	VR2	Adjust SP output by setting the AF gain to about 1V. The output level should be 0dB. Adjust only the noise output to -28dB by turning OFF SG output.
S Meter	SG output: 20dB <sub>μ</sub> Mod: OFF SG output: 40dB <sub>μ</sub>	S Meter	S Meter	Main	VR10 VR15	The indicator between first and second digits is turned ON. The 9th digit starts flashing. Adjust VR10 and VR15 repeatedly.
	SG: OFF				Check	S Meter is not turned ON.
Squelch	SG: OFF		BUSY RX LED (Green) AF output		Check	

## 7) Receiving Function Adjustment

SG Output Frequency: 14.1000MHz

Frequency: 14.0993MHz

RF Gain: +10dB

Filter: Wide

Mode: USB

ΔF: Center

Connect to HF Antenna Terminal.

RIT: OFF      AGC: FAST      NB: OFF

Squelch VR: Turn the knob counterclockwise fully.

Item	Condition	Measurement		Adjustment		
		Equipment	Terminal	Unit	Parts	Method
AGC	SG output: 40dB <sub>μ</sub> Output: ON/OFF Mod: OFF		S Meter		Check	Switch AGC. When SG is turned OFF, the meter moves slowly in SLOW, and fast in FAST.
RF GAIN	SG output: 40dB <sub>μ</sub>		S Meter		Check	Switch the RF GAIN from +10dB orderly, the meter swings shorter and shorter.
FILTER Switching	Output: OFF Mode: USB, AM, CW				Check	Switch the FILTER in every mode (except FM), the noise sound should be changed.
Band Sensitivity	SG output: -6dB <sub>μ</sub> f=1.9000MHz f=3.6000MHz f=7.0000MHz f=10.1000MHz f=21.1000MHz f=28.1000MHz Mode: USB or LSB	Audio Voltmeter	SP	Main	Check	In USB mode, SG frequency is -700Hz. In LSB mode, SG frequency is +700Hz. Make sure that S/N is 10dB or more.
	50MHz Sensitivity					Connect SG to 50MHz antenna terminal. SG output: -10dB <sub>μ</sub> SG freq.: 52.1000MHz Mode: USB f=52.0993MHz
	SG output: -4dB <sub>μ</sub> Mod: 1kHz, 3.5kHzDev Mode: FM f=52.0000MHz	Distortion Meter			Check	

### Required Test Equipment

1. Digital voltage meter
2. DC current meter 20~30A
3. DC regulated power supply 13.80V 25A or more  
(should be equipped with 20~25A current limit)
4. Power meter 100W (1.9~30MHz)  
10W (1.9~60MHz or more)
5. Linear detector
6. AF generator (600Ω)
7. AF voltage meter
8. Oscilloscope
9. Electronic keyer (CW telegraphy key)
10. TUNE operation tool

### TX Adjustment Setting

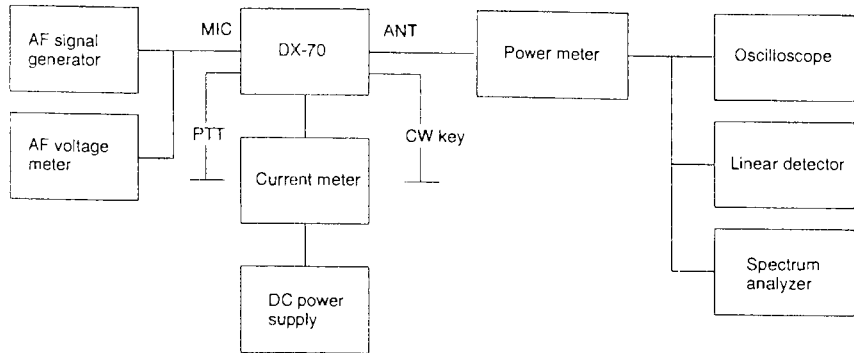

### 8) Transmission Adjustment

Connect the power meter to HF antenna terminal.  
 Frequency: 7.1000MHz      Mode: USB      Power: High  
 Speech Compressor (SET mode): OFF      FM-TONE: OFF

Item	Condition	Measurement		Adjustment		
		Equipment	Terminal	Unit	Parts	Method
Tuning	Slide S1 to rear panel side. AG output: -50dBm	Power Meter	HF Antenna Terminal	Main	L18 L11 L10 L9	Adjust to the maximum power. (Adjust the AG input level so that the power becomes the maximum at about 50W.
Current Limit	AG output: OFF Mode: FM Set VR7 to 9 o'clock. Set VR6 to 3 o'clock.	Current Meter	Power Supply Terminal		VR6	Turn VR6 counterclockwise so that the total current becomes 20A. Be careful not to run much current for short time.
Power	Mode: FM	Power Meter	HF Antenna Terminal		VR7	Turn VR7 clockwise to decrease the power, then adjust to 100W.
	Slide S1 to front panel side.			VR5	Turn VR5 to obtain the power of 50W.	
	Slide S1 to rear panel side. Operate TUNE with tool.			VR8	Turn VR8 to obtain the power of 10W.	
	f: 52.0000MHz Mode: FM		50MHz Antenna Terminal	Filter	TC502	Set the power to 10W or approximate value. 10W +/- within 1W
FM Frequency Deviation	AG output: -30dBm f: 52.0000MHz Mode: FM	Linear Detector		Main	VR13	Adjust the maximum frequency deviation to 4.3kHz.
	FM-TONE: ON (only the unit equipped with TONE)				Check	The frequency deviation is increased. (Approx. 5kHz)



Connect the power meter to 50MHz antenna terminal.

Frequency: 52.000MHz      Mode: USB      Power: High  
 Speech Compressor (SET mode): OFF      FM-TONE: OFF

Item	Condition	Measurement		Adjustment		
		Equipment	Terminal	Unit	Parts	Method
Filter Tuning	AG output: -30dBm Mode: FM FM-TONE: OFF	Oscilloscope (Linear Detector)	50MHz Antenna Terminal	Main	L11 L10 L9	Set the AM modulation factor to the minimum. It should be 5% or below.
Carrier Balance	AG output: OFF f: 7.1000MHz Mode: LSB/USB	Oscilloscope	HF Antenna Terminal		VR3 VR4	Adjust VR3 and VR4 so that the carrier suppression is 50dB (1/300) or below at 100W. The carrier suppression should be decreased in both USB and LSB.
CW Wave Form	Mode: CW-L/CW-U Electronic-keyer (dot): approx. 20mS				VR11 Check	Make sure of the wave form. The wave form of rise and fall should be symmetry. (The inclination is approx. 5mS.) The side tone of CW is should be heard from speaker.
Low Power	Mode: FM Power: Low				Power Meter	Check
AM Power	AG output: OFF Mode: AM Power: High	Check	35~50W			
Band Power	Mode: FM Band (MHz): 1.9, 3.5, 10, 14, 18, 21, 24, 28	Check	Make sure that the power is 95~105W.			

## 9) Spurious Adjustment

Connect the power meter to HF or 50MHz antenna terminal.

Frequency: 52.000MHz      Mode: FM      Power: High  
 Speech Compressor (SET mode): OFF      FM-TONE: OFF

Item	Condition	Measurement		Adjustment		
		Equipment	Terminal	Unit	Parts	Method
Spurious Balance	AG output: OFF Mode: FM FM-TONE: OFF f: 52.0000MHz	ATT + spectrum Analyzer	50MHz Antenna Terminal	Main	VR1	Balance the spurious to obtain the minimum value. -60dB or below
Spurious	AG output: OFF Mode: FM Band (MHz): 1.9, 3.5, 10, 14, 18, 21, 24, 28		HF Antenna Terminal		Check	-52dB or below (-47dB or below in 10MHz band only)
			L9		Adjust so that the value is within the regulation. (Adjust L9 when the spurious is not -52dB or below in 24/28MHz band.)	
Carrier Balance	AG output: OFF Mode: LSB/USB		Check (VR3 VR4)		-50dB or below (Adjust VR3 and VR4 when the carrier suppression is not -50dB or below.)	
Modulation	Mode: CW Keying: OFF f: 53.99MHz		Check		-60dB or below	
	Mode: FM, AM, USB/LSB Connect the microphone.		Monitor Transceiver		Check	Make sure the modulation sound in every mode.

# PC BORD VIEW

1) CPU Unit Side A

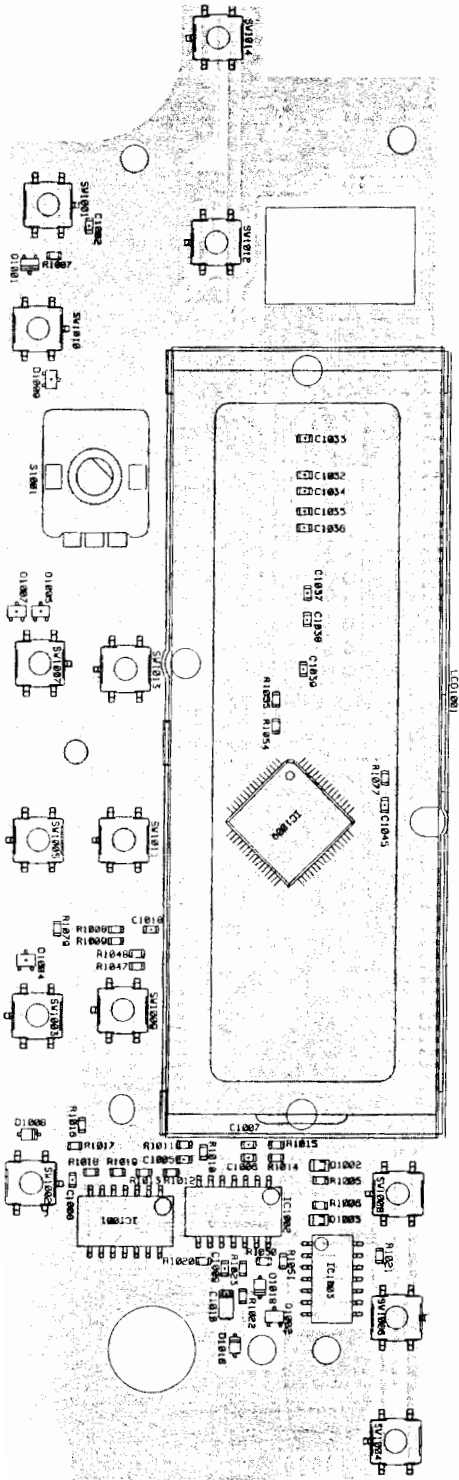

2) CPU Unit Side B

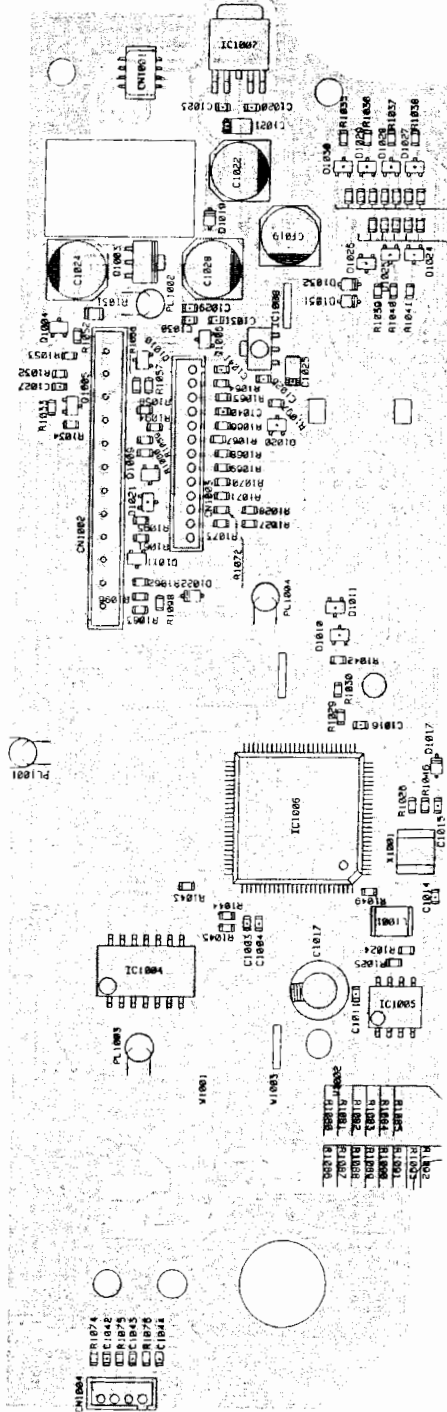

3) Vol. Unit Side A

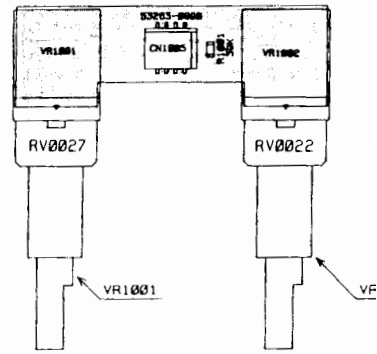

4) Vol. Unit Side B



5) Jack Unit Side A

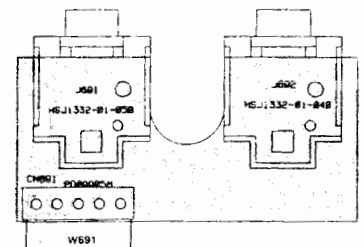

6) Jack Unit Side B

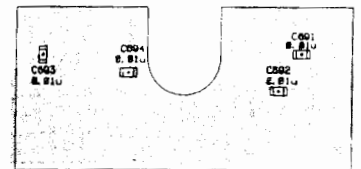

7) Main Unit Side A

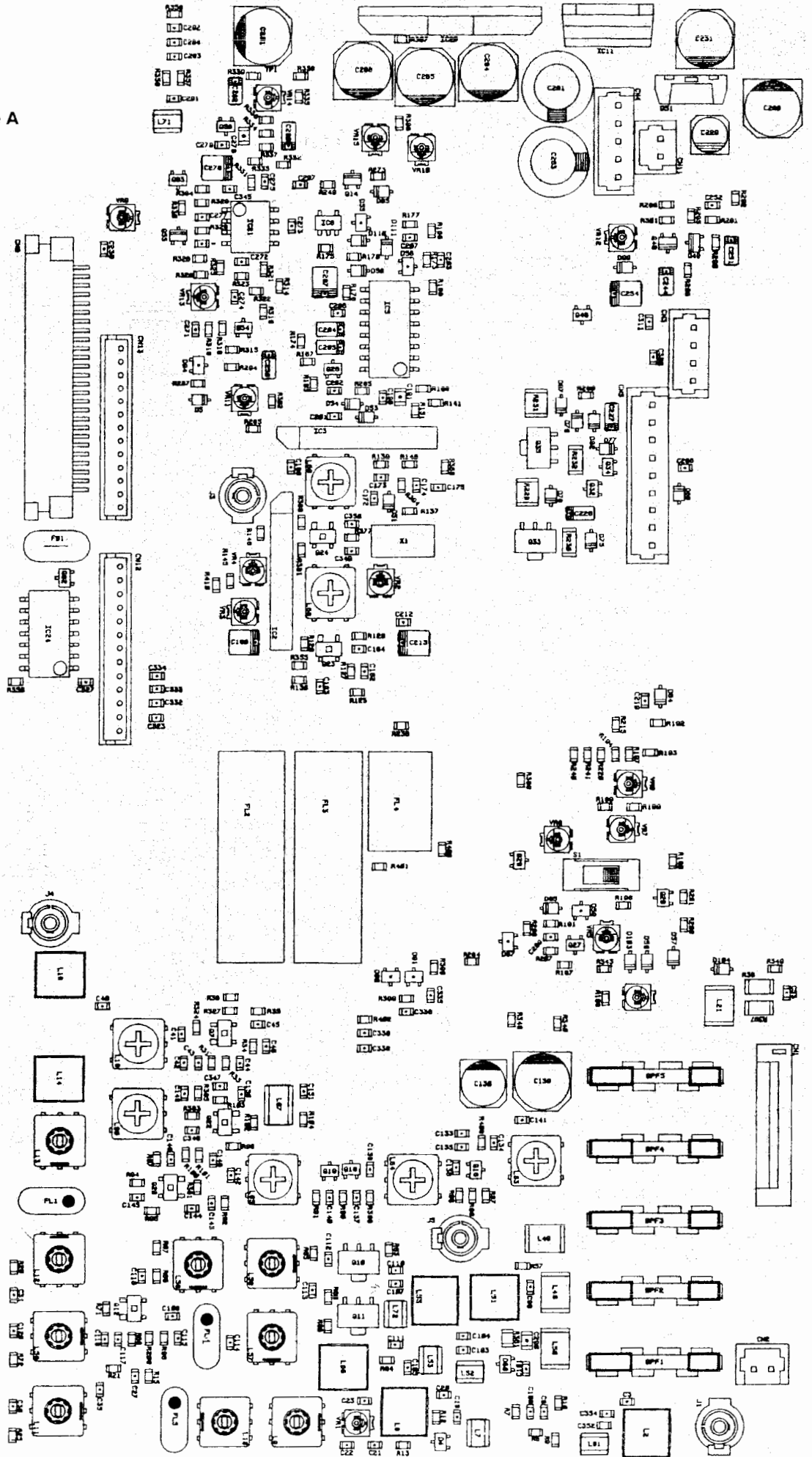

8) Main Unit Side B

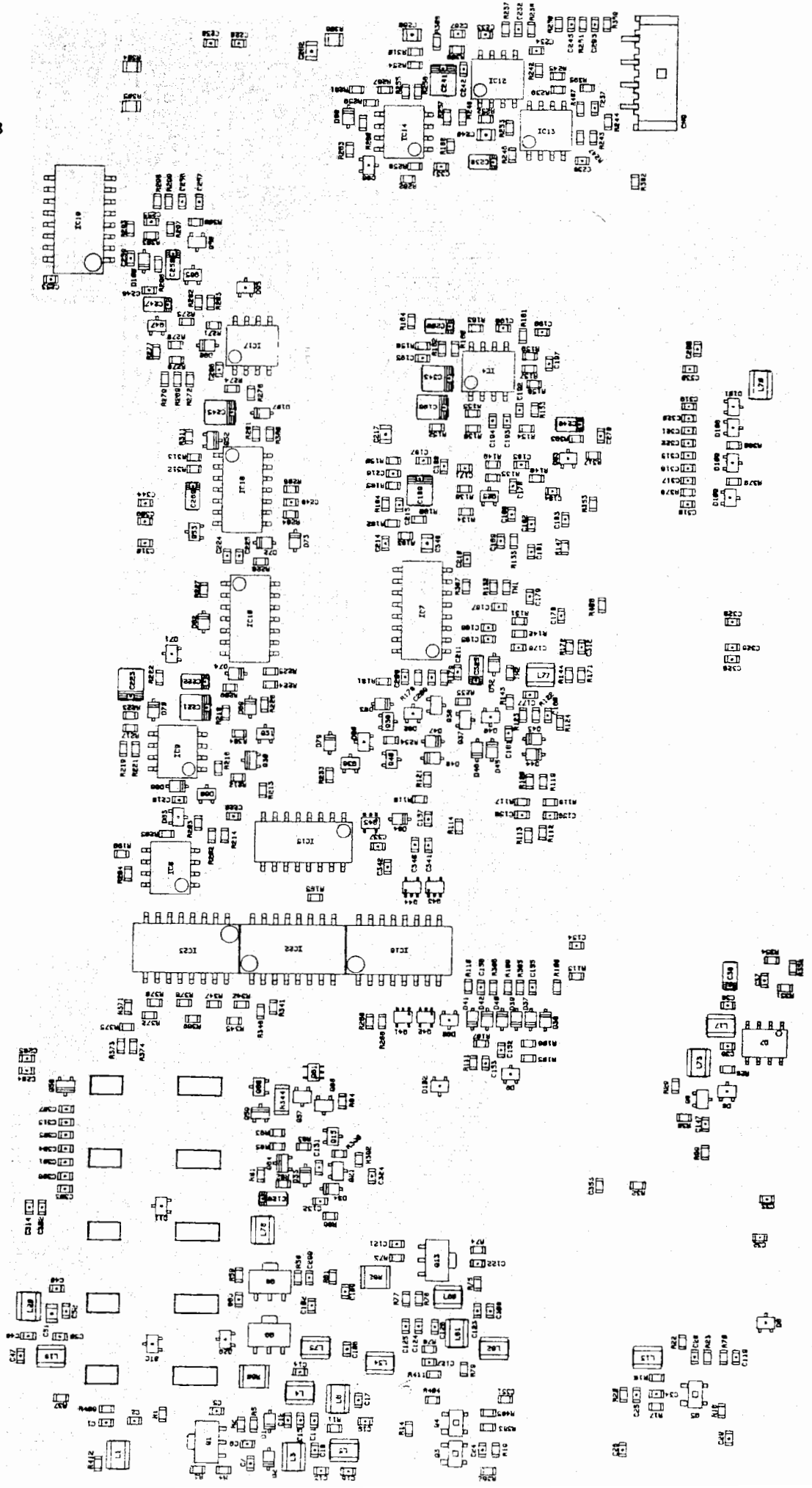

9) PA Unit Side A

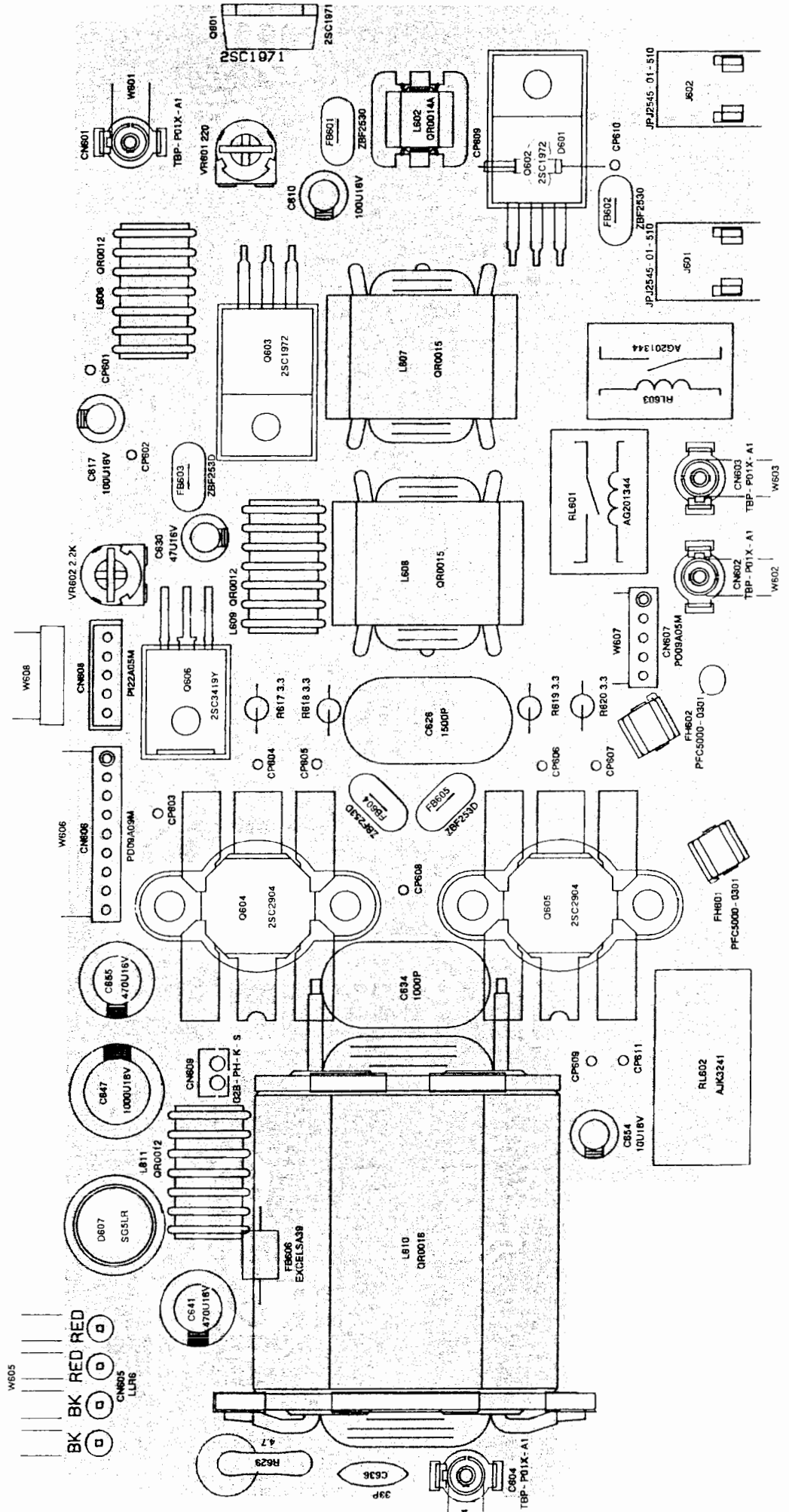

10) PA Unit Side B

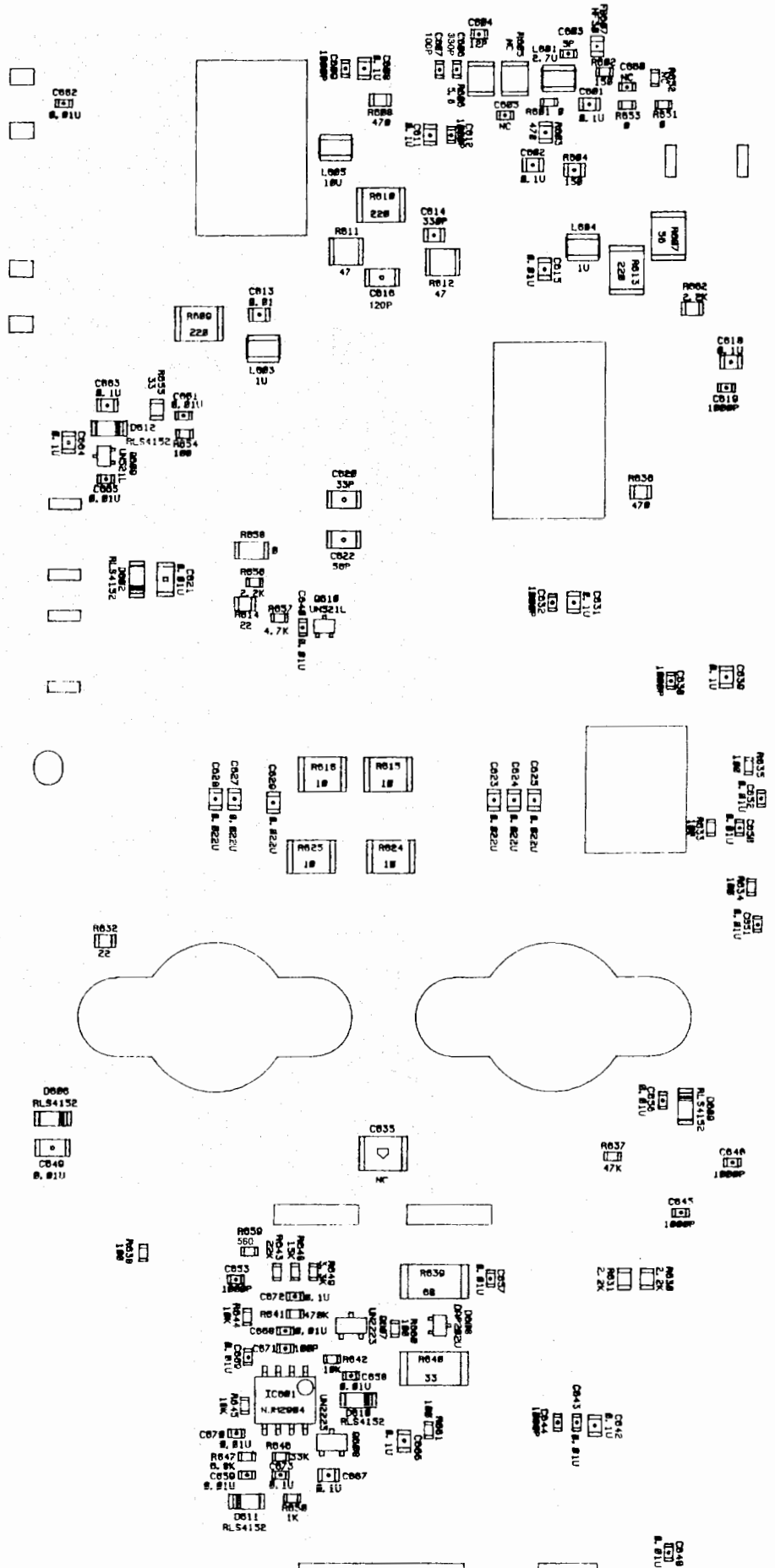

11) Filter Unit Side A

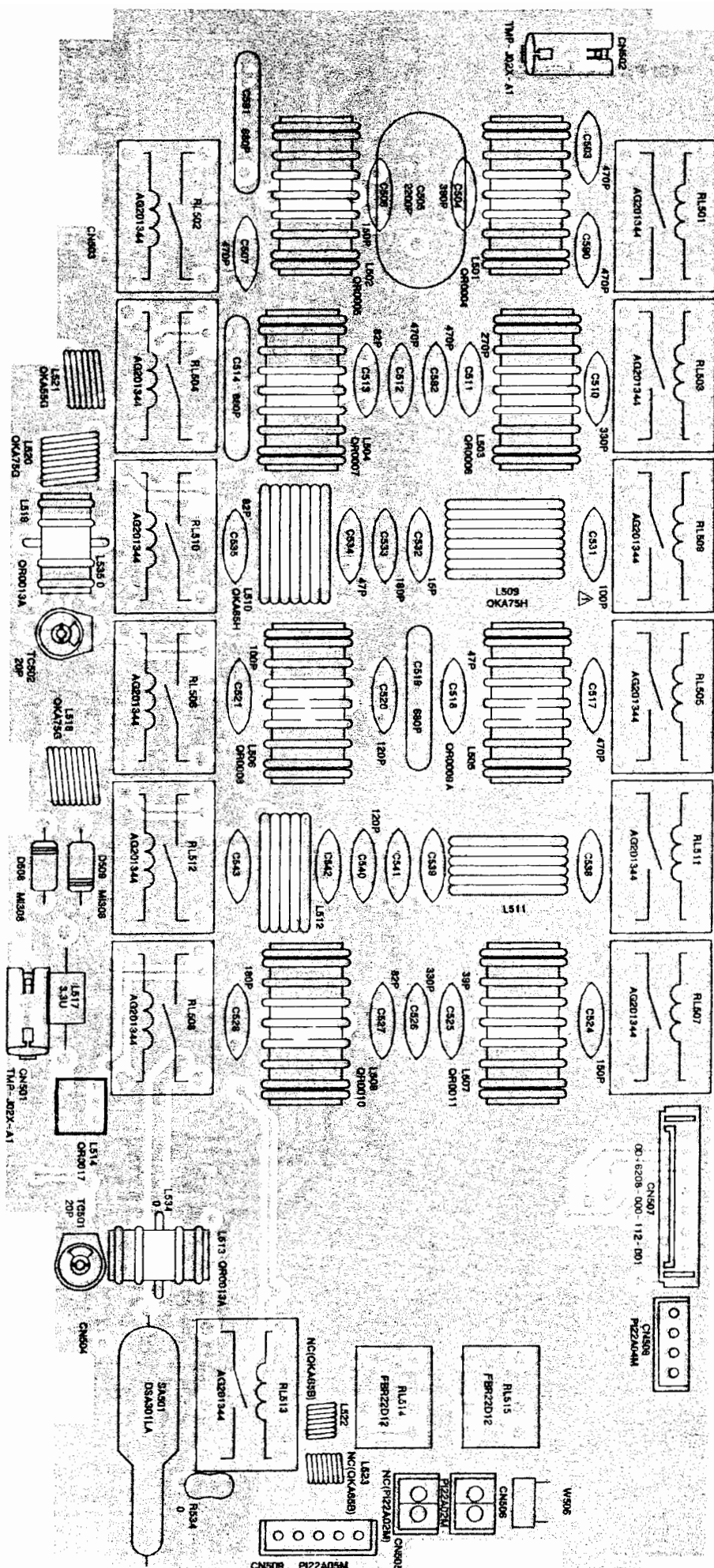

DX707/H	OKA45H	OKA55H	22P	27P	—	22P	56P
L511	L512	C538	C541	C542	C543		

12) Filter Unit Side B

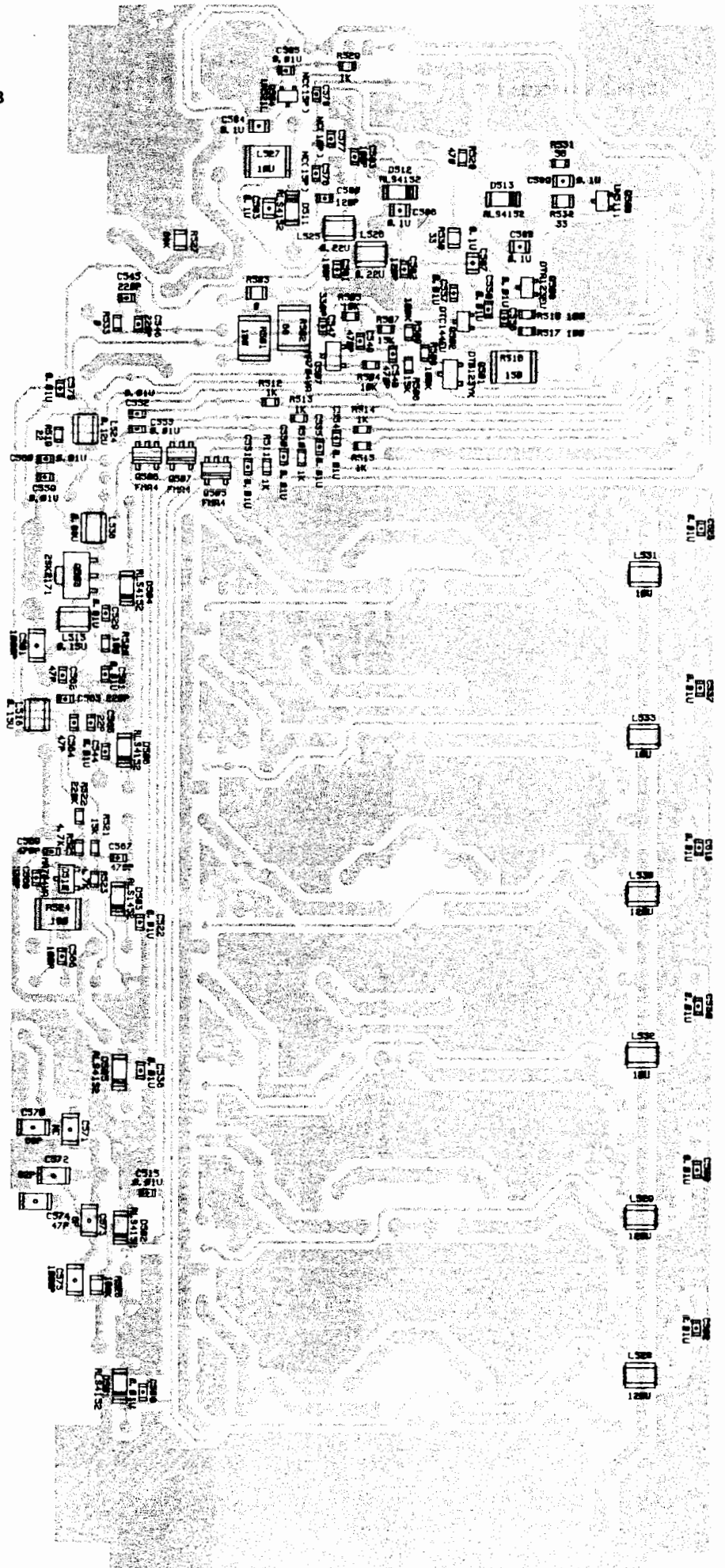



13) PLL Unt Side A

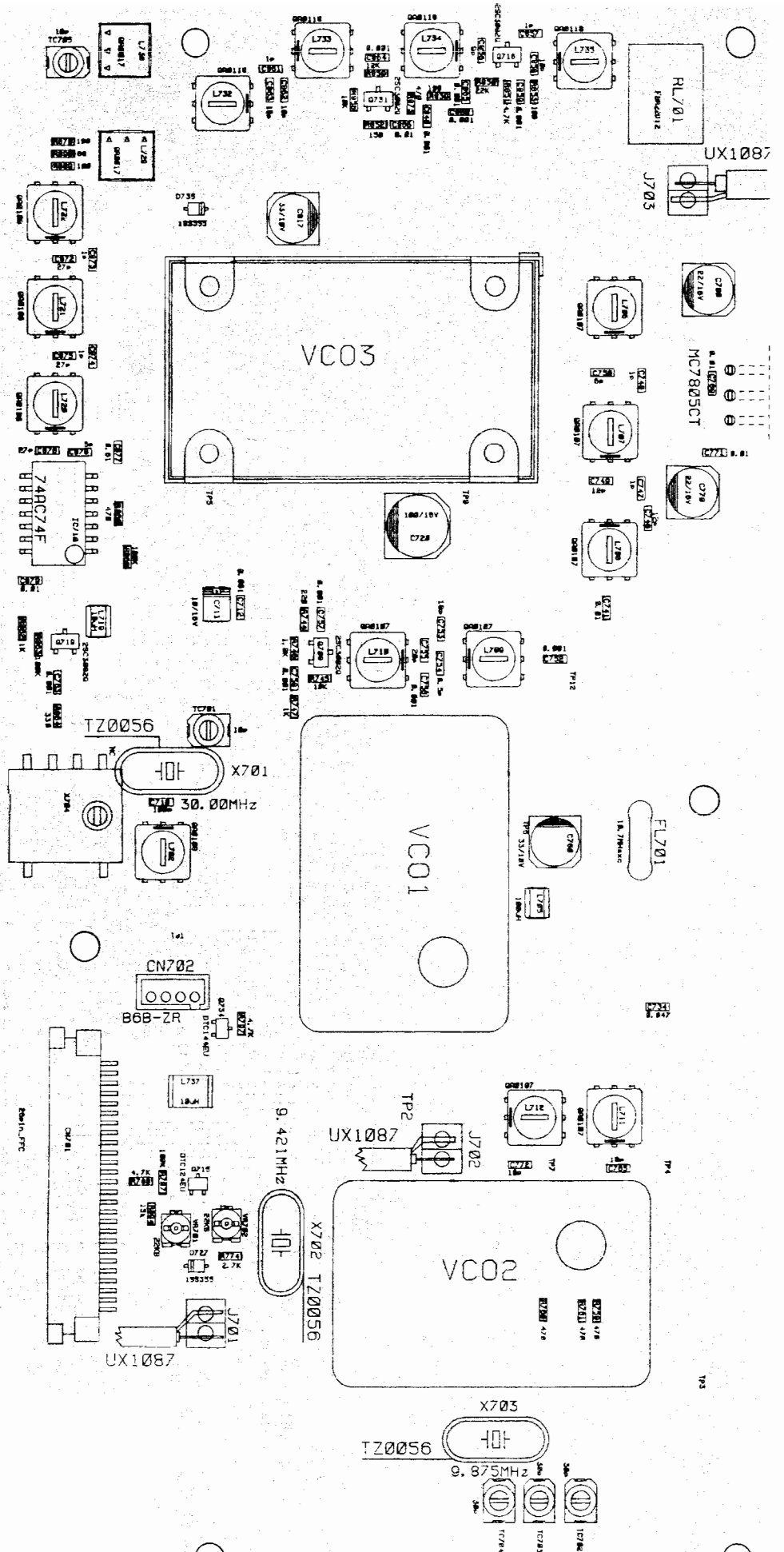

14) PLL Unit Side B

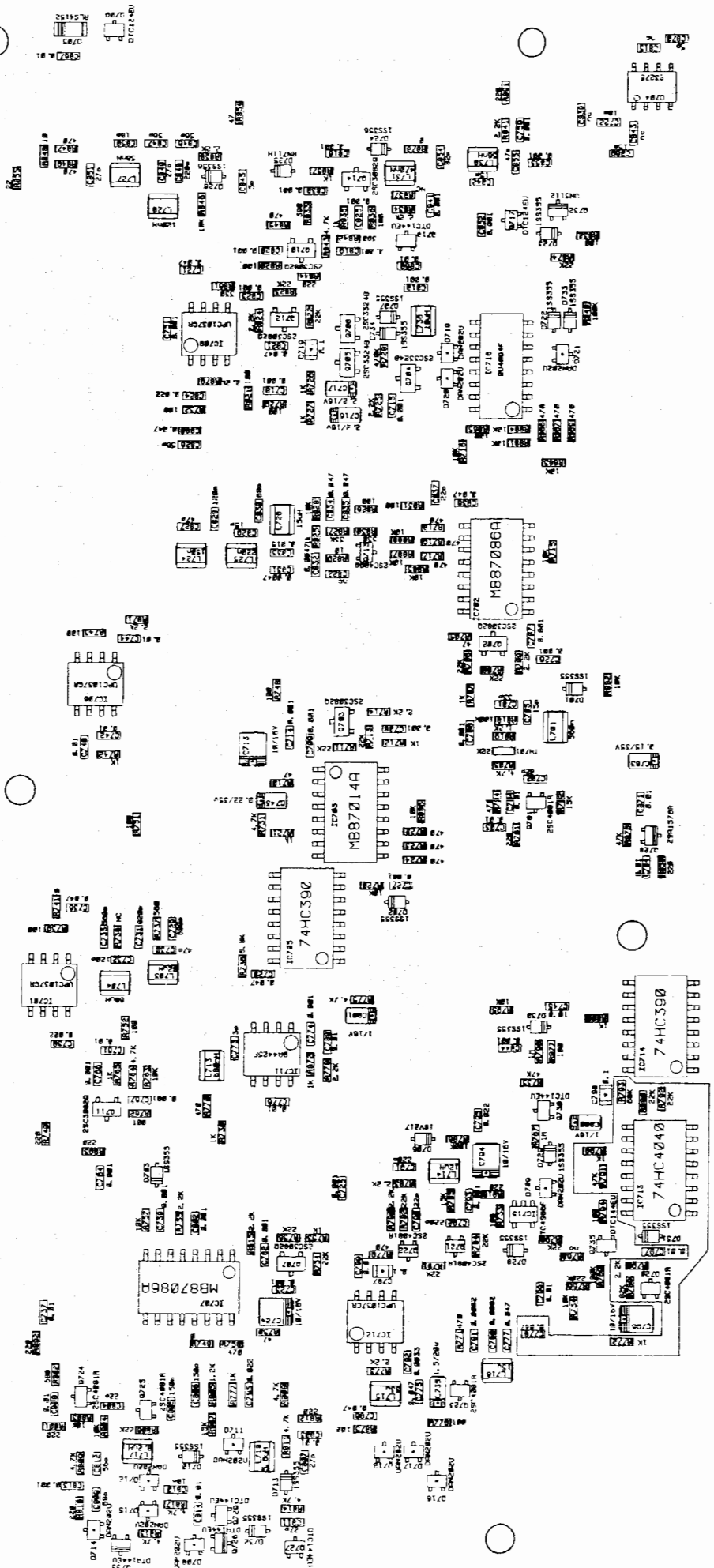

# BLOCK DIAGRAM

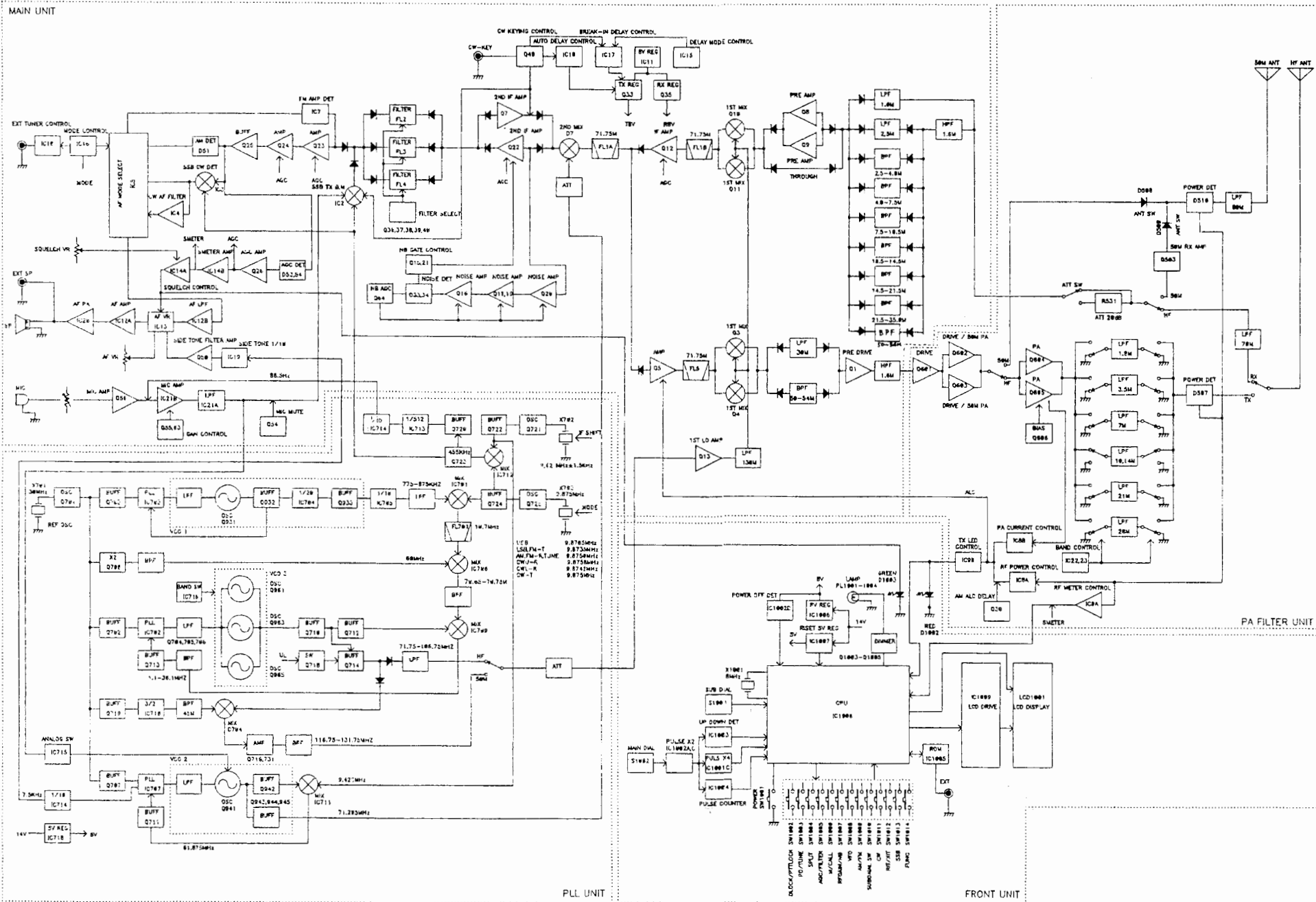

# Exploded View for EDX-1

1) Front View

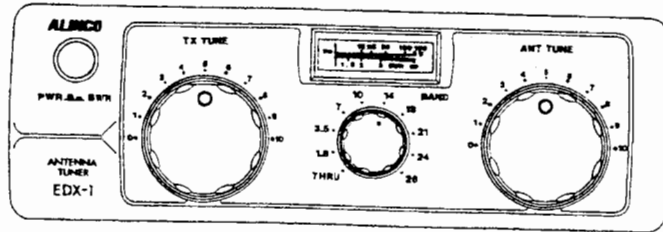

2) Rear View

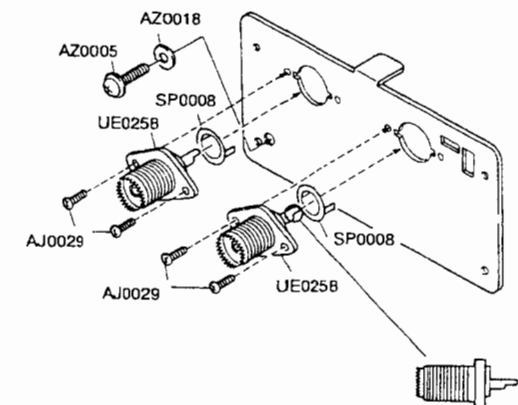
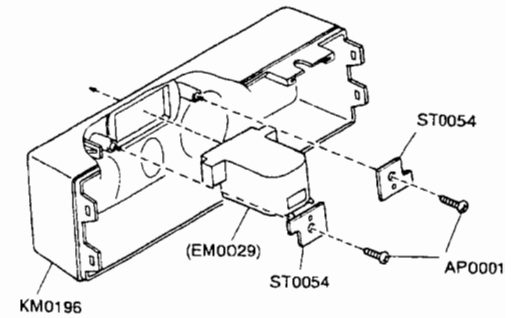
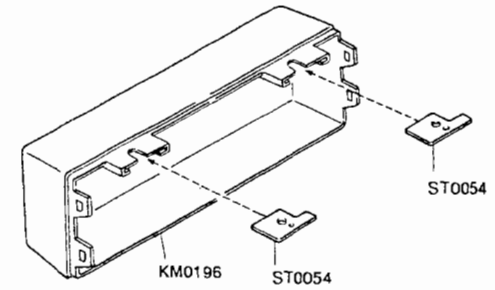
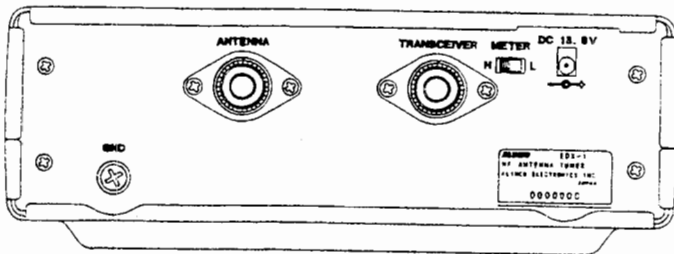

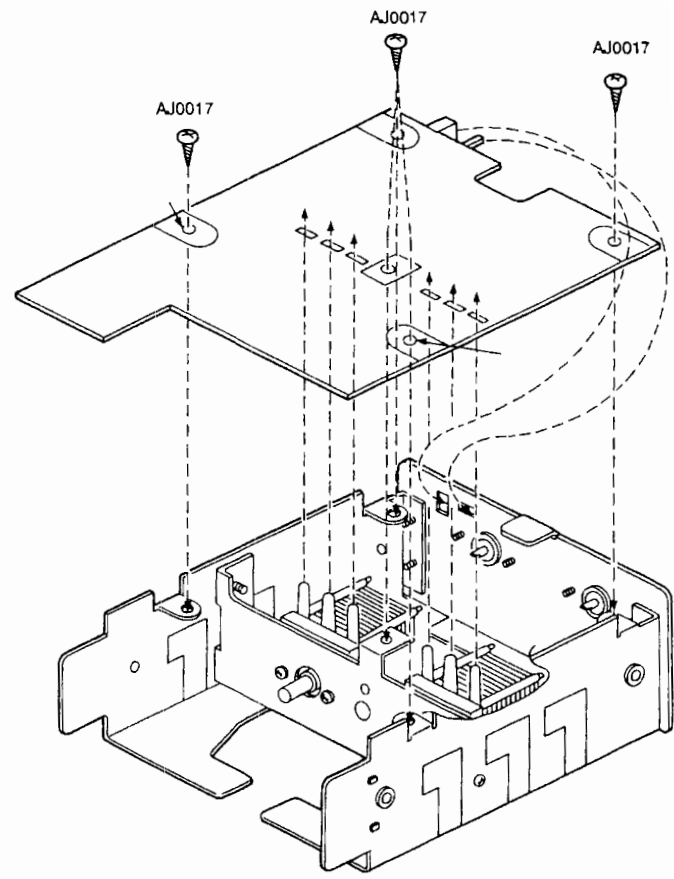
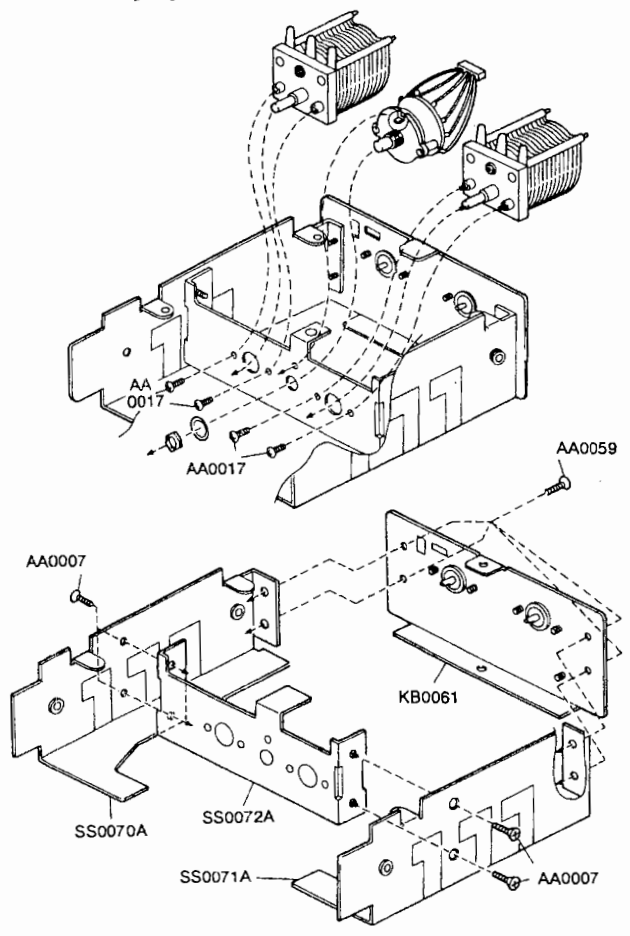
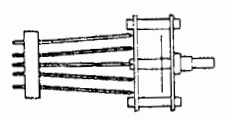
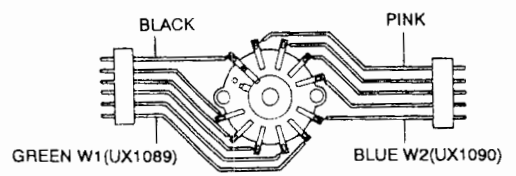

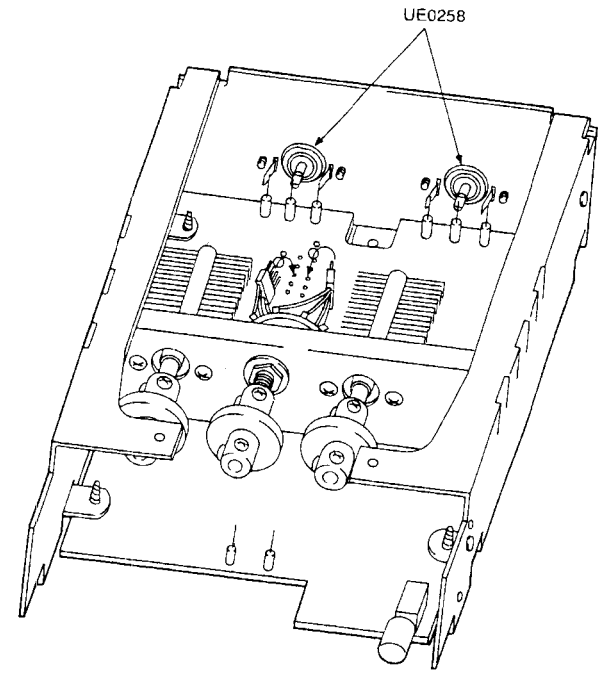
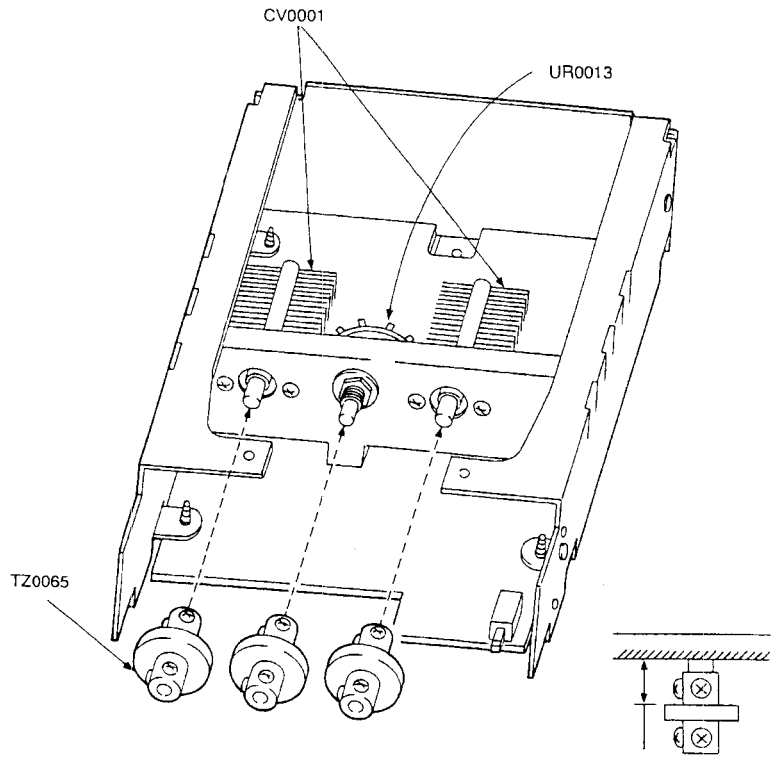

GOOD NO GOOD

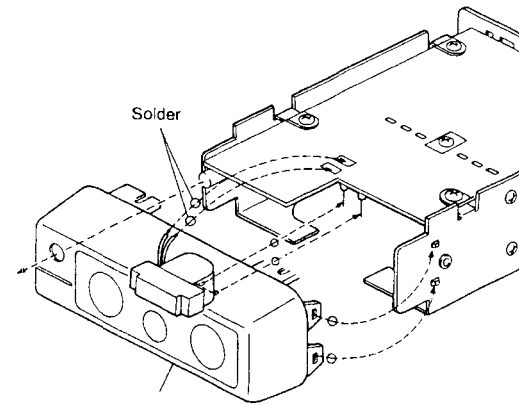
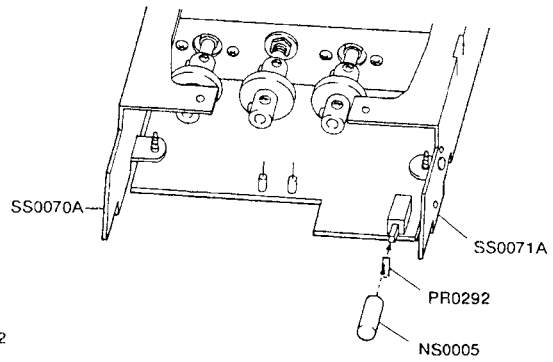
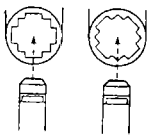

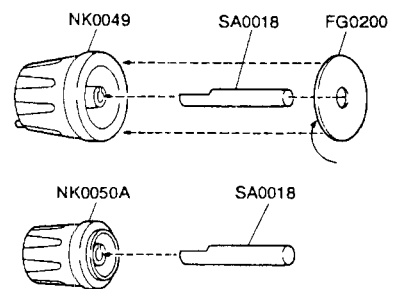
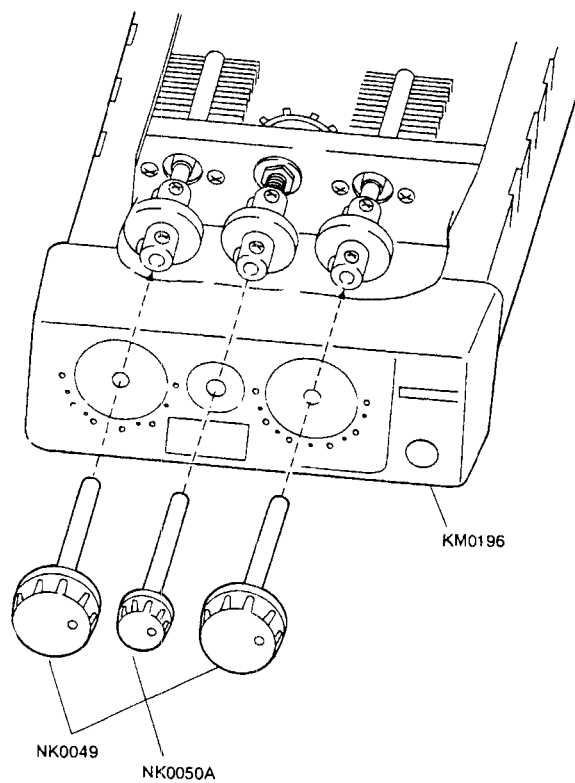
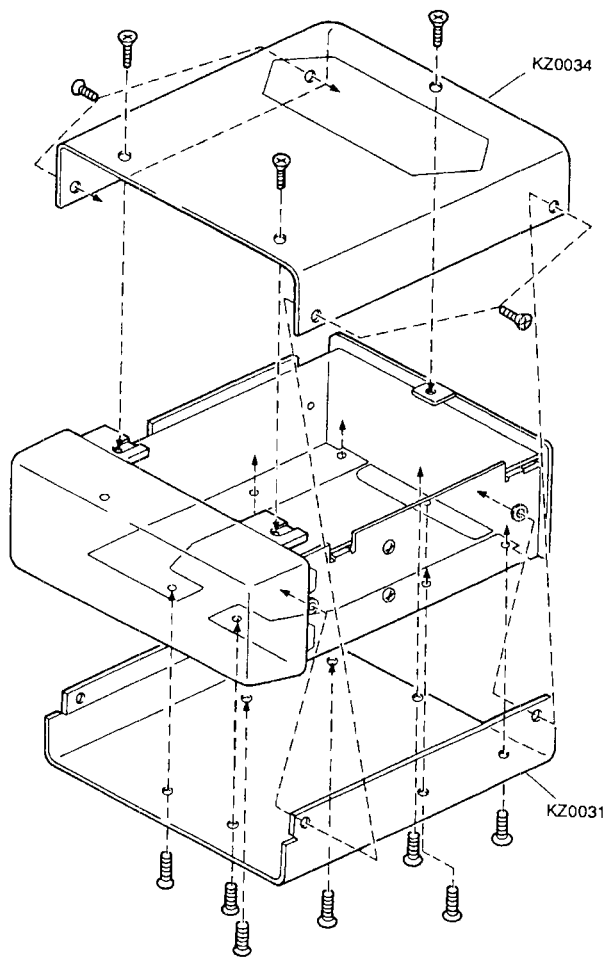

## Parts List for EDX-1

Ref. No.	Parts No.	Parts Name	Loc
Tuner			
C1	CU3047	C1608JB1H103KT-A	1 A
C2	CE0201	16MV10S2 SE1	1 M
C3	CE0201	16MV10S2 SE1	1 M
C4	CU3047	C1608JB1H103KT-A	1 A
C5	CU3027	C1608CH1H221KT-A	1 A
C6	CU3029	C1608JB1H331KT-A	1 A
C7	CU3031	C1608JB1H471KT-A	1 A
C8	CU3031	C1608JB1H471KT-A	1 A
C9	CU3101	C1608JB1C473KT-A	1 A
C10	CU3101	C1608JB1C473KT-A	1 A
C11	CU3101	C1608JB1C473KT-A	1 A
C12	CU3031	C1608JB1H471KT-A	1 A
C13	CU3044	C1608JB1H562KT-A	1 A
C14	CS0060	TMCSA1E474MTR	1 A
C15	CU3047	C1608JB1H103KT-A	1 A
C16	CU3047	C1608JB1H103KT-A	1 A
C17	CU3047	C1608JB1H103KT-A	1 A
C18	CU3047	C1608JB1H103KT-A	1 A
C19	CU3047	C1608JB1H103KT-A	1 A
C20	CU3047	C1608JB1H103KT-A	1 A
C21		NC NC	
C22	CU3047	C1608JB1H103KT-A	1 A
C23	CU3047	C1608JB1H103KT-A	1 A
C24	CU3047	C1608JB1H103KT-A	1 A
C25	CU3047	C1608JB1H103KT-A	1 A
C26	CU3047	C1608JB1H103KT-A	1 A
C27	CU3047	C1608JB1H103KT-A	1 A
C28	CU3030	C1608JB1H391KT-A	1 A
C29	CU3047	C1608JB1H103KT-A	1 A
C30	CU3047	C1608JB1H103KT-A	1 A
C31	CS0060	TMCSA1E474MTR	1 A
D1	XD0273	RLS-93 TE11	1 A
D2	XD0297	MA8100 TX	1 A
D3	XD0127	MA704WA TX	1 A
D4	XD0273	RLS-93 TE11	1 A
D5	XD0273	RLS-93 TE11	1 A
IC1	XA0224	NJM2904M-T1 JRC	1 A
IC2	XA0224	NJM2904M-T1 JRC	1 A
J1	UJ0033	HEC2781-010520	1 M
JP1	RD1013	JPW02 R01	1 H
JP2	RD1013	JPW02 R01	1 H
JP3	RD1013	JPW02 R01	1 H

Ref. No.	Parts No.	Parts Name	Loc
JP4	RD1013	JPW02 R01	1 H
JP5	RD1013	JPW02 R01	1 H
JP6	RD1013	JPW02 R01	1 H
JP7	RD1013	JPW02 R01	1 H
JP8	RD1013	JPW02 R01	1 H
JP9	RD1013	JPW02 R01	1 H
JP10		NC NC	
JP11	RK1107	ERJ8GEY0R00V	1 A
L1	RD1013	JPW02 R01	1 H
L2	QR0013A	Toroidal Coil QR0013A	1 H
L3	OK8002	COIL OK8002	1 H
L4	QR0019	Toroidal Coil QR0019	1 H
L5	QR0020	Toroidal Coil QR0020	1 H
L6	GC0048	NL322522T-100J	1 A
O1	XT0113	2SC2873Y TE12L	1 A
O2	XU0148	DTC144EU T106	1 A
O3	XU0148	DTC144EU T106	1 A
R1	RK4087	ERJ14YJ151V	1 A
R2	RD0001	ERD S2TJ 100	1 M
R3	RK4029	ERJ-12YJ181H	1 A
R4	RK4024	ERJ-12YJ680H	1 A
R5	RK3050	ERJ3GSYJ103V	1 A
R6	RK3050	ERJ3GSYJ103V	1 A
R7	RK3052	ERJ3GSYJ153V	1 A
R8	RK3052	ERJ3GSYJ153V	1 A
R9	RK3060	ERJ3GSYJ683V	1 A
R10	RK3062	ERJ3GSYJ104V	1 A
R11	RK3062	ERJ3GSYJ104V	1 A
R12	RK3062	ERJ3GSYJ104V	1 A
R13	RK3050	ERJ3GSYJ103V	1 A
R14	RK3050	ERJ3GSYJ103V	1 A
R15	RK3063	ERJ3GSYJ124V	1 A
R16	RK3048	ERJ3GSYJ682V	1 A
R17	RK3050	ERJ3GSYJ103V	1 A
R18	RK3054	ERJ3GSYJ223V	1 A
R19	RK3048	ERJ3GSYJ682V	1 A
R20	RK3050	ERJ3GSYJ103V	1 A
R21	RK3050	ERJ3GSYJ103V	1 A
R22	RK3057	ERJ3GSYJ393V	1 A
R23	RK3074	ERJ3GSYJ105V	1 A
R24	RK3057	ERJ3GSYJ393V	1 A
R25	RK3057	ERJ3GSYJ393V	1 A
R26	RK3062	ERJ3GSYJ104V	1 A

Ref. No.	Parts No.	Parts Name	Loc
R27	RK3050	ERJ3GSYJ103V	1 A
R28	RK0001	ERJ6GEYJ100V	1 A
R29	RK3026	ERJ3GSYJ101V	1 A
R30	RK3070	ERJ3GSYJ474V	1 A
R31	RK3026	ERJ3GSYJ101V	1 A
RL1	UL0	SVR-12	1 M
RL2	UL0015	SVR-12	1 M
SW1	UQ0015	SPPJ22727A	1 M
SW2	UR0013	SRRY101AN-R15	1 H
SW3	US0020	ESD1522209	1 M
TC1	CT0036	ECV1ZW20X64T	1 M
VC1	CV0001	UV44B 300P	1 H
VC2	CV0001	UV44B 300P	1 H
VR1	RH0105	EVMIYSX50BY4	1 A
VR2	RH0106	EVMIYSX50B04	1 A
W1	UX1089	Wires EDX-1 1	1 H
W2	UX1090	Wires EDX-1 2	1 H
W3	UX1091	Wires EDX-1 3	1 H
W4	UX1091	Wires EDX-1 3	1 H
UP0291		EDX-1 PC Board	1 T

Ref. No.	Parts No.	Parts Name	Loc
----------	-----------	------------	-----



**Connection Example**

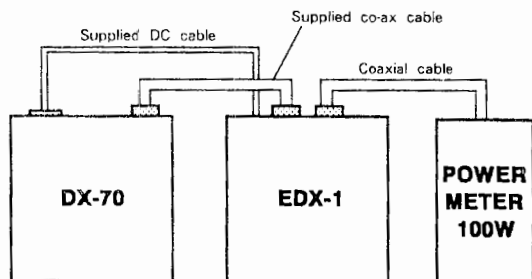

**Required Test Equipment for EDX-1**

TX ON	BAND	SWR	METER	TX TUNE	ANT TUNE	METER READING	UNIT
14.1MHz 100W	1.8	ON	H	10	10	∞	SWR
14.1MHz 100W	THRU	OFF	H	-	-	100W	PWR
14.1MHz 10W	THRU	OFF	L	-	-	10W (100W on scale)	PWR
1.9MHz 100W	1.8	ON	H	4	4	1.5max.	SWR
3.6MHz 100W	3.5	ON	H	7	7	1.5max.	SWR
7.1MHz 100W	7	ON	H	6	6	1.5max.	SWR
10.1MHz 100W	10	ON	H	7.5	7.5	1.5max.	SWR
14.1MHz 100W	14	ON	H	8	8	1.5max.	SWR
18.1MHz 100W	18	ON	H	8.5	8.5	1.5max.	SWR
21.1MHz 100W	21	ON	H	9	9	1.5max.	SWR
24.9MHz 100W	24	ON	H	9	9	1.5max.	SWR
28.1MHz 100W	28	ON	H	9	9	1.5max.	SWR

**Adjustment Point**

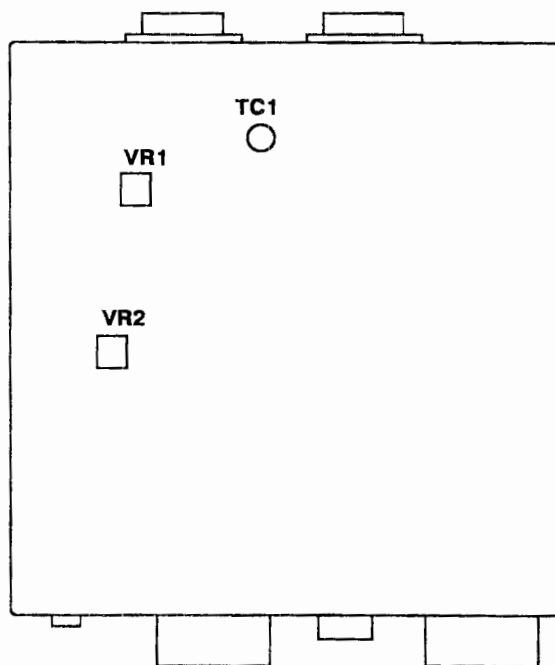

**Adjustment for EDX-1**

DX-70 TX FREQ. 14.1MHz TX POWER 100W						
BAND	SWR	METER	TX TUNE	ANT TUNE	ADJUST POINT	METER READING
THRU	ON	H	-	-	TC 1	MIN
1.8	ON	H	10	10	VR 2	∞
THRU	OFF	H	-	-	VR1	100W

# PC Bord View for EDX-1

Side A

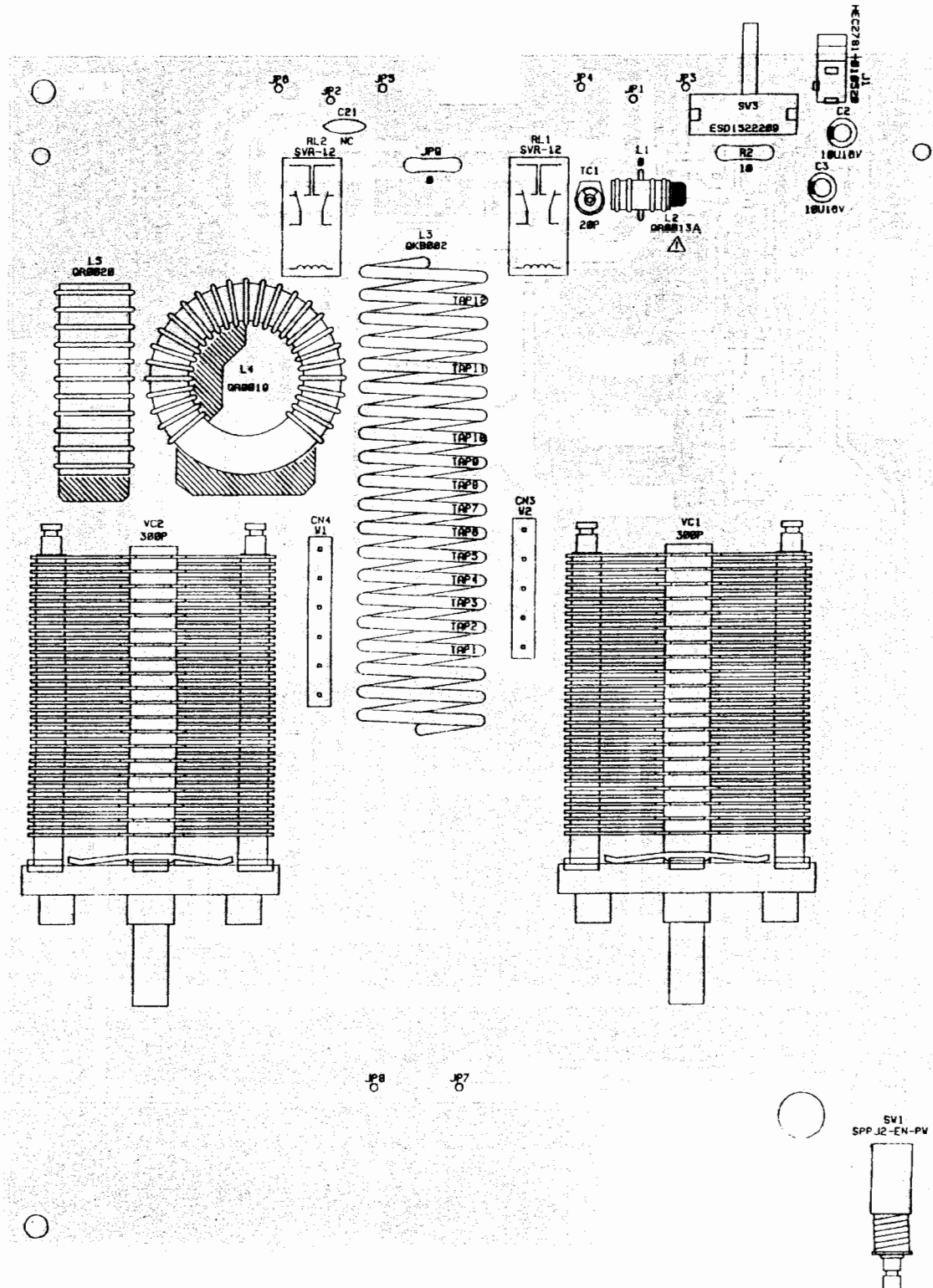

Side B

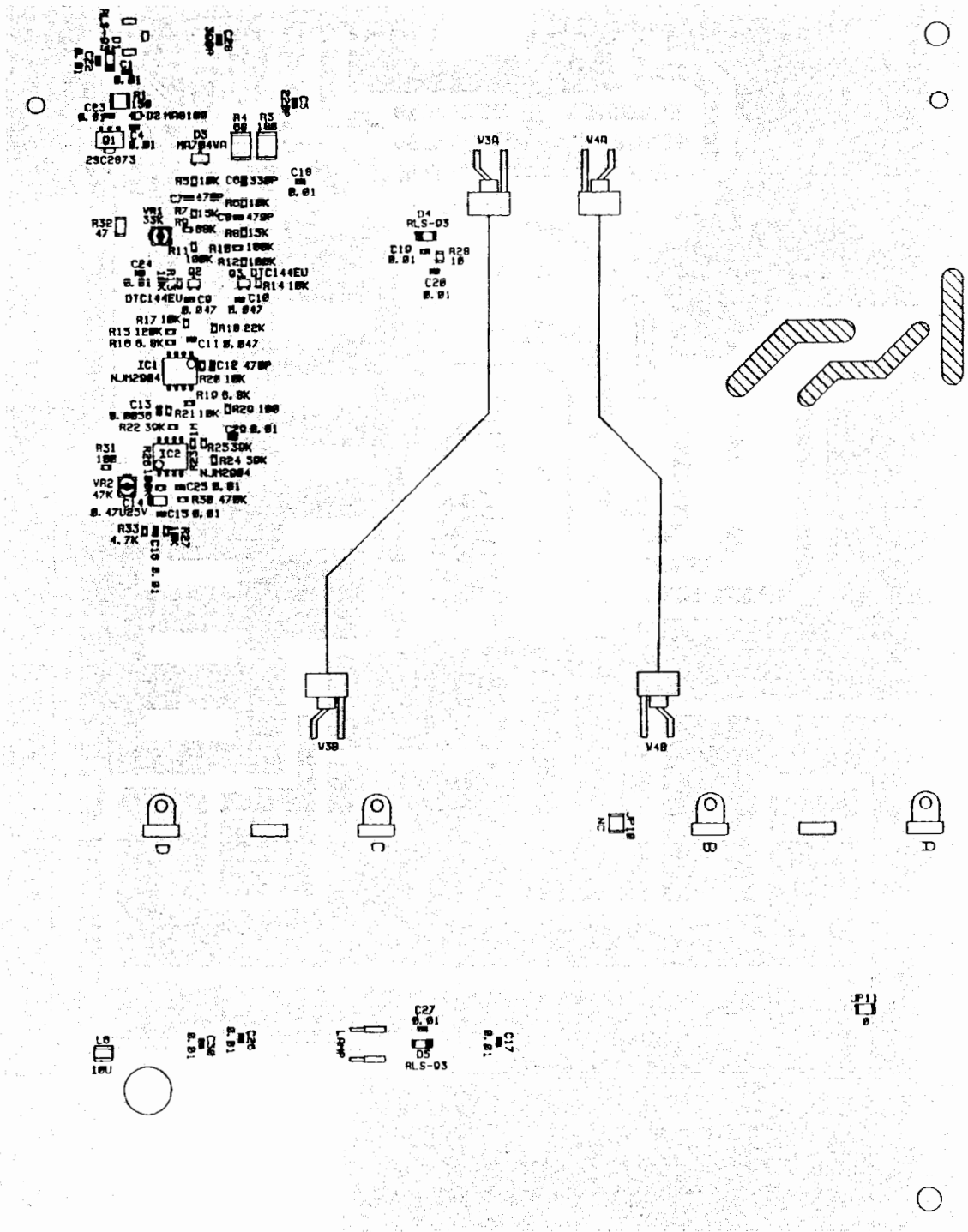

# Schematic Diagram for EDX-1

