

# (tr)uSDX – 5-Band / Multimode QRP Transceiver

efficient Class E PA and Supports CW/LSB/USB and AM/FM. It covers by default 80/60/40/30/20m (alternative Filter Setups possible)



The (tr)uSDX is a 5-Band / Multimode QRP Transceiver in Pocket Format (90x60x30mm – 140g). It features a highly efficient Class E PA and Supports CW/LSB/USB and AM/FM. It covers by default 80/60/40/30/20m (alternative Filter Setups possible)

It is supplied with an OLED Display, onboard Mic, (tiny) onboard speaker and for improvised QSO onboard PTT Key can be used as emergency CW Key.

Further on, the (tr)uSDX has a (Micro)USB CAT and Programming Interface, and while it produces typically 5W @ 13.8V Power Supply, it can create 0,5W Output from 5V USB Supply alone.

Typically it draws 80mA on RX (with MS5351 – less with SI5351) and 500mA on TX @13.8V and typical 85% PA Efficiency.

It is supplied with OnBoard SWR Bridge and Voltage/Current measurement Hardware, to help in tuning and operation.

## General Overview

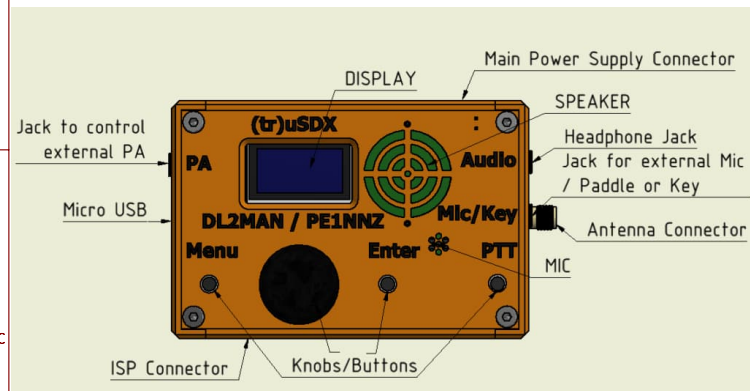

## External Connections

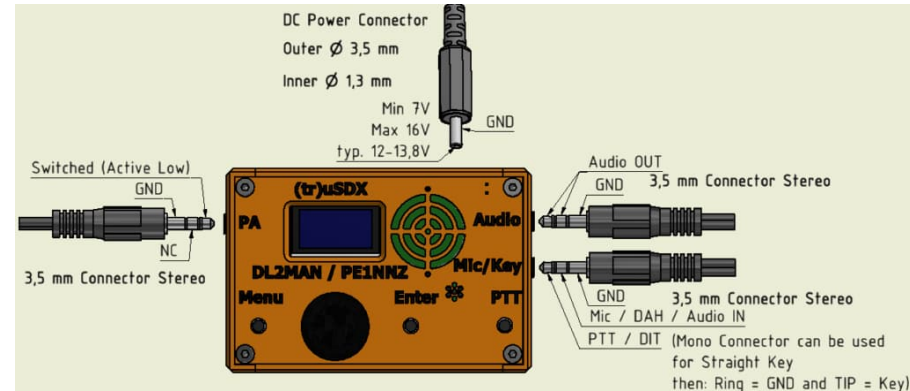

## ISP Connection

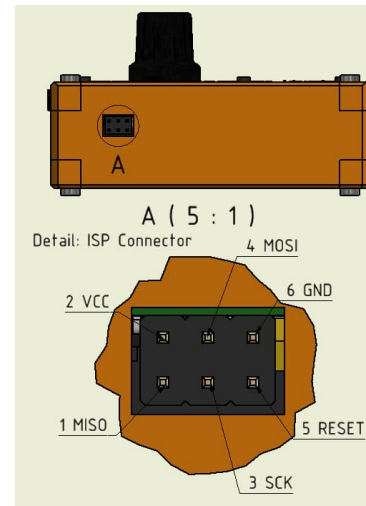

## Programming

### Bootloader

The Bootloader needs to be installed only once, before the Firmware can be installed. Normally, for Group Buy or Kit Buy, the organizer would normally have installed the Bootloader. The Firmware cannot be loaded via the USB port without first installing the Bootloader. Installing the Bootloader requires an ISP programmer. While there are many ISP programmers than can be purchased, an Arduino Uno can be used as an ISP programmer.

More information about loading the Bootloader and using an Arduino Uno can be found here:

<https://dl2man.de/3a-trusdx-bootloader/>

If the Bootloader has been installed according to the instructions at the link above AND the Firmware has not been installed yet, then every time the (tr)uSDX is powered on, an 18 digit hexadecimal number will appear on the display. This hexadecimal number is the 'serial number' which must be written down and kept – once the Firmware is installed, this number will not be displayed anymore unless the EEPROM is erased when the Bootloader is reinstalled. And this number is required in order to download the Firmware from the (tr)uSDX website.

### Firmware

You will need the 18 digit hexadecimal 'serial number' to download the firmware. (see Bootlader instructions). At the time of this writing, the firmware v2.00i and this version will not display the serial number. The only method to retrieve the serial number, is to reinstall the Bootload and wipe the EEPROM.

Your Callsign is optional. Instructions and more information about loading the Firmware can be found at:

Firmware Page: <https://dl2man.de/3b-trusdx-firmware/>

Software updates will be announced in the (tr)uSDX Forum, <https://forum.dl2man.de/>

and provided on the Firmware page for download. An experimental beta, when available, is uploaded here:

Beta Firmware: <https://dl2man.de/wp-content/uploads/2022/01/wp.php/beta.html>

### More Information:

Videos of the build, tuning and other (tr)uSDX information can be found at:  
\* DL2MAN's website: <https://dl2man.de/>  
\* The (TR)uSDX forum: <https://forum.dl2man.de/>  
\* YouTube DL2MAN channel: <https://www.youtube.com/channel/UCqabnQUJwH4K3FJtxbmrIA>

Below are additional sheets that are form the complete set of schematics, a type of table of contents. It is also KiCAD hierarchical links to the other sheets.



(tr)uSDX Main Board v1.0

Page 2: Main board schematic

File: (tr)uSDX\_Main\_Board\_v1-0.kicad\_sch

(tr)uSDX Main Board Parts Layout A v1.0

Page 3: Main board parts layout without copper trace pattern

File: (tr)uSDX\_Main\_Board\_Parts\_Layout\_A\_v1-0.kicad\_sch

(tr)uSDX Parts Main Board Parts Layout B v1.0

Page 4: Main board parts layout with copper trace pattern

File: (tr)uSDX\_Main\_Board\_Parts\_Layout\_B\_v1-0.kicad\_sch

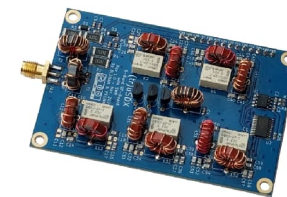

(tr)uSDX RF Board v1.0

Page 5: RF board schematic with 'Lo' band configuration

File: (tr)uSDX\_RF\_Board\_v1-0.kicad\_sch

(tr)uSDX RF Board – Alternate Bands v1.0

Page 6: Alternative 'Classic' band with FDT86256 MOSFET configuration and additional RF filter information

File: (tr)uSDX\_RF\_Board-Alt\_Bands\_v1-0.kicad\_sch

RF Board Parts Layout A v1.0

Page 7: RF board parts layout without copper trace pattern

File: (tr)uSDX\_RF\_Board\_Parts\_Layout\_A\_v1-0.kicad\_sch

RF Board Parts Layout B v1.0

Page 8: RF board parts layout with copper trace pattern

File: (tr)uSDX\_RF\_Board\_Parts\_Layout\_B\_v1-0.kicad\_sch

This Schematic is no modification to the Original work, and approved by DL2MAN/PE1NNZ

Redrawn with notes: KD4SGE & WA4ITD (revision denoted in ( ) after Rev 1.0 below)  
Original Schematic: Rev 1.0 Date: 2021-11-27

DL2MAN & PE1NNZ

Sheet: /  
File: (tr)uSDX\_Main-RF\_Schematics\_v1.0.kicad\_sch

Title: (tr)uSDX Overview and Subsheets

Size: A3 Date: 2022-07-10

KiCad E.D.A. kicad (6.0.5)

Rev: 1.0(m)

Id: 1/8



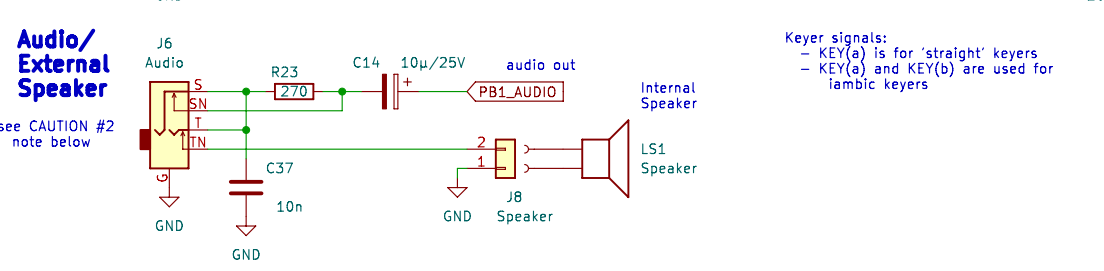
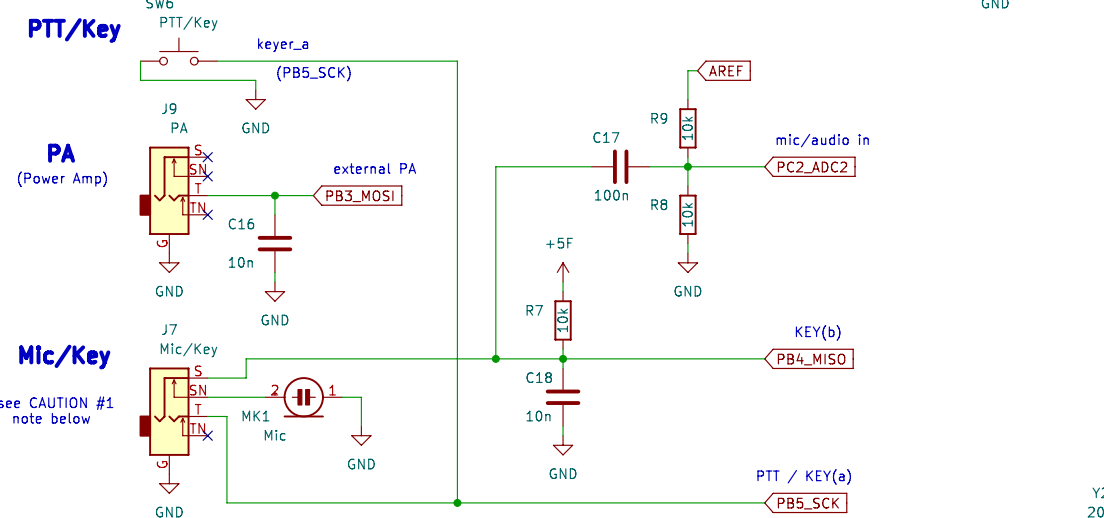
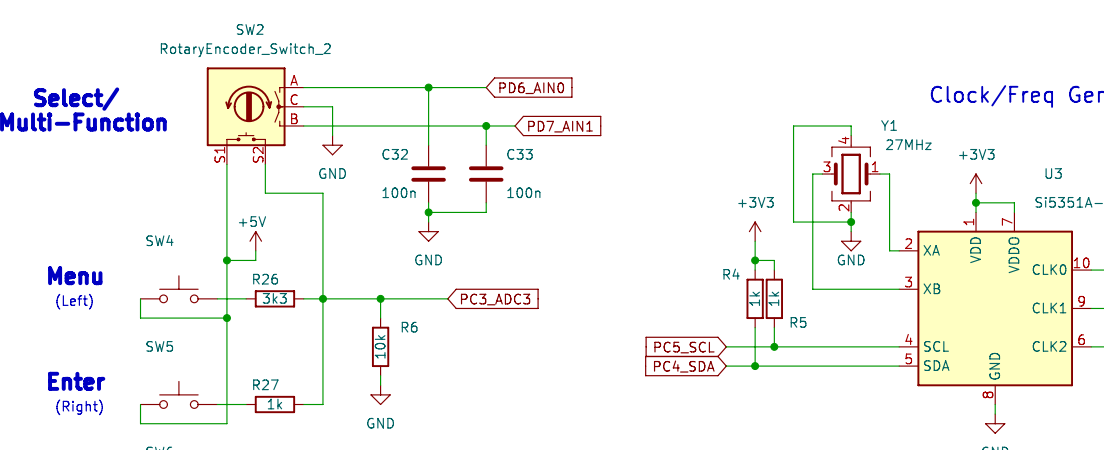
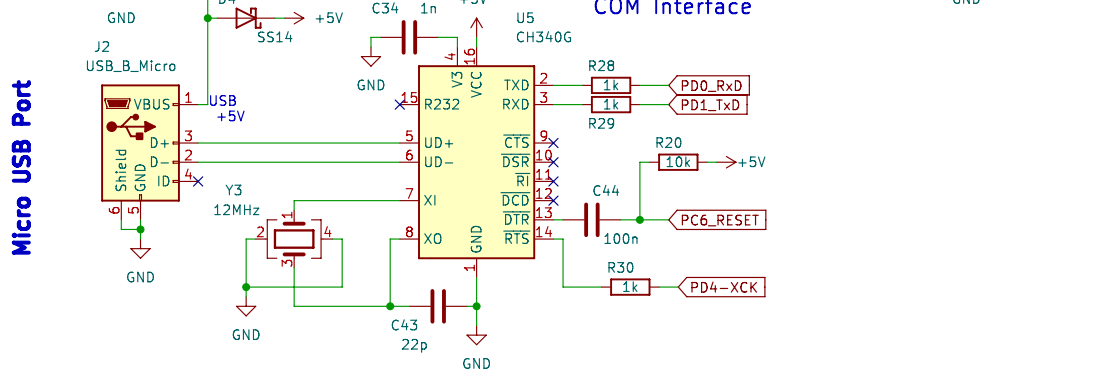
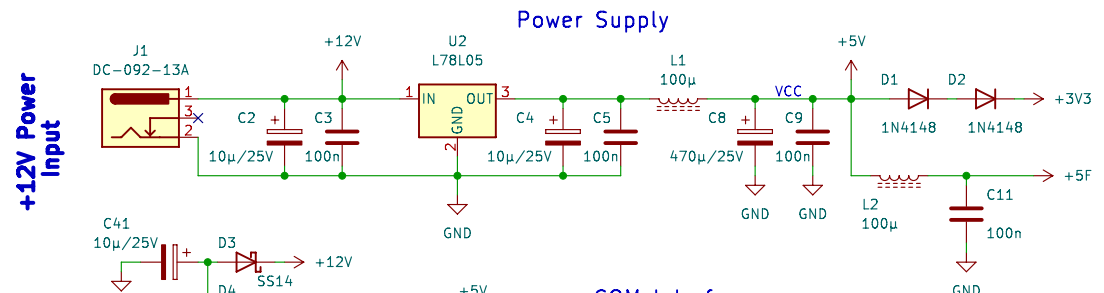

**CAUTION #1:** Be aware, using a mono jack in the Mic/Key port will short the 'ring' contact in the port. In CW mode, this may cause unexpected results if the proper keyer has not been selected in the (tr)uSDX menu. (see Menu 2.6 Keyer Mode)

**CAUTION #2:** Do NOT use a mono jack in the Audio/External Speaker port. The mono jack will short the port's 'ring' contact to ground, which in turn will short the 'tip' contact to ground and the result will be no output audio.

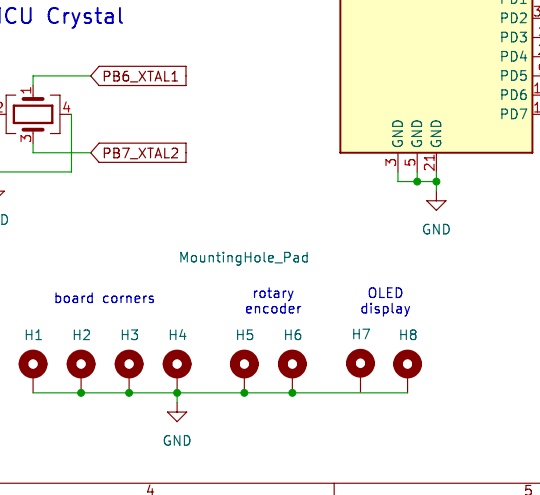
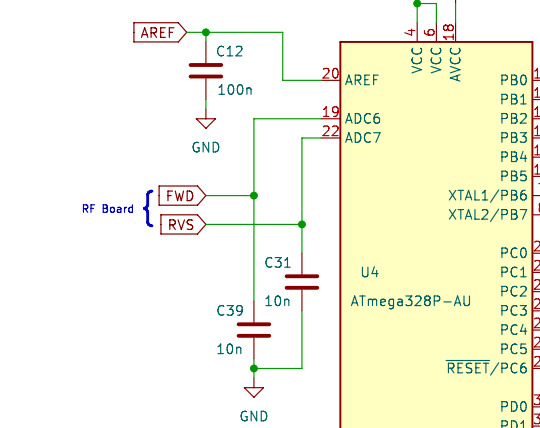
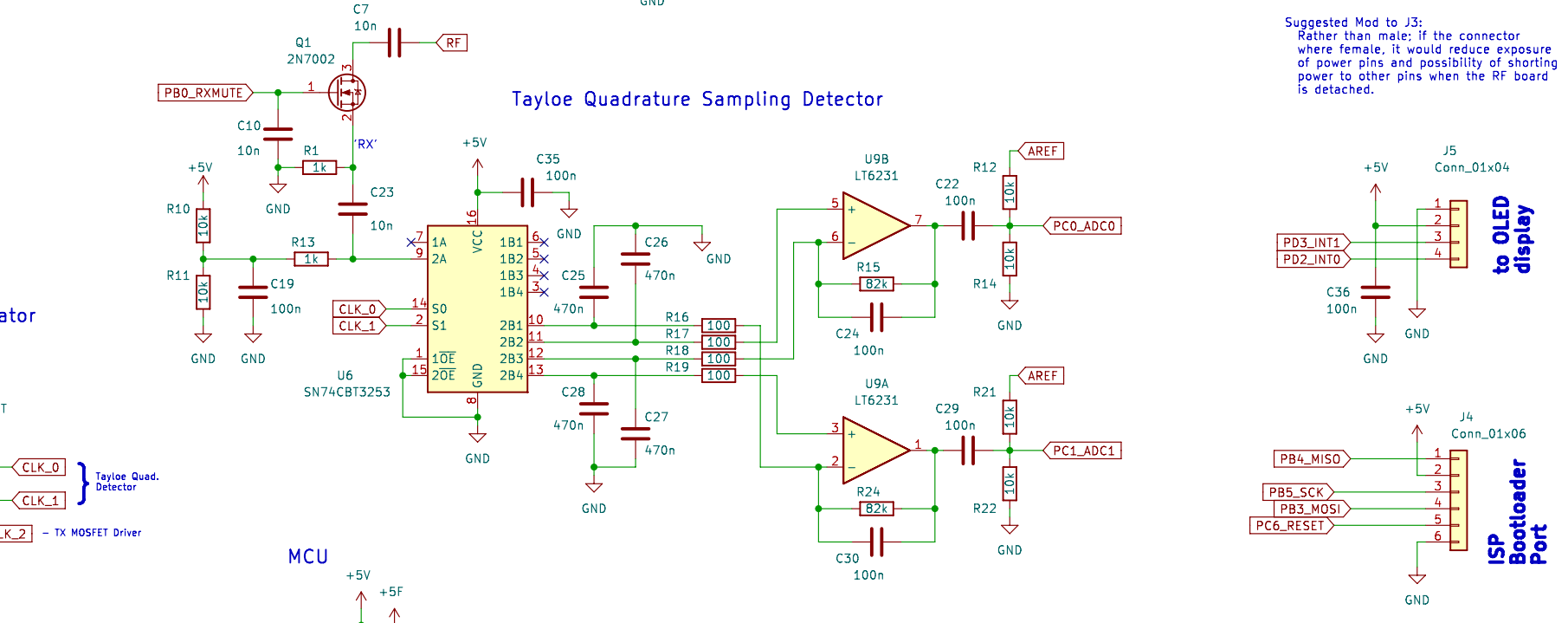
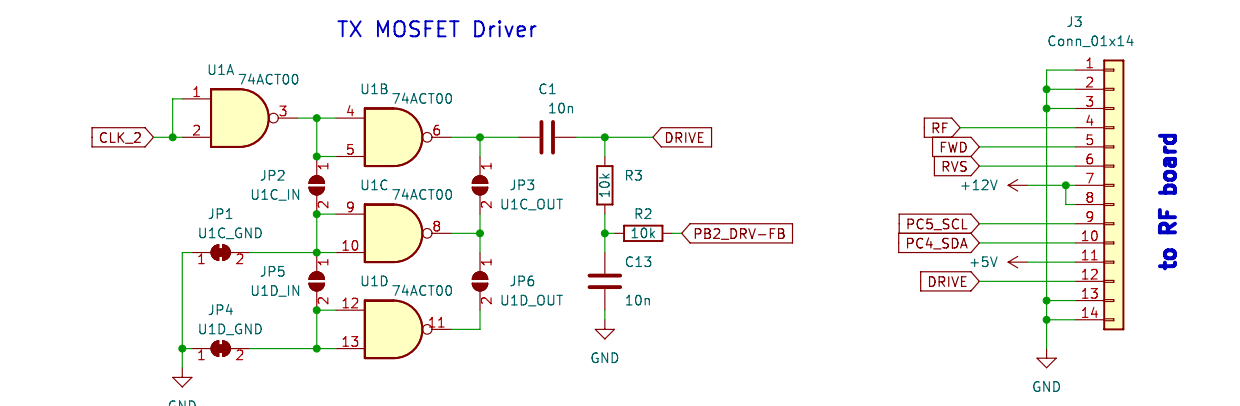
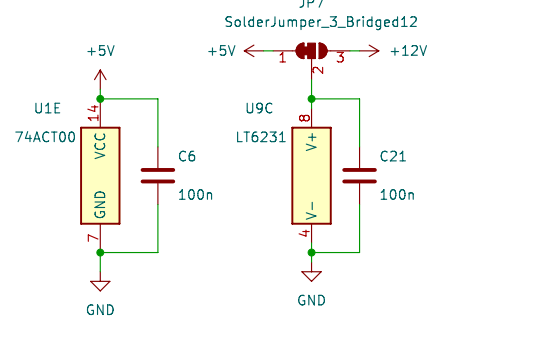

**Suggested Mod to J3:** Rather than male; if the connector were female, it would reduce exposure of power pins and possibility of shorting power to other pins when the RF board is detached.

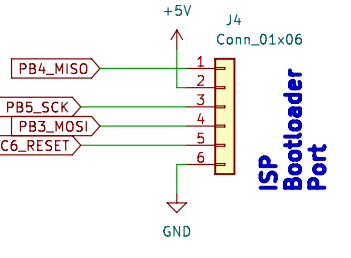
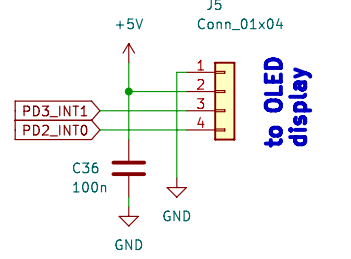

**Optimal Modifications**

Audio Mod (<https://www.youtube.com/watch?v=jImurYa750g>)  
 Original class II ceramic capacitors are known for their piezoelectric effects. They can act like a microphone, causing noise in the circuit.  
 Replacing C25, C26, C27 and C28 with a poly film type can solve most of the noise. There is still some noise in CW mode when using 100Hz/50Hz filters caused by C22 and C29.

**More Information:**

Videos of the build, tuning and other (tr)uSDX information can be found at:  
 \* DL2MAN's website: <https://dl2man.de/>  
 \* The (TR)uSDX forum: <https://forum.dl2man.de/>  
 \* YouTube DL2MAN channel: <https://www.youtube.com/channel/UCqabnQUUjwH4K3FJtxbmlRA>

**A few reasons for redrawing the schematic:**

- Mainly to improve clarity and aid in troubleshooting by:
  - \* Combining parts into functional groups reducing the number of global labels used. A few label names were also modified for clarity of function. One or two were added as a result of grouping parts. This also makes it easier to better understand the design and functional blocks of the (tr)uSDX.
  - \* Power and grounds were changed from 'global labels' to 'power' labels. This helps separate power distribution from signal distribution; making it easier to follow the signal paths.
  - \* The ATmega328P symbol was modified to show the three hidden power pins. This can be relevant as the ATmega328PB (note the 'PB'), version changes two of the pins to signal pins.
  - \* Doing a design, schematic and pcb is a lot of work. It is even more work to go back to revise and clean up things. Thanks to DL2MAN & PE1NNZ done to bring this project to reality. So, we thought this would assist and contribute to the (tr)uSDX project and the Amateur Radio community.

This Schematic is no modification to the Original work, and approved by DL2MAN/PE1NNZ

Redrawn with notes: KD4SGE & WA4ITD (revision denoted in ( ) after Rev 1.0 below)  
 Original Schematic: Rev 1.0 Date: 2021-11-27

<b>DL2MAN &amp; PE1NNZ</b>		
Sheet: (tr)uSDX_Main Board v1.0/ File: (tr)uSDX_Main Board_v1-0.kicad_sch		
<b>Title: (tr)uSDX Main Board</b>	Size: A3	Date: 2022-07-10
KiCad E.D.A. kicad (6.0.5)		Rev: 1.0(m) Id: 2/8



# Top (Front)

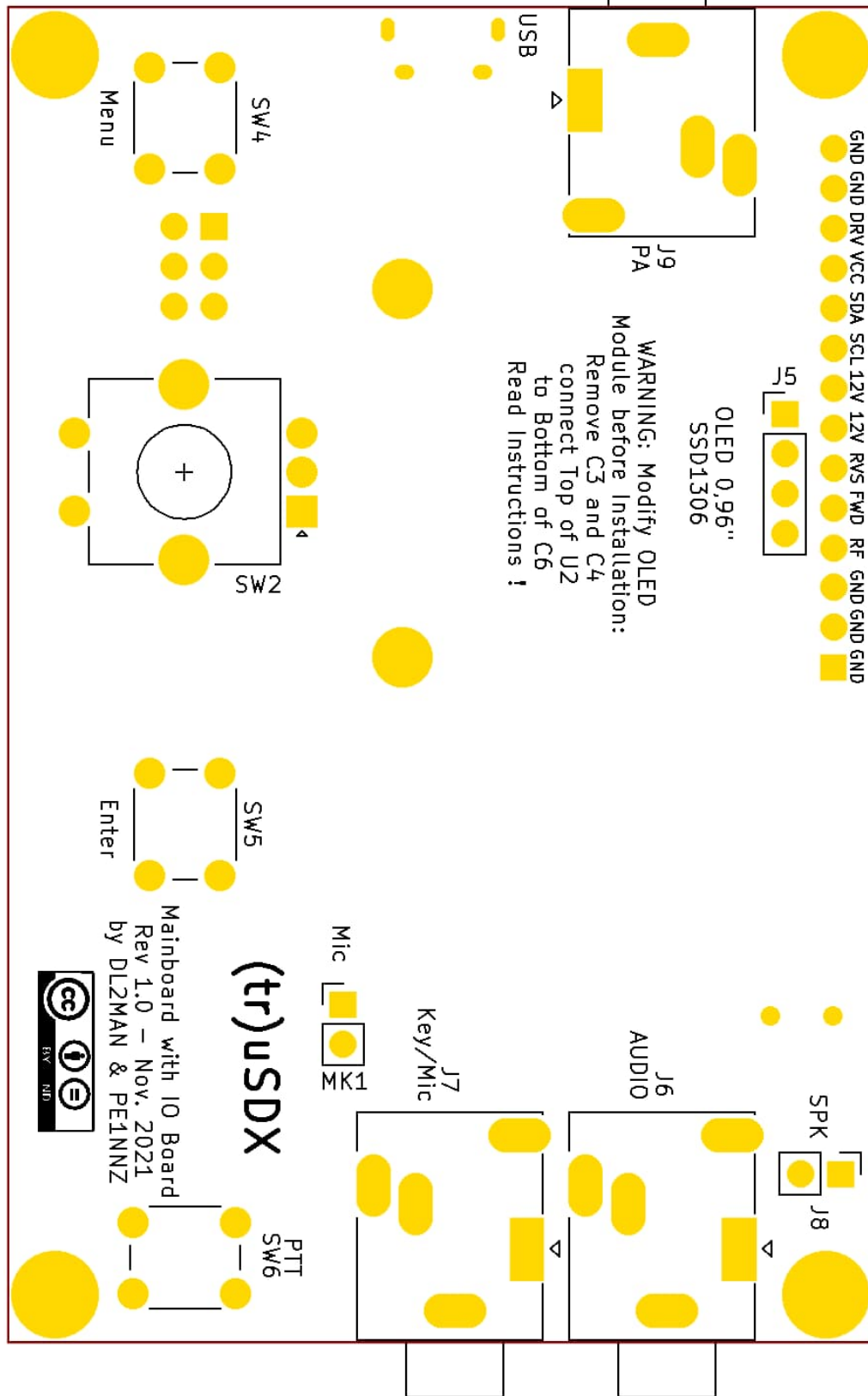

# Bottom (Back)

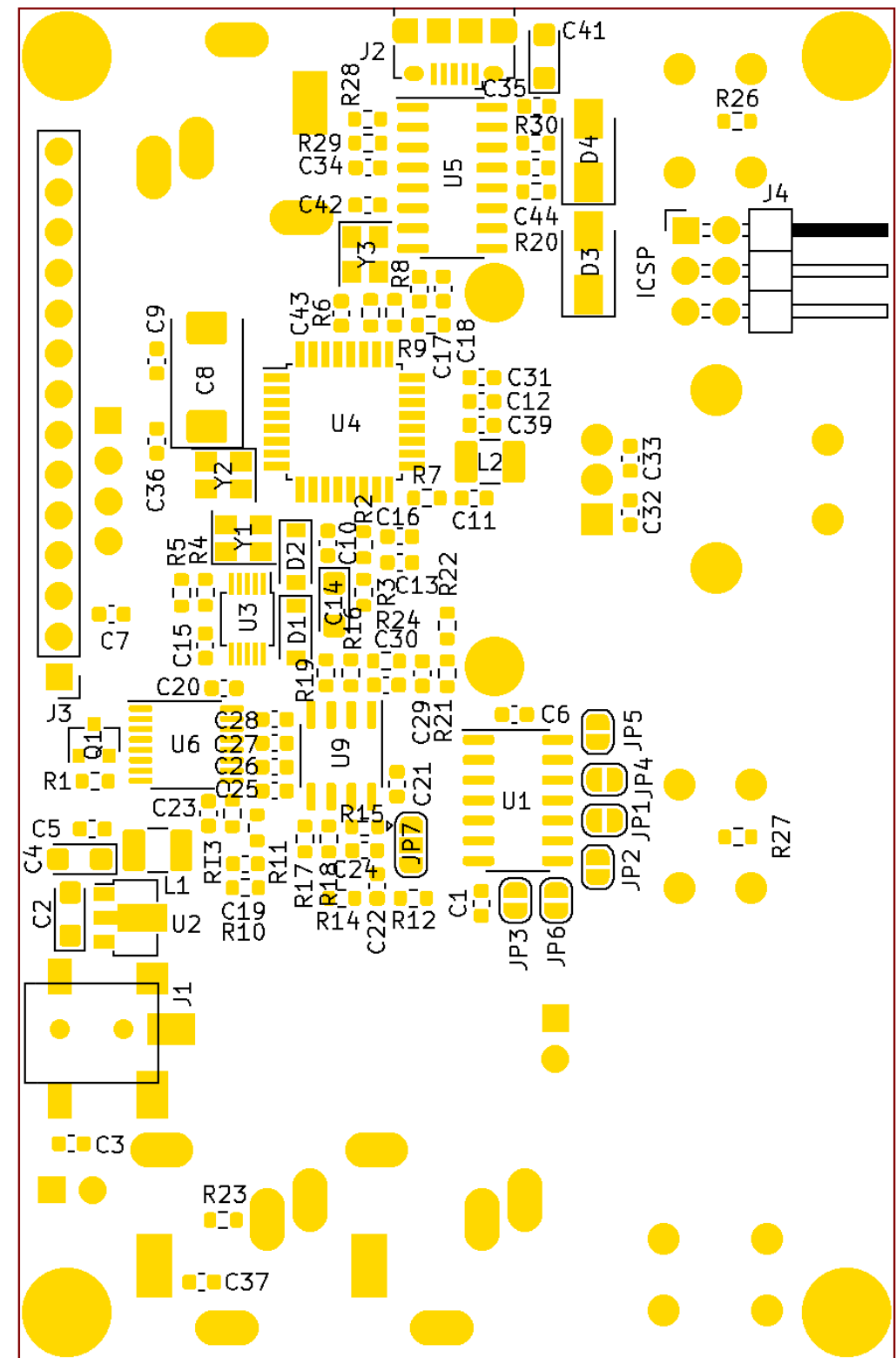

Main Board Parts Layout without copper trace pattern

This Schematic is no modification to the Original work, and approved by DL2MAN/PE1NNZ		
Redrawn with notes: KD4SGE & WA4ITD (revision denoted in ( ) after Rev 1.0 below)		
Original Schematic: Rev 1.0 Date: 2021-11-27		
<b>DL2MAN &amp; PE1NNZ</b>		
Sheet: /(tr)uSDX_Main Board Parts Layout A v1.0/		
File: (tr)uSDX_Main Board Parts Layout A_v1-0.kicad_sch		
<b>Title: Main Board Parts Layout A</b>		
Size: A3	Date: 2022-07-10	Rev: 1.0(m)
KiCad E.D.A. kicad (6.0.5)		Id: 3/8

# Top (Front)

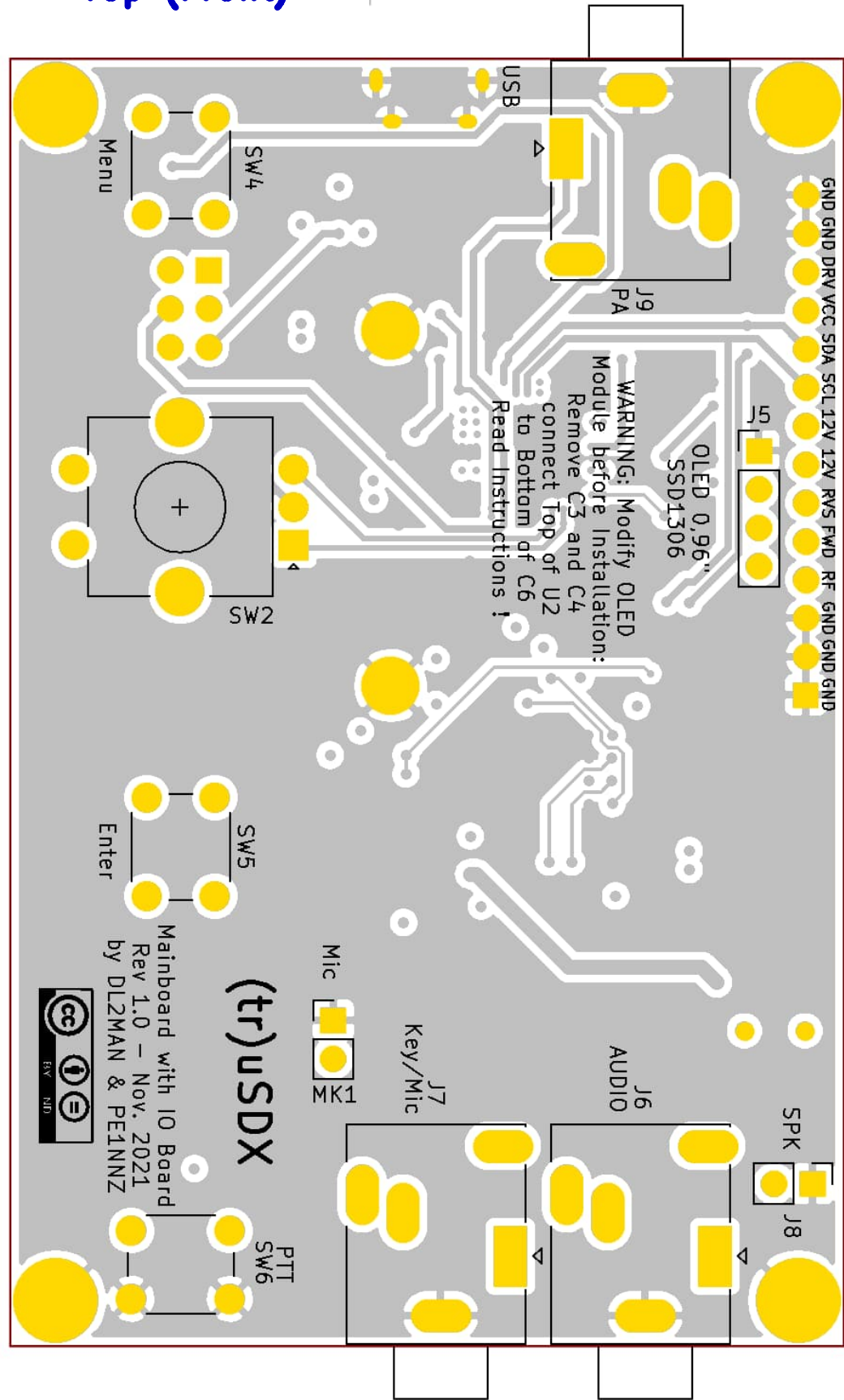

# Bottom (Back)

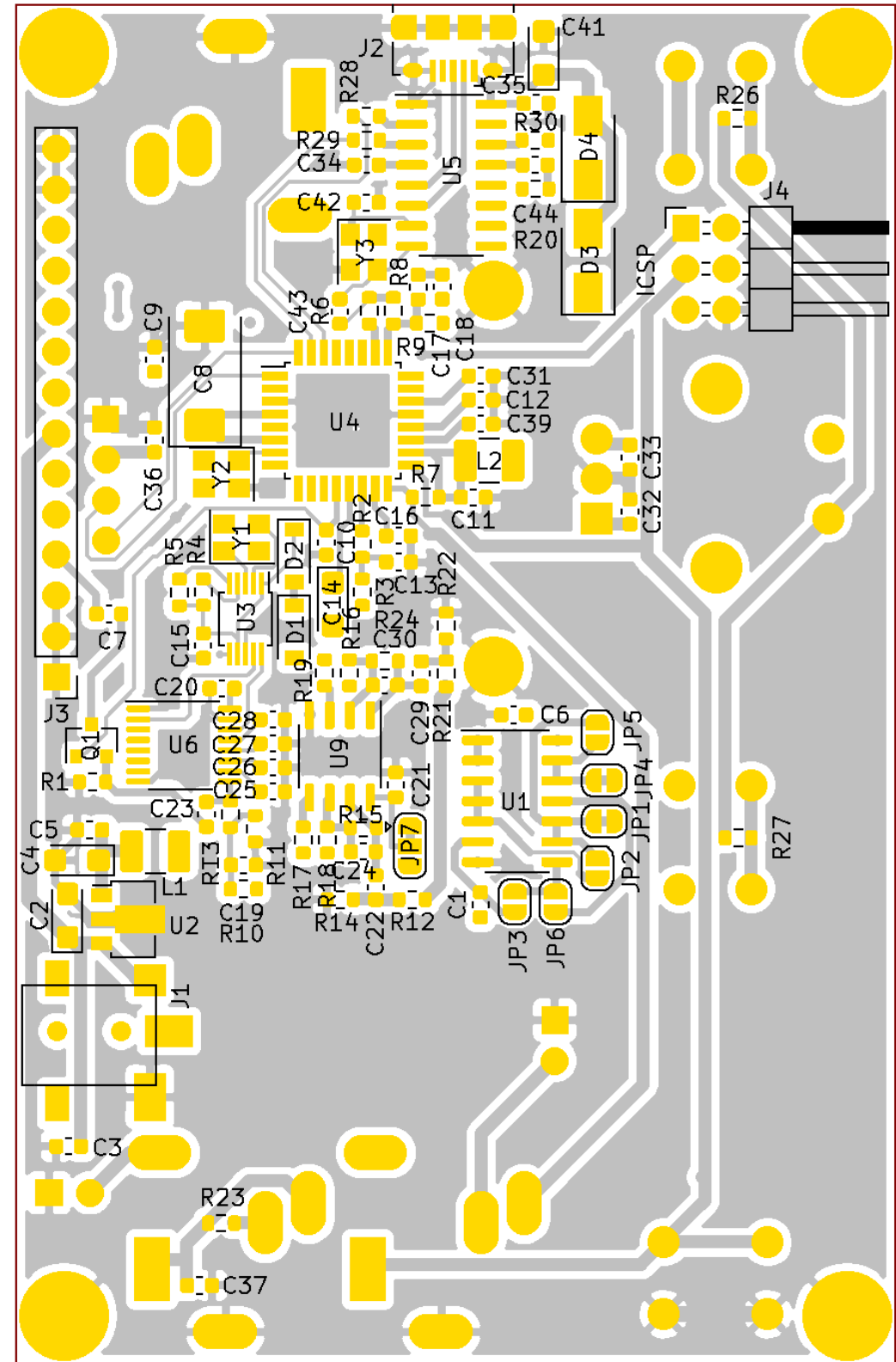

## Main Board Parts Layout with copper trace pattern

Note: This is a four layer board. The two internal layers are mainly power and ground planes. But there may also be a few internal traces which would not be visible. So, if a trace looks like it goes nowhere, it may continue on an internal layer.

This Schematic is no modification to the Original work, and approved by DL2MAN/PE1NNZ		
Redrawn with notes: KD4SGE & WA4ITD (revision denoted in ( ) after Rev 1.0 below)		
Original Schematic: Rev 1.0 Date: 2021-11-27		
<b>DL2MAN &amp; PE1NNZ</b>		
Sheet: /(tr)uSDX Parts Main Board Parts Layout B v1.0/		
File: (tr)uSDX_Main_Board_Parts_Layout_B_v1-0.kicad_sch		
<b>Title: Main Board Parts Layout B</b>		
Size: A3	Date: 2022-07-10	<b>Rev: 1.0(m)</b>
KiCad E.D.A. kicad (6.0.5)		Id: 4/8

to Main Board

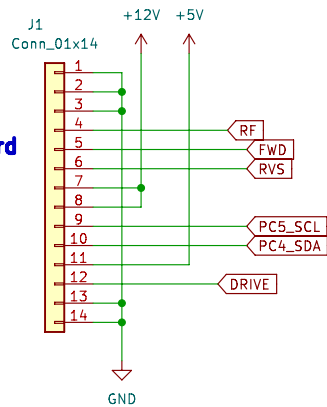

Suggested Mod for J1:  
Rather than female; the connector should be male since there is not power on these pins when the RF board is not attached to the main board.

### Latching Relay Control (Band Select)

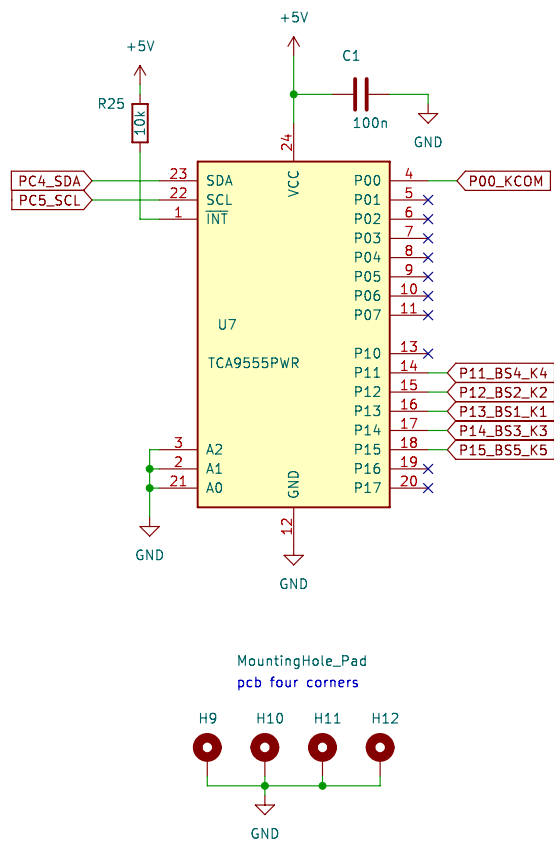

MountingHole\_Pad  
pcb four corners

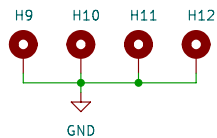

### Latching Relay Notice:

The relays are latching types, the coil is only energized to toggle the relay. Which way the relay toggles depends on the direction of the current thru the coil.

Mechanical force maintains the 'toggle'. However, strong vibrations or sudden impact(s) can cause a relay to 'toggle' changing the LPF configuration and, therefore, performance. This change is NOT detected by the software and will not be shown on the display. If such a condition is suspected it can be corrected by changing to another band and back, or by powering off/on the radio.

### Band Slots – LPF Filters for 'Lo' bands (20/30/40/60/80m)

Values given are when using three BS170s (Q1, Q2 and Q3)  
If using Q4 or Q5 or a different MOSFET then values may be different.

\*Capacitors not placed/installed are shown with a value of 'np'.  
\*Toroids wound using 0.4mm(18mil)[26ga] wire.

See sheet 6 and <https://dl2man.de> for more information.

Inductors/transformers use two different material types.  
Iron is shown with solid lines and ferrite has dashed lines, as shown: Powder Iron Ferrite

#### Band Slot 1

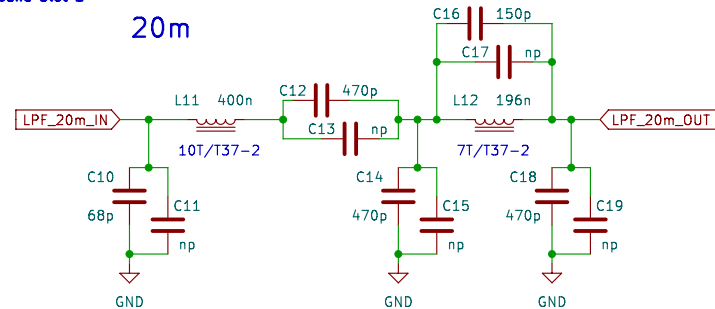

#### Band Slot 2

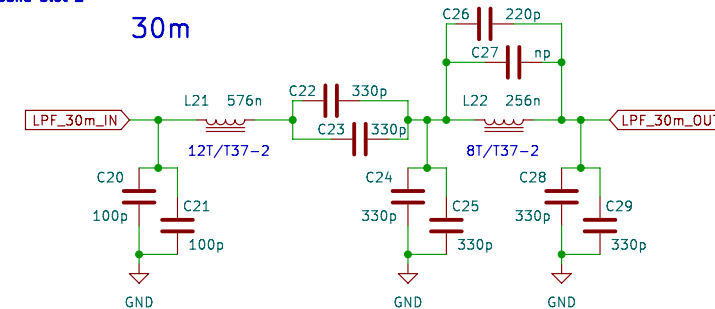

#### Band Slot 3

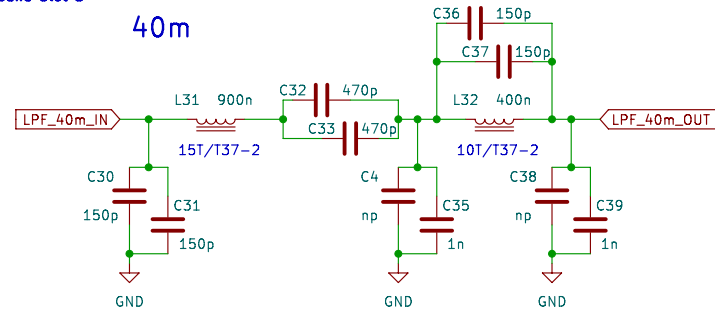

#### Band Slot 4

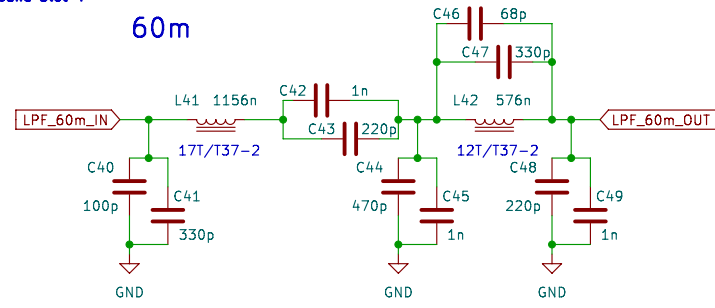

#### Band Slot 5

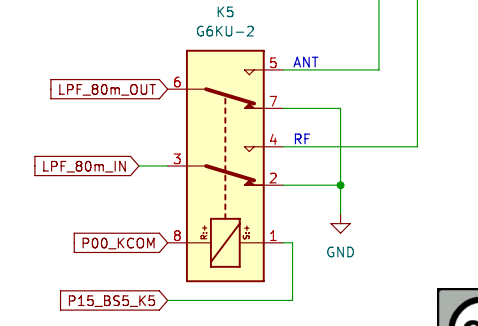
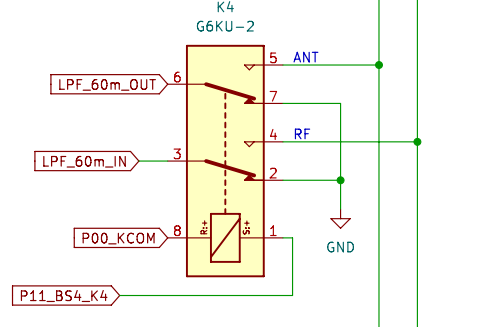
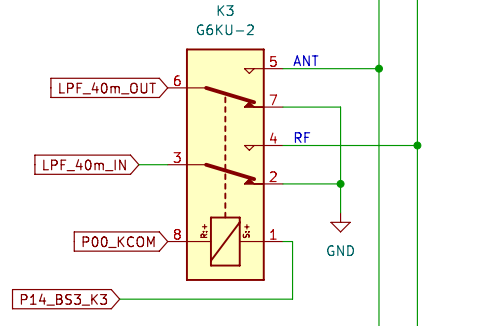
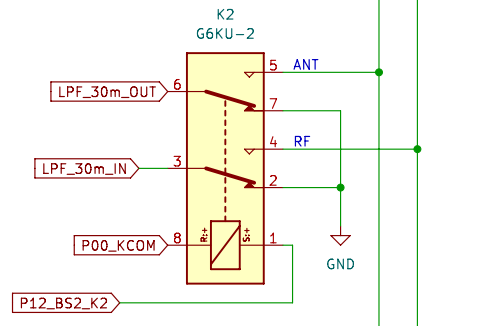
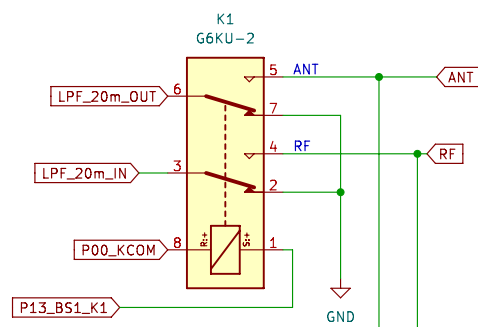
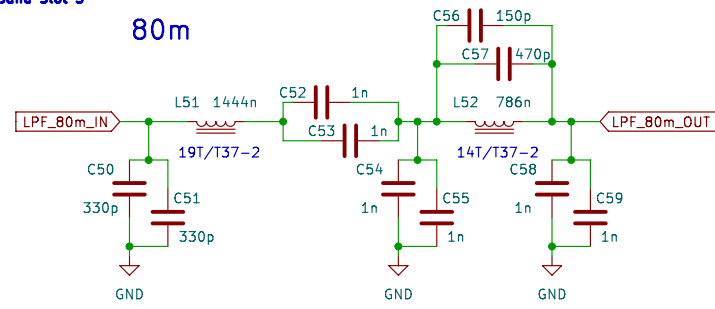

### Power/SWR Bridge

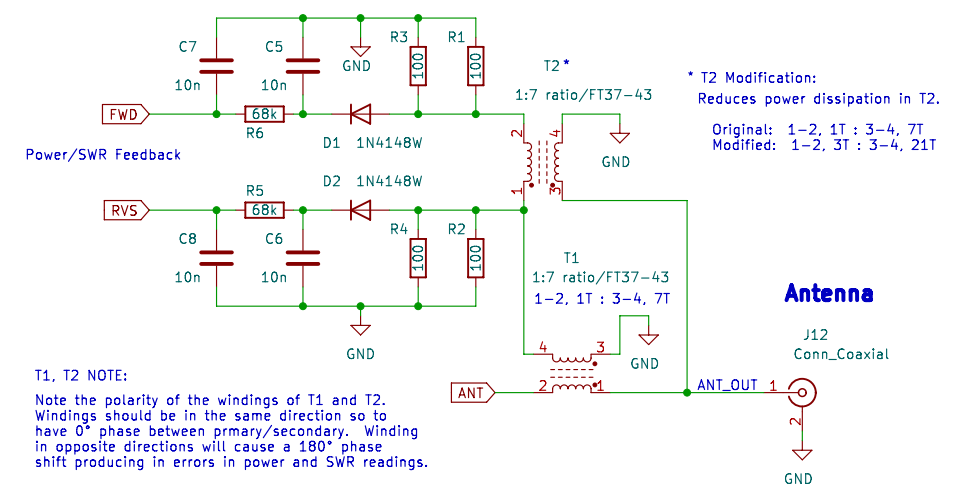

T1, T2 NOTE:  
Note the polarity of the windings of T1 and T2. Windings should be in the same direction so to have 0° phase between primary/secondary. Winding in opposite directions will cause a 180° phase shift producing in errors in power and SWR readings.

### Voltage/Current Measurement (Efficiency Measurement)

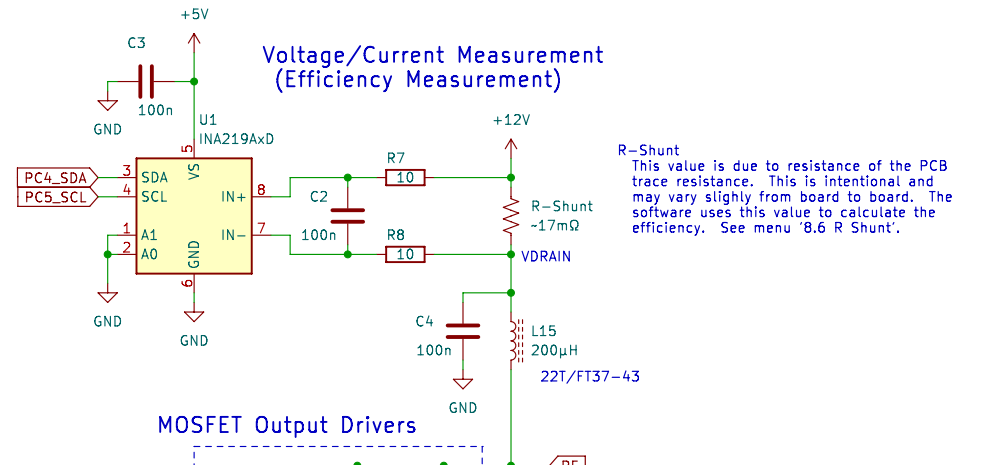

R-Shunt  
This value is due to resistance of the PCB trace resistance. This is intentional and may vary slightly from board to board. The software uses this value to calculate the efficiency. See menu '8.6 R Shunt'.

### MOSFET Output Drivers

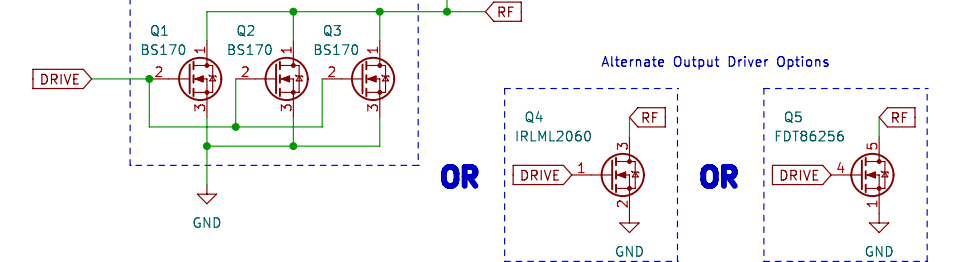

### More Information:

Videos of the build, tuning and other (tr)uSDX information can be found at:  
\* DL2MAN's website: <https://dl2man.de/>  
\* The (TR)uSDX forum: <https://forum.dl2man.de/>  
\* YouTube DL2MAN channel: <https://www.youtube.com/channel/UCqbnQWUjwH4K3FJtXbmrIA>

### A few reasons for redrawing the schematic:

- Mainly to improve clarity and aid in troubleshooting by:
  - \* Combining parts into functional groups reducing the number of global labels used. A few label names were also modified for clarity of function. One or two were added as a result of grouping parts. This also makes it easier to better understand the design and functional blocks of the (tr)uSDX.
  - \* Power and grounds were changed from 'global labels' to 'power' labels. This helps separate power distribution from signal distribution; making it easier to follow the signal paths.
  - \* The ATmega328P symbol was modified to show the three hidden power pins. This can be relevant as the ATmega328PB (note the 'PB'), version changes two of the pins to signal pins.
  - \* Doing a design, schematic and pcb is a lot of work. It is even more work to go back to revise and clean up things. Thanks to DL2MAN & PE1NNZ done to bring this project to reality. So, we thought this would assist and contribute to the (tr)uSDX project and the Amateur Radio community.

This Schematic is no modification to the Original work, and approved by DL2MAN/PE1NNZ  
Serial resonance Class E with SWR measurement  
Redrawn with notes: KD4SGE & WA4ITD (revision denoted in ( ) after Rev 1.0 below)  
Original Schematic: Rev 1.0 Date: 2021-11-27

### DL2MAN & PE1NNZ

Sheet: [/tr\)uSDX RF Board v1.0/](https://github.com/dl2man/truSDX_RF_Board_v1.0)  
File: [tr\)uSDX\\_RF\\_Board\\_v1-0.kicad\\_sch](https://github.com/dl2man/truSDX_RF_Board_v1.0.kicad_sch)

### Title: (tr)uSDX RF Board

Size: A3 Date: 2022-07-10  
KiCad E.D.A. kicad (6.0.5)

Rev: 1.0(m)  
Id: 5/8



## Band Slots – LPF Filters for 'Classic' band (10/15/20/40/80m)

Tested by DL2MAN (20 May 2022)  
Using Q5, FDT86256 with a PA Bias of 160

More info: <https://dl2man.de/2-trusdx-assembly/>

### Band Slot 1

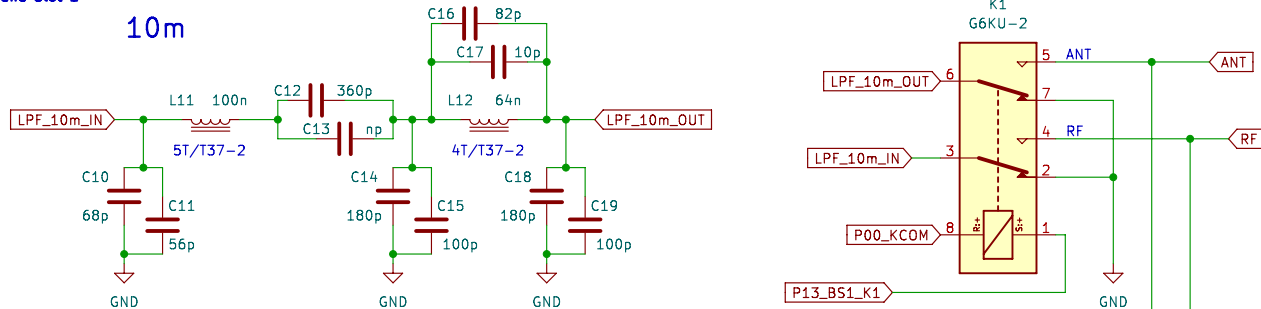

### Band Slot 2

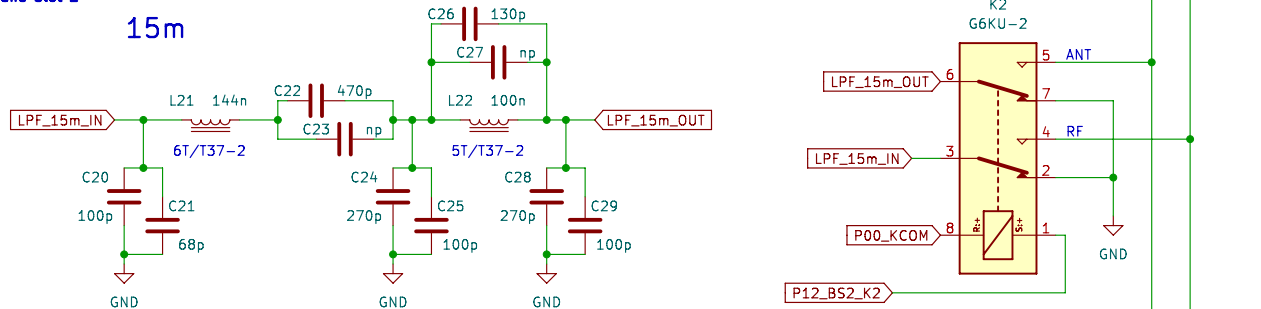

### Band Slot 3

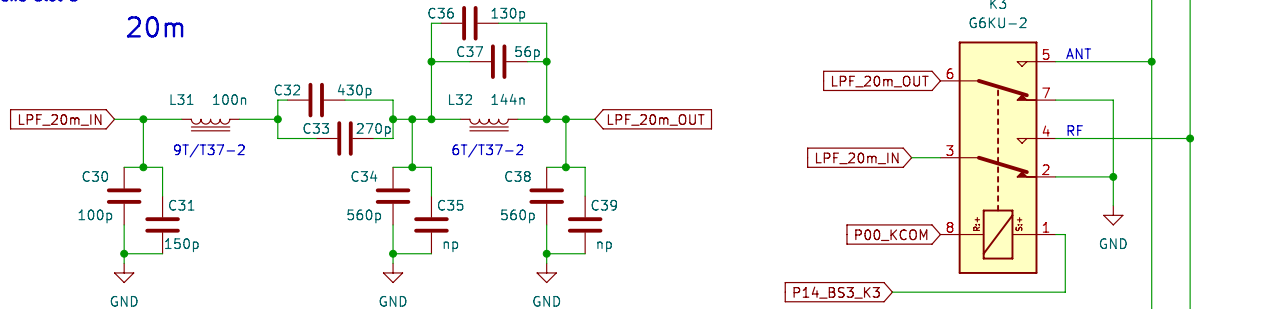

### Band Slot 4

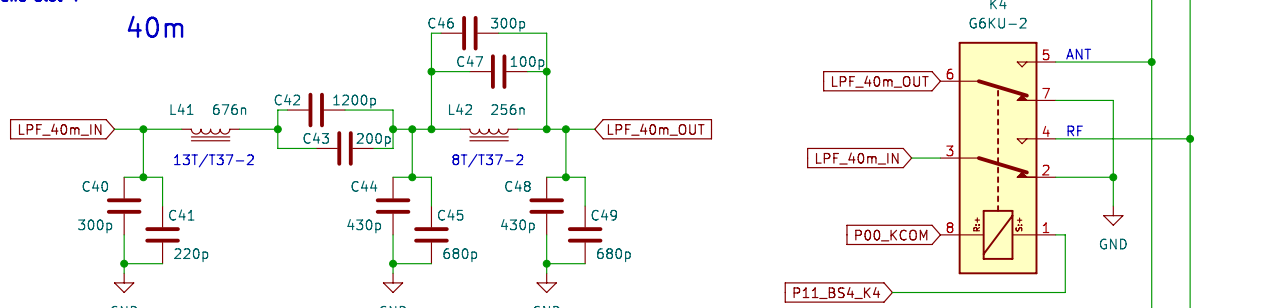

### Band Slot 5

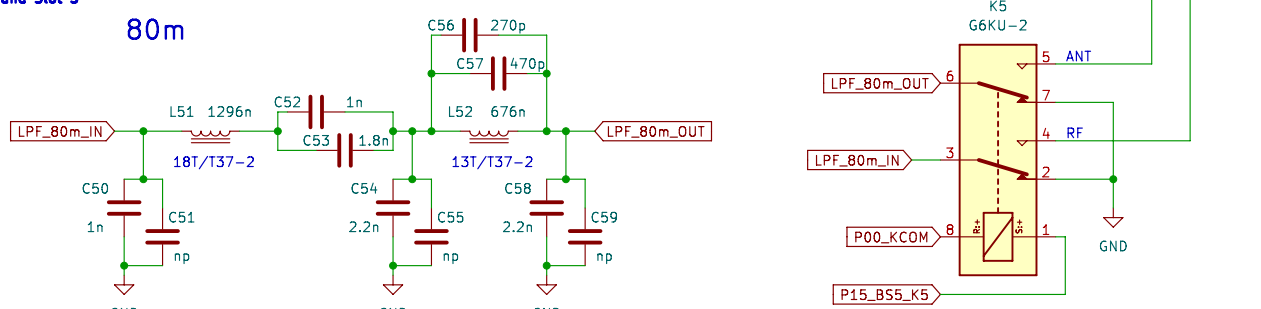

## Generic Band LPF Design

LPF – Low Pass Filter

The LPF component reference number has the following pattern:

Simply, each component is referenced by a letter and two numbers. The first number is the band slot, 'n' and the second number, 'y' is the specific component.

For example, capacitors would be 'Cny'. There are ten capacitors in each LPF. So, in Band Slot 1 the reference for each capacitor would be C10, C11, C12,...C19, in Band Slot 2 it would be C20, C21, C22,..., C29. And so on for Band Slots 3 to 5.

Inductors, Lny, follow the same scheme.

Relays are an exception as there is only one relay per LPF. So a relay, K, is simply 'Kn'.

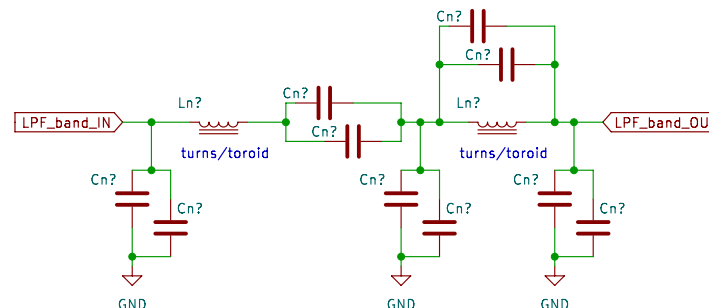

**Remember:** (tr)uSDX Filter Capacitors ALWAYS need to be COG/NPO Types, rated for at least 100V !

## Simplified Filter Design

Technically, it is not a low pass filter. Rather a combination of a shunt capacitance, bandpass and PI network. The shunt capacitance (which includes the Coss of the MOSFET(s)), sets the load, which in turn set the power of the Class E output. The bandpass is also part of the inductive load required for the Class E output. However, the low frequency cutoff of the bandpass is sufficiently low as to be considered ignored. While the PI network is for impedance transformation and second harmonic notch filtering.

Recommending readings:

Class E Power Amplifiers for QRP by David Cripe NMS, May 14, 2009  
<http://amfone.net/Amforum/index.php?action=dlattach;topic=35824.0;attach=41753>

A calculator for this design can be found on WA0ITP website:  
<http://www.wa0itp.com/class%20e%20design.html>

Also of note is, in the (tr)uSDX, the transmitted signal goes from 'in-to-out' while the received signal is reversed, going from 'out-to-in'.

The 2nd harmonic notch is adjusted by changing the winding spacing on L2. Windings closer together increases inductance and spreading apart decreases inductance. The efficiency is adjusted by changing the winding spacing on L1. Note that higher power does not mean higher efficiency.

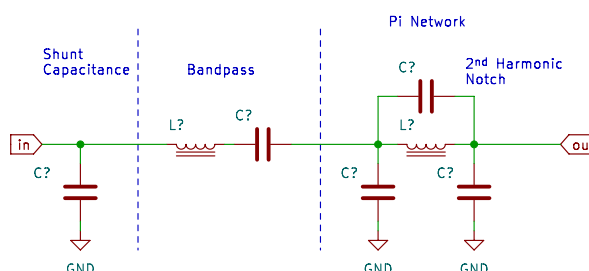

## Band Configurations

The (tr)uSDX provides for three bands configurations: Lo, Hi and Classic. Each configuration expects a specific band filter to be in a given band slot. So for the 'Lo' bands; the 20m band, in band slot 1, the 30m in band slot 2, and so on.

Each configuration also transitions from one band slot to the next at specific frequencies (relay f transition). So, for the 'Lo' configuration, when tuning, going from 12.99999 MHz to 13.00000 MHz, the relays will toggle from band slot 1 to slot 2; from 30m to 40m the relays toggle at 9 MHz; and so forth.

Failing to place filters in the appropriate band slot AND select the correct band configuration can result in unexpected results and transmission on unintended frequencies.

Band Configuration	Band Slot	1	2	3	4	5
Lo (current Standard)	Relay f Transition	20m	30m	40m	60m	80m
Hi (Only Hi Bands)	Relay f Transition	10m	12m	15m	17m	20m
Classic (Classical Bands w/o WARC)	Relay f Transition	10m	15m	20m	40m	80m

f – frequency

There are several online and offline tools to calculate the turns/toroids for a band. Search for one you like best. Below are examples of two offline calculators that can be used.

One tool is:  
mini Ringkern-Rechner – <https://www.dl0hst.de/mini-ringkern-rechner.htm#en>

Another is:  
Coil64 (Coil32) – <https://coil32.net/>

Disclaimer: Downloading and installing any programs from the Internet come with risks and is the responsibility of the end user. The authors of this document are not responsible for any errors or damages in their use. Download responsibly.

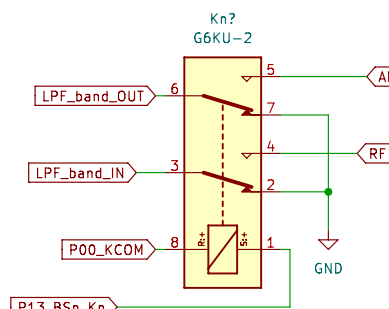

## LPF Design Considerations:

The values of the capacitors and inductors can vary for several reasons. Some of those reasons include:

- \* Tolerance of component values; which can usually vary by 5% or more. This not only includes capacitors but also the toroids.
- \* The PCB traces add stray capacitance and inductance.
- \* The Coss of MOSFETs can vary; either by switching types (BS170 to FDT86256) and/or by count, using multiple BS170s.
- \* Whether T2 has been modified for 1:7 turns to 3:21 turns.
- \* And many other random things including metal placed in close proximity to the RF board. This also includes strong magnetic fields.
- \* Keep in mind the frequencies the relays transition from one band to the next when tuning.

As a result, for a given band, the capacitance and inductor values may vary slightly from board to board and as MOSFETs are changed. So when using values given by other users, the MOSFET and number of, should be specified. But, even then the values would simply be a starting point and tweaking may still be required.

## Capacitor/Toroid Notes:

In the LPF circuits, use only:  
\* NPO/COG Capacitors rated for at least 100V  
\* Toroids from Micrometals or Amidon

The wire specified for winding the toroids; 0.4mm(18mil)[26ga]. Smaller diameter wire will decrease the Q of the inductor and a larger wire will increase it.

Keep in mind that several things will affect the inductance of the inductors:  
\* How loose or snugly the turns are wrapped on the toroid. A loose turn has lower inductance than a snug turn. But too snug a turn can be hard to adjust the spacing later when adjusting the 2nd harmonic filter.  
\* The spacing between turns. As turns, even a few turns, get closer together, the inductance will increase. The lowest inductance is obtained with evenly spaced turns around the toroid.

So, when winding the coils:  
\* A wire pass thru the center of the toroid counts as a turn.  
\* Try to evenly space the turns around the toroid.  
\* Avoid overlapping windings.

After the build, the LPF tuning is done by adjusting the toroid winding spacing to notch out the second harmonic frequency, using equipment such as a nanoVNA.

## More Information:

Videos of the build, tuning and other (tr)uSDX information can be found at:  
\* DL2MAN's website: <https://dl2man.de/>  
\* The (TR)uSDX forum: <https://forum.dl2man.de/>  
\* YouTube DL2MAN channel: <https://www.youtube.com/channel/UCqbnQWUjwH4K3FJtxbmrIA>

This Schematic is no modification to the Original work, and approved by DL2MAN/PE1NNZ  
Serial resonance Class E with SWR measurement  
Redrawn with notes: KD4SGE & WA4ITD (revision denoted in ( ) after Rev 1.0 below)  
Original Schematic: Rev 1.0 Date: 2021-11-27

**DL2MAN & PE1NNZ**  
Sheet: (tr)uSDX RF Board – Alternate Bands v1.0/  
File: (tr)uSDX\_RF\_Board-Alt\_Bands\_v1-0.kicad\_sch

**Title: (tr)uSDX RF Board – Alternate Bands and Notes**  
Size: A3 Date: 2022-07-10 Rev: 1.0(m)  
KiCad E.D.A. kicad (6.0.5) Id: 6/8



# Top (Front)

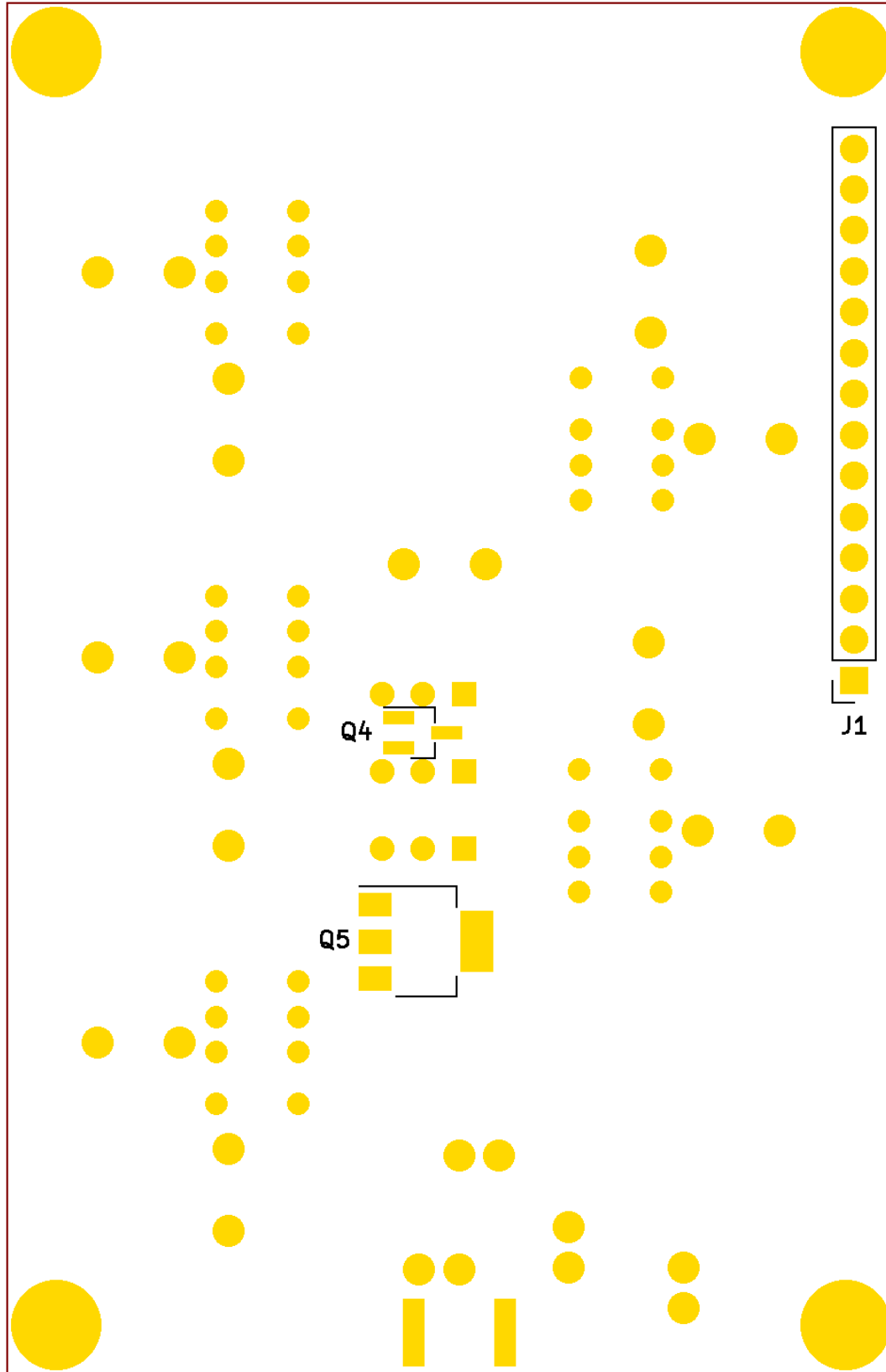

# Bottom (Back)

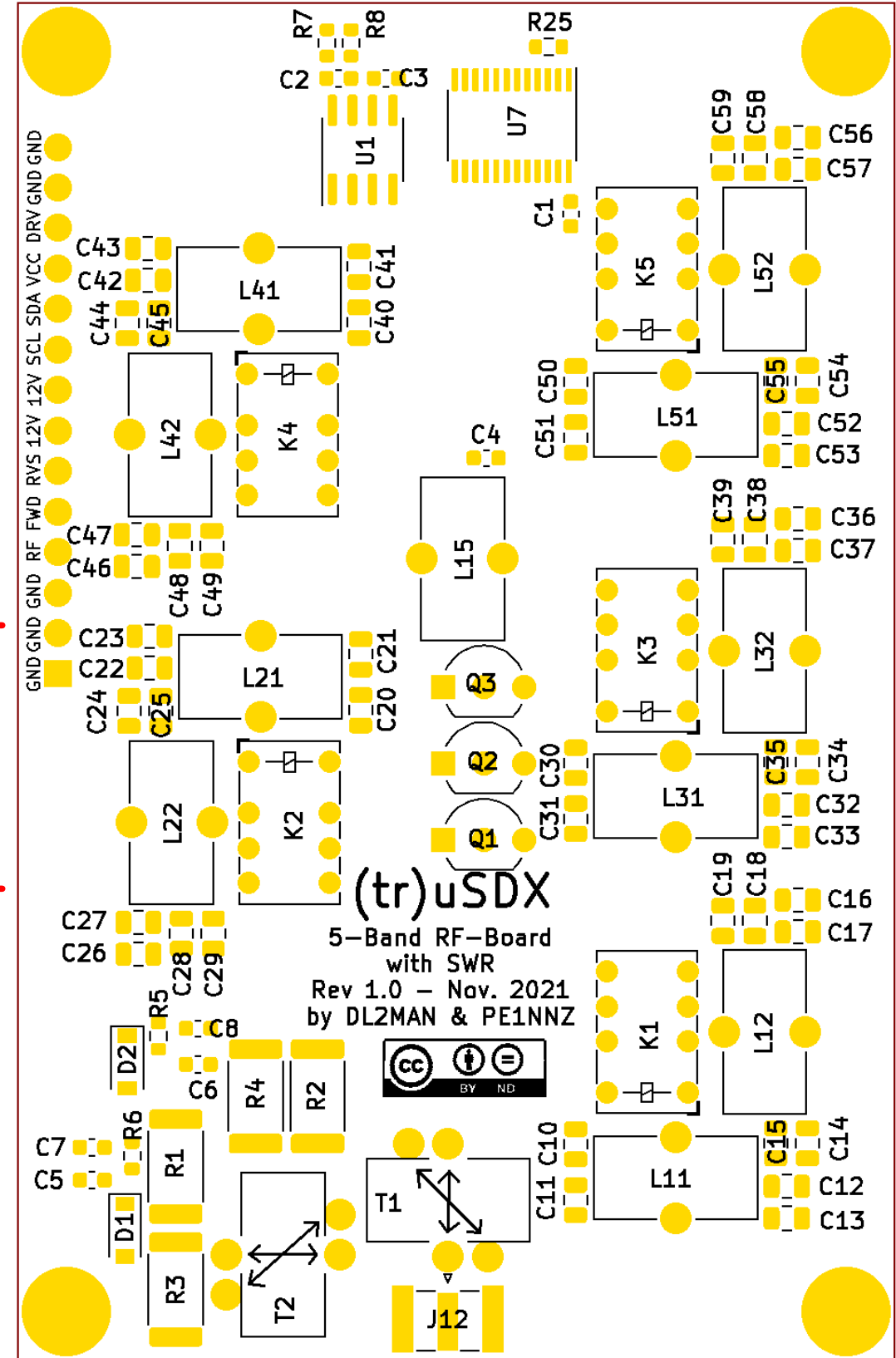

Band Slot 4  
 Lo - 60m  
 Hi - 17m  
 Cl - 40m

Band Slot 2  
 Lo - 30m  
 Hi - 12m  
 Cl - 15m

Cl = Classic

Band Slot 5  
 Lo - 80m  
 Hi - 20m  
 Cl - 80m

Band Slot 3  
 Lo - 40m  
 Hi - 15m  
 Cl - 20m

Band Slot 1  
 Lo - 20m  
 Hi - 10m  
 Cl - 10m

## RF Board Parts Layout without copper trace patterns

This Schematic is no modification to the Original work, and approved by DL2MAN/PE1NNZ

Redrawn with notes: KD4SGE & WA4ITD (revision denoted in ( ) after Rev 1.0 below)  
 Original Schematic: Rev 1.0 Date: 2021-11-27  
**DL2MAN & PE1NNZ**

Sheet: /RF Board Parts Layout A v1.0 /  
 File: (tr)uSDX\_RF\_Board\_Parts\_Layout\_A\_v1-0.kicad\_sch

**Title: RF Board Parts Layout**

Size: A3	Date: 2022-07-10	Rev: 1.0(m)
KiCad E.D.A. kicad (6.0.5)		Id: 7/8

# Top (Front)

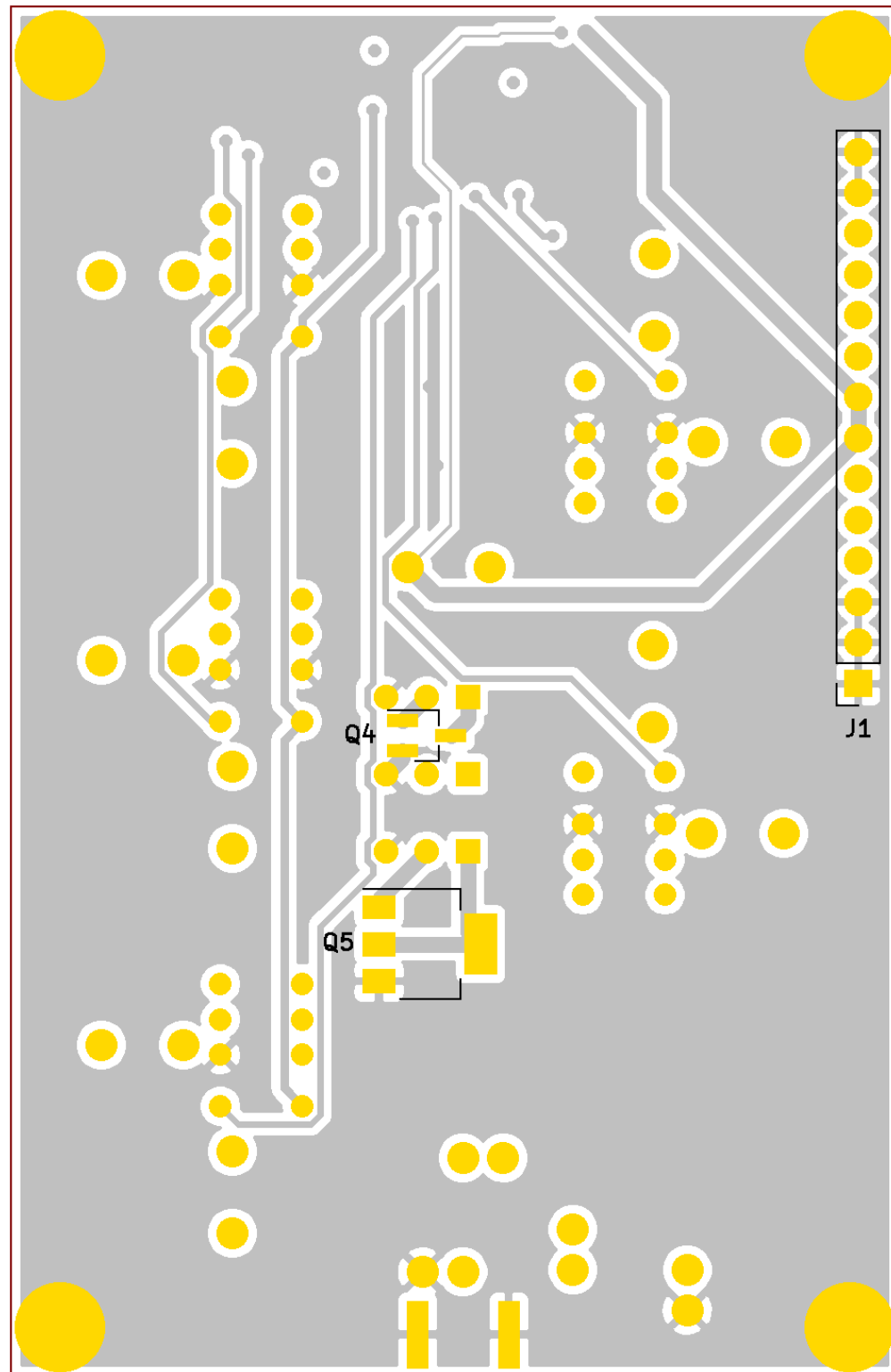

# Bottom (Back)

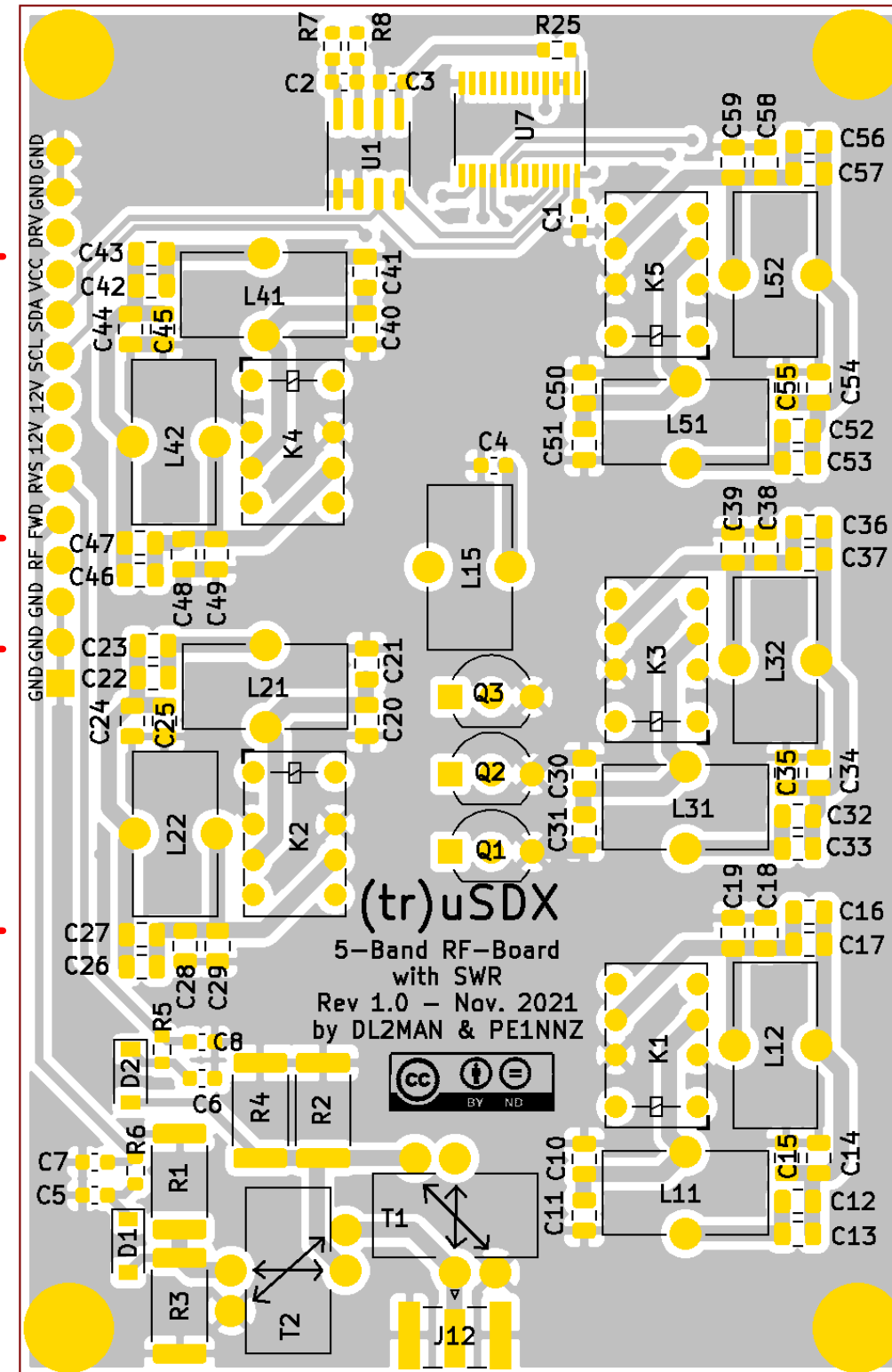

Band Slot 4  
**Lo - 60m**  
 Hi - 17m  
 Cl - 40m

Band Slot 2  
**Lo - 30m**  
 Hi - 12m  
 Cl - 15m

Cl = Classic

Band Slot 5  
**Lo - 80m**  
 Hi - 20m  
 Cl - 80m

Band Slot 3  
**Lo - 40m**  
 Hi - 15m  
 Cl - 20m

Band Slot 1  
**Lo - 20m**  
 Hi - 10m  
 Cl - 10m

## RF Board Parts Layout with copper trace patterns

Note: This is a four layer board. The two internal layers are mainly power and ground planes. But there may also be a few internal traces which would not be visible. So, if a trace looks like it goes nowhere, it may continue on an internal layer.

This Schematic is no modification to the Original work, and approved by DL2MAN/PE1NNZ		
Redrawn with notes: KD4SGE & WA4ITD (revision denoted in ( ) after Rev 1.0 below)		
Original Schematic: Rev 1.0 Date: 2021-11-27		
<b>DL2MAN &amp; PE1NNZ</b>		
Sheet: /RF Board Parts Layout B v1.0/		
File: (tr)uSDX_RF_Board_Parts_Layout_B_v1-0.kicad_sch		
<b>Title:</b>		
Size: A3	Date: 2022-07-10	<b>Rev: 1.0(m)</b>
KiCad E.D.A. kicad (6.0.5)		Id: 8/8