

# ELECRAFT KH1

## HAND-HELD, 5-BAND CW TRANSCEIVER

### OWNER'S MANUAL

Rev. A Oct. 6, 2023



# TABLE OF CONTENTS

<b>INTRODUCTION</b> .....	<b>4</b>
<b>GENERAL PRECAUTIONS</b> .....	<b>5</b>
<b>POWER SOURCE</b> .....	<b>5</b>
EXTERNAL SUPPLY .....	5
CHARGE STATUS LED .....	5
INTERNAL BATTERY .....	6
PRESERVING CLOCK TIME DURING CHARGING .....	7
<b>UTILITY MOUNTING POINTS</b> .....	<b>7</b>
<b>LOG TRAY AND PEN</b> .....	<b>8</b>
<b>ANTENNAS</b> .....	<b>9</b>
BUILT-IN ATU AND WHIP MATCHING NETWORK .....	9
TIPS FOR USING COMPACT ANTENNAS .....	10
GROUND CONNECTION AND COUNTERPOISE WIRE .....	11
SPARE GROUND NUT .....	11
<b>CARRYING CASE</b> .....	<b>12</b>
<b>KEY/DATA JACK</b> .....	<b>12</b>
DATA CONNECTION .....	13
<b>HEADPHONES AND SPEAKERS</b> .....	<b>13</b>
<b>DISPLAY</b> .....	<b>13</b>
<b>KH1 FRONT PANEL REFERENCE</b> .....	<b>14</b>
<b>BASIC OPERATION</b> .....	<b>15</b>
TURNING THE KH1 ON/OFF .....	15
SWITCH TAP AND HOLD FUNCTIONS .....	15
VFO KNOB FUNCTIONS .....	15
AF/MON KNOB FUNCTIONS .....	15
DISPLAY MAPPING TO SWITCHES 1-4 .....	16
RECEIVER CONTROLS .....	16
PF <sub>n</sub> AND TRANSMITTER CONTROLS .....	16
BAND AND MODE CONTROLS .....	16
KEYER SPEED CONTROLS .....	17
ATU TUNING .....	17
MESSAGE PLAY / RECORD CONTROLS .....	17
USING THE MENU .....	17
<b>ADVANCED FEATURES</b> .....	<b>18</b>
SCAN/MINI-PAN .....	18
USER-PROGRAMMABLE FUNCTIONS .....	19
REAL-TIME CLOCK .....	19
CUSTOMIZING POWER LEVELS .....	19
TEXT DECODE AND DISPLAY .....	20
CW/SSB CROSS-MODE OPERATION .....	20
GENERAL COVERAGE RECEIVE .....	20
MANUALLY TUNING THE ATU .....	21
AMPERE-HOUR METERING .....	21
BUILT-IN LOGGING .....	21
INITIALIZING PARAMETERS (EINIT) .....	21

<b>UPDATING FIRMWARE .....</b>	<b>22</b>
FORCED DOWNLOAD .....	22
<b>REMOTE CONTROL .....</b>	<b>22</b>
COMPUTER INTERFACE .....	22
<b>CONFIGURATION .....</b>	<b>23</b>
<b>ALIGNMENT .....</b>	<b>23</b>
RECEIVER .....	23
TRANSMITTER .....	23
<b>MENU FUNCTIONS .....</b>	<b>24</b>
<b>TROUBLESHOOTING .....</b>	<b>32</b>
GENERAL .....	32
TRANSMIT .....	32
RECEIVE .....	33
<b>ERROR MESSAGES .....</b>	<b>33</b>
<b>THEORY OF OPERATION .....</b>	<b>35</b>
<b>SPECIFICATIONS .....</b>	<b>36</b>
GENERAL .....	36
RECEIVER .....	36
TRANSMITTER .....	36
<b>CUSTOMER SERVICE AND SUPPORT .....</b>	<b>37</b>
REPAIR / ALIGNMENT SERVICE .....	37

# INTRODUCTION

The Elecraft KH1 is a pocket-sized, 40/30/20/17/15 meter, low-power CW transceiver optimized for hand-held as well as table-top operation. The transceiver itself weighs only 6 oz. (0.17 kg); with battery and all options installed, total weight is 13 oz. (0.36 kg). This allows it to be operated HT-style indefinitely without causing arm or wrist fatigue. It's also an ideal backup rig, requiring little packing space.

The KH1's unique form-factor provides multiple advantages for field operation:

**USER INTERFACE** Both the knobs and optional keyer paddle (KHPD1) are at the lower end of the transceiver. This is ideal when you're sitting or standing, holding the radio with one hand while operating it with the other. The four pushbutton switches are close by, aligned with LCD text fields.

**FIELD LOGGING** The KHLOG1 fold-out log tray solves one of the most vexing problems with SOTA, HF Pack, and general field operation: how to conveniently log contacts, in any situation. The tray can be installed on either side of the radio, facilitating left- or right-handed use. Log sheets can be swapped in with one hand. The tray also folds to protect the front panel when closed.

**BUILT-IN WHIP** The KHATU1 antenna tuner comes with a modified top panel that embodies a whip mounting screw, loading coil, and band-selection switch for use on 20/17/15 meters (plus 30 m at reduced power). The supplied telescoping whip clips to the side of the rig when not in use. The ATU matches a wide range of loads, and works with the BNC jack as well as the whip.

The KH1 covers the full frequency range of each ham band, with power output of over 5 watts. Many hours of field operation are ensured by an internal 2.6 AH, 11 V Li-ion battery (KXBT2). An internal charger (KHIBC1) keeps the battery topped off, ready to go when you are.

The KH1 has many other features, including:

- small speaker
- real-time clock (RTC)
- SWL band: 6.7 - 22.0 MHz (uses SSB mode to copy AM); ATU can be manually tuned to peak signals
- CW text decode/display, plus 32K EEPROM for transmit text capture and logging
- VFO locking, RIT, and XIT
- SSB/CW cross-mode operation
- Easy-to-use scan/mini-pan function for signal hunting
- upgradeable firmware via supplied USB cable and *KH1 Utility* application
- full remote control for specialized applications
- light gray case that stays cool, even in bright sunlight
- custom, zippered carrying case with utility pockets (pg. 12)

We hope the KH1 becomes your go-to rig for ultralight adventure travel – whether to exotic locales, to the urban/wilderness boundary, or just to your own back yard.

Wayne, N6KR  
Eric, WA6HHQ

# GENERAL PRECAUTIONS

- **Do not touch the telescoping whip when transmitting, as you could receive an RF burn. Set the whip's band switch to the center-off position when using the BNC jack.** (A telescoping whip and internal matching components are supplied with KHATU1 option.)
- **Avoid prolonged exposure to moisture.** The KH1 can be used in light precipitation, but it is not waterproof. If the log tray is installed, it can be folded over the front panel for additional moisture resistance.

## POWER SOURCE

### EXTERNAL SUPPLY

An 8-15 V low-noise power supply, solar panel, or battery can be connected to the external supply jack on the left side. The center pin is (+), as is the **white-striped wire** on the supplied power cable. The plug can be a Switchcraft model S760 or similar (2.1 mm pin aperture, 5.5 mm barrel diameter).

**i** **Power output varies with supply voltage.** On all bands, maximum power output when running from 11 V is typically 5 to 7 watts into a 50 ohm load. (See *MENU:ADJ PWR.*)

**i** The internal and external DC jacks are identical, and are diode-isolated from each other. The jack with the higher voltage will power the transceiver. For example, if you have an internal battery pack plugged in that measures 10.5 V, and an external supply also plugged in that measures 12 V, the external source will supply power. (To display supply voltage and current, see *MENU:DISP MODE*. A more accurate display of internal battery voltage, along with an amp-hours meter, is also available. See *MENU:VBAT.*)

### CHARGE STATUS LED

A small LED near the power switch provides power-on and charge status indications, as follows.

#### **With a standard KHDC1 DC input module installed (no charger module):**

- LED is **GREEN** when the KH1 is ON; **UNLIT** when it is OFF. (Regardless of which DC jack is in use.)

#### **With a KHIBC1 internal battery charger installed:**

- With no external supply connected: the LED is **GREEN** when the KH1 is ON; **UNLIT** when it is OFF.
- With an external operating/charging supply connected: the LED is **RED** when the radio is OFF and charging; **ORANGE** when the radio is ON and charging; **GREEN** when charge is complete and the radio is ON; **UNLIT** when charge is complete and the radio is OFF.

**⚠** See important cautions on next page regarding charging the battery internally or externally.

## INTERNAL BATTERY

The KH1 is designed to use an Elecraft KXBT2 lithium-ion battery pack. This pack is rated at 11 V, 2.6 Ah. Thanks to the KH1's low receive-mode current drain (~50 to 80 mA), the KXBT2 can provide full power output (5 to 7 watts) for 4 to 12 hours of typical QRP operation, and up to 50 hours receive-only.

The battery pack can be internally recharged at a C/10 rate (~250 mA) using a KHIBC1 internal charger. In this case, charging voltage (nominally ~14 V, minimum 12 V) is provided by the same supply that operates the radio. A KXBC2 external fast-charger can also be used (see cautions below.)

**⚠ CAUTION: IF A KHIBC1 INTERNAL BATTERY CHARGER IS INSTALLED, DO NOT USE ANY BATTERY PACK OTHER THAN THE KXBT2**, which has built-in protection circuitry. The use of an incompatible battery pack may be unsafe and may void the warranty.

**⚠ CAUTION: THE BATTERY PACK MUST BE REMOVED FOR RECHARGING WHEN USING A KXBC2 FAST CHARGER.** Fast chargers generate RFI, and are NOT suitable for internal charging or for radio operation.

Follow the steps below to install or remove the battery pack.

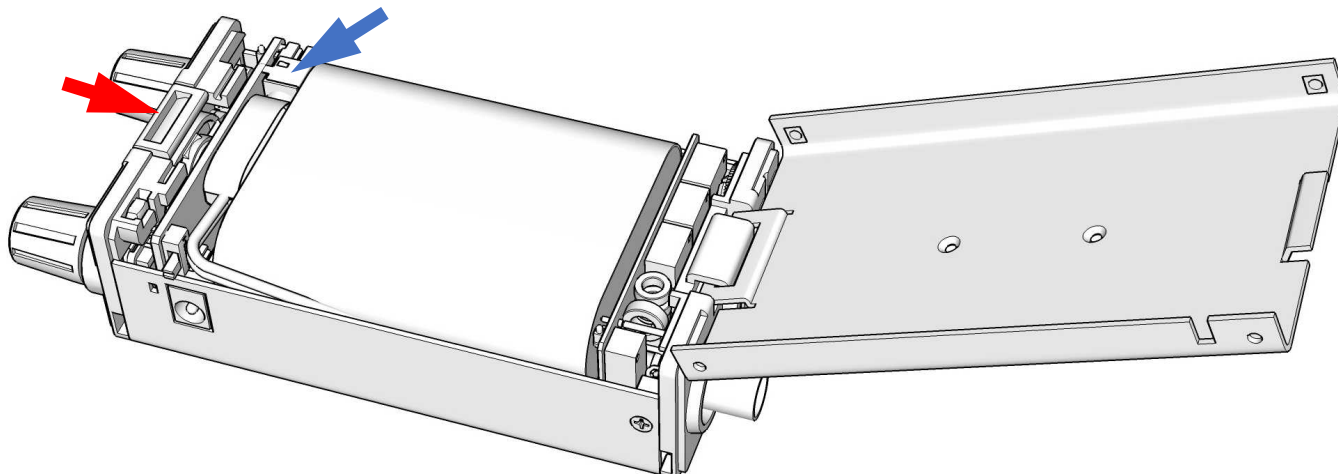

**⚠** The aluminum back cover has a tab that forms a hinge with the plastic top panel. Once the back cover has been rotated to a perpendicular position, slide its metal tab backward about 1/8" (3 mm) before continuing rotation. This will make it easier to close the back cover.

- Before installing or removing the battery, turn the KH1 OFF using the small slide switch near the external supply jack. The OFF setting is AWAY from the jack.
- Release the KH1's back panel using the sliding thumb latch near the knobs (**red arrow**). Then lift open the back cover, sliding it backward while rotating the metal tab through the hinge.
- Plug the battery pack into the internal DC jack. **Make sure the plug is inserted up to its shoulder.**
- Place the battery into position, then dress the excess wire to the side approximately as shown.
- Slide the thumb latch out of the way of the back panel's tab, then secure the panel.

**⚠** When unplugging the battery, always use the plastic pull tab. Also press lightly where shown by the **blue arrow** to ensure that the internal charger or DC input module does not come unplugged due to excessive plug extraction force.

- ❗ The back cover can be completely removed if desired via a thin slot at the back of the plastic hinge.
- ❗ The KH1 includes an amp-hour metering function that allows you to better estimate remaining battery life. See pg. 21.

## PRESERVING CLOCK TIME DURING CHARGING

The KH1 includes a real-time clock (RTC), useful for logging (see *MENU:LOGGING*). RTC circuitry is powered by the battery or power supply (internal or external).

**When no power supply or battery is connected, the RTC's time registers are preserved for about 1 minute** by a large-value capacitor. This allows sufficient time to swap batteries without losing the time setting.

## UTILITY MOUNTING POINTS

To enhance versatility, the KH1 provides several utility mounting holes that could be used for future Elecraft accessories or for user-supplied hardware. These are located in three places (see arrows below).

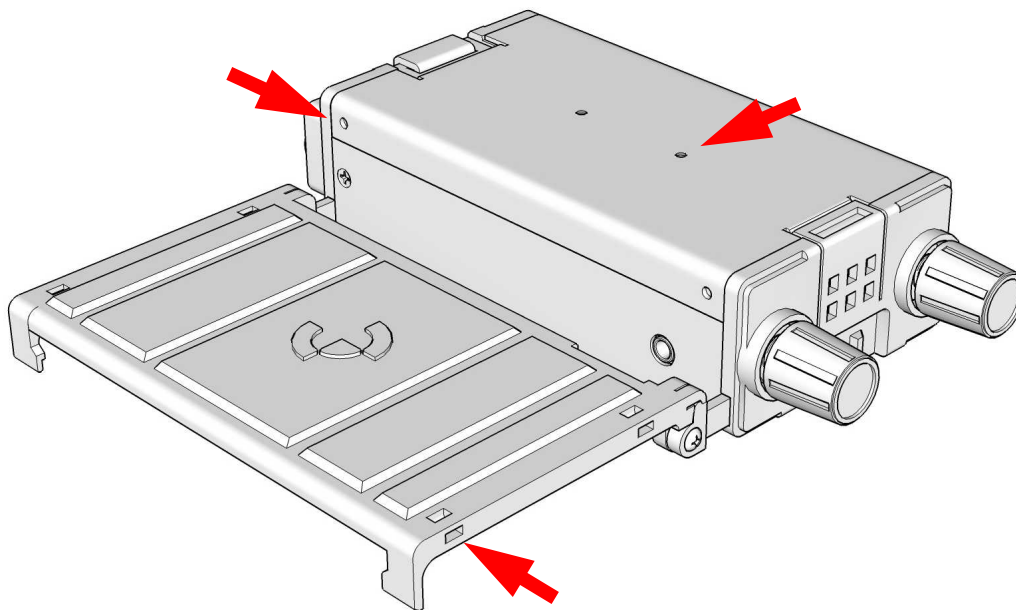

**BACK COVER, MIDDLE:** There are two **#2 flat head** screw holes in the middle of the back cover. The screw heads must go on the **inside**, and must be flat head to clear the Li-ion battery pack.

**BACK COVER, SIDES:** There are two #2 holes on each side of the back cover. These are intended for use with the whip mounting clips that are supplied with the KHATU1 option, though they could be used as attachment points for other hardware. **Pan head screws** must be used in these locations, with the heads on the **inside**. Any other hardware on the inside (such as a nut or washer) would interfere with circuitry.

**LOG TRAY:** The KHLOG1 log tray (discussed in the next section) has holes at each corner. Some operators may wish to use one of these as an anchor point for a pen lanyard, guarding against loss of the pen when dropped. (A lanyard should not be needed with the supplied mini ball-point pen, however, as it clips securely to the log tray.)

# LOG TRAY AND PEN

The KHLOG1 log tray option makes it easy to log contacts while standing, walking, sitting on a trail or rock, or in other situations where there's no convenient writing surface. Such situations occur often during field use. Sometimes sitting is impossible due to insects, mud, thorns, or other impediments.

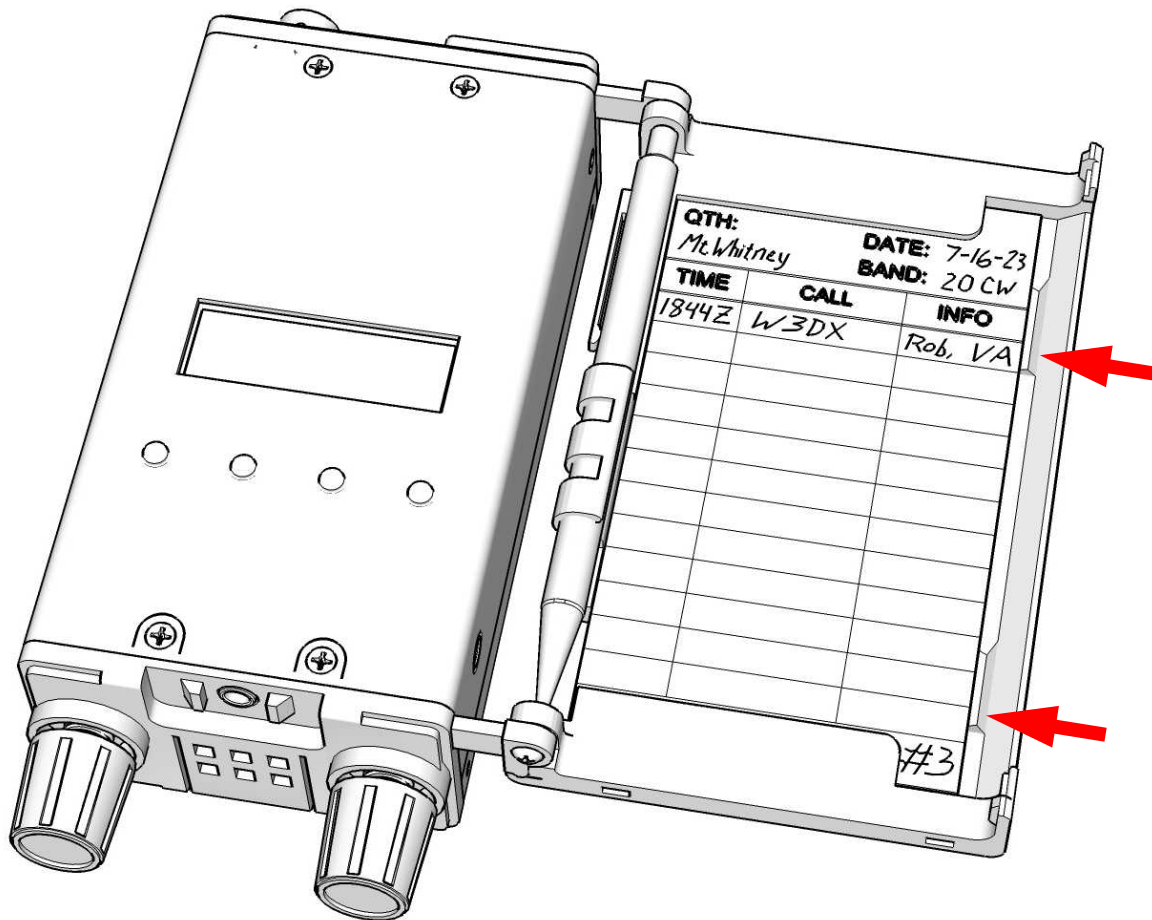

## To use the log tray:

- If the tray was not factory-installed, or if you'd prefer to re-mount the tray on the left side, refer to the instruction sheet on our KH1 manuals web page.
- Print out and precisely trim the desired number of log pages from the file KH1LOGSHEETS.PDF, available on our KH1 web page. We recommend keeping 12-15 sheets in the tray, as this stack thickness will provide a friction fit within the upper and lower paper guides.
- To open the tray, use a thumbnail to unsnap the clips at the top and bottom edges, then unfold the tray to the position shown above. Detented arm joints hold the log open. The arms also slide out to provide additional clearance for your fingers when operating the KH1 hand-held.
- Unclip the supplied mini ball-point pen to log contacts, record field observations, etc. **Note:** If you use a Space Pen instead, remove its metal pocket clip to improve the fit.
- To change log sheets, slide one sheet off the top, then insert it under the stack, starting with one corner. Indentations are provided for this purpose at the locations shown above (see arrows).



# ANTENNAS

The basic KH1 has a BNC jack intended for use with a 50 ohm load, e.g. a resonant dipole, vertical, or end-fed half-wave. Further information on antennas can be found in the *ARRL Antenna Handbook* and other sources.

**i** Since a basic KH1 does not include the whip, hole plugs are installed at the mounting post and switch.

## BUILT-IN ATU AND WHIP MATCHING NETWORK

The ATU option (KHATU1) greatly enhances the KH1's versatility. It includes:

- an automatic antenna tuner unit (ATU) that works with both the BNC jack and whip
- internal whip-matching network for use on 20/17/15 meters (30 m at higher SWR / lower power)
- telescoping whip, plus two clips that retain the whip on the side of the KH1 when not in use
- 13' counterpoise wire suitable for 30-15 m use (with the ATU)

**i** Like the log tray, the plastic whip clips can be installed on either side of the transceiver, facilitating left- or right-handed operation. Refer to instructions on our KH1 manuals web page.

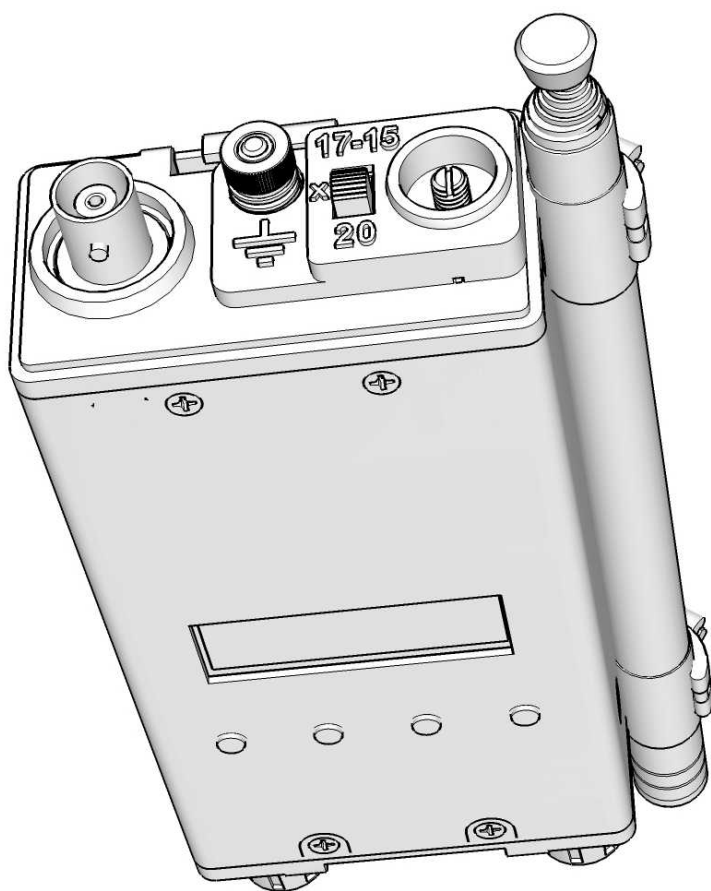

### To use the BNC jack:

- Set the whip band switch to the center-off position (“x”) to remove RF from the whip mounting post.
- The ATU may provide a better SWR, as well as allowing operation on multiple bands. See pg. 17.

### To use the built-in whip:

- Unclip the whip from the radio.
- Screw it to the mounting post.
- Set the slide switch to the 20 m or 17/15 m position. For 30 m, use the 20 m position (reduced output).
- Attach the supplied counterpoise wire to the ground screw, and deploy the wire (on the ground, across bushes, etc.).
- Short whip antennas may exhibit wide swings of SWR with frequency and varying terrain. The ATU can compensate for these factors. Refer to the next page for operating tips.

**⚠** It is normal for the whip mounting post to have some “play” when a whip is not connected. The post is pinned internally so that it cannot rotate or be extracted. When a whip is attached, it will be very rigid and stable.

## TIPS FOR USING COMPACT ANTENNAS

The built-in whip can be deployed in seconds and takes very little storage space. It allows your entire KH1 multi-band station to disappear into a small pocket. However, a whip will not be as efficient as a longer antenna mounted well above ground.

Rising to this challenge is half the fun...and the tips below can improve your QSO rate. It's possible to make long-range DX contacts using low power and a whip, especially with advantageous propagation. Contacts of 1,000 to 2,000 miles are quite common.

### To enhance communications effectiveness when using a whip:

- **ALWAYS use a counterpoise wire.** Without one, your transmitted signal strength will be as much as 20 to 30 dB lower at receiving stations, even if you get an apparent good match using the ATU.
- **Bring extra wire for outings when band conditions are rough.** If there are trees available, a random-wire antenna can be quickly deployed, then matched using the ATU. A BNC-to-binding post adapter (e.g. Elecraft #BNC-BP) can be used to attach an antenna wire to the BNC jack.
- **Choose locations with an upward slope behind you.** This can work as a reflector.
- **Arrange your ground counterpoise wire for greatest benefit.** Deploying the wire toward the favored direction often improves signal strength by several dB, as can draping the wire on top of foliage. You can use the ATU to compensate for changes in wire position and terrain.
- **Use the Reverse Beacon Network (RBN).** This is a global network of receiving stations that may detect your signal and report it on their website. It's a great tool for optimizing antennas.
- **Try working strong stations first (S7 or higher).** While some stations may be strong due to amplification, more often it's because of favorable propagation. Also, they typically use low-loss antennas with gain, making them louder — while allowing them to hear you better as well.
- **Drop in on the QRP “watering holes.”** There are QRP calling frequencies, such as 14060.0 kHz, that are used for weak-signal CW work. “HF Pack” operators will often monitor or call on 18157.5 kHz and other standard HF pack frequencies in both SSB or CW modes. Another active group that listens for weak signals is the *County Hunters Net*, around 14055 kHz.
- **Plan outings around times when band activity is high,** including weekday evenings, weekends, and whenever contests are in progress. Contest examples: CQ DX, ARRL CW, and other “majors”; ARRL Field Day, Winter Field Day (WFD) and other contests emphasizing QRP/field operation; and CWT (very active weekday CW operating events put on by the CWops organization).
- **Try SOTA (Summits On The Air) and POTA (Parks On The Air) operation.** These activities are very popular. SOTA in particular uses a limited frequency range and in most cases low power. “Chasers” (SOTA) or “Hunters” (POTA) will be looking for you, and your outings can be pre-announced. (Given the small size and weight of the KH1, some early KH1 users coined the phrase “Diet SOTA.”)

## GROUND CONNECTION AND COUNTERPOISE WIRE

A counterpoise wire can be secured to the KH1 using the ground screw beside the BNC jack. The wire can be wrapped around the KH1 and left attached to the ground screw to enable quick deployment.

The KHATU1 option is supplied with a 13' counterpoise wire suitable for use on 20-15 meters. The ATU can be used to achieve resonance and compensate for varying wire lengths, heights, and terrain.

The ATU option also comes with two plastic “whip clips” that double as attachment points for the free ends of antenna or ground wire, as well as headphone cables. The arrow in the illustration below-left highlights the serrated gap on one of the whip clips. A wire or thin cable inserted into this gap will be securely retained during transport.

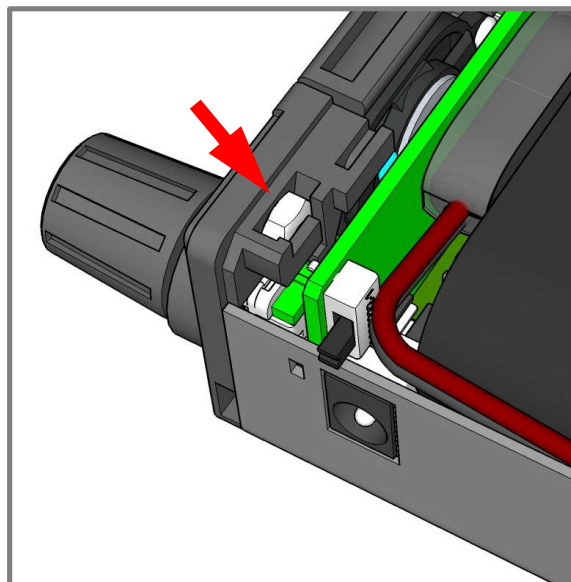
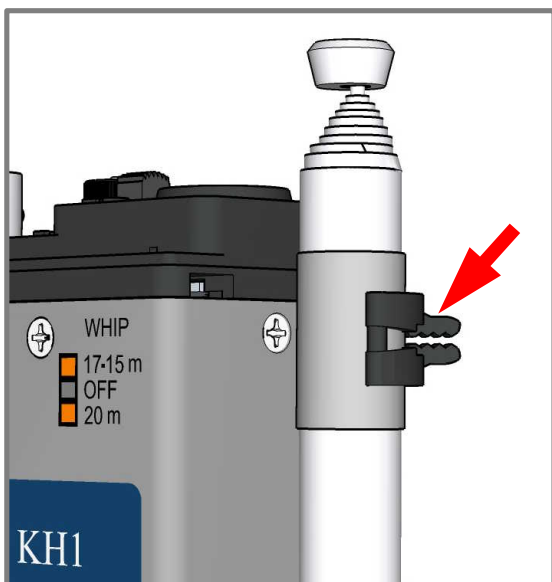

## SPARE GROUND NUT

If the regular ground thumb nut becomes lost, the supplied spare ground nut can be used. This 4-40 hex nut is stored inside the enclosure near the on-off switch, as shown by the arrow in the illustration at above-right. This nut can be pried upward out of its retaining clip using any small tool, including the paddle hex wrench, which is stored nearby (see KEY/DATA JACK, pg. 12).

**⚠ Turn the KH1 OFF when removing the spare ground nut or hex wrench.**

## CARRYING CASE

The ES20 custom carrying case is shown below (actual color is black). It provides safe storage for the KH1, headphones, spare battery packs, antenna wire, whip, and other small accessories. The ES20's numerous straps, two D rings, and carabiner add attachment versatility. For example, it can be worn on a belt, vertically. With one hand, the zippered main pocket can then be opened and the radio extracted.

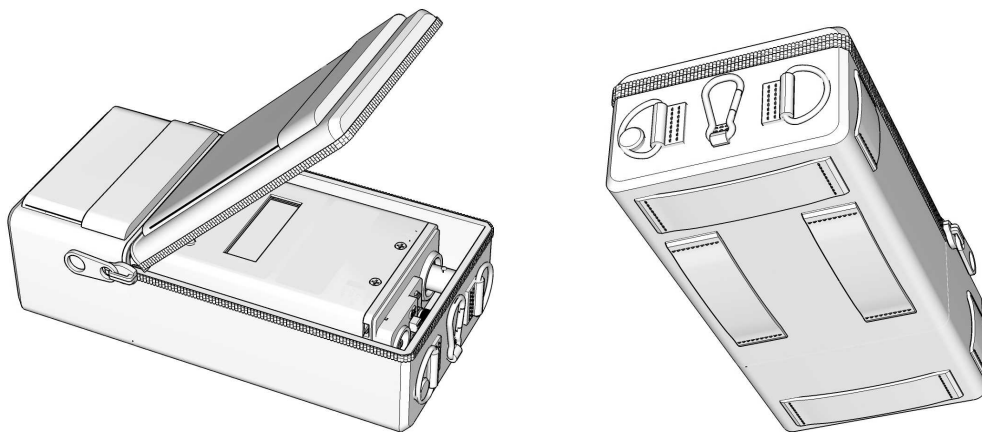

## KEY/DATA JACK

A keying device fitted with a 3.5 mm (1/8") **stereo** plug can be plugged into the KEY/DATA jack. This jack doubles as serial port for firmware updates and remote control (see next page).

The optional KHPD1 keyer paddle is designed specifically for hand-held operation. It plugs directly into the KEY/DATA jack in the orientations shown below. At left, the KHPD1 is shown in its stored position. At center, the paddle is shown deployed, out of the way of the AF GAIN and VFO knobs.

**⚠ Be sure to insert the paddle's plug all the way, so that it snaps into the jack. The paddle's PC board must be resting on the two plastic nubs to the left and right of the jack.**

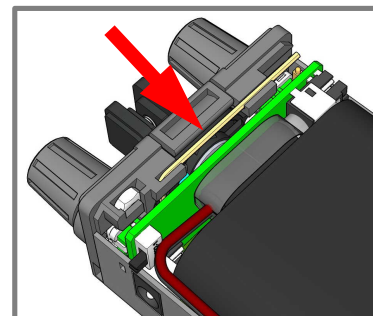
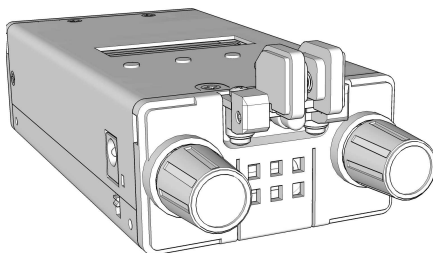
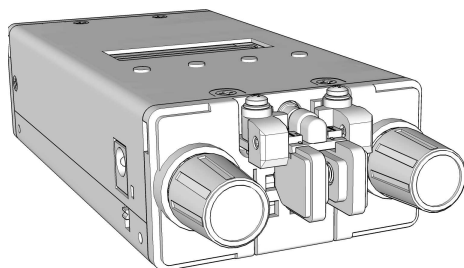

**Contact spacing of the KHPD1 paddle can be adjusted using the hex wrench stored inside the enclosure (see arrow in the illustration above-right). Each paddle has a set screw in its housing. A fairly wide spacing is recommended for operation in high-vibration or less-stable operating positions.**

**⚠ Turn the KH1 OFF when removing or replacing the hex wrench.**

## DATA CONNECTION

The KEY/DATA jack doubles as a serial interface port for upgrading firmware, via the supplied KXUSB cable and our *KH1 Utility* software application. (*MENU:KEY JACK* must be set to RS232; the KXUSB cable converts this to USB. The serial interface data rate is fixed at 9600 baud.)

The KH1's user interface can be fully remote-controlled through the KEY/DATA port, using a terminal emulator or custom software application. This capability is intended for factory alignment use, but it could also be used for special applications. (For a list of remote-control commands, refer to the *Elecraft KH1 Programmer's Reference*.)

**i** When the KEY/DATA jack is being used for remote control, it is not available for use with a keying device. However, there's a remote-control command (HK) that can be used to simulate CW keying, as if using a hand key. This command is used during factory alignment. It could also be used for on-air CW transmission, replacing the key or paddle. The software application would be responsible for ASCII to CW translation and/or could provide its own keying input device.

## HEADPHONES AND SPEAKERS

The 3.5 mm PHONES jack accommodates headphones or an externally amplified speaker. A **stereo** plug must be used in all cases. If the log tray is installed on the same side as the headphone jack (which is the case for right-handed operators), a small-format, right-angle headphone plug will be needed to avoid interference with the log tray during operation.

**Headphones are preferred for outdoor use**, especially when wind or other noise sources are present. However, the KH1 does include a small speaker, with good bass response and about 0.5 W peak power output. The speaker is located below the KEY/DATA jack.

**i** When using the speaker, strong signals and/or high AF GAIN settings can result in signal clipping at peaks. If strong signal levels cause a significant increase in average receive current drain, firmware will automatically back down AF gain to a safe level.

## DISPLAY

The KH1 uses an alphanumeric LCD with two lines of 16 characters. The display is backlit at all times, consuming only 6 mA of current while making the display easily readable under any lighting conditions.

The KH1 FRONT PANEL QUICK REFERENCE (next page) shows the normal operating display. Subsequent sections show examples of all the different displays used.

With most switch functions, the LCD is divided into four columns that correspond to the four push-button switches below it. In such cases, the upper line of the LCD shows switch *tap* functions, while the lower line shows *hold* functions. (This is presented in detail on pg. 16.) Small white and yellow squares to the left of the display and switches serve as a reminder of this relationship.

# KH1 FRONT PANEL REFERENCE

**BNC jack** is for most antennas (AX1, dipole, random wires, etc.). Both WHIP and BNC jacks are routed through ATU.

**WHIP slide switch** selects 20 m or 17-15 m. Set to OFF when using BNC.

**WHIP post** is used with 4' whip antenna. Loading coil is built-in.

**LCD upper line** shows VFO, mode, RIT/XIT, and tuning indicator

**LCD lower line** shows S-meter, atten icon, filter number, battery status, ATU icon, and UTC or local time

**SPD-/+: WPM up/dn**

**RCVR:** FL1-3, atten. 0/-10/-30 dB, RIT

**PFn/XMTR:** PF1-3, TUNE, power level, TX TEST, XIT

**ON/OFF** slide switch and internal charger LED

**AF/MON** knob *tap* sets AF gain and sidetone level/pitch; *hold* turns on SPOT tone

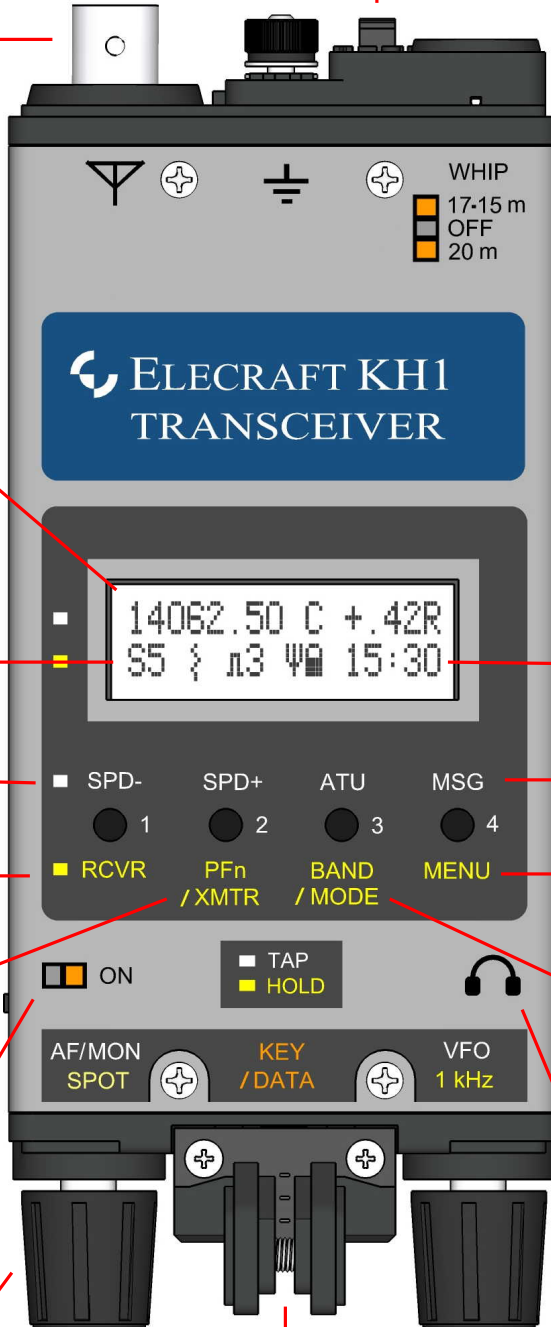

All **pushbutton switches** and **knobs** have *tap* (white) and *hold* (yellow) functions. When sub-functions are shown on the LCD, *tap* to change those on the upper line; *hold* for lower line.

**Alternate LCD lower line** (*MENU:DISP MODE*) shows: voltage, current, PA temp. Lower line also shows text decode (*MENU:TEXT DEC*).

**ATU:** ATU tune; **MSG:** 1-3

**MENU:** Used for setup and calibration functions

**BAND/MODE:** Band select (40-15 m and SWL), mode, and memories (V/M, V>M)

**Plugging in phones** turns off internal speaker

**VFO** knob *tap* selects 10/100 Hz tuning rate; *Hold* selects 1 kHz rate

**KEY/DATA** jack is used with KHPD1 or other key; used as data port for F/W updates, remote ctrl.

## BASIC OPERATION

This section describes basic KH1 operation in tutorial fashion. We recommend trying each of the controls. For a 1-page summary of controls, refer to the front panel reference (pg. 14).

**i** Before using the KH1, connect a power supply and antenna, at minimum. See pages 5 and 9.

### TURNING THE KH1 ON/OFF

To turn the KH1 on or off, use the small slide switch near the external supply jack on the left side. When you turn it on, the initialization screen should appear for about 2 seconds:

```
ELECRAFT
KH1
```

followed by the normal operating display. Line 1 shows VFO frequency, mode letter, and RIT/XIT offset. Line 2 shows the S-meter level, filter bandwidth, battery charge status icon, and time.

```
14000.00 C +.00
S0  11  00:00
```

If you see an error message, refer to [APPENDIX A](#).

### SWITCH TAP AND HOLD FUNCTIONS

All KH1 switches have two functions:

- *Tap* to activate the function labeled above a switch, in white. Tap functions are denoted with a white box, e.g. **SPD-**.
- *Hold* for over 0.5 seconds to activate the function labeled below a switch, in yellow. This is shown by a black box, e.g. **RCVR**.

The four pushbutton switches are also referred to as **1-4** (*taps*) or **1-4** (*holds*) when they're used to perform functions shown on the display.

## VFO KNOB FUNCTIONS

The right-hand knob controls the VFO. *Tapping* this knob—i.e., briefly pushing it inward—alternates between 10 Hz and 100 Hz tuning steps. This is denoted as **⊗ VFO** (a knob icon, plus a white box indicating a *tap* function).

**i** The 100 Hz step size can be changed; see *MENU:VFO FAST*.

*Holding* the VFO knob in for over 0.5 seconds selects 1 kHz tuning steps (**⊗ 1 KHZ**) until the knob is tapped again to cancel.

**i** When the **BAND/MODE** switch function is in use, the VFO knob can be used to change VFO frequency in 100 kHz steps.

## AF/MON KNOB FUNCTIONS

The left-hand knob (AF/MON) normally controls AF gain (**⊗ AF**). As you rotate the knob, the new setting is displayed briefly on line 1 of the display.

*Tapping* the AF/MON knob switches to its **⊗ MON** function (MONitor). Sidetone volume level is displayed on line 1 and sidetone pitch on line 2:

```
A⊗ MON 03
V⊗ PITCH 600 Hz
```

The A⊗ in line 1 indicates that the **AF** knob sets sidetone level. Similarly, the V⊗ in line 2 indicates that the **VFO** knob sets sidetone pitch. (The center pitch of the receiver tracks the sidetone pitch.) Tap any control to restore the AF gain function.

*Holding* the AF/MON knob switches to the receiver spotting function, or (**⊗ SPOT**). This allows the VFO knob to be used to tune in a signal to match your sidetone pitch. **SPOT** will be shown on line 2 of the display until the spotting function is cancelled by any control tap.

## DISPLAY MAPPING TO SWITCHES 1-4

Functions shown on the display are often mapped to one or more of the pushbutton switches. This provides access to up to 8 functions, each with a single switch press: 4 via a *tap*, and 4 via a *hold*.

In the example below, T1 - T4 correspond to taps **1**–**4**, and H1 - H4 correspond to holds **1** - **4**.

T 1	T 2	T 3	T 4
H 1	H 2	H 3	H 4

## RECEIVER CONTROLS

After holding the **RCVR** switch, the LCD shows:

FL 1	FL 2	FL 3	[ x ]
0 dB	- 10	- 30	RIT

Tap **1**, **2**, or **3** to select filter bandwidths; tap **4** to exit without making changes. Hold **1**, **2**, or **3** selects attenuation levels; hold **4** to turn on RIT.

**ATTENUATOR:** When the attenuator is set to -10 dB, a resistor icon appears on line 2 (assuming *MENU:DISP MODE* is set to Operate):

14000.00	C	+	.00
S0	⏏	1	00:00

The -30 dB setting uses a thicker resistor icon. In the 0 dB setting, the icon character is blank.

**S-METER:** The S-meter shows S0-S9 (6 dB/unit), then: “+” = S9+10, † = S9+20, ‡ = S9+30.

**RIT:** When RIT is on, an **R** appears to the right of the RIT/XIT offset on line 1. The VFO knob then controls the RIT offset. The offset can be zeroed using a menu function (see *MENU:RIT CLEAR*). RIT is used to change your receive frequency without affecting your transmit frequency – useful for fine-tuning stations after you call CQ.

## PFn AND TRANSMITTER CONTROLS

Holding **PFn/XMTR** shows 8 selections:

PF 1	PF 2	PF 3	[ x ]
TUN	PWR	TST	XIT

Tap **1**, **2**, or **3** to execute a programmable function (see pg. 19). Tap **4** to exit.

Hold **1** to put the transmitter into TUNE mode. Hold **2** to select LO (~2 W) or HI (~5 W) power level (pg. 19). Hold **3** to put the transmitter into TX TEST mode, used for CW practice (no RF out).

**XIT:** Hold **4** to turn on XIT, which adds an **X** after the RIT/XIT offset. XIT offsets your transmit frequency without affecting your receive frequency. This is useful when calling DX stations who specify “UP 2” (etc.) when they call CQ.

## BAND AND MODE CONTROLS

Holding **BAND/MODE** brings up this display:

[ - 14 . 0 + ]	V/M	[ x ]
[ - CW + ]	V>M	[ L ]

To change bands, tap **1** (-) or **2** (+). The last band, above 15 m, is used for general coverage (pg. 20). You can use the VFO knob to adjust frequency in 100 kHz steps while in the band/mode display.

To change modes, hold **1** (-) or **2** (+). Use SSB modes to copy AM. Also see SSB/CW CROSS-MODE OPERATION, pg. 20.

Tap **3** (V/M) to exchange the present VFO frequency with the scratchpad Memory. Hold **3** (V>M) to copy the VFO to memory. The memory holds frequency, mode, and attenuator settings.

Tapping **4** exits without further changes. Holding **4** locks (or unlocks) the VFO. VFO locking is especially useful when negotiating rough terrain.



## KEYER SPEED CONTROLS

Tapping **SPD-** or **SPD+** changes the built-in keyer speed. This can be done while sending, including during message playback.

Slower code speeds (16-24 WPM) are recommended with QRP operation in general, and in particular when operating with small antennas and/or pedestrian mobile (/PM).

## ATU TUNING

Tapping **ATU** causes the antenna tuner, if installed, to look for the best match to the attached load. You'll hear relays switching for 1 to 4 seconds. The ATU settings are stored on a per-band basis and recalled automatically when you change bands.

If SWR is very high (> 3:1) after matching with the ATU, consider making length or other adjustments to the antenna or counterpoise. Tap **ATU** again afterward. SWR is shown continuously on a bar graph as you key the transmitter. 1 solid block = close to 1:1, 2 blocks = 2:1, etc. Unfilled blocks indicate half of an SWR unit, so 1 solid and one unfilled would equate to about 1.5:1.

**i** The miniature ATU module in the KH1 has fewer L and C components than in the Elecraft KX2 and KX3 ATUs. This means it will not always find a very low SWR. In most cases it will be under 3.0, which still ensures excellent power transfer. The transmitter's PA device is very resilient to even higher SWR values, and it can be operated into virtually any load. However, if reflected power is excessive, the KH1 will automatically drop into Low Power mode. (See *MENU:ADJ PWR* for details on setting power levels.)

**i** The KH1 ATU does not need a "second-tap within five seconds" feature to try more L-C combinations. The ATU keeps trying until all combinations have been tested, or one is found that provides an SWR of 1:1.

## MESSAGE PLAY / RECORD CONTROLS

Tapping **MSG**, followed by **1** - **3**, plays stored message buffers. To auto-repeat, *Hold* rather than *tap* the message number (i.e., use **1** - **3**). *MENU:MSG RPT* sets the message repeat interval. If you play a message while one is already playing, it will be *chained* on at the end.

To record a message, hold **MSG**, then tap **1** - **3**.

## USING THE MENU

The menu is not required for basic operation. However, it does provide access to advanced features, so we encourage you to review all menu entries after you become familiar with the basics.

To enter the menu, *hold* the **MENU** switch. This brings up the default menu entry, DISP MODE:

```
A⊗ DISP MODE [x]
V⊗ Operate
```

The AF/MON knob is used to scroll through menu entries (shown by A⊗ at the start of line 1). The VFO knob is used to change parameter values (V⊗). To exit, tap **4** as indicated by [x] on line 1.

The DISP MODE menu entry selects the mode for line 2 of the display. The default mode is **Operate**, showing S-units, filter bandwidth, icons, and time. The alternate mode for line 2 is **V/I/Temp**, which shows the supply voltage, current drain, and PA device temperature in degrees C.

**i** All alignment menu entries start with "ADJ" (short for "adjust"). They're at the top of the list.

# ADVANCED FEATURES

## SCAN/MINI-PAN

The KH1 includes a band-scanning function with visual display of signal level across the selected tuning range. This is especially useful for hands-free signal search when bands are quiet.

### Scan/mini-pan setup:

- Make sure the threshold comparator menu entry is set to the ideal value. See instructions at *MENU: PAN THR*.
- Tune the VFO to approximately the middle of the range of interest. For example, if you were monitoring 20 meters for SOTA activators or other QRP stations, you might set the VFO to 14060 kHz.
- Set *MENU: PAN SPAN* to the desired total scan range (default: 10 kHz). Smaller spans will provide a faster scan rate and better frequency resolution.

### Scan/mini-pan operation :

- Set *MENU: PAN MODE* to ON and exit the menu.
- The scan/mini-pan will appear. This captures the VFO, so normal tuning is disabled until you tap any switch. Audio will still be enabled during the scan, resulting in “blips” as signals go by.
- If a signal of interest shows up in the scanned range, either visually or audibly, you may wish to stop the scan and tune the signal in. **Note:** weak signals may be audible without showing a visual indication.
- If you use this feature frequently, consider assigning the *PAN MODE* menu entry to one of the user-programmable functions.

## USER-PROGRAMMABLE FUNCTIONS

Menu entries *PF1 FUNC*, *PF2 FUNC*, and *PF3 FUNC* can be used to assign menu entries to user-programmable functions PF1, PF2, and PF3. Once assigned to menu entries, these three functions can be accessed by first holding the **PFn/XMTR** switch, then tapping **1**, **2**, or **3**.

**i** When a PFn function is assigned, a 3-character version of the menu entry name replaces the original **PFn** label. This serves as a reminder of the menu entry. These 3-character shorthand labels are shown in the menu listing.

### Example: Using PF1 as a DISP MODE short-cut

To set up PF1 to access *MENU:DISP MODE*:

- Hold **MENU**, then use the AF/MON knob to locate the *PF1 FUNC* menu entry.
- Use the VFO knob to change the *PF1 FUNC* parameter to DISP MODE.
- Exit the menu.

Having set up PF1, you can now use it as a short cut:

- Hold **PFn/XMTR**. Line 1 will now show 4 tap options: **DSP PF2 PF3 [x]**. (Note that **DSP**, the 3-character shorthand name for DISP MODE, has replaced **PF1**.)
- Tap **1** to switch display modes. This restores the normal display, except line 2 of the LCD will now show V/I/Temp info.

**i** Using a PFn function that's assigned to a "binary" (2-valued) menu parameter selects the alternate value, then restores the normal display. For menu entries with more than two values, a PFn function will enter and remain in the menu.

## REAL-TIME CLOCK

The real-time clock is useful for logging, whether on paper or using the KH1's built-in logging function (*MENU:LOGGING*), which automatically time- and date-stamps transmitted text.

Time is shown as HH:MM on line 2, if *MENU:DISP MODE* is set to Operate.

To view or set the time (HH:MM:SS), use *MENU:ADJ TIME*. To view or set the date, use *MENU:ADJ DATE*. Long-term RTC error correction is possible using *MENU:ADJ RTC*.

## CUSTOMIZING POWER LEVELS

The factory-set levels for LO and HI power are about 2 W and 5 W, respectively. These can be changed using *MENU:ADJ PWR*.

**i** The KH1 does not use ALC (automatic transmit level control). Actual power output will vary with load SWR and supply voltage.

**The recommended HI power level is 5 or 6 W into 50 ohms** when running from an 11.0 V supply or battery pack. Higher levels may be possible, but this may compromise the CW keying envelope or increase PA device heating.

**The recommended LO power level is 2 W minimum.** This is sufficient to provide stable SWR readings when using the ATU. Below this level, SWR readings may be artificially low. The ATU uses whichever power level is selected by the user. HI power will result in more accurate matching in some cases.

**⚠** If any transmit measurement is excessive, including current, reflected power, or temperature, the KH1 will automatically drop to the low power level. If this does not decrease the readings sufficiently, transmit will be exited.

## TEXT DECODE AND DISPLAY

When text decode is enabled for either transmit or receive, it is displayed on line 2 of the LCD as it comes in. After a period of inactivity, the regular line 2 display will be restored.

### Transmit Text Decode

The KH1 can decode and display your transmitted keying, assuming you're using the built-in keyer. To enable this, set *MENU:TEXT DEC* to any setting other than OFF. Use The TX-Only setting if you don't need to decode received CW.

**i** If automatic logging is turned on, but TEXT DEC is set to OFF, the TEXT DEC setting is internally treated as TX-Only. This is necessary to decode and log your transmitted text.

### Receive Text Decode

Moderate to strong received CW signals can be decoded and displayed. In this case set *MENU:TEXT DEC* to TX and RX.

Decoding performance will vary with signal strength, interference, and signal-to-noise level. For best results use the narrowest filter setting (FL1).

## CW/SSB CROSS-MODE OPERATION

If you set the KH1's operating mode to LSB or USB, you can copy SSB signals, but transmit will still occur as CW. This is referred to as "cross-mode" operation. It is occasionally used by QRP stations to log into nets, or to make contacts on HF Pack calling frequencies, particularly 18157.5 kHz. Of course it could also be used in an emergency. (**Note:** Not all SSB operators are proficient at CW. Use slower code speeds.)

When operating cross-mode, SSB listeners will hear your CW signal as a 700 Hz tone.

## GENERAL COVERAGE RECEIVE

Thanks to its electronically tuned RF band-pass filter, the KH1 provides general coverage from 6.7 to 22.0 MHz via a separate SWL band. This band can be selected using **BAND/MODE**. It's just above 15 meters in the rotation.

**i** SWL is an abbreviation for Shortwave Listening.

All KH1 operating modes are available on SWL bands. To copy AM signals, use LSB mode. USB is also usable, but crystal filters of the type used in the KH1 produce a slightly "warmer" passband and better image rejection when LSB is used.

RIT and XIT are disabled on the SWL band. Instead, the RIT/XIT offset value is replaced with **SWL** as a reminder.

### Improving General-Coverage Sensitivity

During factory calibration, the RF bandpass filter (BPF) is optimized only on ham bands. SWL values are set to approximate defaults.

You can manually optimize general-coverage frequency segments of interest if required. To do this: (1) Connect an antenna (a long random wire is ideal). (2) Select the SWL band. (3) Tune the VFO to the middle of a 100 kHz segment of interest. (4) Use *MENU:ADJ BPF* to peak the received signal or noise.

Although transmit and automatic antenna tuning are not allowed when using the SWL band, you can optionally peak up received signals with the ATU using *MENU:ATU PARAM*. (This is discussed further at MANUALLY TUNING THE ATU, pg. 21.)

If you're using a wire that's  $\frac{1}{4}$  wavelength or longer on the target frequency, receive sensitivity will generally be adequate without peaking the ATU. In this case you can simply bypass the ATU using *MENU:ATU MODE*.

## MANUALLY TUNING THE ATU

You can directly view and change the automatic antenna tuner's settings using the *ATU PARAM* menu entry. Inductance and capacitance values are shown, and each can be independently moved up or down using the VFO knob. The impedance-selection setting (Z) can also be viewed/changed.

This feature is useful for peaking receive signals without transmitting. When operating in ham bands, it's much faster to let the ATU do the work by tapping the **ATU** switch. But transmit is not allowed when using the SWL band, so manual adjustment of the ATU is the only option.

Typically the C (capacitance) value would be set to 0 and the inductance varied until a peak is found. Then, if further optimization of signal strength is desired, some capacitance is inserted. When capacitance is non-zero, both the LO and HI impedance settings (Z) should be tried.

For further details see *MENU:ATU PARAM*.

## AMPERE-HOUR METERING

The KH1's Ah reading is shown as part of the *VBAT* menu display. This is useful for testing battery packs, estimating remaining battery charge, or tracking the Ah needed to complete one or more objectives (e.g., a certain number of QSOs at a given power level). The value is preserved on power-off, so it can show amp hours used over any number of operating sessions.

Holding CLR resets the value to 0.000; this is typically done after swapping in a fresh battery.

## BUILT-IN LOGGING

The KH1 can be configured to continuously log all of your transmitted CW in a text file. This may be used as an alternative to paper logging, or as a backup method.

Up to about 32,000 characters can be captured, along with time, band, and mode, so you can update a paper or electronic logbook later on.

To enable logging, set *MENU:LOGGING* to ON. Logging applies only when using the internal keyer. To take advantage of time stamping, set the built-in clock's time and date (*MENU:ADJ TIME* and *MENU:ADJ DATE*).

When logging is enabled and there's room available, the mode letter (on line 1 of the LCD) flashes slowly. Outgoing text decode is turned on automatically. If you fill the log, LOG FULL is flashed.

For details on viewing, erasing, and downloading log data to a computer, refer to *MENU:LOGGING*.

## INITIALIZING PARAMETERS (EEINIT)

The KH1 has 1K of EEPROM (non-volatile) memory dedicated to configuration storage. This includes calibration data, menu settings etc.

If configuration data becomes compromised for any reason, you can reset it to defaults using *MENU:EE INIT*.

**⚠ The EE INIT menu entry can be used to reinitialize ALL of the KH1's stored parameters, or just the OPERATIONAL parameters. Refer to the menu entry for detailed instructions.**

**If a full EE INIT is done, factory calibration settings will be lost, making a full recalibration necessary. To avoid this, try an OPERATIONAL EE INIT first.**

## UPDATING FIRMWARE

There are two reasons to update the KH1's firmware:

- the KH1 failed its power-up test of the microcontroller firmware, and is displaying **UTILITY?** on the LCD
- there's new firmware available with features or bug fixes of interest

### To update firmware:

Unplug the keyer paddle, then plug in the supplied KXUSB cable. The other end must be connected to a USB-A port on a host computer (or to a USB-A to USB-C adapter, etc.). You'll then need to run our *KH1 Utility* program, available on our KH1 web page.

**If the KH1 is displaying UTILITY**, then it will already be configured to use the KXUSB cable, ready for *KH1 Utility* to be run. The utility will prompt you to begin the firmware download process.

**If you're doing a normal firmware update**, locate menu entry *KEY JACK* and change the setting to RS232. Then run *KH1 Utility* and follow the instructions in its help function.

In both cases, the KH1 will show **LOADING** on line 1, and a progress bar on line 2 during firmware load.

### FORCED DOWNLOAD

If you can't operate the KH1 because of a "hang" condition, try initiating a **forced firmware load**.

To do this, hold the **2** switch while turning the KH1 on. This should force it into the boot loader, where it will show **UTILITY?** You can then proceed as explained above.

## REMOTE CONTROL

The KH1 supports full remote control of its user interface. This capability is primarily intended for updating firmware and for automated factory alignment. But it could also be used to operate the radio using custom software, in applications ranging from controlling a KH1 in a backpack to putting the rig at an antenna's feed point.

For further information on remote control, please refer to the *KH1 Programmer's Reference*.

### COMPUTER INTERFACE

The KH1 is remote-controlled through its KEY/DATA jack using a KXUSB cable and a terminal emulator or software application. *MENU:KEY JACK* must be set to RS232. The serial interface baud rate is 9600 baud (fixed).

When the KEY/DATA jack is being used for remote control, it is not available for use with a keyer paddle or hand key. However, there's a host command (HK) that can be used to simulate CW keying, as if using a hand key. This is used during manual or factory alignment procedures, but it could be used for CW transmission, replacing the key or keyer paddle. The software application would be responsible for ASCII to CW translation and/or could provide a keying input device.

## CONFIGURATION

Numerous menu entries are provided to personalize your KH1. These are set to typical default values at the factory.

The menu entries most often modified by KH1 users are listed below. If you change a value frequently, consider assigning the associated menu entry to a programmable function switch.

ADJ TIME	Clock time (used for logging)
ADJ DATE	Calendar date (used for logging)
ADJ RTC	Optional RTC accuracy adjustment
ADJ PWR	Per-band hi/low power levels
ATU MODE	ATU bypass/auto
DISP MODE	Operate or V/I/Temp for LCD line 2
KEY IAMB	Iambic keying mode
KEY JACK	Paddle normal/reverse/hand key (or RS232 for firmware updates)
LOGGING	Automatic logging on/off/viewing
MSG RPT	Message repeat interval
PAN MODE	Scan/mini-pan feature (pg. 18)
PFn FUNC	User-programmable functions
RIT CLEAR	RIT/XIT offset clear; can only be used with a PFn function
TEXT DEC	TX and RX text decode control
VBAT	Battery voltage, Ah measurement
VFO FAST	Sets the faster of the two normal VFO tuning rates (100 Hz, 200 Hz, etc.)

## ALIGNMENT

Alignment of the KH1's transmitter and receiver is done by the factory. If you have suitable test equipment and want to touch up any of the parameters on your own, be sure to perform the alignment steps in the order listed below.

### RECEIVER

- Calibrate the synthesizer reference frequency (*MENU:ADJ REF*).
- Optimize BFO frequency for filter FL1 for best sensitivity (*MENU:ADJ BFO*).
- Set the onset of AGC action at the mixer (*MENU:ADJ AGC*).
- Maximize receive sensitivity (*MENU:ADJ BPF*) at 7.05, 7.15, 7.25, 10.0, 14.0, 18.0, and 21.0 MHz. Then duplicate the 10.0 setting at 10.1; duplicate the 14.0 setting at 14.1/.2/.3; duplicate the 18.0 setting at 18.1; duplicate the 21.0 setting at 21.1/.2/.3/.4. NOTE: BPF alignment of the general coverage (SWL) band is optional, and can be done at specific 100 kHz segments of interest.
- Calibrate the S-meter (*MENU:ADJ SMTR*).

### TRANSMITTER

**i** The first two steps below require that the front panel be removed.

- Set PA bias current (*MENU:ADJ BIAS*).
- Null the SWR bridge trimmer capacitor (*MENU:ADJ SWR*).
- Calibrate the watt meter (*MENU:ADJ WMTR*).
- Calibrate the low- and high-power settings (*MENU:ADJ PWR*).

# MENU FUNCTIONS

Menu entries are shown in alphanumeric order in the table below.

Each entry has a regular name used in the menu, plus a 3-character shorthand name in braces, e.g. {AGC}. Shorthand names are used as a tag for user-programmable functions (see pg. 19). They're also used with the KH1's "MN" remote-control command, which opens the selected menu entry. Refer to the *Elecraft KH1 Programmer's Reference* for details.

MENU ENTRY & DEFAULT	DESCRIPTION
ADJ AGC V {AGC} 0	Sets onset of AGC action by adjusting DC bias at the base of transistor Q10. <b>To set the AGC voltage:</b> <ul style="list-style-type: none"> <li>• Unlock the ADJ AGC V menu entry.</li> <li>• With no signal at the antenna jack, adjust the parameter until the AGC DC voltage shown on line 2 (typically 1.3 to 1.4 V) drops by about .02 to .03 V.</li> </ul> <b>NOTE:</b> On power-up, AGC voltage may take 1 – 5 s to stabilize near 1.3~1.4 V.
ADJ BFO {BFO} CW: 9213.80 LSB: 9213.80 USB: 9216.00	Sets BFO offsets, which in turn affect the crystal filter passband. <b>NOTE:</b> This adjustment does not affect actual receive frequency of the KH1, because the BFO frequency is taken into consideration when the LO (local oscillator) frequency is calculated. This means that when the BFO is changed, the pitch of a received signal will not change, so the BFO can easily be adjusted to maximize signal amplitude. <b>To align the BFO frequencies:</b> <ul style="list-style-type: none"> <li>• Put the KH1 into TX TEST mode to prevent possible damage to the signal generator due to accidental transmit. Use <b>XMTR</b> -&gt; <b>TST</b>.</li> <li>• Connect a signal generator to the KH1's BNC jack. Set the sig gen for any convenient test frequency, with amplitude of -90 dBm.</li> <li>• Select CW mode using the mode up/down functions (<b>BAND</b> -&gt; <b>[-MODE+]</b>).</li> <li>• Select filter FL1 (<b>RCVR</b> -&gt; <b>FL1</b>).</li> <li>• Tune the VFO until the received signal pitch matches the sidetone pitch.</li> <li>• Unlock the <i>ADJ BFO</i> menu parameter. Adjust the CW BFO frequency for maximum signal strength. Note this value for subsequent steps.</li> <li>• Exit the menu and switch to LSB mode using the mode up/down buttons.</li> <li>• Re-enter the menu and set the LSB BFO frequency to that used for CW mode. (Further adjustment is subject to operator preference.)</li> <li>• Exit the menu and switch to USB mode.</li> <li>• Re-enter the menu and set the USB BFO frequency to that used for CW, + 2.0 kHz. (Further adjustment is subject to operator preference.)</li> </ul>
ADJ BIAS {BIA}	Used to set PA bias current. The top cover must be removed to access trimmer R9. <b>To set the bias:</b> <ul style="list-style-type: none"> <li>• Remove the top cover.</li> </ul>



	<ul style="list-style-type: none"> <li>• Set AF GAIN to minimum to ensure that RX current drain stabilizes at its no-signal level. (This is required because RX current is subtracted from total current in order to derive the TX bias value.)</li> <li>• Locate a screwdriver compatible with R9. Set R9 fully counter-clockwise.</li> <li>• Scroll to the ADJ BIAS menu entry and unlock the parameter. PA bias will be turned on. The text on line 1 of the LCD will remind the user to adjust R9 for a bias of ~0.20 A, while line 2 shows the <b>actual</b> PA bias current.</li> <li>• Adjust the bias using R9. The acceptable range is 0.18 to 0.22 A.</li> <li>• Tap switch <b>4</b> to exit, which turns PA bias OFF.</li> </ul> <p><b>NOTE:</b> It may be possible to use reduced PA bias to provide a slight improvement in efficiency. However, the PA stage is intended to be biased class AB to ensure adequate gain to reach 5 W on all bands, at low supply voltages.</p>
<p>ADJ BPF {BPF} Value is stored per 100 kHz</p>	<p>Tunes the receive band-pass filter (BPF). The full range is about 6.7 to 22 MHz, tuned by a D-to-A converter. A DAC value is stored for every 100 kHz within this range, though in practice, bands from 10 MHz up can use the same DAC value to cover the entire ham band.</p> <p><b>NOTE:</b> Receive band-pass filter values for the ham bands are set at the factory. If you use the SWL band (the next band above 15 m when using <b>BAND/MODE</b>), you'll need to peak the band-pass filter on each 100 kHz segment you use.</p> <p><b>To fine-tune the BPF voltage for a given 100 kHz band segment:</b></p> <ul style="list-style-type: none"> <li>• Unlock <i>ADJ BPF</i>.</li> <li>• Adjust the parameter while listening to on-air band noise or a weak signal (-100 dBm or lower), or use the signal strength method described below.</li> <li>• Below 10 MHz the best value will be different for each 100 kHz band segment. Above 10 MHz the same value can be used for all 100 kHz segments.</li> </ul> <p><b>Using the Audio Signal Strength Display:</b></p> <p>When the <i>ADJ BPF</i> menu entry is unlocked, line 1 of the LCD shows the relative audio signal level as a 5-digit number. For weak signals that don't activate AGC, this can be used for BPF alignment in lieu of peaking the signal by ear. It also provides a way to measure the MDS of the KH1's receiver, as follows.</p> <p><b>To measure receiver MDS:</b></p> <ul style="list-style-type: none"> <li>• Put the KH1 into TX TEST mode to prevent possible damage to the signal generator due to accidental transmit. Use <b>XMTR</b> -&gt; <b>TST</b>.</li> <li>• Bypass the ATU, if applicable, using <i>MENU:ATU MODE</i>.</li> <li>• Select crystal filter 1 using <b>RCVR</b> -&gt; <b>FL1</b>. (Note: MDS may vary slightly among the three filter bandwidths. FL1's bandwidth is ~300-500 Hz.)</li> <li>• Connect a signal generator to the KH1's BNC jack. Set the sig gen for the desired test frequency, with amplitude of -107 dBm.</li> <li>• Temporarily set <i>MENU:AGC V</i> to 30 to disable AGC on weak signals.</li> <li>• Turn the sig gen ON. Adjust the parameter for peak as indicated by the audio signal measurement. Write down the value (typ.: 00500).</li> <li>• Turn the sig gen OFF and note the lower number (typical: 80).</li> <li>• MDS (in dBm) is equal to: <math>-107 - 20 \log(V\_AF\_sig / V\_AF\_noise)</math>.</li> <li>• Restore the <i>MENU:AGC V</i> parameter to its aligned value (typically 45-50).</li> </ul>

<p>ADJ DATE {DAT}</p>	<p>Used to view/set the RTC's date registers. U.S. date format is used (MM/DD/YY). Set the date if logging will be used (<i>MENU:LOGGING</i>). Also see <i>MENU:ADJ TIME</i>.</p> <p><b>To set the date:</b></p> <ul style="list-style-type: none"> <li>• Unlock the <i>ADJ DATE</i> menu entry.</li> <li>• Tap <b>1</b> to exit, <b>2</b> to set months, <b>3</b> to set days, or <b>4</b> to set years.</li> </ul>
<p>ADJ OSCID {OSC} 0</p>	<p>Selects an MCU I/O address for the local oscillator IC. In most cases the default (ID = 0) will be used. If with this setting the VFO frequency cannot be tuned, or the synthesizer signal appears to be missing, try ID = 1, then ID = 2. (TECHNICAL NOTE: Parameter values 0/1/2 equate to I2C bus address 0x60/0x6F/0x62.)</p>
<p>ADJ PWR {PWR} LO PWR, 0 HI PWR, 80</p>	<p>Sets approximate power output on a per-band, per-power-level basis. The default values correspond roughly to 1 W (LO) and 4 W (HI). (Use <b>XMTR</b> -&gt; <b>PWR</b> to alternate between the LO and HI levels.) Factory settings: LO = ~2 W, HI = ~5 W.</p> <p>NOTE: This parameter actually sets the drive level to the PA transistor, which in turn varies power output. ALC is not used in the KH1, so power output will vary from the selected level when the load impedance is not 50 ohms resistive, or when the battery nears end-of-charge.</p> <p><b>To adjust power output:</b></p> <ul style="list-style-type: none"> <li>• Connect a dummy load to the BNC jack and a paddle key to the key jack.</li> <li>• Make sure <i>MENU:KEY JACK</i> is <b>not</b> set to RS232.</li> <li>• Set the whip band switch on the top panel to the center-OFF position (if applicable). This disconnects the whip toroid from the ATU, reducing stray reactance, and eliminates any RF burn hazard from the whip mounting bolt.</li> <li>• Set <i>MENU:ATU MODE</i> to Bypass, if applicable.</li> <li>• Calibrate the wattmeter using <i>MENU:ADJ WMTR</i> if not already completed.</li> <li>• Locate the <i>ADJ PWR</i> menu entry and unlock it.</li> <li>• Press the hand key or paddle (firmware treats paddles as hand keys while in this menu entry). This will put the radio into TX mode. Adjust the parameter using the VFO knob until the desired power output is obtained.</li> </ul>
<p>ADJ REF {REF} -0.40 kHz</p>	<p>Calibrates the synthesizer reference frequency. Once this is set on any band, all bands will be calibrated. This is factory-aligned to ~ +/- 20 Hz at 25 C.</p> <p><b>To calibrate the reference frequency:</b></p> <ul style="list-style-type: none"> <li>• Put the KH1 into TX TEST mode to prevent possible damage to the signal generator due to accidental transmit. Use <b>XMTR</b> -&gt; <b>TST</b>.</li> <li>• Inject a signal at any convenient frequency (factory: 21.1 MHz).</li> <li>• Select CW mode and tune the VFO to that exact frequency.</li> <li>• Unlock <i>ADJ REF</i>. Set the parameter so that RX signal pitch matches sidetone.</li> </ul> <p><b>NOTE:</b> If the local oscillator appears to be missing or cannot be tuned, the synthesizer communications address may be incorrect. Refer to <i>MENU:OSC ID</i>.</p>
<p>ADJ RTC {RTC} +00 s/day</p>	<p>Can be used to improve accuracy of the built-in real-time clock.</p> <p><b>To adjust the RTC time-compensation value:</b></p> <ul style="list-style-type: none"> <li>• Set the clock to a known time standard using <i>MENU:ADJ TIME</i>.</li> <li>• After 1 to 3 days, check the RTC's error in seconds using <i>ADJ TIME</i>.</li> </ul>

	<ul style="list-style-type: none"> <li>Compensate by changing the <i>ADJ RTC</i> parameter by an equal but opposite amount, divided by days. <b>Example:</b> Clock set accurately on Monday at noon, then checked at noon on Wednesday (2 days); observed error of 8 seconds fast. To compensate, decrease the <i>ADJ RTC</i> setting by 4 seconds per day (8/2).</li> <li>Set the clock accurately and repeat the test.</li> </ul> <p>Also see <i>MENU:ADJ TIME</i> and <i>MENU:ADJ DATE</i>.</p>
ADJ SMTR {SMT} 100	<p>Used to set the S-meter's S9 level.</p> <p><b>To calibrate the S-meter:</b></p> <ul style="list-style-type: none"> <li>Put the KH1 into TX TEST mode to prevent possible damage to the signal generator due to accidental transmit. Use <b>XMTR</b> -&gt; <b>TST</b>.</li> <li>Bypass the ATU, if applicable, using <i>MENU:ATU MODE</i>.</li> <li>Band-pass filter tuning (<i>MENU:ADJ BPF</i>) and AGC voltage (<i>MENU:ADJ AGC V</i>) must be aligned first. Do this now if applicable.</li> <li>Select crystal filter 1 (<b>RCVR</b> -&gt; <b>FL1</b>). (MDS may vary slightly among filters.)</li> <li>Connect a signal generator to the KH1's BNC jack. Set the sig gen for the desired test frequency, at an amplitude of -73 dBm (S9), and turn it on.</li> <li>Unlock the ADJ SMTR menu entry. Both the parameter value and the current S-meter reading are shown, e.g. "100 -&gt; S9".</li> <li>Adjust the parameter until the LCD shows S9.</li> </ul>
ADJ SWR {SWR}	<p>Helps null the SWR bridge, ensuring SWR accuracy. This is especially important when the ATU is used. Adjustment is done using trimmer capacitor C80.</p> <p><b>To null the SWR bridge:</b></p> <ul style="list-style-type: none"> <li>Remove the KH1's top cover to provide access to C80.</li> <li>Locate a <b>non-metallic tuning tool</b> suitable for adjusting C80. An alternative is a jeweler's screwdriver wrapped in electrical tape or other insulating material.</li> <li>Connect a dummy load to the BNC jack and a paddle or key to the key jack.</li> <li>Make sure <i>MENU:KEY JACK</i> is <b>not</b> set to RS232.</li> <li>Set the whip band switch on the top panel to the center-OFF position (if applicable). This disconnects the whip toroid from the ATU, reducing stray reactance, and eliminates any RF burn hazard from the whip mounting bolt.</li> <li>Set <i>MENU:ATU MODE</i> to Bypass, if applicable.</li> <li>Unlock the <i>ADJ SWR</i> menu entry. Line 1 of the LCD will show "C80 -&gt; Null" as a reminder. Line 2 shows bridge detector voltage (0000 when not transmitting).</li> <li>Press the hand key or paddle (firmware treats paddles as hand keys while in this menu entry). This will put the radio into TX mode. Adjust C80 for best null.</li> <li>Exit the menu.</li> </ul>
ADJ TIME {TIM}	<p>Used to view/set the RTC's time registers. Time-keeping accuracy can be improved using <i>MENU:ADJ RTC</i>. (Also see <i>MENU:ADJ DATE</i>.)</p> <p><b>To set the time (24 hour format):</b></p> <ul style="list-style-type: none"> <li>Unlock the <i>ADJ TIME</i> menu entry.</li> <li>Tap <b>1</b> to exit, <b>2</b> to set hours, <b>3</b> to set minutes, <b>4</b> to set seconds.</li> </ul>
ADJ WMTR {WMT}	<p>Calibrates the KH1's power reading against a known-accurate external watt meter.</p> <p><b>To calibrate the watt meter:</b></p>

100	<ul style="list-style-type: none"> <li>• Connect a known-accurate wattmeter and 50 ohm dummy load to the BNC jack and a keyer paddle or hand key to the KEY/DATA jack.</li> <li>• Make sure <i>MENU:KEY JACK</i> is <b>not</b> set to RS232.</li> <li>• Set the whip band switch on the top panel to the center-OFF position (if applicable). This disconnects the whip toroid from the ATU, reducing stray reactance, and eliminates any RF burn hazard from the whip mounting bolt.</li> <li>• Set <i>MENU:ATU MODE</i> to Bypass, if applicable.</li> <li>• Locate the <i>ADJ WMTR</i> menu entry and unlock it.</li> <li>• Press the hand key or paddle (firmware configures the jack as a hand key on both the dot and dash inputs). This will put the radio into transmit mode.</li> <li>• Adjust the parameter until the KH1 reading matches the external watt meter.</li> </ul>
ATU MODE {ATM} Not Inst	<p>If an ATU is installed, set this parameter to Bypass or Auto. When set to Auto, an ATU icon will appear in line 2 of the operating display. If the parameter is set to anything besides Not Inst., the KH1 will test the ATU module on power-up.</p> <p><b>To use ATU MODE test settings:</b></p> <ul style="list-style-type: none"> <li>• The K1 - K8 Test settings activate individual latching relays. Firmware treats paddles as hand keys while in these test modes so SWR can be easily checked. This is useful for verifying the L and C components on the ATU.</li> <li>• The GP0 - GP7 Test settings also activate K1 - K8. But instead of returning to nominal voltage after activating a latching relay, they hold the associated driver output at 5 V.</li> <li>• The COM setting doesn't activate relays; it places 5 V on the common line.</li> </ul>
ATU PARAM {ATP}	<p>This menu entry can be used to view and change the ATU's L, C, and Z (network high/low impedance) settings. It overrides the Bypass or Auto setting of the <i>ATU MODE</i> menu entry until the next time that setting is changed.</p> <p><b>The primary purpose for this feature is to manually peak up signals with the ATU's L-network when using the KH1's SWL band.</b> Other uses include: (1) checking the ATU's tuning solution for a given load (L is shown in <math>\mu\text{H}</math> and C in pF); (2) peak up receive sensitivity on any band without transmitting; (3) manually try settings different from what the ATU arrived at. (In the latter case, note that the ATU tries 100% of network combinations and selects the one that produces the lowest SWR. Manual adjustment is not likely to produce better results.)</p> <p><b>To view or change ATU network values:</b></p> <ul style="list-style-type: none"> <li>• Unlock the <i>ATU PARAM</i> menu entry.</li> <li>• Tap switch <b>1</b> to exit, <b>2</b> to view/set L, <b>3</b> to view/set C, and <b>4</b> to view/set [Z].</li> <li>• If you make any changes, they will persist after menu exit.</li> <li>• To return to normal ATU operation, use the <i>ATU MODE</i> menu entry to re-engage the desired mode. This is necessary even if the desired mode is already in effect. For example if mode is already Auto, go to Bypass, then back to Auto.</li> </ul>
DISP MODE {DSP} Operate	<p>Selects one of two display modes for line 2 of the LCD:</p> <ul style="list-style-type: none"> <li>• <b>Operate</b> mode shows the S-meter reading, along with icons for the attenuator and ATU (when applicable), battery status icon, and 24-hour time.</li> </ul>

	<ul style="list-style-type: none"> <li>• <b>V/I/Temp</b> mode shows the supply voltage (internal battery or external supply, whichever is higher), current drain, and PA temperature (deg. C). These values are updated continuously in both RX and TX modes.</li> </ul> <p>Many operators assign the <i>DISP MODE</i> menu entry to a PFn function (for an example of how to do this, see <i>MENU:PF1 FUNC</i>).</p> <p><b>NOTE:</b> The <i>VBAT</i> menu entry provides a more accurate indication of internal battery voltage. It remains accurate even if an external supply is plugged in to provide charging voltage, so it can be used to estimate remaining charge time. <i>VBAT</i> also shows approximate ampere-hours of energy consumed since the AH parameter was last reset to 0. (See <i>MENU:VBAT</i> for details).</p>
EE INIT {EE}	<p><b>CAUTION: This menu entry can be used to reinitialize <u>ALL</u> of the KH1’s stored parameters, or just the <u>OPERATIONAL</u> parameters.</b></p> <p><b>If a full EE INIT is done, factory calibration settings will be lost, so a full recalibration will be necessary. To avoid this, try an <u>OPERATIONAL</u> EE INIT first.</b></p> <p><b>EE INIT procedure:</b></p> <ul style="list-style-type: none"> <li>• Unlock the <i>EE INIT</i> menu entry. <u>This is a safe operation</u> that does not start init.</li> <li>• Set the parameter to OPERATIONAL or FULL. <u>This is also safe</u>, since EEPROM initialization does not take place until power is turned OFF and back ON. To cancel any pending init, set the parameter back to Disabled, then exit the menu.</li> <li>• To proceed with EE INIT, turn the KH1 OFF; wait a few seconds; turn it back ON.</li> <li>• When you see the message “INIT REQUIRED,” tap any switch. The selected EEPROM parameter initialization type will then occur.</li> <li>• If you unintentionally reset all parameters, contact Elecraft support.</li> </ul>
FIRMWARE {F/W}	Shows the firmware revision, e.g. 1.00. There will also be a note about the revision <i>type</i> to the right of the rev. number: “FT” = field test, “BETA” = beta test, and “PROD” = production release.
KEY IAMB {IAM} MODE A	Selects the Iambic keying mode (A or B). The default (mode A) is a little more forgiving for first-time operators. Mode B may be preferred by operators who learned to do “squeeze-keying” with a keyer having a similar mode. Both provide dot- and dash-memories, but with slightly different “element-insert” timing.
KEY JACK {PDL} Pdl Norm	Selects paddle normal (used by most right-handed operators), paddle reverse (used by most left-handed operators), hand key, or RS232 interface. The latter is used for firmware updates, via a KXUSB cable and <i>KH1 Utility</i> software application. <b>NOTE:</b> The RS232 port also enables full remote control of the KH1. <b>The KEY jack is not available for keying in this case, though keying can be accomplished using a remote control command.</b> Refer to the <i>KH1 Programmer’s Reference</i> .
KEY WGHT {WGT} 1.25	Used to vary CW keying weight. The default setting provides roughly a 1:1 dot:space ratio, and is generally recommend.

<p>LOGGING {LOG} OFF</p>	<p>When <i>LOGGING</i> is ON, the KH1 will record up to 32K of transmitted CW text. Time/date/band/mode are also captured for use in extracting QSO data. The built-in keyer must be used to allow firmware to decode the user's transmitted CW.</p> <p><b>To configure and use CW text logging:</b></p> <ul style="list-style-type: none"> <li>• To enable logging, set the parameter to ON. TX text decode will then be turned on, and the MODE icon will flash off every few seconds as a reminder. If the log is filled, LOG FULL will be displayed until you tap any switch.</li> <li>• Make sure <i>MENU:ADJ DATE</i> and <i>MENU:ADJ TIME</i> have been set up.</li> <li>• To erase all log data, set the parameter to ERASE, then exit the menu.</li> <li>• To scroll through logged text, set the parameter to VIEW. The LCD will then show time/date stamps, band, and mode on line 1, and text on line 2. Use the VFO knob to scroll through text. Tap/hold the VFO knob to change scroll rate.</li> <li>• To “dump” the log as text, send “LG;” to the KH1 using <i>KH1 Utility's</i> Command Tester screen. The text can then be manually processed or copied/pasted into a third-party application for automatic extraction (not provided by Elecraft).</li> </ul>
<p>MSG RPT {RPT} 5 sec</p>	<p>Sets the message repeat interval. To repeat a message, <i>hold</i> a message button (1 – 3) rather than <i>tap</i>. A 5 - 10 sec. interval is about right for casual CQing. Shorter intervals may be needed during contests, and longer for periodic CW beacons.</p>
<p>PAN MODE {PAN} Off</p>	<p>Turns the scan/mini-pan function on or off. See pg. 18.</p>
<p>PAN SPAN {SPN} 10 kHz</p>	<p>Sets the total frequency range for the scan/mini-pan function. See pg. 18.</p>
<p>PAN THR {THR} -00</p>	<p>Sets the detection threshold for CW text decode and the scan/mini-pan function.</p> <p><b>To adjust the threshold for maximum sensitivity (recommended):</b></p> <ul style="list-style-type: none"> <li>• Disconnect the antenna.</li> <li>• Adjust the PAN THR parameter upward until “AFCMP” switches from 0 to 1.</li> </ul> <p>NOTE: Any other setting will result in a higher threshold, which may be useful in high-QRM situations.</p>
<p>PFn FUNC {PFn} PFn Unset</p>	<p>Configures the KH1's user-programmable functions as shortcuts to any menu entry.</p> <p><b>Programmable function setup and use:</b></p> <ul style="list-style-type: none"> <li>• Locate the menu entry for the target PFn function (e.g. <i>PF1 FUNC</i>).</li> <li>• Rotate VFO A to select the desired menu entry (e.g. <i>ATU MODE</i>).</li> <li>• This will change the function's text to a 3-letter abbreviation that serves as a reminder of the assignment (in this case, ATM).</li> <li>• Exit the menu. The target PFn function (in this case, <b>PFn/XMTR</b> -&gt; <b>ATM</b>) will now jump to the specified menu entry (<i>ATU MODE</i>).</li> <li>• If a menu entry is “binary” (2-valued), accessing it via a PFn function will change the value, display it, then return to normal display. In a few cases this</li> </ul>

	<p>applies to menu entries with more than two values. For example, if ATU MODE is set to Bypass or Auto, it will act like a 2-valued menu entry for PFn purposes.</p> <ul style="list-style-type: none"> <li>To clear a PFn assignment, set the PFn FUNC parameter to the value <b>PFn Unset</b> by scrolling the parameter to the name of the PFn FUNC entry itself.</li> </ul>
RIT CLEAR {CLR}	This menu entry can only be used as a PFn assignment. That function, when accessed, will clear any RIT/XIT offset.
SERIAL NR {S/N}	This menu entry can be used to view, but not change, the serial number of this KH1.
SW TONES {SWT} OFF	When set to ON, the KH1 will emit switch-event acknowledgement tones.
TEXT DEC {TXT} OFF	When set to ON, the KH1 will decode and display decoded CW text. See pg. 20.
VBAT {VBT}	<p>This menu entry shows two useful measurements:</p> <ul style="list-style-type: none"> <li>LCD line 1: internal battery voltage (assuming a KHIBC1 module is installed).</li> <li>LCD line 2: approximate Ah of energy consumed since the AH parameter was last reset to 0.</li> </ul> <p><b>To reset Ah to 0, hold the  switch. Also see pg. 21.</b></p> <p>NOTE: The voltage shown here is a more accurate reading of the internal battery than the “V/I/Temp” display (<i>MENU:DISP MODE</i>). For example, if the internal battery voltage is 12.0 V, it will read about 11.8 V using the V/I/Temp display, due to an internal supply/battery “wire-ORing” diode. But it will read 12.0 V in the VBAT menu entry, since this measurement occurs on the battery side of the diode. The VBAT voltage reading also remains accurate when an external power supply is plugged in for charging. For further details, see pg. 21.</p>
VFO FAST {FST} 100 Hz	<p>Specifies the VFO step size that’s in effect when the frequency display shows only one decimal place. (When two decimal places are displayed, the tuning rate is 10 Hz; when none are displayed, the rate is 1 kHz.)</p> <p>Since the VFO knob has a small diameter, a VFO FAST setting of 200 Hz (or even higher) may be a pragmatic choice even for CW operation.</p>

# TROUBLESHOOTING

## GENERAL

- **UTILITY? shown on LCD:** Do a forced firmware load (pg. 22).
- **ERR (error) message displayed:** Refer to **ERROR MESSAGES** (pg. 33).
- **BAT LOW flashes:** Check the battery voltage (see *MENU:DISP MODE* and *MENU:VBAT*).
- **Can't turn power on:** Check power cable, or make sure a battery pack is plugged in and charged.
- **KXUSB cable keys TX:** *MENU:KEY JACK* must be set to RS232 when this cable is plugged in.
- **VFO frequency or other parameters not saved on power-down:** The KH1 only updates changed settings when a switch is pressed – not continuously, and not automatically on power-down.
- **General problem with transmit and/or receive:** Many problems can be caused by low power supply voltage or by a noisy or intermittent supply. Check your power supply's on/off switch, voltage, fuses (if applicable), and DC cabling. The KH1 provides voltage and current monitoring (see *MENU:DISP MODE*). Also see TRANSMIT and RECEIVE troubleshooting sections, below.
- **General problem with firmware behavior:** (1) Check all menu settings (see previous section). (2) Try loading the latest KH1 firmware. Review release notes.
- **Not Applicable message:** The function in use doesn't apply in the present context.
- **Not Implemented message:** The function you're trying to use has not yet been implemented.
- **Mode icon flashes slowly:** This is a reminder that logging is enabled.
- **VFO frequency doesn't change:** The VFO may be locked. Use **BAND/MODE** -> **4** to unlock.

## TRANSMIT

- **Keyer paddle not secure:** If the paddle wobbles or adds extra elements when keying, it is probably not fully plugged into the KEY jack. Be sure to push it all the way into the jack until you feel a snap. Note that there are two small plastic nubs to the left and right of the jack: the paddle's PC board should rest on these when properly positioned, preventing it from rotating.
- **Whip mounting post slightly loose:** This is normal. See explanation at top of pg. 10.
- **Can't transmit:** (1) Make sure the key or keyer paddle is plugged in. (2) Make sure *MENU:KEY JACK* is not set to RS232. (3) Turn off TX TEST mode if applicable (**PFn/XMTR** -> **TST**).
- **Low power output:** Check battery voltage. You may also be working into a high-SWR load and/or using a low supply voltage. The KH1 does not use ALC to maintain constant power output, so high SWR may result in reduced power. **Note:** Max power also varies per band.
- **BND END warning:** Indicates an attempt to transmit outside the ham bands.
- **HI CUR or HI SWR warning:** Check supply voltage. If voltage is low and/or a low-impedance antenna load is present, current can go up for a given requested power level. Reduce power if necessary. (The KH1 may do this automatically. If this doesn't reduce the current or reflected power to safe levels, the KH1 will drop out of transmit mode.)
- **HI TEMP warning:** PA heat sink temperature has exceeded the safe operating limit. Set display line 2 mode to V/I/Temp using *MENU:DISP MODE*. The normal display will then show power supply voltage, current drain, and PA temperature. Allow heat sink to cool. Reduce power if necessary. (The KH1 may reduce power, drop out of transmit mode, or turn itself off.)
- **Top cover is hot to the touch:** The top cover sheet metal provides part of the KH1's PA heat sinking, so it is normal for it to feel quite warm during long transmissions. The panel will run cooler if you use shorter transmissions, lower power, or a lower supply voltage.



## RECEIVE

- **Internal speaker clipping / distortion:** The KH1's small internal speaker is not intended for use in high-noise environments, such as in a noisy vehicle or outdoors in high winds. If audible artifacts occur, reduce AF gain or switch to headphones (or use an external powered speaker).
- **No received signal, or signal too low:** Check all of the following: (1) antenna connectors; (2) attenuator setting; (3) AF gain setting; (4) whip slide switch setting (may be in center-off position); (5) headphone plug.
- **Opposite-sideband images heard:** Some received opposite-sideband (OSB) signal will always be heard on strong signals with a 4-crystal filter. The amount varies with filter bandwidth; suppression will be best with setting FL1. With strong signals, AGC reduces their audio level when tuned in, but not when tuned to the OSB image, reducing apparent OSB suppression.
- **Mobile installation noise:** If the 12 V DC accessory jack in a vehicle causes interference to the KH1's receiver: (1) improve vehicle's DC filtering; (2) use a battery; (3) relocate the antenna.
- **HI RFI warning:** The KH1 protects itself from high signal levels. First the -10 dB attenuator is inserted (if attenuation was set to 0 dB). The second step, if necessary, is to insert the -30 dB attenuator. Once signals return to a safe level for 5 seconds, the attenuator will be turned off.

## ERROR MESSAGES

If you see an error message, try the steps provided in the table below, in order, to correct the problem. If the error persists, contact Elecraft support. **DO NOT ATTEMPT TO REPAIR SURFACE-MOUNT COMPONENTS** unless you have the required experience and proper equipment.

ERROR MESSAGE	DESCRIPTION	TROUBLESHOOTING STEPS
<b>EE SAVE ERROR</b>	During an internal MCU EEPROM save operation, an I2C bus operation failed.	Check the MCU IC for shorts, unsoldered pins, incorrect voltages, etc. Re-program the MCU, then do an EE INIT (see <i>MENU:EE INIT</i> ). Replace the MCU.
<b>ERR: ATU1</b>	An ATU module is declared to be installed, but the module's MCP23008 I/O expander write/read test failed.	If there's no ATU module installed, set its menu entry to "Not Inst." Check for misalignment of the ATU module's 6-pin connector. Inspect the ATU PCB for shorts, unsoldered pins, etc. Do signal checks on the I2C bus between the main PCB and ATU PCB.
<b>ERR: DAC</b>	The 4-channel D/A converter failed a control register write/read test.	Inspect the DAC IC for shorts, unsoldered pins, etc. Do signal checks on the I2C lines between the main PCB and DAC. Also check voltages, etc. Replace the DAC IC.
<b>ERR: EEPOT</b>	The AGC threshold-setting EEPOT failed a write/read test.	Inspect the EEPOT IC for shorts, unsoldered pins, etc. Do signal checks on the I2C bus between the main PCB and EEPOT. Also check voltages, etc. Replace the EEPOT IC.
<b>ERR: EXT EEPROM1</b>	The external 32K EEPROM I2C write command failed.	Inspect the 32K EEPROM IC for shorts, unsoldered pins, etc. Do signal checks on the I2C bus between the main PCB and the EEPROM. Also check voltages, etc. Replace the 32K EEPROM IC.

<b>ERR: EXT EEPROM2</b>	The external 32K EEPROM read test returned the wrong values.	Inspect the 32K EEPROM IC for shorts, unsoldered pins, etc. Do signal checks on the I2C bus between the main PCB and the EEPROM. Also check voltages, etc. Replace the 32K EEPROM IC.
<b>ERR: MCU EEPROM1</b>	The PIC18's on-chip EEPROM failed a write/read test with value 0x55.	Reprogram the MCU. Check the MCU IC for shorts, unsoldered pins, etc. Replace the MCU.
<b>ERR: MCU EEPROM2</b>	The PIC18's on-chip EEPROM failed a write/read test with value 0xAA.	Reprogram the MCU. Check the MCU IC for shorts, unsoldered pins, etc. Replace the MCU.
<b>ERR: PA TEMP</b>	The LM20 PA temperature measurement IC's output voltage is out of the expected range.	Inspect the LM20 IC for shorts, unsoldered pins, etc. Do signal checks on the analog signal line between the main PCB and LM20. Replace the LM20 IC.
<b>INIT REQUIRED</b>	On-chip EEPROM is erased or has an incorrect format ID.	Tap any switch. An EEPROM parameter initialization will occur. Also see <i>MENU:EE INIT</i> .
<b>Stuck Paddle?</b>	Firmware has detected that a keying device has asserted either the dot or dash input to the KEY/DATA jack.	If a KHPD1 or other keyer paddle is plugged in, unplug it and turn power OFF, then ON to verify that this was the cause of the warning message. Check the attached KHPD1 or other keying device for shorts. Adjust contact spacing. (The hex wrench for the KHPD1 is stored inside the transceiver.) Turn power OFF, open the rear panel, and look for the hex wrench near the rear panel thumb latch. If applicable, unplug the KXUSB cable from the KEY/DATA jack. Make sure that <i>MENU:KEY JACK</i> is not set to "RS232".
<b>Unplug KXUSB Cbl</b>	The user did a firmware update using KH1 Utility, which requires that a KXUSB cable be plugged into the KEY/DATA jack. Firmware then recommends disconnecting this cable so the jack can be used as a key or paddle input.	Disconnect the KXUSB cable. Make sure that <i>MENU:KEY JACK</i> is not set to "RS232".
<b>UTILITY?</b>	Either the KH1 firmware checksum failed or a forced firmware load was requested by the user (by holding down switch <b>2</b> during power-on).	Connect a KXUSB cable to the KH1 and to a computer. Load firmware using <i>KH1 Utility</i> . This program will recognize that the KH1 is in its "boot loader" and will send new firmware. Also see UPDATING FIRMWARE, pg. 22.

# THEORY OF OPERATION

## Receiver

The KH1's receiver uses a low-current superhet architecture with a 9.215 MHz I.F. This frequency provides a good balance between crystal filter performance and image rejection. The mixer's noise figure is low enough to preclude the use of an RF preamp. A two-stage RF attenuator is provided for strong-signal situations.

Local oscillator signals for both the LO and BFO are synthesized by a specialized IC that generates signals in the GHz range, then divides them down to HF. This provides both fine resolution and low phase noise. High-side mixer injection (above the low-pass filter cutoff) is used on all five bands (40-15 m), again for the purpose of improving image rejection.

Audio-derived AGC is developed out of the AF preamp stage, then DC-amplified by a darlington transistor. The resulting voltage is applied to pin 1 of both the mixer and product detector, resulting in a very usable AGC range.

The class-AB final audio amp stage uses analog electronic gain control so it can be adjusted by the MCU. The gain control voltage is generated by a DAC (D-to-A converter) channel. The amp can drive the small speaker to about 0.5 W peak.

## Transmitter

The same IC that generates receive LO and BFO also generates the TX carrier frequency during transmit. This is amplified by an NPN driver stage, then fed to a VHF MOSFET TO-220 package transistor biased class AB to ensure good gain and power output from 7 to 15 MHz.

Power output is controlled by driver bias. The driver's keying output wave shape is generated by a PNP high-side integrator to prevent key clicks.

Low-pass filter and ATU relays are latching to reduce total current drain.

## Control circuits and signal processing

All transceiver control functions are controlled by a PIC18 microcontroller. The MCU also handles signal some processing functions: (1) sidetone generation; (2) CW text decode; (3) spectral analysis to drive the mini-pan display; (4) audio signal detection and averaging, for the S-meter and other purposes.

TR switching is handled by a MOSFET switch.

Supplemental circuits include voltage, current and temperature monitoring; a 32 K EEPROM for decoded TX text logging; and a real-time clock IC (RTC).

# SPECIFICATIONS

**NOTE:** Specifications apply only within ham bands. All measurements taken with 11.0 VDC supply.

## GENERAL

Frequency Range	<b>Receive, amateur bands:</b> 7.0-7.5 MHz, 10.0-10.5 MHz, 14.0-14.5 MHz, 18.0-18.5 MHz, and 21.0-21.5 MHz <b>Receive, general coverage (SWL band):</b> 6.7-22.0 MHz. ( <b>Note:</b> Receive I.F. is 9.215 MHz. Reception near I.F. subject to lower image rejection.) <b>Transmit:</b> 40/30/20/17/15 meter amateur bands. Transmit excluded in some ranges (by country).
Frequency Stability	+/- 1 ppm typical at 25 C after 5-minute warm-up
Antenna Inputs	<b>BNC jack:</b> 50 ohms, nominal <b>Whip:</b> 45" (114 cm.); matching network covers 20/17/15 m with ATU CW, and CW/SSB cross-mode (CW TX, SSB RX).
Modes	
Supply Voltage and Current	8 V min, 15 V max. .5 to 1.0 A typical in transmit; 40 – 80 mA typical in receive (no signal). Internal battery charging (KHIBC1), when active, adds ~250 mA. Charger plugged in but not charging: 3 mA (disconnect charger when not needed).
Size and Weight	Size of basic KH1, including knobs and connectors: 5.7" x 2.3" x 1.2" (14.5 x 5.8 x 3.0 cm). Weight: ~6 oz (0.17 kg). With all options and battery: ~13 oz (0.36 kg).

## RECEIVER

Sensitivity (MDS)	-133 dBm (typ.) @14.0 MHz, 500 Hz bandwidth
S-Meter Calibration	6 dB per unit from S0-S9; 10 dB per unit above
Audio Output	Internal speaker, ~0.5 W peak
Receive Features	Scan/mini-pan; 3 crystal filter bandwidths (~0.3, 0.5, 2.0 kHz); RIT; filter center pitch tracks sidetone pitch; built-in text decode for CW mode.

## TRANSMITTER

Output Power	~5 W. ( <b>Note:</b> Maximum available output power varies with power supply voltage, antenna load impedance, and PA temperature.)
Transmit Features	Full CW break-in; MOSFET T/R Switching; 3 DATA/CW messages; automatic logging of DATA/CW text (see <i>MENU:LOGGING</i> ).
Spurious Emissions	> 50 dB below carrier typ. @ 5 W
CW Sidetone Pitch	500-800 Hz (receive filter center frequency tracks sidetone pitch)

# CUSTOMER SERVICE AND SUPPORT

## TECHNICAL ASSISTANCE

Technical assistance is available to all of our customers. We encourage you to use e-mail for faster response to your questions. E-mail address is: [support@elecraft.com](mailto:support@elecraft.com). If you need replacement parts, send an e-mail to [parts@elecraft.com](mailto:parts@elecraft.com). We typically respond to e-mail the same day from Monday through Friday. Telephone assistance is available from 9 A.M. to 5 P.M. Pacific time (weekdays only) at 831-763-4211. (For faster response, please use e-mail rather than call.)

## REPAIR / ALIGNMENT SERVICE

If necessary, you may return your Elecraft product to us for repair, calibration or alignment. If you purchased your Elecraft product from one of our Authorized Distributors, please contact them first. They can perform all of the factory calibrations that can be made at the factory.

## IMPORTANT:

- REMOVE BATTERY PACK before shipping (see instructions on pg. 6).
- You must contact Elecraft before mailing your product to obtain Return Authorization to begin the return process. When e-mailing, please provide your call sign, the product in question, and a description of what the problem is. We will reply with an e-mail that contains shipping instructions, and current information on repair fees and turn-around times. Our repair location may be different from our factory location. We will give you the address to ship your KH1 to at the time of repair authorization. Packages shipped to Watsonville, CA without authorization will incur an additional shipping charge for reshipment to the required repair depot.

## Elecraft 1-Year Limited Warranty

This warranty is effective as of the date of first consumer purchase (or if shipped from the factory, the date the product is shipped to the customer). It covers both our kits and fully assembled products. For kits, before requesting warranty service, you should fully complete the assembly, carefully following all instructions in the manual.

**Who is covered:** This warranty covers the original owner of the Elecraft product as disclosed to Elecraft at the time of order. Elecraft products transferred by the purchaser to a third party, either by sale, gift, or other method, who is not disclosed to Elecraft at the time of original order, are not covered by this warranty. If the Elecraft product is being bought indirectly for a third party, the third party's name and address must be provided at time of order to ensure warranty coverage.

**What is covered:** During the first year after date of purchase, Elecraft will replace defective or missing parts free of charge (post-paid). We will also correct any malfunction to kits or assembled units caused by defective parts and materials. Purchaser pays inbound shipping to us for warranty repair; we pay shipping to return the repaired equipment to you by UPS ground service or equivalent to the continental USA and Canada. For Alaska, Hawaii, and other destinations outside the U.S. and Canada, actual return shipping cost is paid by the owner.

**What is not covered:** This warranty does not cover correction of kit assembly errors. It also does not cover misalignment; repair of damage caused by misuse, negligence, battery leakage or corrosion, or builder modifications; or any performance malfunctions involving non-Elecraft accessory equipment. The use of acid-core solder, water-soluble flux solder, or any corrosive or conductive flux or solvent will void this warranty in its entirety. Also not covered is reimbursement for loss of use, inconvenience, customer assembly or alignment time, or cost of unauthorized service.

**Limitation of incidental or consequential damages:** This warranty does not extend to non-Elecraft equipment or components used in conjunction with our products. Any such repair or replacement is the responsibility of the customer. Elecraft will not be liable for any special, indirect, incidental or consequential damages, including but not limited to any loss of business or profit



# ELECRAFT KH1 PROGRAMMER'S REFERENCE

Rev. A, Oct. 20, 2023

## TABLE OF CONTENTS

OVERVIEW .....	2
COMPUTER INTERFACE .....	2
COMMAND TYPES .....	2
COMMAND LIST .....	3
AG (AF Gain; SET only).....	3
DS (Display Text; GET/SET) .....	3
EN (Encoder Emulation; SET only).....	3
FA (VFO Frequency; SET only) .....	3
H (Help; GET only) .....	3
HK (Hand-Key Emulation; SET only) .....	3
I (ID; GET only).....	3
LD (Firmware Load; SET only).....	3
MD (Operating Mode; SET only) .....	4
MN (Menu Open by Name; SET only) .....	4
RV (Firmware Revision; GET only) .....	5
SN (Serial Number; GET only).....	5
SW (Switch Emulation; SET only).....	5
CHANGE HISTORY .....	5

## OVERVIEW

The KH1 supports 100% remote control. This feature is primarily intended for updating firmware and for automated factory testing (see the Elecraft KH1 Alignment Manual for manual procedures). That said, it could also be used to operate the radio using custom software, in applications ranging from “HF-Pack Lite” to putting the KH1 at an antenna feedpoint.

KH1 commands consist of one or two letters followed by zero or more parameters. There is some overlap with the command sets from other Elecraft transceivers. But in general the KH1 command set is more limited.

## COMPUTER INTERFACE

The KH1 can be controlled through the KEY/DATA jack using a KXUSB cable and a terminal emulator or software application. *MENU:KEY JACK* must be set to RS232. The serial interface baud rate is 9600b (fixed).

When the KEY/DATA jack is being used for remote control, it is not available for use with a keyer paddle or hand key. However, there's a host command (HK) that can be used to simulate CW keying, as if using a hand key. This is used during manual or factory alignment procedures, but it could be used for CW transmission, replacing the key or keyer paddle. The software application would be responsible for ASCII to CW translation and/or could provide a keying input device.

## COMMAND TYPES

There are three categories of KH1 remote-control commands: UI emulation, ID/firmware load, and parametric. There's also a "help" command that lists available commands in terse form (H).

**EMULATION:** The EN (encoder), DS (display), HK (hand key), MN (menu), and SW (switch) commands emulate the UI, in a manner that is completely context-dependent, like the panel controls themselves. These commands can be used to access menu entries or emulate radio operation, in most cases providing a way to extend the radio's remote control capabilities in lieu of other specific parametric commands.

Examples: A GET of the filter number could be created using SW1H; (bring up RCVR functions) followed by DS1; (read line 1 of the display). A SET of filter number 2 could be effected by then sending SWT2;.

**ID/FIRMWARE LOAD:** This group includes I (rig ID), LD (firmware load), RV (firmware rev.), and SN (serial number). "I;" returns "KH1;" in the main app (upper case), while the boot loader responds to "I" with "kh1" (lower case). This allows KH1 Utility to tell whether it's talking to the boot loader or the main app. "RV;" returns "RVnn.nn;" (firmware revision). "LD;" initiates firmware loading and is only used by KH1 utility. SN can be used by anyone to get the serial number. It is used by the factory to set the serial number, which requires a non-public password.

**PARAMETRIC:** Commands such as AG (AF gain), MD (mode), and FA (frequency), behave like similar commands on the KX2, KX3, etc. In most cases only SETs are provided, since the KH1 doesn't have “AI” capability (auto-info) and is not intended to support apps like HRD, etc. If required, a GET can be simulated by using a display read command (DS command). For example the operating frequency could be obtained by reading line 1 of the LCD.



# COMMAND LIST

All commands and responses are terminated by a semicolon.

## AG (AF Gain; SET only)

FORMAT: AGnn; where <nn> is 00-30

NOTE1: The AF gain value is stored separately for phones and speaker.

NOTE2: AF gain can be incremented/decremented using the ENAU/ENAD commands.

## DS (Display Text; GET/SET)

FORMAT: DSls; where:

<l> = '1' (line 1, or upper row) or '2' (line 2, or lower row)

<s> = Up to 16-char string (string is returned for GET, and supplied for SET)

NOTE1: The DS SET string is flashed for about 1.5 seconds. Use subsequent DS SETs to keep the flashed string on the display longer.

NOTE2: The LCD supports 8 special characters, some of which change depending on the radio's operational context. For a GET, the host app must translate these to suitable characters within the host's display environment. For a SET, the host app must embed low-hex ASCII values for special characters that make sense in the KH1's context. List of characters and contexts TBD.

## EN (Encoder Emulation; SET only)

FORMAT: ENed; where:

<e> = encoder: 'A' (AF gain) or 'V' (VFO)

<d> = direction: 'U' (up/clockwise) or 'D' (down/counter-clockwise)

## FA (VFO Frequency; SET only)

FORMAT: FAf; where <f> is in 10 Hz units (e.g. 1400000 = 14000.00 kHz)

## H (Help; GET only)

FORMAT: H; Responds with terse help information.

## HK (Hand-Key Emulation; SET only)

FORMAT: HKm; where m == 1 for key-down, and 0 for key-up.

## I (ID; GET only)

FORMAT: I; Responds with "KH1;"

NOTE: If the radio is in the boot loader, it responds to "I" with "kh1".

## LD (Firmware Load; SET only)

FORMAT: LD; Jumps to boot loader.

## MD (Operating Mode; SET only)

FORMAT: MDn; where n = 0 (CW), 1 (LSB), 2 (USB), 4 (RTTY).

NOTE: In SSB modes, the KH1 operates cross-mode (CW transmit, SSB receive). SSB receiving operators hear the KH1's CW at a 700 Hz pitch.

## MN (Menu Open by Name; SET only)

FORMAT: MNsss; where <sss> is a short-form menu ID string. See list below. The target menu entry is unlocked if applicable. The menu can be exited by emulating a tap of the [x] field for the given menu entry. In most cases this is switch 4, so: "SW4T;".

NOTE 1: These 3-character ID strings are also used to identify programmable switch functions in the associated PFn display fields.

NOTE 2: Some menu parameters can be changed using the **MP** command (see below).

### ID      MENU ENTRY

AGC	ADJ AGC V	
BFO	ADJ BFO	
BIA	ADJ BIAS	
BPF	ADJ BPF	MP command applies
DAT	ADJ DATE	
OSC	ADJ OSCID	
PWR	ADJ PWR	MP command applies
REF	ADJ REF	
RTC	ADJ RTC	
SMT	ADJ SMTR	
SWR	ADJ SWR	
TIM	ADJ TIME	
WTM	ADJ WMTR	
ATM	ATU MODE	
ATP	ATU PARAM	
DSP	DISP MODE	
EE	EE INIT	
F/W	FIRMWARE	
IAM	KEY IAMB	
PDL	KEY JACK	
WGT	KEY WGHT	
LOG	LOGGING	
RPT	MSG RPT	
PAN	PAN MODE	
SPN	PAN SPAN	
THR	PAN THR	
PF1	PF1 FUNC	
PF2	PF2 FUNC	
PF3	PF3 FUNC	

CLR	RIT CLEAR
S/N	SERIAL NR
SWT	SW TONES
TXT	TEXT DEC
VBT	VBAT
FST	VFO FAST

### **MP (Menu Parameter; GET/SET)**

FORMAT: MPnnn; where <nnn> is a decimal value from 0-999.

This command must be preceded by an MN command that opens an applicable entry (and unlocks it if required). These menu entries include ADJ BPF and ADJ PWR.

### **RV (Firmware Revision; GET only)**

FORMAT: RV; Response format: "RVxx.xx;"

### **SN (Serial Number; GET only)**

FORMAT: SN; Response format: "SNnnnnn;"

### **SW (Switch Emulation; SET only)**

FORMAT: SWnt; where:

<n> = '1'-'4' (regular pushbutton switches) or '5'-'6' (encoder switches)

<t> = 'T' (tap) or 'H' (hold)

## **CHANGE HISTORY**

Rev. A, Oct. 9, 2023: Added **MP** command.