

ILER-40 QRP SSB Transceiver for 40m band

(Retranslated by Slim Haines G4IPZ)

HOW IT WORKS

www.qsl.net/ea3gcy

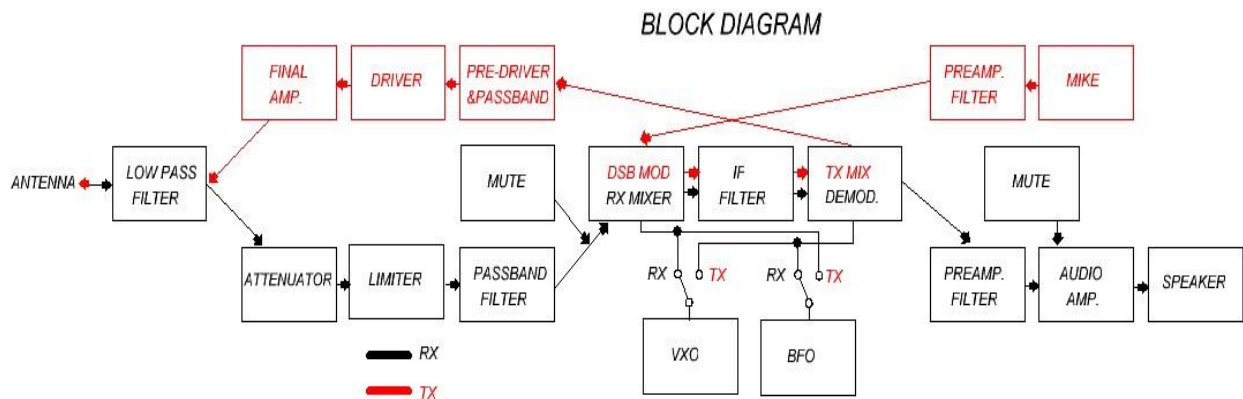

The circuit

We will trace the receive and transmit signals and operation through the ILER 40 circuitry. The block diagram will help you understand the overall functioning of the equipment, the path of the RX signal is drawn in black and TX signal in red.

Local oscillator (crystal VXO).

The LO (Local Oscillator) generates a variable frequency signal by adjusting the tuning via CV2 or CV3 (see full text). In receive mode, the signal goes to the RX mixer IC2 via relay RL1a, where it mixes with the signal from the antenna to get the IF frequency.

In transmit mode the signal is sent to transmission mixer IC3 and mixed with the IF signal to create the modulated double side band signal for transmission.

In the ILER-40, a VXO (variable crystal oscillator) is used as the LO since that can generate a frequency range of around 11,920 MHz to 12.020MHz (approximately) using a pair of 12.031MHz crystals. Alternatively it can generate a frequency between 11.985MHz and 12.085MHz (approximately) using a pair of 12.096MHz crystals

Thus for example, in transmission, a VXO signal at 12.015Mhz when mixed with the 4.915Mhz IF frequency gives a difference signal at 7.100Mhz.

In receive mode the 12.015MHz LO signal is mixed with antenna input at 7.100Mhz and also by choosing the difference signal of the mixing, we obtain the required 4.915MHz IF signal.

The VXO oscillator/buffer is formed by transistors Q3 and Q4 where Q3 forms a "Colpitts" style oscillator. Two parallel crystals makes it possible to obtain up to a 20% greater frequency deviation than a single crystal. The inductance L6 allows the crystal frequency to be varied a few tens of kHz via one of the two variable tuning capacitors CV2 and CV3. Transistor Q4 is a buffer amplifier from which the signal is routed via RL1a to the oscillator input (pin 6) of IC2 (RX) or IC3 (TX) depending on the RX/TX mode.

BFO Beat Frequency Oscillator

The BFO (beat oscillator) produces the beat signal to generate the IF frequency for both DSB modulated (double sideband) signal for transmission, and to demodulate the receive IF SSB (single sideband) signal and convert it into audio.

Like the VXO, the BFO oscillator type is a classic "Colpitts" formed by the crystal X5 and the transistor Q2. The signal is switched through to the inputs of RL1b OSC1 (pin 6) of IC2 during TX or IC3 (pin 6) in the case of RX. You will note that this is the reversed situation to the connections for the VXO LO.

Receive

The signal from the antenna passes through a 5 pole, low-pass filter which is common for both transmission and reception. This consists of L11, L12, C74, C75 and C76 which attenuates signals above the 40 meter band. The signal passes through C1 which blocks the DC voltage comes from the TX attenuator circuit (R1, L1, R2).

On transmit the "+12 V RX ATT" voltage drives the diode D1 into conduction and part of the received signal is routed to ground through R1.

The resulting signal level is inversely proportional to the value of R1 providing the required amount of attenuation. R2 limits the current flowing through the diode D1, L1 acts as an rf block to R2 and C3 decouples the RF to ground.

Going back to C1, the receive signal passes through C2 to the low impedance input winding of T1. A pair of back to back diodes (D2, D3) are provided to limit the input signal swing to approximately 0.6V. The high impedance coupling of T1 output winding forms a parallel resonant circuit together with C4 at the working frequency.

Note: in an elementary way, we can say that a parallel LC resonant circuit passes all signals to ground except that at the frequency of resonance, in this case, all signals other than those of the desired operating frequency.

The signal then encounters another parallel resonant circuit formed by the high impedance of T2 and C6. Capacitor C5 is a low capacity between the two high impedance parallel circuits and prevents the degradation of the circuit's "Q" (quality factor).

The transistor Q8 provides "RF RX MUTE" during transmission, this prevents the TX signal being reintroduced into the modulator IC (IC2) during transmit.

During receive mode still, at this point via C7, we have an input impedance appropriate for the receive mixer IC2. The input signal reaches IC2 input "INa" (pin 1), and the other input of IC2 (pin 2) the latter which you can consider as grounded for the purposes of RF via C13.

As the VXO LO signal is connected through C21 RL1a and the pin 6 "OSC1" of IC2 the input signal will now mix with the LO. At "OUTB" (pin 5) we will find all the frequencies which result from the mixing of the local oscillator and the input frequency. The wanted signal is chosen and is filtered by the IF 4.915Mhz crystal ladder filter. This is formed by C5, X1, C16, X2, C17, X3, C18, C19 and X4. The nominal bandwidth of the filter is 2.2 kHz which is suitable for SSB signals. The filter output is connected to the input pin 1 (Ina) of IC3 SSB demodulator. The BFO signal from the BFO is fed into IC3 pin 6 via C22 from RL1b.

Pin 5 (OUTB) of IC3 will now carry the recovered audio signal resulting from the mixing of the IF frequency and the BFO 4.915Mhz.

Note: To better fully understand the process of SSB modulation and demodulation it would be worthwhile reading specific literature on the subject.

The demodulated audio signal is coupled through R13, C27 and R14 to the negative input "IN-" (pin 2) of IC4 (operational preamplifier and filter). IC4 is powered during receive via the "+12 V RX" onto pin 7 through R18 and D5. The supply rail is also connected to the non-inverting input IN+ (pin 3) of the operational amplifier IC4. The rail is divided by the resistive divider R15-R16, while C29 and C30 filter the DC ensuring no instability. The diode D5 prevents the voltage on C30 etc from discharging into the other parts of the receive circuitry when the mode changes to transmit.

Apart from the audio amplification obtained by operational amplifier IC4, there is a filtering effect produced by "negative feedback" from the output (pin 6) to the input (pin 2), since the network of R17 and C31 in parallel lets one certain range of audio frequencies back to the input. Being on the

negative input of operational amplifier, the output signal from the IC is in opposite phase with the input and cancels.

The audio output of the preamp IC4 (pin 6) goes to the input of the audio power amplifier IC5 (pin 3) via C32 and potentiometer P3 (volume control). At that point in the circuit, there is a mute circuit which is transistor (Q1). Grounding the audio signal when the line of "+12 V TX" turns on the device through R20. C34 is added to ensure a small delay in change over timing.

The total gain of the stage is determined by IC5 "RGAIN" 1K and C33 connected between pins 1 and 8. Capacitor C37 in series with R22 between the output (pin 5) and Pin 8, form a simple filter that overrides the higher frequencies of audio. The output to the loud speaker is from pin 5 through C36. The network R21 and C35 protect the IC against possible spurious or parasitic oscillations.

Transmit

Similar to the operational amplifier and preamplifier IC4 acting as the receive audio filter, the microphone signal is preamplified by IC1. Its output (pin 6) is connected to the INa input (pin 1) of IC2. This IC now acts as a balanced modulator, since the BFO signal comes through RL1b and C21 at pin 6 "OSC1".

The set P2, R8 and R9 allow adjustment of the DC voltages for the balanced inputs INA and INB (pins 1 and 2), so that, in the absence of any modulation signal input, the residual output signal of the balanced modulator circuit is at the minimum possible level.

This adjustment is known as the carrier suppression setting. The output signal of the balanced modulator is a 4.915MHz DSB (double-sideband) signal. This signal is then passed through the quartz filter network (C15, X1, C16, X2, C17, X3, C18, X4 and C19) which eliminates one of the sidebands (in this case the upper sideband). This then enters IC3 (pin1) which now acts as a mixer with the VXO signal via RL1a and C22 to the pin 6 "OSC1".

The mixture of the IF signals of 4.915MHz and the Local Oscillator target VXO of 12.000MHZ then goes via C52, through the transistor "pre-driver" Q5. This device that only amplifies the signals in the 7MHz range since its collector is tuned as a band pass LC circuit formed by T3 and C56. The base of Q5 is biased by R34 and R35. Next, the signal passes through C57 and is filtered again by another parallel resonant circuit formed by C58 and T4. From the secondary of T4, the signal passes through C61 into the broadband amplifier Q6 which acts as a driver. The base bias for Q6 is provided by R39, R40 and R42 from the regulated voltage supplied IC8. The broadband transformer T5 in the collector circuit of Q6 matches the impedance at the base of transistor Q7, the final output amplifier.

This transistor is also configured as a broadband amplifier by the broadband transformer T6, ensuring that the collector impedance matches that of the low pass filter (C74, L11, C75, L12, C16) via RL2b and ultimately the antenna output.

The base bias for Q7 (Final amplifier) is adjusted by P4, the voltage coming from IC9 and limited by R45 and D6 to around 0.6-0.7V.

P4 adjustment varies the quiescent current of the Q7, this current being adjusted so that the transistor works in an area of their linear curve for suitable for signal amplification for SSB. This mode of amplification is referred to as "AB".

The quiescent current of Q7 (no signal applied to the audio input) is measured directly in the collector circuit of Q7 via the jumper J2. A suitable current measuring meter should be connected to this jumper and with transistor used (2SC5739) the quiescent current must be adjusted to around 50mA. The meter can then be replaced by a link across J2.

IC2 and IC3. Dual function (reversible)

The most interesting part of the ILER-40 giving it some "uniqueness" in regard to the circuit theory is that each of the NE602 integrated circuit performs a different function according to if they're in transmission or reception mode. In RX mode the first NE602 (IC2) acts as a mixer (signal in from the VXO) and as a DSB modulator in TX mode (using the BFO signal). In RX mode the second NE602 (IC3) acts as demodulator (using the BFO signal) and in TX mode it acts as a mixer (using the VXO signal).

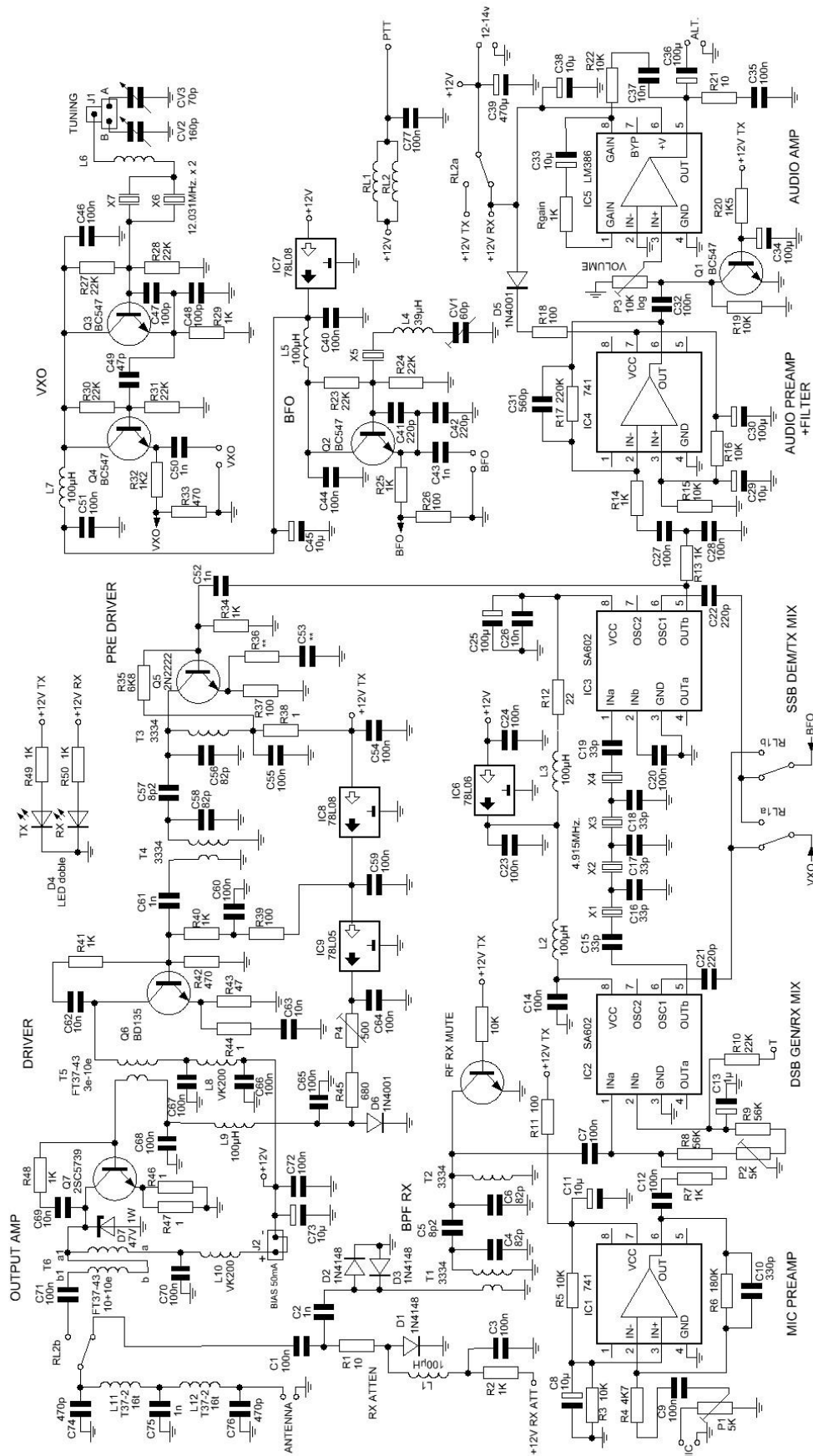

On the air with QRP

Some amateurs, who have never worked QRP and are used to their rigs delivering about 100W to the antenna, ask: how far can you go with only 4-5W SSB?

Indeed, those who have not worked QRP have little belief that contacts of any distance can be achieved with just a few watts. It mainly depends on the antenna type, the location of the station and the operator technique. However, all these assumptions are more or less important depending on the propagation conditions prevailing at the time. They are really what ultimately determine the distance of our contacts.

We have only to compare a 100W signal with a 5W signal.

If we receive a station which is broadcasting at 100 W with an S-9 +20 dB signal and it reduces power to 5W, you'll still receive it with an S-9 +7 dB signal. Does that seem incredible? Well that is the actual signal loss. If the output power is reduced further, for example to 1W, the signal will still be an S-9. The bottom line is very simple: 100W down to 1W (100 times less), we observe a decrease of 20 dB in the signal received

The next four points require clarifying with a little maths.

- 1.- A "S unit" on a meter normally means an increase or decrease of the received signal by 6dB.
 - 2.- This means the transmission power must be increased by 4 times to increase the signal by 1 S unit
 - 3.- Consequently, a power reduction of 4 times means a decrease of the received signal of 1 S unit
 - 4.- S9 decibels: A 10dB increase on an S9 signal (S9 +10 dB) needs a power increase of 10 times!
- Now let us consider a real example with normal propagation conditions where a station with 500W output power is received as an S8, What can we expect with the same station if it runs low power QRP?

Transmit power	S meter reading
500W	S-8
125W	S-7 (¼ previous power)
31.25W	S-6 (¼ previous power)
7.8W	S-5 (¼ previous power)
1.9W	S-4 (¼ previous power)

These examples ultimately show that when stations are transmitting at high powers, and are received at a good signal level, just a few simple mathematical calculations show us that a 2W or 4W station can also reach a more than acceptable signal level at the receiving end.

Do not forget either that a QRP station with a good antenna and a good location may well be stronger than a QRO station with a poor antenna giving a poor performance or in a bad location.

Remember also the importance of the local environmental QRM levels. In urban or industrial areas especially, these can significantly degrade the reception.

Simply if we are being received at S-4 but the QRM is S-6, we hear nothing.

73 Javier Solans
ea3gcy@gmail.com