



**KANGA
PRODUCTS**

'Rooster' CW 80m, 40m, 30m, or 20m Transceiver Kit Manual and User Guide

Rev 12 19/09/2024



Easy Build 80m, 40m, 30m, or 20m Crystal controlled
Transceiver.

Direct Conversion Design

Part Pre-installed SMD design

approx 20 parts to fit, No coils to wind!

Single Frequency Crystal controlled operation

Front panel RIT control

approx. 2.5Watts (80m), 2 Watts (40m),

1.5 Watts (30m), 1 Watt (20m)

Active Audio Filter

Sinewave CW Sidetone

Visual RX/TX indicator

10.5-14v DC Operation

Supplied with Strong Aluminium Case



These instructions are for all Kit versions of the Rooster

Introduction

Welcome to the Rooster. The Rooster is designed to be a single evening project that will be fun to build and even more fun to use. The Rooster is intended to be a replacement for the FOXX3 kit Kanga offered for many years. The FOXX3 was very popular but had a few issues that we wanted to address with its replacement. We wanted a simple transceiver kit that offered better sensitivity and selectivity, more power and a purpose made enclosure.

The Rooster was first offered at the RSGB convention in 2023 to beta testers and following feedback the Rooster design was updated to this version. Now available for 80m, 40m, 30m or 20m.

The design is based around a standard SA/NE612 front end mixer/oscillator with an op-amp audio amplifier and active audio filter. The transmitter also shares the NE612 oscillator and buffers the VFO signal before feeding it to a high gain PA stage giving approx. 2.5 watts of RF on 80m, 2 watts on 40m, 1.5 watts on 30m or 1 watt on 20m.

The kit uses a mix of SMD and through hole parts, ALL the SMD parts are pre-installed but still leaving about 20 parts to fit to complete the transceiver. The kit can be completed in around an hour by an experienced builder but slower builders may want to consider it as a weekend project, would be a good choice for an intermediate level build-a-thon option.

The Rooster will require a suitable antenna with a low SWR.

Disclaimer

The kit is designed to be built by Ham radio enthusiasts and in order to use the finished product you need to hold a valid ham Radio licence that permits operation on the Rooster frequency in your locality.

We offer the kit as is and do not guarantee the kit assembled by yourself can meet your local regulatory requirements, including spurious, environmental or other requirements.

I suggest that you always use the online version of the instructions, they are updated from feedback from builders as its received and of course are in full colour which helps the build.

Parts Inventory

The parts are presented in a long strip of clear tubing, separated in sections. Each section covers a small number of stages in the instructions, only open the section you are working on at that time so you don't lose any parts. Start at the end with the DC connectors and 3.5mm PCB sockets.

[Common Main Section Parts](#)

Item	Qty	Value	Comment
Enclosure	1	Rooster Aluminium Case	Enclosure
PCB	1	Rooster PCB	SMD Parts Pre-fitted
Parts Pack Section 1			
DC PWR SKT	1	2.1mm DC Power Socket	PWR
3.5mm Jack	2	3.5 mm Stereo Type	PHONES/KEY
Capacitor	1	10nF MLCC Cap	C16 (See Stage 3 Notes)
Q4	1	2N3906	Transistor Q4
Q5	1	2N4401	Transistor Q5
Diode	1	PA Protection Diode	D6
Parts Pack Section 2			
NE602	1	Mixer IC on adapter board	IC1
4 Way Strip Pins	2	Mixer Mounting Pin Strips	Strip Pins (may be fitted to IC1)
IC Socket	1	8 way IC Socket	IC1
Parts Pack Section 3			
RIT	1	10K Potentiometer & Knob	TUNE
BNC	1	BNC Screened Socket	ANT
Thermal Pad	1	T226 Thermal Pad	Thermal Pad
Q6	1	2SC1162 (2SD882 on 20m kit)	Transistor Q6 PA Transistor
LED	1	Dual Colour LED	LED
Feet	4	Rubber Feet	Feet
Parts Pack Section 4			
Rooster Front Panel	1	Front Panel	Punched and printed
Rooster Rear Panel	1	Rear Panel	Aluminium Rear Panel
Parts Pack Section 5			
M3 Nut	1	M3 Black Nut	PA transistor Mounting Nut
M3 Screw	5	M3 Black Screw	Panel Screws



Band Packs:-

80m Pack

Parts Pack 80m			
L1	1	100uH	Brown, Black, Brown, Gold
L2	1	10uH	100 radial Inductor
L3	1	2.2uH	Red, Red, Gold, Silver
L4	1	2.2uH	Red, Red, Gold, Silver
L5	1	6.8uH	Blue, Gray, Gold, Silver
XTAL	3	80m Crystals	2 low profile, 1 standard HC49 size
TRIMMER	1	NOT FITTED	C26
Capacitor	1	33pf	C28

40m Pack

Parts Pack 40m			
L1	1	100uH	Brown, Black, Brown, Gold
L2	1	10uH	Brown, Black, Black, Silver (See Notes)
L3	1	1uH	Brown, Black, Gold, Silver
L4	1	1uH	Brown, Black, Gold, Silver
L5	1	3.3uH	Orange, Orange, Gold, Silver
XTAL	3	40m Crystals	X1, X2, X3
TRIMMER	1	4-20PF Trimmer (Red)	C26
Capacitor	1	100pf	C29

30m Pack

Parts Pack 30m			
L1	1	100uH	Brown, Black, Brown, Gold
L2	1	6.8uH	Blue, Gray, Gold, Silver
L3	1	0.68uH	Blue, Gray, Silver
L4	1	0.68uH	Blue, Gray, Silver
L5	1	3.3uH	Orange, Orange, Gold, Silver
XTAL	3	30m Crystals	X1, X2, X3
TRIMMER	1	6-40PF Trimmer (Yellow)	C26
Capacitor	1	470pf	C28



20m Pack

Parts Pack 20m			
L1	1	100uH	Brown, Black, Brown, Gold
L2	1	6.8uH	Blue, Gray, Gold, Silver
L3	1	0.47uH	Yellow, Voilet, Silver
L4	1	0.68uH	Blue, Gray, Silver
L5	1	0.68uH	Blue, Gray, Silver
XTAL	3	20m Crystal	X1, X2, X3
TRIMMER	1	6-40PF Trimmer (Yellow)	C26
Capacitor	1	100pf See Note >	C28 (1nf for boards from 17/7/24)
PA Transistor	2	NEC D882 (High Gain Ver)	882 Due to low cost of these transistors I have included a spare !

Note regarding 80M Rooster

The 80m Rooster does not use the variable trimmer capacitor that other band Rooster have fitted. The 80m crystal has a limited 'pull' range and although using the trimmer would allow the crystal to be set to exactly the QRP COA freq but then the receiver offset would be to small. Without the trimmer fitted the 80m frequency will be within a few 100Hz of the COA which will allow a much wider offset for receive (Typical tx freq will be 3.560.2Mhz on our prototypes)

Important

The Rooster is a relatively easy to build transceiver BUT you need to carefully follow the instructions, do not move on a stage until you are sure that you have completed the previous stage correctly and fully. All parts must be fitted neatly and their leads trimmed flush. **I cannot stress strongly enough that unless you follow the instructions and make sure that each part is fitted correctly as indicated in these instructions you will not successfully complete the kit.**



Get familiar with the main PCB.

The photos are showing the 40m Board, when there is a difference the instructions for the 80m/30m/20m build will show the different steps needed. The difference is really the crystals and the Low pass filter values. Due to continuous development your board may differ slightly from the photos below.

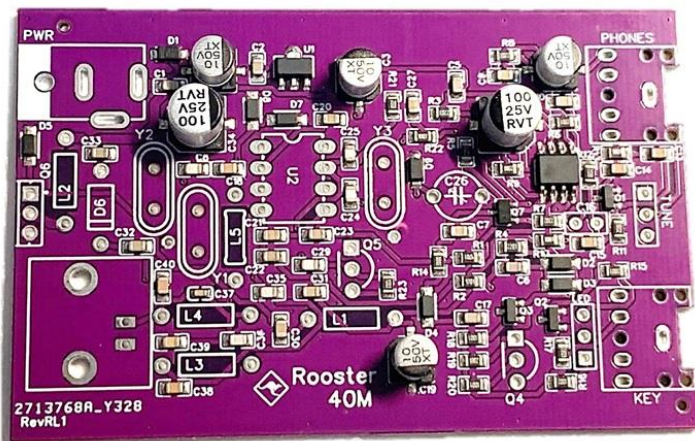

You can see many parts are pre-fitted for you, there are about 20 parts left for you to fit. Some of the parts are close together so you will need to take extra care when soldering, make sure all the parts are fitted flush to the board if the instructions call for it and trim the leads as flush to the board as you can. There is not a lot of room under the board when fitted in the case.

When fitting parts do not bend the leads so that they are flat against the board to hold them in place. A slight bend of the leads is all that is needed to hold the part in place while you solder it. Bending them flat against the board and soldering/trimming increases the chances of forming shorts to the ground layer.

The parts for the kit are in a number of sections, start with section 1. That is the end with the DC and 3.5mm sockets, this will cover the first few stages of the build.

Section 1 :- Stage 1 - 3

Section 2 :- Stage 4 – 5

Section 3 :- Stage 4 - 5

Section 4 :- Stage 6

Section 5 :- Stage 7 - 14

Section 6 :- Stage 7 - 14

Section 7 :- Mounting screws (Case/PA transistor)

You will also receive a separate band specific bag of parts. This will depend on which version you are building, the 80m, 40m, 30m, or 20m version.

Band Specific Parts Bag :- Stage 4 and Stage 6

Most of the photos below show the 40m Board, if you are building other versions your board may be slightly different.



Stage 1 :- The DC input socket

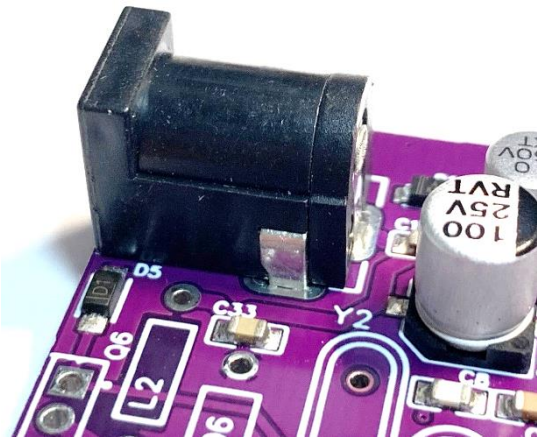

The first part of the build is to fit the DC socket.

The socket must be fitted so that it's flush to the board and level with the edge of the PCB, the position for this is labelled PWR on the board. It must be square to the edge of the board as shown here. The silk screen printed layout can be used to make sure it is positioned and aligned correctly.

Solder one pin first on the bottom of the board and check the part is correctly fitted. Once you're happy that it is right, solder the remaining two other pins.

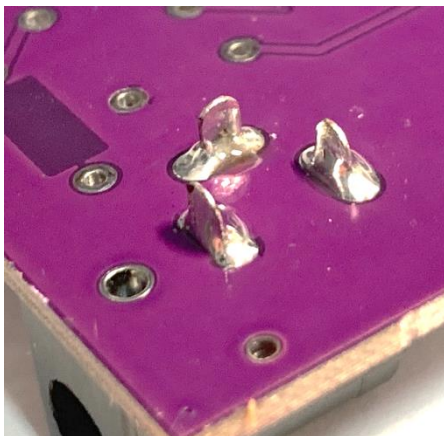

Here is what you should have now.

The 3 legs are now much too long, they would short out when fitted into the case. Use wire trimmers and cut the soldered pins flush to the board.

Do not move on a stage until the current stage you are working on has been completed correctly. The biggest problem identified with the beta testers was poor soldering and rushing to get the kit built. Do not take short cuts. Each part is as important as the next. Save yourself problems later by taking care at each stage.

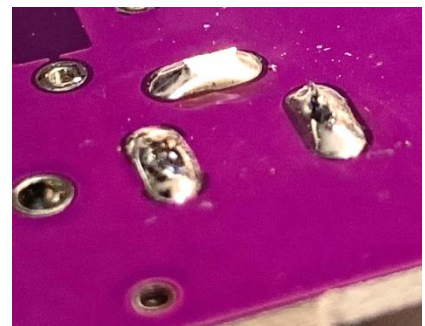

Testing your work

If your Rooster fails ANY test stage, STOP ! if it doesn't do what it should it will never do so and finding out why will be much harder. Contact me if you have a problem.

Ok we have only fitted one part but that will allow us to do some basic testing on the board.

We can test the voltage regulator and DC distribution now.

I suggest using a current limited supply if you have one and monitor the current the board draws.

For all the following test I have used a 12v DC supply.

Apply 12v to the board via a suitable power lead (Centre pin positive) to the DC input socket of the board (2.1mm plug needed)

The current consumption should be just a few milliamps, the overall finished receiver will be around 20-25mA when complete.

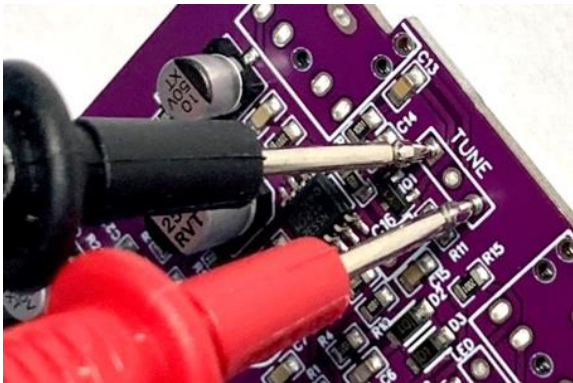

On the front edge of the board you will see the position for the RIT control (labelled Tune). Use a **DC Volt meter** to measure the voltage across the two outer pads for this control. You will see about 1 volt less than the supply voltage so approx. 11v with a 12v supply.

Next we can check that the voltage regulator is working correctly.

Check the voltage on position for U2 (that will be the mixer chip NE612).

Measure across Pin3 (0v) a Pin 8 (+V).

You should see 8V.

That completes the first stage and the first tests.

Important

Now turn off the power and unplug all the leads before you move on to the next stage. After each stage of testing remember to unplug all leads from the Rooster!

Take the same care with each of the following stages.

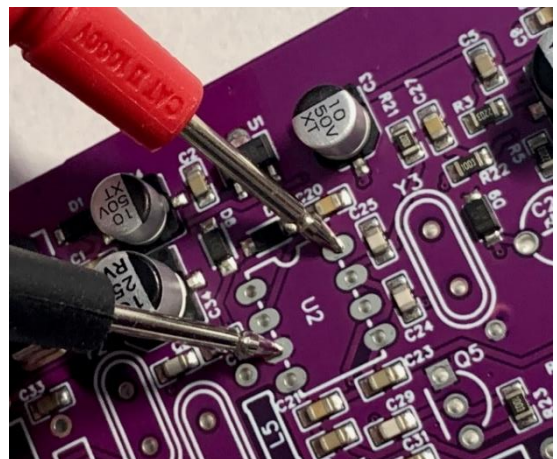



Stage 2 :- Phones and Key sockets

The two jack sockets are used for the key and the headphones. They fit right on the front edge of the PCB. Both sockets are the same type.

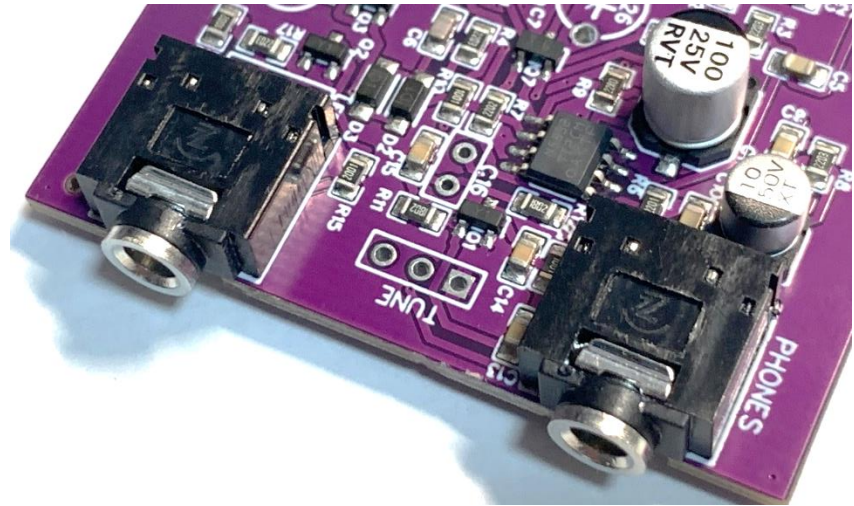

Fit them one by one. Make sure that all the pins pass through the board and none are folded over when you fit them. The socket **MUST** be flush on the board when you fit them, if not they will not line up with the holes in the front panel later.

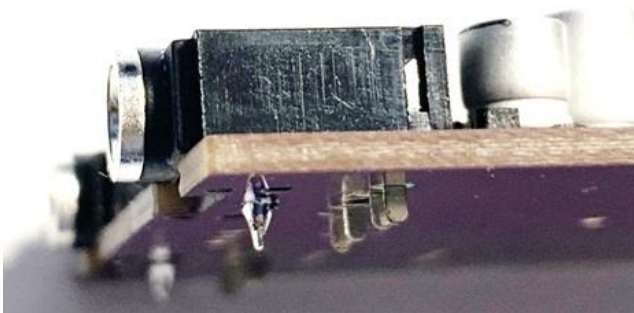

Solder just one pin on each socket first, then double check the alignment. When sure they are correctly aligned and flush, solder the remaining pins.

Again, after you finish soldering these, cut the pins flush with the board.

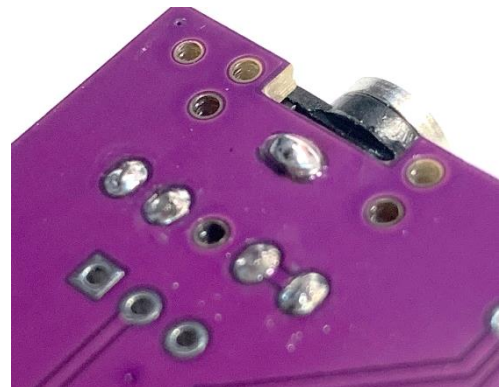

Now we can do a more interesting test on the board.

Since a lot of the parts are preinstalled, we can already test the audio amplifier section.

Make sure that any off cuts are cleared from the work area.

Plug a set of **Stereo** headphones into the 'PHONES' socket and power (12v DC) up the board.

Again check that the current is less than 20mA @12v

Please note : you MUST use stereo headphones as a mono plug will short the audio output.



Now we can perform the 'Buzz' test

With the headphones connected, touch the board with a metal screw driver on Pin 5 of the position for U2. If you touch the shaft of the screwdriver you should hear a loud buzz in the headphones. Repeat the test but this time touch pin 4 of the U2 position

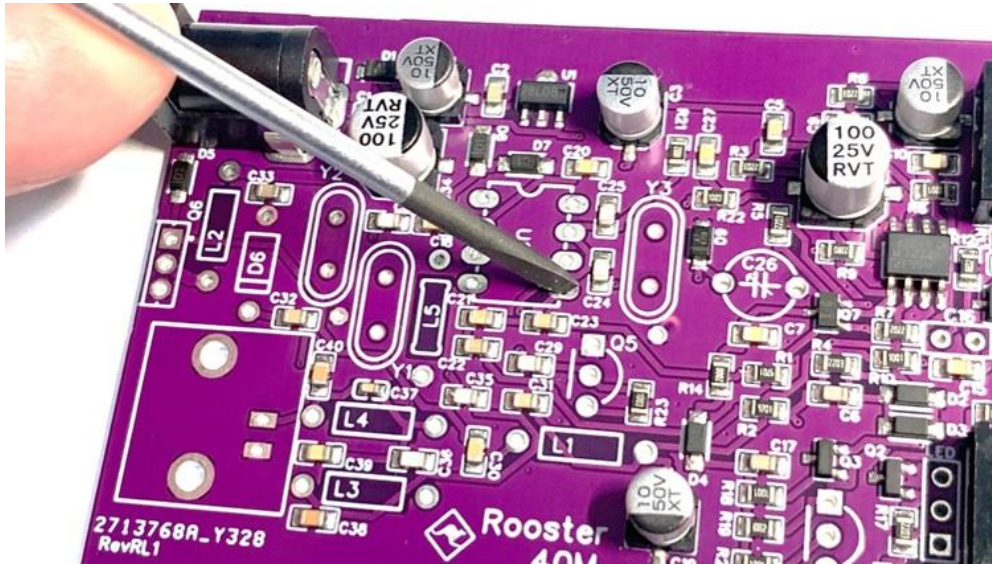

Pin 5 Buzz Test

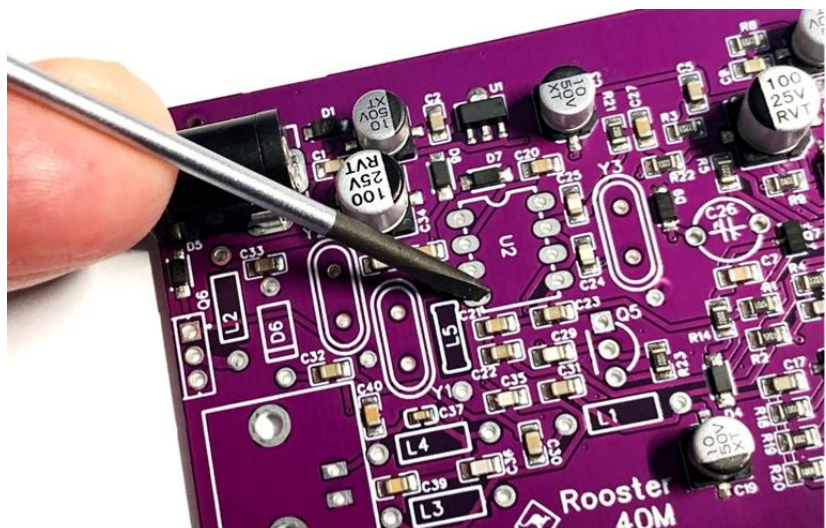

Pin 4 Buzz Test

You may find that Pin 5 produces a louder Buzz than Pin 4.

This tests the audio and filter section of the board so now unplug all the leads and move to the next stage.



Stage 3 :- Side Tone

The Rooster has a sine wave sidetone generator, much more pleasant than many simple radio kits.

The first part we need to fit is a capacitor C16

C16 is a yellow capacitor with a 2.54mm pin spacing,



The value of this capacitor will adjust the volume of the sidetone, we have used a value of 0.01uf (10nF) for this. This capacitor controls the sidetone level, if you find it is too loud you can change this value later, that's why we have used a standard capacitor rather than a SMD part. If you want to lower the volume try values between 1nf and 10nf.

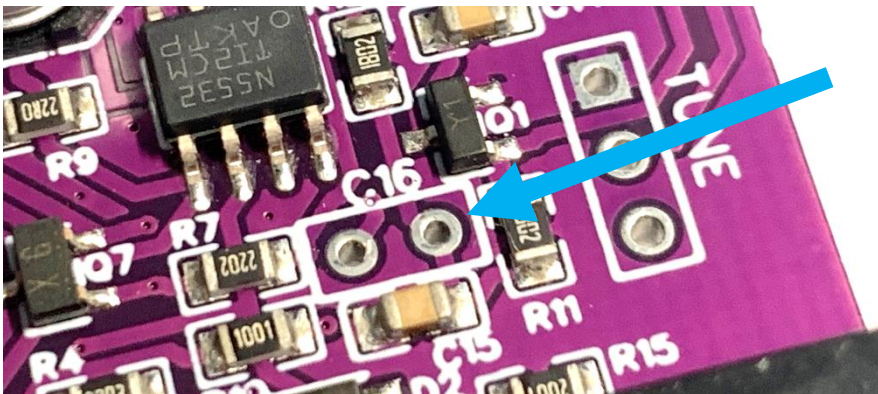

C16's position is just behind the Tune Control location near the front of the board.

Put this capacitor in its location and **slightly** bend the legs apart under the board, this will stop it falling out

when you turn the board over to solder it. Solder one lead first and re-check it is still sat down correctly on the board. When happy solder the second leg and trim the leads flush on the board.

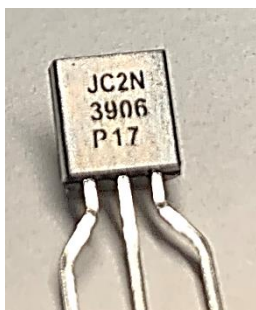

The next part is a transistor, **IMPORTANT !** many different transistors all look just the same. Look on the flat side of the transistors in this kit and check you select the right one for this, you need to find the **2N3906**.

This transistor is to be fitted in position Q4 on the board, it's just behind the KEY IN socket. Be careful not to fit it in the position for the LED!

Make sure you put it the correct way round, the outline on the PCB shows the way it must be fitted.

Push the part down to the natural stop point, don't force it! It will sit about 3mm above the board. Bend the two outer legs outwards so the part doesn't fall out when you turn the board over.

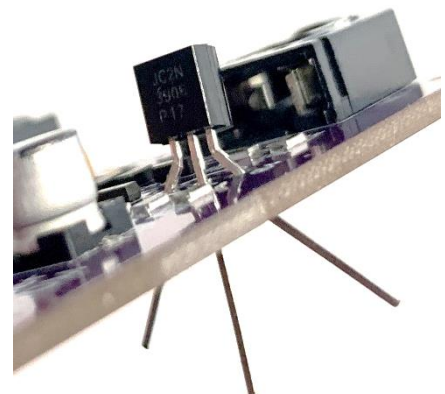

Solder the centre pin first and check the alignment of the transistor it should sit nice and square on the board. When you're happy it looks right, solder the other two pins and trim the leads flush.

Now we can test the sidetone circuit.

Plug in the headphones and key.

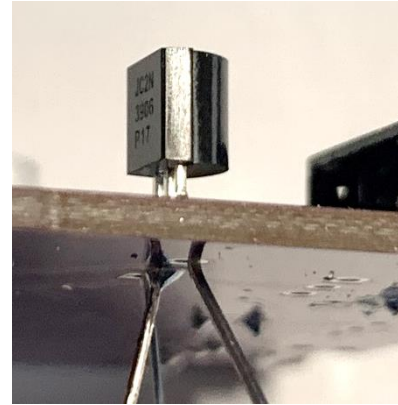

Next the DC supply.

Tap the key and you should hear the sidetone. **IF** you wish you can test the muting circuit too at this time. Perform the 'Buzz' test again but while listening to the 'Buzz' tap the key. The sidetone should replace the buzz.

Stage 4: Driver and PA Protection Diode

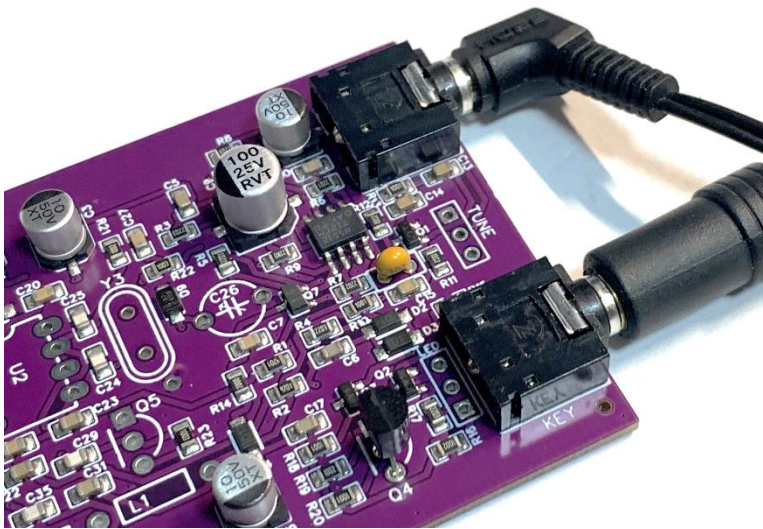

Now fit Q5 transistor, make sure it is the right one, it should be a 2N4401. Check the printing on the flat of the transistor. And fit it as you did for Q4 before.

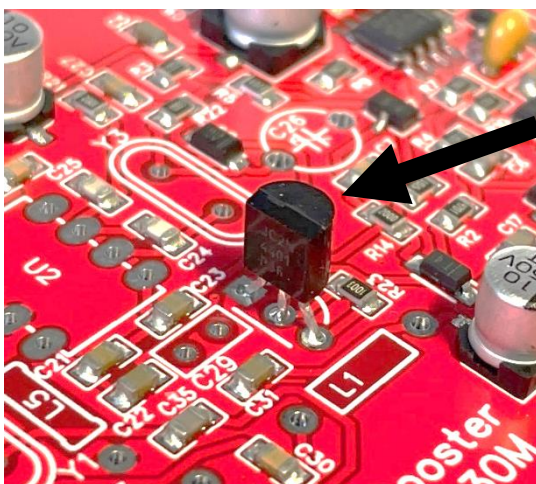

Make sure it is fitted to match the outline on the PCB and that it is sat squarely as per the picture here.



We now will fit a protection diode that will help protect the PA from high SWR. This is D6.

Shape this diode ready to fit first.

Bend the leads about 3mm from the body. Take care doing this. The diode has a glass body and you could break it if you're too rough.

You will note that this diode has a black band on one side, this is VERY important.

The diode must be fitted so that the band is in line with the line on the symbol on the PCB for D6.

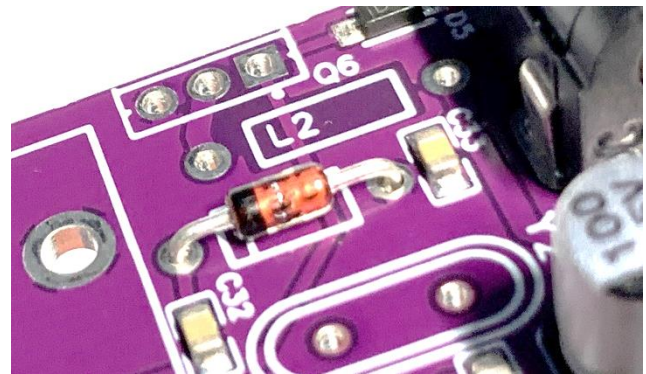

Stage 5 Mixer

The Rooster uses an active mixer circuit that has much better performance than the old FOXX3 ever could offer. We need to fit the 8 pin socket for this chip.

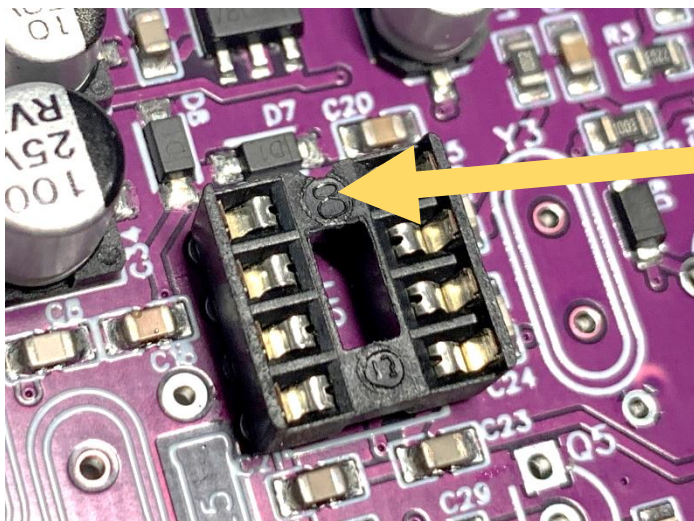

The socket, if you look carefully, has a small notch on one of its shorter edges. This notch must be next to D7 on the PCB. Make sure that the socket is flush down on the board. I solder one pin first and double check before soldering the other pins.



Preparing the Mixer Chip

Your chip **MAY** be already assembled with the two strips of pins if not follow the instructions below

The mixer chip is provided on a small adapter PCB, this is a SMD part but its pre-fitted to the small board.

We need to fit this board with two strips of pins.

It's an easy job so don't worry about it. The kit comes with the mixer chip mounted on a small PCB and two strips of 4 pins. The pins have legs on both sides of the black band in the centre.

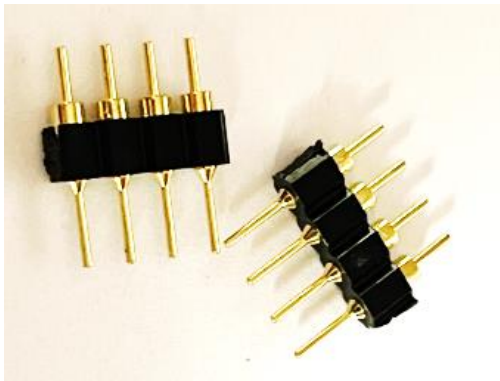

One side has longer legs, and the other side has larger round flat posts with a shorter leg protruding from them. (see photo here) . The long leg side should be pushed into the socket you have just fitted.



Now place the small board onto the pins,



Make sure you fit it the right way round, pin 1 should be to the left side of the board nearest to the larger electrolytic capacitor. Sold just two pins first, on opposite corners. When happy that the adapter board is flat and correct solder the remaining pins. Double check no pins have solder bridges between them.

Now it's time to open the band specific parts bag.



*****Important Note*****

If you have the latest batch of PCB's you will find C29 (C28 on 80/ 30/20m versions) will not be pre-fitted. This is to allow the Rooster to be built for LOWER power use. You will receive a standard value capacitor (33pf for the 80m version, 100pf for the 40/20m version, 470pf for the 30m version) with the kit (in the band specific parts bag) this will give the normal output power levels but if you wish you can fit a lower value (10pf for 80m, 22pf for 40/20m or 100pf for 30m) user supplied if you want QRPP power levels.

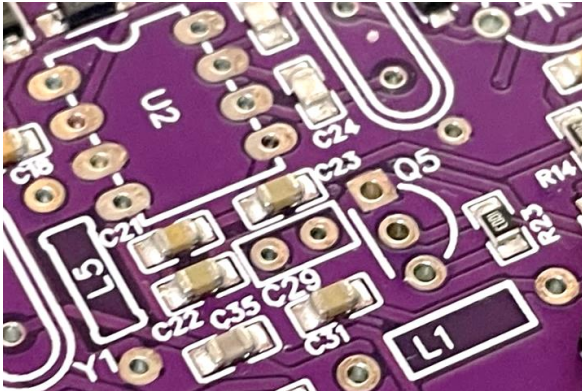

Fit the C29/C28 (Value as above) capacitor now and trim the leads at the back of the board.

Please don't be tempted to fit a larger value capacitor in order to get more power. You will most likely blow the PA transistor or cause 'chirp' on your transmission. The difference you could achieve would only give you 1dB or

so increase for a lot more risk.

Next, we need to fit the trimmer capacitor (NOT FITTED on the 80m). Its colour may not be as shown in the photos here (if you not reading black and white paper instructions!) a suitable trimmer will be in the band specific parts bag. Its value will be selected to match the crystals supplied with the kit (40m, 30m, or 20m).

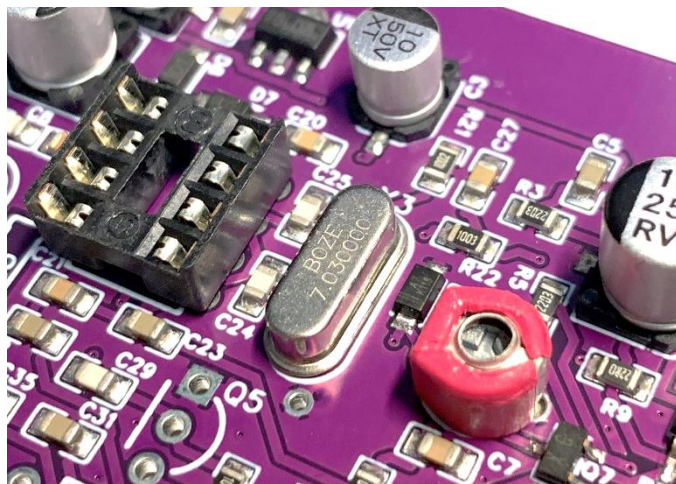

Important! If using a **RED** trimmer in your kit turn it over and look at the bottom, if it's also red then mount the trimmer so the flat edge is nearest to the crystal position.

If the **RED** trimmer has a white bottom then turn the trimer round and fix it with the flat edge is nearer to transistor Q7.

For all other colour trimmers the flat edge should be positioned next to the

crystal slot as shown here. Don't worry, you haven't missed fitting the crystal, we will do that next

The Crystals.

The supply of crystals has been a little variable up to now, so I may supply the crystal pack in a few different ways.

The kit uses three crystals, two in the front-end filter and one for the mixer. The crystals in your band pack are all the same frequency but some of the characteristics can be different. Sorry if this stage seems confusing, read it a couple of times to be sure you understand what you need to do.

If in doubt contact me (sales@kanga-products.co.uk)

The Crystals can be supplied in a few different formats, if all crystals are the same size any can be used in any position **UNLESS** one of them has a coloured top. In that case the coloured top crystal must be used in the mixer stage.

2) You may get your crystals supplied in two different sizes, if so, use the two same size ones for the front-end filter and the odd one out for this mixer (Y3) stage.



Whichever format your crystals are supplied in the performance will be the same.

This mixer crystal (Y3) is to be fitted between the chip socket and the trimmer as shown above.

The Mixer IC

The mixer chip used on the Rooster is getting very rare in its DIP format, but it's still available in SMD format.

I have supplied this chip pre-fitted to a small adapter board. This assemble can be treated as a DIP chip now. Just be sure you check which end is Pin 1 (marked on the adapter board).

CAREFULLY plug the board into the socket on the board.



RF Noise Test

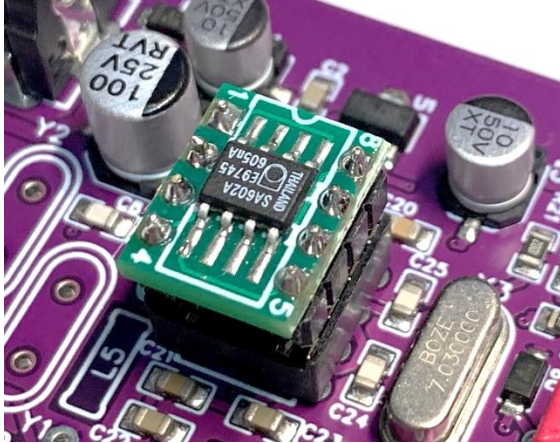

Now again make sure that the chip is plugged in the socket the correct way round.

The adapter board has Pin1, 4, 5, and 8 marked. Make sure Pin 1 is nearest to the DC in socket.

Connect up the headphones/key and power again as before. Now use a metal screw driver and touch the top pin for the Y2 crystal position. You should hear a mix of Hum and RF noise, you may even hear some weak CW signals! Don't forget to remove the leads after this test!

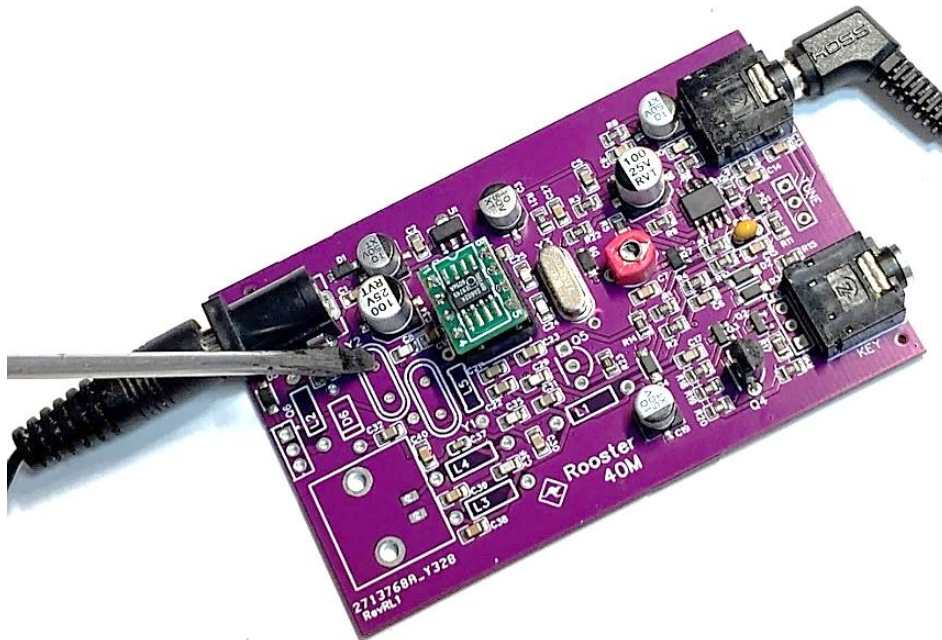



Stage 6: Fitting the 5 inductors **(READ THIS SECTION CAREFULLY!)**

The value of the inductors will depend on which band pack you have.

We will break this section down for each band. **Read this section TWICE BEFORE you fit anything. Follow the details for the version you have (80m, 40m, 30m, or 20m).**

80m Band Instructions

(Only Follow if building the 80m version!)

This stage is the easiest to make a mistake with so read and then re-read this section **before** you fit any. There are 5 inductors and unfortunately most are very similar in colour bands.

We need to be 100% sure that the right one is used in the right place.

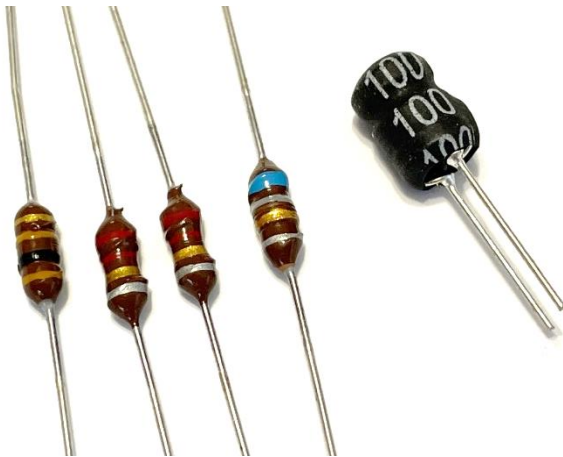

Take time and care with this stage, it is hard to remove parts once fitted.

The inductors used on this kit use the same colour bands as resistors to identify their value so you can use the colour resistor code chart that came with the kit to help you.

Please note, these inductors have a dark brown body, the brown strip on the inductors is lighter in colour and to

me looks more coffee colour so take care.

Don't fit any yet, let's just check the values.

L1 is 100uH it has bands that are Brown, Black, Brown and the last one is Gold.

L2 is a 10uH inductor, this part is a radial leaded type inductor and fitting is a little different (see later in the instructions).

L3 and L4 are both the same value 2.2uH with bands of Red, Red, Gold, Silver

L5 is a 6.8uH inductor, easy to spot, its bands are Blue, Grey, Gold, Silver.



40m Band Instructions

(Only Follow if building the 40m version!)

Right, back in band specific parts list I put see notes against L2, well this is the Note!
On some new boards we are supplying a radial mounted inductor at L2. This vertical version is being supplied now on some 40m and below Roosters.

This stage is the easiest to make a mistake with so read and then re-read this section **before** you fit any. There are 5 inductors and unfortunately most are very similar in colour bands.



We need to be 100% sure that the right one is used in the right place.

Take time and care with this stage, it is hard to remove parts once fitted.

The inductors used on this kit use the same colour bands as resistors to identify their value so you can use the colour

resistor code chart that came with the kit to help you.

Please note, these inductors have a dark brown body, the brown strip on the inductors is lighter in colour and to me looks more coffee colour so take care.

Don't fit any yet, let's just check the values.

L1 is 100uH it has bands that are Brown, Black, Brown and the last one is Gold.

L2 is a 10uH inductor , Its bands are Brown, Black, Black, Silver.

On the latest kit I have changed this part to a radial leaded type inductor and fitting is a little different (see later in the instructions).

L3 and L4 are both the same value 1uH with bands of Brown, Black, Gold, Silver

L5 is a 3.3uH inductor, easy to spot, its bands are Orange, Orange, Gold, Silver.

30m Band Instructions (Only Follow if building the 30m version!)

This stage is the easiest to make a mistake with so read and then re-read this section **before** you fit any.

There are 5 inductors and unfortunately most are very similar in colour bands.



We need to be 100% sure that the right one is used in the right place.

Take time and care with this stage, it is hard to remove parts once fitted.

The inductors used on this kit use the same colour bands as resistors to identify their value so you can use the colour resistor code chart that came with the kit to help you.

Please note, these inductors have a dark brown body, the brown strip on the inductors is lighter in colour and to me looks more coffee colour so take care.

Don't fit any yet, let's just check the values.

L1 is a 100uH inductor it has bands that are Brown, Black, Brown and the last one is Gold.

L2 is a 6.8uH inductor its bands are Blue, Gray, Gold, Silver.

L3 and L4 are both the same value 0.68uH with bands that are Blue, Gray, Silver.

L5 is a 3.3uH inductor, its bands are Orange, Orange, Gold, Silver.



20m Band Instructions (Only Follow if building the 20m version!)

This stage is the easiest to make a mistake with so read and then re-read this section **before** you fit any.

There are 5 inductors and unfortunately most are very similar in colour bands.

We need to be 100% sure that the right one is used in the right place.

Take time and care with this stage, it is hard to remove parts once fitted.



The inductors used on this kit use the same colour bands as resistors to identify their value so you can use the colour resistor code chart that came with the kit to help you.

Please note, these inductors have a dark brown body, the brown strip on the inductors is lighter in colour and to me looks more coffee colour so take care.

Don't fit any yet, let's just check the values.

L1 is a 100uH inductor it has bands that are Brown, Black, Brown and the last one is Gold.

L2 is a 6.8uH inductor its bands are Blue, Gray, Gold, Silver.

L3 is a 0.47 uH inductor with bands that are Yellow, Violet, Silver

L4 is a 0.68uH inductor with bands of Blue, Gray, Silver.

L5 is a 0.68uH inductor, its bands are Blue, Gray, Silver.

In the 20m bandpack you will also find a PA transistor marked NEC D882, this is to be used instead of the standard transistor you have in the main bag of parts, These are very high gain versions and I have a high qty of these, due to this I am being generous and will include a spare too. see the instructions later for fitting the PA transistor for more information.

Whichever band pack you have take your time to make sure that you follow the instructions below with care.



Now you know the values read this section again and this time fit each inductor one by one.



To fit them you will need to bend the leads of each inductor at 90 degrees **right next to the body** as shown here. They will then fit correctly on the board.

Update 25/8/24 Only for 80/40m versions

Not all kits will have the new inductor, this will only affect kits

supplied from October 2024, standard inductors will be supplied on kits before that date, there is no need to change this part if your kit has the standard inductor. This part is **ONLY** for the 80/40m versions, the higher band versions use the standard inductor too.



The latest parts list shows L2 as a radial inductor. The PCB isn't designed for such a part but it's still an easy part to fit if you follow the instructions below. To start with locate L2 amongst the other parts in the bandpack, it will be like the photo here.....



We need to shape the leads to allow us to use this part. Bend one leg (either is fine) at 90 degrees to the body.

Now drop the part into place (L2) on the board, only one leg will drop through the fixing hole. The body of the inductor should be nearest to the DC power socket. The photos only show

the inductor on the board, you will have other parts already fitted.



The bent leg should be sticking out over the position marked L2 on the PCB. Lift out the inductor again and now measure 10mm from the straight leg and bend the other leg at this point.



Now the inductor should fit the board as in this photo.



The other inductors can now be fitted as on the parts list.



Here are the inductors fitted to the 40m board (New inductor not shown here), of course if you're building the 30m or 20m version the some of the inductors will be different colours.

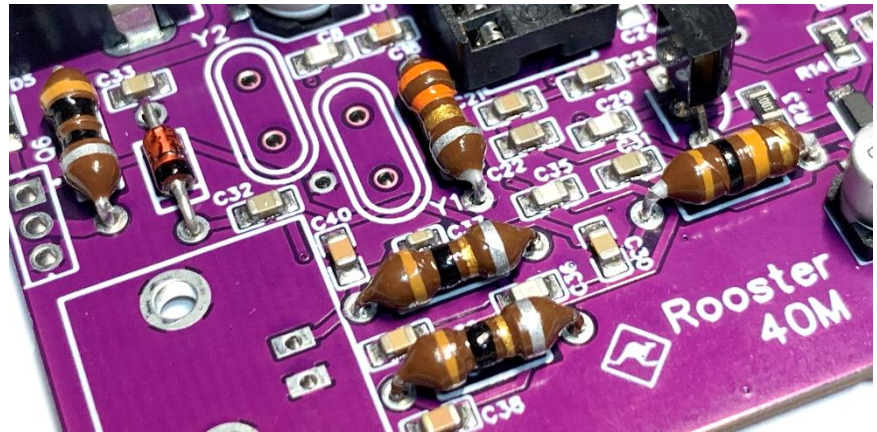

Make sure yours are fitted flush to the board and that the leads are trimmed flush on the back of the board.

Stage 7: Front end bandpass filter

We now will fit the last two crystals, Y1 and Y2 that are in your band specific bag



They are both the same and either can be fitted in either position.

When fitted the board should look like this.

Not much more to do now.



Stage 8: RIT Control

The RIT tune control.

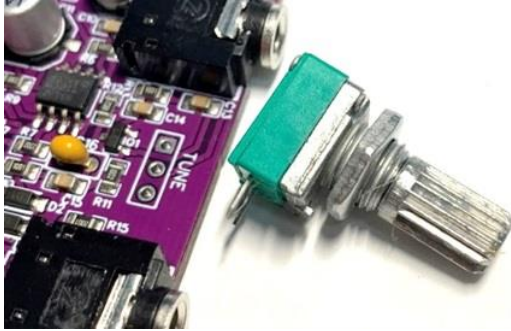

First remove the nut and washer from the front of the control, make sure the 3 pins are not bent over and insert it onto the board. Push the control down so the body is flush to the board. It must be flush to the board or the front panel will not fit!

Solder the centre pin first and check the control is still positioned correctly, when happy solder the two outer pins. Trim the leads flush with the board.

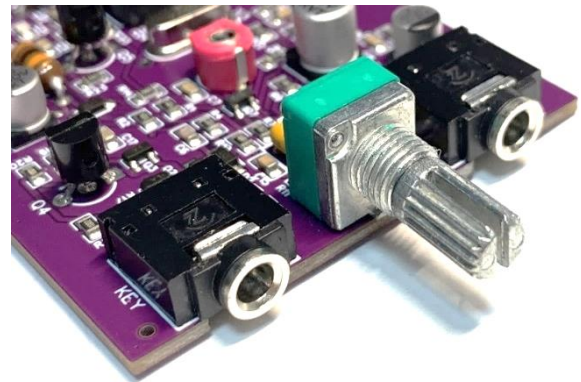



Stage 9: Antenna BNC Socket

Now the final part, maybe the hardest to solder!

The Antenna BNC socket

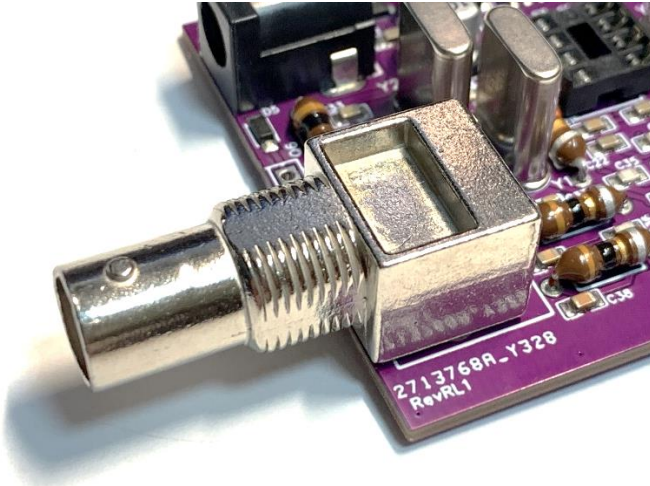

The antenna socket is a heavy item, it is made from metal and is really a big heatsink. It can be difficult to solder the mounting lugs to the PCB. The lugs may have been cut down in length so they don't touch the bottom of the case. This can make them harder to solder too as the ends of the lugs are not pre-tinned. If you just can't solder them (if the soldering iron is not very powerful) then do the best you can, the electrical connection is made via the two thin

pins that pass through to the PCB from the connector. The lugs just make things more stable. When we fit the rear panel the BNC connector will be held in place by the large fixing nut anyway. If you can solder the lugs you will need to keep the iron on the lugs for a prolonged time when soldering so be very careful that you don't burn yourself on the body of it. It will be very hot for a while after you finish soldering.

The latest boards have an extra contact hole for the BNC, this extra hole is there for an alternative socket arrangement that hasn't been used on this version of the Rooster. There is no need to connect anything to this point. This point is only an additional GND connection

When mounting the BNC make sure that the two circuit pins pass through the PCB first and solder these before attempting the two big mounting lugs. Trim these two leads. If possible, press and hold down the connector flush to the board and solder the lugs. (Take care not to burn your fingers!)

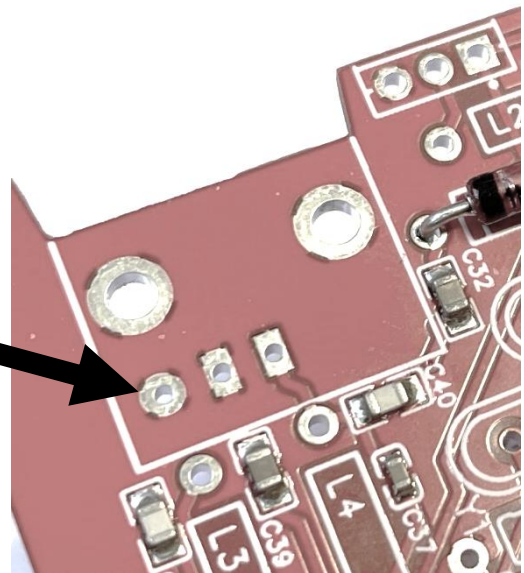



Stage 10: Testing and Alignment

Time for some testing and alignment. The alignment is the same for all versions, only the frequency will change.

If you removed the mixer chip earlier for safety now is the time to replace it.

Please understand something important now. This radio is intended to be used in the QRP area of 80m, 40m, 30m or 20m. The COA (Centre of Activity) on 80m is 3.560MHz, 40m is 7.030MHz, 10.116MHz on 30m, and 14.060MHz on 20m. You do not need to worry about being bang on these frequencies, there is nothing magical going to happen if you're sat on that spot frequency. I have considered swapping the crystals to be 1 or 2 KHz off the COA to reduce congestion in that area. The crystal supplied will not give you that much adjustment but if you find yourself a few hundred hertz off the 'spot' don't worry, be happy!

80m Note

The supplied 80m crystal used in the mixer is larger than the ones used in the frontend bandpass filter. The larger crystal allows a wider 'pull' range than the low profile ones, This pull range is still limited to around 1Khz max in the Rooster. Correcting the crystal to 3.560Mhz AND then allowing you to pull it a further 700-800Hz for the receiver offset is not possible therefore the circuit does not allow for adjust of the TX frequency but does give a reasonable amount of RIT control allowing stations operation around 500Hz either side of the QRP COA to be received with the correct offset. The TX frequency will be slightly (a few 100Hz) off the COA and typically we have found it to be approx. 3.5602 Mhz (200Hz higher than the COA). This should not cause any concern and is common in crystal controlled transceivers.

40m Note

The supplied crystal will allow operation within a 100Hz or so of the COA on 40m. I do have crystals that will put your transmission around 7.0293MHz which work great at avoiding all the madness on the COA and so result in a better QSO rate. Let me know if you want one for the mixer (the front end can remain the same for this small change)

30m Note

The 30m crystal was intended to operate on 10.116MHz but I find with the supplied crystal I can set the frequency anywhere between 10.116 and 10.118MHz, the offset at 10.116 isn't as great as I would have liked so if you want to be as close to the QRP COA as you can be, try 10.116 first and if your not happy with the offset set the frequency up a few 100Hz, around 10.117 is a good frequency as it still in the QRP area but also next to the FISTS CW Club frequency (which is 10.118MHz). The exact frequency isn't that important. I will assume you have set 10.116MHz for the rest of the instructions but use the frequency you have used in the following instructions below. Be aware that the further you set the frequency away from the marked frequency the lower the output power will be. At the extrema limit of 10.118MHz I find my own Rooster is down to 600-700mw of RF power, still a useful level if you really want to operate at that frequency.



20m Note

The 20m crystal should setup nicely on 14.060MHz, (can be set between 14.059 and 14.061MHz) the position of the RIT control has a little effect on the TX frequency (a little leakage of voltage to the varicap diode via the RIT switching transistor) this small change is only a few Hz so not a problem set the RIT control to the 3 O’Clock position when setting up the TX frequency

Back to the main testing (all bands)

Like all the tests so far, I would recommend a current limited power supply. Up to now you could expect a max current of 25mA, now you will need to set the limit up a little to 100mA as we have the driver stage installed and will be testing the transmit chain.

For this test you need another transceiver, antenna, dummy load (advisable), headphones and key.

Connect the remote transceiver up to a short (1m length) wire will do fine. Since at this stage we are listening for a very low-level oscillator signal it may be better to drape a wire from the transceiver’s antenna socket near to the Roosters PCB to be sure to hear its signal.

Monitor 3.560MHz on 80m, 7.030MHz on 40m, 10.116MHz on 30m version or 14.060MHz on 20m) on the remote set. Select a wide filter BUT be sure you put the radio in CW mode (Important!)

Connect the Rooster to the power supply with the key, antenna or even another short wire and connect the headphones and listen to the Rooster.

You should now hear at least band noise with the antenna connected. If anyone is operating around the Rooster’s freq you will most likely hear them too.

This is a direct conversion receiver, this means the internal oscillator runs at the frequency it is receiving, the side effect of this is that the oscillator’s signal can be heard on a receiver placed near it. If you can hear a tone on the remote rig don’t worry, that’s normal and not a fault. Now key the Rooster, you should expect the current to increase to about 60-80mA. Tune the remote radio to find the signal as you key, it maybe a few 100Hz off either direction.

On all versions BUT the 80m Rooster.

Once you have found it retune the remote radio to 7.030MHz (10.116MHz 30m/14.060MHz on 20m), or of course your selected frequency.

Now ideally with a ceramic trimmer (I use a small flat blade watchmakers screwdriver myself, with care !) adjust the trimmer on the Roosters PCB while holding down the key.



You should be able to bring the Rooster onto, or very close to 7.030MHz (10.116MHz 30m/14.060MHz 20m) on the remote radio.

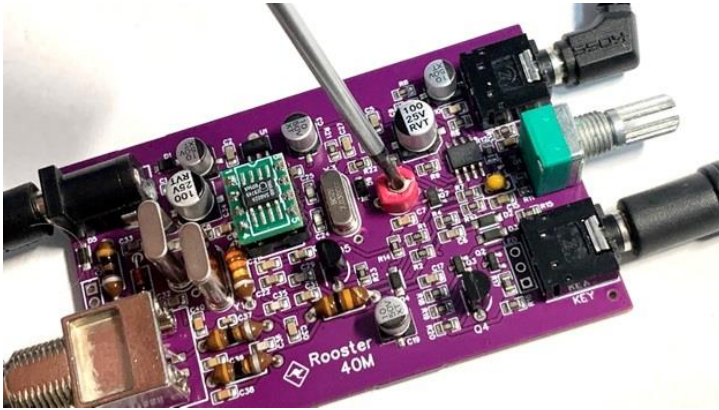

The tuning will move slightly when we fit the PA transistor later as the loading on the oscillator will change but for now this will be ok.

On all versions now.

Now connect the remote rig to a dummy load, no need for an antenna on the Rooster now, transmit a CW signal on the remote rig (set the power level as low as you can).

Set the RIT control about half way and the Rooster (on 20m about 3 O'Clock position). You should be hearing the transmitter, adjust the RIT control clockwise and the pitch should change, it should go very low as the control is almost fully clockwise, ideally a point should be heard when the tone stops altogether. This point is zero beat. Reset this control for your liking. The RIT control will have very little effect left of centre position as the adjustment is not linear.

Congratulations if this is all working, apart from the PA transistor and the RX/TX LED the Rooster PCB is complete. Again, unplug all the leads and move on.

Stage 11: Fitting the PA Transistor and rear panel.

IMPORTANT NOTE

The 80, 40 and 30m versions of the Rooster use a 2SC1162 transistor for the PA stage, if used in the 20m version the power level will be very low (around 250mW). The gain of this transistor falls off quickly at higher HF frequencies. Therefore in the 20m bandpack you will find a NEC 2SD882 transistor, this has much better gain at higher HF frequencies and so use that transistor on the 20m version, this should give you around 1 watt, maybe a little more.

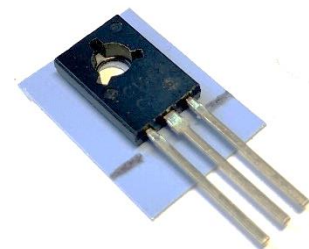



First find the heatsink mounting pad. It should be noted that this type of transistor (TO-18 case) does **NOT** need a mounting bush, if you have one it will not fit! BUT it **does** still need an insulator pad so make sure you use it,

Cut about 3 or 4mm off the bottom of the pad. I also trim a little off each side too, don't go mad doing that! Before you fit the pad put a small amount of clear tape on the top edge of the pad, use that to hold it in place. Put the pad on the inside of the rear panel so the mounting hole in the pad is in line with the mounting hole on the panel.

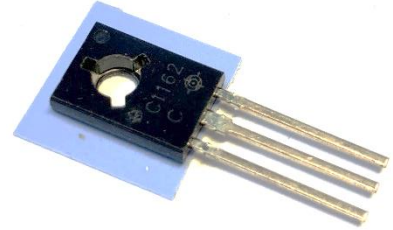

Now fit the rear panel on the back of the PCB, for now use the larger BNC nut and tighten the rear panel to the board.

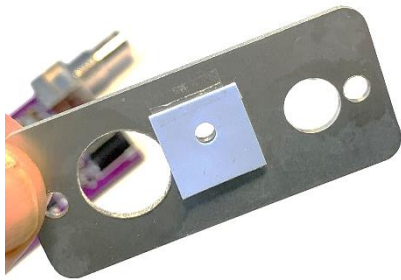

Only tighten finger tight for now, drop the transistor in place so **the metal side of the transistor is against the insulator pad**, The transistors leads have a slightly wider waist about 2mm down from the body. Push the transistor down lightly so that it sits at this position on the board.

Pass the M3 Black bolt through the rear panel and through the hole in the transistors body and use the M3 nut to attach the transistor. Do not fully tighten the nut yet.

Align the rear panel so the DC connector is in the centre of the power hole in the rear panel, carefully solder the centre pin of the PA transistor and recheck the correct fitting of the panel, resolder that transistor pin if you need to make adjustments. Once happy solder the remaining two pins of the transistor and trim the leads. Tighten the BNC and the transistor screw.



A good test to do is to check that the transistor is insulated from the rear panel, your panel is made from solid aluminium not fibreglass sheet like the front panel, this is to allow it to act as a heatsink.

The centre pin of the transistor is the collector, this is connected to the metal plate on the rear of the transistor. Check that the centre Pin of the transistor is NOT connected to the Roosters rear panel with a continuity meter check. If it is undo the mounting screw and check the insulating sheet under the transistor is not damaged and then re-assemble and check again.



Stage 12: TX/RX LED

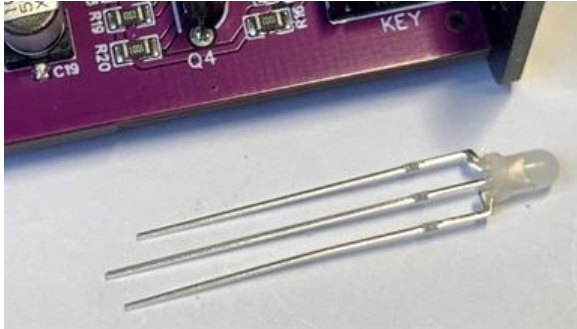

The Rooster has a LED indicator for RX and TX, we have used a dual colour LED so on RX it is Green and on TX its Red.

This LED has three legs, each one is a different length.

When we fit this part, the shortest leg **MUST** be towards the centre of the board.

You need to bend the legs at approx. 13mm from the back edge of the LED's body. You want to produce a 90-degree bend. I use a pair of pliers to hold the 3 legs and make the bend. You must make sure that you bend it the right way so that when fitted the shortest leg is towards the centre of the board.

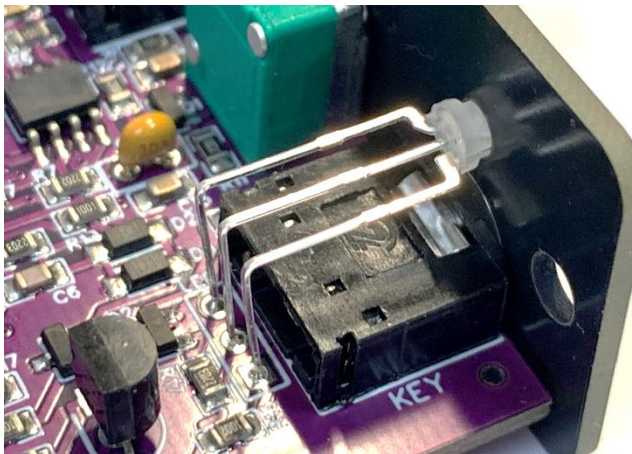

Temporarily attach the front panel loosely to the board using the RIT controls nut. Put the LED in the board (again checking the shortest pin is towards the board's centre). Then make sure the led passes through its hole in the panel. Now you have it at the correct height solder its legs and after double checking all is correct trim the leads flush. Now remove the front panel.

Stage 13: Tidy up the PCB

Now fit the front panel to the case loosely using two black M3 screws. Check the panel is correctly aligned on the case. Do not fully tighten the panel just yet.

Now before you put the board into the case a **VERY IMPORTANT** job.

Trim all the leads on the back of the board as flush as you can, there is not much clearance in the case, the 2 large lugs on the BNC are as low as you can go, make sure **ALL** other parts are cut flush and are shorter than these pins.

Now double check all the soldering. If you're happy you can Align the Rooster.



Stage 14: Alignment (Not needed on the 80m Version)

If you did the Alignment as suggested earlier this will be easy, it's just a final adjustment check.

The trimmer capacitor will allow you to correct the transmission frequency, you will need a receiver to do this (or a freq counter etc)

I put a ham band receiver on 40m 7.030MHz (or 10.116 for 30m/14.060 for 20m version) and in CW mode. I set the filter on the receiver, if it has one to around 500Hz. (again, use the frequency you have selected)

Now connect headphones/key and dummy load to the Rooster and once all these are connected then connect a power supply. If possible, a power supply of say 11v (don't go below 10.5v) will be kinder to the PA while doing the alignment.

Key the Rooster and you should get sidetone in headphones. You should find the Roosters signal on the receiver within a few 100's of Hertz of your selected frequency.

Set the receiver to your frequency and adjust the trimmer to bring the Rooster onto it if any adjustment is needed. You MAY not be able to bring the frequency bang on 7.030, (on 30m version 10.116MHz or 14.060MHz for 20m), you may only get within a 100 of Hertz of that target. That depends on the Crystal in such a simple circuit as the Rooster but remember 7.030MHz (10.116MHz) isn't a magical frequency, it's just the centre of operation for QRP users. Just get close to and don't worry. Don't leave the key down for more than a few secs at a time and give it a short break between transmissions to allow the PA to cool. Now unplug the power and leads.

Now you can drop the board into the case and the controls should pass through the holes in the front panel. You may have to 'jiggle' the front panel just a little to align it with the board. Secure the rear panel now with two black M3 screws and tighten the front panel screws.

Fix the RIT control with the supplied washer and nut, finger tight is all it needs. Turn the control fully anticlockwise and push the knob onto the shaft so the knob's marker line is pointing just before the start of the RIT marker scale. Do this lightly first and check it looks right when you turn it full travel both ways, when happy push the knob firmly down then fit the four stick on feet.

If you have a power meter connect that between the dummy load and the Rooster, check the output power. The lowest voltage the Rooster will work on is about 10.5v, the voltage regulator (it's a 8v device) will drop out around 10v as it needs about 2 volts head room. With approx 11v you will see over 1 watt, at about 12v nearly 2 watts, with a 13.8v supply you will most likely see a shade over 2 watts, again this will depend on a few factors but a variation of a few hundred milliwatts could be seen between units. This variation will only be 1dB or so and will not be noticeable to anyone receiving your signal. The 30m version will be a little lower in power too (around 1.5watts) and the 20m Version around 1 watt.

Current draw will be around 20mA on RX, and 400mA TX (@12v) (about 300mA on 20m)

Now connect the Rooster to an antenna (should be suitable for the band in use). If nothing else you will hear band noise.



Adjust the RIT to about the 3 O'clock position and call CQ, if called back adjust the RIT for best reception and enjoy the QSO. Note the RIT control does not change the TX frequency any significant amount (you may notice a few 10's of Hertz shift!) , just the receive frequency so you may find once set you don't need to change it.

Notes

All direct conversion type receivers can suffer from noise and other issues when used with a mains power supply. We recommend that the Rooster is powered by a battery pack. We have used and would recommend a 3-cell lithium-ion battery pack that gives just over 11v (mine is just over 12 when fully charged) . The Rooster still produces decent power output at this voltage and will operate for a very long time with such a power pack. A 7Amp/Hr 12v lead acid battery is also a good choice. It is always a good idea to put a fuse in the power lead. A rating between 1 and 2 amps should be fine. (30m/20m will need a little low rating , a 1 Amp fuse would be great for that.

Other band specific frequencies can be used by changing the Crystals, if you are only moving by a couple of KHz then you will be ok just changing the mixer crystal (Y1). If more then you will need to change all three crystals to the same frequency. (The mixer crystal should have a load capacitance of about 18-20pf if you decide to try your own crystals)

Something to be aware of with ALL direct conversion (DC) receivers will receiver on both sidebands at the same time, more or less equally well, that means that you may hear a station that sounds nice and strong but they do not answer your call, in this case they are most likely operation on a higher frequency than you but their second sideband is on the Roosters frequency. The Rooster uses a twin crystal filter in the front end that does help reduce this problem but it's a 'feature' of all DC receivers.

Audio Filter Response

The Rooster unlike many such simple transceivers, uses an active audio filter. This makes use of the spare op-amp in the dual op-amp used in the audio amplifier. This is centred around 700Hz and has a bandwidth of 500Hz.

The filter is certainly NOT a brickwall but does give a useful peak of about 12db to its centre frequency. Here is a waterfall showing the filters response. We used a Kanga RF Noise source module for the input to the transceiver and used a waterfall display to see the response.

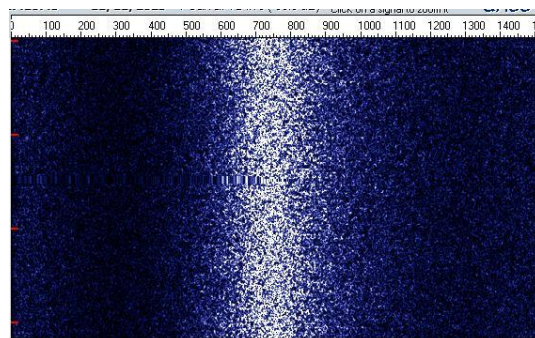

A word on PSU's, many PSU are poorly regulated and can cause hum and other problems. If you are using a PSU instead of a battery pack then try one that is well regulated and smooth. I also suggest making all the other connections to headphones, Antenna and Key BEFORE connecting (or turning on the PSU).



**KANGA
PRODUCTS**

The Rooster, as you would expect, has a LPF on its output. We have included 2nd and 3rd Harmonic traps too. Here is an example of the RF output spectrum on the 40m Rooster, this was supplied by one of the Beta builders at the RSGB Convention.

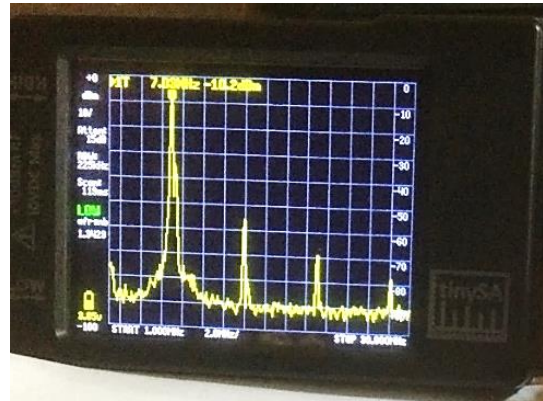
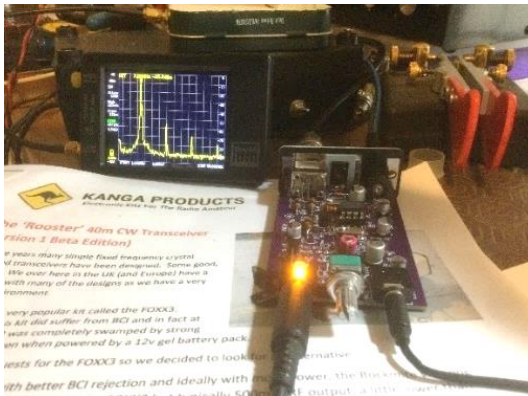

The 2nd harmonic is at about -46dB, the 3rd about -60dB

For those that are interested, the LPF design has been modelled using LTSpice, the graphs showing harmonic suppression are below.

We hope you enjoy building and using the Rooster.

Any questions or comments to sales@kanga-products.co.uk

Additional notes and possible mods

Not for the faint hearted.

Ok you can get a little more RIT range if you wish by completely removing the small variable trimmer. You will not be able to change the TX frequency as you did in the alignment section and without the trimmer the frequency will be a little higher than before, probably a few 100 hertz or more. But the RIT range will seem wider and hence more Sharp. Of course just because you can hear them doesn't mean they will hear you so not always a good idea I guess.

Any mods you do are completely at your own risk.



80m LTSpice

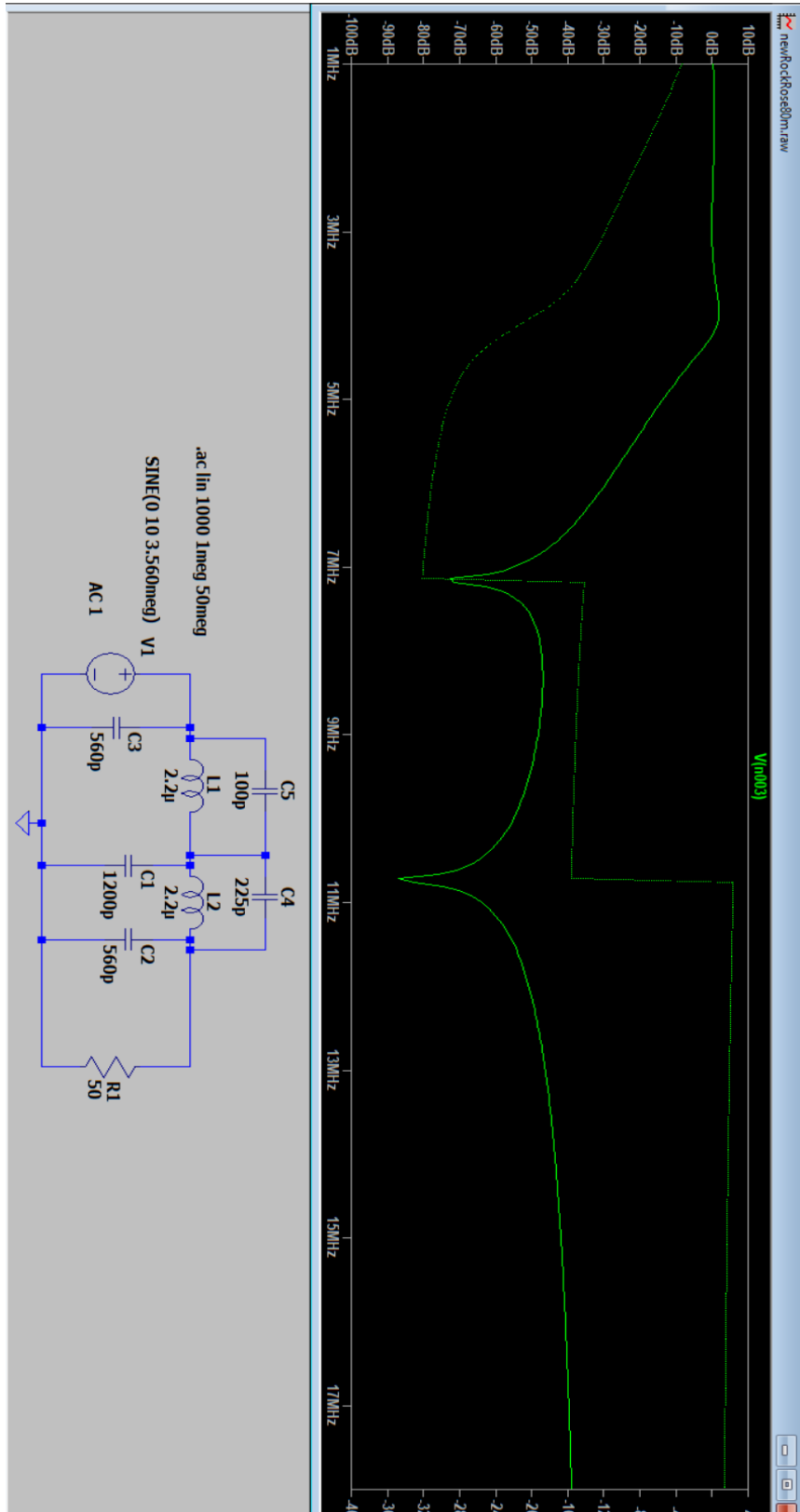



40m LTSpice

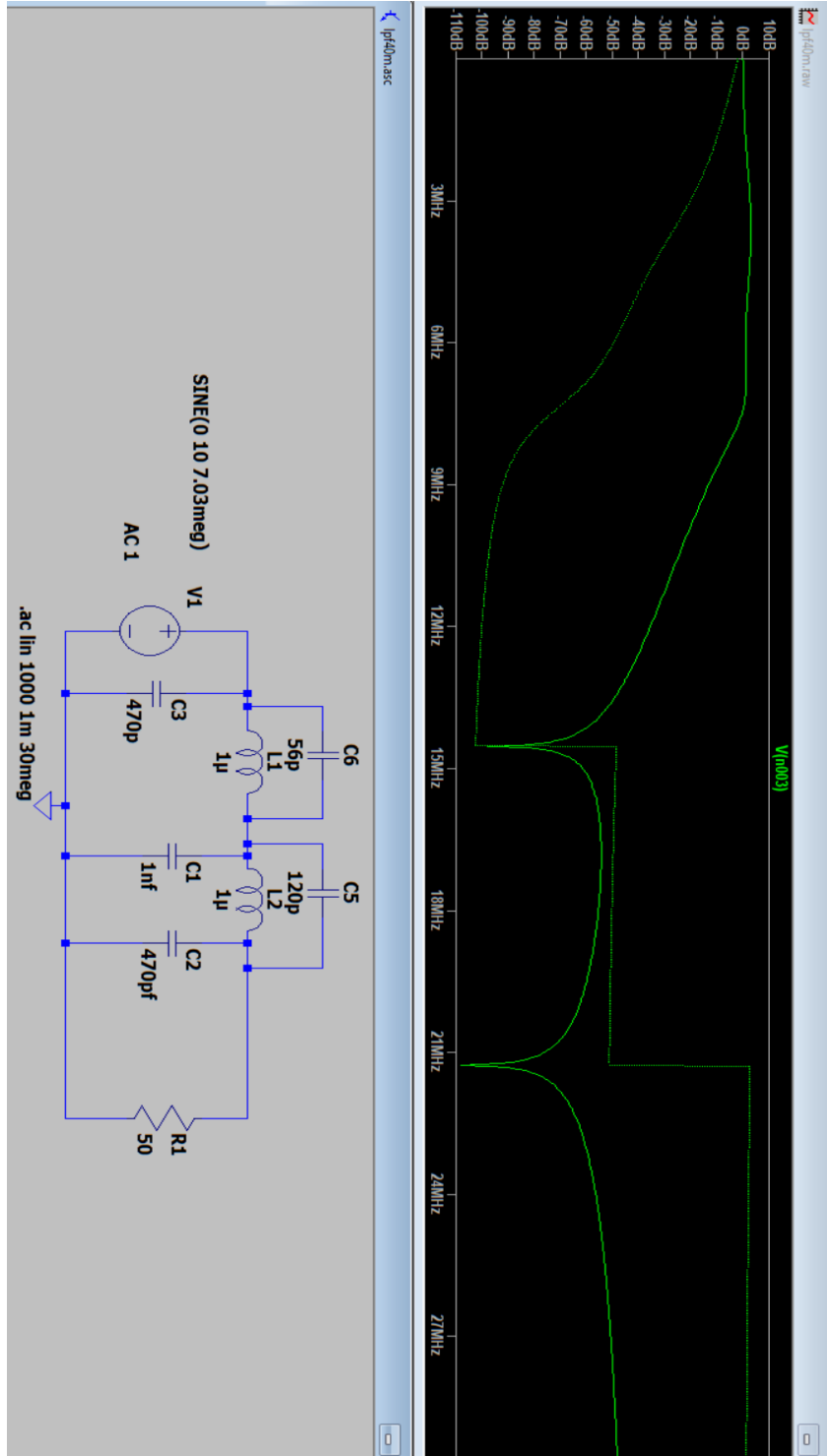



30m LTSpice

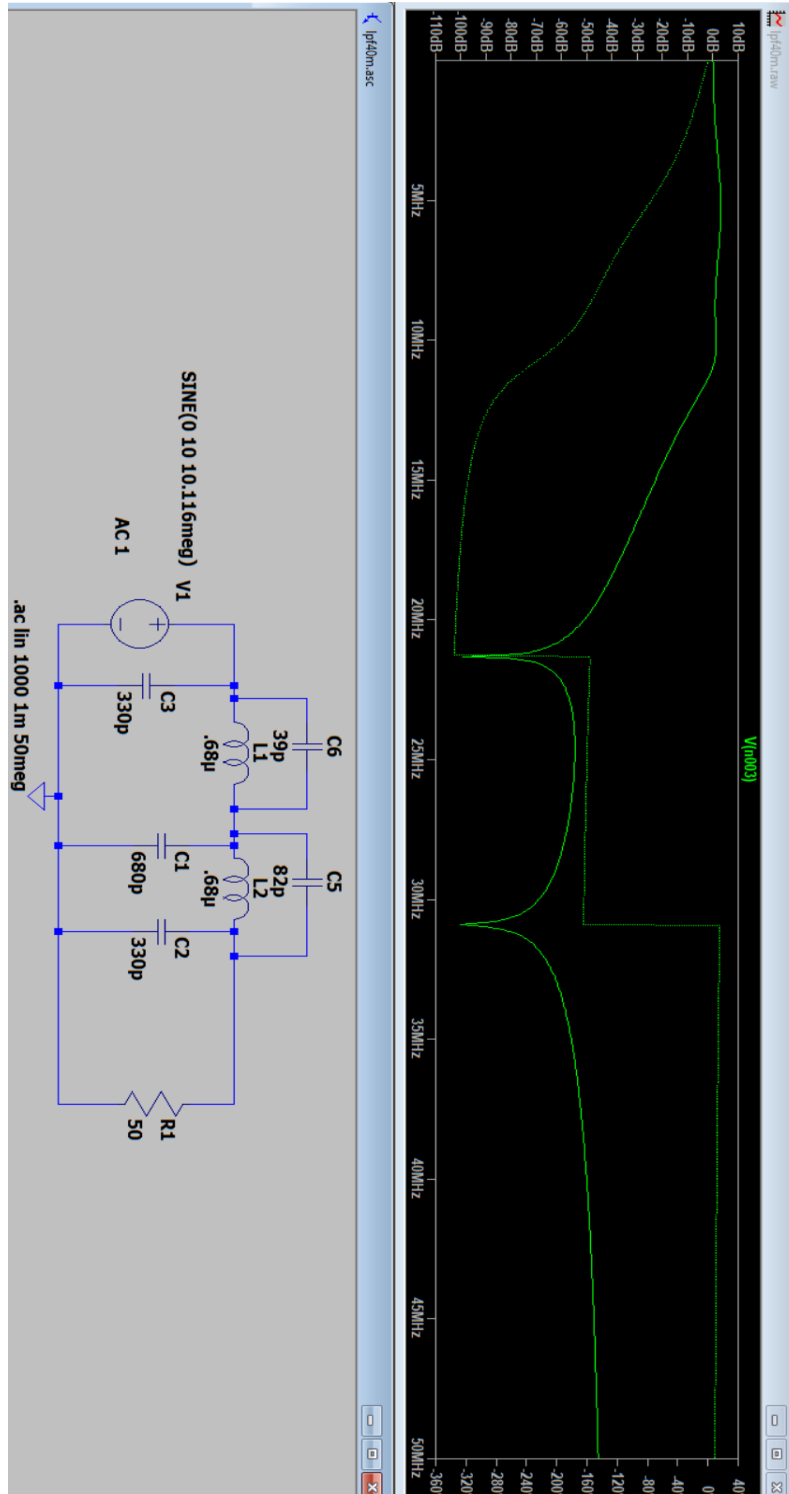



20m LTSpice

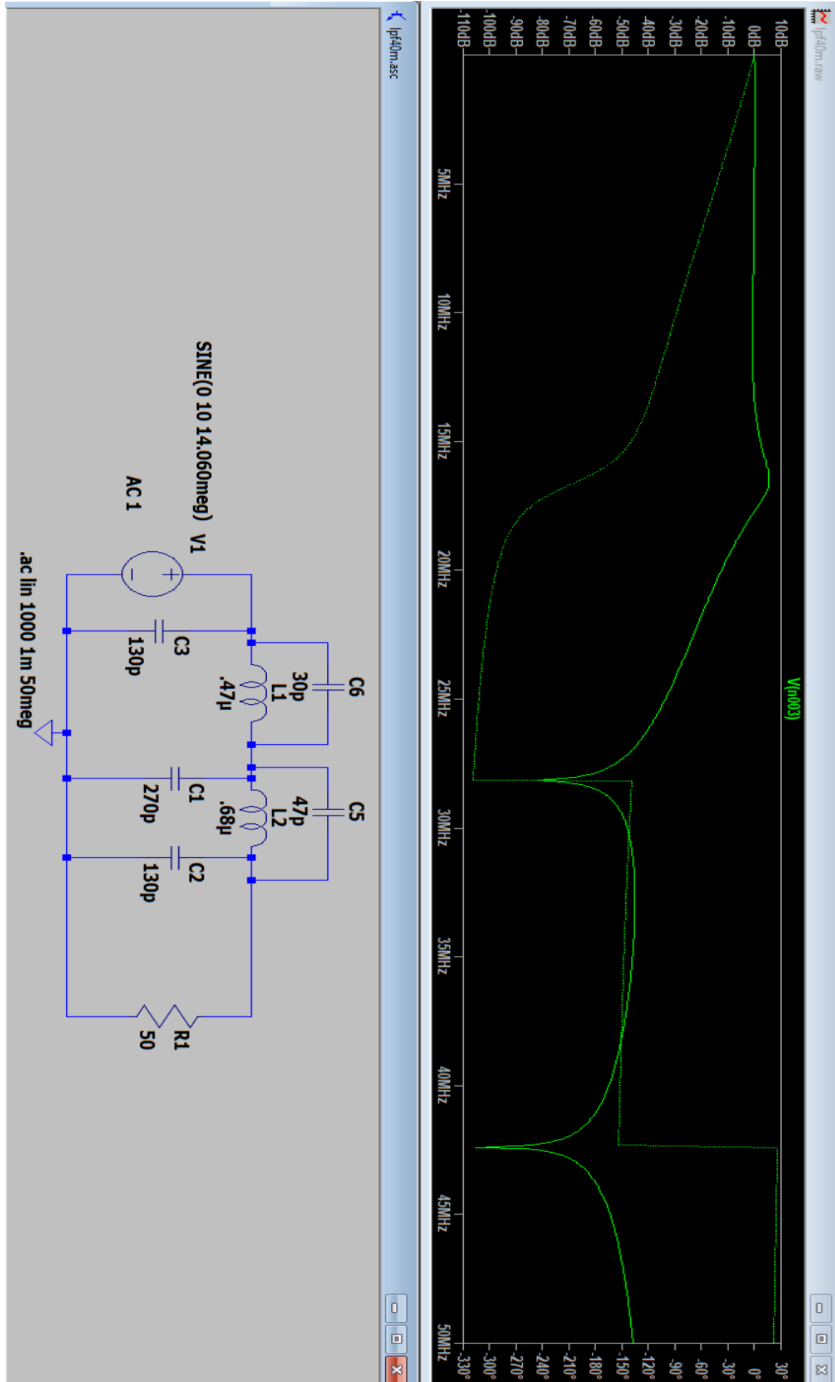



Circuit Diagrams (40m version values)

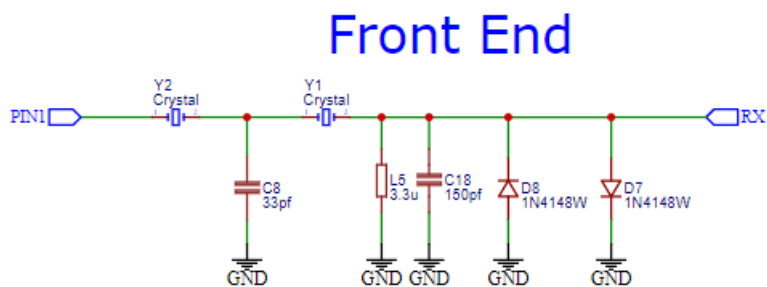
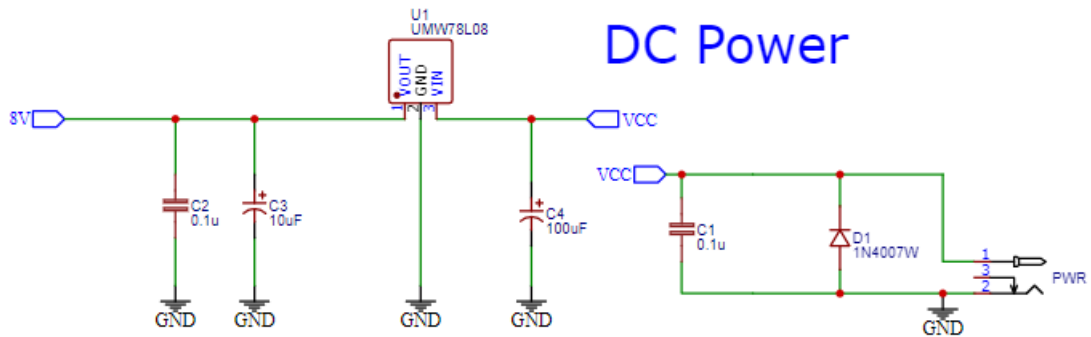



SideTone Circuit

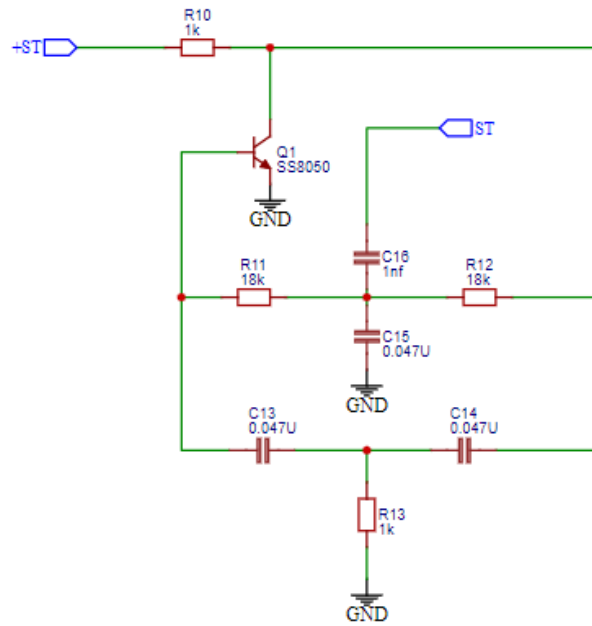

MIXER

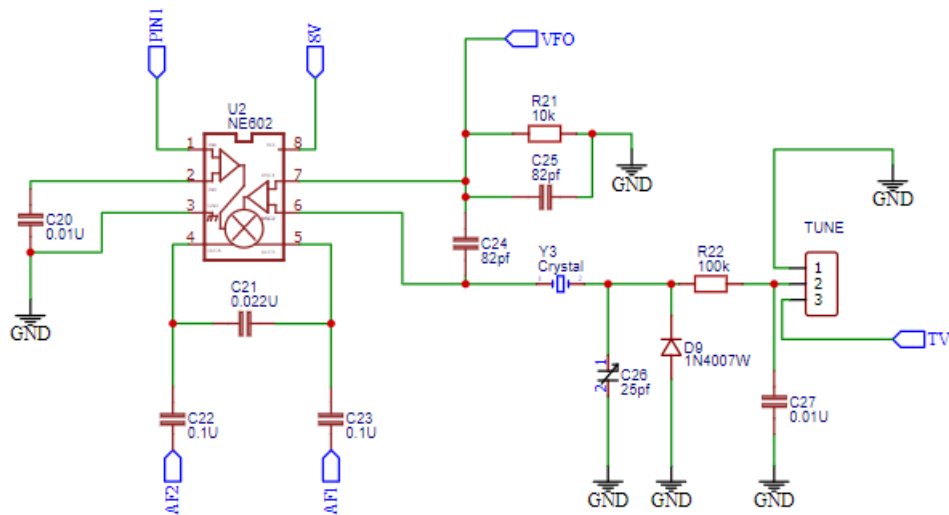

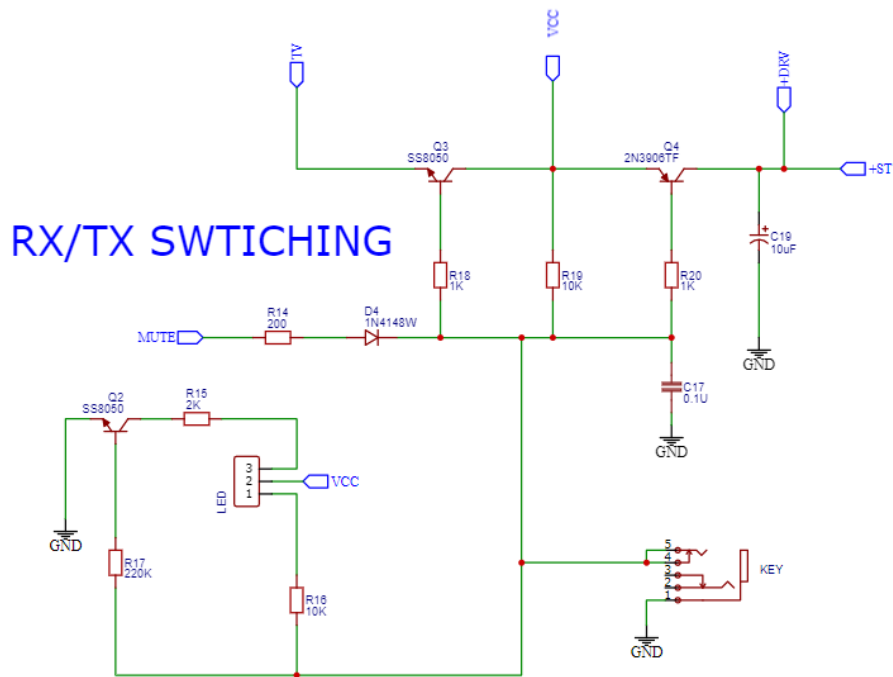
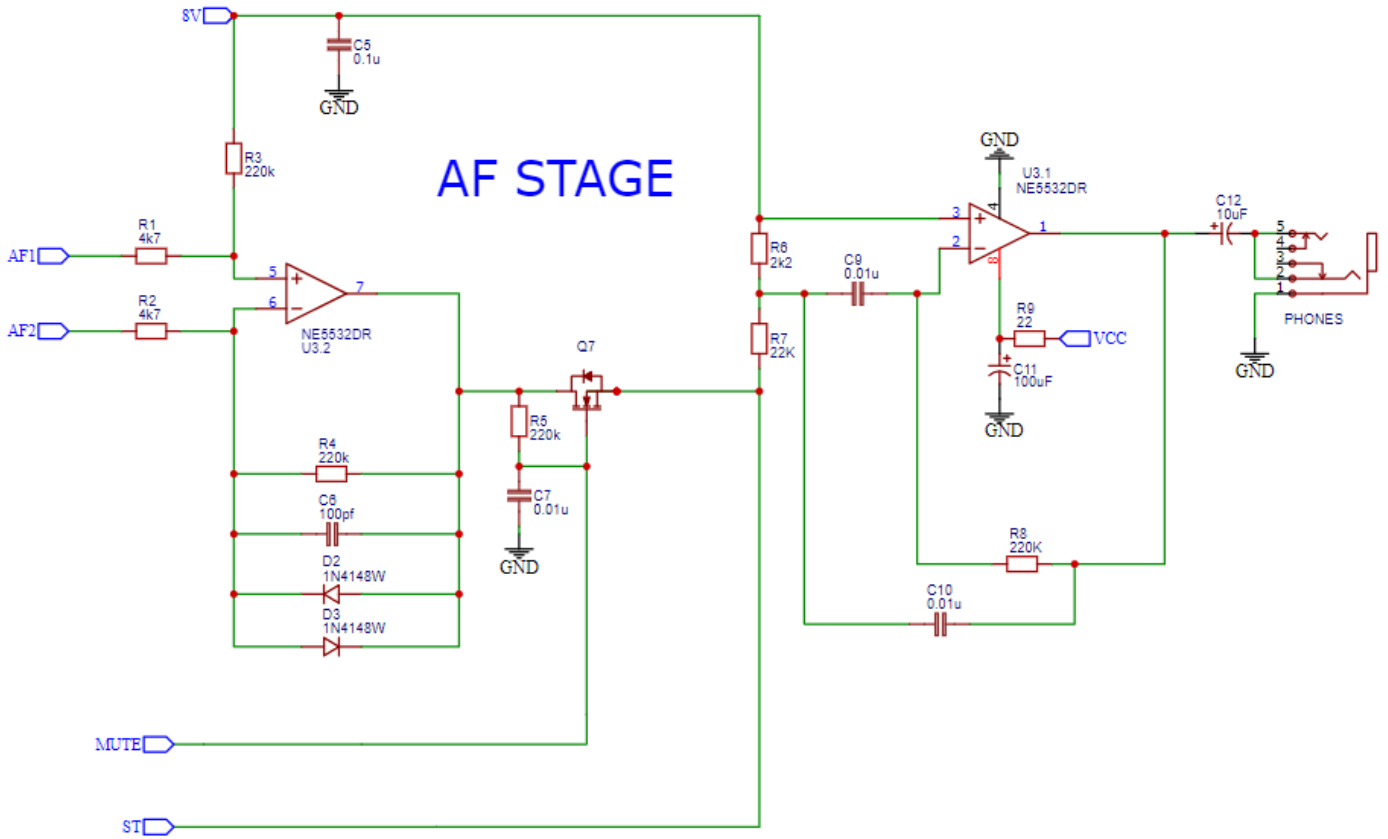



DRIVER/PA AND LPF (80m Version)

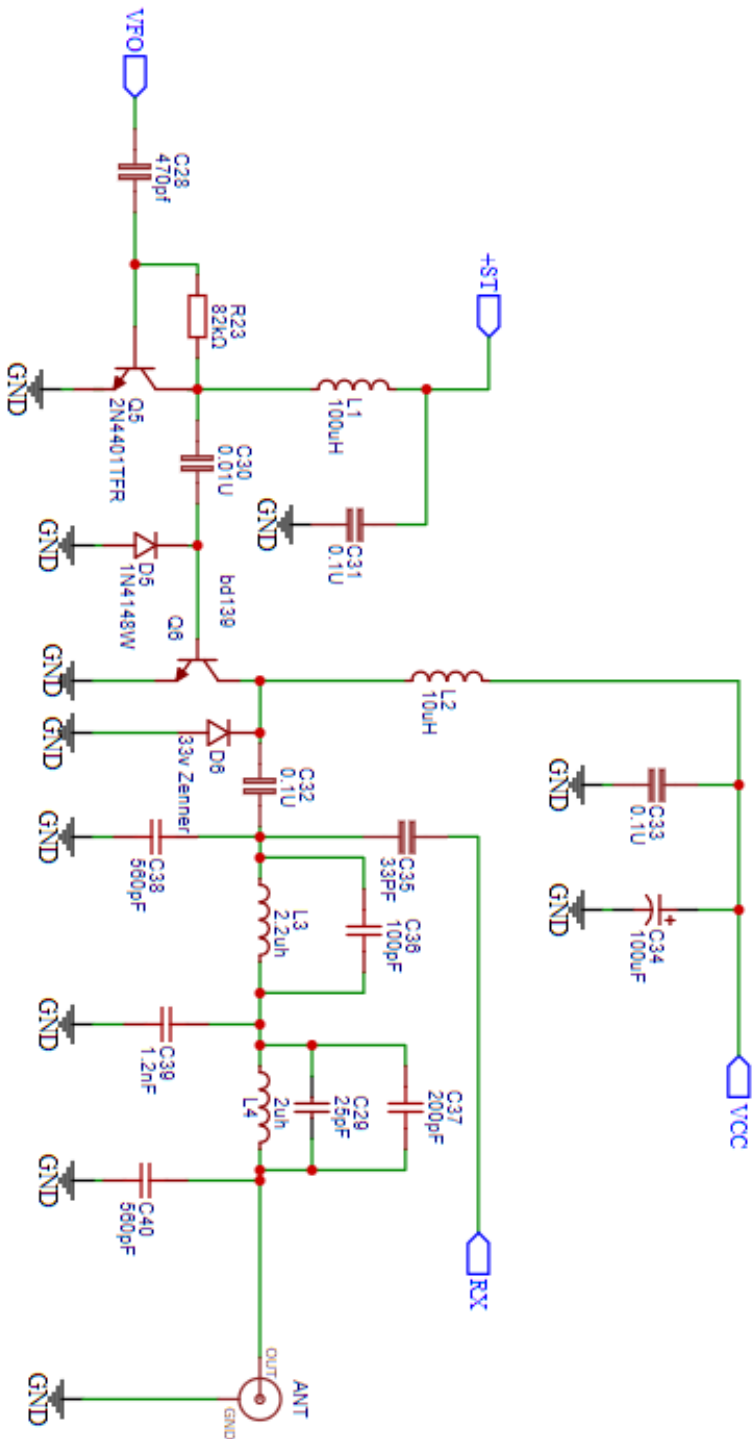



DRIVER/PA AND LPF (40m Version)

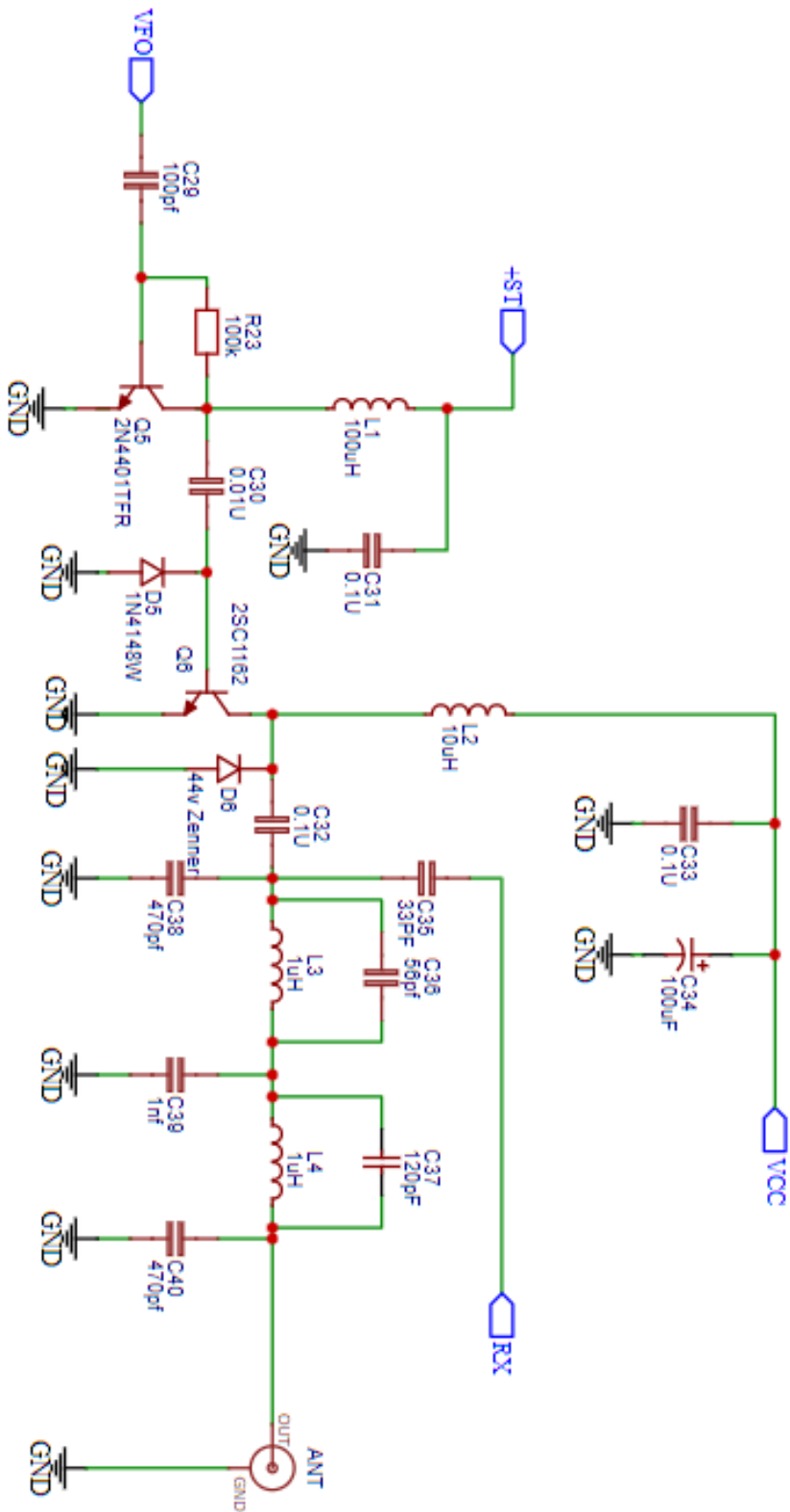



DRIVER/PA AND LPF (30m Version)

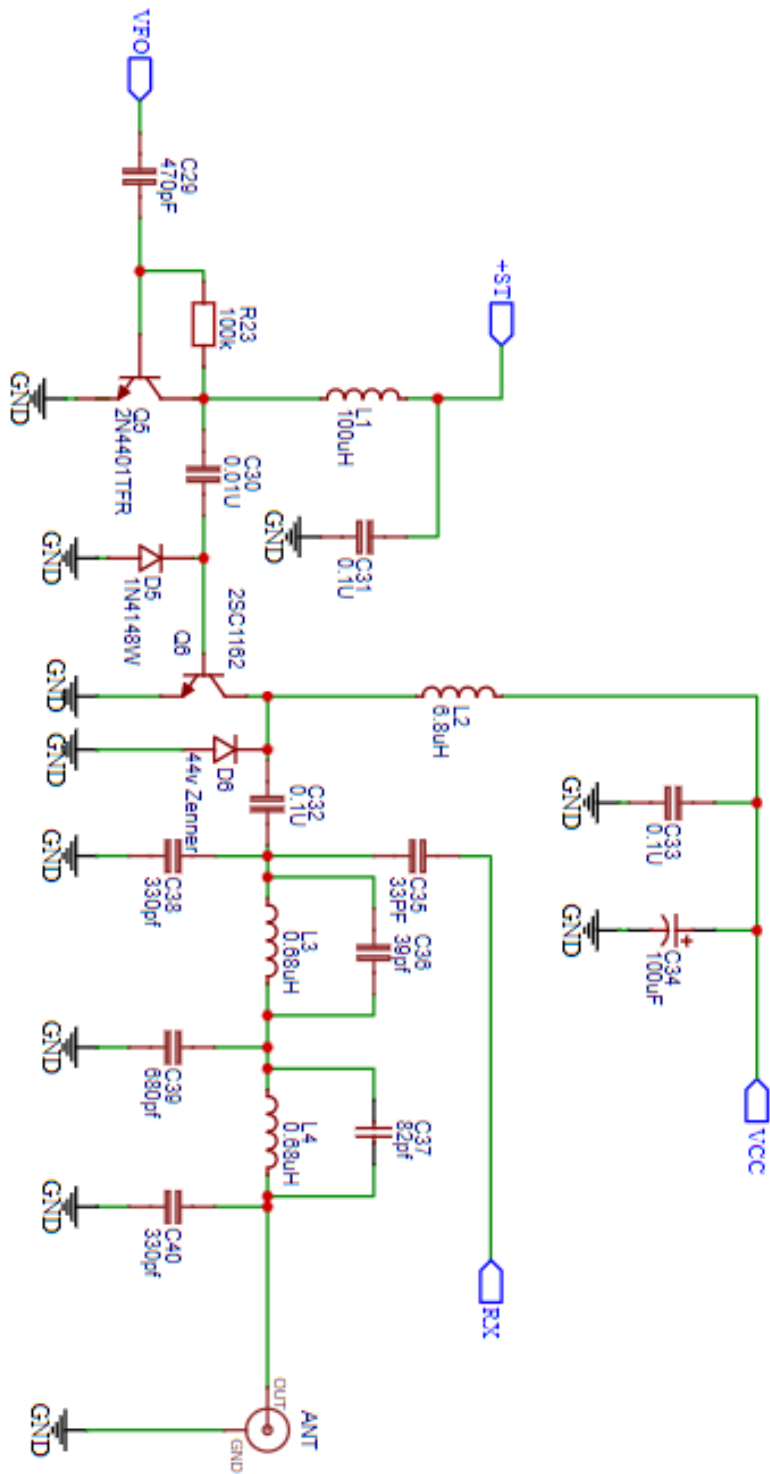



DRIVER/PA AND LPF (20m Version)

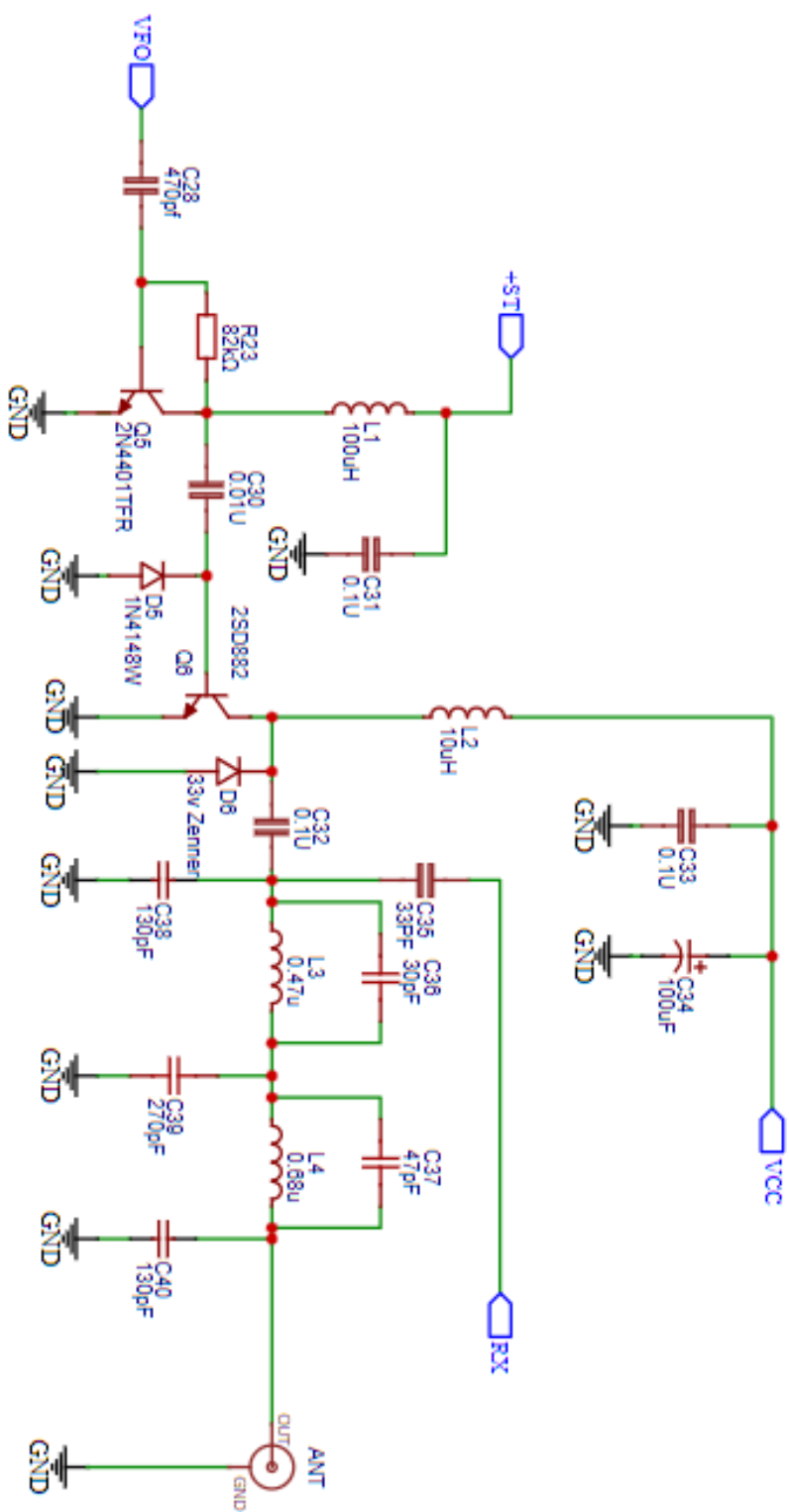



Board Layout (40m shown)

