

## INTRODUCTION:

Congratulations on your choice of the MFJ-9406 six-meter SSB Transceiver. Please read this manual carefully before attempting to operate your new radio. Let's begin with an introduction to some special features we think you'll like!

**Easy to Operate:** No microprocessor mumbo-jumbo. Just turn on and tune in!

**Potent Signal:** 10-Watt PEP--plus *Constant Current*<sup>TM</sup> syllabic speech processing for an added 4 to 6-dB advantage to cut through noise, fading, and QRM.

**Low Drain:** Mountain top on a D-cell NiCd pack--or operate at home with any 2-A AC supply. All-analog circuitry means highest energy efficiency.

**Hot Receiver:** 1.5-dB NF preamp and active-DBM front end dig deep into the noise to capture weak ones. If a signal is there, you'll hear it.

**Excellent Selectivity:** Sharp 2.3 KHz HF-style SSB ladder filter reduces passband noise, fights QRM, and improves intelligibility of a weak signals.

**TVI Protection:** Built-in 7-element lowpass filter knocks down TVI--lets you operate day or night, when *you* want to!

**Optional Semi-QSK CW Module:** Switch to USB-CW instantly--without changing modes, sidebands, or fiddling with the RIT. Just grab your key and start sending!

**Real S-Meter:** Steer your beam with pin-point accuracy--and give meaningful reports--with a full-sized analog S-meter. Also monitors speech processing level.

**Agile Tuning:** No tuning-rate shifts or stair-stepping! Reduction-drive analog VFO lets you scan for signals quickly, then zero in smoothly.

**Loud Audio:** Take your MFJ-9406 mobile. Powerful Phillips BTL-type audio IC and ruggedized 3-1/2" top-mounted speaker overcome ambient noise.

**Amplifier Jack:** Solid-state FET switch keys amplifiers such as Mirage A-1015-G.

**Built to Last:** Conservative design, premium G-10 plate-through pc board, quality components, handsome brushed-aluminum panel, and tough vinyl-clad case make for years of dependable service.

At home--or roving the countryside--you'll enjoy superb six-meter performance with your MFJ-9406. Best of all, it's fully backed by MFJ's exclusive *NO MATTER WHAT*<sup>TM</sup> one-year guarantee. If it breaks, we'll take care of it.

**General Description:**

The MFJ-9406 10-Watt PEP USB/CW transceiver is especially designed for fixed or portable radio communication in the six-meter amateur band. This unit operates from light-duty power sources such as NiCd battery packs or portable AC packs. Energy-efficient analog circuitry and syllabic RF speech processing deliver superior on-air performance while conserving valuable power. The MFJ-9406 uses a single-conversion mixing format and a heterodyne VFO for enhanced weak-signal performance. The transmitter features a built-in 7-element lowpass filter to reduce interference at TV and FM-broadcast entertainment frequencies. Other features include a sharp HF-communication grade crystal IF bandpass filter, built-in heavy-duty speaker, fully-analog mechanical S-meter, optional semi-break-in CW module, and intuitive "easy-to-operate" controls.

**Typical Specifications:**

## Receiver Section:

Frequency Coverage:	50.000-50.300 MHz
Receiver Type:	Single-conversion Superhet
Frequency Control:	Heterodyne VFO, low-side injection
IF Frequency:	10 MHz
IF Selectivity:	-6 dB @ 2.5 KHz
AGC:	Audio-derived, 70-dB dynamic range
Sensitivity:	.15 uV for 12-dB S/N
Audio:	1-Watt into 8 Ohms at 10% THD
Average Rx Current:	60-mA, (S-meter lamp disabled)

## Transmitter Section:

RF Power Output:	10-Watts PEP
VSWR Tolerance:	3:1 VSWR maximum
Peak Tx Current:	2.0 A
Speech Enhancement:	RF-compression, syllabic rate
Spurious Attenuation:	60-dB
CW Generation:	600-Hz tone (optional generator)
Mic Input:	600-Ohm dynamic

### Quick-start Operating Instructions:

- **Power Supply:** You may use any well-filtered 13.8-Volt, 2-Amp supply or 10 D-Cell NiCd pack to power your radio. The MFJ-9406 will also work with 12-Volt sources at reduced RF output. **Use a 5.5 OD x 2.1 mm coaxial power plug to connect your supply to the radio (Radio Shack 274-1569):** [+] lead goes to the center pin of the connector.
- **Microphone:** The MFJ-290 dynamic mobile microphone complements your radio's speech processor. RadioShack's 21-1172 replacement CB mic also plugs in without modification. To adapt other microphones, install a 5-pin DIN connector (RadioShack 274-003) as shown below. **Your PTT switch must cut both mic line and PPT line during receive (see below).**

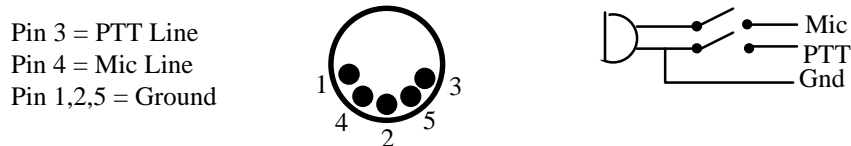

**Never use amplified mics with your MFJ-9406--they will overdrive the processor.**

- **Antenna:** The MFJ-9406 works well with any 50-Ohm six-meter antenna exhibiting a VSWR of 2:1 or less. **Avoid antennas with unknown or high VSWR.** Horizontal polarization is normally used for six-meter SSB in most parts of the U.S. Feed with low-loss 50-Ohm coaxial cable and use a short direct feedline to prevent loss. A simple dipole is adequate for local contacts, but a 3-5 element directional Yagi yields vastly superior long-distance performance.
- **Speech Processing:** The MFJ-9406 has a built-in syllabic speech processor. For best results, hold the mic about 1" from your lips and speak normally--the S-meter should deflect about 1/2 scale as you speak. When operating in noisy locations, you may reduce unwanted background noise by turning down the screwdrive-adjust mic gain control located on the radio's rear panel. Normal gain setting is 12:00.
- **Connecting a Power Amplifier:** Your radio has a built-in amplifier switch. This feature provides a ground path during transmit to key an external RF-power amplifier such as the Mirage A-1015-G or A-1030-G. To use this feature, connect a RCA-type patch cable from the **EXT AMP** jack on the back panel to your amplifier's key jack. Also, connect the appropriate RF patch cable from the MFJ-9406 **ANTENNA** jack to the amplifier's input jack. Be sure to follow all manufacturer's instructions and suggestions during installation. Amplifiers must be able to handle 10-Watts PEP of drive, and must be specifically designed for SSB (linear) service.

**MFJ-9406 Control Location and Function:**

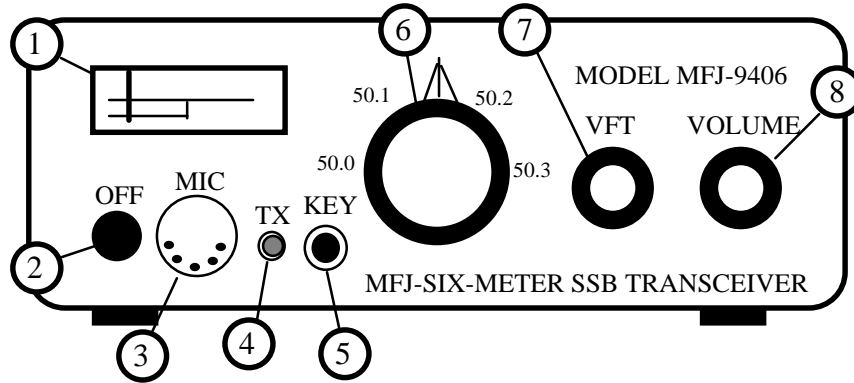

**FRONT PANEL**

- 1. S-METER:** Measures signal strength on receive, ALC on transmit
- 2. POWER SW:** Applies DC power to the radio.
- 3. MIC JACK:** Accepts 5-pin DIN connector for PTT microphone.
- 4. TX LED:** Illuminates when transmitter is keyed.
- 5. KEY JACK:** Accepts telegraph key--used with CW adapter module.
- 6. VFO TUNE:** Tunes in stations, indicates operating frequency.
- 7. VFT:** Fine tune control to assist with precise SSB tuning.
- 8. VOLUME:** Adjusts listening level.

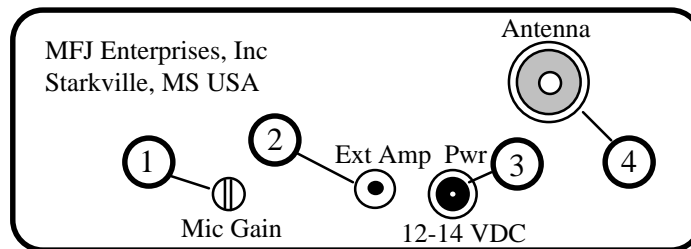

**REAR PANEL**

- 1. MIC GAIN:** Adjusts speech-amp gain (normal setting 12:00).
- 2. EXT AMP:** Keys linear amplifiers such as Mirage A-1015-G
- 3. POWER JACK:** 5.5mm OD, 2.1mm ID, [+] to center pin.
- 4. ANTENNA:** SO-239 for standard 50-Ohm coaxial plug.

### Six-meter Antenna Systems:

The better your antenna system works, the more you will enjoy using your MFJ-9406. Here are some tips for selecting and getting top performance from your antenna

- **Antenna:** Most six-meter SSB stations use horizontally-polarized Yagi antennas with 3 to 5 elements. These offer good gain, yet are small enough to mount on a standard TV rotor. Your operating style should influence the specific antenna you choose. For example, if you are a serious DX hunter, a long-boom 5-element Yagi or stacked array (two Yagis mounted one above the other) will deliver maximum directivity and superior weak-signal performance. However, if your operating interests are more general, a short-boom 3-element beam with a broad pattern and less front-to-back ratio may perform more satisfactorily for nets and roundtables. Whatever type of beam you select, be sure to tune it carefully for minimum VSWR. For getting started on six meters, we recommend the MFJ-1762 3-element Yagi. This is an especially light-weight short-boom six-meter antenna that provides a uniform pattern with approximately 6-dB forward gain.
- **Antenna Location:** Conventional VHF wisdom says you should mount your antenna as high as possible. However, be sure to factor in feedline loss. A chimney-mounted Yagi mounted in the clear at 40' and fed with 35' of low-loss cable may out-perform one mounted 20' higher on a tower and fed with a long lossy feedline. Choose the highest spot that provides a direct cable run. For best performance, isolate your antenna from other larger antennas and RF-reflective metallic surfaces.
- **Coax Cable:** For runs up to 60', RG-8X (RG-8 mini) works well at 50-MHz. However, for longer runs, spend the extra money for a high-quality low-loss cable like 9913 or RG213. Seal exterior connectors against moisture with silicon grease. For lowest loss, avoid using unessential in-line devices such as coax switches, tuners, and permanently-installed VSWR meters.
- **Rotor:** Almost any light-duty TV-type rotor will handle a short-boom six-meter beam. However, for long-boom Yagis or stacked arrays, use a heavier rotor especially designed for amateur radio antennas. This will provide more torque, faster turning, and stronger breaking power for large installations.
- **Safety:** Never install your antenna where it can accidentally fall and contact power lines or residential entrance cables. For lightning and protection, permanently ground the mast and coax shield *outside* the building using a good ground rod system. In addition, always disconnect the feedline from your radio at the first sign of threatening weather (even near-by lightning strikes can damage radio equipment connected to an antenna system).

## The Magic Band:

Six meters is a great band for every-day point-to-point local communication. However, six earned its reputation as "the magic band" because of the many exotic forms of skip that support long-distance communication. Here are some of the propagation modes you'll encounter as you operate this band:

- **Tropospheric Bending:** The signal path bends to follow the curvature of the Earth--usually due to a strong thermal barrier between air masses. Tropo openings are most common in hot weather--just after sunrise or sunset--when accelerated atmospheric heating or cooling takes place. Tropo-scatter, a weaker and more sporadic form of skip, may occur at any time. Even the momentary atmospheric heating produced by a passing high-altitude jet may cause distant signals to jump briefly in strength.
- **Sporadic E and FAI:** Signals reflect from a cloud of ionized gas that forms 60-70 miles above the Earth in the E layer of the ionosphere. Best dates are late November to early January and mid-May through July. Best times are late morning or late afternoon into evening. Watch for pipeline openings into limited geographic areas. FAI (propagation via field-aligned irregularities) may occur as sporadic E dies out.
- **Meteor Scatter:** When a meteor hits the upper atmosphere and burns, signals reflect briefly from ionized gasses that trail behind. During a meteor shower, these signal "bursts" may blend together and allow two-way contact over great distances. Meteor-scatter QSOs often require several exchanges to complete due to the intermittent path.
- **Aurora:** Debris from solar flares may ionize the E layer, permitting medium-range communication. Auroral SSB signals, modulated by rapid shifts in the auroral curtain, have a distinctive watery or buzzy sound--however voice contacts are possible (unlike on two-meters). Occasionally, the E layer may saturate fully, making signals steady and strong. Swing your antenna North to work other stations via aurora.
- **F2 and TE:** Signals reflect from the ionosphere's F layer--100-300 miles up--producing "work-the-world-on-milliwatts" conditions that six-meter enthusiasts rave about! Most often occurring around sun-spot maximum, F2 and TE (transequatorial) openings frequently yield DX free-for-all unmatched on any other amateur band.

## Grid Locators:

Know your "grid-square" number when operating on VHF-SSB. Most operators use the ARRL grid-locator system to identify their location. A typical report might go: "you're 5-by-6 in Fox November 43". This means your Q5 signal is S-6 in grid FN43 (Southern NH). VHF operators collect grids like HF hams collect states and countries, and VHF awards are usually based upon the grid locator system. Many operators post a grid map and color in each new square they work.

## Theory of Operation:

**General:** The MFJ-9406 is a 10-Watt PEP SSB transceiver that tunes from 50.0-50.3 MHz. The radio's single-conversion format uses a 10-MHz IF and a heterodyne 40-MHz VFO for low phase noise and circuit simplicity. The MFJ-9406 is designed for fixed, portable, or mobile operation from light-weight power sources, and uses analog circuitry throughout for low power consumption.

**Receiver:** The receiver is a single-conversion super heterodyne using a 10-MHz IF and a 40-MHz low-side injection VFO. A four-pole bandpass filter pre selects incoming signals. Preamp Q1 boosts weak signals and establishes the front-end noise figure at approximately 1.5 dB. Active DBM U1 converts signals to the 10-MHz IF, where a six-crystal SSB ladder filter establishes a 2.3 KHz message-channel bandwidth. IF amplifier U2 is controlled by audio-derived AGC. Product detector U3 demodulates incoming SSB. Recovered audio is fed to preamp U4a, which drives AGC amp Q3/Q4 and AF-power amp U5 (switch Q2 sets the AGC time constant for TX and RX modes).

**Transmitter:** Mic-amp U4b drives balanced modulator U7. DSB from U7 is routed to the IF filter, where the unwanted sideband is removed. IF amp U2 then compresses the USB signal and routes it to transmit mixer U8 where it is mixed with 40-MHz LO for conversion to 50 MHz. This signal is amplified by RF-driver chain Q10-11. Tuned 4:1 interstage transformers T4-T6 provide passband selectivity and impedance matching functions. PA Q12 uses a ballasted common-emitter device operating in class AB. L-networks provide input and output matching, and a seven-element low-pass filter following the PA output matching network reduces harmonic and spur content. A RF detector tracks the amplitude of the speech waveform, providing feedback for the speech processor and PA protection from most high VSWR loads. Power output is ALC-limited at 8-10 Watts PEP. PTT switch Q9 drives T/R relay K1.

**Mixing VFO:** The 6-MHz signal from VFO mixer U6's tunable oscillator is combined with output from 34-MHz crystal oscillator Q6 to provide 40-MHz VFO injection. A two-section bandpass filter rejects LO bleed through and unwanted mixer products. FET follower Q7 provides level-corrected low-Z drive to mixers U1 and U8.

**Regulation and Protection:** Adjustable monolithic voltage regulator U9 provides 10.5 Volts for low-level stages, and regulator U10 supplies 5 Volts to the mixing VFO. A diode/fuse crowbar circuit protects the radio against accidental reverse-polarity damage.

**Amplifier Keying:** FET switch Q13 provides a ground-path closure for the purpose of keying an external 50-MHz linear amplifier in transmit mode.

**CW Adapter module (optional):** The MFJ-416 plug-in CW module provides semi-QSK activation of T/R relay K1, and introduces a keyed audio tone to balanced modulator U7.

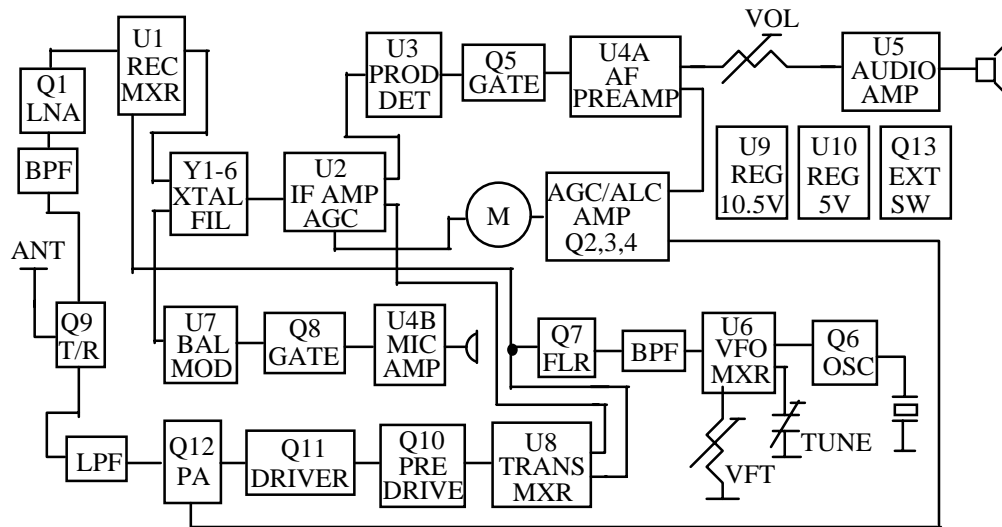
**Block Diagram, MFJ-9406 Six-meter SSB Transceiver:****MFJ-9406 Internal Adjustments: (see pictorial on page 9)**

- [1] **Voltage Regulator:** Adjust V-REG trimpot R78 for 10.5V on tab of U9 [18].
- [2] **RSSI Threshold:** Adjust AGC trimpot R11 for 4.3 V at RSSI test point [16].
- [3] **Meter Zero:** Adjust M-ZERO trimpot R17 for zero meter reading--no signal.
- [4] **IF Transformers:** Peak IF cans T1,T2 for maximum receiver sensitivity.
- [5] **RF Transformers:** Peak RF coils L1, L2 for maximum receiver sensitivity.
- [6] **BFO:** Set BFO trimcap C30 so close-in filter peak corresponds to 600 Hz beat note.\*
- [7] **VFO Cal:** Tune signal generator and VFO to 50.125 MHz, set L3 for zero beat.
- [8] **Mixing VFO:** Tune osc coil L5 and filter coils L6,L7 for maximum RX sensitivity.
- [9] **Carrier Balance:** *Carefully* adjust BAL trimpot R57 for minimum carrier\*\*
- [10] **Mic Gain:** Set for preference--12;00 position is factory default.
- [11] **PA Bias:** Attach 200-uA meter at [15], Set bias pot for 20-25 uA reading.

**Note:** To adjust [12-13], install a shorting plug at [14] to insert carrier. Also, turn ALC trimpot (R73) clockwise to disable ALC line (should be no meter deflection on TX).

- [12] **Exciter tune:** Key mic and peak C89, C96, C99 for maximum RF output.
- [13] **PA:** Key mic and peak C103, C110, C111 for maximum output--then remove plug.
- [14] **Carrier Insert:** Shorting plug location to insert carrier for tuning transmitter.
- [15] **IC Test Points:** Connect 200-uA meter here to set PA idle current (see above).
- [16] **RSSI Test Point:** Used when setting RSSI trimpot [2].
- [17] **ALC Level:** Key mic and speak, adjust ALC trimpot for 1/2-scale meter deflection.
- [18] **V-REG Test Point:** Set V-REG trimpot [1] for 10.5-V DC reading on regulator tab.

\*Caution--may unbalance carrier, step requires special skill and knowledge to perform.

\*\* If R57 alone does not produce deep null, interactively adjust R57 and T3 for best null.



**Pictorial Diagram -- Internal Adjustment Locations:**

**IMPORTANT WARNING:**

The tune-up information provided in this manual does not constitute a step-by-step guide for aligning the MFJ-9406. IF YOU LACK THE TEST EQUIPMENT, KNOWLEDGE, AND SKILLS TO ALIGN VHF SSB TRANSCEIVERS, **DO NOT** ATTEMPT TO MAKE THESE ADJUSTMENTS ON YOUR OWN !

It's far better to contact the MFJ factory for assistance. Mis-alignment may cause permanent damage to your unit, and may result in interference to other radio services in violation of FCC rule. MFJ cannot be held responsible for the performance of radios that have been improperly tampered with or mis-adjusted by owners and users.

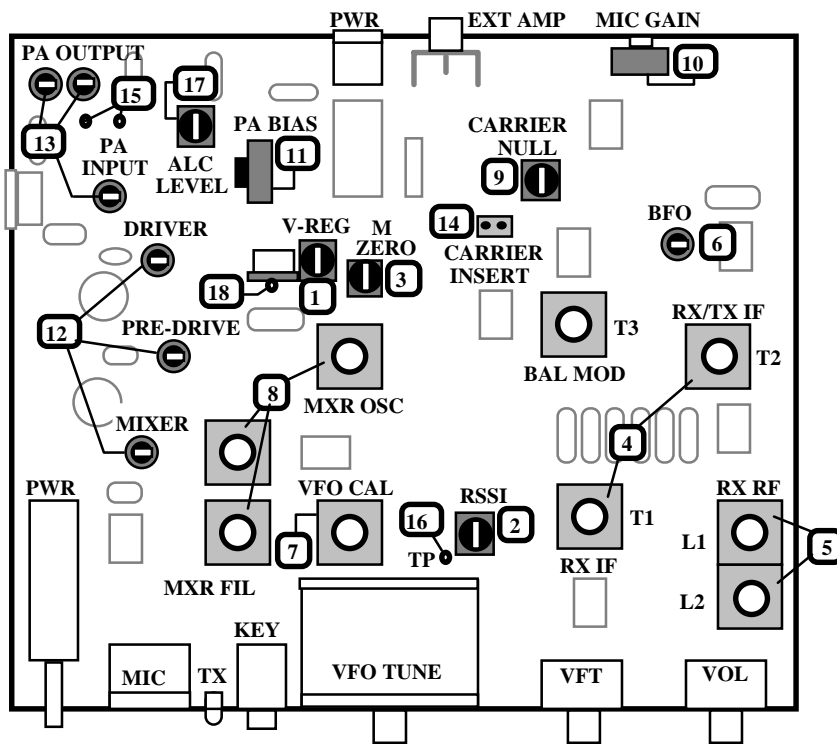

**Note:** For trimpots, trimcaps, and IF cans (T1-T3), use a non-conductive tuning wand with a metallic tip. For TOKO brand inductors, use a non-conductive wand with a narrow plastic tip. For Coilcraft brand inductors, use a small hex-head non-metallic tuning tool.

**ARRL Grid Locator Map**

**Trouble Shooting:**

[ ] **No signals received:** Check antenna and feedline for breaks or shorts. If okay, you should hear a clearly-audible increase in background noise when the antenna is connected.

[ ] **Spurious signals received:** Look for interference from nearby computers, modems, TVs, cordless phones, or other devices that may emit 50-MHz signals.

[ ] **Erratic transmit:** Check antenna VSWR. Also, check battery or power supply voltage. If supply drops below 12V under load, the radio's regulator will drop out and operation will become erratic. Set voltage regulator pot R78 for 10.5-V output measured on the tab of regulator IC U9. If you operate exclusively from 12 batteries, you may reduce V-REG output to 10.0V for added regulator headroom.

[ ] **High meter deflection on transmit, low RF output:** ALC pot R11 may be set too high (or VSWR may be high). Adjust R11 for mid-scale deflection into a 50-Ohm load.

[ ] **Splatter, low meter deflection:** ALC pot R11 may be set too low (or there may be a feedline short). Adjust for mid-scale deflection when transmitting into a 50-Ohm load.

[ ] **S-meter does not return to zero:** Confirm that V-REG (R78) is set for 10.5V on tab of U9. Confirm that AGC threshold (R11) is set for 4.3V at RSSI test point (no signal). When both readings are set, adjust R17 for zero meter deflection.

[ ] **Poor carrier suppression:** Unplug mic and short pin 3 of mic jack to ground. This will key the radio with no mic connected. Monitoring signal on an external receiver, adjust R57 for minimum carrier output. If this adjustment does not bring carrier down to the level of "shot noise" generated by the transmitter, more alignment may be required.

[ ] **Low or distorted transmit audio:** Check to see if mic gain is set too low. Also, make sure you are using a 600-Ohm low-Z dynamic microphone.

[ ] **Excessive background noise on signal, hum:** Mic gain set too high for the ambient noise conditions. Also, is mic or radio next to a power transformer or electric motor?

### **Technical Assistance:**

If you have any problem with this unit first check the appropriate section of this manual. If the manual does not reference your problem or your problem is not solved by reading the manual, you may call *MFJ Technical Service* at **601-323-0549** or the *MFJ Factory* at **601-323-5869**. You will be best helped if you have your unit, manual and all information on your station handy so you can answer any questions the technicians may ask.

You can also send questions by mail to MFJ Enterprises, Inc., 300 Industrial Park Road, Starkville, MS 39759; by Facsimile (FAX) to 601-323-6551; or by email to [techinfo@mfjenterprises.com](mailto:techinfo@mfjenterprises.com). Send a complete description of your problem, an explanation of exactly how you are using your unit, and a complete description of your station.

Schematic  
goes  
here

**Notes:**

