

TEN-TEC

**OPERATOR'S
MANUAL**

**Century/21
Analog**

CONTENTS

SECTION	TITLE	PAGE
I	INTRODUCTION	1- 1
	CONDENSED OPERATING INSTRUCTIONS	1- 1
	SPECIFICATIONS	1- 2
II	DETAILED OPERATING INSTRUCTIONS	2- 1
	Rear Panel Connections	2- 1
	Front Panel Controls	2- 2
	Full Band Coverage	2- 3
	Operating Hints	2- 3
	An Important Message	2- 4
III	ALIGNMENT AND SERVICE	3- 1
	Disassembly	3- 1
	Pilot Lamp Replacement	3- 2
	Fuse Replacement	3- 2
	Century Chassis	3- 2
	CHASSIS WIRING DIAGRAM	3- 4
	FIGURE 1 TOP VIEW	3- 6
	FIGURE 2 BOTTOM VIEW	3- 7
	FRONT END 80359	3- 8
	AUDIO PRE-AMP 80356	3-10
	AUDIO POWER AMP 80357	3-12
	PTO 80278	3-14
	MIXER 80358	3-16
	LOW LEVEL DRIVER 80354	3-20
	FINAL AMPLIFIER 80361	3-22
	LOW PASS FILTER 80360	3-24
	CONTROL BOARD 80355	3-26
	POWER SUPPLY 80353	3-28
	WARRANTY AND SERVICE POLICY	Insert

SECTION I

INTRODUCTION

Century/21 is a versatile medium power cw transceiver employing the latest techniques in solid state technology. Unique balun type transformers couple each stage in the rf sections, insuring efficient energy transfer without the need for resonating or peaking controls on the front panel. Individual low pass output filters for each band and a Class C push-pull final amplifier reduce transmitted harmonic and TVI radiation to a low value.

As you become more familiar with the operation of your Century/21 you will value the built-in operating conveniences more and more. The broad-band circuitry completely eliminates transmitter tune-up when changing bands or moving within a band. An automatic fail-safe power supply protects the transmitter from accidental antenna short circuit or operator error. The instant break-in feature, which allows incoming signals to be heard between transmitted characters, is a luxury enjoyed by only a few cw operators, but desired by all. It changes cw contacts from a series of monologues into conversation.

The receiving section is designed around a unique Double Direct Conversion circuit with performance comparable to the conventional superheterodyne. This approach provides frequency stability and bandsread characteristics which are the same for all bands. The ZERO BEAT feature allows precise setting of the transmitter frequency to the incoming station, and a three position SELECTIVITY control effectively separates closely spaced stations. All in all, the CENTURY/21 is designed for pleasurable cw operation for the beginner and old timer alike.

CONDENSED OPERATING INSTRUCTIONS

The following instructions will enable the operator to place the Century/21 quickly into operation. For a more detailed description of the controls and their functions, refer to SECTION II.

REAR APRON CONTROLS

POWER - Connect line cord to a source of 105-125 VAC, 50-60 Hz.

ANTENNA - Connect a 50 to 75 ohm, unbalanced resonant antenna, such as a beam, dipole or vertical. Balanced, long wire and similar antennas with higher input impedances should be used with an antenna tuner to provide a reasonable match (SWR) to 50 ohms.

KEY - Connect a straight key, bug or electronic keyer to this jack. Electronic keyers preferably should have a reed relay or a positive voltage, low saturation transistor output circuit, such as is employed in the TEN-TEC Model 670 Century Keyer.

GND - To reduce the possibility of stray rf pickup on interconnecting cables, which may cause parasitic oscillation, all station equipment should be well grounded to earth. This also reduces possibility of electrical shock, and provides some lightning protection. Connect a short, heavy lead, preferably shield braid, between chassis lug on the rear panel and a good earth ground.

FRONT PANEL CONTROLS

INITIAL CONTROL SETTINGS

- 1.) Select desired band with BAND switch. If working the 21 or 28 MHz bands, the accessory crystals must be installed. See instructions furnished with these crystals for proper installation.
- 2.) Tune dial to desired frequency within selected band.

- 3.) Set DRIVE control fully counter-clockwise (CCW).
- 4.) Apply power by actuating POWER ON-OFF switch located on RF GAIN control. This is a push-pull switch. Pilot lamps should illuminate.
- 5.) Push SET DRIVE button and advance DRIVE control until power meter indicates 70 watts input power. Release button. Transceiver is now ready for operation.
- 6.) The power supply in the Century/21 is equipped with an automatic current limiting shutdown circuit. If DRIVE control is set too high, or if the antenna should suddenly become disconnected or shorted, excessive current drain will turn the unit off. To reset, make sure cause of the overload is corrected, turn down the DRIVE control and then cycle the POWER ON-OFF switch. Panel lights will come on and normal operation may be resumed.

SPECIFICATIONS

GENERAL

FREQUENCY COVERAGE - 3.5 to 4.0; 7.0 to 7.5; 14.0 to 14.5; 21.0 to 21.5; 28.0 to 28.5; 28.5 to 29.0 MHz. (Crystals not supplied for last three segments but available as accessories.)

VFO FREQUENCY STABILITY - Less than 20 Hz change per degree Fahrenheit, averaged over a 40° change from 70° to 110°, after 30 minute warmup. Less than 20 Hz change from 105 to 125 VAC line voltage.

TUNING RATE - Approximately 17 kHz per revolution of main tuning knob.

POWER REQUIREMENTS - 105-125 VAC, 50-60 Hz. 10 watts receive, 100 watts transmit.

SEMICONDUCTORS - 25 transistors, 26 diodes, 5 integrated circuits.

PC BOARDS - 4 plug-in types, 6 integral.

CONSTRUCTION - Rigid aluminum chassis and sub-panels. Aluminum case. Grey front panel, black textured vinyl cover.

DIMENSIONS - HWD 6-1/8" x 12-1/2" x 12"

WEIGHT - 15-1/2 lbs.

RECEIVER

SENSITIVITY - 1 uV or less for 10 dB S+N/N.

SELECTIVITY - Three position; 0.5, 1.0 and 2.5 kHz.

VFO FREQUENCY - 5.0 to 5.5 MHz. Double Direct Conversion.

ANTENNA INPUT - 50 ohms, unbalanced.

AUDIO OUTPUT - 1 watt @ 8 ohms, less than 2% harmonic distortion. Built-in speaker; PHONES jack.

OFFSET TUNING - Approximately ± 5 kHz, defeatable with ZERO BEAT switch.

TRANSMITTER

DC INPUT POWER - 70 watts.

RF OUTPUT POWER - 30-40 watts, typical.

OUTPUT IMPEDANCE - 50-75 ohms, unbalanced.

T/R SWITCHING - Full break-in cw with PIN diode switch.

CW SIDETONE - Internally generated; adjustable level.

METER - Indicates total dc power drawn from supply.

FRONT PANEL CONTROLS

Receiver RF GAIN; receiver AF GAIN; ZERO BEAT switch; SET DRIVE switch; DRIVE; OFFSET; BAND switch; SELECTIVITY switch, three position; Main tuning knob; POWER ON-OFF switch; PHONES jack.

REAR APRON CONNECTIONS

ANTENNA jack; XTAL CAL jack; AUX 12 VDC jacks (2); KEY jack; GND lug; line cord.

SECTION II

DETAILED OPERATING INSTRUCTIONS

REAR PANEL CONNECTIONS

ANTENNA

Any unbalanced antenna presenting 35 to 75 ohms impedance to the Century/21 will work satisfactorily. This represents a SWR of 1.5 to 1 or less. When using random length antennas or open wire feed systems, a matching network should be used to obtain an equivalent impedance.

An unbalanced antenna is one which has a feed point with one of the two terminals at ground potential. The transmission line in this case is usually of the co-axial type, with the outer shield connected to the ground potential terminal. Balanced antennas have both feed terminals above ground potential. These can be converted into an unbalanced feed configuration by either inserting a balun between the feed point and the transceiver (at antenna, transceiver or anywhere in transmission line), or an antenna tuner designed to accept balanced loads and unbalanced inputs. Further information on this subject is available from the many antenna handbooks.

GROUND

To reduce possibility of stray pickup on interconnecting cables, all station equipment should be well grounded to earth. This is especially important when using high impedance antennas and matching networks, where the rf voltage levels are necessarily high.

KEY

The key actuates a series of circuits on the CONTROL BOARD assembly that supplies operating voltages to various transmitter and receiver circuits. When the key is closed, the receiver is disabled and operating bias is applied to the transmitter. At the same time the antenna is electrically isolated from the receiver input. There is a short time delay in the audio muting circuit to eliminate clicks in the speaker when keying. It is not long enough to interfere with the full break-in feature of the Century/21. Sidetone volume is independent of the audio gain control and is adjusted with a printed circuit thumbwheel potentiometer, accessed through a hole in the bottom cover.

For proper operation, the key line requires a very low resistance path to chassis, with no appreciable voltage across it. Hence, electronic keyers with reed relays, or transistor switched circuits incorporating low saturation NPN transistors are recommended. Improper key line conditions may cause lower than rated power output, improper keying envelope and/or key clicks. TEN-TEC Model 670 Century Keyer is designed specifically for use with the Century/21.

AUX 12 VDC

These two jacks may be used to power external equipment such as an electronic keyer. They are connected to the +12 volt regulated supply in the Century/21 and hence will show as additional WATTS INPUT on the panel meter. The full six amperes can be drawn from these jacks, with full regulation, but any power taken from these jacks reduces that available for the transmitter. For every ampere drawn from the jacks, the actual input power to the final amplifier will be reduced by approximately 12 watts. (Model 670 keyer only requires a small fraction of an ampere.)

XTAL CAL

This socket is provided for use with Model 276 Crystal Calibrator. Refer to main schematic for pin connections.

FRONT PANEL CONTROLS

POWER ON-OFF

The POWER ON-OFF switch is located on the RF GAIN control. It is a push-pull type. In addition to the on-off function, it is used to reset the power supply when it shuts down from overload. To reset, simply re-cycle the switch, after removing the cause of the overload (usually DRIVE control set too high).

BAND SWITCH

The BAND switch selects the desired 500 kHz band of operation. The AUX position can be used with an optional crystal for additional coverage in the ten meter band.

MAIN TUNING

The main tuning knob simultaneously adjusts both receiver and transmitter frequency. The dial scale is marked in 5 kHz increments from 0 to 500 kHz, with the MHz markings for each band displayed. Clockwise rotation increases frequency on 14, 21 and 28 MHz bands and decreases frequency on 3.5 and 7 MHz, due to the mixing scheme used in the transceiver. Use the appropriate scale for the band in use.

OFFSET

The OFFSET control tunes the receiver independently of the transmitter by approximately \pm 5 kHz. This feature is useful when several stations are being worked in a round-table, and all are not exactly on the same frequency. The received stations can be zeroed in with the OFFSET control without upsetting the transmitter frequency. Also, it is very useful in working DX where the DX station is working stations slightly off his frequency.

Since a station can be received on either side of the zero beat position, an interfering station slightly removed from the desired one may be completely eliminated by tuning the OFFSET control to the opposite side of zero beat.

ZERO BEAT

Pushing the ZERO BEAT button in defeats the OFFSET control and allows the operator to set the transmitter exactly on the received station's frequency. This is accomplished by tuning the incoming signal to zero beat, i.e. to where the received tone goes down to inaudibility, while depressing the ZERO BEAT button. The signal should be heard on either side of this setting, rising in pitch as you proceed further away. Releasing the button, the signal can then be set for the most pleasing pitch with the OFFSET control.

SELECTIVITY

Three positions of selectivity are available:

- 2.5 kHz for ssb or general cw listening.
- 1.0 kHz for cw or ssb with QRM.
- 0.5 kHz for cw on crowded band.

RF GAIN

The RF GAIN control is a potentiometer in the receiver antenna line. It operates as an attenuator to reduce the susceptibility to overload in the presence of extremely strong signals.

AF GAIN

The AF GAIN controls the input level to the audio amplifier. It should be adjusted for a comfortable audio level in the speaker or headphones.

SET DRIVE

This push-button switch is in parallel with the key line and places the transceiver in the transmit mode. It is used while adjusting DRIVE control to the desired input power level of between 60 and 70 watts, as indicated on the panel meter.

DRIVE

The control sets the level of rf applied to the final amplifier. For full rated input, it is set to provide a meter reading between 65 and 70 watts. Increasing drive beyond this point will trip the electronic circuit breaker. It is possible, when the Century/21 is powered on while in the transmit mode and the drive control is set to 70 watts, that the turn-on transient current surge will trip the circuit breaker. Either turn DRIVE control down or make sure the transmitter is not keyed on before attempting to turn the Century/21 on.

FULL BAND COVERAGE

The Century/21 as shipped from the factory has crystals installed for operation on the 3.5, 7.0 and 14.0 MHz bands. Three additional crystals are available as accessories which allow coverage of 21.0 to 21.5 MHz (Model 271 Crystal), 28.0 to 28.5 MHz (Model 272 Crystal) and 28.5 to 29.0 MHz (Model 273 Crystal). To install these crystals, place unit upside down, remove bottom cover screws (6) and carefully lift cover off. Exercise caution so that leads going to speaker are not stressed. The crystals are inserted into the sockets provided on the mixer board. (Refer to Fig. II, Section III.) Crystals are marked with operating frequency and TEN-TEC part numbers as follows:

Model	Coverage, MHz	Frequency, MHz	Pt. No.
271	21.0 to 21.5	16.0	48025
272	28.0 to 28.5	23.0	48026
273	28.5 to 29.0	23.5	48027

OPERATING HINTS

1. The speaker is most effective when the CENTURY/21 is placed on a hard surface and the two front snap-up legs are extended. With legs down, adequate sound quality is still produced when the unit rests on a hard surface.
2. When setting up the station, provide adequate ventilation for the heat sinks on the Century. Do not confine unit to a small volume without forced ventilation to circulate cool air around the heat sink.
3. The CENTURY/21 may be operated as a QRPp transceiver simply by adjusting DRIVE control downward.
4. Sidetone level control is accessible through finger hole located in bottom plate.
5. The VFO oscillator in the CENTURY/21, like any LC tuned oscillator, is adversely affected by ac magnetic fields cutting the coil turns. The oscillator output is frequency modulated at the line frequency, causing a "dirty" cw note and/or poor SSB quality in both transmit and receive modes. When installing the CENTURY/21, locate any ac operated equipment which may generate magnetic fields, such as power supplies, electric clocks, keyers, rotator controls and other station accessories, as far as possible from it. Since the VFO is located front and center, the most common cause of FMing is from placing these accessories on top of the CENTURY/21. However, large power supplies may cause interference even when placed adjacent to the transceiver. A check of the purity of a received cw signal should be made at the time of installation.

Due to the possibility of high voltage transients being generated in the output rf amplifier during band switching, changing bands should not be done while transmitting power to the load. Either place the transceiver in the receive mode or be certain of a "key-up" condition. YOU RISK THE POSSIBILITY OF DESTROYING THE OUTPUT TRANSISTORS IF THIS PRECAUTION IS NOT OBSERVED.

7. Although improper antennas will not damage the CENTURY/21, we suggest an SWR below 2 to 1 be achieved for maximum performance. In cases where the antenna cannot be matched to a better SWR, and the power supply repeatedly shuts down due to over-current conditions, the CENTURY/21 can be operated at reduced input power by rotating the DRIVE control counterclockwise to a position where the supply does not trip out.

AN IMPORTANT MESSAGE TO ALL CENTURY/21 OWNERS

In order for you to attain top performance from your CENTURY/21 transceiver, we feel that you should be briefed on all new information that comes to us from the field regarding the installation and operation of these units. Also, especially in the case of new technology such as solid state no-tune rf amplifiers, misconceptions sometimes arise from incomplete knowledge which result in erroneous conclusions being drawn that the equipment is faulty, erratic or not performing to specifications. There are sufficient CENTURY/21's now in the field to indicate to us that there are several rather serious information gaps in these areas. It is the purpose of this letter to fill in these gaps so that you can knowledgeably approach and correct any apparently improper performance characteristics of the CENTURY/21.

The main field concern appears to be a matter of fundamental technical knowledge regarding SWR, efficiency and power supply overload protection.

Before presenting a detailed explanation regarding this information gap, a summary of ten points to be aware of when installing the CENTURY/21 is given below. The reasons and technical background for these observations are explained thoroughly in the paragraphs below.

Ten Points to Observe When Installing the CENTURY/21

1. The CENTURY/21 will give best performance when properly loaded.
2. Even though the output transistors are resistant to damage from improper loads, they will not operate satisfactorily under all load conditions.
3. The output transistor dissipation will increase if not properly loaded.
4. Reactive impedance components in the antenna are applied to the transistors and may cause parasitic oscillations.
5. A given SWR reading does not tell you anything about the reactive components and is not accurate unless the load is a pure resistance.
6. A given SWR indicates one of two possible impedances. Each acts differently on the transceiver performance.
7. The most efficient operating point is when the load is 50-75 ohms, resistive.
8. The meter is not an indication of output power, but the input power.

9. If the breaker repeatedly trips, it is an indication that the load is enough removed from optimum so as to cause high transistor dissipation.
10. It is possible for the power supply regulator to drop out of regulation just prior to its tripping the breaker. Under these conditions, hum modulation will appear on the transmitted signal. With proper load the CENTURY/21 current drain will be considerably below the tripping point, so no hum should appear when operating properly.

On the Matter of Performance Claims

Our literature makes the statement that the CENTURY/21 will not be damaged from off-resonance operation or when using the wrong antenna, or even with no antenna or one that is short circuited. Notice that we do not say that it will perform to specifications under these conditions, or that it may not go into parasitic oscillation. In order to meet our published specifications, the antenna impedance should be between 50 and 70 ohms. However, satisfactory operation may be attained in many cases with antennas giving as much as 3 to 1 SWR. It all depends on the nature of the impedance and how it relates to the ten points of observation listed above. In the technical discussion below, you will be given the symptoms to look out for which indicate that the antenna match needs improving.

Technical Facts of Life

Although vacuum tubes and transistors both can be made to amplify rf power, there are some fundamental differences in how this is accomplished. We are all familiar with vacuum tube principles, but not with those of transistors. A better understanding of what we can expect under various operating conditions will aid in recognizing correct or incorrect performance.

1. Broadband vs Resonant Tanks - Almost all tube circuits use resonant tanks in the plate circuit. The Century/21 uses a broadband system. In class C operation these two approaches act similarly without drive being applied. The idle current is zero, even with load impedance variations from open to short circuit.

However, with drive applied, the two act very differently. In the case of tubes, the dissipation within the tube depends on both the tuning of the tank and the load applied. If the tank is resonated, and the load is very light, the internal power dissipated is quite small, as indicated by the null which reduces plate current almost to the level with no drive. Out of resonance, the plate current and hence dissipation increases rapidly and may damage the tube from overheating. In resonance, as the load is increased, the null becomes more shallow at a higher plate current, as a result of the power being delivered to the load. As the tank is tuned to resonance, the load impedance, which is usually on the order of 50 ohms, is transformed to a relatively high impedance of several thousand ohms to match the plate circuit impedance. Small load reactive components--either capacitive or inductive--can usually be balanced out in the tank resonating function.

With transistors, drive applied and no load, there is no resonant high impedance to limit the collector current, and so power is poured into the circuit (much as the out-of-resonance tank conditions). Since there is no load power, all has to be dissipated in the transistor. So even with no load, the power supply circuit breaker may trip. The broad-band transformer system used with transistors transforms the 50 ohm load impedance not higher, but much lower (in order of 4 or 5 ohms) to match the transistor output impedance. Since this transformation is fixed in design, any reactive component in the load

impedance is applied in a transformed way to the collector circuit. Certain reactances at this point, especially inductive, give rise to parasitic oscillation. To correct for this, the antenna impedance should be changed to remove this reactance, or a matching network should be inserted between antenna and transceiver. It is important to remember that any antenna changes its impedance with frequency, so one that resonates well at one end of the band may well cause oscillations or trip the circuit breaker on the other end. If entire band operation is desired, especially on 80 and 40 meters, the adjustable matching network approach would be the better choice, rather than try to make the antenna behave over the entire band on a cut-and-try basis.

A final point to bring out regarding broadband vs tank systems is that there is a limit to the amount of current you can draw from an emitting filament and this saturation current will limit the amount of power drawn from the supply. In the case of transistors, where the collector internal impedance is only a fraction of an ohm, extremely high currents can be demanded of the power supply, especially with mismatched loads well below 50 ohms.

2. SWR - Two Kinds - The standing wave ratio is a direct measure of the ratio between two impedances, i.e. an SWR of 3 to 1 tells us that one impedance is three times the other. Therefore, the unknown impedance can be either three times as large or three times as small as the known one. If the desired impedance that the transceiver wants to see is 50 ohms, a SWR of 3 to 1 on the line may mean a load impedance of either 150 ohms or one of 17 ohms. If it is 150 ohms, the transmitter will act differently than if it is 17. In the first case, the power demanded from the supply will be much lower, and will not be large enough to trip the supply. In the second case, even though the SWR meter reads the same, the supply may repeatedly trip out. The SWR reading gives no indication of reactive components, nor can it separate the resistive from the reactive components. It is calibrated with a pure resistive load and therefore has its greatest accuracy with pure resistive loads. The SWR bridge only should be used as an indicator when attempting to adjust the antenna system to a pure 50 ohm resistive impedance.
3. Efficiency - Since transistor amplifiers have a very low value of output impedance, they act more or less as a constant voltage source. That is, the rf output voltage tends to remain at a fixed value regardless of the load impedance. Hence, the output power will vary depending on the value of load and increase as the load impedance goes down. It can be seen that a 3 to 1 SWR on the low side of 50 ohms will ask the amplifier to deliver much more power than a 3 to 1 SWR on the high side. Since the amplifier does have a finite value of output impedance, the amount of power delivered to the load with efficiency, will change with load. Unless the load is near the design value, the transistors will heat up unnecessarily without delivering any more power to the antenna.

If the above precautions are observed, we are sure that you will be more than delighted with the performance of your CENTURY/21.

Recommended Reading

1. ARRL Antenna Handbook
2. Antenna Handbook, Ken Glanzer, Cowan Publishing Co.
3. W8NWU Teeter Totter Tuners, Schultz, CQ Feb. '69. Page 27

SECTION III
ALIGNMENT AND SERVICE

This section is subdivided into descriptions of the main chassis and each plug-in assembly. Pin and transistor voltages are given for each unit. Readings should be within 15% of listed values when measured with a dc voltmeter with at least 20,000 ohms-per-volt impedance. All readings are dc and positive with respect to chassis GND unless stated otherwise. Plug-in pin locations are in the same relative positions on the assemblies as noted on the schematics. In other words, if the assembly is placed component side up on the schematic in the same position as shown in the photograph, the individual pin functions are the same as those noted on the schematic.

When removing a plug-in assembly, note the orientation of the board in the chassis so it can be replaced correctly. Some assemblies can be inadvertently inserted incorrectly if care is not taken. Figures 1 and 2 show correct placements.

To remove a plug-in assembly, first remove the screws holding the board to the sockets and any screws or nuts securing single socket boards. Then, with long nose pliers, work the assembly straight up out of the socket or sockets by pulling on the end pins in sequence.

To facilitate location of the various components that may require adjustment or alignment, refer to the table below.

<u>Function</u>	<u>Assembly</u>
Receiver i.f. Amplifier	Front End, 80359
Receiver r.f. Coils	Mixer, 80358
Offset Zero Adjust	Control Board, 80355
Sidetone Level	Audio Pre-Amp, 80356
Driver Bias Set	Final Amplifier, 80361
Meter Calibration	Power Supply, 80353
Power Supply Trip Adj.	Power Supply, 80353

NOTE: All VFO linearity and band edge calibration adjustments are contained in the PTO assembly 80278. This is described as a separate assembly for simplicity.

DISASSEMBLY

Removal of Top

Remove the upper two screws on each side. Lift the top off.

Removal of Bottom

Remove four screws holding speaker grille. Feed speaker down through cutout, using notches in cutout to clear outer edge of speaker. Remove the remaining six screws - two on bottom, two on each side.

Removal of Front Panel

First remove top and bottom. Remove BAND switch knob using a small flat-bladed screwdriver. Then remove the main tuning knob and SELECTIVITY knob using 4-40 Allen wrench provided. The remaining knobs pull straight off. It may be necessary to pry them off with a flat-bladed screwdriver. Protect the front panel from scratches using a piece of cloth or cardboard under the driver. Remove the PHONES jack using a 1/2-inch wrench. Unsolder the wires to the ZERO BEAT, SET DRIVE and METER. Note and record polarity on meter leads. Using a 1/2-inch socket, remove the four control nuts from the OFFSET, DRIVE, RF GAIN and AF GAIN controls. Pull the panel forward and remove.

PILOT LAMP REPLACEMENT

The panel lights are all 14 volt, bayonet type, No. 1813 or 1892. Access to these bulbs is by removing top of unit.

FUSE REPLACEMENT

The fuse is located inside the bottom. Replace with a 2A SLO-BLO.

CENTURY CHASSIS

The chassis wiring is color coded.

Color	Function	Voltage	
		TRANSMIT	RECEIVE
Black	Ground	0	0
Brown	OT POT	0	2.5
Red	+12	12.5	12.5
Orange	OT ON-OFF	12.5	0
Yellow	OT POT	0	4.3
Green	OT POT	3.0	5.8
Blue	T	10.5	0
Violet	DRIVE	*	0
Gray	METER	-1	0
White	+9 reg.	8.9	8.9
Brown-White	SIDETONE	0	0
Red-White	KEY	0	4.5
Orange-White	OT	3.8	#
Yellow-White	XTAL Cal.	0	0
Green-White	+23v	18*	23.0
Blue-White	R	0	11.0
Gray-White	BASE Q1	13.2	13.2

*Depends on DRIVE setting

#Depends on OFFSET setting

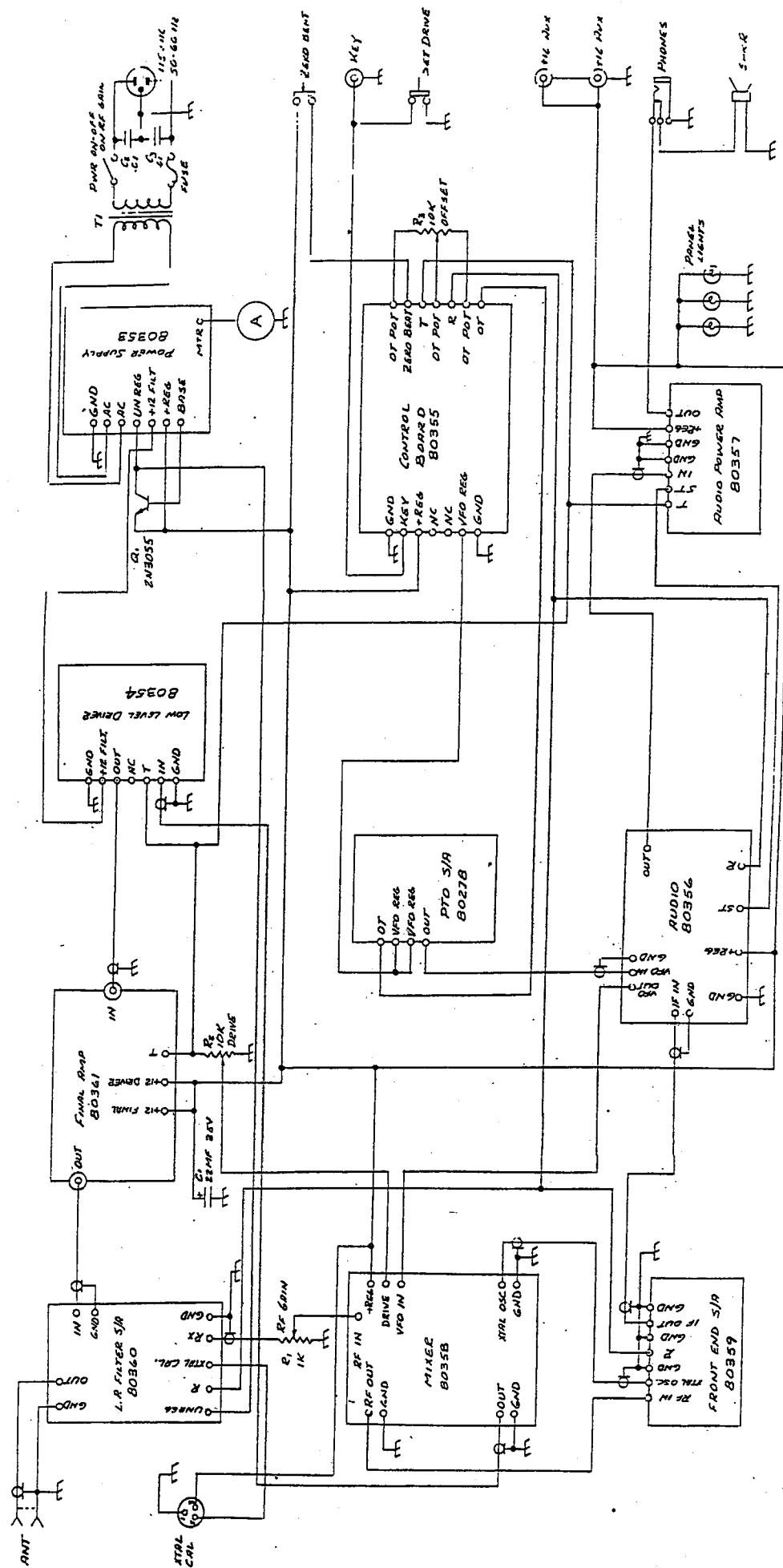

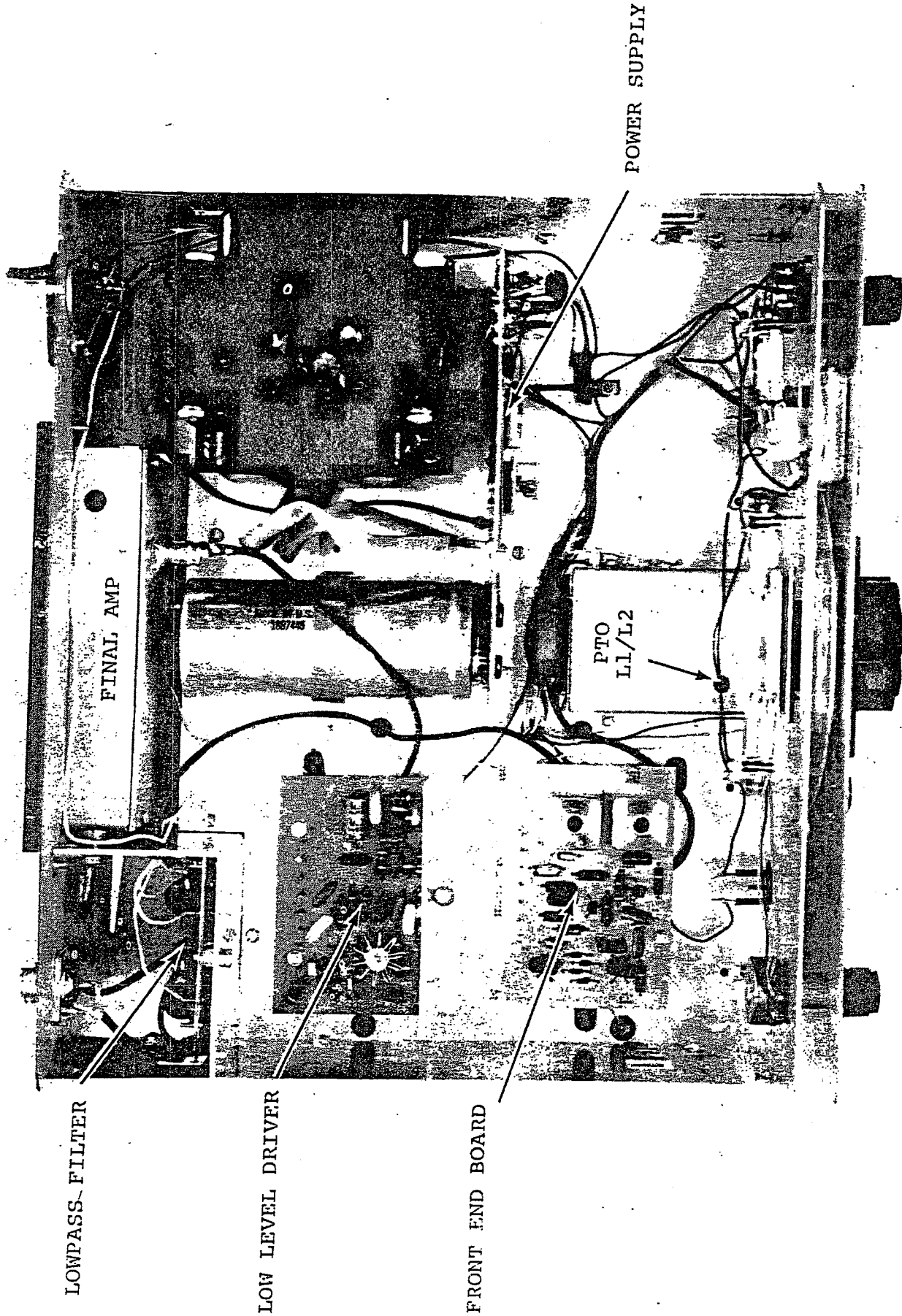

FIGURE 1 - TOP VIEW

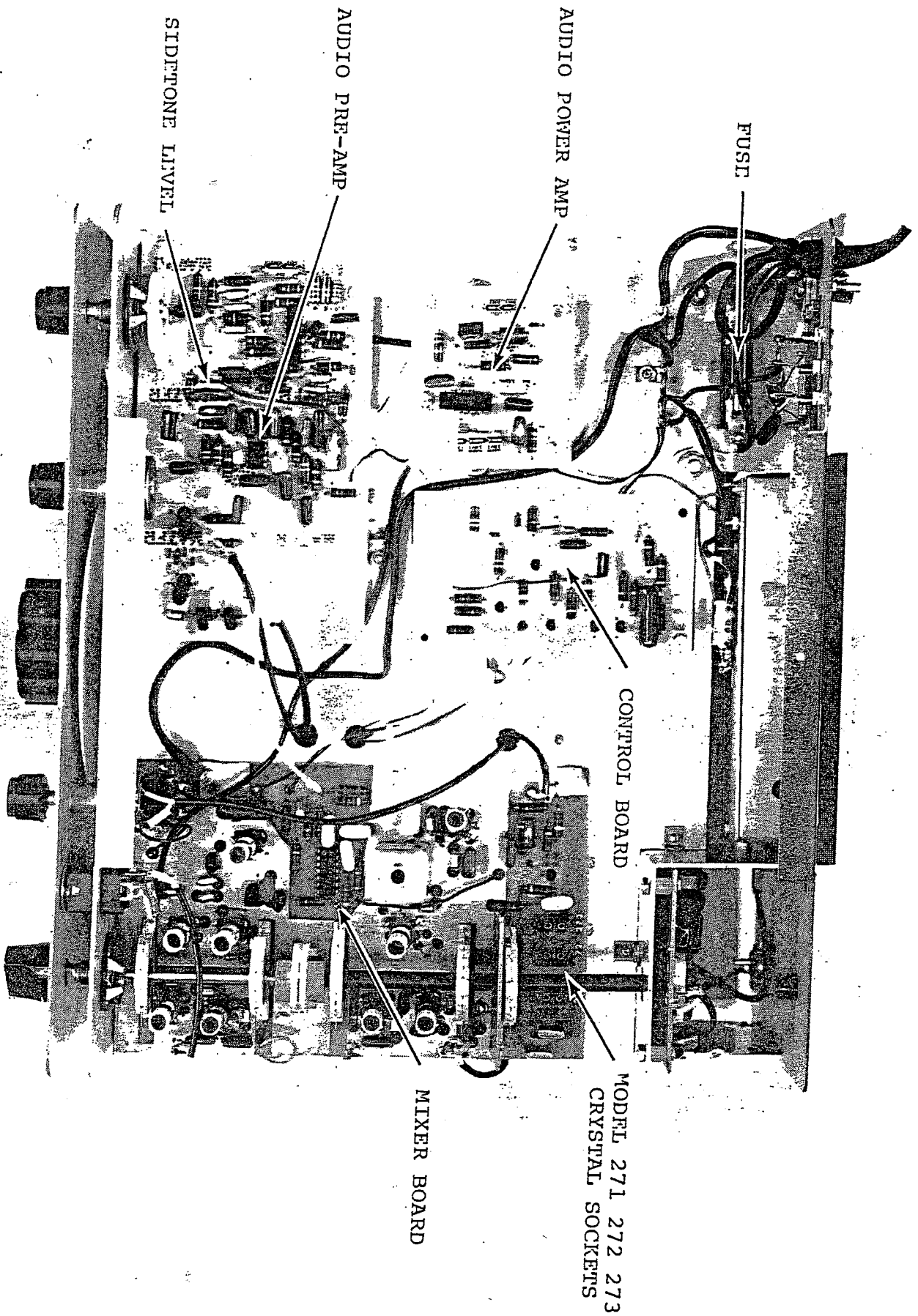

FIGURE 2 - BOTTOM VIEW

80359 FRONT END

This plug-in assembly contains the receiver mixer and i-f amplifier. The mixer is a double balanced diode bridge which receives input signal from the input bandpass filters through T1 and mixes it with the heterodyne crystal oscillator output to produce the 5.0 to 5.5 MHz i-f. Q2 is an i-f amplifier which feeds bandpass filter L1 and L2. Q1, a buffer amplifier, isolates the receiver mixer from the crystal oscillator.

The two coils making up the 5.0 to 5.5 MHz i-f filter are aligned at the factory and should not require field adjustment. They form an over coupled tuned circuit with broad response.

Pin Voltage Readings - (No signal conditions, DRIVE fully CCW)

Pin	Transmit	Receive
INPUT	0	0
XTAL OSC.	9.3	9.3
GND	0	0
R	.2	+11.7
GND	0	0
OUT	0	0
GND	0	0

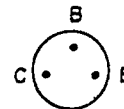

Transistor pins viewed from top of PC board.

Semiconductor Voltage Readings - (Receive)

Transistor	Collector	Base	Emitter
Q1	10.9	2.0	1.3
Q2	9.3	4.7	4.0

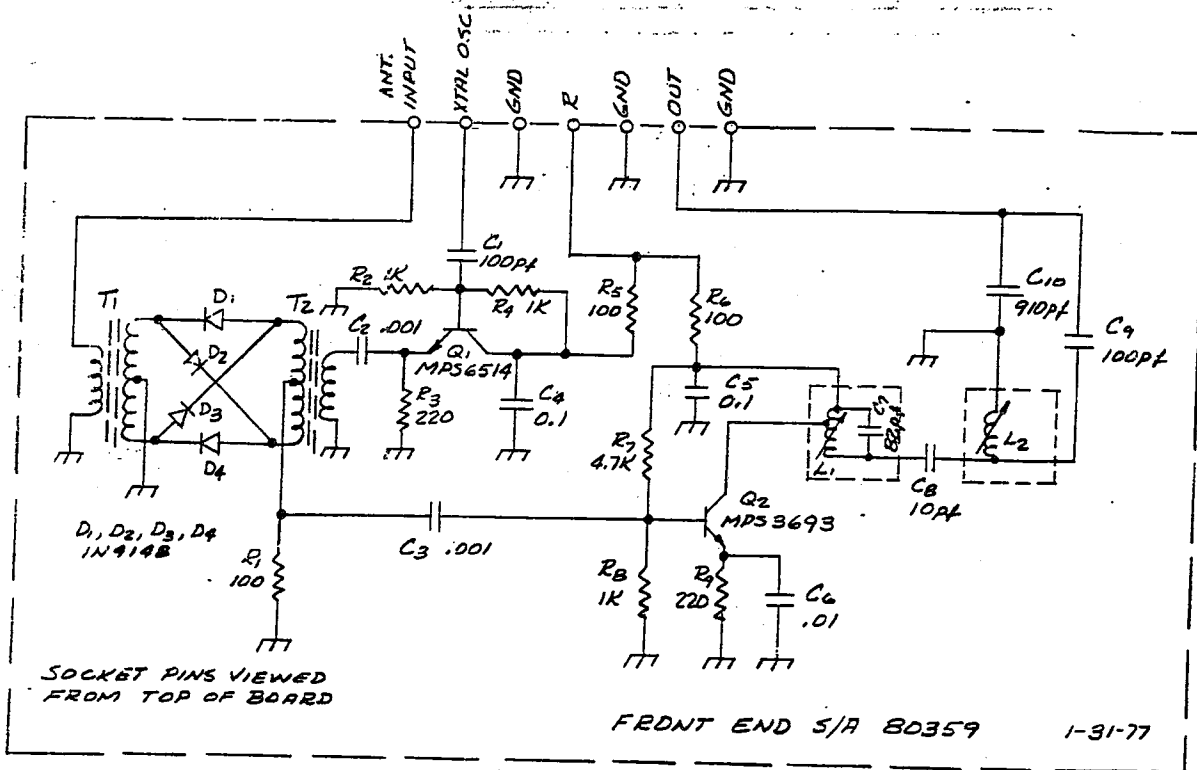
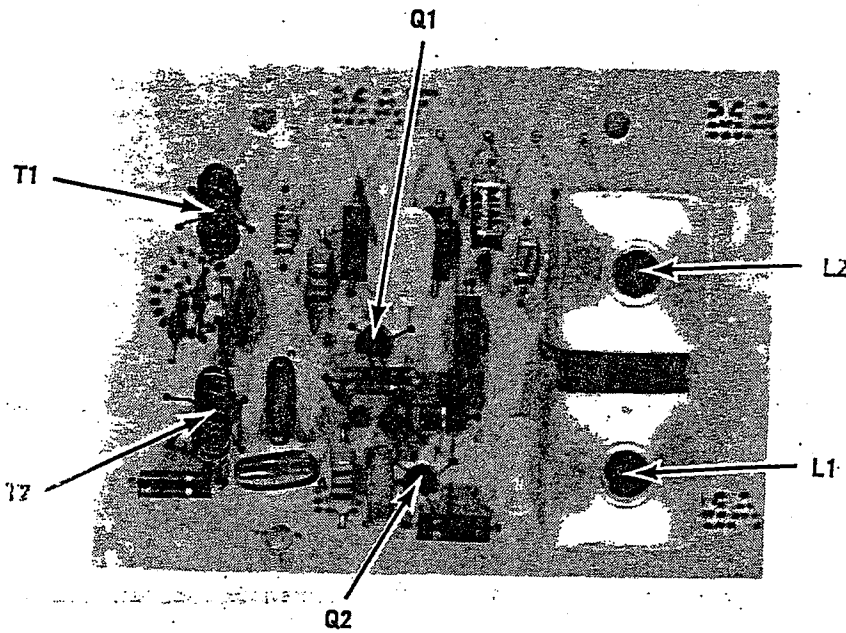

80356 AUDIO PRE-AMP

This board contains the receiver product detector, audio preamplifier, cw filter and sidetone oscillator. The product detector is similar to the receiver mixer except that the signals being mixed are the i-f from the Front End board and the VFO. The recovered audio is applied to a low noise two stage preamplifier, IC-2, which provides 60 dB gain. Response is tailored to provide a 2.5 kHz bandwidth. The preamp output is applied to AF GAIN control, R32. The cw filter consists of three sections of IC-1, the LM3900 quad operational amplifier. The cw filter is 3 sections of active filter, centered on 750 Hz. In the 1.0 kHz position, only one section is used. The .5 kHz position uses all three. The fourth section of IC-1 is used for the sidetone oscillator. Sidetone volume is controlled by thumbwheel potentiometer, R6, which is accessible through a hole in the bottom cover.

Semiconductor Voltage Readings - (Receive, DRIVE fully CCW)

<u>Pin</u>	<u>IC-2</u>	<u>IC-1</u>
1	1.3	0.6
2	1.3	0.6
3	0	0.6
4	7.4	5.5
5	7.5	5.5
6	11.5	0.6
7	1.3	0
8		0
9		5.3
10		0.1
11		0.6
12		0.5
13		0.6
14		11.5

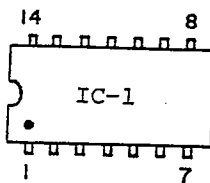
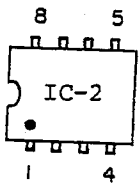

IC pins viewed from
top of PC board.

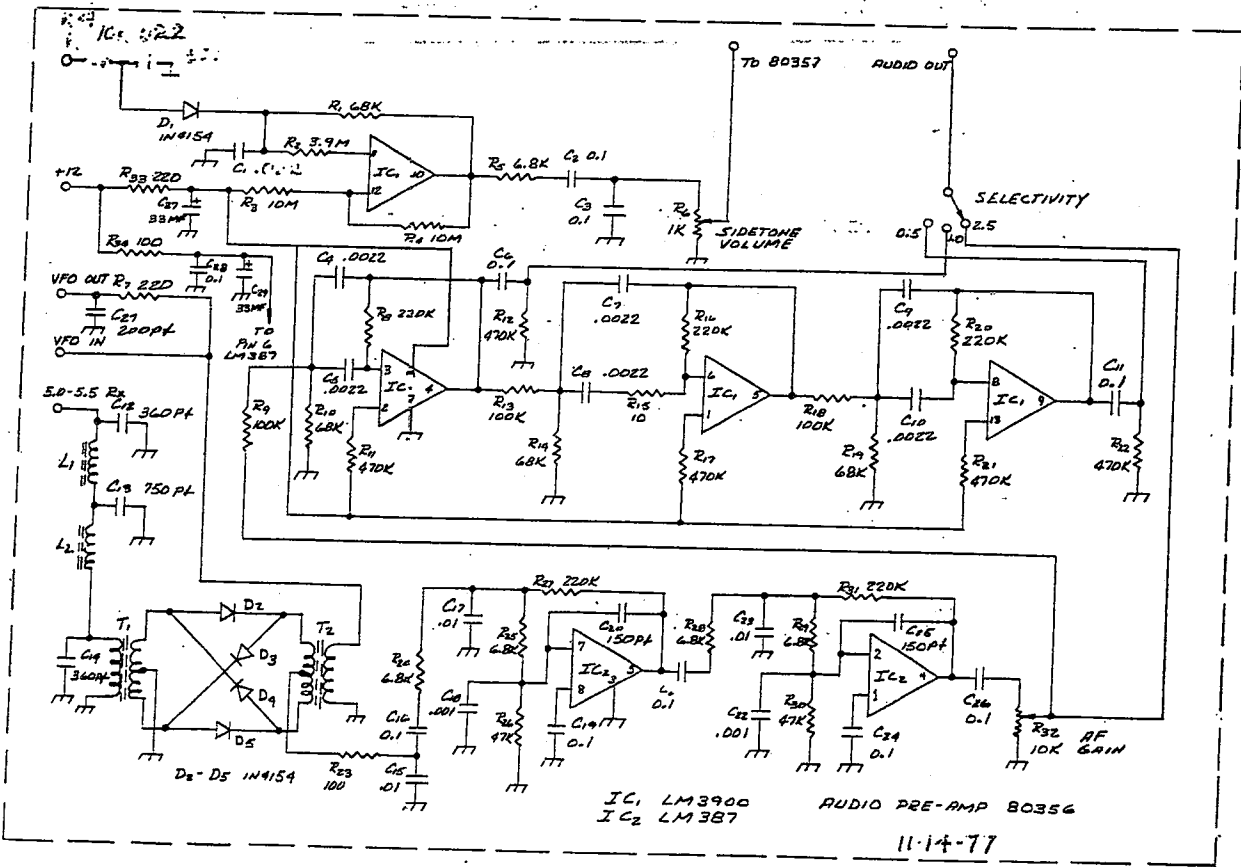
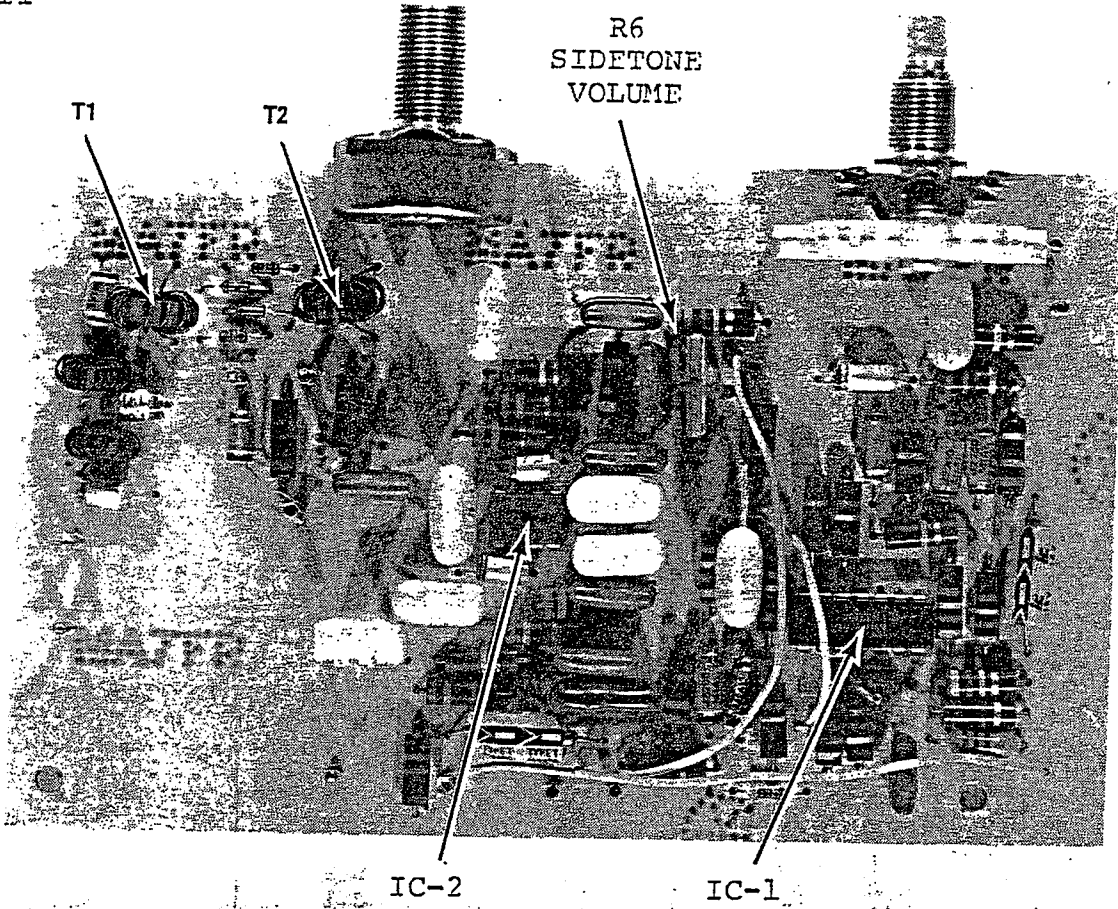

AUDIO PRE-AMP 80356

80357 AUDIO POWER AMP

Integrated circuit IC-1 contains the complete audio power amplifier. Input is applied at pin 2 and output taken from pin 8. The input signal is taken from either the received signal at the INPUT terminal, which passes through muting switch Q1, or from the SIDETONE terminal.

The input signal is shorted to ground whenever muting switch transistor Q1 is turned on. This occurs in the transmit mode by the application of the "T" voltage to its base circuit through D1. D1, C1, R1 and R2 form a delay circuit to slightly delay the turn-on time of the audio signal after transmitting.

Pin Voltage Readings - (No signal conditions, DRIVE fully CCW)

Pin	Transmit	Receive
T	10.2	0
SIDETONE	0	0
INPUT	0	0
GND	0	0
GND	0	0
+12v	12.8	12.8
OUT	0	0

Semiconductor Voltage Readings

Transistor	Collector		Base		Emitter	
	Transmit	Receive	Transmit	Receive	Transmit	Receive
Q1	0	0	0.6	0	0	0

IC-1

Pin	Pin	Pin	Pin
1	6.5	8	6.2
2	0	9	6.2
3	0	10	0
4	0	11	0
5	0	12	0
6	0	13	0
7	0	14	12.6

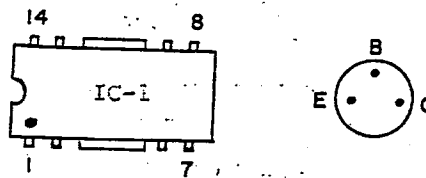

Semiconductor pins viewed from top of PC board.

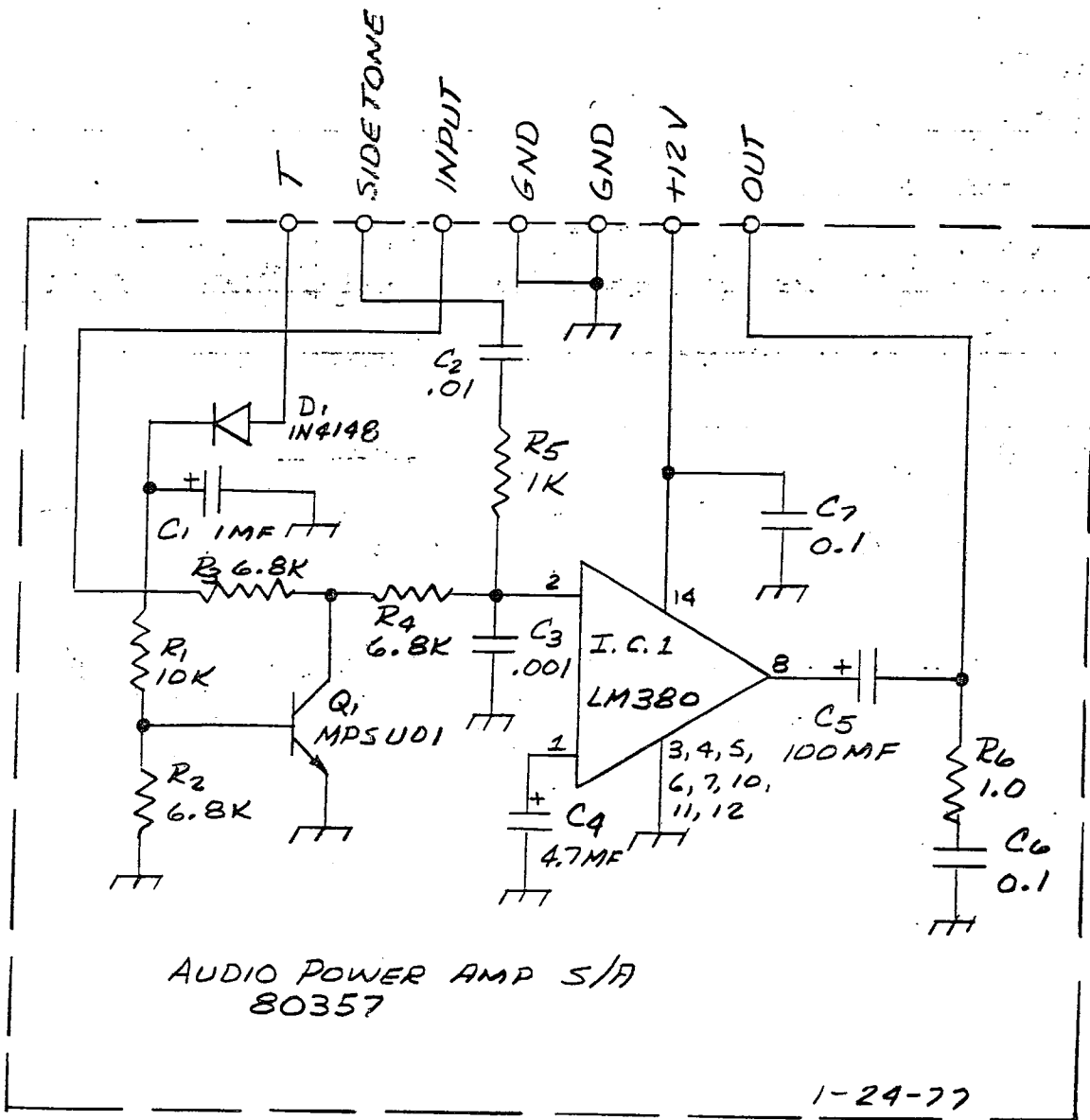
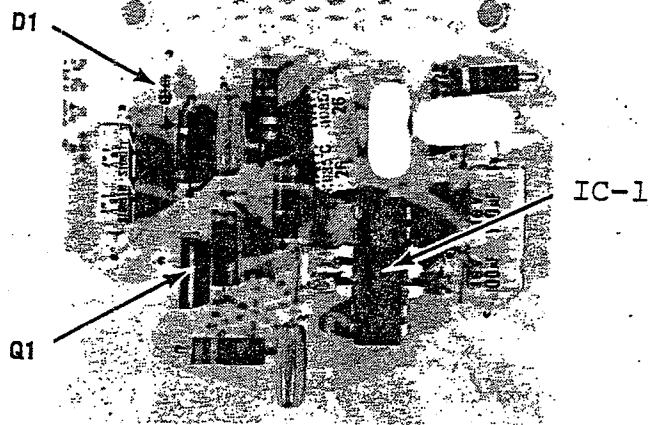

80278 PTO

The permeably tuned oscillator provides the VFO for receive and the injection signal on transmit. It is housed in a sealed enclosure on top of the main chassis. The main coil, L3, is shunted with L2 and has L1 in series. Adjustment of these two slug tuned coils, which are on the same coil form, determines the linearity and band edge points. L2 is the top slug, L1 is the bottom slug.

PTO Alignment

1. Adjust the OFFSET control for zero offset. Connect a frequency counter to the PTO output terminal located on the right rear of the enclosure. Couple counter as lightly as possible while obtaining a stable indication. Counter should have an input sensitivity of at least 100 mV.
 2. Set the BAND switch to 14.0 MHz and the main tuning knob to full CCW rotation. The dial indication should indicate 50 kHz below the band edge, plus or minus 10 kHz. If it does not, push down on the spring loaded idler gear arm with a long screwdriver to disengage the dial drive gear and move the dial to indicate 50 kHz below the band edge.
 3. Turn the tuning knob to indicate 14.000 MHz and observe the counter reading. If it is not 5.000 MHz, slightly touch up the L2 slug. Slug position in the coil should be such that a clockwise rotation decreases frequency.
 4. Run the tuning knob up scale and observe the counter readings at each 100 kHz point. If readings are within ± 5 kHz, linearity is within specification. However, in most all cases, linearity may be improved, especially if the reading at 5.500 (14.500 dial) MHz is not exactly aligned, or if all deviations from the first setting are in the same direction.
 5. If the PTO range is compressed, i.e. reading on counter at what should be 5.5 MHz is less than this, reset tuning to 5.0 position, turn L2 slug a fraction of a turn clockwise and compensate for the decrease in frequency by turning L1* slug also clockwise for a 5.0 MHz counter reading. Repeat Step 4 to see if the correction was enough or too much.
 6. If the range of the PTO is expanded instead of compressed, compensation in the opposite direction is indicated. This is done by turning the slugs in the opposite direction.
- * NOTE: To reach L1 without disturbing the setting of L2, use the tuning tool with the reduced shank that is provided with the Century/21. Also note that L2 is used to adjust the spread of the PTO range and L1 is used to set the frequency to the correct value.

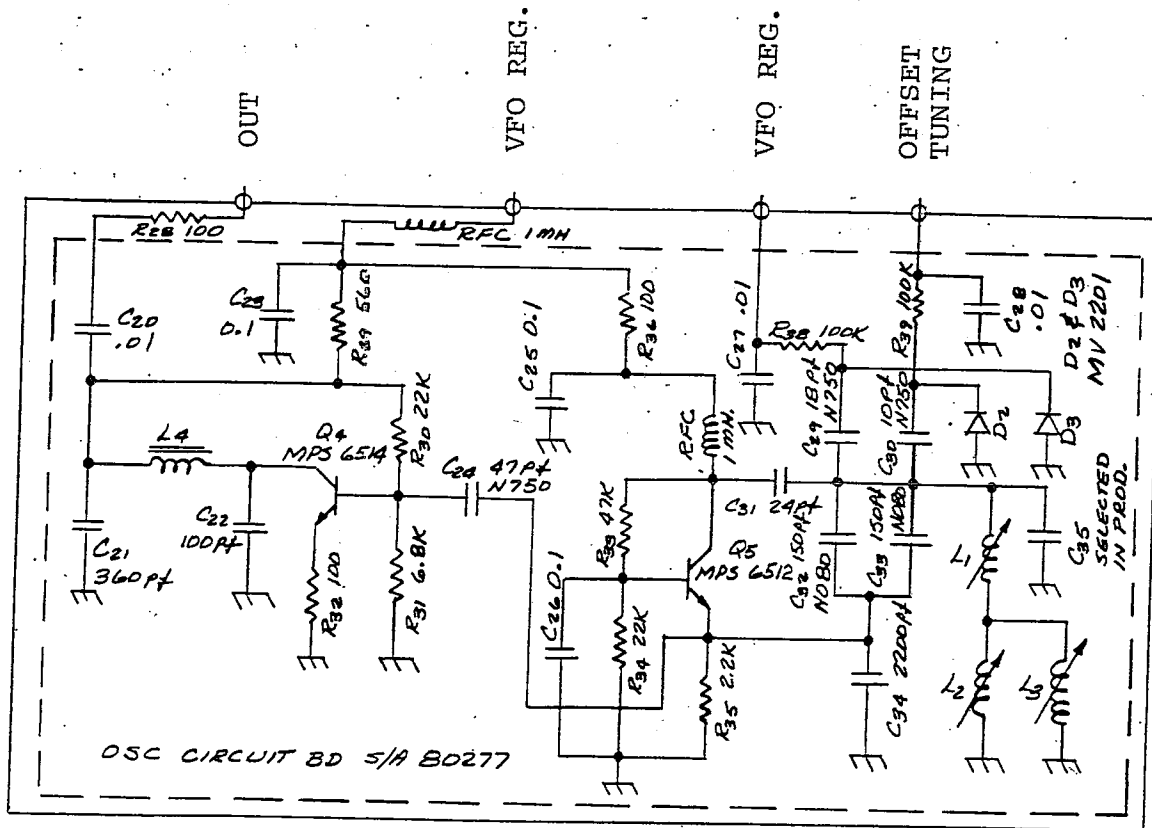
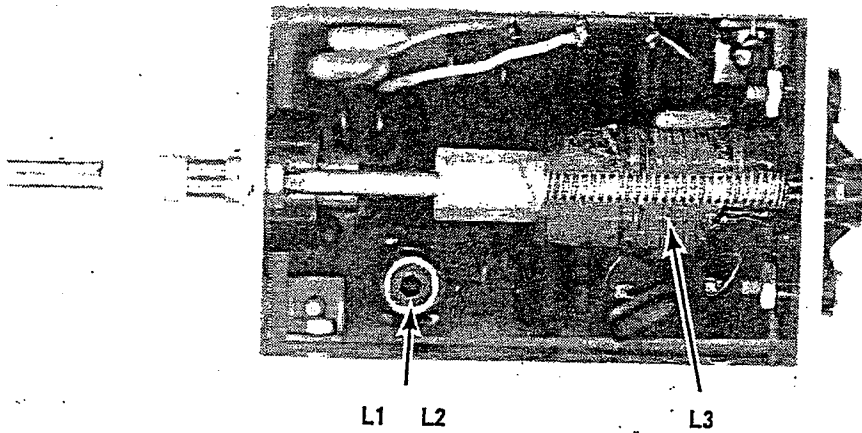

PTO 80278

This assembly contains all of the switched bandpass circuits, the crystal heterodyne oscillator and the transmitter mixer. Transformers T1 through T5 are the transmit bandpass circuits and T6 through T10 are the receiver antenna coupling bandpass circuits. All are overcoupled tuned circuits and being fairly broad, require no field alignment.

IC-1 is an active double-balanced mixer which generates the transmitted signal by mixing the VFO signal with the crystal oscillator signal.

Q1, the crystal oscillator, feeds both receiver and transmitter mixers. Sockets for the accessory crystals are located along the back edge of the board.

Semiconductor Voltage Readings - (Receive, DRIVE CCW)

Transistor	Collector	Base	Emitter
Q1	12.2	9.5	9.7

IC-1

Pin	
1	5.2
2	5.8
3	5.8
4	5.2
5	0
6	12.4
7	12.4
8	9.0
9	0
10	9.0
11	0
12	11.9
13	0
14	0

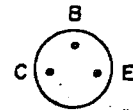
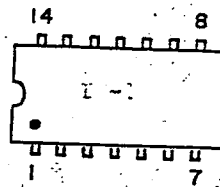

Semiconductor pins viewed
from top of PC board.

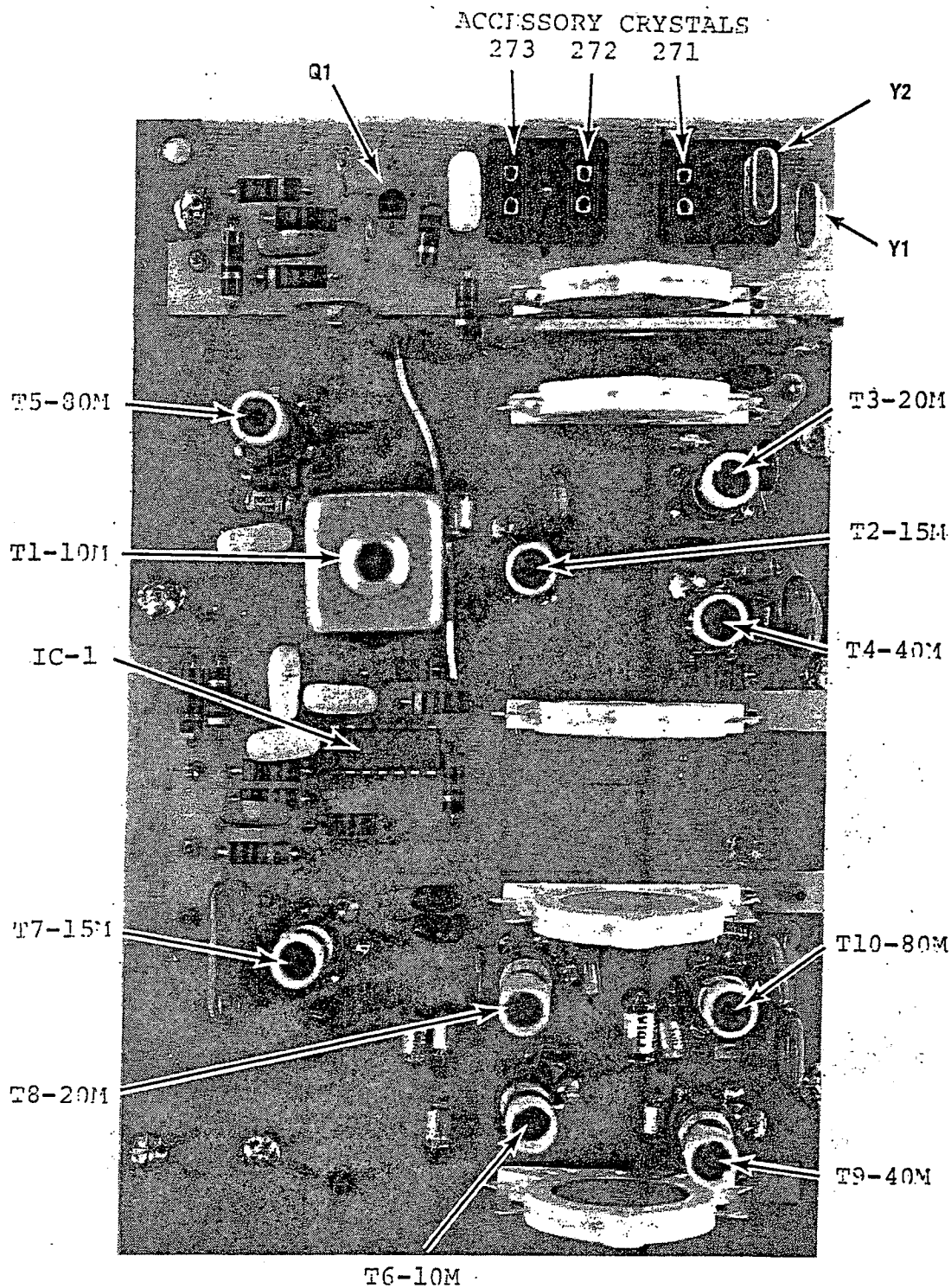

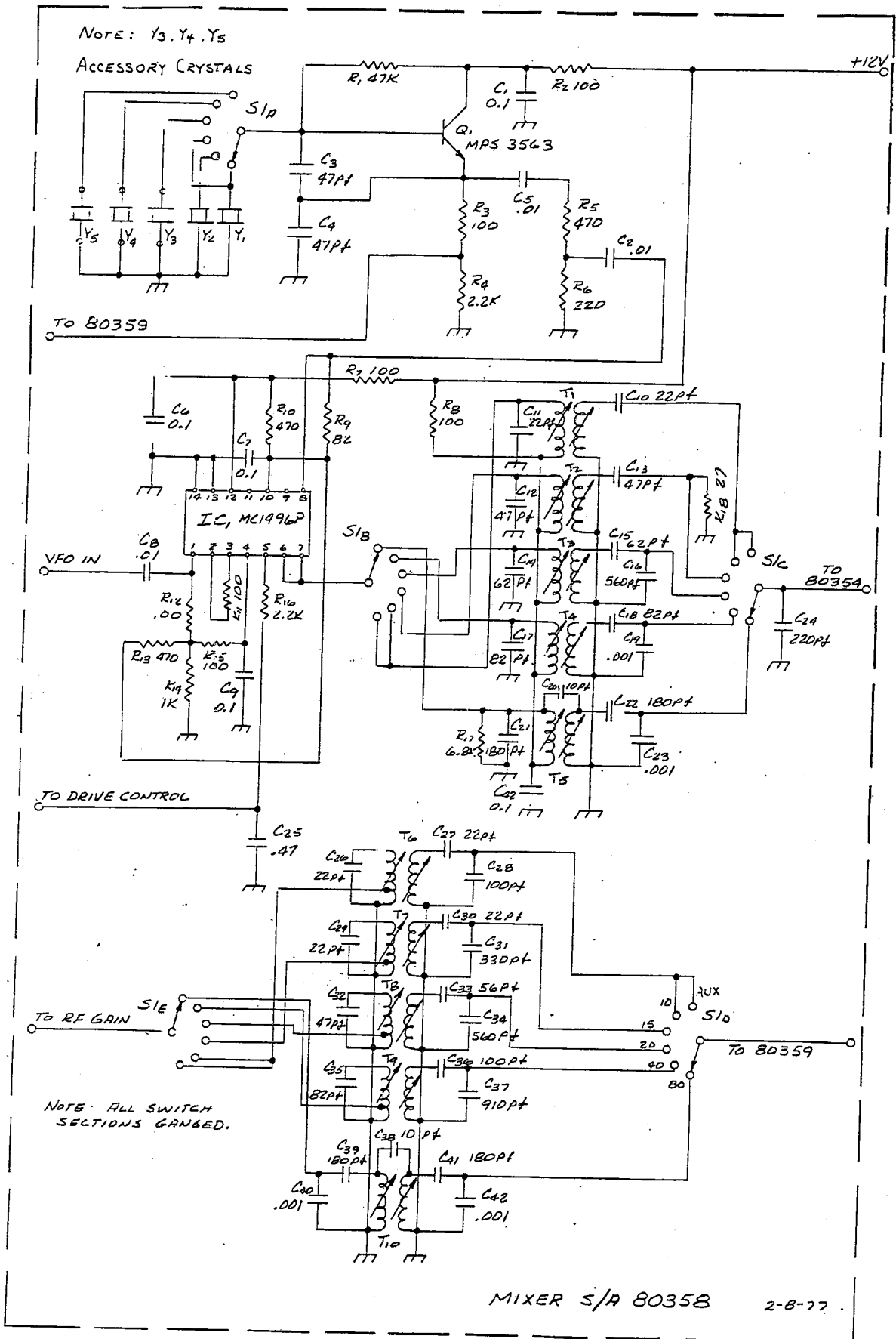

80354 LOW LEVEL DRIVER

This assembly contains three Class A linear amplifier stages to increase the level of the signal from the transmit mixer to that required to drive the final amplifier. The second and third stages, Q2 and Q3, are biased from the "T" line by diodes D1 and D2. Since all three amplifiers are broad band designs, no tuning or adjustments are necessary.

Pin Voltage Readings - (DRIVE fully CCW)

Pin	Transmit	Receive
GND	0	0
IN	0	0
T	10.2	0
NC	-	-
OUT	0	0
+12	12.6	12.6
GND	0	0

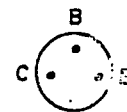

Transistor pins viewed from top of PC board.

Semiconductor Voltage Readings - (DRIVE fully CCW)

Transistor	Collector		Base		Emitter	
	Transmit	Receive	Transmit	Receive	Transmit	Receive
Q1	6.5	7.4	1.5	1.8	0.8	1.1
Q2	9.4	11.4	1.2	0	0.5	0
Q3	12.6	12.6	1.3	0	0.6	0

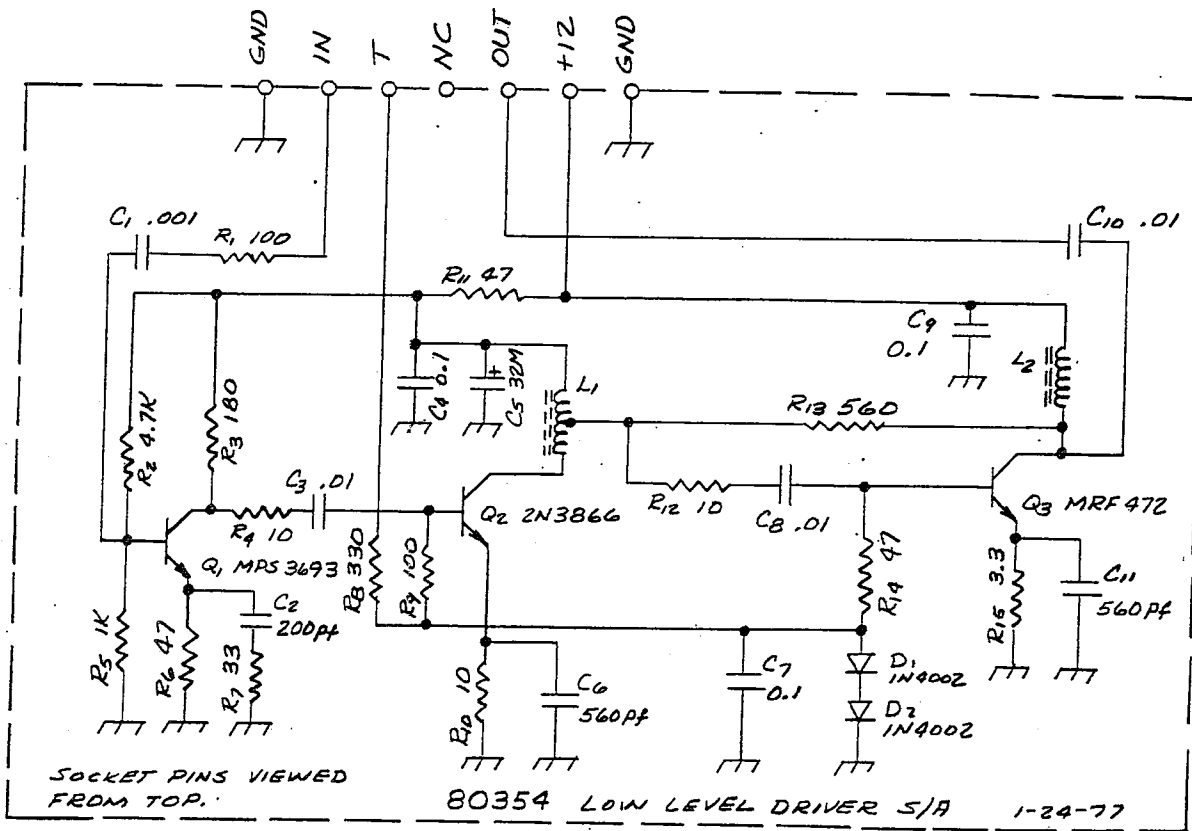
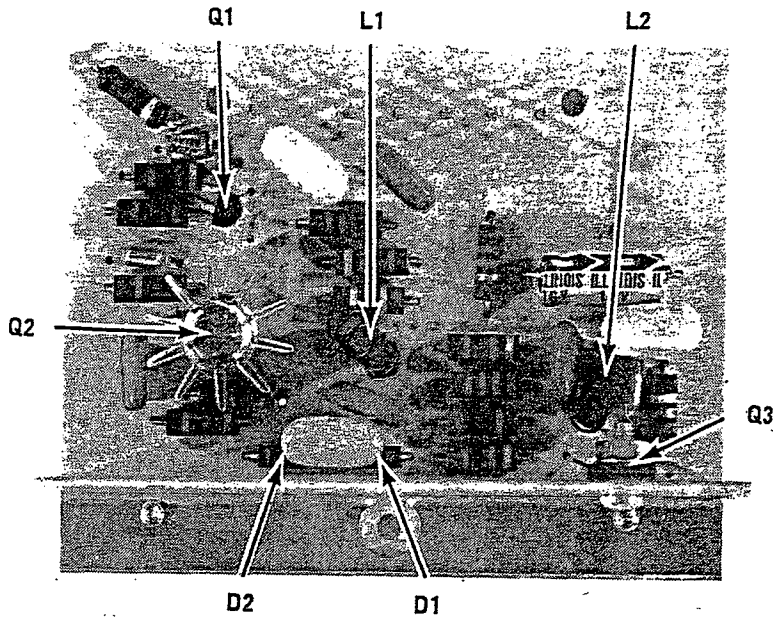

LOW LEVEL DRIVER 80354

80361 FINAL AMPLIFIER

The high power rf amplifier and its push-pull driver stage are housed in a metal box which is an integral part of the heat sink assembly. The unit is attached to the rear panel by four screws and connections are made by means of two phono connectors for rf input and output and three soldered-on leads for control and power.

Q1 and Q2 constitute a Class AB linear push-pull driver stage of wide band design. Impedance matching into and out of this stage is by means of transformers T1 and T2. Operating bias is applied whenever voltage is applied to the "T" terminal. Quiescent current in the collector circuit is adjusted to 6 mA by potentiometer R5.

Power amplifier transistors Q3 and Q4 are biased to Class C.

Bias for the driver stage is temperature compensated to maintain a relatively constant operating point by mounting the bias diode in direct contact with the heat sink.

Since all transistors are inaccessible inside the shield enclosure, no voltage measurements can be made at their terminals. However, voltages going to the feedthrough terminals can be checked to the following values:

Terminal	Wire Color	Transmit	Receive
Final +12	red	+12.5	+12.5
Driver +12	red	+12.5	+12.5
T	blue	+10.2	0.0

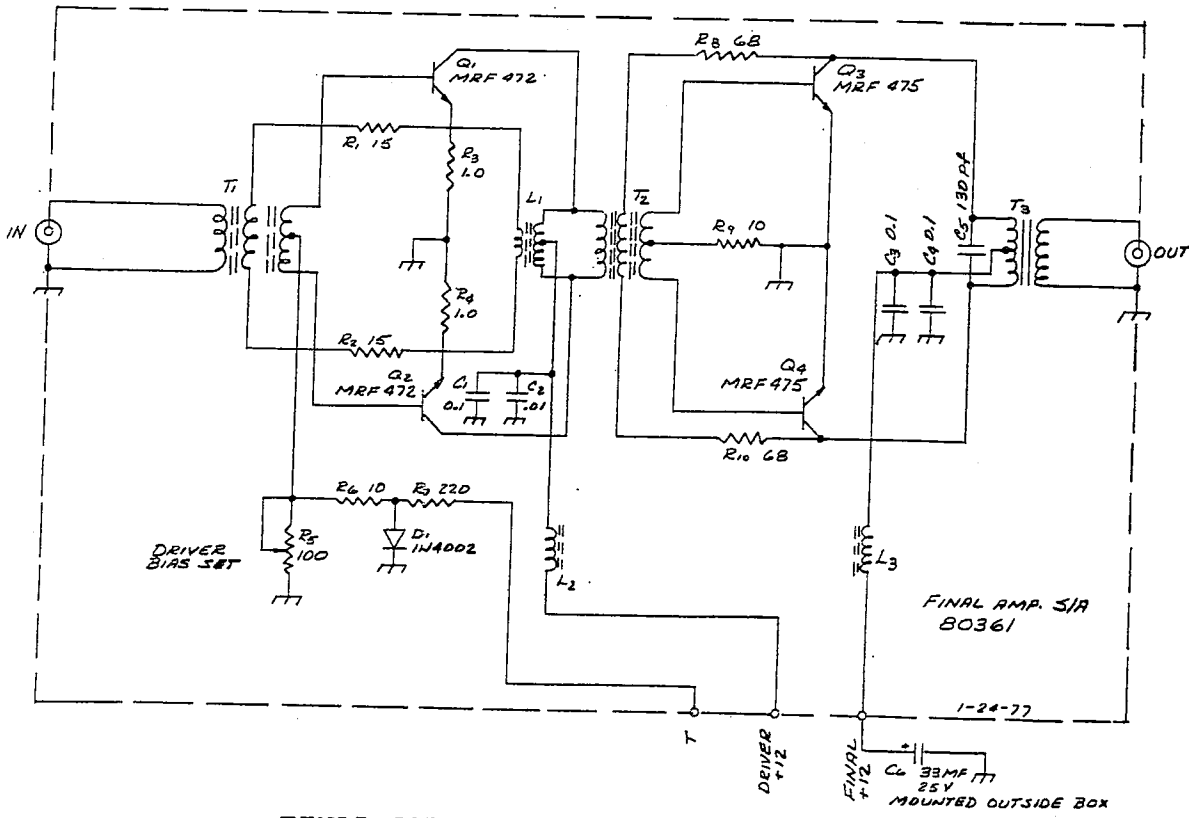
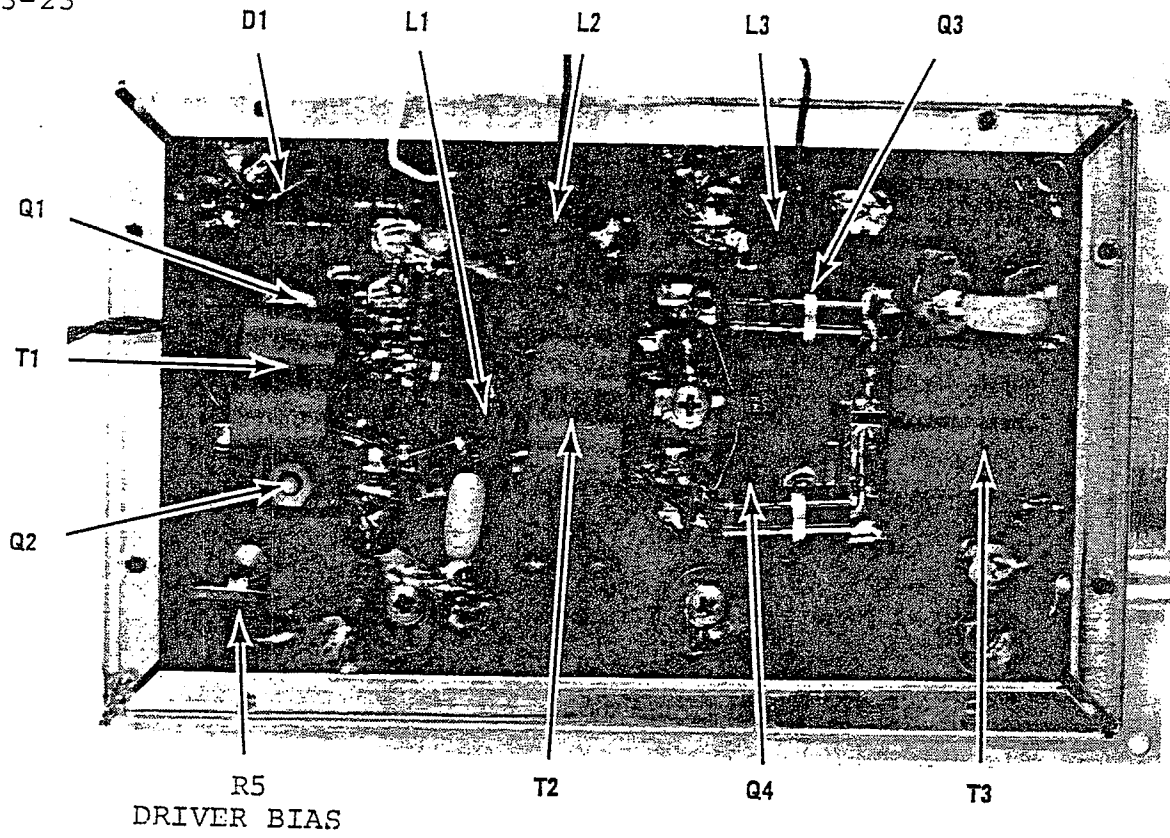

FINAL AMPLIFIER 80361

80360 LOW PASS FILTER

The output signal from the final rf amplifier contains harmonic components above desirable levels. The push-pull configuration decreases the even order components to some degree, but does not cancel out the odd harmonics. To further decrease evens and odds, the output signal is passed through a set of five pole low pass filters before being radiated. The proper filter is selected by the BAND switch.

This assembly also contains the T/R antenna switch. This circuit disconnects the receiver input from the antenna whenever the key line is shorted. The circuit consists of a PIN diode and transistor switch. In the receive mode the PIN diode is forward biased providing a low loss path between the antenna and the receiver. In transmit the transistor is biased off and the diode is reverse biased by approximately 23 volts from the power supply, which essentially disconnects the receiver from the antenna.

Semiconductor Voltage Readings - (DRIVE fully CCW)

Transistor	Collector		Base		Emitter	
	Transmit	Receive	Transmit	Receive	Transmit	Receive
Q1	23	0.2	0	0.7	0	0

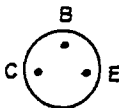

Transistor pins viewed from
top of PC board.

S1f S1g

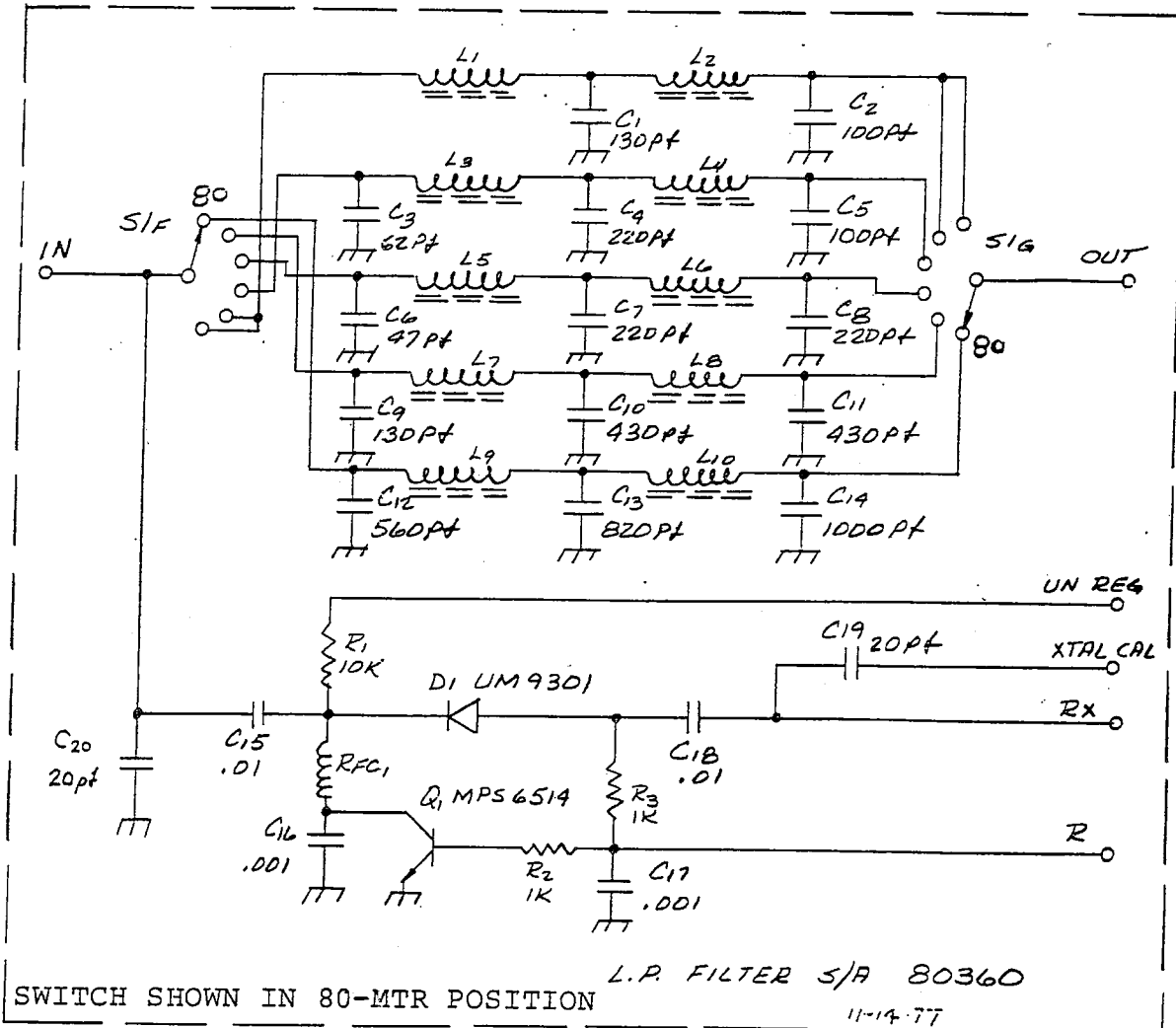
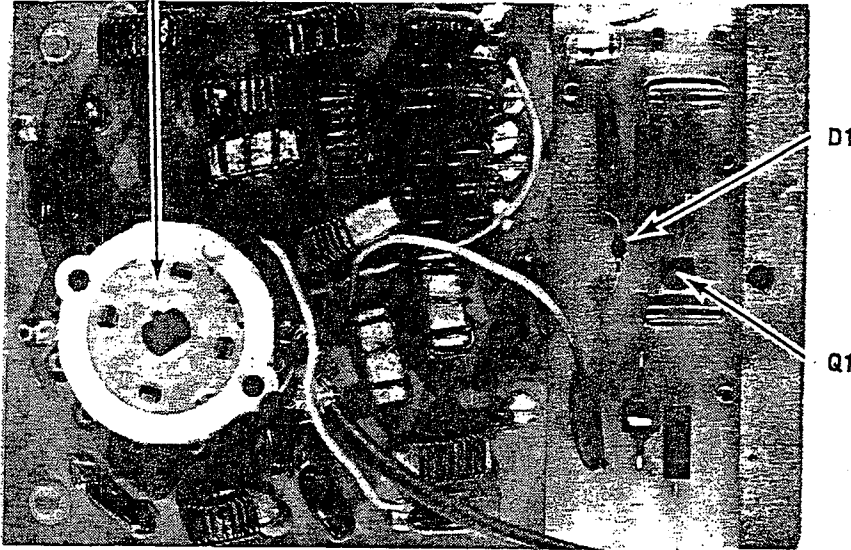

SWITCH SHOWN IN 80-MTR POSITION

L.P. FILTER S/A 80360

11-14-77

LOW PASS FILTER 80360

80355 CONTROL BOARD

This assembly contains a set of synchronous transistor switches which control the "T" and "R" voltages that switch the CENTURY from receive to transmit. It also provides a regulated voltage which powers the PTO and offset tuning circuitry.

Transistors Q1, Q2, and Q3 constitute the "T" voltage switch which produces operating voltage on the "T" terminal whenever the KEY line is closed. The presence of "T" voltage at the base of Q4 switches off the normally present "R" voltage through switches Q5 and Q6.

The OFFSET control voltage for the varactor diode in the PTO is derived through steering diode D3 through terminal OT. The amount of control voltage varies between 3 and 6 volts as determined by the setting of the OFFSET control and resistors R13 and R18. When transmitting or with the ZERO BEAT switch pushed, Q8 is turned on, back biasing D3 and thereby disconnecting the voltage divider from the OT terminal. At the same time, Q7, which was previously turned on and back biasing D2, goes to an off state and inserts the voltage from the divider formed by resistors R10, R11 and R12, through the forward biased D2 to the OT terminal. Trimpot R12 is adjusted to a value equal to the center position voltage of the OFFSET control, in essence the voltage representing no offset.

To adjust R12, turn the OFFSET control to its center zero position. Tune in a station with the main tuning knob and adjust to zero beat. Then push the ZERO BEAT button and adjust R12 for the same pitch. Check by retuning to a slightly different pitch and pushing the ZERO BEAT knob. The pitch should stay the same.

Pin Voltage Readings - (DRIVE fully CCW, OFFSET knob centered)

Pin	Transmit	Receive	Pin	Transmit	Receive
GND	0	0	OT POT	0	2.5
KEY	0	4.5	OT ON/OFF	.7	0
+12	12.5	12.5	T	10.1	0
NC	-	-	OT POT	0	4.3
NC	-	-	R	0	10.9
+9	8.9	8.9	OT POT	3	5.8
GND	0	0	OT	3.8	3.8

Semiconductor Voltage Readings

Transistor	Collector		Base		Emitter	
	Transmit	Receive	Transmit	Receive	Transmit	Receive
Q1	11.9	.1	0	.7	0	0
Q2	12.6	12.6	11.9	.13	11.2	0
Q3	0	0	10.7	.1	10.0	0
Q4	.1	12.1	.7	0	0	0
Q5	12.6	12.6	.1	12.1	0	11.4
Q6	0	0	.1	12.1	.1	10.9
Q7	4.3	0	0	.6	0	0
Q8	0	4.3	.7	0	0	0

Transistor pins viewed
from top of PC board

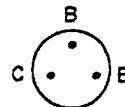

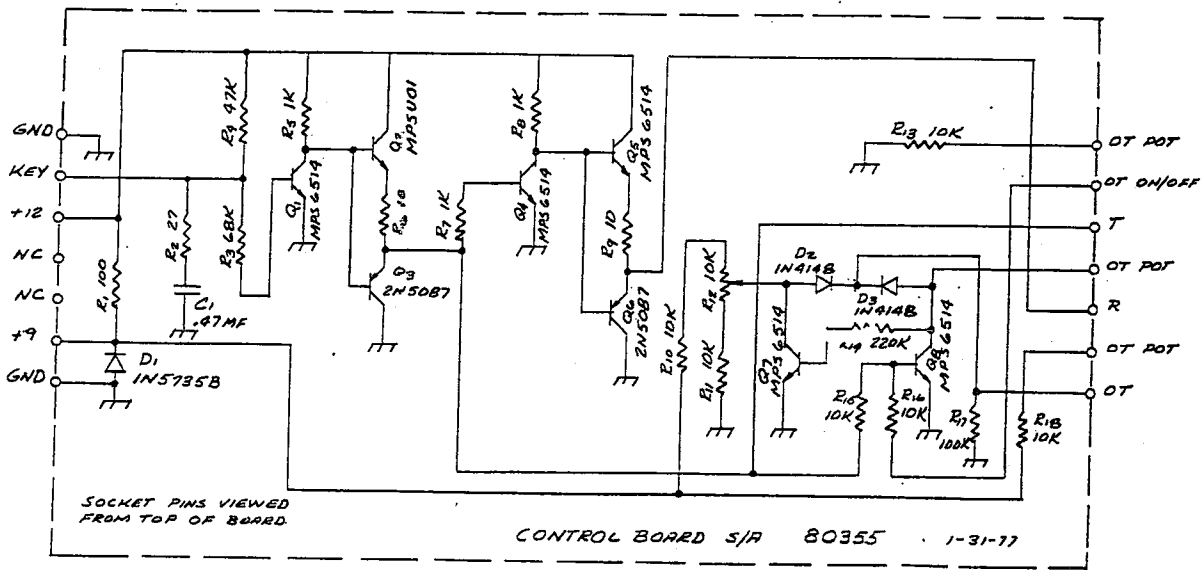
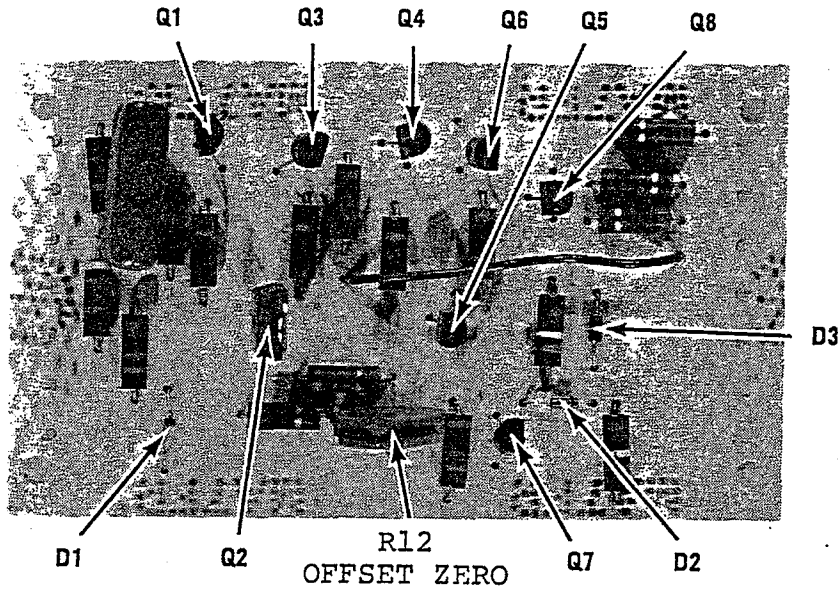

CONTROL BOARD 80355

80353 POWER SUPPLY

This assembly contains a bridge rectifier, filter capacitor, regulator, shut-down circuits and the meter shunt. The output voltage is fixed at 12.8v and the current trip is set to 6A at the factory. Voltage regulation is provided by IC-1 which drives the darlington series pass element consisting of Q1 and the 2N3055 mounted on the rear panel. When current drawn from the supply exceeds the trip value as determined by the setting of R1, sufficient gate drive is applied to SCR Q2 to turn it on. This shorts the output of IC-1 and removes base drive from the series pass element. Under this condition, IC-1 is protected by the voltage drop across R5 which activates the current limiting circuits inside the integrated circuit. The front panel meter is calibrated by means of thumbwheel potentiometer R7.

Calibration of the meter and trip point requires an adjustable 2.5 ohm 100 watt load resistor and a 10 ampere dc meter. The load resistor and ammeter are connected in series and bridged across one of the Aux 12 VDC output jacks on the rear panel. Calibrate meter in receive mode and not transmit. The load resistor is adjusted for a current of 6 amperes as indicated on the ammeter and R7 is set for a meter reading of 70 watts. Then R1 is adjusted so the power supply trips at the same 70 watt point.

Semiconductor Voltage Readings - (Receive mode)

Transistor	Collector	Base	Emitter
Q1	23.0	13.8	13.2
	Anode	Cathode	Gate
Q2	13.8	-.06	-.03

IC-1	Normal	Tripped
1	0	0
2	13.8	8.0
3	13.8	.8
4	0	0
5	7.0	6.3
6	7.0	6.3
7	0	0
8	0	0
9	7.6	1.6
10	13.8	5.5
11	23	15.6
12	23	15.6
13	14.9	6.7
14	0	0

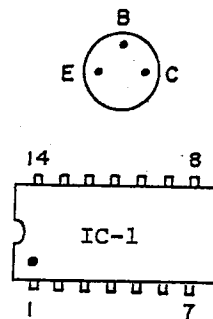

Semiconductor pins viewed from top of PC board.

R6 METER
CALIBRATE

R1 CURRENT
LIMIT ADJ.

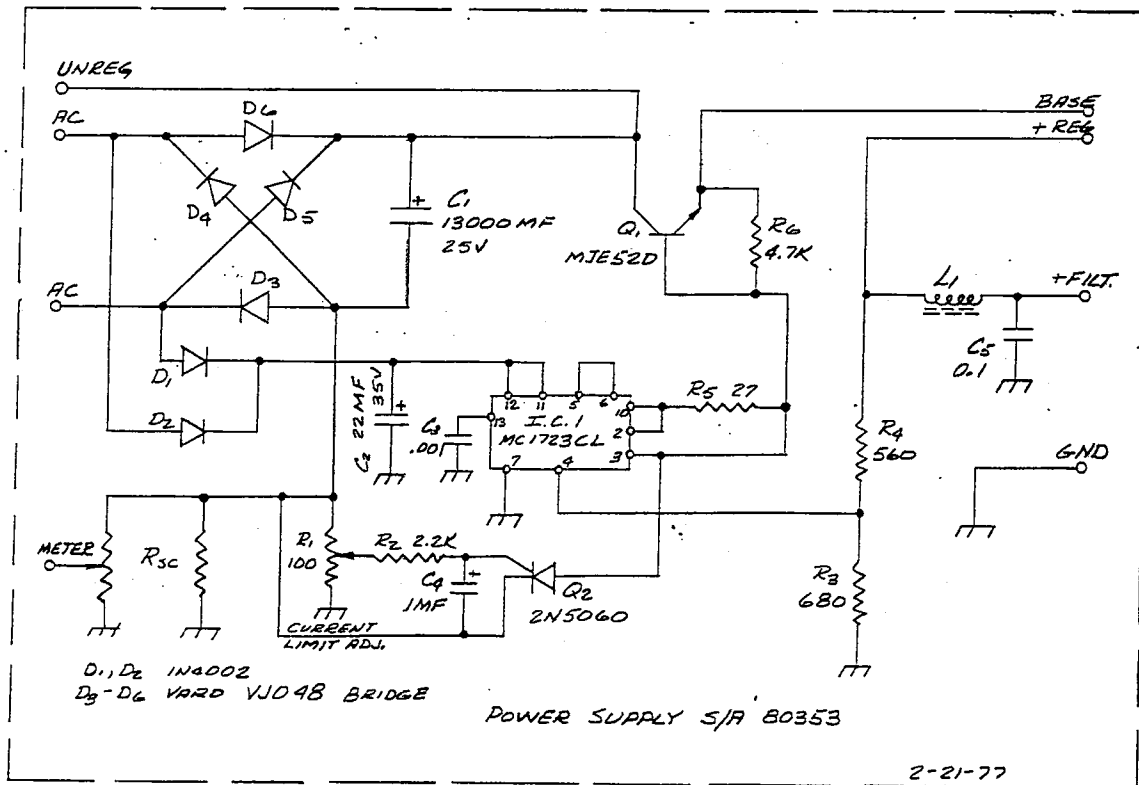
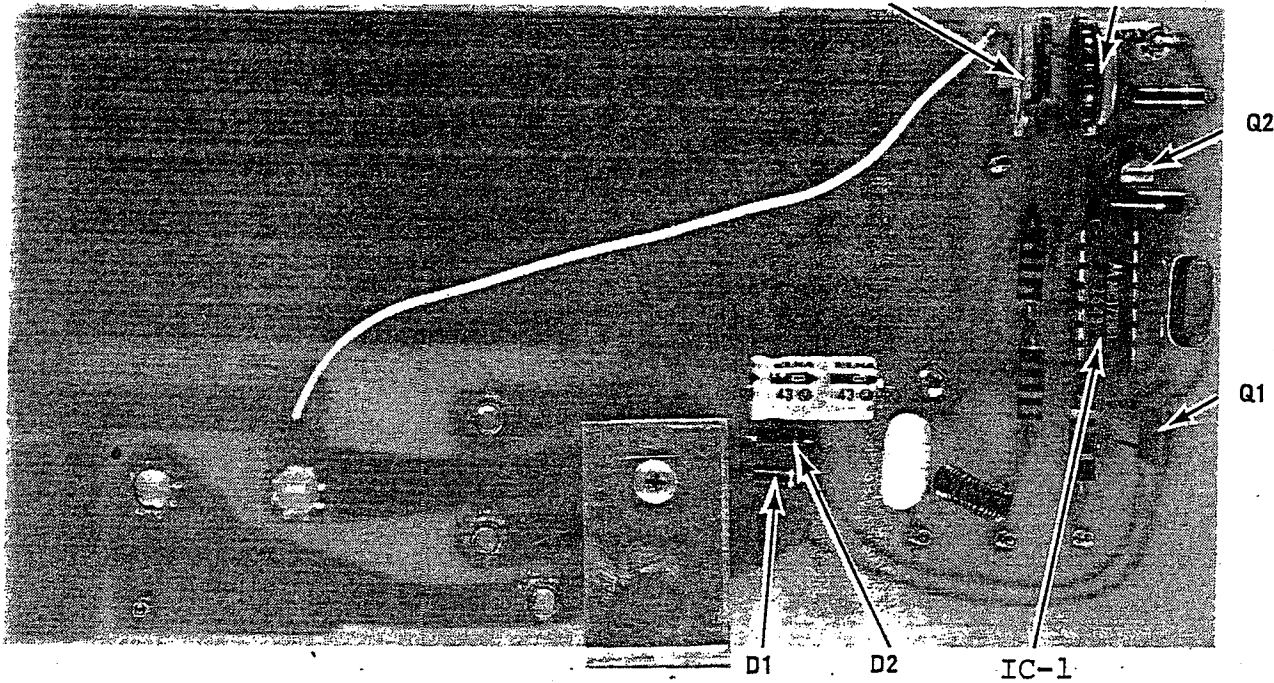

POWER SUPPLY 80353

Ten-Tec, Inc.
1185 Dolly Parton Parkway
Sevierville, TN 37862
Repair Service: (865) 428-0364

LIMITED WARRANTY AND SERVICE POLICY, U.S.A. AND CANADA

Ten-Tec, Inc., warrants this product to be free from defects in material and workmanship for a period of one (1) year from the date of purchase, under these conditions:

1. **THIS WARRANTY APPLIES ONLY TO THE ORIGINAL OWNER.** It is important that the warranty registration card be sent to us promptly.
2. **READ THE MANUAL THOROUGHLY.** This warranty does not cover damage resulting from improper operation. Developing a thorough understanding of this equipment is your responsibility.
3. **IF TROUBLE DEVELOPS** we recommend you contact our customer service group direct at the address or phone number shown above. It has been our experience that factory direct service is expeditious and usually results in less down-time on the equipment. Some overseas dealers do offer warranty service and, of course, have our complete support.
4. **EQUIPMENT RETURNED TO THE FACTORY** must be properly packaged, preferably in the original shipping carton(s). You pay the freight to us and we prepay surface freight back to you. Canadian customers must have proper customs documentation sent with incoming repair equipment. Duties or fees charged due to improper documenting are the responsibility of the owner of the equipment.
5. **EXCLUSIONS.** This warranty does not cover damage resulting from misuse, lightning, excess voltages, polarity errors or damage resulting from modifications not recommended or approved by Ten-Tec. In the event of transportation damage, a claim must be filed with the carrier. Under no circumstances is Ten-Tec liable for consequential damages to persons or property caused by the use of this equipment.
6. **TEN-TEC RESERVES** the right to make design changes without any obligation to modify equipment previously manufactured, or to notify owners of changes to existing equipment.
7. **THIS WARRANTY** is given in lieu of any other warranty, expressed or implied.

SERVICE OUTSIDE OF THE U.S.A. OR CANADA

Many of our international dealers provide warranty service on the equipment they sell. Many of them also provide out of warranty service on all equipment whether they sold it or not. If your dealer does not provide service or is not conveniently located, follow the procedure outlined above. Equipment returned to us will be given the same attention as domestic customers but roundtrip freight expense, customs and broker fees will be paid by you.

Part no. 74244