

Tuna Tin 2 QRPp Transmitter Kit

WELCOME!

Thanks for purchasing the Tuna Tin 2 Transmitter kit! We believe you'll have lots of fun putting this together, and you'll end up with a useful QRPp (i.e., very low power) transmitter that can be used regularly on the popular QRP frequency of 7.040 MHz.

This manual consists of some background material that describes how the project originated, and the construction guide to assist you in putting it together. Schematics, parts list, assembly diagrams, etc. are all provided.

This kit has also been updated slightly for better performance in the area of the output transformer (T1), as well as in the low pass filter on the output. Dave Fifield (AD6A), Dave Meacham (W6EMD) and some others on the QRP-L email reflector provided these late-breaking improvements. Thanks guys!

The Tuna Tin 2 was the starting point for the NorCal QRP Club's "Back to the Future" series of projects, whereby some of the oldie-but-goodie QRP circuits from the '60s were "revisited" by modernizing some of the components and providing circuit boards for homebrewers to experiment with. Doug Hendricks, KI6DS and the NorCal QRP Club featured this "TT2" project on their website (as we also did on the NJQRP website) and several articles were presented in the popular QRP journals last year. Much of the background that follows is from the KI6DS write-up describing the classic W1FB project call the Tuna Tin 2.

BACKGROUND

(by Doug Hendricks, KI6DS)

The Tuna Tin 2 was originally designed by Doug DeMaw, W1FB in 1976. It appeared in QST, and was subsequently built by hundreds of QRPers who were attracted to the project by the relatively easy parts availability. In fact, at the time of publication of the article, you could stop by the local Radio Shack and pick up everything needed except for the crystal.

When I looked at the article in the summer of 1996 and decided to build another Tuna Tin 2, I discovered that all of the parts were not available from Radio Shack. I contacted Dave Meacham, W6EMD, and he agreed to look at the article and update the parts to modern, available parts sources. Because we were changing the physical size of some of the parts, it meant that a new board would have to be laid out. That was to be my contribution to the project. The board was laid out and the new schematic drawn with Circad which is available for free on the Internet at

<http://www.holophase.com>. This is a demo version that is not crippled and is very useful for the average ham. You have the ability to printout circuit board patterns to a laser or inkjet printer with the demo version. About the only way the demo version differs from the full version is in the ability to generate Gerber files and PCX output. Holophase even has a special price for hams, \$295 vs. \$995 for non-hams. Contact them for details.

CIRCUIT DETAILS

W1FB did a great job describing the circuit, so we'll use his description from page 15 of QST, May 1976. For this part of the discussion, please refer to the schematic diagram contained on page 3 of this manual.

A look at the schematic will indicate that there's nobody at home, so to speak, in the two-stage circuit. A Pierce type of crystal

oscillator is used at Q1. Its output tickles the base of Q2 (lightly) with a few milliwatts of drive power, causing Q2 to develop approximately 450 milliwatts of dc input power as it is driven into the Class C mode. Power output was measured as 350 milliwatts (1/3 W), indicating an amplifier efficiency of 70 percent.

The collector circuit of Q1 is not tuned to resonance at 40 meters. L1 acts as a rf choke, and the 100 pF capacitor from the collector to ground is for feedback purposes only. Resonance is actually just below the 80 meter band. The choke value is not critical and could be as high in inductance as 1 mH, although the lower values will aid stability.



The collector impedance of Q2 is approximately 250 ohms at the power level specified. Therefore, T1 is used to step the value down to around 60 ohms (4:1 transformation) so that the pi network will contain practical values of L and C. The pi network is designed for low Q (loaded Q of 1) to assure ample bandwidth on 40 meters. This will eliminate the need for tuning controls. Since a pi network is a low-pass filter, harmonic energy is low at the transmitter output. The pi network is designed to transform 60 to 50 ohms.

L1 is made by unwinding a 10 uH Radio Shack choke (No. 273-101) and filling the form with No. 28 or 30 enamel covered wire. This provides an inductor of 24 uH. [Note: this part is no longer available from Radio Shack, so W6EMD subbed a 22 uH inductor

here.] In a like manner, unwind another 273-101 so that only 11 turns remain, (1.36 uH). The 11 turns are spaced 1 wire thickness apart. Final adjustment of this coil (L2) is done with the transmitter operating into a 50 ohm load. The coil turns are moved closer together or farther apart until maximum output is noted. [Again, this part is not available, so W6EMD subbed a toroid, T37-6 (yellow) with 21 turns of #26 wire.] The wire is then cemented into place by means of hobby glue or Q dope. Indications are that the core material is the Q1 variety (permeability of 125), which makes it suitable for use up to at least 14 MHz.

T1 is built by removing all but 50 turns from a Radio Shack No. 273-102 rf choke (100 uH). The ferrite core in this choke seems to be on the order of 950, in terms of permeability. This is good material for making broadband transformers, as very few wire turns are required for a specified amount of inductance, and the Q of the winding will be low (desirable). A secondary winding is added to the 50-turn inductor by placing 25 turns over it, using #22 or #24 enameled wire. The secondary is wound in the same rotation sense as the primary, then glued into position on the form. Tests with an RX meter show this to be a very good transformer at 7 MHz. There was no capacitive or inductive reactance evident. The primary winding has an inductance of 80 uH after modification. [Although the RS 273-102 is still available, W6EMD also replaced it with a toroidal transformer, as it just looked better and as long as you have to wind a toroid, you might as well wind two.]

Increased power can be had by making the emitter resistor of Q2 smaller in value. However, the collector current will rise if the resistor is decreased in value, and the transistor just might "go out for lunch," permanently, if too much collector current is allowed to flow. The current can be increased to 50 mA without need to worry, and this will elevate the power output to roughly 400 mW

CONSTRUCTION

Here are the steps to follow in putting your Tuna Tin 2 kit together.

1. Parts Inventory

Check out the contents of your kit to ensure that all parts are present. Put a little checkmark in the box next to each of the parts as you sort through the contents of the small plastic parts bag provided in your kit.

C1	.01uF (blue, "103")
C2	100 pF (marked "101")
C3	.01uF (blue, "103")
C4	250pF (marked "251")
C5	.01uF (blue, "103")
C6	390pF (marked "391")
C7	470pF (marked "471M")
C8	.1uF (small, orange, axial leads)
C9	22uF (electrolytic radial cap)
C10	.1uF (small, orange, axial leads)
C11	150pF (marked "151")
C12	.1uF (small, orange, axial leads)
L1	22uH choke (silver-red-red-black-silver)
L2	17T on T37-6 toroid core (yellow donut)
Q1	2N2222A transistor

Q2	2N2222A transistor
R1	4.7K (yellow-violet-red)
R2	47K (yellow-violet-orange)
R3	220 ohms (red-red-brown)
R4	100 ohms (brown-black-brown)
R5	1K (brown-black-red)
R6	8.2K (gray-red-red)
R7	56 ohm (green-blue-black)
T1	6 turns of bifilar-windings on FT37-43 toroid (black) (See text for winding.)
X1	crystal, 7.040MHz
J1	1/8" jack, mono, chassis mount
Magnet wire:	3' orange, 1' green
PCB	Printed Circuit Board

You will also need about 10" of thin gauge stranded hook up wire, and three more connectors (we suggest RCA phono jacks), and a SPDT toggle switch. We felt that these components would be somewhat subject to the builder's discretion, based on what enclosure you decided to use. So we left it up to you to get the parts. (A variety of jacks, switches and nice enclosures can be found at your local Radio Shack. Let us know if you have any problems in obtaining suitable parts.)

2. Start with the enclosure

This project was created from the start back in 1976 with a round circuit board designed to neatly fit just inside a small can of tuna obtained from your favorite grocery store. So naturally, we suggest using this method of "enclosing" your TT2 transmitter!

Start by getting your \$.39 can of tuna fish. Eat the contents (or otherwise get it out of the can!), clean it out, take the paper label off the outside, and *voila!* You have yourself an original enclosure for your TT2 kit!

We suggest that you do the metal work on your "chassis" before you start stuffing and soldering the parts on the board.

You could do as W1FB did back in '76 and mount the board to the bottom of the tuna can (i.e., the can is upside down, open end to the bottom). Use a nibbling tool to cut all but about 1/4" of the bottom out, leaving the 1/4" rim to solder to.

Alternatively, you could mount your board (as shown in the photo on page 1) on standoffs that are connected to the inside-bottom of the can. These standoffs hold the board up to the edge of the rim. You can then put rubber feet on the bottom of the can. You will need to drill 3 mounting holes in the board and then matching holes in the bottom of the tin using the board as a template. This mounting technique provides a completely enclosed project chassis.

After you drill the mounting holes in the base, you will need to drill the holes for 3 jacks and the SPDT toggle switch in the sides of the can. You can mount the switch directly opposite the middle connector, and mounted the three connectors on the same side of the can about 1 1/4" apart. See the Wiring Diagram the placement of the connectors and the switch.

Next wire the chassis as shown in the diagram and schematic. You can use pieces of stranded wire about 4" long to make the connections between the connectors and the board. (You'll have several wires "dangling" off the jacks and switch until you get the pc board prepared in the next section.)

Solder a wire to the outside shell terminals of each of the three jacks (J2, J3 and J4) mounted to the chassis. You can “daisy chain” a single wire to each jack. This is your ground system. Also connect a free wire from this daisy chained ground – this wire will remain dangling for now and will get soldered to the PCB ground plane in a later step.

Wire capacitor C9 between the center terminal of J4 (+13V) and the ground wire connecting the shells of all three jacks on the chassis.

3. Preparing the PCB

Okay, let’s start work on the round printed circuit board. You’ll first have to drill a ¼” hole to accommodate the connector supplied for your key jack. Make sure that it is mounted in the center of the rectangle shown for J1. This connector must be insulated from ground, as it is the means for applying power to the circuit. 13V is connected to one side of the jack. When the key is closed, the resulting short circuit connects the 13V to the circuit.

We’ll wire the jack and install the components on the PCB in the next section.

4. Installing the Components

You are now ready to install and solder the parts onto the printed circuit card. Refer to the parts list and the Layout diagram. The component layout is also silkscreened on the top of the PCB for your convenience. Be sure to check the schematic if you have any questions along the way regarding part orientation (like for polarity and such).

❑ **Installing Q1 and Q2 transistors.** First put the transistors into the holes for Q1 and Q2. These transistors have little tabs on their round metal case that denote the emitter lead (or “E” on the Layout diagram). Position the 3 leads of each transistor such that the tab is pointing toward the “E” on the board. Solder Q1 and Q2 in place and snip off the excess lead length from the bottom of the board

❑ **Installing the capacitors.** Next put all the caps in the proper locations, according to the numeric designation from the parts list. You should ensure that you have the correct capacitor, per the marking on the side of the component (391, 471, etc) as shown in the parts list. NOTE: C5 is not marked on the board, but is the component located just to the right of R7. Solder all capacitors in place and snip off excess lead length.

❑ **Installing the resistors.** You’ll have to be careful that you put the right one in the right location ... carefully inspect the color coding on the resistor body to ensure you have the right one. A bright light and a magnifying glass might be helpful. Sometimes the resistor will lie flat against the PCB, but other times the resistor will be mounted in an upright position, as shown below.



Once again, solder and snip the excess lead length.

❑ You should now **install the crystal** in the location marked X1. Solder and snip the leads.

❑ **Constructing the L2 toroid inductor.** This is a fun part of the project that some homebrewers worry about. There’s actually nothing very hard in winding a few turns of wire through the toroid core, and we’ll take you through it in a step-by-step manner.

Uncoil the supplied red magnet wire and cut off a 12” length, and begin winding the wire around the T37-6 toroid core (one side of this one is yellow.) Count one turn each time the wire is passed through the core. You will putting a total of 17 turns around the toroid core and Refer to the photo and figure below for guidance.

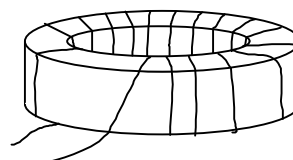
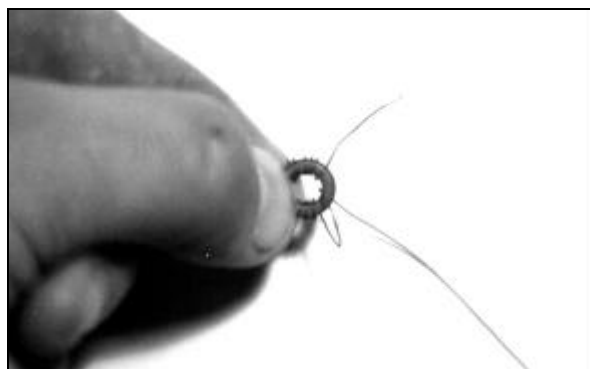

Once the wires of each inductor are trimmed roughly to the right length (extending about ½” from the body of the toroid, determined by temporarily inserting it on-end into position L2 on the board), scrape the enamel coating off tin the ends of the wires using an Exacto knife (or equivalent sharp blade). Be sure to get all the enamel off each end of the wire so you can solder the wires into the proper locations in the circuit board. Position L2 in the proper location on the board and orient as shown below. Gently pull each lead tight from the bottom of the board, bend the wire over the pad (to hold it in place) and solder the pad. 90% of most kit assembly problems come about because of improper scraping and soldering of toroid inductor leads, so please follow the instructions carefully in this section.

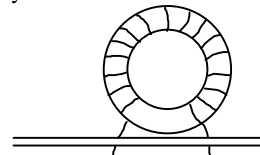

❑ **Constructing transformer T1.** This transformer is a “bifilar-wound” inductor on a toroid core, meaning that you’ll be combining two magnet wires together and winding them at the same time. Measure off a 9” length of red magnet wire, and another 9” length of green magnet wire. These wires should be twisted tightly together as illustrated below.

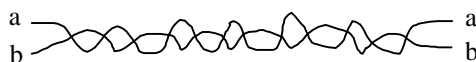

Suggestion: You can clamp the ends of the wires in a vise and use a twist drill to wind the length of the wires together. Alternatively, just grab the end of each in one hand and begin twisting the pair together with your right hand, ending up with an approximate length of 6”, twisted at about 5 turns per inch.

You will then wind the combined, twisted red and green wire pair around a FT37-43 toroid core (black/unpainted) in the same manner as previously described for L2. See the diagram below for proper connection of the four leads.

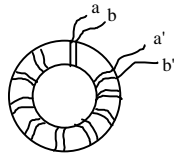

Diagram showing completed bifilar-wound transformer T1. (Note: 10 turns are shown here ... you will need only 6 turns)

Now, in the twisted pair you've just created, let's say that "a" is the red magnet wire and "b" is the green magnet wire. "a" is the start of the red wire and a' is the end. "b" is the start of the green wire and b' is the end. You need to twist wires a' (red) and b' (green) together to form the center tap.

Trim the leads to the correct length, scrape the enamel off each end like before, and install them onto the board as shown below.

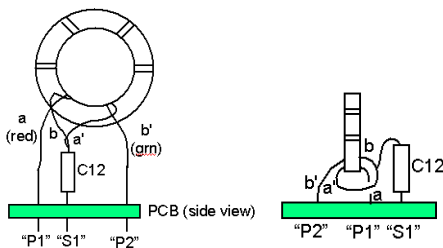

Diagram showing logical connection (on left), and physical connection (on right) for T1

As indicated above, you will need to have one end of capacitor C12 soldered into the board at the pad labeled "S1", and the other end of C12 sticking up in the air and connected to the center tap you just created a couple of paragraphs ago.

This T1 construction and mounting process is the trickiest part of the whole kit. But if you take your time and follow the instructions, you should end up with a success. Please let us know if you have any questions at all.

❑ **Wire up J1.** You next need to solder a wire from the pad labeled "To J1" on the PCB to one of the leads on the J1 jack in your PCB. Solder the wire on the bottom side of the indicated pad and put it to the "top-left" terminal of J1, as shown below.
[view of J1]

5. Putting it all together

Once all the components have been added to the PCB, you are ready to wire the board and the chassis together.

- ❑ Solder the wire which is dangling off J4 to the other terminal of J1 on the PCB. (Refer again to the close-up of J1 wiring.)
- ❑ Solder the wire which is dangling off the toggle switch to the pad on the PCB marked "To S1" (next to C10). This wire should be inserted and soldered from the bottom of the board.
- ❑ Solder the wire which is dangling off the daisy-chained ground wire to the pad on the PCB marked "To Ground" (next to C7). This wire should be inserted and soldered from the bottom of the board.

SMOKE TEST!

When you have finished, you are ready for the smoke test. Apply 12V power to the power connector, hook up a dummy load or 40 meter antenna to the rig, connect a key to the key jack, switch to transmit, and hit the key. You should hear a tone in a nearby receiver that is tuned to the frequency of your crystal.

During normal operation, you will have a 50-ohm antenna connected to J2. (You may need to use an ATU, or antenna tuning unit, to properly match your antenna to the 50-ohm output of the TT2 transmitter.) You will also need to have a separate receiver connected to the "Receiver" jack J3 on your TT2. When you are transmitting by keying the transmitter with a straight key plugged into J1 on the PCB, the toggle switch should be in the "Transmit" position that connects the antenna to the TT2 output stage. When you stop keying and want to listen to the reply, flip the toggle switch to "Receive" (which connects the antenna connector J2 directly to the receiver connector J3), you will be able to hear the person you are talking to. This is known as a manual "T-R"!

If you have trouble getting your rig to work, DeMaw even had a trouble shooting section to his original article that is repeated here from page 16, QST, May 1976.

The voltage shown in the schematic will be helpful in troubleshooting this rig. All dc measurements were made with a VTVM. The rf voltages were measured with an rf probe and a VTVM. The values may vary somewhat, depending on the exact characteristics of the transistors chosen. The points marked 1 and 2 (in circles) can be opened to permit insertion of a dc milliammeter. This will be useful in determining the dc input power level. Power output can be checked by means of an rf probe from J2 to ground. Measurements should be made with a 51 or a 56 ohm resistor as a dummy load. For 350 mW of output, there would be 4.4rms volts across the 56 ohm resistor.

Operating voltage for the transmitter can be obtained from nine Penlite (AA) cells connected in series (13.5 volts). For greater power reserve one can use size C or D cells wired in series. A small AC operated 12 or 13 volt regulated dc supply is suitable also, especially for home station work.

QUESTIONS?

If you have any problems with this Tuna Tin 2 kit, please let us know and we'll do what we can to help. Contact:

George Heron, N2APB
2419 Feather Mae Ct
Forest Hill, MD 21050
Email: n2apb@amsat.org

You can visit the NJ-QRP Club at their website at:

<http://www.njqrp.org>

and the NorCal QRP Club at their website at:

<http://www.fix.net/~jparker/norcal.html>

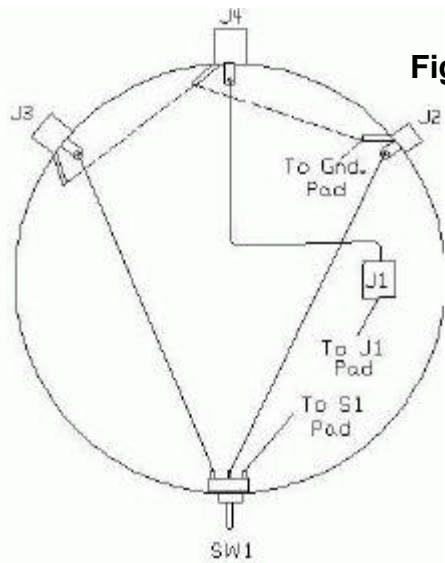

Figure 3: Wiring

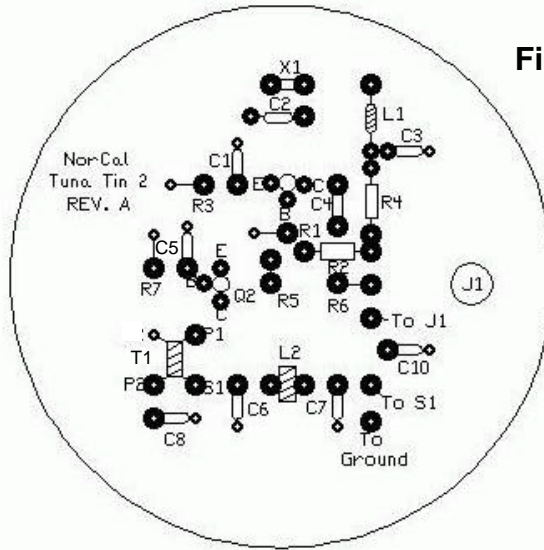

Figure 2: Layout

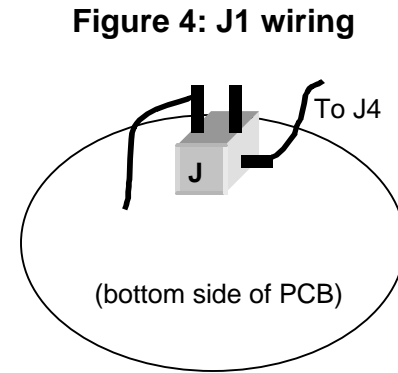
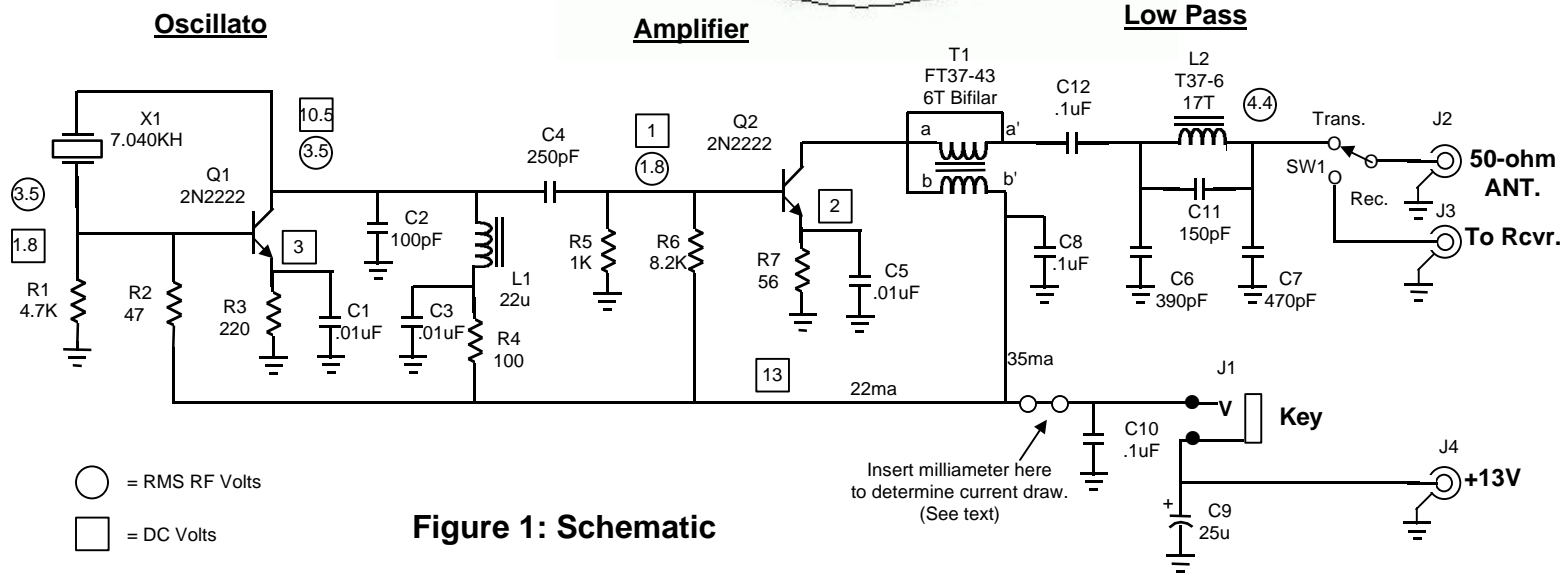

Figure 4: J1 wiring

(bottom side of PCB)



○ = RMS RF Volts
 □ = DC Volts

Figure 1: Schematic

Tuna Tin 2
 Designed by Doug Demaw, W1FB
 Updated parts by Dave Meacham, W6EMD
 Optimizations by Dave Fifield, AD6A
Kitted by the New Jersey QRP Club
 (with permission from NorCal QRP Club)

Tuna Tin 2 Transmitter

Designed by Doug Demaw, W1FB
Updated Parts by Dave Meacham, W6EMD

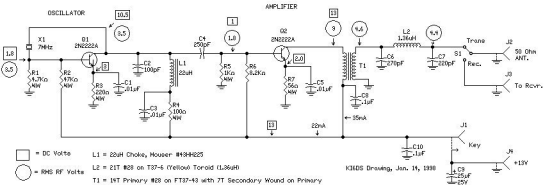

Useful Mods for your Tuna Tin 2 Kit

Here are a couple of simple modifications that you can make to your TT2 transmitter kit to make it better and easier to use. They include: (1) a cure for the chirp, (2) addition of a keyer chip, and (3) output power increase.

All mods are shown in the schematic on the next page.

Chirp Fix

The TT2 circuit has a tendency to "chirp" when keyed, as do many simple transmitter circuits. (A "chirp" is a small shift in frequency on each dit or dah as heard on the receiver, often due to the buffering used in these simple designs.) This chirp may be solved by adding a 2N3906 keying switch in the power line.

Basically the objective is to get the key out of the power circuit and put the 2N3906 in it - rather than your key acting as the on/off switch, the 2N3906 acts as the switch. You can use four components - R8 (1K ohm), R9 (470 ohm), C12 (0.1 uF), and Q3 (2N3906).

1. Disconnect the V+ from the key jack and remove C9.
2. Connect the V+ line to the emitter of the 2N3906.
3. Connect the collector of the 2N3906 to J1 where the power gets to the circuit.
4. Remove the line from the other terminal of the key jack.
5. Ground the key jack.
6. Connect R8 (1K ohm) to the "hot" terminal of the key jack - the one at the tip of the plug.
7. Connect the other end of R8 to the base of the 2N3906.
8. Run R9 (470 ohm) from the 2N3906's emitter to its base.

9. Run C12 (0.1 uF) from the 2N3906's collector to its base.

Adding a Keyer Chip

It is a piece of cake to add the popular Embedded Research "TiCK" keyer chip to the TT2 transmitter, thus allowing you to use paddles instead of a straight key. This turns a "novelty" TT2 transmitter into a "regular use" transmitter because it's so much easier to make lots of contacts, and to have longer QSOs using a paddle. See the simple circuit in the schematic on the next page - it ties in very conveniently with the 2N3906 mod above for the chirp. Just follow the schematic and you should have no problems.

The TiCK chip by Embedded Research is available from Bill Kelsey at **Kanga US, 3521 Spring Lake Dr., Findlay, OH 45840**
n8et@kangaus.com
Output Power Boost

You can increase the TT2 power output to about 250-400 mW by adding a 1K pot (one of those little board mounted pieces) in parallel with R7. You could gradually decrease Q2's emitter resistance until Q2 gets hot. Some of us have been able to turn the pot to minimum value with no heating of Q2. I now have about 12 ohms at Q2's emitter.

I hope this info is helpful. I've had a lot of fun with this little rig - have about 60 QSOs on it in the first month it was on the air.

NOTE: These TT2 application notes were originally published in QRP Homebrewer for Winter 2000, as submitted by Jake Carter, N4UY in Vienna, VA. You can email Jake at

Useful Mods for your Tuna Tin 2 Kit

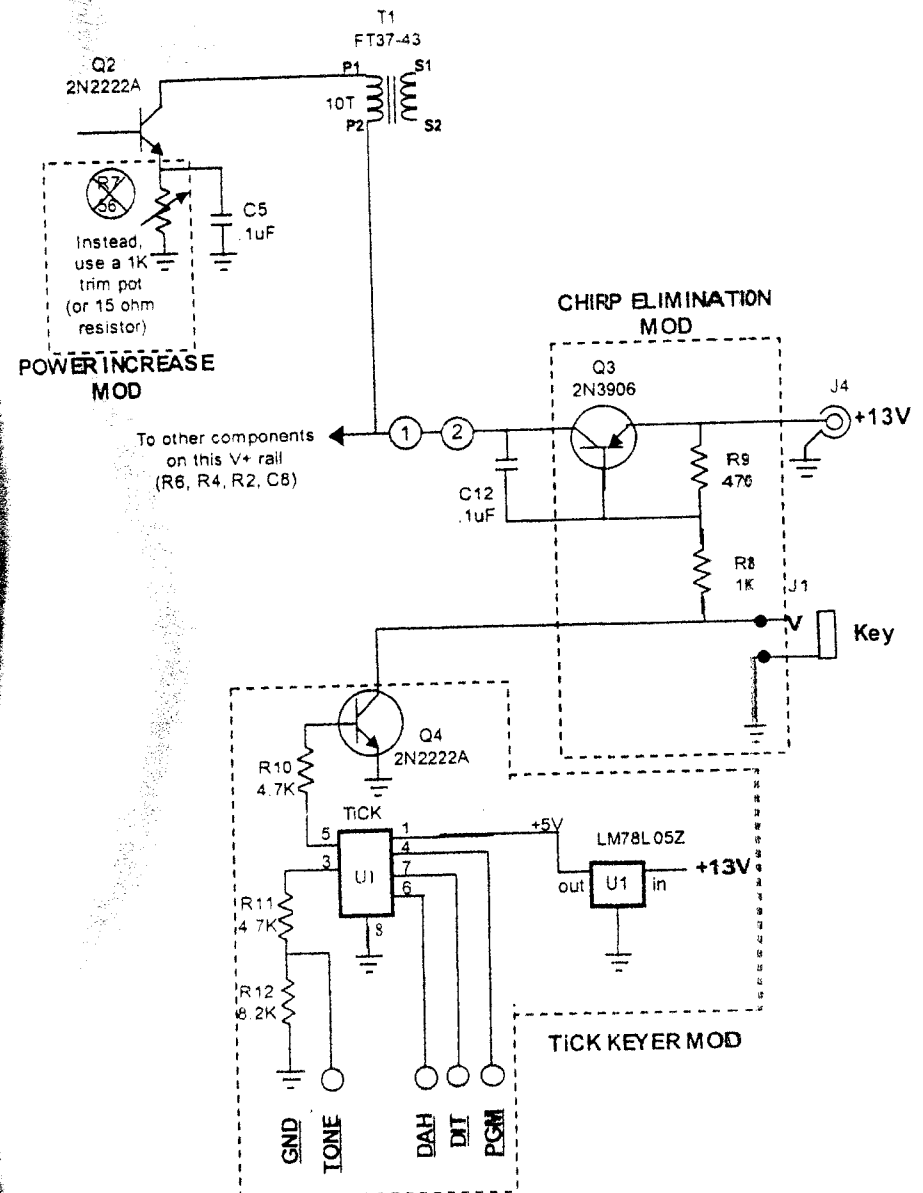

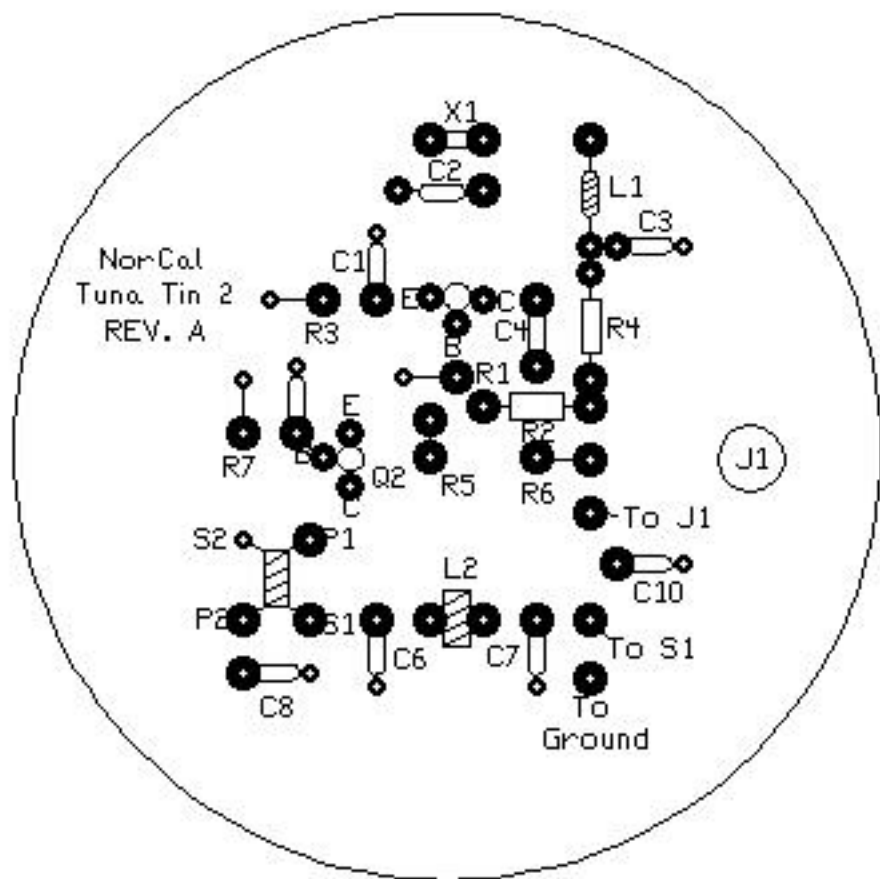

NorCal Updated Tuna Tin 2

Designed by: Doug DeMaw, W1FB

Updated by: Dave Meacham, W6EMD

Drawn by: Doug Hendricks, KI6DS/M0BIV

Date: Jan. 15, 1998 Sheet 1 of 1 Rev. A

