

YAESU

**OPERATING
MANUAL
FC-1000**

YAESU MUSEN CO., LTD.

1-20-2 Shimomaruko, Ota-Ku, Tokyo 146, Japan

YAESU U.S.A.

17210 Edwards Rd., Cerritos, CA 90703, U.S.A.

YAESU INTERNATIONAL DIVISION, (Caribbean, Mexico, Central & So. America)
7270 NW 12th St., Suite 320, Miami, FL 33126, U.S.A.

YAESU EUROPE B.V.

Snipweg 3, 1118DN Schiphol, The Netherlands

YAESU UK LTD.

Unit 2, Maple Grove Business Centre,
Lawrence Rd., Hounslow, Middlesex, TW4 6DR, U.K.

YAESU GERMANY GmbH

Am Kronberger Hang 2, D-65824 Schwalbach, Germany

YAESU HK LTD.

11th Floor Tsim Sha Tsui Centre, 66 Mody Rd.,
Tsim Sha Tsui East, Kowloon, Hong Kong

Contents

Specifications	2
Supplied Accessories	2
Controls & Connectors	3
Controller Unit Front Panel	3
Controller Unit Rear Panel	4
Tuner Unit (Internal)	5
Installation	6
Antenna	6
Tuner Unit Cable Connections	6
Mounting the Tuner Unit	7
Mounting the Controller Unit	9
Interconnections	10
Operation	12
Calibration	12
Beginning Operation	12
Matching Procedure	12
Band Chart for FT-7x7GX & FT-80C	13
Receive-Only Operation	13
In Case of Mismatch	14
Control Unit Block Diagram	17
Tuner Unit Block Diagram	17
Control Unit Circuit Diagram	18
Tuner Unit Circuit Diagram	20

FC-1000 HF All Band Automatic Antenna Tuner

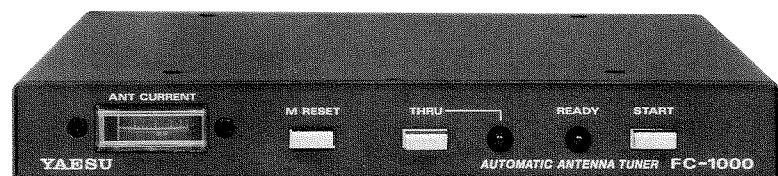
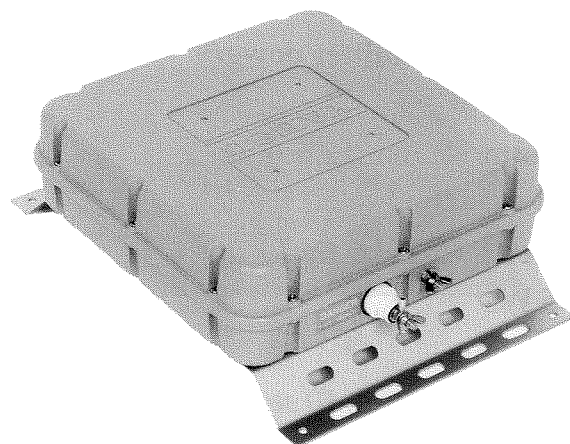

The FC-1000 is a two-unit microprocessor-controlled antenna matching system designed to optimize performance with transceivers operating in the range of 1.8 to 30 MHz with up to 150-W PEP output, these are the radios; Yaesu FT-80C, FT-747GX, FT-757GX(II), and FT-767GX.

The Controller Unit installs with the transceiver so the operator can control and monitor automatic operation of the Tuner Unit, mounted at the antenna feed point. The Tuner Unit uses special thermally stable components and is housed in a waterproof casing to reliably withstand severe climatic extremes.

A carefully chosen combination of solid-state switching components and high-speed relays allows the FC-1000 to match a wide variety of antennas to within a 1.5:1 SWR on any HF frequency in typically 3 seconds. To

minimize interference and protect the equipment, transmitter power is automatically reduced to 12.5 watts while the antenna is being matched, and matching settings are automatically stored in memory for instant recall when the same channel or band is reselected later.

This manual describes all of the controls and connectors of the FC-1000, plus how it should be installed and connected with various types of antennas and transceivers. The *Operation* section describes calibration of the tuner before initial operation. For commercial applications, the calibration section is intended for the installing technician and technical support staff, and may be ignored by the operator.

Once installed and calibrated, the operator only needs to push the **START** button when changing channels (or bands).

Specifications

Operating frequency range

1.8 ~ 30 MHz w/12 m+ random wire

Matching impedance

50 ohms (unbalanced)

Maximum transmitter power

150-W PEP

Maximum SWR after tuning

1.5:1 or better

Required RF power for tuning

12.5 W

Tuning time

3 seconds typical, 10 seconds maximum

Memories

up to 32 (depending on transceiver)

DC supply voltage

13.5-V DC $\pm 15\%$

Current consumption

1.5 A maximum

Operating temperature range

-30 to +65°C (-22 to +149°F)

Case size (WHD)

Controller Unit: 238 × 31 × 236 mm

Tuner Unit: 264 × 80 × 264 mm

Weight

Controller Unit: 1.4 kg

Tuner Unit: 2.1 kg

Specifications may be subject to change without notice or obligation.

Supplied Accessories

Model & Description (Quantity/Size)

Order Number

Cables

E-1000D(DC) DC Power Cable (3m, fused)	T9016802
GND Cable (Controller-to-Transceiver, 0.7 m)	T9100852
RF IN Short Coaxial Cable (0.65 m)	T9100160A
RF OUT Long Coaxial Cable (10 m)	T9101367
Tuner Unit Control Cable, 4-wire (10 m)	T9101370D
E-1000A BAND DATA Cable for FT-757GX(II) (0.65 m)	D4000032
E-1000B BAND DATA Cable for FT-747GX/-767GX (0.65 m)	D4000033
E-1000E TRANSCEIVER Cable for FT-7x7 series (0.65 m)	D4000034

Miscellaneous Hardware

Machine Screws, Nuts & Washers (set)	C3910004
U-bolt Kit U-65	D8000233
Spare Fuses 2-A (2)	Q0000003
Bushing Collar NA-310 (4)	S6000134
Bushing NA-300 (4)	S6000135
Binding Head Screw M3 × 20 (4)	U20320001
Toroidal Core 3A4 TRA40 Pack	L9190075

Controls & Connectors

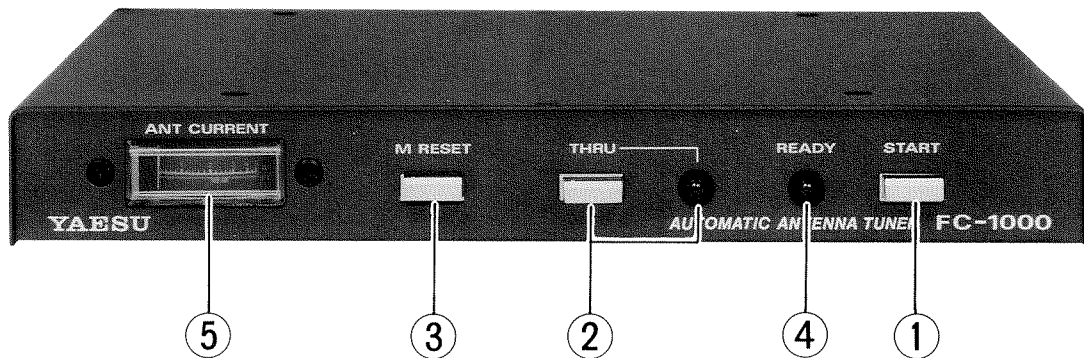

Controller Unit Front Panel

(1) **START** Button

Press this button to start antenna matching, or to select prestored tuner settings for the selected operating channel (as described in the *Operation* section).

(2) **THRU** Button & Indicator Lamp

Press this button to bypass the tuner. The lamp lights when the tuner is bypassed. If this indicator blinks, a problem is indicated in the antenna system or Tuner Unit.

(3) **M RESET** Button

Press this button to erase prestored tuner settings for the selected operating channel as described in the *Operation* section.

(4) **READY** Green Indicator Lamp

This lamp blinks during automatic antenna matching, and then stays lit when tuning is

completed. If the antenna cannot be matched, this indicator and the **THRU** Indicator blink at the same time during transmitting.

(5) **ANT CURRENT** Meter

Use the lower (green) scale when calibrating the FC-1000, to set the power level to be used during matching to 12.5 watts (see the diagram below). During automatic antenna matching, the meter indicates relative forward power of the transmitter carrier. After matching, the meter shows antenna current (5-A full scale).

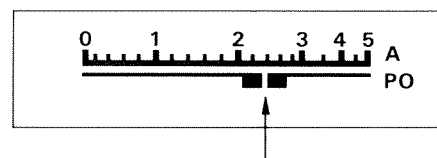

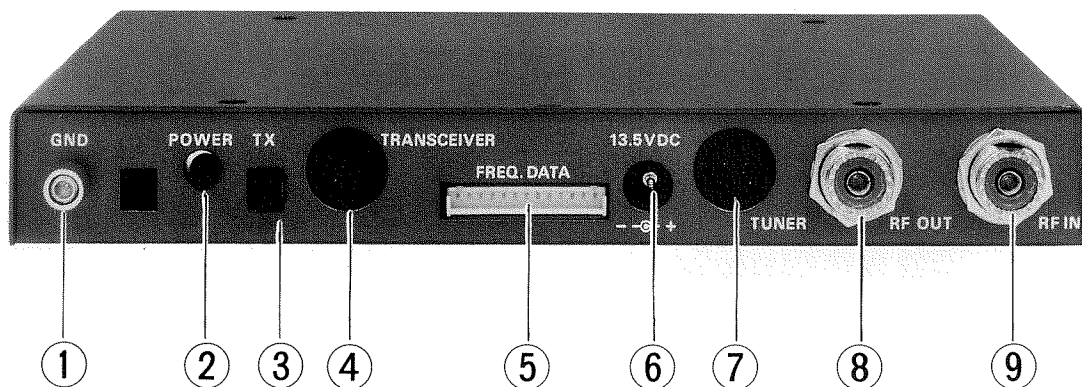

Controller Unit Rear Panel

(1) **GND** Terminal Post

This post connects to the radio through the supplied grounding cable, and to a good earth ground (or chassis ground in mobile installations), using heavy braided cable.

(2) **POWER** Control

This control sets the power level used for matching (approximately 12.5 watts).

(3) **TX** Button

This button activates the transmitter when setting the power level with the **POWER** control.

(4) **TRANSCEIVER** Jack

One cable from the transceiver connects to this jack, providing power to the Controller Unit and transmitter control signals back to the transceiver.

(5) **FREQ. DATA** Jack

This jack accepts digital band or channel selection data from the transceiver through another supplied cable.

(6) **13.5VDC** Coaxial Power Jack

This jack requires a 13.5-V, 1.5-A DC power source to power the Tuner Unit.

(7) **TUNER** Jack

The Tuner Unit connects to this jack using the supplied Tuner Control Cable.

(8) **RF OUT** Coaxial Jack

The Tuner Unit also connects to this jack using the supplied long coaxial feed line.

(9) **RF IN** Coaxial Jack

The **ANT** jack on the transceiver connects to this jack using the supplied short coaxial cable.

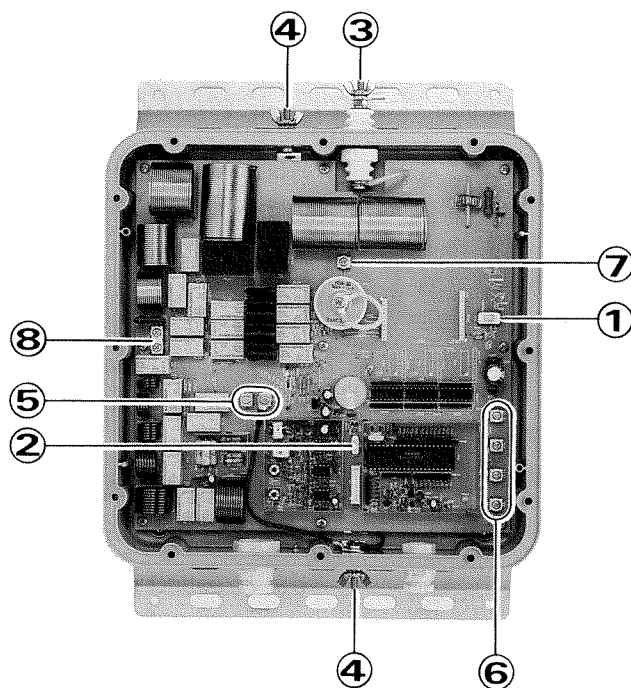

Tuner Unit (Internal)

Most of these switches and connection terminals are inside the Tuner Unit, and are accessible only when the cover is removed for initial installation or servicing.

(1) PRESET Slide Switch

Keep this switch in the ON position when servicing the Tuner Unit (not normally used by the operator).

(2) S01 Slide Switch

This switches the memory backup battery on and off. It should be ON except when necessary during servicing.

(3) Antenna Terminal Post

The antenna must always be connected here during operation.

(4) Ground Terminal Posts (2)

Connect a good earth ground through the shortest possible path to this terminal (lower terminal preferred). Carefully note the drawings on page 6.

(5) Coaxial Cable Terminals (2)

The coaxial feed line to the **RF IN** Jack on the Controller Unit connects to these terminals as shown above (center conductor to J01, braid to J02).

(6) Control Cable Terminals (4)

The 4-conductor cable from the Controller Unit connects to these terminals as follows:

Terminal	Color	Signal
J04	WHITE	METER
J05	RED	DATA
J06	BLUE	+13.5-V
J07	BLACK	GND

(7) Capacitance Tap (Terminals J10, JP01, C51)

This tap may be used to add 50-pF capacitor C51 in parallel with the antenna, if necessary to obtain a proper match (see *In Case of Mismatch* on page 14).

(8) Terminals J11& J12, and Strap JP02

The strap is normally installed at the factory, but may be removed if necessary to obtain a proper match (see *In Case of Mismatch* on page 14).

Installation

Antenna

The FC-1000 can match a wide range of antennas over the HF spectrum. For base operation we recommend a single wire antenna. Refer to the table below for minimum recommended wire lengths. If the antenna is less than $\frac{1}{4}$ wavelength or a multiple of a $\frac{1}{2}$ wavelength on any operating frequency, matching problems can occur. In this case, you may need to change jumper settings in the Tuner Unit as described in *In Case of Mismatch* on page 13, and repeat the matching procedure. If this still fails to provide an adequate match, the antenna *must* be modified, regardless of length.

Operating Frequency Range	Minimum Recommended Antenna Length (m)
1.8 - 30 MHz	12 m
3.5 - 30 MHz	6 m
7.0 - 30 MHz	3 m

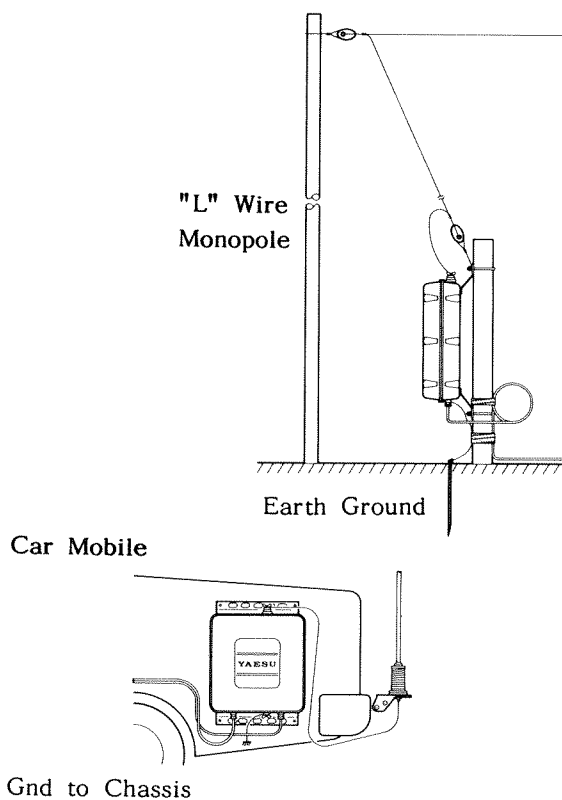

Tuner Unit Cable Connections

- Remove the 12 screws in the cover of the Tuner Unit, and remove it.
- Set switch S01 to the ON position.
- Install the toroidal RF choke approximately 30 ~ 50 cm from the Tuner Unit by inserting both cables through the toroidal RF choke *twice*, forming a loop as shown on the facing page .
- Slide the supplied cap nut and packing over the dressed end of the coaxial feed line, as shown on the next page, and then install the cable through the leftmost hole in the bottom edge of the Tuner Unit.
- Connect the center conductor of the coaxial feed line to J01 in the Tuner Unit, and the shield braid to J02. Tighten the screw terminals, and then tighten the cap nut to secure the cable.
- Repeat the last two steps with the 4-wire control cable, connecting the four terminated wires as shown below. Leave a little slack in the cable inside the Tuner when tightening the cap nut.
- Replace the cover and tighten the 12 screws firmly.

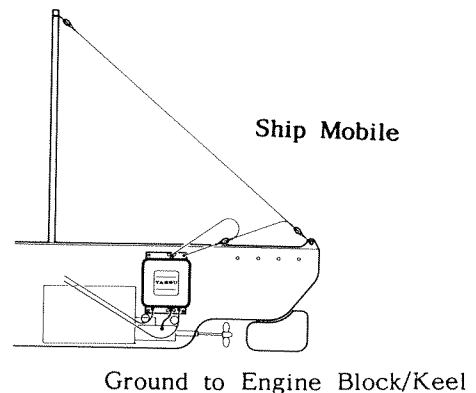

Mounting the Tuner Unit

The antenna type and station location determine the mounting method for the Tuner Unit. In all installations, however, the Tuner Unit must be located at the intended feed point for the antenna. The drawings on the next page show three examples of placement of the tuner in typical mounting locations. Following are several important considerations to remember during installation:

- Orient the Tuner Unit with the cables extruding downward (to minimize the chance of water leakage through the cable holes).

- The grounding wire and the length of antenna wire between the tuner terminal and the nearest antenna support should be *as short as possible*.
- The antenna must not touch anything except supporting insulators.
- To avoid straining the cables at the Tuner Unit, support them near the Tuner Unit.

For base stations, mount the Tuner Unit on either a flat surface such as the wooden board shown in Figure 1, or on a 55 ~ 65-mm diameter mast using the supplied U bolts as shown in Figure 2.

For mobile installations, mount the Tuner Unit to a flat surface using either bolts or self-tapping screws (Figure 3) inside the trunk or cabin, as close to the base of the antenna as possible. It can be mounted horizontally if well protected from the weather.

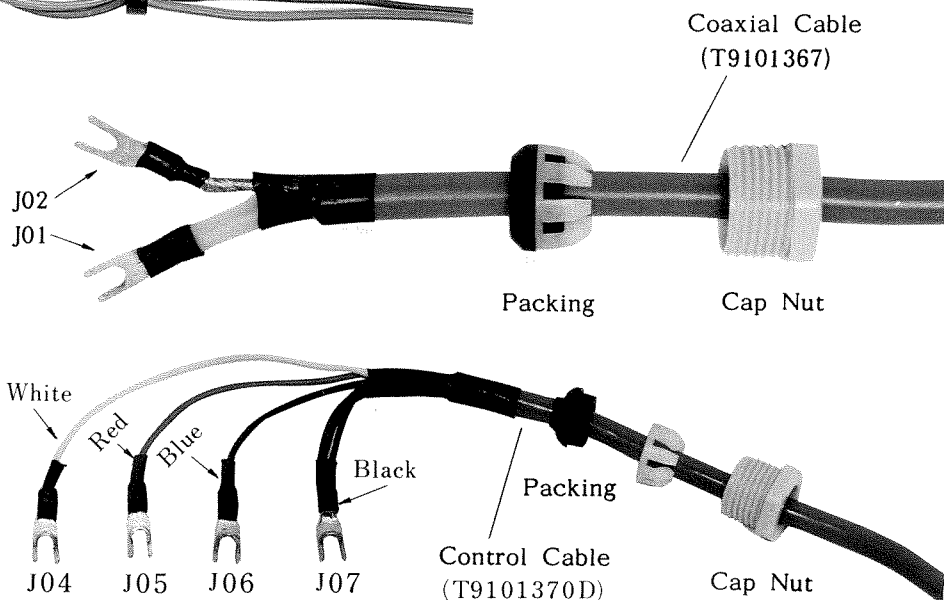
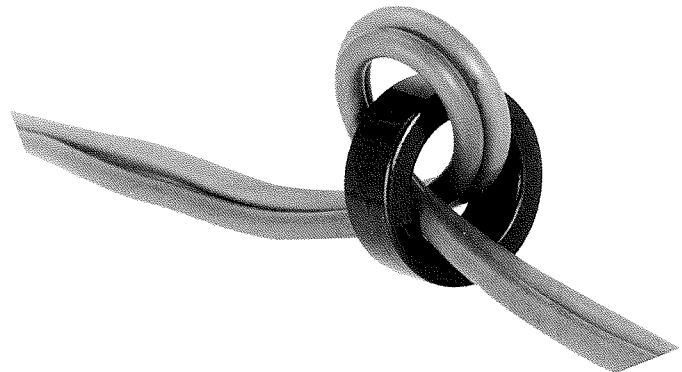
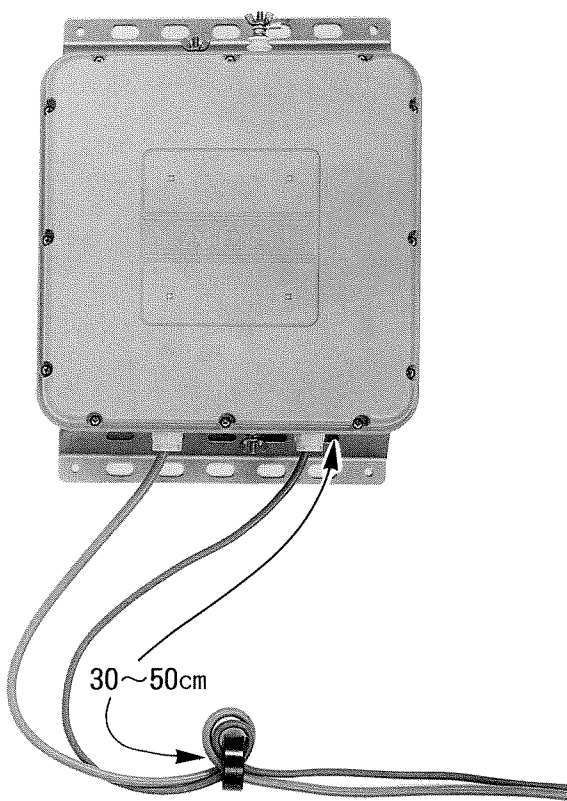

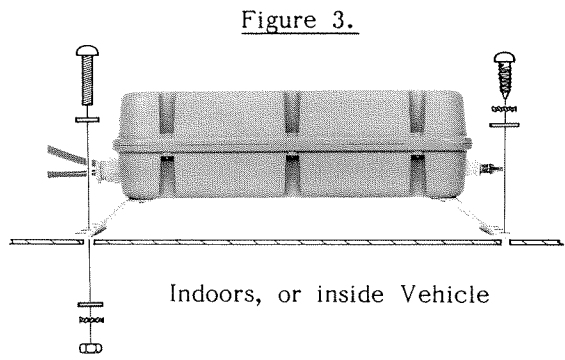
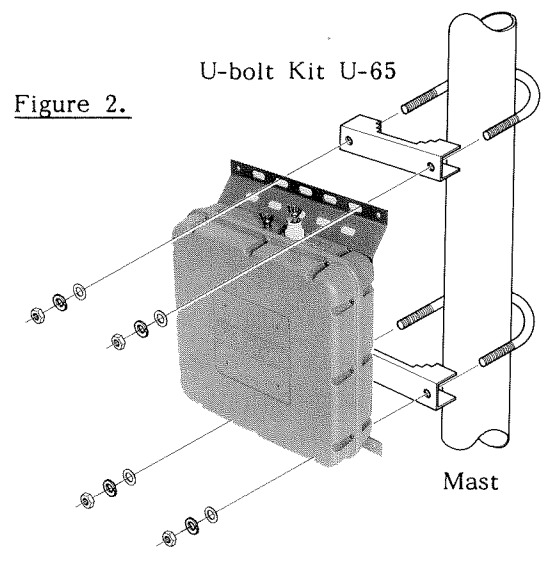
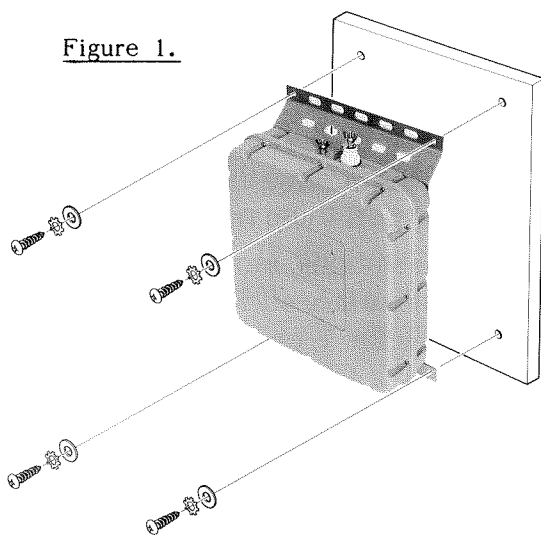

Important!

The FC-1000 is provided with two ventilation holes, plugged with self-tapping screws and rubber packing grommets. At the time of installation, one (and only one) of these screws should be removed to prevent condensation on the high-voltage parts during operation. The correct screw to remove is the one which will be on the bottom of the FC-1000 in its final mounting position.

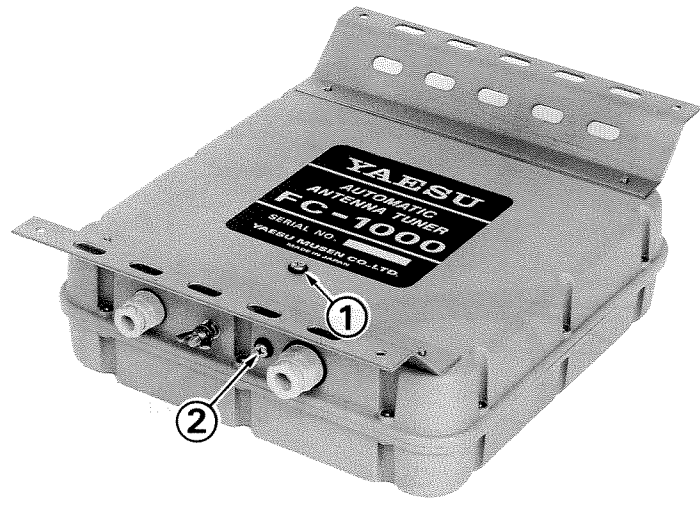

Mounting the Controller Unit

The Controller should be near the transceiver for operator convenience.

For base or mobile installations, the Controller Unit can be attached to the bottom of the FT-757GX(II) using the four supplied bolts and spacers as shown below. Remove the feet on the bottom of the FT-757GX(II) and the top cover of the Controller Unit to install the screws.

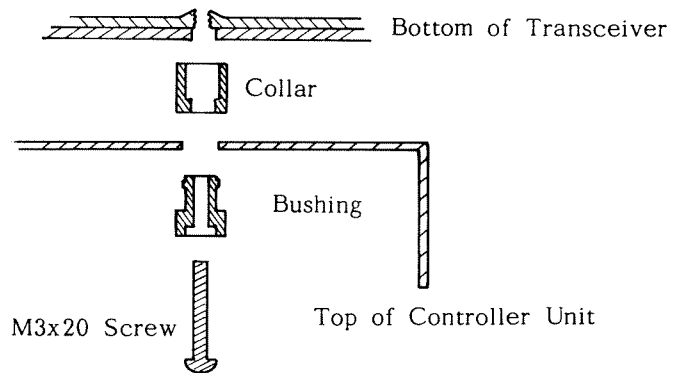
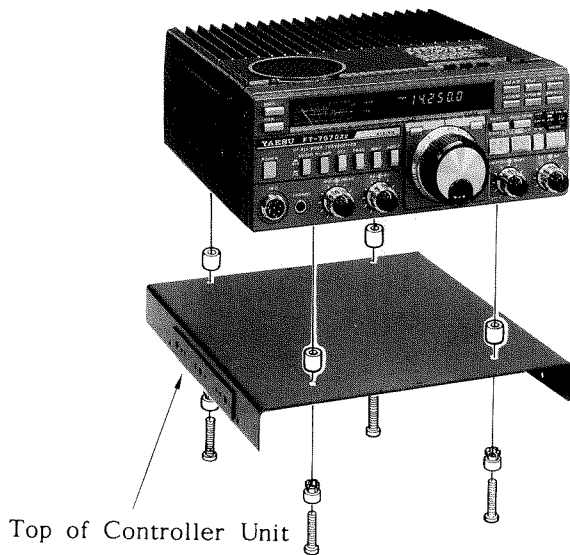

Interconnections

Controller Unit connections with the Tuner Unit are straightforward, but transceiver interconnections depend upon the model, as indicated in the diagrams here and on the next page.

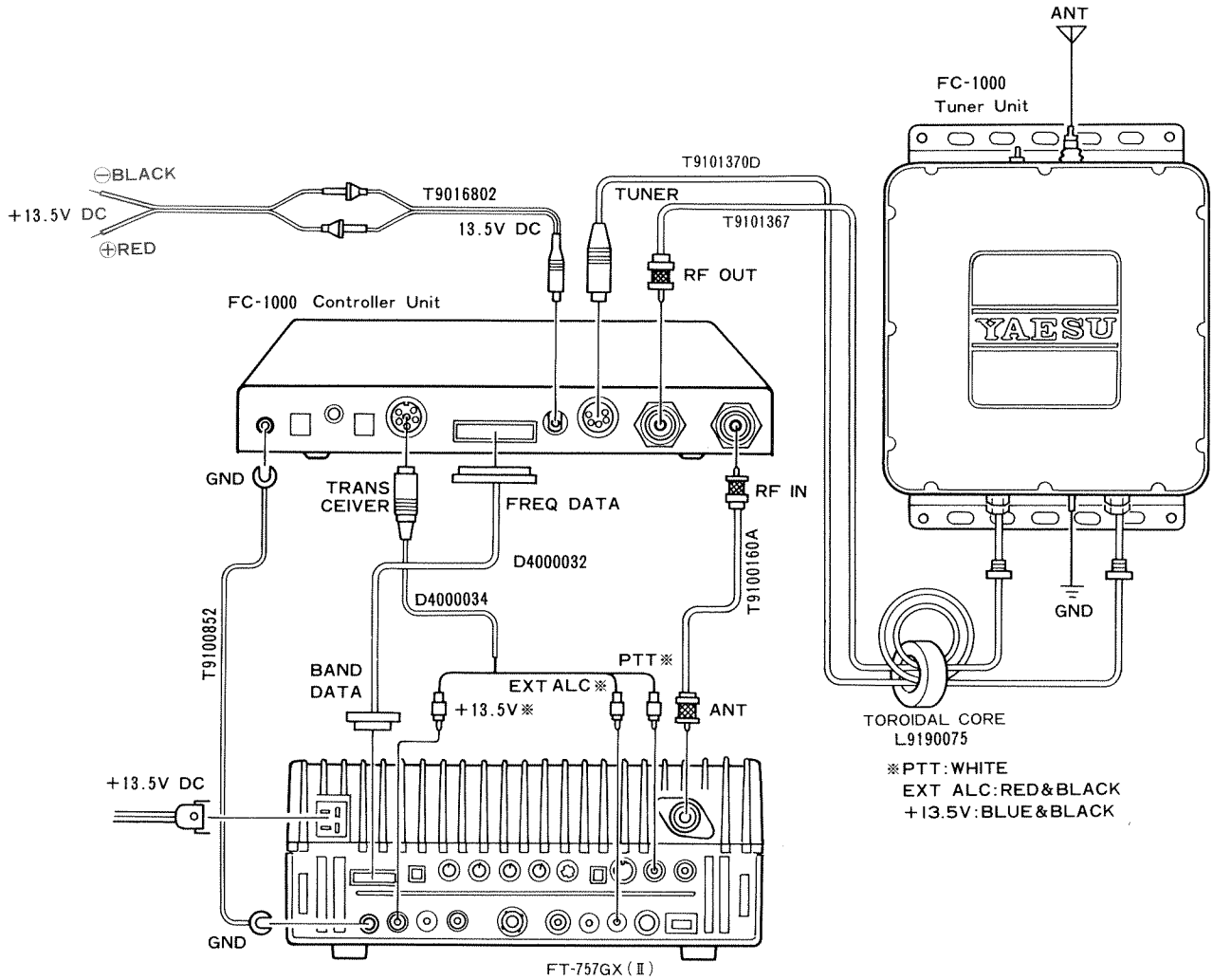

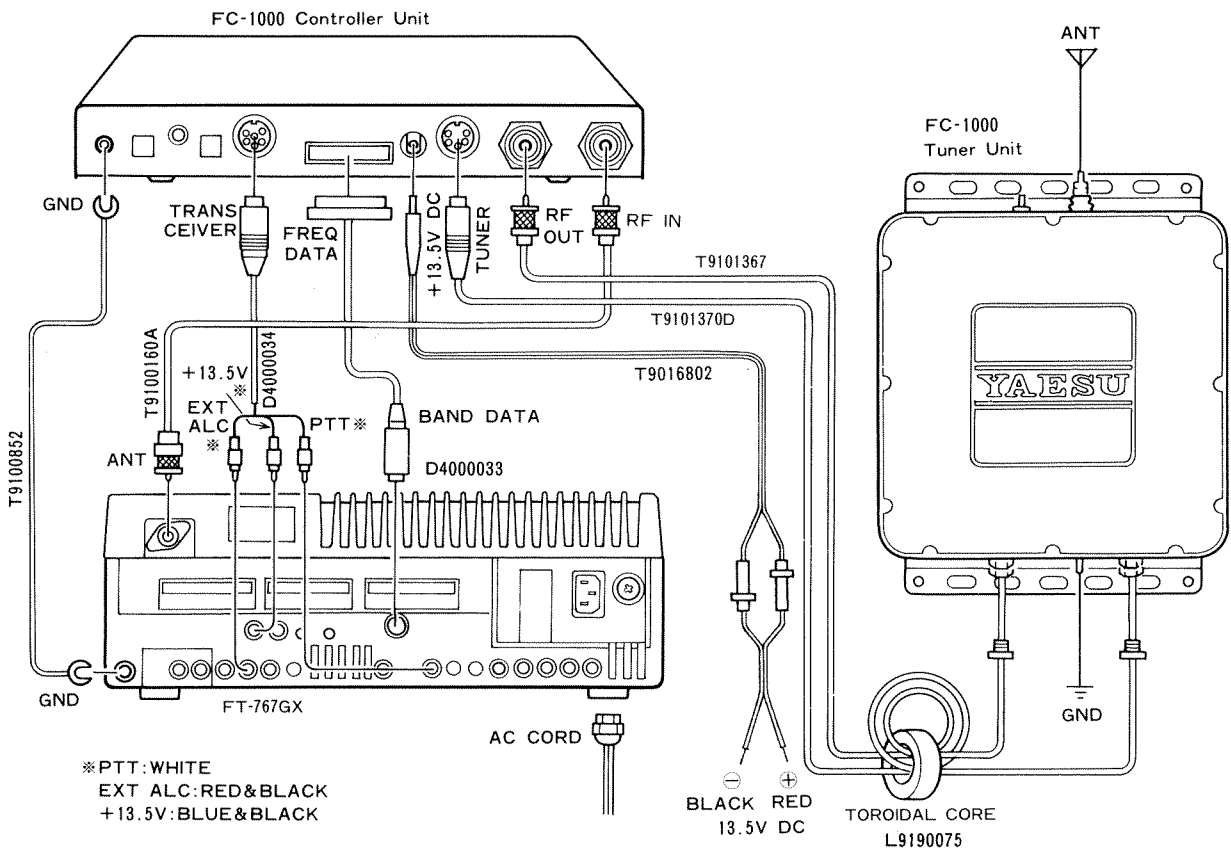
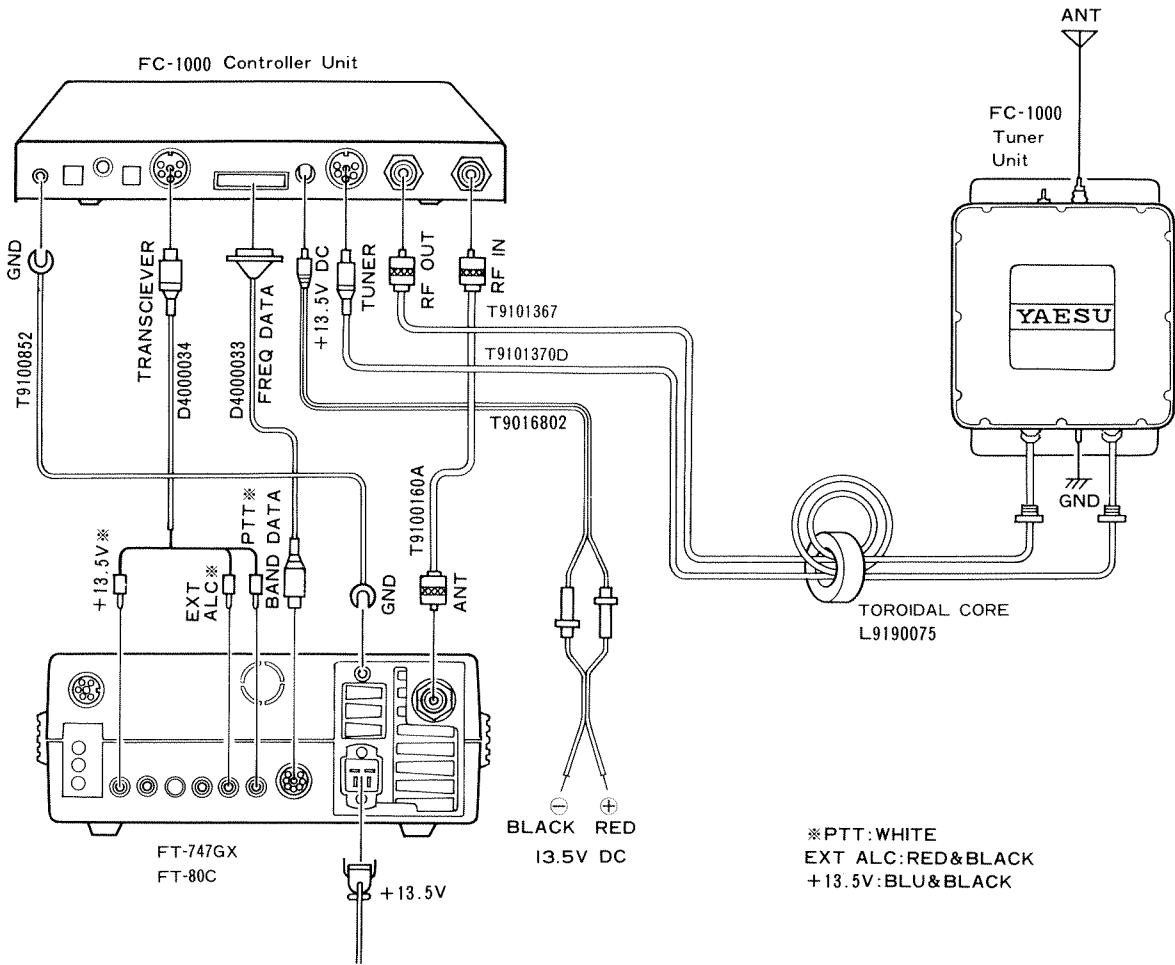

Operation

The FC-1000 must be installed before operation. After the FC-1000 has been installed, or if the transceiver is replaced, the Controller Unit must be calibrated so that transmitter power is restricted (by the Controller Unit) to 12.5 watts during antenna matching. After calibration, no further adjustment is necessary. If using the FC-1000 with the FT-767GX, turn the internal antenna tuner off.

Calibration

Make certain that the antenna is connected to the Tuner Unit, and that the Tuner Unit is connected to the Controller Unit (two cables).

- With the transceiver switched on, select AM or CW mode. If you intend to operate through the entire 1.8–30 MHz spectrum, select a frequency within the 7–14 MHz range, otherwise choose your most frequently used channel or transmitting frequency.
- If the transceiver has a **DRIVE** control, set it fully clockwise (maximum).
- Set the **POWER** control on the rear panel of the FC-1000 Controller Unit fully counter-clockwise (minimum, when viewed from the rear).

If a 50- Ω dummy load is available, connect it to the **RF OUT** jack on the rear of the Controller Unit in place of the Tuner Unit cable, and skip the next three steps.

- Press the **START** button and observe the lamps: **READY** should blink a few times, and then **THRU** turn on.
- Turn the **POWER** control (on the rear) slightly clockwise, wait until the channel is clear, and press **START** again.
- If necessary, repeat the previous step several times, until **THRU** no longer lights, but **READY** stays on (after blinking).
- Press the **TX** button on the rear of the Controller, and adjust the **POWER** control while

watching the meter, so that it indicates as shown here:

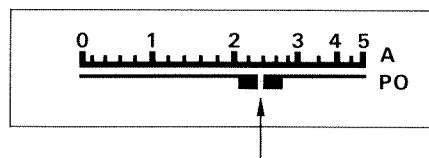

- Press the **TX** button again (to turn it off).

If you used a dummy load, disconnect it and reconnect the Tuner Unit coax to the **RF OUT** jack.

Beginning Operation

When beginning operation for the first time after initial calibration, the FC-1000 memories are *empty*. After the matching procedure is performed, they will be filled with memorized settings.

Matching Procedure

Select AM, FM or CW mode, and set the drive control for *maximum*. Listen to make sure the frequency is clear, then press **START** to activate the FC-1000. The transmitter will be activated (with about 12.5-W output) by the FC-1000. The **READY** lamp will blink a few times, and then stay on if a match is found. Otherwise, if the tuner is unable to match the antenna at the operating frequency, the **THRU** lamp comes on, indicating the tuner is bypassed.

Caution!

High voltage may be present at the antenna terminal of the FC-1000 when transmitting. Make certain that no person or animal comes into contact with this terminal or the antenna.

After a successful match, the proper tuner settings are stored automatically in memory. Later, whenever you change bands, press

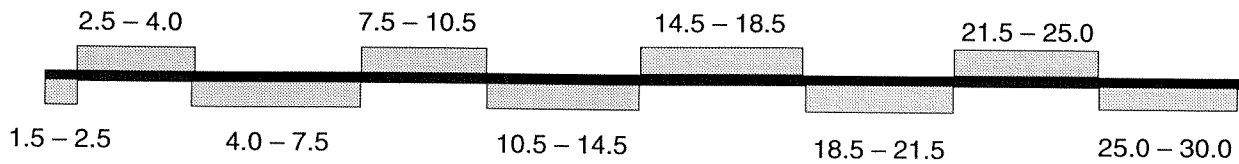

Band Chart For FT-7x7GX & FT-80C (MHz)

START to recall the memorized settings for that band (transmitting is not necessary).

If a suitable match is not obtained on the first attempt, retry tuning by pressing the **START** button again. (A mismatch can occur if the end-fed antenna is a multiple of $\frac{1}{2}$ wavelength at the operating frequency OR if the antenna is too short.) . If this still fails to provide an adequate match, the antenna must be modified or see *In Case of Mismatch* on the next page.

If your operating frequency is different from the one you used when previously storing the tuner settings, you may want to re-match the antenna. To do this, press **M RESET** and repeat the matching procedure.

During the antenna matching process, the tuner attempts to find a match resulting in the lowest possible SWR. If an SWR of $\leq 1.5:1$ is obtained, the tuner setting is then *automatically* memorized for that channel/frequency band. However, if the resulting match is between $1.5:1 \sim 2.0:1$, the tuner settings are *not* memorized (operation is still possible). Whenever returning to this channel/frequency, re-

tuning is necessary. If a match of $\leq 2.0:1$ cannot be obtained, the tuner is bypassed.

Receive-Only Operation

For the FC-1000 to match the antenna it is necessary to transmit. However, you should only transmit on authorized frequencies. Therefore, to listen to frequencies outside of authorized bands, do not press **START**, but rather press the **THRU** button to bypass the tuner circuitry. The FC-1000 acts like a high-pass filter, so frequencies below that for which the tuner has been matched will be attenuated unless it is bypassed.

Although the maximum power rating of the FC-1000 is 150 watts PEP, the tuner may over-heat in continuous-carrier modes such as FM and RTTY . When transmitting in these modes, reduce output power to 30 to 50 watts to protect the FC-1000.

The **READY** and **THRU** lamps indicate tuning status. Refer to the following chart if necessary to confirm Controller Unit indications.

With any transceiver, transmitting without first pressing **START** will prevent the tuner from recalling the prestored settings, and both **THRU** and **READY** lamps will blink if the antenna is mismatched.

READY Indicator	THRU Indicator	TUNER CONDITION
Blinks	Off	Antenna matching in progress
Lit	Off	Matching is complete <i>or</i> memorized setting selected
Off	Lit	SWR $\geq 2.0:1$, Tuner Unit bypassed
Off	Blinks	Tuner Unit \leftrightarrow Controller Unit communications problem. Check Tuner Control Cable
Blinks	Blinks	Both blink if transmitting into mismatched antenna. Check antenna and/or RF cable

In Case Of Mismatch

If the tuner cannot find a match, you will need to open the Tuner Unit and change jumper settings. The table below shows the steps to follow according to antenna conditions. From the factory, JP01 (C51) is disconnected, and JP02 is connected.

CONDITION	JP01 (C51)	JP02
Antenna too short ($< 1/4 \lambda$)	connect	connect
Antenna too long ($l > 1/4 \lambda$)	disconnect	disconnect

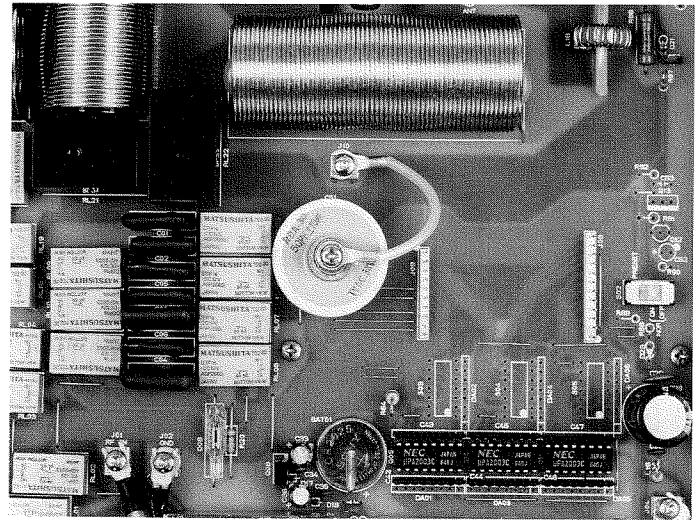

Note

Note

CONTROL UNIT BLOCK DIAGRAM

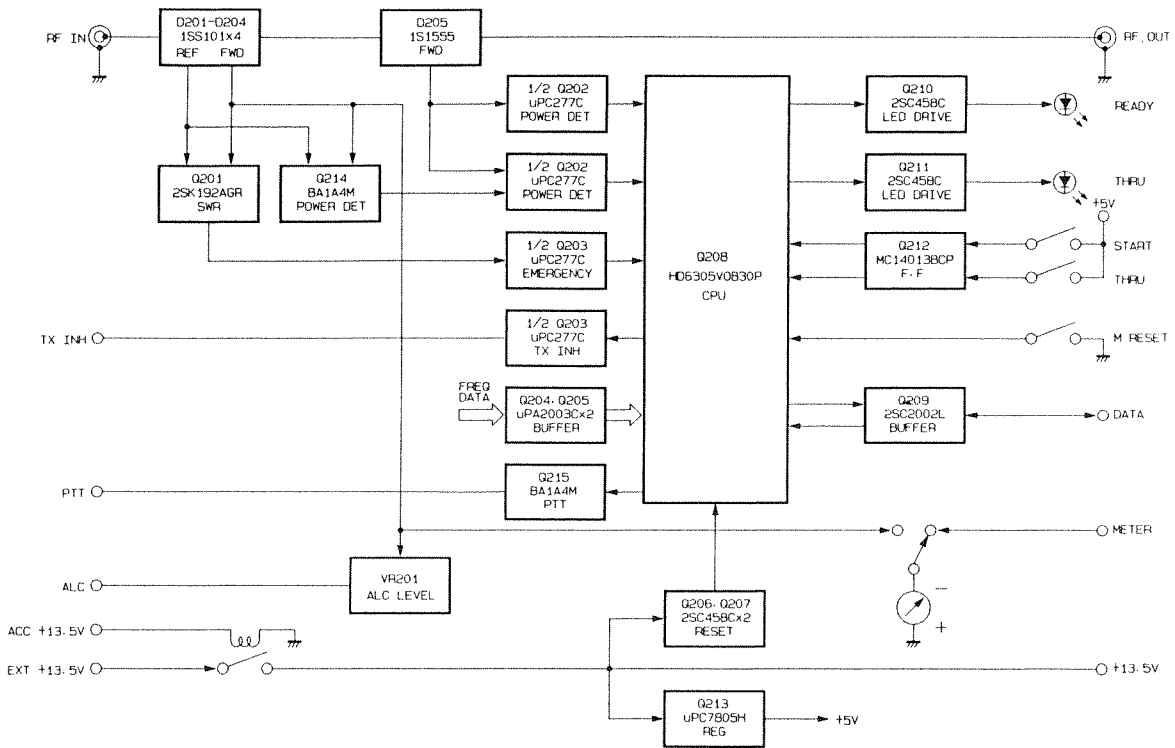

TUNER UNIT BLOCK DIAGRAM

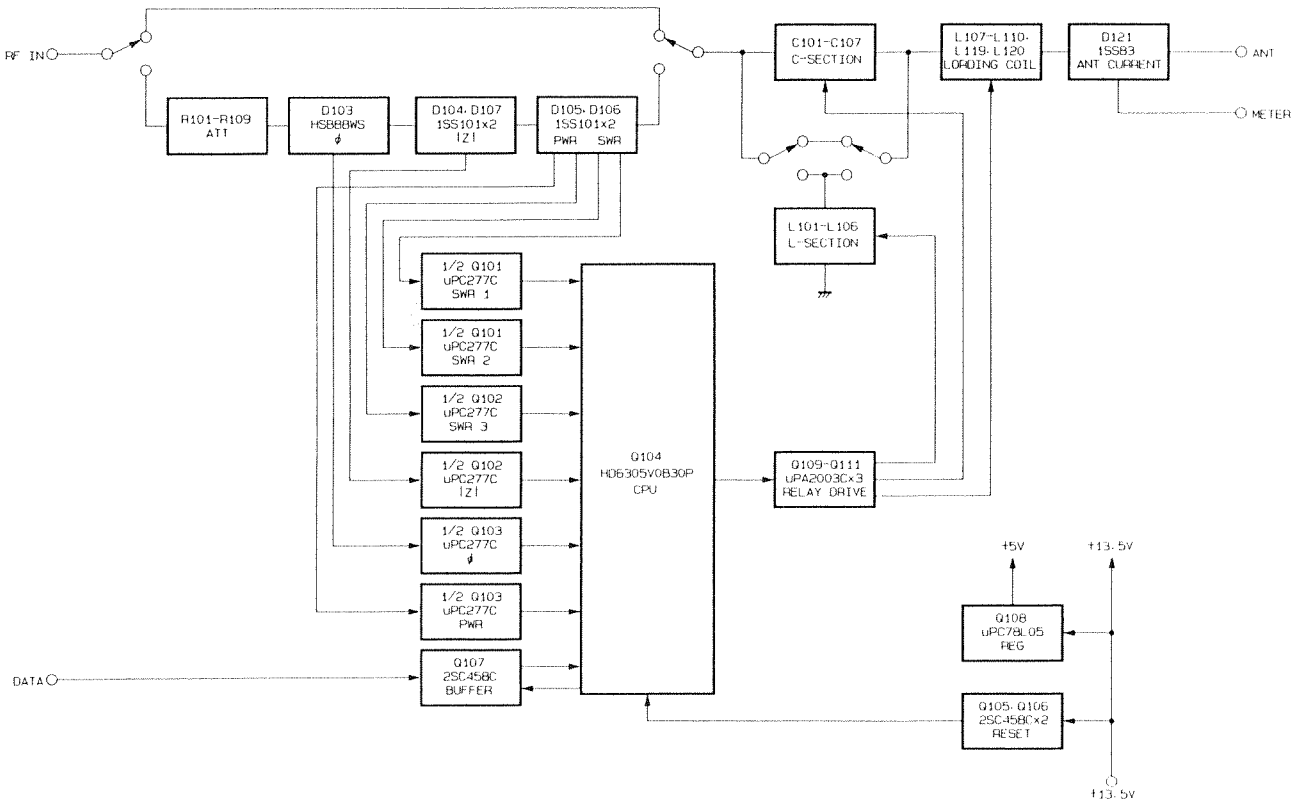

CONTROL UNIT CIRCUIT DIAGRAM

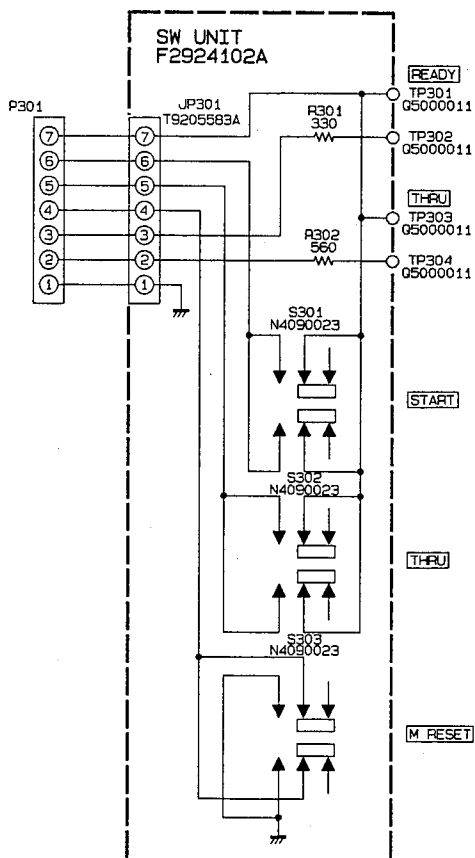
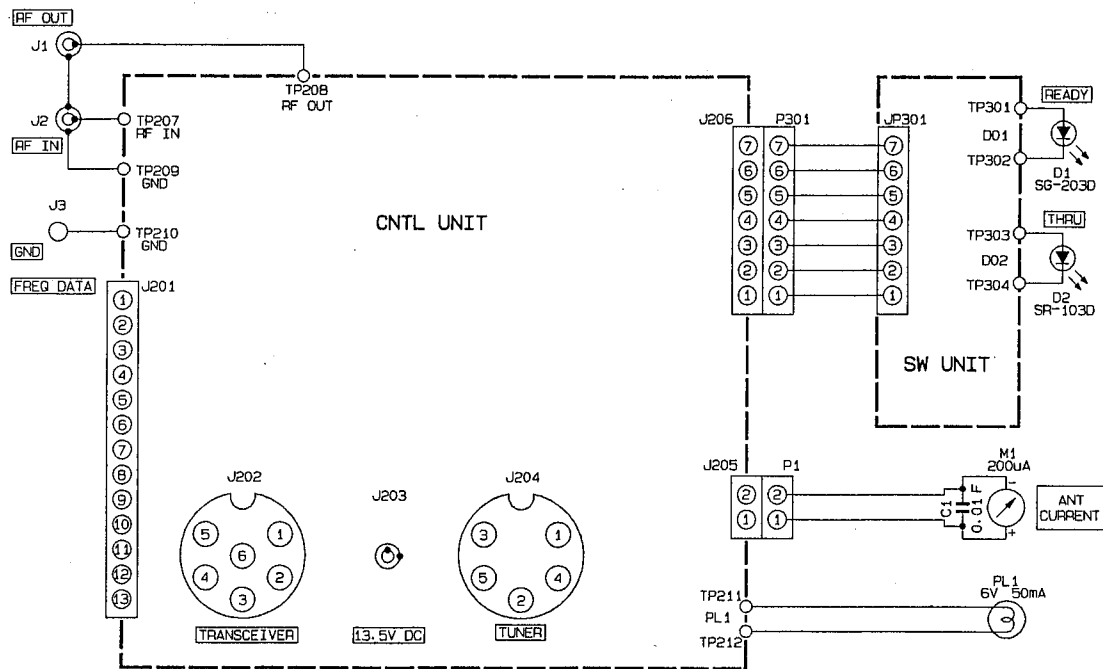

CONTROL UNIT CIRCUIT DIAGRAM

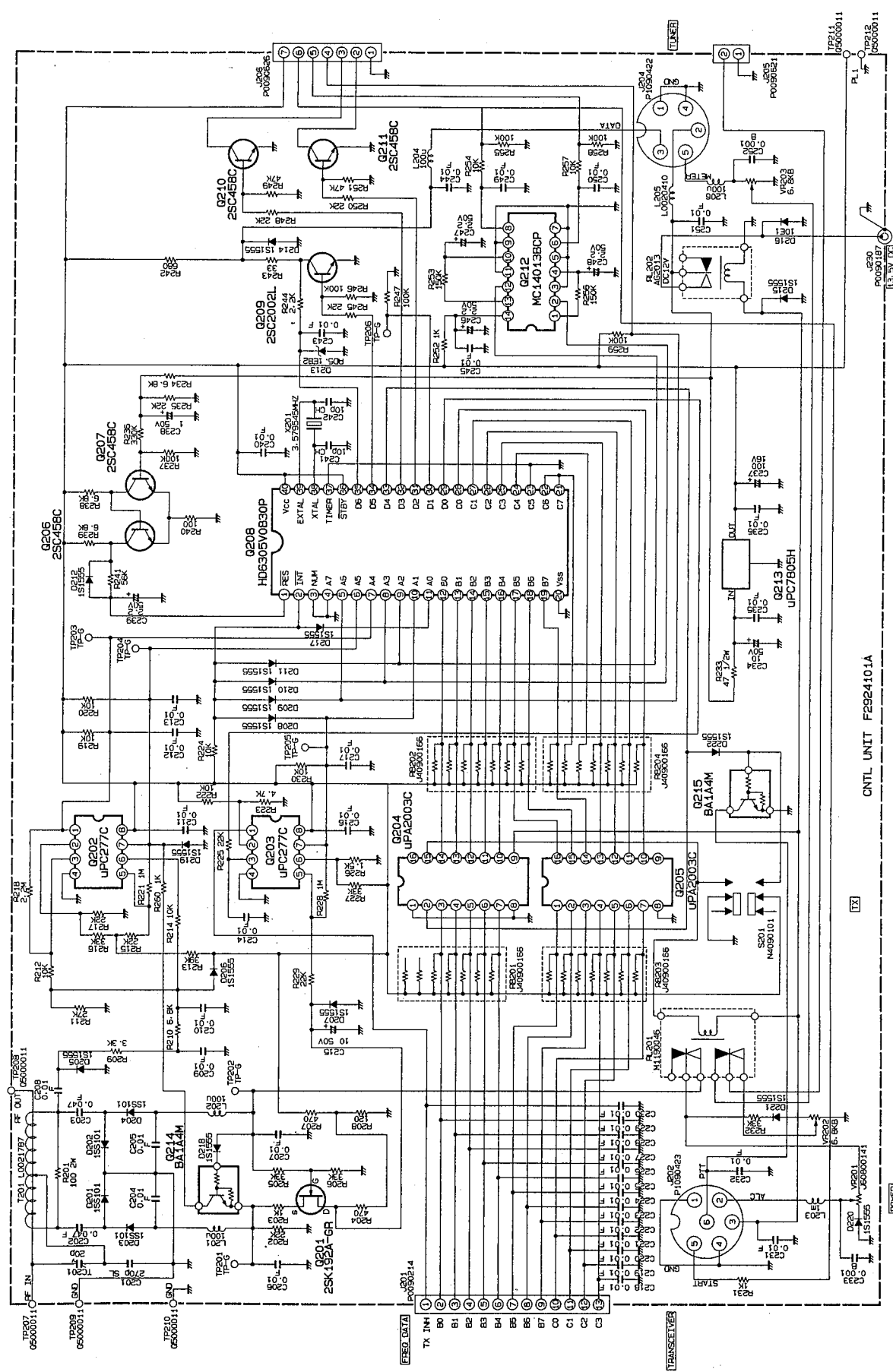

NOTE:
RESISTOR VALUES ARE IN Ω , K, M;
CAPACITOR VALUES ARE IN P, F, 50V;
UNLESS OTHERWISE NOTED.

CNTL UNIT F2924101A

TUNER UNIT CIRCUIT DIAGRAM

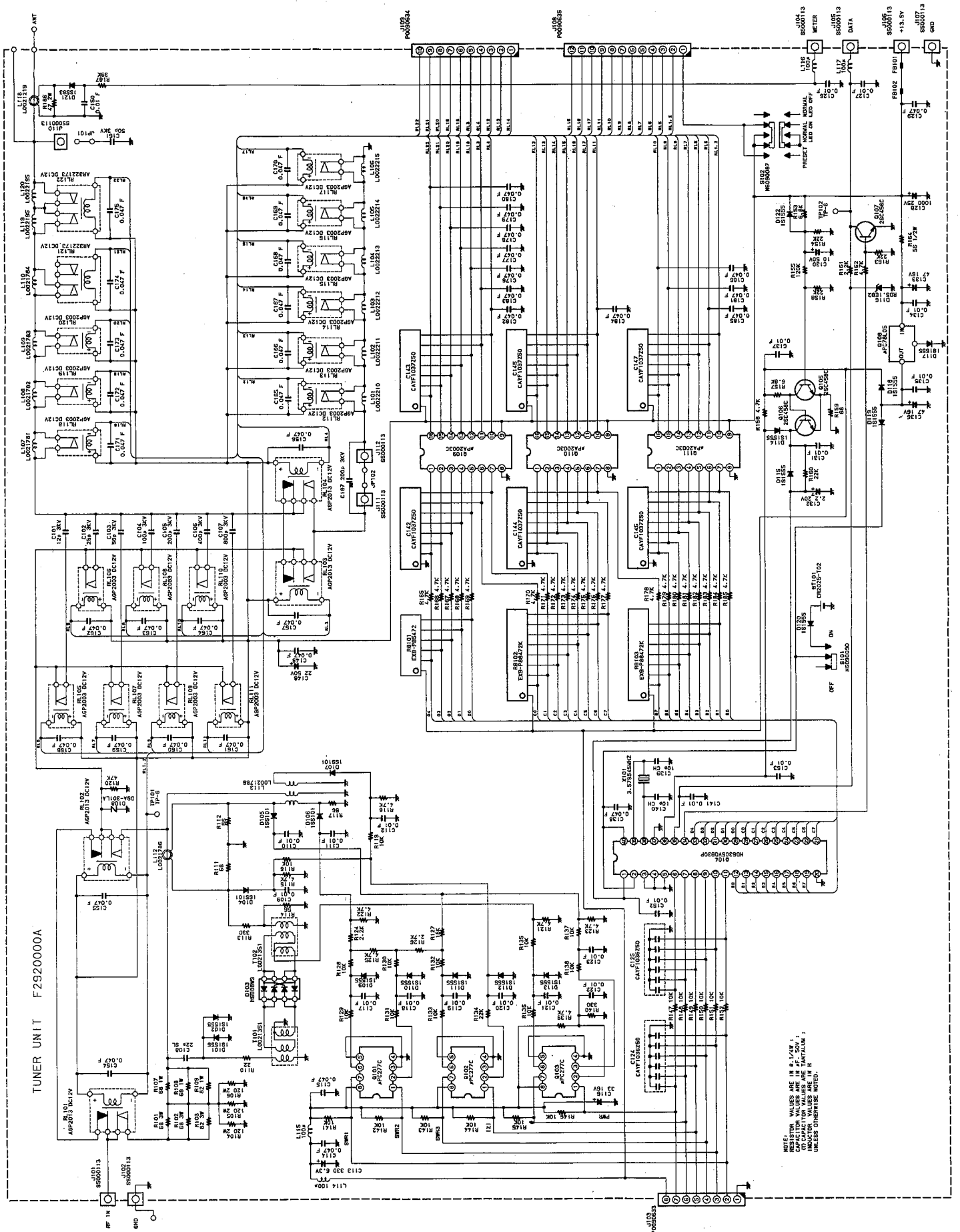

NOTE:
RESISTOR VALUES ARE IN Ω , $\text{k}\Omega$, $\text{M}\Omega$,
CAPACITOR VALUES ARE IN pF , μF , mF ,
INDUCTOR VALUES ARE IN mH ,
UNLESS OTHERWISE NOTED.

TUNER UNIT F2920000A

YAESU
Performance without compromise.SM