

**INSTRUCTION  
MANUAL  
FL-2000B**

**YAESU MUSEN CO., LTD.  
TOKYO JAPAN**

Downloaded by   
  
**Amateur Radio Directory**

\*\*\*\*\*  
FL-2000B LINEAR AMPLIFIER  
\*\*\*\*\*

GENERAL

The YAESU FL-2000B Linear Amplifier is designed to match the "F" series transceivers and transmitters in appearance and drive requirements to run high power Snout covering the ham bands 80 through 10 meters.

The FL-2000B uses a pair of 572B/T160 transmitting triodes in a class B grounded grid circuit configuration. The tubes are forced— air cooled by two very quiet high speed internal fans.

Automatic Level Control circuit controls the exciter gain to allow the highest average power without distortion caused by peak clipping. Changeover circuit biases the tubes to cut-off, eliminating unwanted heat and diode noise generation when receiving.

An internal changeover relay feeds the antenna to the exciter for barefoot operation when the FL-2000B is turned off or is on standby condition. A built-in SWR bridge measures SWR on by barefoot and linear operations.

The built-in solid state power supply requires no warm-up period and provides excellent voltage regulation.

**CAUTION**

DO NOT TURN ON THE FL-2000B WITH THE TOPSHIELD COVER REMOVED. THE HIGH VOLTAGE SAFETY LOCK SHORTS OUT THE HIGH VOLTAGE AND WILL DAMAGE THE POWER SUPPLY CIRCUIT.

## SPECIFICATIONS

Circuit	: Grounded Grid Class B
Frequency Coverage	: Ham bands 80 through 10 meters
Plate Input	: 1200 Watts PEP, 1000 Watts CW and 600 Watts AM
Plate voltage	: 2400 Volts DC
Drive Requirement	: 100 Watts PEP
Input Impedance	: 50 ohms, unbalanced
Output Impedance	: 50 - 75 ohms, unbalanced
Third Order Distortion	: 30 db or better at 1000 Watts PEP
Tube Complement	: 2 x 572B/T160
Cooling	: Forced-air cooling
Power Requirements	: AC 100, 110 Volts 50/60Hz 17 Amps AC 200, 220, 230 Volts 50/60Hz 9 Amps
Dimensions	: 14 <sup>1/2</sup> " Wide, 6 <sup>1/4</sup> " High, 11 <sup>1/2</sup> " Deep
Weight	: 44 lbs

## FRONT PANEL CONTROLS

POWER - OFF	: Rocker switch turns power on
OPER - TUNE.	: Rocker switch applies Bias when standby and relay is disengaged.
SWR - IP	: Rocker switch selects either SWR or plate current meter reading.
F - R	: Rocker switch selects either forward or reflected SWR bridge reading.
SENS	: Potentiometer adjusts meter sensitivity for SWR measurement.
PLATE	: Plate capacitor in tank circuit.

## INSTALLATION



The FL-2000B has been designed incorporating two safety locks to prevent dangerous high voltage shock. However, extreme care is recommended when servicing inside the cabinet.

## Unpacking

Carefully remove FL-2000B and tubes from their packing cartons and examine them for any visible shipping damage, check the control knobs and switches for complete freedom of action. Should any damage be apparent, notify the delivering carrier immediately stating the nature of the damage in detail.

## Tube Installation.

Tubes can be installed after removing the top cover (see SERVICING). First, check to see if the tube holders at the tube sockets are loose enough to install tubes. If not, loosen them. Notice the mark pin of the tube base comes to the right of the socket for correct insertion into the socket.

Push the tubes straight in to insert them and fasten the tube holders. Insert the plate caps on the top of the tubes. Check to make sure that the plastic choke coil has enough clearance from the surrounding parts to avoid electrical short.

After replacing the top shield of the tube compartment and the top cover, the amplifier can be connected for operation.

In general, care should be taken to insure that enough space is allowed around the amplifier cabinet to permit adequate air circulation within the linear amplifier. Do not cover the top of the FL-2000B with books, papers or other equipment. Do not insert anything under the bottom of the FL-2000B or overheating may result.

## POWER REQUIREMENT

The FL-2000B has a built-in power supply which can be operated from either 100, 117 or 220 volts AC 50-60 cps. The FL-2000B is shipped from the factory connected to operate on 220 volts AC.

It is recommended that the FL-2000B is operated from its own 220 volt 10 amp or greater circuit. If 117 or 100 volts is all that is available, it should be fused for 20 Amps, circuit conductors should be larger than #10 and no other equipment should be operated from this circuit. Do NOT, under any circumstances, operate the FL-2000B from a 115 volt lighting circuit, as the circuit conductors are not large enough to carry this load.

The following diagram shows the wiring connections for 1 10, 1 15 and 220 volt operation. Connections must be made as shown or serious damage may result.

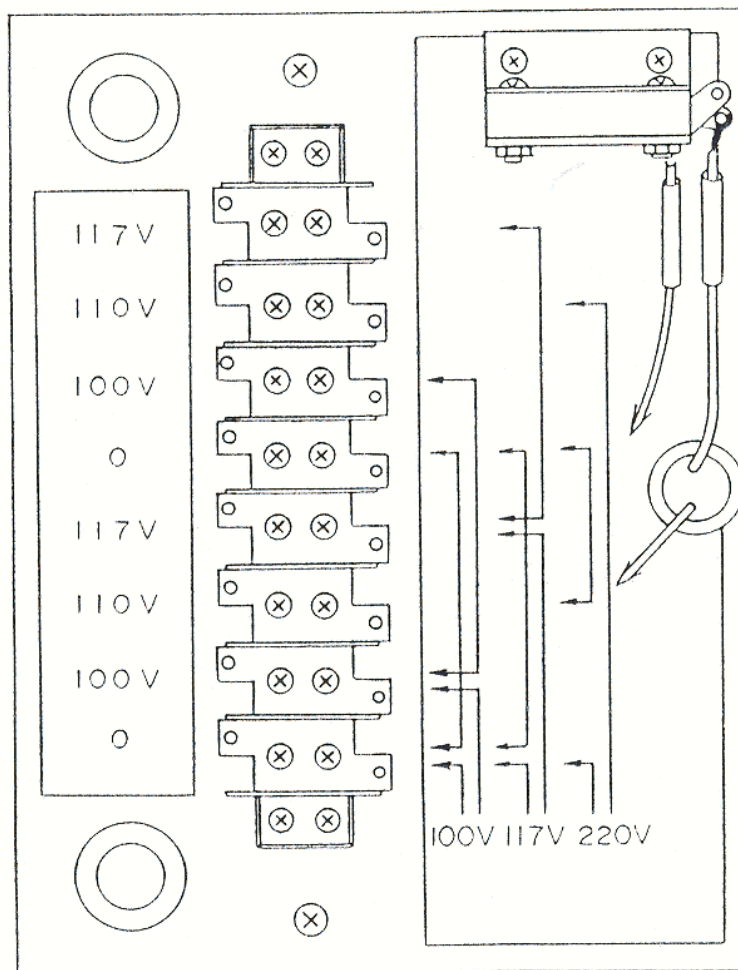

## ANTENNA REQUIREMENT

The FL-2000B has been designed for use with an antenna resonant at the operating frequency and having approximate impedance within the limit of 40 to 80 ohms. The nominal output impedance of the FL-2000B is 50 ohms. When the impedance of the antenna used is far from this value, it is recommended that an antenna matching network be used which will allow the FL-2000B to work into its nominal 50 ohm load for maximum power transfer into the antenna.

## GROUND REQUIREMENT

The FL-2000B should be connected to a good earth ground through as short and as large a gauge wire as possible for best performance and maximum safety. A connecting post marked "GND" is provided on the rear apron of the chassis.

## CAUTION

NEVER OPERATE THE FL-2000B WITHOUT FIRST CONNECTING IT TO AN EARTH GROUND, AND AN ANTENNA OR 50 OHM DUMMY LOAD, OR SERIOUS DAMAGE MAY RESULT.

## EXCITER REQUIREMENT

To operate the FL-2000B at its maximum power input, it will be required that the exciter deliver 100 Watts PEP SSB output. Our FT-400/500, FT-560, FT-200 and FT-101 transceivers and FL-400 transmitter all have sufficient power to drive the FL-2000B at its maximum input. The exciter should be placed as close to the amplifier as practical to avoid long coax and ground connections.

## ALC

On the rear of the FL-2000B, a terminal is provided for connection to the exciter of the ALC voltage which controls the gain of the exciter to prevent distortion caused by peak clipping.

## Relay Control

RY and E terminal on the rear of the FL-2000B are provided for connection to the exciter relay circuit which is normally open, and which closes on transmit and thus keys the FL-2000B at the same time. E terminal should be connected to ground for exciters whose relay contact connects to ground on transmit. The terminals are jumpered with a wire for testing purposes when the unit is shipped from the factory.

## OPERATION

### CAUTION

BE SURE THAT THE FL-2000B IS CONNECTED TO A 50 OHM ANTENNA SYSTEM OR A 50 OHM DUMMY LOAD AND THAT THE PROPER POWER CONNECTION HAS BEEN MADE FOR THE LINE VOLTAGE THAT IS TO BE USED. (SEE PAGE 4)

For all modes of operation, the FL-2000B is tuned up with a single R. F. frequency driving it. The exciter may be tuned up on CW into the antenna connected to the FL-2000B with operation switch at STBY position, or by leaving the FL-2000B power off. After the exciter has been tuned up, turn the exciter to standby and turn the operation switch to "OPER" position.

### Presetting of the Controls

POWER switch	: OFF
OPER switch	: STBY
SWR/IP switch	: IP
BAND switch	: Desired band
PLATE Control	: To the number given in the following chart
LOAD Control	: Fully counter-clockwise on number zero

BAND	PLATE	LOADING
80	4	2
40	6-7	3
20	7-8	4
15	8-9	5
10	9	6

Turn the power switch of FL-2000B on and wait for a few seconds for tube warm up. Turn OPER switch onto "OPER" position.

Turn on the exciter and increase the exciter output while not exceeding 0.2 Amps plate current and tune the-plate control for dip in the plate current. Alternately adjust the plate and heading controls while increasing the exciter-power in small increments until maximum R. F. output occurs at 0.5 Amps plate current. Do not exceed 10 seconds at maximum input to protect the tubes.

To measure relative power output, set the meter switch to "SWR" and "F" (forward) position. If the relative output meter goes off scale during tune up, reduce the meter sensitivity control in a downward direction. Approximate settings of the loading control at maximum input are given in the chart on page for 50 ohm load.

Now you are ready for CW and SSB operation.

For SSB operation, the exciter should be adjusted to run the FL-2000B plate current between 0.2 and 0.3 Amps under normal voice operating conditions, because the meter cannot follow speech speed.

For AM operation, tune up the FL-2000B as described previously. Then the exciter should be adjusted to run the FL-2000B at 0.2 Amps plate current with unmodulated carrier.

To measure the SWR of the antenna system, set the meter switch to SWR and apply R. F. power to the antenna. Adjust the meter sensitivity control to read



full scale at SWR switch "F" position. Turn SWR switch to "R" position, then SWR may be read directly from upper scale of the meter.

## THEORY OF OPERATION

The FL-2000B is designed to use two 572B/T160 zero bias triodes in a class B grounded grid configuration.

The RF driving power delivered to the input is applied to the tube filaments through a changeover relay and a pi-network on each band which is selected by the input switch S2a. The input switch is ganged to the band switch S1.

The RF voltage appearing on the grid of the tube is coupled through C203 to ALC rectifier diodes D201 and D202. The plate potential of D201 is determined by R1, R2, R3, so that adequate automatic level control voltage is available to control the exciter. The bias is set by R4 for 0.09 Amps idle current. In standby, the cold end of S4 is opened so that bias voltage cuts off the tubes. The plate circuit is coupled to the 50 ohm output load by an adjustable pi-network through the SWR bridge circuit.

## SERVICING

### WARNING

EXTREME CAUTION SHOULD BE TAKEN WHENEVER MAKING ANY ADJUSTMENTS INSIDE THE CABINET. BEFORE OPENING THE CABINET COVER, UNPLUG THE POWER PLUG FROM THE AC LINE.

### Removing Top and Bottom Covers

After disconnecting the power cord from the AC line, the top cover can be easily and safely removed by pulling up the two lock fasteners.

The bottom cover can be removed by taking out the four screws on it.

### Removing Shield Cover

After removing the top cover, the shield cover of the PA compartment can be removed by taking out two screws on the shield cover. The safety lock shorts out the charge condensed in the capacitor.

### Removing the Cabinet

After removing six screws on the front end and two in the bottom of the cabinet, the cabinet can be slid out backwards from the chassis and panel assembly.

### Tube Replacement

If it becomes necessary to replace the tubes in the FL-2000B, the same manufacturer brand should be used.

### Trouble Shooting

During long periods of operation, it is quite possible that some problem will arise which cannot be cured by tube substitution. If this occurs, it is recommended that you either return it to your dealer or write us in detail.

### Input Coil Alignment

The input coils are adjusted at the factory for the center of each band and are broad enough to cover the entire band. However, if the tubes are replaced with a brand other than originally supplied, the input coils may have to be realigned. The alignment is done with a 50 ohm SWR meter inserted between the exciter output and the FL-2000B's RF input coax jack. First disconnect the FL-2000B from the power line, remove the top and bottom covers and disconnect the wiring from the high voltage transformer secondary terminals.

Recover the top cover. The amplifier should be connected to the exciter as for normal operation with the exception of the SWR meter in the input line. Preset the controls as follows:

Band Switch : On desired band to be tuned  
Loading : Fully counter-clockwise  
Plate Control : In the position described on page 7.

With the exciter tuned up on CW in the middle of the band to be tuned, turn on the FL-2000B. The amplifier now works without plate voltage. Extreme care should be taken, because there is high voltage AC on the secondary terminals of the high voltage transformer.

Increase the output from the exciter until the amplifier plate meter read 0.1 Amps. Tune the 'plate control for a dip in plate current and tune the slug on the correct input coil for a minimum reflected power reading on the SWR meter that is connected to the input line.

After re-alignment, disconnect the power cord from the AC line and reconnect the disconnect wiring to the secondary terminals of the transformer.

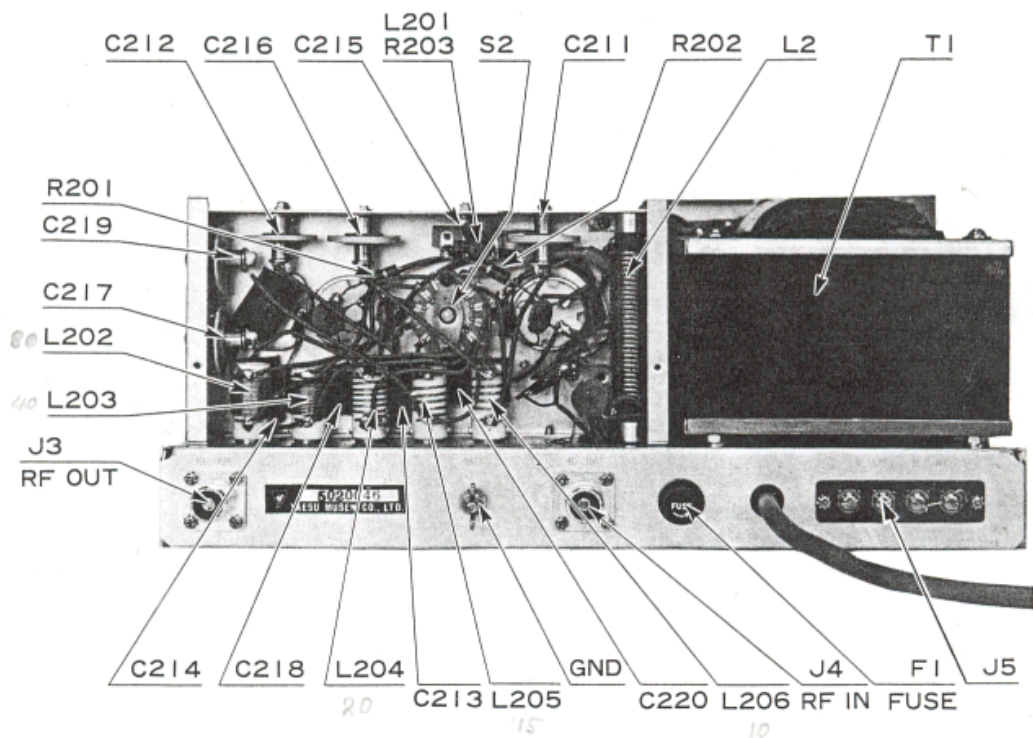
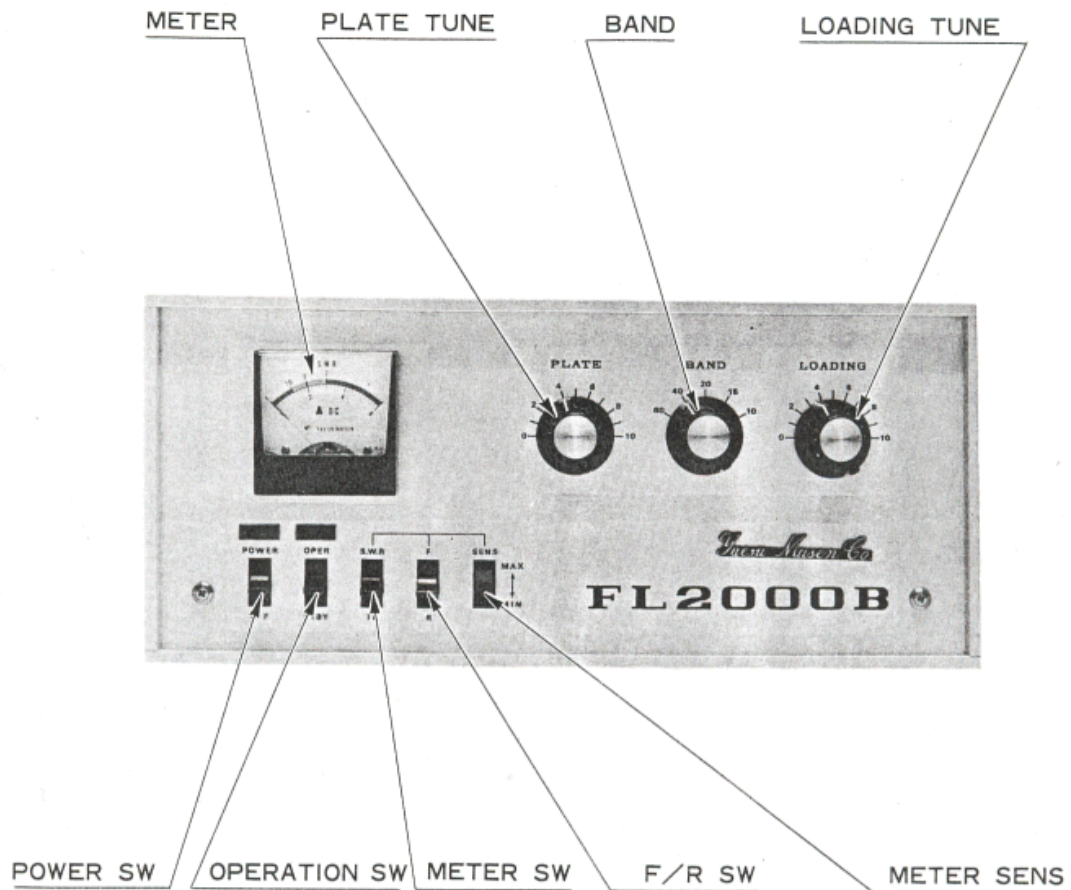

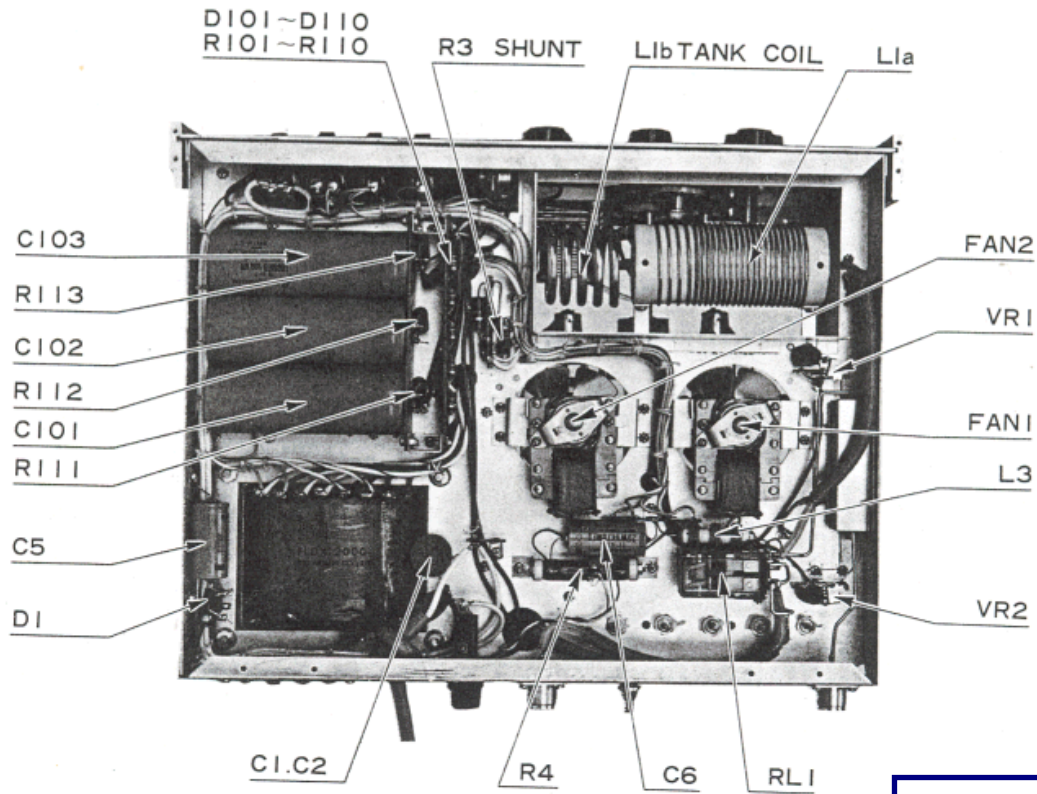
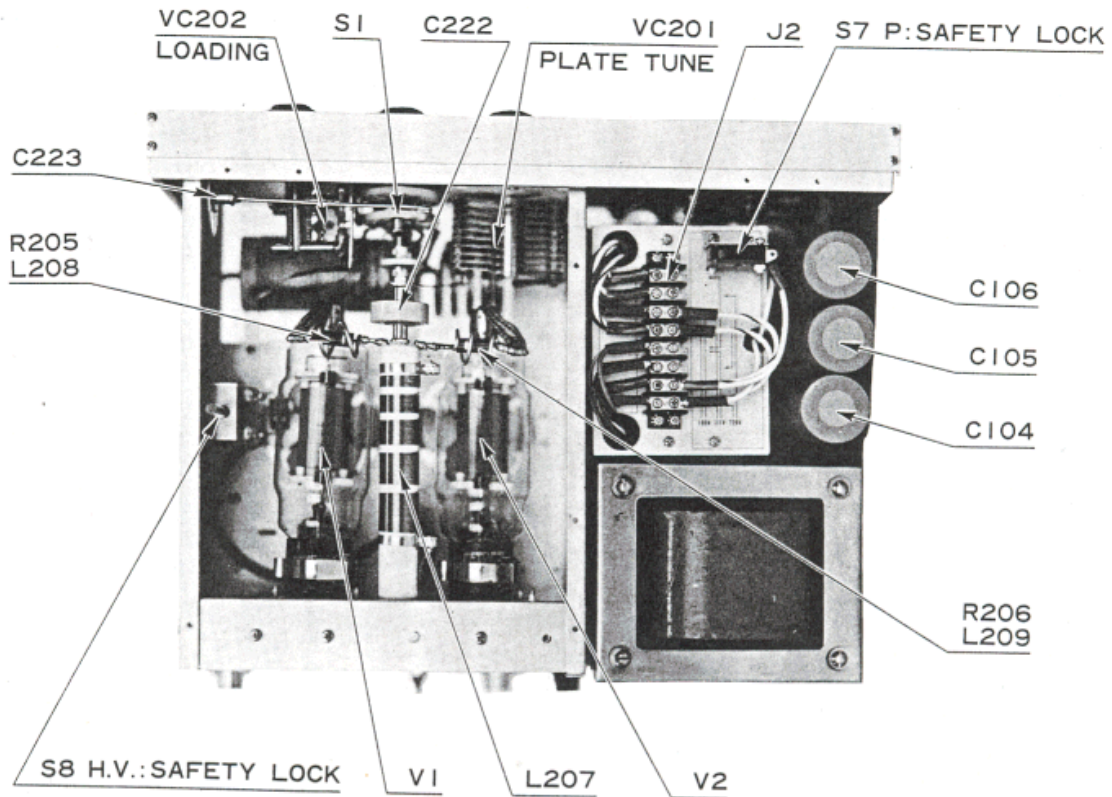

BIAS 0-9  
- 12 -

Downloaded by   
  
Amateur Radio Directory

INTERCONNECTION SCHEMATIC

FTdx-400/500/560 Transceiver

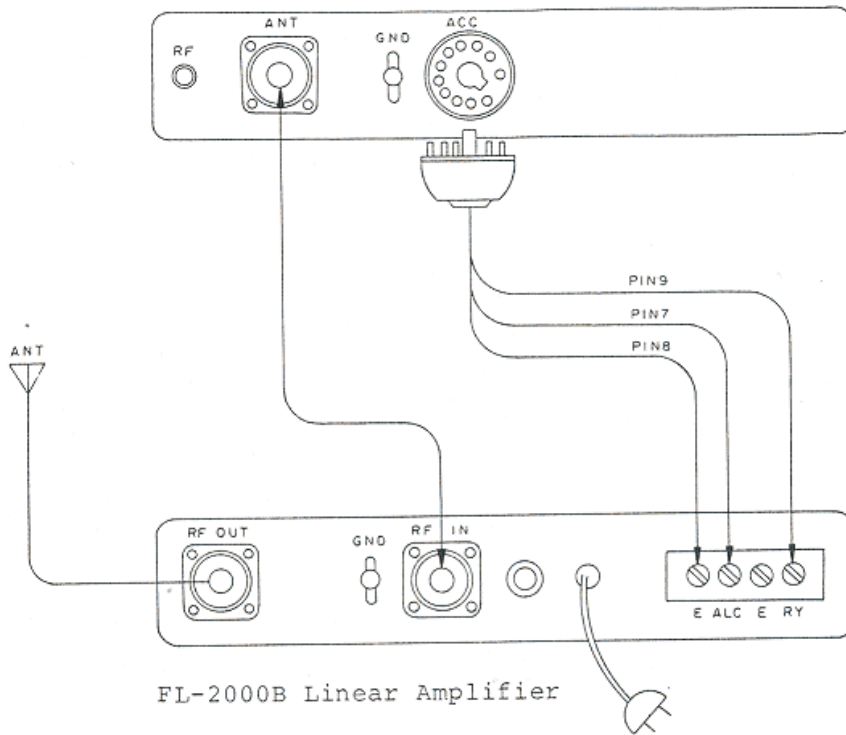

FL-2000B Linear Amplifier

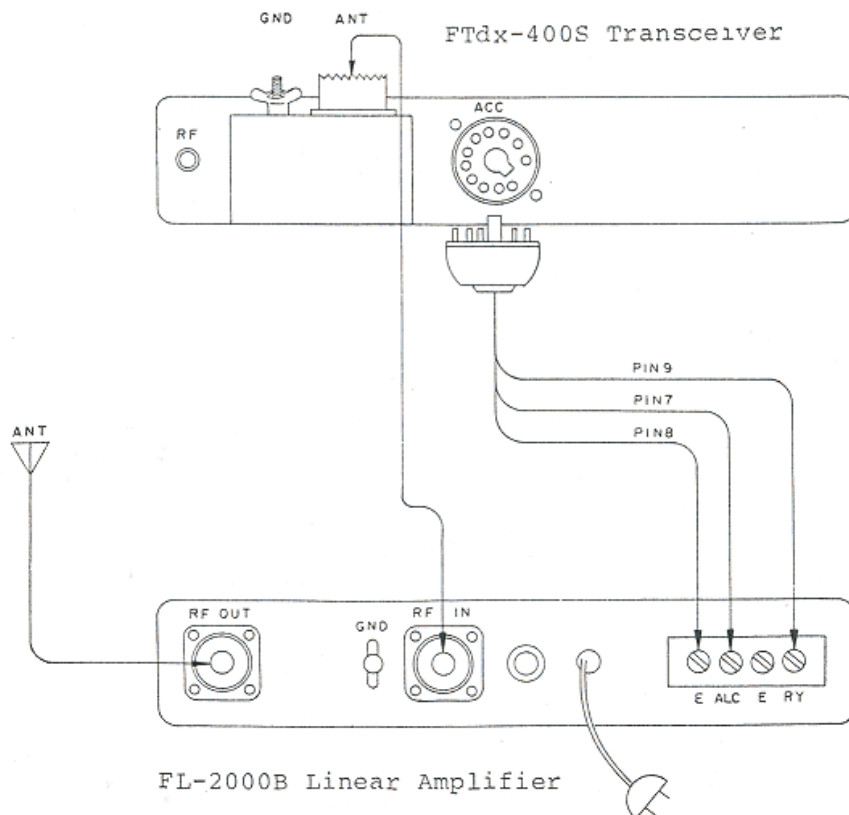

FL-2000B Linear Amplifier



### FL2000B BLOCK DIAGRAM

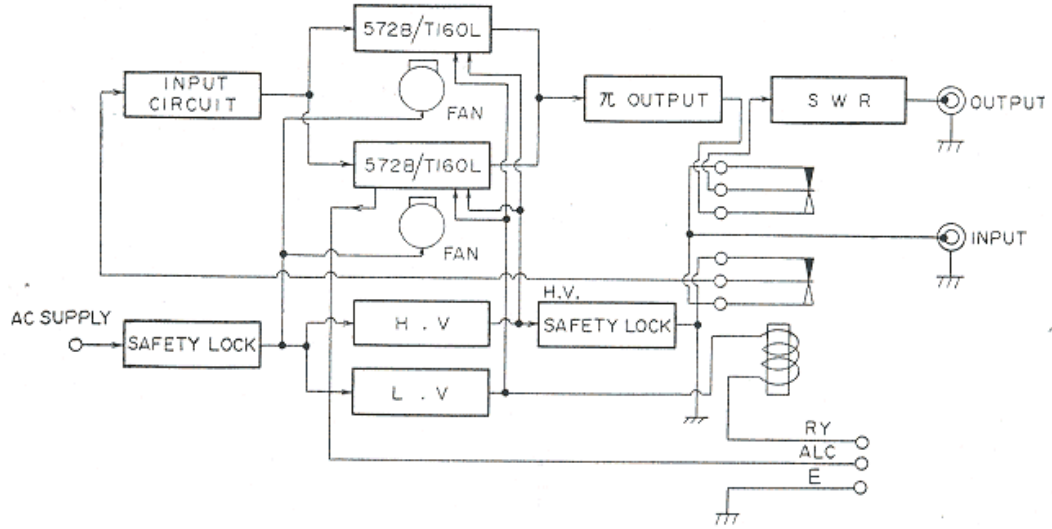

### INTERCONNECTION SCHEMATIC

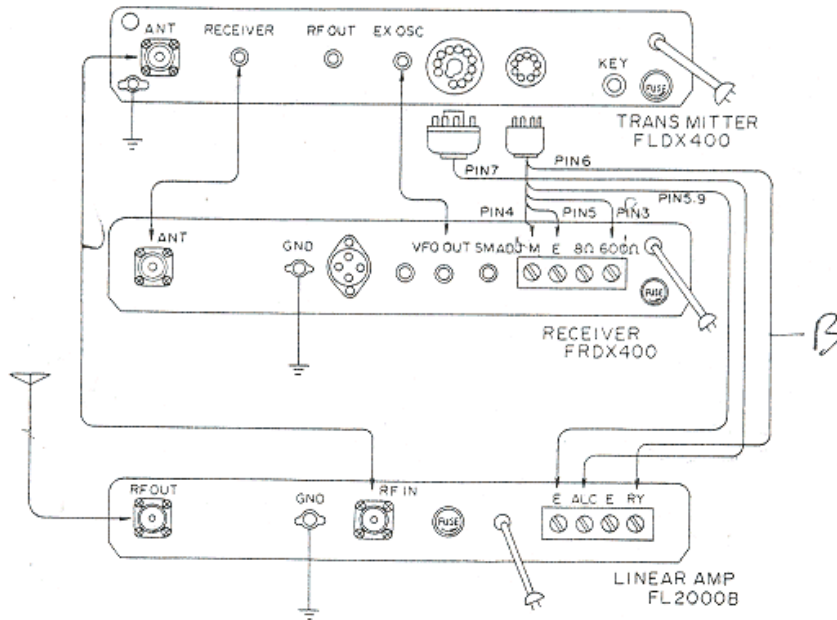

PIN  
394  
ER

B

Downloaded by   
  
Amateur Radio Directory

# FL-2000B PARTS LIST

C-CAPACITOR		S-SWITCH	
1, 2	CERAMIC DISC 1.4KV DC 0.01 $\mu$	1	BAND SW
3, 4, 7, 8, 9	CERAMIC DISC +100% 500WV 0.01 $\mu$ -0	2	" 2-4-5
205~208, 210, 225		3	(POWER) WD 2301
5, 6	ELECTROLYTIC 25WV 500 $\mu$	4	(OPER-STBY) WD 2301
209	ELECTROLYTIC 25WV 2.2 $\mu$	5	(METER SW) WD 2101
101~106	ELECTROLYTIC 500WV 100 $\mu$	6	(SWR F-R) WD 2101
201, 202	FM 500WV 200P $\pm$ 10%	7	P-SAFETY LOCK AM 5116
203	" 5P "	8	P SAFETY LOCK
204	" 50P "		F-FUSE
211, 215, 224	CERAMIC TV3K RDA 30-100P	1	AC 100V~117V 15A
212, 217	" " 250P		AC 200V~234V 10A
216	" " 200P		FH-FUSE HOLDER
226	" " 300P	1	SN-1001
222, 223	CERAMIC TV3K RDA 40 500P		PL-PILOT LAMP
213	MICA TV6K 350P	1, 2	15V SWAN
214, 219	" 500P		M-METER
220	" 1000P	1	BW 22 1mA
218	" 400P		FAN
	R-RESISTOR	1, 2	2S10A (FAN)
101~110	$\frac{1}{2}$ W 470K $\Omega$ $\pm$ 10%		J-JACK
2	" 2.2K $\Omega$ "	2	H, 8P
204	" 4.7K $\Omega$ "	3, 4	JSO-239 (INCH)
201, 202	1W 33 $\Omega$ $\pm$ 10%	5	4PC
203	" 3.3K $\Omega$ "		P-PLUG
205, 206	2W 22 $\Omega$ $\pm$ 10%	3, 4	M-P-7 (INCH)
11	" 47K $\Omega$ "		VC-VARIABLE CAPACITOR
1 111~115	" 220K $\Omega$ "	201	(PLATE VC) 120P (MAX) AIR
4	VARIABLE (BIAS SET) 10W 30 $\Omega$	202	(LOADING VC) 430P $\times$ 2 AIR
3	M-1 SHUNT		VR-VARIABLE RESISTOR
	V-VACUUM TUBE	1, 2	B500 $\Omega$
1, 2	572B/T 160L	3	B100K $\Omega$
	VS-VACUUM TUBE SOCKET		L-INDUCTOR
1, 2	UX 4P	1a	TANK COIL
	D-DIODE	1b	10M TANK
2, 3, 201	1S1007	201	GRID RFC
1, 202	SILICON 1S1943or SH-1	202	80M INPUT COIL
101~110	" 10D10	203	40M "
	T-TRANSFORMER	204	20M "
1	HIGH VOLTAGE-T	205	15M "
2	HEATER -T	206	10M "
		207	PLATE RFC
		2	HEATER CHOKE
		3	RFC
		208, 209	PARASTIC COIL
			RL-RELAY
		1	AM 5221GK DC 12V



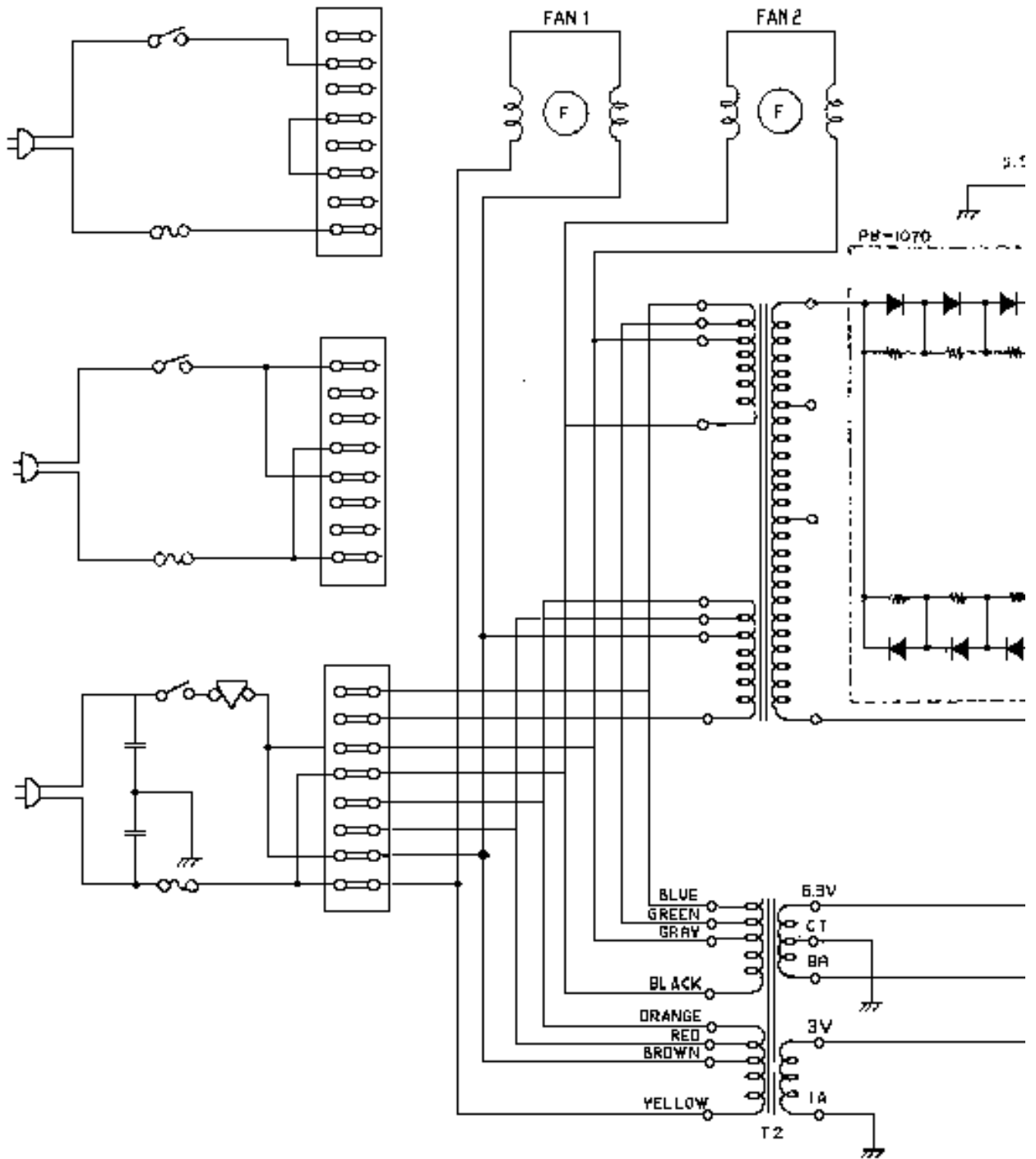

VI 572B/ T160L

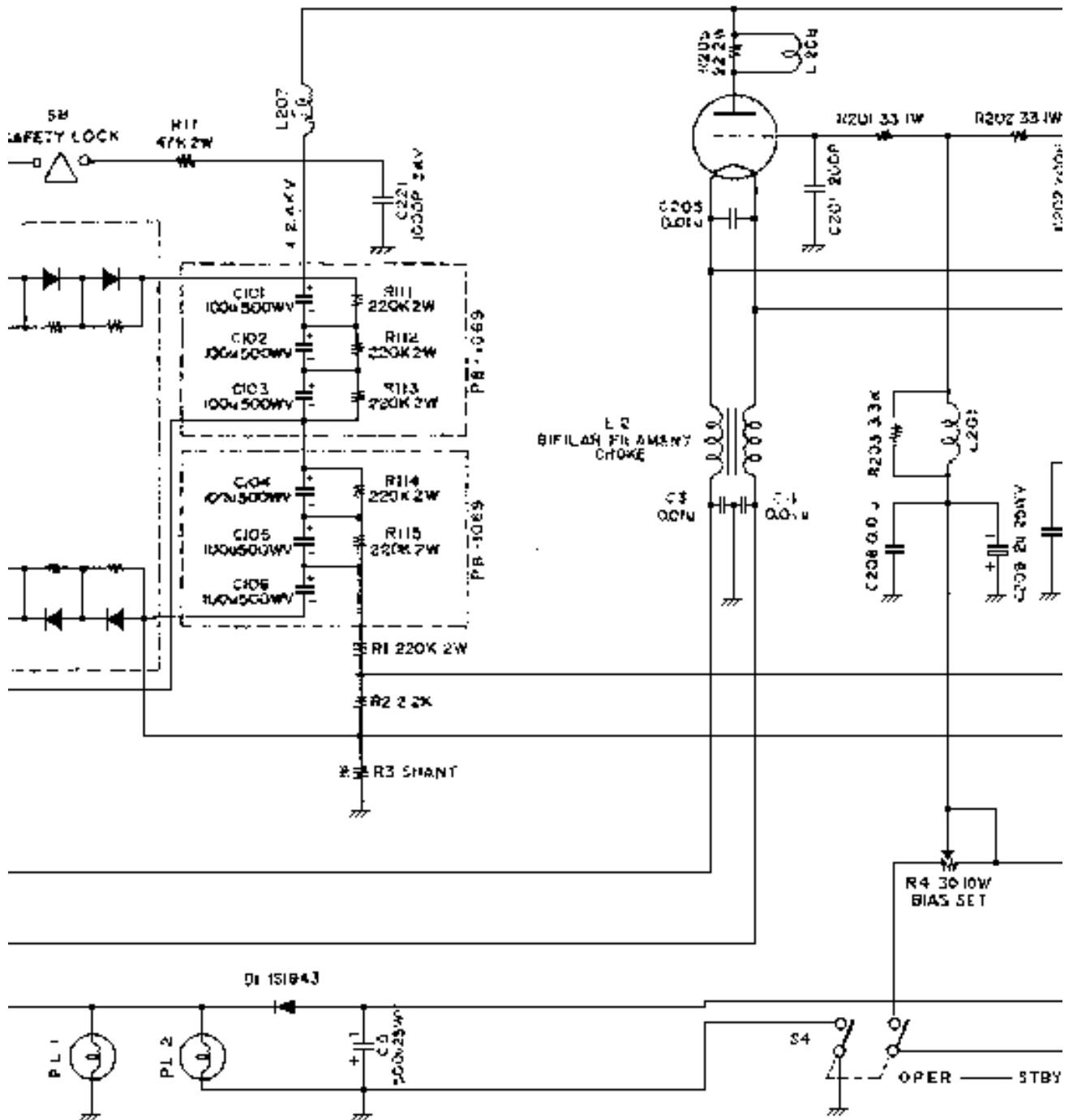

V2 5/2B/T160L

