

 **YAESU**

GS-232B

*Computer Control Interface
for Antenna Rotators*

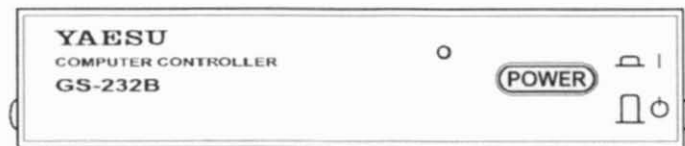

VERTEX STANDARD CO., LTD.

4-8-8 Nakameguro, Meguro-Ku, Tokyo 153-8644, Japan

VERTEX STANDARD

US Headquarters

10900 Walker Street, Cypress, CA 90630, U.S.A.

YAESU EUROPE B.V.

P.O. Box 75525, 1118 ZN Schiphol, The Netherlands

YAESU UK LTD.

Unit 12, Sun Valley Business Park, Winnall Close
Winchester, Hampshire, SO23 0LB, U.K.

VERTEX STANDARD HK LTD.

Unit 5, 20/F., Seaview Centre, 139-141 Hoi Bun Road,
Kwun Tong, Kowloon, Hong Kong

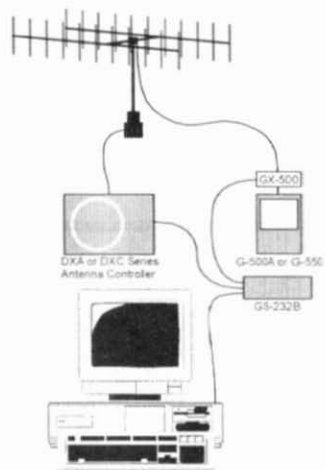
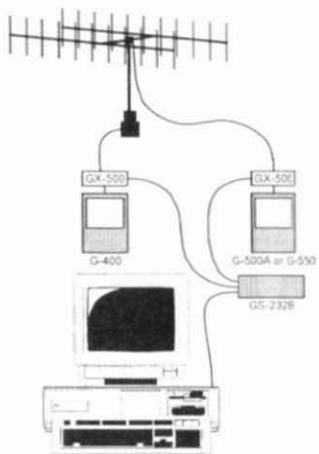
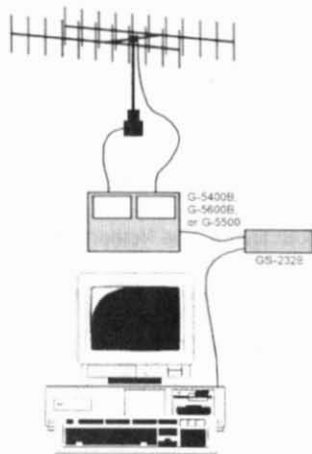
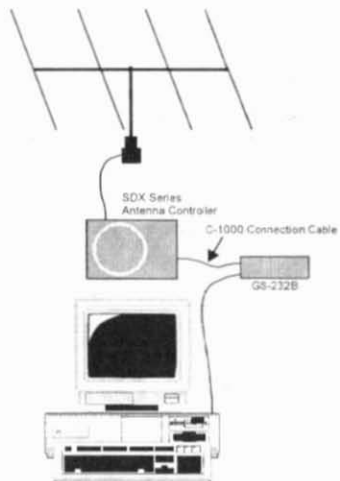
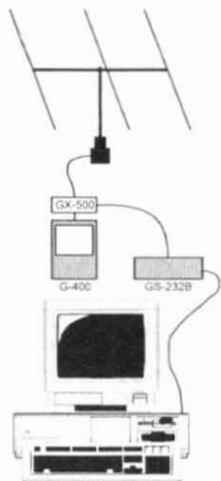
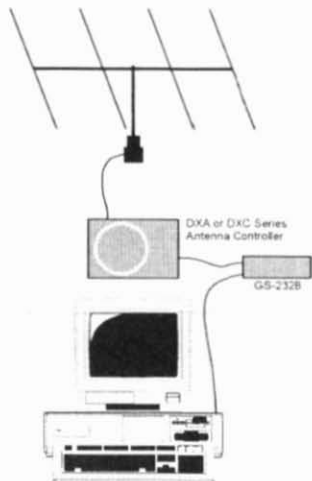

GS-232B Computer Control Interface

for Yaesu Antenna Rotators

The **GS-232B** provide digital control of most models of Yaesu antenna rotators* from the serial port of an external personal computer.

The **GS-232B** contains its own microprocessor with a 10-bit analog-to-digital (A-D) converter and EEPROM. The async serial line can be configured for serial data rates from 1200 to 9600 baud. The **GS-232B** has a DB-9 "male" connector for connection to the (RS-232C) COM port of your computer. Purchase or construct a "straight" type serial cable, ensuring it has the correct gender and number of pins for connection to your system.

Firmware on the **GS-232B** supports either direct keyboard control, or commands from programs written specifically to support it (software is not supplied by Yaesu). In addition to reading and setting antenna angle and rotation speed, the firmware includes clocked positioning routines to auto-

matically step the antenna through up to 3800 angles at programmable intervals, such as for tracking band openings or satellites (with an elevation rotator).

Please read this manual carefully to install the **GS-232B**. If also installing a **G-400**, **G-500A** or **G-550** with the **GX-500** Automatic Control Adapter, follow the procedures in the **GX-500** manual before installing the **GS-232B**.

- ※ **G-800DXA/G-1000DXA/G-2800DXA** Azimuth Rotator,
G-800DXC/G-1000DXC/G-2800DXC Azimuth Rotator,
G-400 Azimuth Rotator,
G-500A/G-550 Elevation Rotator,
G-5400B/G-5600B/G-5500 Az-El Rotator, and
above Azimuth and Elevation rotator combination.
- G-400** Azimuth Rotator and **G-500A/G-550** Elevation Rotator requires one **GX-500** Automatic Control Adapter each.

GENERAL

- Power Requirements:** DC 12 V, 70 mA
Case Size: 4.3" (W) x 0.8" (H) x 5.4" (D)
(110 x 21 x 138 mm)
Weight (approx.): 13.4 oz. (380 g)

Semiconductors

- Microprocessor:** PIC18C452
(includes 10 bits A/D converter)
EEPROM: 24LC256
Serial Comms: RS-232C voltage levels,
1200 to 9600 baud, 8 data bits,
1 stop bit, no parity
Overflow Cont.: Hardware Control (CTS port)

CONNECTOR PINOUTS

Serial I/O:

- 9-pin DB-9 connector (**RS-232C** connector)
Pin 2 - Tx Data
Pin 3 - Rx Data
Pin 5 - Signal Ground
Pin 7 - RTS
Pin 8 - CTS

Rotator Control:

- 5-pin connector (**EL** connector)
Pin 1 - UP switch (open collector)
Pin 2 - DOWN switch (open collector)
Pin 3 - analog output (0.5 - 4.5 V, four steps)
Pin 4 - analog input (0-5V elevation)
Pin 5 - analog ground
5-pin connector (**AZ** connector)
Pin 1 - RIGHT switch (open collector)
Pin 2 - LEFT switch (open collector)
Pin 3 - analog output (0.5 - 4.5 V, four steps)
Pin 4 - analog input (0-5V azimuth)
Pin 5 - analog ground

SUPPLIED ACCESSORIES

- Control cable for the Azimuth Rotator^{×1} 1 pc
(“5-pin” ↔ “Min-DIN” cable)
- Control cable for the Az/El Rotator^{×2} 1 pc
(“Dual 5-pin” ↔ “DIN” cable)
- DC cable w/coaxial plug 1 pc
- Hook & loop fasteners (for mounting) 1 pc

×1: **G-800DXA, G-1000DXA, G-2800DXA,**
G-800DXC, G-1000DXC, and G-2800DXC

×2: **G-5400B, G-5600B, and G-5500**

AVAILABLE OPTIONS

- GX-500** Control Adapter
(Check with your dealer)
 - C-1000** Connection Cable
(for **SDX** series Azimuth Rotator)
 - NC-72B/C/F/U**^{×3} AC Adapter
- ×3: “**B**” *suffix* is for use with 117 VAC,
“**C**” *suffix* is for use with 220-240 VAC,
“**F**” *suffix* is for use with 220 VAC, or
“**U**” *suffix* is for use with 230 VAC

During installation, a personal computer with a serial port and terminal software is required to calibrate trimmers on the Controller and on the Control Interface. Any simple interactive terminal program can be used - it only has to transmit keystrokes as typed, and display characters received from the **GS-232B**.

POWER & CONTROL CONNECTIONS

DXA or DXC Series Azimuth Rotator

- ❑ Connect the supplied DC cable to a source of 12 VDC. The red lead connects to the Positive (+) DC terminal, and the black lead connects to the Negative (-) DC terminal. The **GS-232B** requires 70 mA. The supplied cable has a 500-mA fast-blow fuse. Use only the same type fuse for replacement.
- ❑ Plug the coaxial power connector into the **DC 12V** jack on the **GS-232B** rear panel.
- ❑ Connect the supplied Control cable ("5-pin" ↔ "Mini-DIN") between the **EXT CONTROL** connector on the rotator's controller and **AZ** connector on the rear panel of the **GS-232B** (Figure 1).

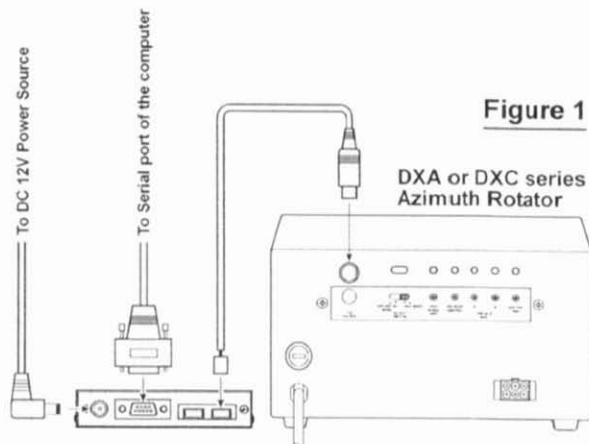
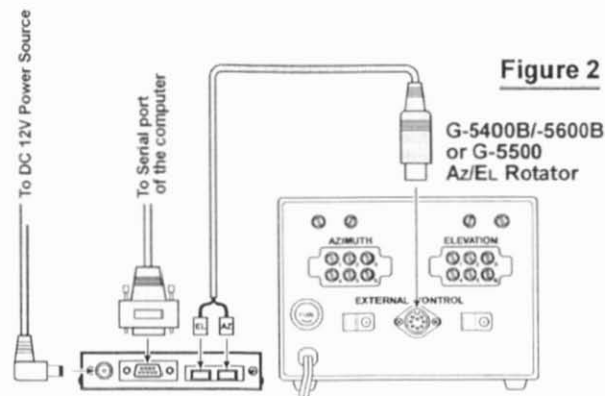

Figure 1

POWER & CONTROL CONNECTIONS

G-5400B/-5600B Az-EL Rotator

- ❑ Connect the supplied DC cable to a source of 12 VDC. The red lead connects to the Positive (+) DC terminal, and the black lead connects to the Negative (-) DC terminal. The **GS-232B** requires 70 mA. The supplied cable has a 500-mA fast-blow fuse. Use only the same type fuse for replacement.
- ❑ Plug the coaxial power connector into the **DC 12V** jack on the **GS-232B** rear panel.
- ❑ Connect the supplied Control cable ("Dual 5-pin" ↔ "DIN") between the rotator's controller and **GS-232B**. Be careful to match the "AZ" and "EL" labels on the cable with the same labels on the rear panel of the **GS-232B** (Figure 2).



G-400/G-500 or G-400/G-550 & pair of GX-500

- ❑ Connect the supplied DC cable to a source of 12 VDC. The red lead connects to the Positive (+) DC terminal, and the black lead connects to the Negative (-) DC terminal. The **GS-232B** requires 70 mA. The supplied cable has a 500-mA fast-blow fuse. Use only the same type fuse for replacement.
- ❑ Plug the coaxial power connector into the **DC 12V** jack on the **GS-232B** rear panel.
- ❑ Connect the 5-pin to 5-pin cable (supplied with the **GX-500**; requires two sets) between the **GX-500(s)** and **GS-232B** (Figure 3).

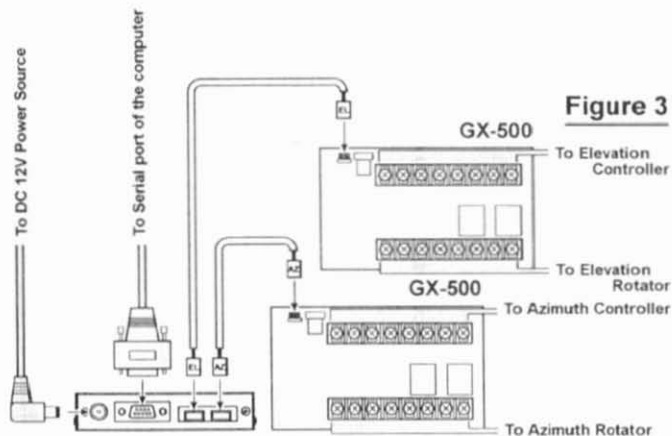

POWER & CONTROL CONNECTIONS

SDX Series Azimuth Rotator

- ❑ Prepare the optional **C-1000** Connection Cable.
- ❑ Remove the Top Cover from the controller.
- ❑ Connect the 8-pin connector of the **C-1000** Connection cable to the exposed 8-pin connector located the rear left corner in the controller.
- ❑ Route the 5-pin connector of the **C-1000** Connection cable through out the rubber grommet on the rear panel of the controller, and connect it to the **AZ** connector on the rear panel of the **GS-232B** (Figure 4).
- ❑ Replace the Top Cover.
- ❑ Connect the supplied DC cable to a source of 12 VDC. The red lead connects to the Positive (+) DC terminal, and the black lead connects to the Negative (-) DC terminal. The **GS-232B** requires 70 mA. The supplied cable has a 500-mA fast-blow fuse. Use only the same type fuse for replacement.
- ❑ Plug the coaxial power connector into the **DC 12V** jack on the **GS-232B** rear panel.

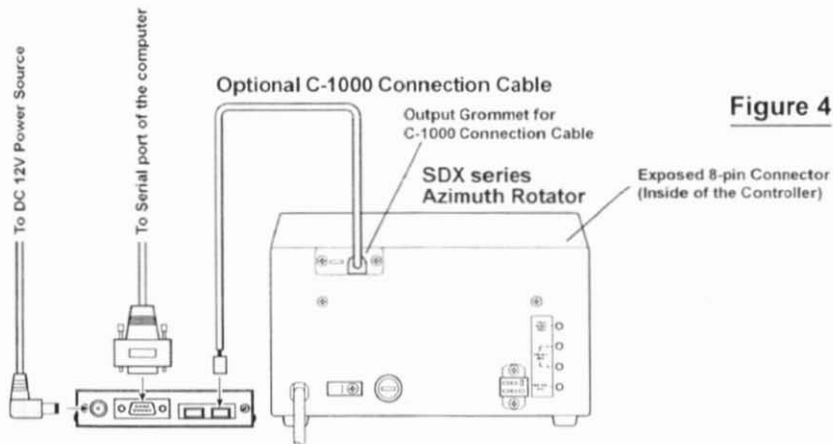
**Figure 4**

COMPUTER CONNECTION

- ❑ With the computer switched off, connect the DSUB-9 pin Straight RS-232C cable to the serial port of your computer, then connect the other end of the RS-232C cable to the **RS-232C** connector on the rear panel of the **GS-232B**.
- ❑ Turn the computer's power switch on, then turn the **GS-232B**'s power switch on.
- ❑ Within 15 seconds of swithing the **GS-232B**'s power, press the [↵] (ENTER) key several times to adjust the **GS-232B**'s data baud rate to the Computer's data baud rate. If the computer is successful to setting the data baud rate, the computer's diaplay will show "Connect OK."
- ❑ If you are using a **G-400** Azimuth Rotator, or **G-5400B/G-5600B** Az-EL Rotator, press [P36] → [↵] (P, 3, 6, and ENTER) on the computer keyboard to disable the 450° rotation capability of the **GS-232B**. To restore 450° rotation capability, press [P45] → [↵] (P, 4, 5, and ENTER) on the computer keyboard.

DXA/DXC/SDX SERIES AZIMUTH ROTATOR

Azimuth Offset Null

- From the Controller panel, set the Rotator fully counter-clockwise (set to 0°).
- Press [O] → [↵] (the letter "oh," and "ENTER") on the computer keyboard to activate the azimuth calibration routine. The computer display should show "are you sure?"
- Press [Y] → [↵] ("Y" and "ENTER") on the computer keyboard. The computer display should show "Completed," and save the calibration data and exit the azimuth calibration routine.

Azimuth A-D Calibration

- From the Controller panel, set the Rotator fully clockwise (to the right).
- Press [F] → [↵] ("F" and "ENTER") on the computer keyboard to activate the Control Interface's azimuth A-D converter calibration routine. The computer's display should show "AZ=aaa," where "aaa" is a three-digit number which indicates the azimuth heading in degrees.
- Adjust the **OUT VOL ADJ** potentiometer on Controller rear panel so as to get a reading of "450" on the computer's display. This reading ("450 degrees") corresponds to the actual beam heading you established when you pointed the azimuth rotator to the East.
- Press [↵] ("ENTER") on the computer keyboard to exit the azimuth A-D converter calibration routine.

Important Note !

If your controller's indicator needle starts from a point other than 0° (North) (such as the default setting of the USA version), align the starting point of the controller's indicator needle to 0° (North) before calibration. When finish the calibration, set the controller's indicator needle to the desired point. Refer to the rotator's user manual for details regarding the indicator needle alignment.

G-400 AZIMUTH ROTATOR

Azimuth Offset Null

- ❑ From the Controller panel, set the Rotator fully counter-clockwise (set to 0°).
- ❑ Press [O] → [↵] (the letter “oh,” and “ENTER”) on the computer keyboard to activate the azimuth calibration routine. The computer display should show “are you sure?”
- ❑ Press [Y] → [↵] (“Y” and “ENTER”) on the computer keyboard. The computer display should show “Completed,” and save the calibration data and exit the azimuth calibration routine.

Azimuth A-D Calibration

- ❑ From the Controller panel, set the Rotator fully clockwise (to the right).
- ❑ Press [F] → [↵] (“F” and “ENTER”) on the computer keyboard to activate the Control Interface’s azimuth A-D converter calibration routine. The computer’s display should show “AZ=aaa,” where “aaa” is a three-digit number which indicates the azimuth heading in degrees.
- ❑ Adjust the **FULL SCALE ADJ** on the **GX-500** so as to get a reading of “180” on the computer’s display. This reading (“180 degrees”) corresponds to the actual beam heading you established when you pointed the azimuth rotator to the South (the fully clockwise setting).
- ❑ Press [↵] (“ENTER”) on the computer keyboard to exit the azimuth A-D converter calibration routine.

G-5400B/-5600B AZ-EL ROTATOR

Azimuth Offset Null

- ❑ From the Controller panel, set the Rotator fully counter-clockwise (set to 0°).
- ❑ Press [O] → [↵] (the letter “oh,” and “ENTER”) on the computer keyboard to activate the azimuth calibration routine. The computer display should show “are you sure?”
- ❑ Press [Y] → [↵] (“Y” and “ENTER”) on the computer keyboard. The computer display should show “Completed,” and save the calibration data and exit the azimuth calibration routine.

Azimuth A-D Calibration

- ❑ From the Controller panel, set the Azimuth Rotator fully clockwise (to the right).
- ❑ Press [F] → [↵] (“F” and “ENTER”) on the computer keyboard to activate the Control Interface’s azimuth A-D converter calibration routine. The computer’s display should show “AZ=aaa,” where “aaa” is a three-digit number which indicates the azimuth heading in degrees.
- ❑ Adjust the **OUT VOL ADJ** potentiometer on the “**AZIMUTH**” (left) side of the Controller rear panel so as to get a reading of “180” on the computer’s display. This reading (“180 degrees”) corresponds to the actual beam heading you established when you pointed the azimuth rotator to the South.
- ❑ Press [↵] (“ENTER”) on the computer keyboard to exit the azimuth A-D converter calibration routine.

G-5400B/-5600B Az-EL ROTATOR

Elevation Offset Null

- ❑ From the Controller panel, set the Elevation Rotator to the “left” horizon (down, set to 0°).
- ❑ Press [O2] → [↵] (the letter “oh,” “2,” and “ENTER”) on the computer keyboard to activate the elevation calibration routine. The computer display should show “are you sure?”
- ❑ Press [Y] → [↵] (“Y” and “ENTER”) on the computer keyboard. The computer display should show “Completed,” and save the calibration data and exit the elevation calibration routine.

Elevation A-D Calibration

- ❑ From the Controller panel, set the Elevation Rotator to full scale (180°: “right” horizon).
- ❑ Press [F2] → [↵] (F, 2, and ENTER) on the computer keyboard to activate the Control Interface’s elevation A-D converter calibration routine. The computer will display “AZ=aaa EL=eee,” where “eee” is a three-digit number which indicates the elevation heading in degrees. For the purposes of this alignment, you may ignore the (azimuth) “aaa” numbers.
- ❑ Adjust the **OUT VOL ADJ** potentiometer on the “**EL-EVATION**” (right) side of the Controller rear panel so as to get a reading of “180” on the computer’s display. This reading (“180 degrees”) corresponds to the actual beam heading you established when you pointed the elevation rotator to the 180° position.
- ❑ Press [↵] (“ENTER”) on the computer keyboard to exit the elevation A-D converter calibration routine.

G-5500 Az-EL ROTATOR

Azimuth Offset Null

- From the Controller panel, set the Rotator fully counter-clockwise (set to 0°).
- Press [O] → [↵] (the letter “oh,” and “ENTER”) on the computer keyboard to activate the azimuth calibration routine. The computer display should show “are you sure?”
- Press [Y] → [↵] (“Y” and “ENTER”) on the computer keyboard. The computer display should show “Completed,” and save the calibration data and exit the azimuth calibration routine.

Azimuth A-D Calibration

- From the Controller panel, set the Azimuth Rotator fully clockwise (to the right).
- Press [F] → [↵] (F and ENTER) on the computer keyboard to activate the Control Interface’s azimuth A-D converter calibration routine. The computer’s display should show “AZ=aaa,” where “aaa” is a three-digit number which indicates the azimuth heading in degrees.
- Adjust the **OUT VOL ADJ** potentiometer on the “**AZIMUTH**” (left) side of the Controller rear panel so as to get a reading of “450” on the computer’s display. This reading (“450: 360 degrees + 90 degrees”) corresponds to the actual beam heading you established when you pointed the azimuth rotator fully clockwise.
- Press [↵] (“ENTER”) on the computer keyboard to exit the azimuth A-D converter calibration routine.

G-5500 AZ-EL ROTATOR

Elevation Offset Null

- ❑ Press [O2] → [↵] (the letter “oh,” “2,” and “ENTER”) on the computer keyboard to activate the elevation calibration routine. The computer display should show “are you sure?”
- ❑ Press [Y] → [↵] (“Y” and “ENTER”) on the computer keyboard. The computer display should show “Completed,” and save the calibration data and exit the elevation calibration routine.

Elevation A-D Calibration

- ❑ From the Controller panel, set the Elevation Rotator to full scal (180°: “right” horizon).
- ❑ Press [F2] → [↵] (F, 2, and ENTER) on the computer keyboard to activate the Control Interface’s elevation A-D converter calibration routine. The computer will display “AZ=aaa EL=eee,” where “eee” is a three-digit number which indicates the elevation heading in degrees. For the purposes of this alignment, you may ignore the (azimuth) “aaa” numbers.
- ❑ Adjust the **OUT VOL ADJ** potentiometer on the “**EL-EVATION**” (right) side of the Controller rear panel so as to get a reading of “180” on the computer’s display. This reading (“180 degrees”) corresponds to the actual beam heading you established when you pointed the elevation rotator to the 180° position.
- ❑ Press [↵] (“ENTER”) on the computer keyboard to exit the elevation A-D converter calibration routine.

G-500 ELEVATION ROTATOR

Elevation Offset Null

- ❑ Press [02] → [↵] (the letter “oh,” “2,” and “ENTER”) on the computer keyboard to activate the elevation calibration routine. The computer display should show “are you sure?”
- ❑ Press [Y] → [↵] (“Y” and “ENTER”) on the computer keyboard. The computer display should show “Completed,” and save the calibration data and exit the elevation calibration routine.

Elevation A-D Calibration

- ❑ From the Controller panel, set the Elevation Rotator to full scale (180°: “right” horizon).
- ❑ Press [F2] → [↵] (F, 2, and ENTER) on the computer keyboard to activate the Control Interface’s elevation A-D converter calibration routine. The computer will display “AZ=aaa EL=eee,” where “eee” is a three-digit number which indicates the elevation heading in degrees. For the purposes of this alignment, you may ignore the (azimuth) “aaa” numbers.
- ❑ Adjust the **OUT VOL ADJ** potentiometer on the **GX-500** so as to get a reading of “180” on the computer’s display. This reading (“180 degrees”) corresponds to the actual beam heading you established when you pointed the elevation rotator to the 180° position.
- ❑ Press [↵] (“ENTER”) on the computer keyboard to exit the elevation A-D converter calibration routine.

GENERAL

If you wish, you can mount the **GS-232B** on top of your Rotator Controller using the two supplied hook-and-loop fastener strips. Just remove the backing from one side of each strip, and press into place on the bottom of the **GS-232B**. Then remove the backing from the other side, and press the **GS-232B** into place on the Controller.

After installation and calibration, the Control Interface can accept commands entered directly from the keyboard, or from a program written specifically to support it (not supplied by Yaesu). For brief summaries of the commands recognized by the Control Interface, press [H] → [↵] for a list of azimuth commands, or [H2] → [↵] for elevations commands. Keep in mind that all commands require that the **ENTER** key be pressed after the command letter (or “ODh” be sent by a control program), although we will not repeat this when discussing the commands. Also note that any command letter may be sent in either upper or lower case. The info screens shown on the next page will be returned by the Control Interface.

Most commands have two versions: one for azimuth, and one for elevation. Commands are not echoed by the Control Interface, but a carriage return character (“ODh”) is returned after every command, and also a line feed character (“OAh”) if the command invoked returned data. Invalid commands cause “? >” to be returned and the input buffer cleared. Note that all angles are in degrees, beginning with zero at the most counterclockwise azimuth (or horizontal elevation). Angles sent to the Control Interface must be 3 digits long (left-zero-padded).

COMMAND LIST

In the following command descriptions, the elevation version of each command, where there is one, is shown in parentheses (but don't type the parentheses). Remember that elevation commands require the **G-5400B**, **G-5600B** or **G-5500** Az/El Rotators, or the **GX-500** adapter and the **G-500** or **G-550** Elevation Rotator.

O (O2)

Offset calibration for the Azimuth (Elevation): preset rotator manually fully counter-clockwise ("left" horizon for elevation), send command, and press [Y] → [↵] ("Y" and "ENTER") on the computer keyboard to store setting.

H (H2, H3)

Returns list of commands (see page 19 and 20).

F (F2)

Full Scale Calibration: preset rotator manually to full scale, send command, adjust **OUT VOL ADJ** trimmer on rear of controller (or **GX-500** elevation adapter) until the returned data is "+180 or +450" ("Onn+180" for elevation). Press [↵] ("ENTER") on the computer keyboard to exit the calibration routine.

R (U)

Start turning the rotator to the right (up)

L (D)

Start turning the rotator to the left (down).

A (E)

Stop azimuth (elevation) rotation.

S

Stop: cancel current command before completion.

C (B)

Return current azimuth (elevation) angle in the form "AZ=aaa" ("EL=eee" for "B" command) degrees.

C2

Return azimuth and elevation ("AZ=aaa EL=eee", where "aaa" = azimuth, "eee" = elevation).

P36

Switch the azimuth angle to 360 degree mode.

P45

Switch the azimuth angle to 450 degree mode.

Z

Toggle the starting point of the azimuth indicator needle between "N (North)" and "S (South)."

This command is ignored when the rotator is set to "450 degree mode."

COMMAND LIST

X n

Select azimuth rotator turning speed, where $n = 1$ (slowest) to 4 (fastest). This command can be issued during rotation, and takes effect immediately. There is no equivalent for elevation.

Maaa

Turn to *aaa* degrees azimuth, where *aaa* is a three-digit number between "000" and "360" or "450" (depending on rotator type). Rotation starts upon execution of the command.

Msss aaa bbb ccc

This command, together with the [T] command, provides automatic, timed tracking of moving objects or propagation by the Control Interface itself. This command stores the time value *sss* seconds to wait between stepping from azimuth *aaa* to *bbb*, and then to *ccc*, etc. (from "2" to as many as "3800" angles may be stored with one command).

Note that this command is completely different than the [T] command with only one parameter: when multiple parameters are present, the first one is interpreted by the Control Interface as the rotation interval *sss*, not an angle. Valid ranges are "001" to "999" for *sss*, and "000" to "360" or "450" (depending on rotator type) for the angles. When this command is sent, the parameters are stored in the Control Interface's RAM,

and the rotator turns to angle *aaa* and waits for a subsequent [T] command to begin the actual stepping. All numbers must be 3 digits, space-separated. Stored values remain in effect until another [M] command is issued (this may have no parameters, in which case the "?>" error prompt is returned, but memories are still cleared), or until the controller is turned off or by toggling the **GS-232B** off and on.

T

See the [M] (above) and the [W] (below) command. Start automatic stepping routine (both azimuth and elevation): turn rotator to next sequentially memorized azimuth (or az-el pair, for the [W] command), wait *sss* seconds, and turn to next angle (or pair), etc. This command works only if a long-form [M] or [W] has been issued since power-up or the last reset.

COMMAND LIST

N

Return serial number of currently selected memorized point [*nnnn*], and total number of memorized points [*mmmm*], in the form =*nnnn*=*mmmm*. Must be preceded by either a long-form [M] or [W], and a T command. Used only during stepping (see [T] command).

The meaning of a “point” in this command following an [M] command is only an azimuth angle, so in this case *nnnn* and *mmmm* can range up to “3800” (the limit defined in the EEPROM[×] in the Control Interface). However, when elevation is involved, a “point” following a [W] command is represented by both an azimuth and an elevation angle, in which case *nnnn* and *mmmm* can range up to only “1900,” since each “point” is a pair of angles.

× The EEP ROM may be written with up to one million data points.

Elevation Control Commands

These commands are only for az-el operation. Note that an azimuth angle must always be supplied when changing elevation, and that a setting point consists of a pair of angles.

Waaa eee

Turn to *aaa* degrees azimuth and *eee* degrees elevation, where *aaa* is a three-digit number between “000” and “360” or “450” (depending on rotator type) and *eee* is a three-digit number between “000” and “180.” Rotation starts upon execution of the command.

Wsss aaa eee aaa sss ...

This command is similar to the [M] command: the first parameter is a time interval, and succeeding parameters are angles. With this command, however, angles are in azimuth-elevation pairs, each pair representing one antenna location. At most “1900” pairs can be sent and stored in the Control Interface. As with the other commands, the time interval range is limited to “001” to “999” (seconds), azimuth to “000” to “360” or “450” (depending on rotator type), and elevation to “000” to “180.”

When this command is sent, the rotators turn to the first *aaa* azimuth parameter and the first *eee* elevation parameter, and wait for a subsequent [T] command to begin the actual stepping (to the next azimuth-elevation pair). Stored values

COMMAND LIST

remain in effect until another [W] command is issued (this may have no parameters, in which case the “?>” error prompt is returned, but memories are still cleared), or until the controller is turned off or by toggling the **GS-232B** off and on.

Returned by [H] Command:

----- COMMAND LIST 1 -----

- R Clockwise Rotation
- L Counter Clockwise Rotation
- A CW/CCW Rotation Stop
- C Antenna Direction Value
- M Antenna Direction Setting, MXXX
- M Time Interval Direction Setting,
MTTT XXX XXX XXX ---
[TTT = Step value]
[XXX = Horizontal Angle]
- T Start Command in the time interval direction setting mode.
- N Total number of setting angles in "M" mode and traced number of all datas (setting angles)
- S All Stop
- O Offset Calibration
- F Full Scale Calibration
- X1 Rotation Speed 1 (Horizontal) Low
- X2 Rotation Speed 2 (Horizontal) Middle 1
- X3 Rotation Speed 3 (Horizontal) Middle 2
- X4 Rotation Speed 4 (Horizontal) High

COMMAND LIST

Returned by [H2] Command:

----- HELP COMMAND 2 -----

- U UP Direction Rotation
- D DOWN Direction Rotation
- E UP/DOWN Direction Rotation Stop
- C2 Antenna Direction Value
- W Antenna Direction Setting.
WXXX YYY
- W Time Interval Direction Setting.
WTTT XXX YYY XXX YYY ---
(TTT = Step value)
(XXX = Horizontal Angle)
(YYY = Elevation Angle)
- T Start Command in the time interval direction setting mode.
- N Total number of setting angle in "W" mode and traced number of all datas (setting angles)
- S All Stop
- O2 Offset Calibration
- F2 Full Scale Calibration
- B Elevation Antenna Direction Value

Returned by [H3] Command:

----- HELP COMMAND 3 -----

- P45 Set_mode 450 Degree
- P36 Set_mode 360 Degree
- Z Swich N Center/S Center

----- MODE -----

- mode 450 Degree (or mode 360 Degree)
- N Center (or S Center)



Copyright 2004
VERTEX STANDARD CO., LTD.
All rights reserved.

No portion of this manual
may be reproduced
without the permission of
VERTEX STANDARD CO., LTD.

Printed in Japan

0401P-0E

