

YAESU FT-270R/E

Technical Supplement

©2010 VERTEX STANDARD CO., LTD. EH022N91B

VERTEX STANDARD CO., LTD.
4-8-8 Nakameguro, Meguro-Ku, Tokyo 153-8644, Japan

**VERTEX STANDARD
US Headquarters**
10900 Walker Street, Cypress, CA 90630, U.S.A.

YAESU UK LTD.
Unit 12, Sun Valley Business Park, Winnall Close
Winchester, Hampshire, SO23 0LB, U.K.

VERTEX STANDARD HK LTD.
Unit 5, 20/F., Seaview Centre, 139-141 Hoi Bun Road,
Kwun Tong, Kowloon, Hong Kong

VERTEX STANDARD (AUSTRALIA) PTY., LTD.
Normanby Business Park, Unit 14/45 Normanby Road
Notting Hill 3168, Victoria, Australia



Introduction

This manual provides the technical information necessary for servicing the **FT-270R/E** VHF FM Transceiver.

Servicing this equipment requires expertise in handling surface-mount chip components. Attempts by non-qualified persons to service this equipment may result in permanent damage not covered by the warranty, and may be illegal in some countries.

Two PCB layout diagrams are provided for each double-sided board in this transceiver. Each side of the board is referred to by the type of the majority of components installed on that side ("Side A" or "Side B"). In most cases one side has only chip components (surface-mount devices), and the other has either a mixture of both chip and leaded components (trimmers, coils, electrolytic capacitors, ICs, etc.), or leaded components only.

While we believe the information in this manual to be correct, VERTEX STANDARD assumes no liability for damage that may occur as a result of typographical or other errors that may be present. Your cooperation in pointing out any inconsistencies in the technical information would be appreciated.

Important Note

The transceiver was assembled using Pb (lead) free solder, based on the RoHS specification.

Only lead-free solder (Alloy Composition: Sn-3.0Ag-0.5Cu) should be used for repairs performed on this apparatus. The solder stated above utilizes the alloy composition required for compliance with the lead-free specification, and any solder with the above alloy composition may be used.

CAUTION

Risk of explosion if battery is replaced by an incorrect type. Dispose of used batteries according to the instructions.

Contents

Specifications	2
Exploded View & Miscellaneous Parts	3
Block Diagram	5
Circuit Description	7
Alignment	9
Board Units (Schematics, Layouts & Parts)	
Main Unit	13
FTD-7 DTMF Paging Unit (Option)	29

Specifications

General

Frequency Ranges:	RX 137 (136) - 174 MHz TX 144 - 146 (148) MHz
Channel Steps:	5/10/12.5/15/20/25/50/100 kHz
Frequency Stability:	±5 ppm @ -14° to +140° F (-10° to +60° C)
Repeater Shift:	±600 kHz
Emission Type:	F2D, F3E
Antenna Impedance:	50-ohm
Rating:	Battery Operation: 7.2 V DC 1.5 A Battery Charging: 12 V DC 1.5 A (EXT DC jack: PA-44C/U)
Supply Voltage:	Battery Operation: 7.2 V DC (FNB-83) Battery Charging: 12 V DC (EXT DC jack: PA-44C/U)
Current Consumption: (Approx. @7.2 V)	165 mA (Receive, 200 mW output) 45 mA (Standby, Saver Off) 20.5 mA (Standby, Saver On) 8 mA (Auto Power Off) 1.5 A (5 W TX 7.2 V DC)
Operating Temperature:	-4 °F to +140 °F (-20 °C to +60 °C)
Case Size:	2.36" (W) x 4.72" (H) x 1.26" (D) mm (60 x 120 x 32 mm) (W/O knob, antenna, & belt clip)
Weight:	13.8 Oz (390 g) with FNB-83, antenna, and belt clip

Transmitter

RF Power Output:	5.0 W (High) / 2.0 W (Middle) / 0.5 W (Low) (@7.2 V)
Modulation Type:	Variable Reactance F2D, F3E
Maximum Deviation:	±5.0 kHz (F2D, F3E)
Spurious Emission:	At least 60 dB below
Microphone Impedance:	2 k-ohm

Receiver

Circuit Type:	Double-Conversion Superheterodyne
Intermediate Frequencies:	1st: 21.7 MHz 2nd: 450 kHz
Sensitivity:	0.2 µV for 12 dB SINAD (137-140 MHz) 0.16 µV for 12 dB SINAD (140-150 MHz) 0.2 µV TYP for 12 dB SINAD (150-174 MHz)
Selectivity:	12 kHz/35 kHz (-6 dB /-60 dB)
AF Output: (@ 7.2 V)	800 mW @ 16-ohm for 10 % THD (Internal Speaker) 450 mW @ 8-ohm for 10 % THD (EXT SP Jack)

Specifications are subject to change without notice, and are guaranteed within the 144 MHz amateur band only. Frequency ranges and functions will vary according to transceiver version; check with your dealer.

Exploded View & Miscellaneous Parts

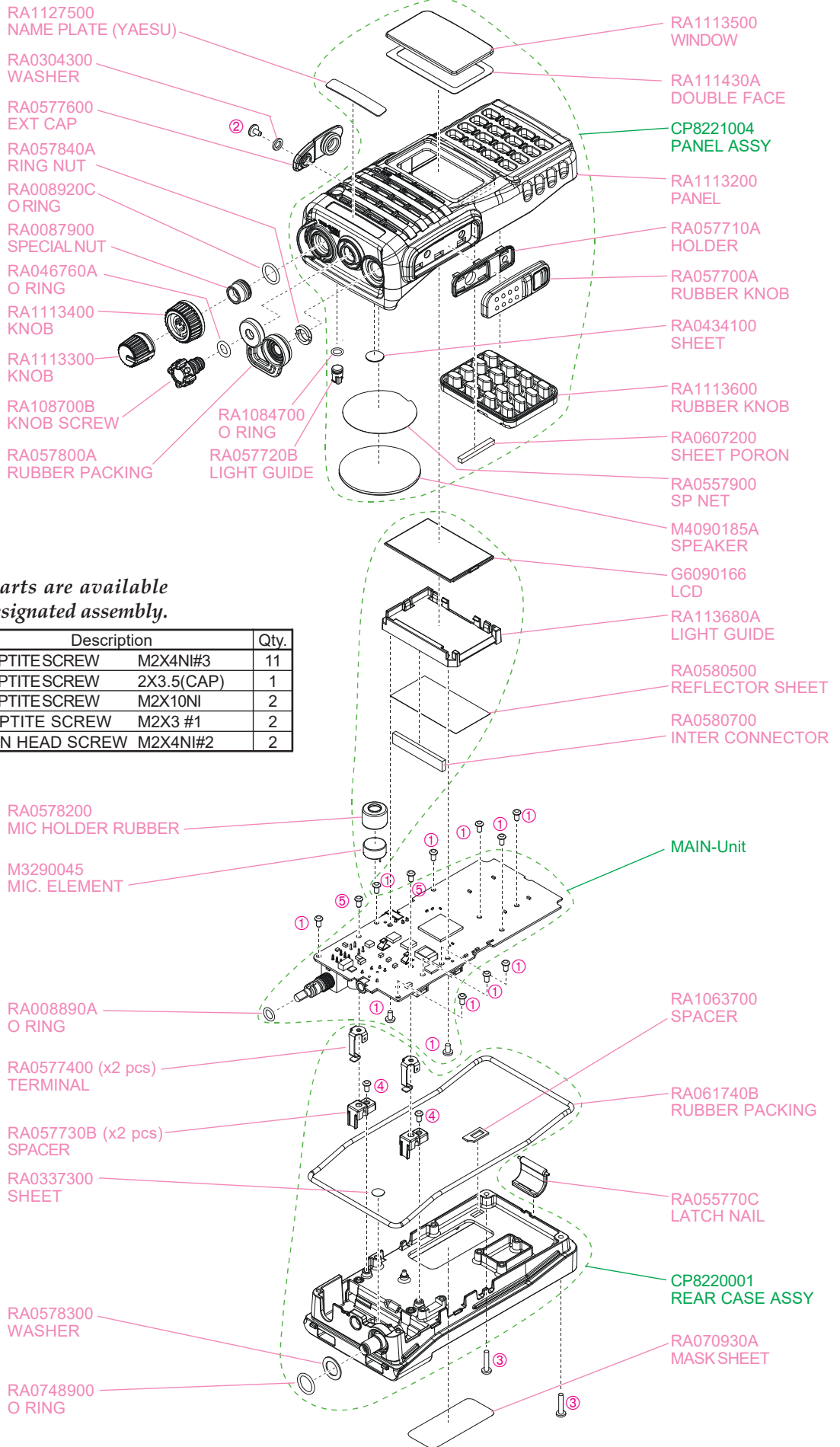

Non-designated parts are available only as part of a designated assembly.

Ref.	VXSTD P/N	Description	Qty.
①	U9900068	TAPTITE SCREW M2X4NI#3	11
②	U9900181	TAPTITE SCREW 2X3.5(CAP)	1
③	U24110002	TAPTITE SCREW M2X10NI	2
④	U9900035	TAPTITE SCREW M2X3 #1	2
⑤	U07240202	PAN HEAD SCREW M2X4NI#2	2

Exploded View & Miscellaneous Parts

Note

Block Diagram

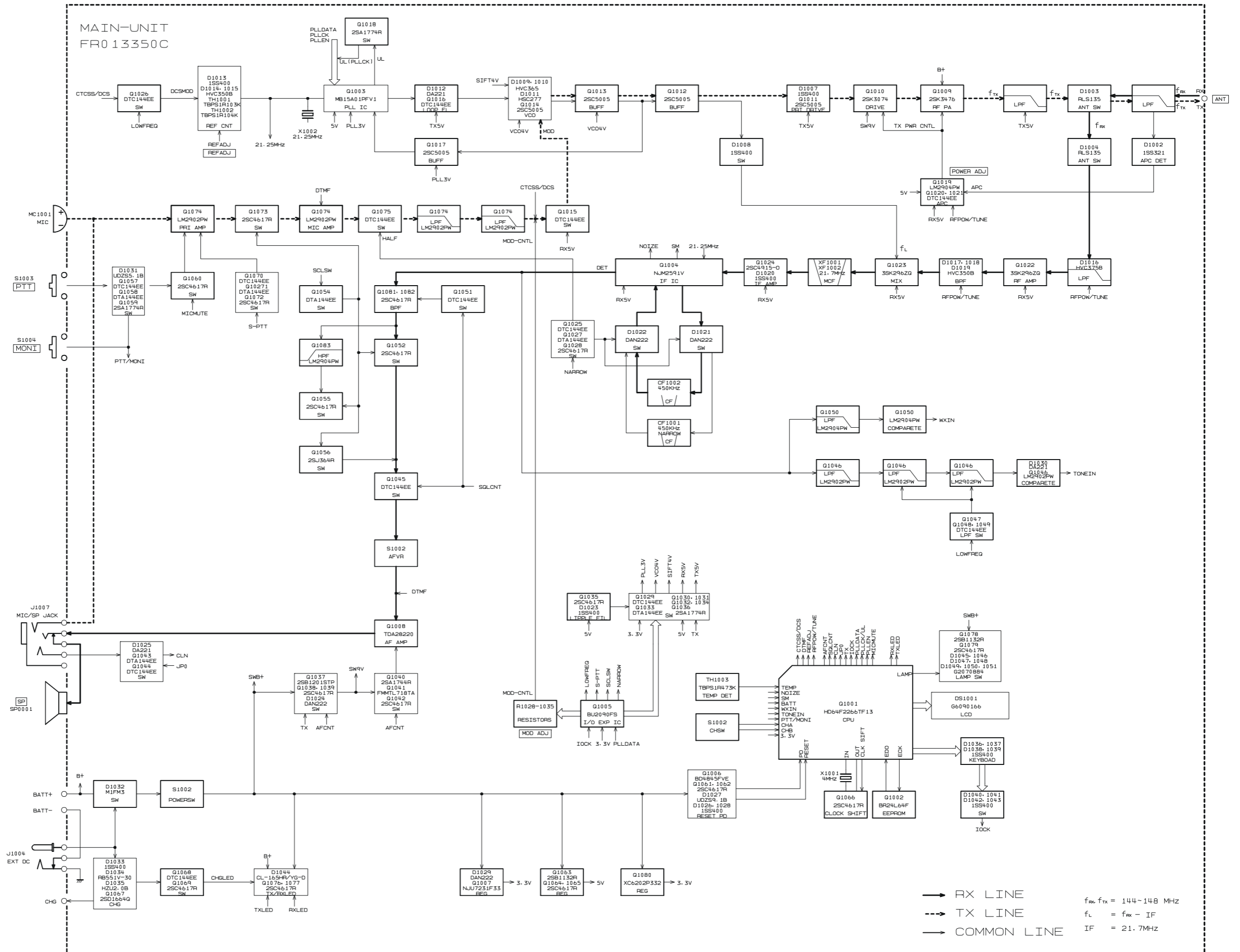

Block Diagram

Note

Receive Signal Path

Incoming RF signal from the antenna jack is delivered to the Main Unit and passed through the low-pass filter network, antenna switching diode **D1003** and **D1004** (both **RLS135**), and low-pass filter network to the RF amplifier **Q1022** (**3SK296ZQ**). The amplified RF signal is passed through band-pass filtered again by varactor-tuned band-pass filter consisting of coils L1024, L1025, and L1026, and diodes **D1017**, **D1018**, and **D1019** (all **HVC350B**), then applied to the 1st mixer **Q1023** (**3SK296ZQ**) along with the first local signal from the PLL circuit.

The first local signal is generated between 115.3 MHz and 152.3 MHz by the VCO, which consists of **Q1014** (**2SC5005**) and varactor diodes **D1009**, **D1010** (both **HVC365**) and **D1011** (**HSC277**) according to the receiving frequency.

IF and Audio Circuits

The 21.7 MHz first IF signal is applied to the monolithic crystal filters **XF1001** and **XF1002** which strip away unwanted mixer products, and the IF signal is applied to the first IF amplifier **Q1024** (**2SC4915**). The amplified first IF signal is then delivered to the FM IF subsystem IC **Q1004** (**NJM2591V**), which contains the second mixer, limiter amplifier, noise amplifier, and FM detector.

The second local signal is generated by 21.25 MHz crystal **X1002**, produces the 450 kHz second IF signal when mixed with first IF signal within **Q1004** (**NJM2591V**).

The 450 kHz second IF signal is applied to the ceramic filter **CF1001** or **CF1002** which strip away unwanted mixer products to the ceramic discriminator **CD1001** which removes any amplitude variations in the 450 kHz IF signal before detection of speech.

The detected audio from the **Q1004** (**NJM2591V**) is applied to a band-pass filter consisting of **Q1081** and **Q1082** (both **2SC4617**), then passes through the audio mute gate **Q1052** (**2SC4617**) and **Q1045** (**DTC144EE**).

The audio signal is passed through the audio VR which adjusts the audio sensitivity to compensate for audio level variations, then delivered to the audio amplifier **Q1008** (**TDA2822D**).

Squelch Control

When no carrier received, noise at the output of the detector stage in **Q1004** (**NJM2591V**) is applied to pin 49 of main CPU **Q1001** (**HD64F2266TF13**), which compares the squelch threshold level to that which set by the **SQL** knob. While no carrier is received, pin 71 of **Q1001** (**HD64F2266TF13**) remains "low," to disable audio output from the speaker.

Transmit Signal Path

The speech signal from the microphone is amplified by **Q1074** (**LM2902PWR**). The amplified speech signal is subjected to the low-pass filter network **Q1074** (**LM2902PWR**) and deviation controller **Q1075** (**DTC144EE**).

VHF Transmit Signal Path

The adjusted speech signal from **Q1075** (**DTC144EE**) is delivered to VCO **Q1014** (**2SC5005**) which frequency modulates the transmitting VCO made up of **D1010** (**HVC365**).

The modulated transmit signal passes through buffer amplifier **Q1013** and **Q1012** (both **2SC5005**).

The transmit signal applied to the Pre-Drive amplifier **Q1011** (**2SC5005**) and Drive amplifier **Q1010** (**2SK3074**), then finally amplified by Power amplifier **Q1009** (**2SK3476**) up to 5 Watts. This two stages (**Q1010** and **Q1009**) power amplifier's gain is controlled by the APC circuit.

The 5 Watts RF signal passes through low-pass filter network, antenna switch **D1003** (**RLS135**), and another low-pass filter network, and then deliver to the ANT jack.

Tx APC Circuit

A portion of the Power amplifier output is rectified by **D1002** (**1SS321**), then delivered to APC **Q1019** (**LM2904PWR**), **Q1020** and **Q1021** (both **DTC144EE**), as a DC voltage which is proportional to the output level of the power amplifier.

The APC **Q1019** (**LM2904PWR**) is compared the rectified DC voltage from the power amplifier and the reference voltage from the main CPU **Q1001** (**HD64F2266TF13**), to produce a control voltage, which regulates supply voltage to the Drive amplifier **Q1010** (**2SK3074**) and Power amplifier **Q1009** (**2SK3476**), so as to maintain stable output power under varying antenna loading condition.

PLL

A portion of the output from the VCO **Q1014** (**2SC5005**), passes through the buffer amplifier **Q1017** (**2SC5005**), then delivered to the programmable divider section of the PLL IC **Q1003** (**MB15A01PFV1**), which divided according to the frequency dividing data that is associated with the setting frequency input from the main CPU **Q1001** (**HD64F2266TF13**). It is then sent to the phase comparator.

The 21.25 MHz frequency of the reference oscillator circuit made up of **X1002** is divided by the reference frequency divider section of **Q1003** (**MB15A01PFV1**) into 4250 or 3400 parts to become 5 kHz or 6.25 kHz comparative reference frequencies, which are utilized by the phase comparator.

Circuit Description

The phase comparator section of **Q1003 (MB15A01PFV1)** compares the phase between the frequency-divided oscillation frequency of the VCO circuit and comparative frequency and its output is a pulse corresponding to the phase difference. This pulse is integrated by the charge pump and loop filter of **D1012 (DA221)** and **Q1016 (DTC144EE)** into a control voltage (VCV) to control the oscillation frequency of the VCO.

Introduction

The **FT-270R/E** is carefully aligned at the factory for the specified performance across the amateur band. Realignment should therefore not be necessary except in the event of a component failure. Only an authorized Vertex Standard representative should perform all component replacement and service, or the warranty policy may be void.

The following procedures cover the adjustments that are not normally required once the transceiver has left the factory. However, if damage occurs and some parts subsequently are replaced, realignment may be required. If a sudden problem occurs during normal operation, it is likely due to component failure; realignment should not be done until after the faulty component has been replaced.

We recommend that servicing be performed only by authorized Vertex Standard service technicians who are experienced with the circuitry and fully equipped for repair and alignment. If a fault is suspected, contact the dealer from whom the transceiver was purchased for instructions regarding repair. Authorized Vertex Standard service technicians realign all circuits and make complete performance checks to ensure compliance with factory specifications after replacing any faulty components.

Those who do undertake any of the following alignments are cautioned to proceed at their own risk. Problems caused by unauthorized attempts at realignment are not covered by the warranty policy. Also, Vertex Standard reserves the right to change circuits and alignment procedures in the interest of improved performance, without notifying owners.

Under no circumstances should any alignment be attempted unless the normal function and operation of the transceiver are clearly understood, the cause of the malfunction has been clearly pinpointed and any faulty components replaced, and realignment determined to be absolutely necessary.

Required Test Equipment

The following test equipment (and familiarity with its use) is necessary for complete realignment. Correction of problems caused by misalignment resulting from use of improper test equipment is not covered under the warranty policy. While most steps do not require all of the equipment listed, the interactions of some adjustments may require that more complex adjustments be performed afterwards.

Do not attempt to perform only a single step unless it is clearly isolated electrically from all other steps. Have all test equipment ready before beginning and, follow all of the steps in a section in the order presented.

- RF Signal Generator with calibrated output level at 200 MHz
- Deviation Meter (linear detector)
- In-line Wattmeter with 5% accuracy at 200 MHz
- 50-Ohm 10-W RF Dummy Load
- 8-Ohm AF Dummy Load
- Regulated DC Power Supply adjustable from 6 to 15 VDC, 2A
- Frequency Counter: 0.2-ppm accuracy at 200 MHz
- AF Signal Generator
- AC Voltmeter
- DC Voltmeter: high impedance
- VHF Sampling Coupler
- SINAD Meter

Alignment Preparation & Precautions

A 50-Ohm RF load and in-line wattmeter must be connected to the main antenna jack in all procedures that call for transmission; alignment is not possible with an antenna. After completing one step, read the next step to see if the same test equipment is required. If not, remove the test equipment (except dummy load and wattmeter, if connected) before proceeding.

Correct alignment requires that the ambient temperature be the same as that of the transceiver and test equipment, and that this temperature be held constant between 68 ~ 86° F (20° ~ 30° C). When the transceiver is brought into the shop from hot or cold air, it should be allowed some time to come to room temperature before alignment. Whenever possible, alignments should be made with oscillator shields and circuit boards firmly affixed in place. Also, the test equipment must be thoroughly warmed up before beginning.

Note: Signal levels in dB referred to in the alignment procedure are based on $0\text{dB}\mu = 0.5\mu\text{V}$.

Alignment

Test Setup

Set up the test equipment as shown below for transceiver alignment.

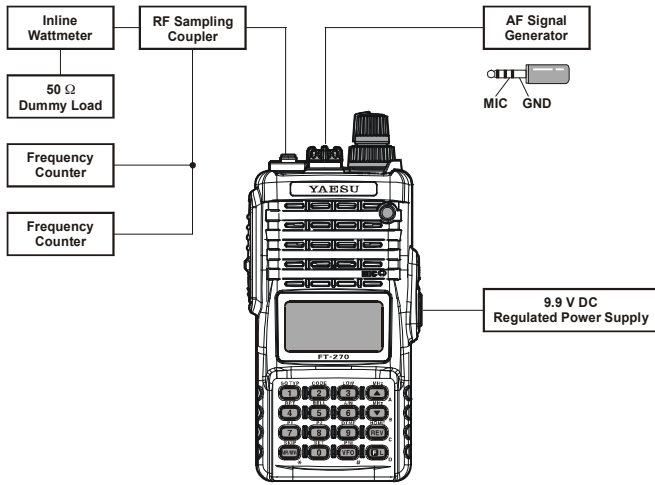

"TX SECTION" ALIGNMENT SETUP

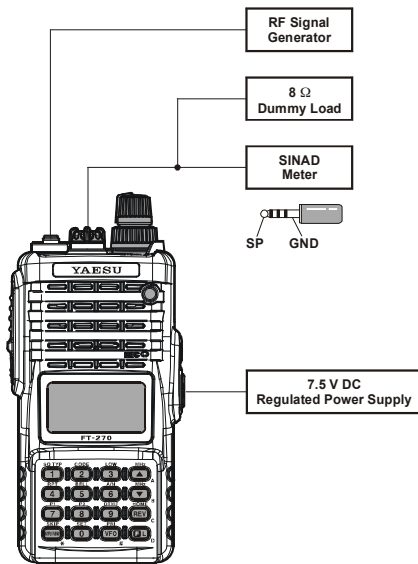

"RX SECTION" ALIGNMENT SETUP

Entering the Alignment Mode

Alignment of the **FT-270R/E** is performed using a front panel software-based procedure. To perform alignment of the transceiver, it must first be placed in the "Alignment Mode," in which the adjustments will be made and then stored into memory.

To enter the Alignment mode:

1. Rotate the [**VOL/PWR**] knob (inner knob) out of the click-stop to turn on the radio.
2. Rotate the **DIAL** knob to select the frequency to 145.050 MHz.
3. Turn the power off by rotating the [**VOL/PWR**] knob fully counter clockwise.
4. Press and hold in the [**VFO(PRI)**] key turning the radio on. Once the radio is on, release the key.
5. Turn the power off by rotating the [**VOL/PWR**] knob fully counter clockwise.
6. Press and hold in the **PTT** and **MONI** switches turning the radio on. Once the radio is on, release these two switches.
7. Press the keypad in the following sequence:
[**▲(MHz)**] → [**0(SET)**] → [**2(CODE)**] → [**2(CODE)**] → [**MR/MW(SKIP)**]
8. Press the [**F**] key to cause "AO REF.xxx" to appear on the display for five seconds, this signifies that the transceiver is now in the "Alignment Mode."

PLL Reference Frequency

1. Rotate the **DIAL** knob to select the display to "B0106." Press the [**F**] key, then press the [**MR/MW(SKIP)**] key to set the alignment, then set the transmit power level to "LOW."
2. Press the [**F**] key, then press the [**MR/MW(SKIP)**] key to set the alignment parameter to "AO REF.xxx," if needed.
3. Within five seconds of appearing the "AO REF.xxx" on the display, press the **PTT** switch to activate the transmitter, adjust the **DIAL** knob so that the counter frequency reading is 145.050 MHz (± 100 Hz).

RF Front-end Tuning

1. Connect the DC voltmeter to **TP1031** on the MAIN unit, then inject a 145.050 MHz signal at a level of +10 dB μ (with 1 kHz modulation @ \pm 3.5 kHz deviation) from the RF signal generator.
2. Rotate the **DIAL** knob to select the display to "B0106."
3. Press the [F/W] key, then press the [MR/MW(SKIP)] key to set the alignment parameter to "A1 TUN.xxx."
4. Within five seconds of appearing the "A1 TUN.xxx" on the display, adjust the **DIAL** knob so that the DC voltmeter reaches maximum deflection. The **FT-270R** RF Front-end has a broad bandwidth. Therefore, prior to adjustment you must adjust the **DIAL** knob to set the frequency to the middle of the band, in step 2, so you can set peak in the DC voltmeter's deflection in the center of the RF passband.

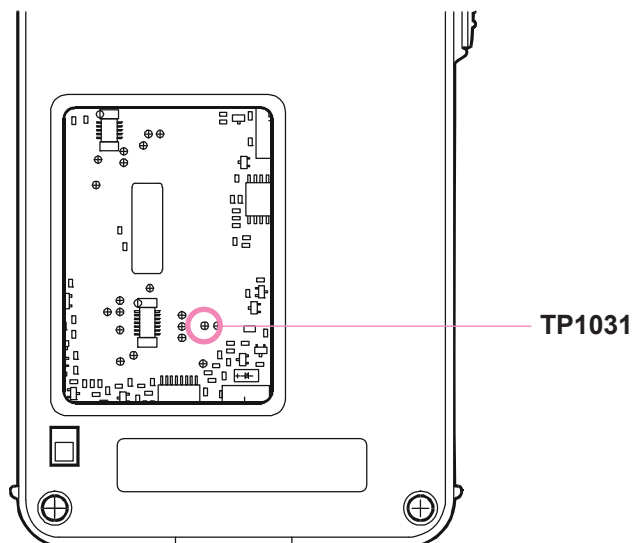

TX Power Output

1. Rotate the **DIAL** knob to select the display to "B0206," then set the transmit power level to "LOW."
2. Press the [F/W] key, then press the [MR/MW(SKIP)] key to set the alignment parameter to "A2 PWR.xxx."
3. Within five seconds of appearing the "A2 PWR.xxx" on the display, press the **PTT** switch to activate the transmitter, adjust the **DIAL** knob so that the wattmeter reading is 0.5 Watts (\pm 0.05 Watt).
4. Increase the Transmit power level to "MID."
5. Press the [F/W] key to recall the alignment parameter "A2 PWR.xxx."
6. Within five seconds of appearing the "A2 PWR.xxx" on the display, press the **PTT** switch to activate the transmitter, adjust the **DIAL** knob so that the wattmeter reading is 2.0 Watts (\pm 0.1 Watt).
7. Increase the Transmit power level to "HIGH."
8. Press the [F/W] key to recall the alignment parameter "A2 PWR.xxx."
9. Within five seconds of appearing the "A2 PWR.xxx" on the display, press the **PTT** switch to activate the transmitter, adjust the **DIAL** knob so that the wattmeter reading is 5.0 Watts (\pm 0.1 Watt).

TX Deviation

1. Rotate the **DIAL** knob to select the display to "B0206," then set the transmit power level to "LOW."
2. Press the [F/W] key, then press the [MR/MW(SKIP)] key to set the alignment parameter to "A3 DEV.xxx."
3. Within five seconds of appearing the "A3 DEV.xxx" on the display, press the **PTT** switch to activate the transmitter, adjust the **DIAL** knob so that the deviation meter reading is 4.2 kHz (\pm 0.2 kHz) (EXP version: 4.5 kHz \pm 0.2 kHz).

DCS TX Deviation

1. Rotate the **DIAL** knob to select the display to "B0206," then activate the DCS, and set the transmit power level to "LOW."
2. Press the [F/W] key, then press the [MR/MW(SKIP)] key to set the alignment parameter to "A4 DCS.xxx."
3. Within five seconds of appearing the "A4 DCS.xxx" on the display, press the **PTT** switch to activate the transmitter (with no microphone input), adjust the **DIAL** knob so that the deviation meter reading is 0.7 kHz (\pm 0.05 kHz).

Alignment

CTCSS TX Deviation

1. Rotate the **DIAL** knob to select the display to “B0206,” then activate the CTCSS encoder with a “100 Hz” tone, and set the transmit power level to “LOW.”
2. Press the [**F/W**] key, then press the [**MR/MW(SKIP)**] key to set the alignment parameter to “A5 CTC.xxx.”
3. Within five seconds of appearing the “A5 CTC.xxx” on the display, press the **PTT** switch to activate the transmitter (with no microphone input), adjust the **DIAL** knob so that the deviation meter reading is 0.7 kHz (± 0.05 kHz).

S-meter Sensitivity

1. Rotate the **DIAL** knob to select the display to “B0206.”
2. Inject a 146.050 MHz signal at a level of -5 dB μ V (with 1 kHz modulation @ ± 3.5 kHz deviation) from the RF signal generator.
3. Press the [**F/W**] key, then press the [**MR/MW(SKIP)**] key to set the alignment parameter to “A6 SM U/D.”
4. Within five seconds of appearing the “A6 SM U/D” on the display, press the [**▼(MHz)**] key.
5. Increase the RF signal generator output level to $+23$ dB μ V.
6. Press the [**F/W**] key to recall the alignment parameter to “A6 SM U/D.”
7. Within five seconds of appearing the “A6 SM U/D” on the display, press the [**▲(MHz)**] key.

Squelch Sensitivity

1. Rotate the **DIAL** knob to select the display to “B0206.”
2. Inject a 146.050 MHz signal at a level of -12 dB μ V (with 1 kHz modulation @ ± 3.5 kHz deviation) from the RF signal generator.
3. Press the [**F/W**] key, then press the [**MR/MW(SKIP)**] key to set the alignment parameter to “A7 SQL U/D.”
4. Within five seconds of appearing the “A7 SQL U/D” on the display, press the [**▼(MHz)**] key.
5. Increase the RF signal generator output level to -3 dB μ V.
6. Press the [**F/W**] key to recall the alignment parameter to “A7 SQL U/D.”
7. Within five seconds of appearing the “A7 SQL U/D” on the display, press the [**▲(MHz)**] key.

DC Voltmeter

1. Set the power supply voltage to 9.9 V.
2. Press the [**F/W**] key, then press the [**MR/MW(SKIP)**] key to set the alignment parameter to “A8 BAT RV.”
3. Within five seconds of appearing the “A8 BAT RV” on the display, press the [**REV(HOME)**] key.

To close the alignment mode

1. Turn the power off by rotating the [**VOL/PWR**] knob fully counter clockwise.
2. The next time the transceiver is turned on, press and hold in the [**VFO(PRI)**] key turning the radio on. Once the radio is on, release the key. normal operation may resume.

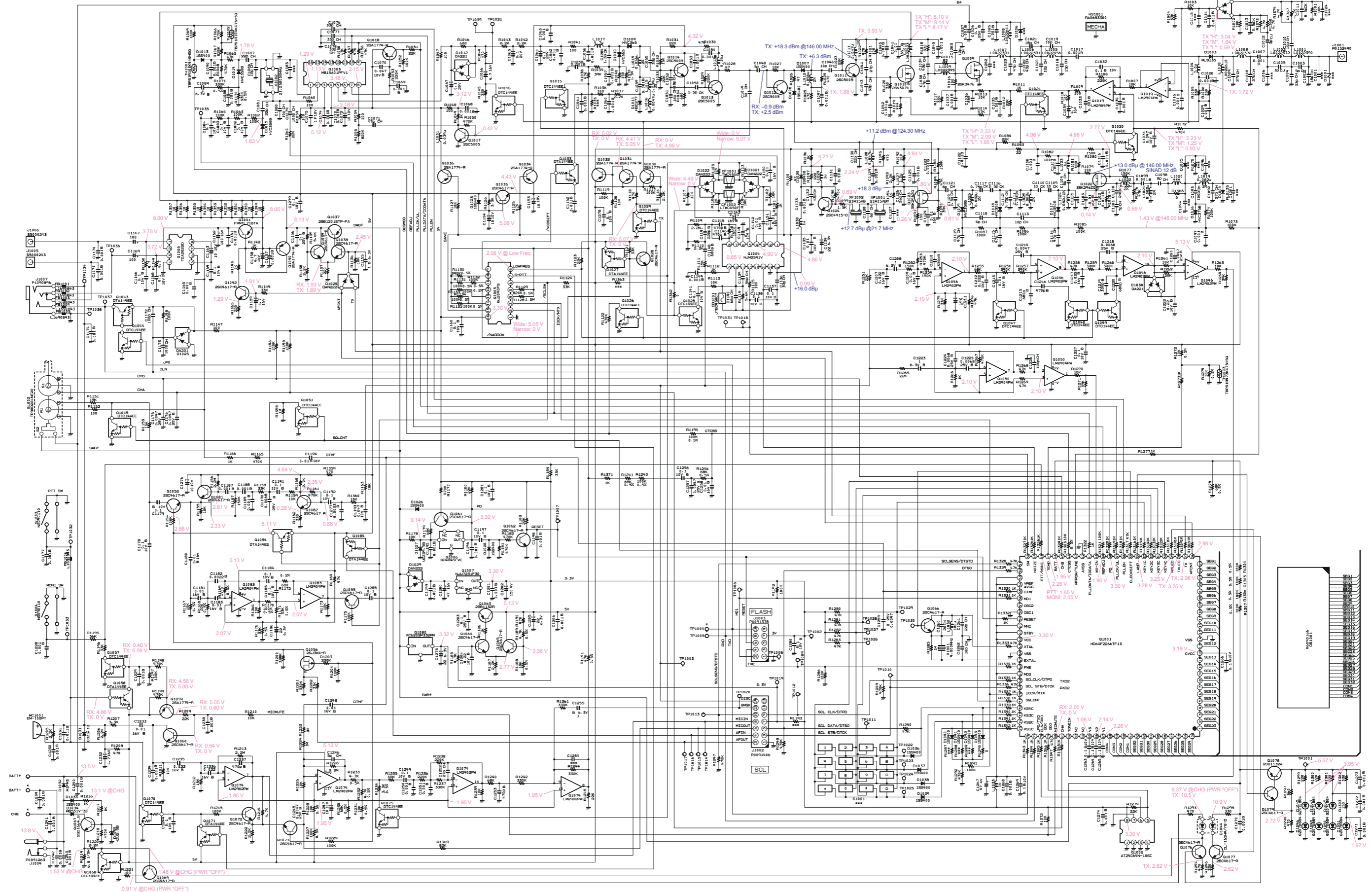

MAIN Unit

Note

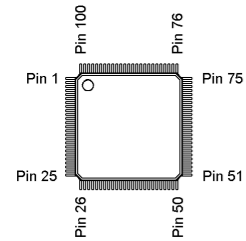
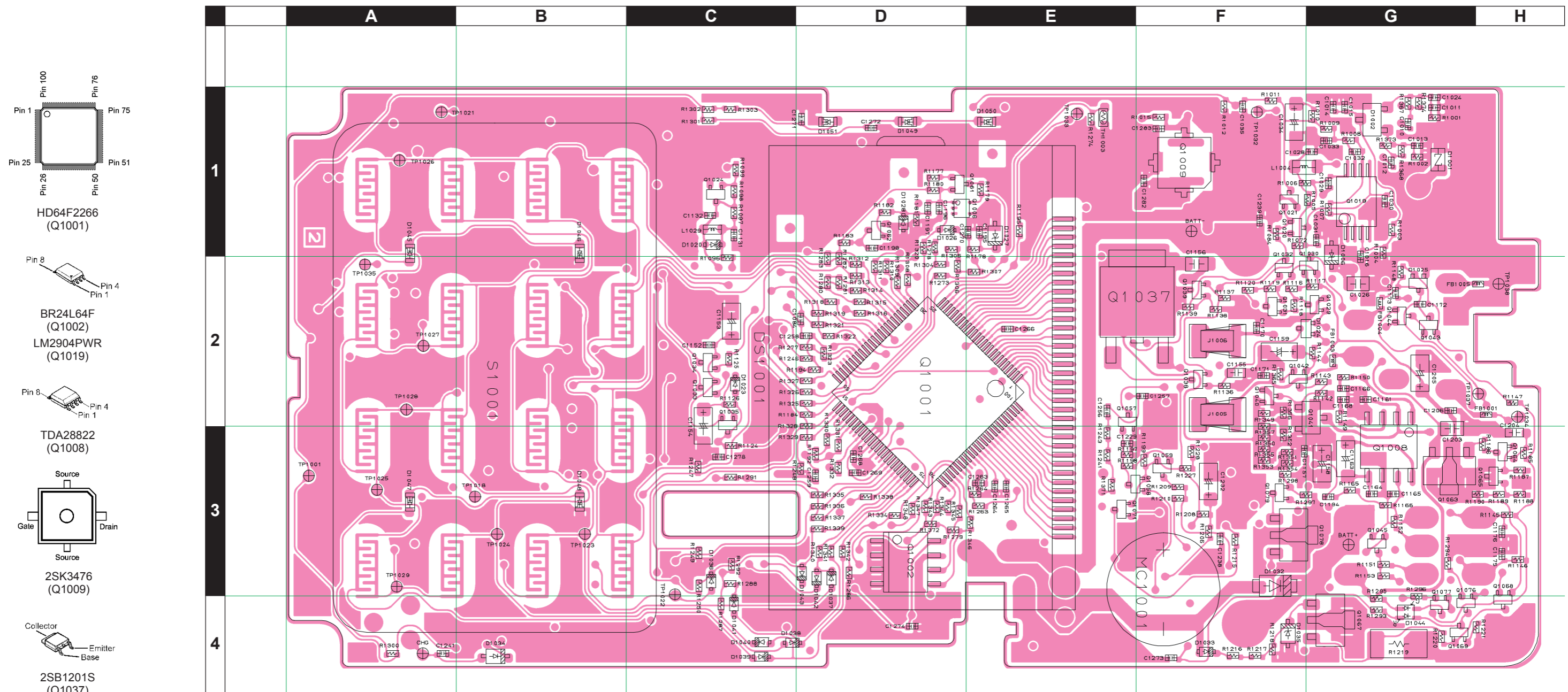

HD64F2266 (Q1001)

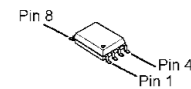

BR24L64F (Q1002)
LM2904PWR (Q1019)



TDA28822 (Q1008)

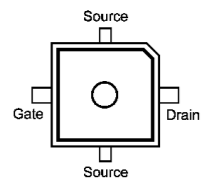

2SK3476 (Q1009)

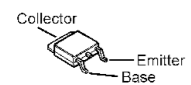

2SB1201S (Q1037)

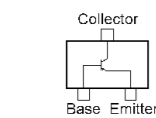

2SA1774 (FR)
(Q1030, 1031, 1032, 1034, 1040, 1059)

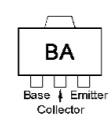

2SB1132 (BA)
(Q1063, 1078)

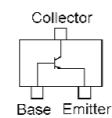

2SC4617 (BR)
(Q1034, 1038, 1039, 1042, 1061, 1062, 1064, 1065, 1069, 1076, 1077, 1079)

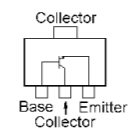

2SD1664 (DA)
(Q1067)

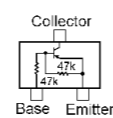

DTA144EE (16)
(Q1033, 1043, 1058, 1071)

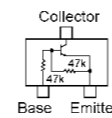

DTC144EE (26)
(Q1020, 1021, 1029, 1044, 1045, 1057, 1068)

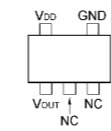

BD4845FVE (Q1006)

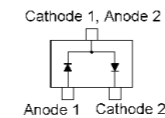

DA221 (K)
(D1025)

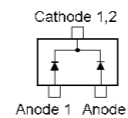

1SS321 (F9)
(D1002)
DAN222 (N)
(D1024)

MAIN Unit

Parts Layout (Side B)

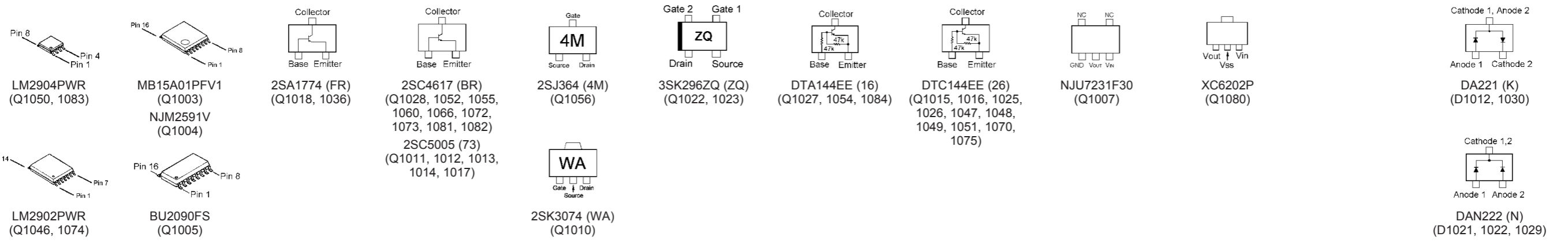
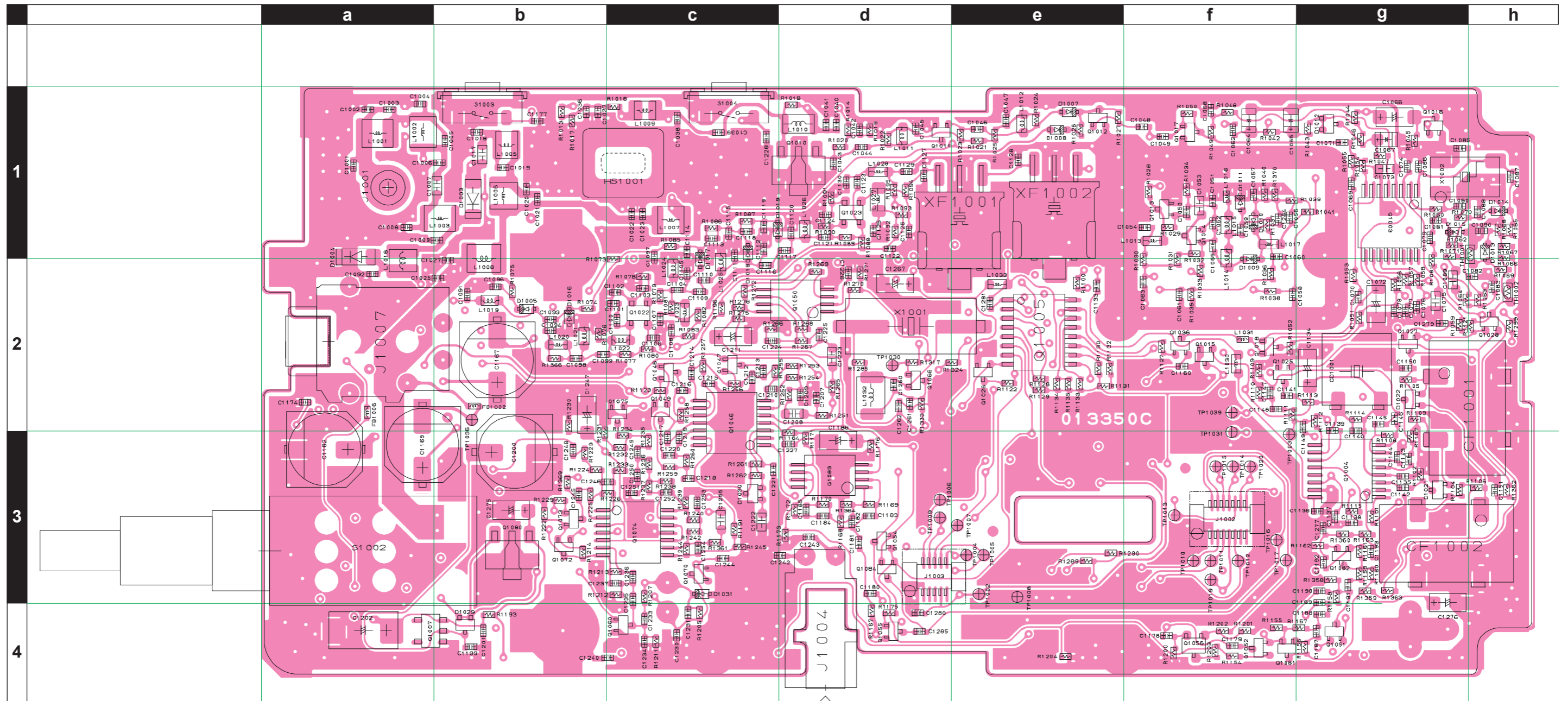

REF	DESCRIPTION	VALUE	V/W	TOL.	MFR'S DESIG	VXSTD P/N	VERS.	LOT	SIDE	LAY ADR
PCB with Components						CB3164015	VX-270R USA A2			
						CB3164016	VX-270R EXP A1			
						CB3164017	VX-270R EXP A2			
						CB3164018	VX-270R EXP A3			
						CB3164019	VX-270E EXP B1			
						CB3164020	VX-270E EXP B2			
						CB3164021	VX-270R EXP B3			
Printed Circuit Board						FR013350C		1-		
C 1002	CHIP CAP.	15pF	50V	CH	GRM1552C1H150JZ01D	K22178216		1-	B	a1
C 1003	CHIP CAP.	5pF	50V	CH	GRM1552C1H5R0BZ01D	K22178292		1-	B	a1
C 1004	CHIP CAP.	33pF	50V	CH	GRM1552C1H330JZ01D	K22178224		1-	B	a1
C 1005	CHIP CAP.	3pF	50V	CJ	GRM1553C1H3R0BZ01D	K22178290		1-	B	b1
C 1006	CHIP CAP.	2pF	50V	CK	GRM1554C1H2R0BZ01D	K22178289		9-	B	b1
C 1007	CHIP CAP.	0.001uF	50V	B	GRM188B11H102KA01D	K22174821		1-	B	b1
C 1008	CHIP CAP.	27pF	50V	CH	GRM1552C1H270JZ01D	K22178222		1-	B	a1
C 1009	CHIP CAP.	27pF	50V	CH	GRM1552C1H270JZ01D	K22178222		1-	B	b1
C 1010	CHIP CAP.	10pF	50V	CH	GRM1552C1H100BZ01D	K22178297		1-	A	G1
C 1011	CHIP CAP.	0.5pF	50V	CK	GRM1554C1HR50BZ01D	K22178285		1-	A	G1
C 1012	CHIP CAP.	3pF	50V	CJ	GRM1553C1H3R0BZ01D	K22178290		1-	A	G1
C 1013	CHIP CAP.	0.5pF	50V	CK	GRM1554C1HR50BZ01D	K22178285		1-	A	G1
C 1014	CHIP CAP.	0.001uF	50V	B	GRM155B11H102KA01D	K22178809		1-	A	G1
C 1016	CHIP CAP.	0.001uF	50V	B	GRM155B11H102KA01D	K22178809		1-	A	G1
C 1017	CHIP CAP.	0.001uF	50V	B	GRM188B11H102KA01D	K22174821		1-	B	b1
C 1018	CHIP CAP.	15pF	50V	CH	GRM1552C1H150JZ01D	K22178216		1-	B	b1
C 1019	CHIP CAP.	10pF	50V	CH	GRM1552C1H100BZ01D	K22178297		1-	B	b1
C 1020	CHIP CAP.	12pF	50V	CH	GRM1552C1H120JZ01D	K22178214		1-	B	b1
C 1021	CHIP CAP.	18pF	50V	CH	GRM1552C1H180JZ01D	K22178218		1-	B	b1
C 1022	CHIP CAP.	43pF	50V	CH	GRM1552C1H430JD01D	K22178227		1-	B	c1
C 1023	CHIP CAP.	47pF	50V	CH	GRM1552C1H470JZ01D	K22178228		1-	B	c1
C 1025	CHIP CAP.	0.001uF	50V	B	GRM155B11H102KA01D	K22178809		1-	B	b2
C 1026	CHIP CAP.	0.1uF	25V	B	GRM21BB11E104KA01L	K22140811		1-	A	G2
C 1027	CHIP CAP.	0.001uF	50V	B	GRM155B11H102KA01D	K22178809		1-	B	b1
C 1028	CHIP CAP.	0.001uF	50V	B	GRM155B11H102KA01D	K22178809		1-	A	G1
C 1029	CHIP CAP.	0.001uF	50V	B	GRM155B11H102KA01D	K22178809		1-	A	G1
C 1030	CHIP CAP.	0.001uF	50V	B	GRM155B11H102KA01D	K22178809		1-	A	G1
C 1031	CHIP CAP.	0.047uF	10V	B	GRM155B11A473KA01D	K22108801		1-	A	G1
C 1032	CHIP CAP.	0.1uF	10V	B	GRM155B11A104KA01D	K22108802		1-	A	G1
C 1033	CHIP CAP.	0.001uF	50V	B	GRM155B11H102KA01D	K22178809		1-	A	G1
C 1034	CHIP TA.CAP.	4.7uF	16V		TEESVA1C475M8R	K78120031		1-	A	F1
C 1035	CHIP CAP.	0.001uF	50V	B	GRM155B11H102KA01D	K22178809		1-	A	F1
C 1037	CHIP CAP.	0.001uF	50V	B	GRM155B11H102KA01D	K22178809		1-	B	b1
C 1038	CHIP CAP.	47pF	50V	CH	GRM1552C1H470JZ01D	K22178228		1-	B	c1
C 1039	CHIP CAP.	43pF	50V	CH	GRM1552C1H430JD01D	K22178227		1-	B	c1
C 1040	CHIP CAP.	0.001uF	50V	B	GRM155B11H102KA01D	K22178809		1-	B	d1
C 1041	CHIP CAP.	0.01uF	16V	B	GRM36B103K16PT	K22128804		1-	B	d1
C 1041	CHIP CAP.	0.01uF	25V	B	GRM155B11E103KA01D	K22148834		28-	B	d1
C 1042	CHIP CAP.	0.001uF	50V	B	GRM155B11H102KA01D	K22178809		1-	B	d1
C 1043	CHIP CAP.	33pF	50V	CH	GRM1552C1H330JZ01D	K22178224		1-	B	d1
C 1044	CHIP CAP.	27pF	50V	CH	GRM1552C1H270JZ01D	K22178222		1-	B	d1
C 1045	CHIP CAP.	0.001uF	50V	B	GRM155B11H102KA01D	K22178809		1-	B	d1
C 1046	CHIP CAP.	10pF	50V	CH	GRM1552C1H100BZ01D	K22178297		1-	B	e1
C 1047	CHIP CAP.	0.001uF	50V	B	GRM155B11H102KA01D	K22178809		1-	B	e1
C 1048	CHIP CAP.	5pF	50V	CH	GRM1552C1H5R0BZ01D	K22178292		1-	B	f1
C 1049	CHIP CAP.	5pF	50V	CH	GRM1552C1H5R0BZ01D	K22178292		1-	B	f1
C 1050	CHIP CAP.	1.5pF	50V	CK	GRM1554C1H1R5BZ01D	K22178288		1-	B	f1
C 1051	CHIP CAP.	18pF	50V	CH	GRM1552C1H180JZ01D	K22178218		1-	B	f1
C 1052	CHIP CAP.	18pF	50V	CH	GRM1552C1H180JZ01D	K22178218		1-	B	f1
C 1053	CHIP CAP.	0.001uF	50V	B	GRM188B11H102KA01D	K22174821		1-	B	f1
C 1054	CHIP CAP.	0.001uF	50V	B	GRM155B11H102KA01D	K22178809		1-	B	f1
C 1055	CHIP CAP.	33pF	50V	CH	GRM1552C1H330JZ01D	K22178224		1-	B	f1
C 1056	CHIP CAP.	0.001uF	50V	B	GRM155B11H102KA01D	K22178809		1-	B	f1
C 1057	CHIP CAP.	0.001uF	50V	B	GRM155B11H102KA01D	K22178809		1-	B	f1
C 1058	CHIP CAP.	0.001uF	50V	B	GRM155B11H102KA01D	K22178809		1-	B	f2
C 1059	CHIP CAP.	0.001uF	50V	B	GRM155B11H102KA01D	K22178809		1-	B	f1
C 1060	CHIP CAP.	0.001uF	50V	B	GRM155B11H102KA01D	K22178809		1-	B	f1
C 1061	CHIP CAP.	0.001uF	50V	B	GRM155B11H102KA01D	K22178809		1-	B	f2
C 1062	CHIP CAP.	0.001uF	50V	B	GRM155B11H102KA01D	K22178809		1-	B	f1
C 1063	CHIP CAP.	0.001uF	50V	B	GRM155B11H102KA01D	K22178809		1-	B	f2
C 1064	CHIP TA.CAP.	0.1uF	20V		SKF-1D104M-RP	K78130049		1-	B	f1
C 1065	CHIP TA.CAP.	0.1uF	20V		SKF-1D104M-RP	K78130049		1-	B	f1
C 1066	CHIP TA.CAP.	4.7uF	16V		TEESVA1C475M8R	K78120031		1-	B	g1
C 1067	CHIP TA.CAP.	0.1uF	20V		SKF-1D104M-RP	K78130049		1-	B	g1
C 1068	CHIP CAP.	0.001uF	50V	B	GRM155B11H102KA01D	K22178809		1-	B	f1

MAIN Unit

Parts List

REF	DESCRIPTION	VALUE	V/W	TOL.	MFR'S DESIG	VXSTD P/N	VERS.	LOT	SIDE	LAY ADR
C 1069	CHIP CAP.	0.001uF	50V	B	GRM155B11H102KA01D	K22178809		1-	B	g1
C 1070	CHIP CAP.	0.047uF	10V	B	GRM155B11A473KA01D	K22108801		1-	B	g2
C 1071	CHIP CAP.	47pF	50V	CH	GRM1552C1H470JZ01D	K22178228		1-	B	g1
C 1072	CHIP TA.CAP.	10uF	10V		TEESVA1A106M8R	K78100028		1-	B	g2
C 1073	CHIP CAP.	0.001uF	50V	B	GRM188B11H102KA01D	K22174821		1-	B	g1
C 1074	CHIP CAP.	0.001uF	50V	B	GRM155B11H102KA01D	K22178809		1-	B	g1
C 1075	CHIP CAP.	1uF	10V	F	GRM188F11A105ZA01D	K22105001		1-	B	g2
C 1076	CHIP CAP.	33pF	50V	CH	GRM1552C1H330JZ01D	K22178224		1-	B	g2
C 1077	CHIP CAP.	33pF	50V	CH	GRM1552C1H330JZ01D	K22178224		1-	B	g2
C 1078	CHIP CAP.	33pF	50V	CH	GRM1552C1H330JZ01D	K22178224		1-	B	g2
C 1079	CHIP CAP.	100pF	50V	CH	GRM1552C1H101JD01D	K22178236		1-	B	g1
C 1080	CHIP CAP.	10pF	50V	CH	GRM1552C1H100BZ01D	K22178297		1-	B	g1
C 1080	CHIP CAP.	9pF	50V	CH	GRM1552C1H9R0BZ01D	K22178296		53-	B	g1
C 1081	CHIP CAP.	22pF	50V	CH	GRM1552C1H220JZ01D	K22178220		1-	B	g1
C 1082	CHIP CAP.	0.1uF	10V	B	GRM155B11A104KA01D	K22108802		1-	B	h2
C 1083	CHIP CAP.	0.1uF	10V	B	GRM155B11A104KA01D	K22108802		1-	B	h2
C 1084	CHIP CAP.	0.1uF	10V	B	GRM155B11A104KA01D	K22108802		1-	A	D2
C 1086	CHIP CAP.	10pF	50V	CH	GRM1552C1H100BZ01D	K22178297		1-	B	g1
C 1087	CHIP CAP.	22pF	50V	CH	GRM1552C1H220JZ01D	K22178220		1-	B	h1
C 1088	CHIP CAP.	0.001uF	50V	B	GRM155B11H102KA01D	K22178809		1-	B	h1
C 1089	CHIP CAP.	1uF	6.3V	B	GRM188B10J105KA01D	K22084801		1-	B	g2
C 1090	CHIP CAP.	0.001uF	50V	B	GRM155B11H102KA01D	K22178809		1-	B	h1
C 1092	CHIP CAP.	27pF	50V	CH	GRM1552C1H270JZ01D	K22178222		1-	B	a2
C 1093	CHIP CAP.	100pF	50V	CH	GRM1552C1H101JD01D	K22178236		1-	B	b2
C 1097	CHIP CAP.	0.001uF	50V	B	GRM155B11H102KA01D	K22178809		1-	B	c1
C 1098	CHIP CAP.	8pF	50V	CH	GRM1552C1H8R0BZ01D	K22178295		1-	B	b2
C 1099	CHIP CAP.	0.001uF	50V	B	GRM155B11H102KA01D	K22178809		1-	B	b2
C 1100	CHIP CAP.	2pF	50V	CK	GRM1554C1H2R0BZ01D	K22178289		1-	B	c2
C 1101	CHIP CAP.	7pF	50V	CH	GRM1552C1H7R0BZ01D	K22178294		1-	B	c2
C 1102	CHIP CAP.	0.001uF	50V	B	GRM155B11H102KA01D	K22178809		1-	B	c2
C 1103	CHIP CAP.	0.01uF	16V	B	GRM36B103K16PT	K22128804		1-	B	c2
C 1103	CHIP CAP.	0.01uF	25V	B	GRM155B11E103KA01D	K22148834		28-	B	c2
C 1104	CHIP CAP.	8pF	50V	CH	GRM1552C1H8R0BZ01D	K22178295		1-	B	c2
C 1106	CHIP CAP.	0.001uF	50V	B	GRM155B11H102KA01D	K22178809		1-	B	c2
C 1107	CHIP CAP.	0.001uF	50V	B	GRM155B11H102KA01D	K22178809		1-	B	c2
C 1108	CHIP CAP.	0.001uF	50V	B	GRM155B11H102KA01D	K22178809		1-	B	c2
C 1109	CHIP CAP.	1pF	50V	CK	GRM1554C1H1R0BZ01D	K22178287		1-	B	c2
C 1110	CHIP CAP.	1pF	50V	CK	GRM1554C1H1R0BZ01D	K22178287		1-	B	c2
C 1111	CHIP CAP.	0.5pF	50V	CK	GRM1554C1HR50BZ01D	K22178285		1-	B	c1
C 1112	CHIP CAP.	0.75pF	50V	CK	GRM1554C1HR75BZ01D	K22178286		1-	B	c1
C 1113	CHIP CAP.	10pF	50V	CH	GRM1552C1H100BZ01D	K22178297		1-	B	c1
C 1114	CHIP CAP.	47pF	50V	CH	GRM1552C1H470JZ01D	K22178228		1-	B	c1
C 1115	CHIP CAP.	47pF	50V	CH	GRM1552C1H470JZ01D	K22178228		1-	B	c1
C 1116	CHIP CAP.	0.5pF	50V	CK	GRM1554C1HR50BZ01D	K22178285		1-	B	c2
C 1117	CHIP CAP.	0.75pF	50V	CK	GRM1554C1HR75BZ01D	K22178286		1-	B	d1
C 1118	CHIP CAP.	4pF	50V	CH	GRM1552C1H4R0BZ01D	K22178291		1-	B	c1
C 1119	CHIP CAP.	47pF	50V	CH	GRM1552C1H470JZ01D	K22178228		1-	B	c1
C 1120	CHIP CAP.	0.5pF	50V	CK	GRM1554C1HR50BZ01D	K22178285		1-	B	d1
C 1121	CHIP CAP.	8pF	50V	CH	GRM1552C1H8R0BZ01D	K22178295		1-	B	d1
C 1122	CHIP CAP.	0.001uF	50V	B	GRM155B11H102KA01D	K22178809		1-	B	d1
C 1123	CHIP CAP.	0.001uF	50V	B	GRM155B11H102KA01D	K22178809		1-	B	d1
C 1124	CHIP CAP.	0.01uF	16V	B	GRM36B103K16PT	K22128804		1-	B	d1
C 1124	CHIP CAP.	0.01uF	25V	B	GRM155B11E103KA01D	K22148834		28-	B	d1
C 1125	CHIP CAP.	0.001uF	50V	B	GRM155B11H102KA01D	K22178809		1-	B	d1
C 1126	CHIP CAP.	56pF	50V	CH	GRM1552C1H560JD01D	K22178230		1-	B	d1
C 1128	CHIP CAP.	6pF	50V	CH	GRM1552C1H6R0BZ01D	K22178293		1-	B	e1
C 1129	CHIP CAP.	0.001uF	50V	B	GRM155B11H102KA01D	K22178809		1-	B	d1
C 1130	CHIP CAP.	22pF	50V	CH	GRM1552C1H220JZ01D	K22178220		1-	B	d1
C 1131	CHIP CAP.	0.001uF	50V	B	GRM155B11H102KA01D	K22178809		1-	A	C1
C 1132	CHIP CAP.	43pF	50V	CH	GRM1552C1H430JD01D	K22178227		1-	A	C1
C 1133	CHIP CAP.	0.001uF	50V	B	GRM155B11H102KA01D	K22178809		1-	B	e2
C 1134	CHIP TA.CAP.	22uF	6.3V		TEESVA0J226M8R	K78080047		1-	B	g2
C 1134	CHIP CAP.	10uF	6.3V	B	JMK316BJ106KL-T	K22081802		6-	B	g2
C 1135	CHIP CAP.	0.01uF	16V	B	GRM36B103K16PT	K22128804		1-	B	g3
C 1135	CHIP CAP.	0.01uF	25V	B	GRM155B11E103KA01D	K22148834		28-	B	g3
C 1136	CHIP CAP.	39pF	50V	CH	GRM1552C1H390JZ01D	K22178226		1-	B	g3
C 1137	CHIP CAP.	0.1uF	10V	B	GRM155B11A104KA01D	K22108802		1-	B	g3
C 1138	CHIP CAP.	0.1uF	10V	B	GRM155B11A104KA01D	K22108802		1-	B	g3
C 1139	CHIP CAP.	56pF	50V	CH	GRM1552C1H560JD01D	K22178230		1-	B	g2
C 1139	CHIP CAP.	56pF	50V	CH	GRM1552C1H560JD01D	K22178230		17-	B	g2
C 1140	CHIP CAP.	68pF	50V	CH	GRM1552C1H680JZ01D	K22178232		1-	B	g2
C 1140	CHIP CAP.	68pF	50V	CH	GRM1552C1H680JZ01D	K22178232		17-	B	g2
C 1141	CHIP CAP.	0.1uF	10V	B	GRM155B11A104KA01D	K22108802		1-	B	f2

MAIN Unit

Parts List

REF	DESCRIPTION	VALUE	V/W	TOL.	MFR'S DESIG	VXSTD P/N	VERS.	LOT	SIDE	LAY ADR
C 1142	CHIP CAP.	0.01uF	16V	B	GRM36B103K16PT	K22128804		1-	B	g3
C 1142	CHIP CAP.	0.01uF	25V	B	GRM155B11E103KA01D	K22148834		28-	B	g3
C 1143	CHIP CAP.	0.01uF	16V	B	GRM36B103K16PT	K22128804		1-	B	g3
C 1143	CHIP CAP.	0.01uF	25V	B	GRM155B11E103KA01D	K22148834		28-	B	g3
C 1144	CHIP CAP.	0.1uF	10V	B	GRM155B11A104KA01D	K22108802		1-	B	g3
C 1145	CHIP CAP.	470pF	50V	B	GRM155B11H471KA01D	K22178805		1-	B	g2
C 1146	CHIP CAP.	470pF	50V	B	GRM155B11H471KA01D	K22178805		1-	B	g2
C 1147	CHIP CAP.	220pF	50V	B	GRM155B11H221KA01D	K22178801		1-	B	f2
C 1148	CHIP CAP.	680pF	50V	B	GRM155B11H681KA01D	K22178807		1-	B	f2
C 1149	CHIP CAP.	0.001uF	50V	B	GRM155B11H102KA01D	K22178809		1-	B	g2
C 1150	CHIP CAP.	0.01uF	16V	B	GRM36B103K16PT	K22128804		1-	B	g2
C 1150	CHIP CAP.	0.01uF	25V	B	GRM155B11E103KA01D	K22148834		28-	B	g2
C 1151	CHIP CAP.	0.01uF	16V	B	GRM36B103K16PT	K22128804		1-	B	h3
C 1151	CHIP CAP.	0.01uF	25V	B	GRM155B11E103KA01D	K22148834		28-	B	h3
C 1152	CHIP CAP.	0.001uF	50V	B	GRM155B11H102KA01D	K22178809		1-	A	C2
C 1153	CHIP TA.CAP.	10uF	10V		TEESVA1A106M8R	K78100028		1-	A	C2
C 1154	CHIP TA.CAP.	10uF	10V		TEESVA1A106M8R	K78100028		1-	A	C2
C 1155	CHIP CAP.	1uF	6.3V	B	GRM188B10J105KA01D	K22084801		1-	A	F2
C 1156	CHIP CAP.	0.1uF	25V	B	GRM21BB11E104KA01L	K22140811		1-	A	F2
C 1157	CHIP CAP.	0.001uF	50V	B	GRM155B11H102KA01D	K22178809		1-	A	F3
C 1158	CHIP TA.CAP.	4.7uF	16V		TEESVA1C475M8R	K78120031		1-	A	G3
C 1158	CHIP TA.CAP.	4.7uF	16V		TEESVA21C475M8R	K78120080		26-	A	G3
C 1159	CHIP TA.CAP.	4.7uF	16V		TEESVA1C475M8R	K78120031		1-	A	F2
C 1159	CHIP TA.CAP.	4.7uF	16V		TEESVA21C475M8R	K78120080		26-	A	F2
C 1160	CHIP CAP.	0.1uF	10V	B	GRM155B11A104KA01D	K22108802		1-	B	f2
C 1161	CHIP CAP.	0.001uF	50V	B	GRM155B11H102KA01D	K22178809		1-	A	G2
C 1162	AL.ELECTRO.CAP.	100uF	16V		EEE1CA101WP	K48120012		1-	B	a3
C 1162	AL.ELECTRO.CAP.	100uF	16V		UWX1C101MCL1GB	K48120032		39-	B	a3
C 1163	CHIP TA.CAP.	10uF	10V		TEESVA1A106M8R	K78100028		1-	A	G3
C 1163	CHIP TA.CAP.	10uF	10V		TEESVA21A106M8R	K78100076		26-	A	G3
C 1164	CHIP CAP.	0.1uF	10V	B	GRM155B11A104KA01D	K22108802		1-	A	G3
C 1165	CHIP CAP.	0.001uF	50V	B	GRM155B11H102KA01D	K22178809		1-	A	G3
C 1166	CHIP CAP.	0.1uF	10V	B	GRM155B11A104KA01D	K22108802		1-	A	G2
C 1167	AL.ELECTRO.CAP.	100uF	10V		RVZ-10V101MF55U-R2	K48100008		1-	B	b2
C 1167	AL.ELECTRO.CAP.				UWX1C101MCL1GB	S8101395		36-	B	b2
C 1167	AL.ELECTRO.CAP.	100uF	16V		UWX1C101MCL1GB	K48120032		44-	B	b2
C 1168	CHIP CAP.	0.1uF	10V	B	GRM155B11A104KA01D	K22108802		1-	A	G2
C 1169	AL.ELECTRO.CAP.	100uF	10V		RVZ-10V101MF55U-R2	K48100008		1-	B	a3
C 1169	AL.ELECTRO.CAP.				UWX1C101MCL1GB	S8101395		36-	B	a3
C 1169	AL.ELECTRO.CAP.	100uF	16V		UWX1C101MCL1GB	K48120032		44-	B	a3
C 1170	CHIP CAP.	0.001uF	50V	B	GRM155B11H102KA01D	K22178809		1-	A	F2
C 1171	CHIP CAP.	0.001uF	50V	B	GRM155B11H102KA01D	K22178809		1-	A	F2
C 1172	CHIP CAP.	100pF	50V	CH	GRM1552C1H101JD01D	K22178236		1-	A	G2
C 1173	CHIP CAP.	100pF	50V	CH	GRM1552C1H101JD01D	K22178236		1-	A	G2
C 1174	CHIP CAP.	0.001uF	50V	B	GRM155B11H102KA01D	K22178809		1-	B	a2
C 1175	CHIP CAP.	0.0047uF	25V	B	GRM36B472K25PT	K22148830		1-	A	H3
C 1175	CHIP CAP.	0.0047uF	50V	B	GRM155B11H472KA01D	K22178838		28-	A	H3
C 1176	CHIP CAP.	0.0047uF	25V	B	GRM36B472K25PT	K22148830		1-	A	H3
C 1176	CHIP CAP.	0.0047uF	50V	B	GRM155B11H472KA01D	K22178838		28-	A	H3
C 1177	CHIP CAP.	0.001uF	50V	B	GRM155B11H102KA01D	K22178809		1-	B	b1
C 1178	CHIP CAP.	0.1uF	10V	B	GRM155B11A104KA01D	K22108802		1-	B	f4
C 1179	CHIP CAP.	0.1uF	10V	B	GRM155B11A104KA01D	K22108802		1-	B	f4
C 1180	CHIP CAP.	0.01uF	16V	B	GRM36B103K16PT	K22128804		1-	B	d3
C 1180	CHIP CAP.	0.01uF	25V	B	GRM155B11E103KA01D	K22148834		28-	B	d3
C 1181	CHIP CAP.	0.01uF	16V	B	GRM36B103K16PT	K22128804		1-	B	d3
C 1181	CHIP CAP.	0.01uF	25V	B	GRM155B11E103KA01D	K22148834		28-	B	d3
C 1182	CHIP CAP.	0.0022uF	50V	B	GRM155B11H222KA01D	K22178813		1-	B	d3
C 1183	CHIP CAP.	0.01uF	16V	B	GRM36B103K16PT	K22128804		1-	B	d3
C 1183	CHIP CAP.	0.01uF	25V	B	GRM155B11E103KA01D	K22148834		28-	B	d3
C 1184	CHIP CAP.	0.1uF	10V	B	GRM155B11A104KA01D	K22108802		1-	B	d3
C 1185	CHIP CAP.	0.1uF	10V	B	GRM155B11A104KA01D	K22108802		1-	B	d3
C 1186	CHIP TA.CAP.	22uF	6.3V		TEESVA0J226M8R	K78080047		1-	B	d3
C 1187	CHIP CAP.	0.001uF	50V	B	GRM155B11H102KA01D	K22178809		1-	B	g4
C 1188	CHIP CAP.	0.001uF	50V	B	GRM155B11H102KA01D	K22178809		1-	B	g4
C 1189	CHIP CAP.	0.001uF	50V	B	GRM155B11H102KA01D	K22178809		1-	B	g3
C 1190	CHIP CAP.	0.0068uF	25V	B	GRM155B11E682KA01D	K22148803		1-	B	g3
C 1191	CHIP CAP.	0.1uF	10V	B	GRM155B11A104KA01D	K22108802		1-	B	g3
C 1192	CHIP CAP.	0.1uF	10V	B	GRM155B11A104KA01D	K22108802		1-	B	g3
C 1193	CHIP CAP.	0.047uF	10V	B	GRM155B11A473KA01D	K22108801		1-	B	g3
C 1194	CHIP CAP.	0.01uF	16V	B	GRM36B103K16PT	K22128804		1-	A	G3
C 1194	CHIP CAP.	0.01uF	25V	B	GRM155B11E103KA01D	K22148834		28-	A	G3
C 1195	CHIP CAP.	0.001uF	50V	B	GRM155B11H102KA01D	K22178809		1-	A	E1
C 1196	CHIP CAP.	0.001uF	50V	B	GRM155B11H102KA01D	K22178809		1-	A	D1

MAIN Unit

Parts List

REF	DESCRIPTION	VALUE	V/W	TOL.	MFR'S DESIG	VXSTD P/N	VERS.	LOT	SIDE	LAY ADR
C 1197	CHIP CAP.	0.1uF	10V	B	GRM155B11A104KA01D	K22108802		1-	A	D1
C 1198	CHIP CAP.	0.001uF	50V	B	GRM155B11H102KA01D	K22178809		1-	A	D1
C 1199	CHIP CAP.	0.001uF	50V	B	GRM155B11H102KA01D	K22178809		1-	B	b4
C 1200	AL.ELECTRO.CAP.	47uF	16V		RV4-16V470MF46-RR2	K48120019		1-	B	b3
C 1200	AL.ELECTRO.CAP.	47uF	16V		UZS1C470MCL1GB	K48120031		30-	B	b3
C 1201	CHIP CAP.	0.001uF	50V	B	GRM155B11H102KA01D	K22178809		1-	B	b4
C 1202	CHIP TA.CAP.	150uF	4V		TEESVC0G157M12R	K78060034		1-	B	a4
C 1203	CHIP CAP.	0.1uF	25V	B	GRM21BB11E104KA01L	K22140811		1-	A	G3
C 1204	CHIP CAP.	0.22uF	10V	B	GRM188B11A224KA01D	K22104801		1-	A	H3
C 1205	CHIP TA.CAP.	22uF	6.3V		TEESVA0J226M8R	K78080047		1-	A	G2
C 1205	CHIP TA.CAP.	22uF	6.3V		TEESVA20J226M8R	K78080088		26-	A	G2
C 1206	CHIP CAP.	0.001uF	50V	B	GRM155B11H102KA01D	K22178809		1-	A	G2
C 1207	CHIP CAP.	0.022uF	16V	B	GRM155B11C223KA01D	K22128806		1-	B	d2
C 1208	CHIP CAP.	1uF	6.3V	B	GRM188B10J105KA01D	K22084801		1-	B	d2
C 1209	CHIP CAP.	0.01uF	16V	B	GRM36B103K16PT	K22128804		1-	B	d2
C 1209	CHIP CAP.	0.01uF	25V	B	GRM155B11E103KA01D	K22148834		28-	B	d2
C 1210	CHIP CAP.	330pF	50V	B	GRM155B11H331KA01D	K22178803		1-	B	c2
C 1211	CHIP TA.CAP.	4.7uF	16V		TEESVA1C475M8R	K78120031		1-	B	c2
C 1212	CHIP CAP.	0.022uF	16V	B	GRM155B11C223KA01D	K22128806		1-	B	c2
C 1213	CHIP CAP.	0.01uF	16V	B	GRM36B103K16PT	K22128804		1-	B	c2
C 1213	CHIP CAP.	0.01uF	25V	B	GRM155B11E103KA01D	K22148834		28-	B	c2
C 1214	CHIP CAP.	0.0047uF	25V	B	GRM36B472K25PT	K22148830		1-	B	c2
C 1214	CHIP CAP.	0.0047uF	50V	B	GRM155B11H472KA01D	K22178838		28-	B	c2
C 1215	CHIP CAP.	680pF	50V	B	GRM155B11H681KA01D	K22178807		1-	B	c2
C 1216	CHIP CAP.	470pF	50V	B	GRM155B11H471KA01D	K22178805		1-	B	c2
C 1217	CHIP CAP.	0.022uF	16V	B	GRM155B11C223KA01D	K22128806		1-	B	c3
C 1218	CHIP CAP.	0.0068uF	25V	B	GRM155B11E682KA01D	K22148803		1-	B	c3
C 1219	CHIP CAP.	330pF	50V	B	GRM155B11H331KA01D	K22178803		1-	B	c3
C 1220	CHIP CAP.	680pF	50V	B	GRM155B11H681KA01D	K22178807		1-	B	c3
C 1221	CHIP CAP.	0.0047uF	25V	B	GRM36B472K25PT	K22148830		1-	B	c3
C 1221	CHIP CAP.	0.0047uF	50V	B	GRM155B11H472KA01D	K22178838		28-	B	c3
C 1222	CHIP CAP.	0.22uF	10V	B	GRM188B11A224KA01D	K22104801		1-	B	c3
C 1223	CHIP CAP.	1uF	6.3V	B	GRM188B10J105KA01D	K22084801		1-	B	d2
C 1224	CHIP CAP.	0.0068uF	25V	B	GRM155B11E682KA01D	K22148803		1-	B	c2
C 1225	CHIP CAP.	0.0068uF	25V	B	GRM155B11E682KA01D	K22148803		1-	B	d2
C 1226	CHIP CAP.	100pF	50V	CH	GRM1552C1H101JD01D	K22178236		1-	B	d2
C 1227	CHIP CAP.	0.1uF	10V	B	GRM155B11A104KA01D	K22108802		1-	B	d3
C 1228	CHIP CAP.	0.001uF	50V	B	GRM155B11H102KA01D	K22178809		1-	B	c1
C 1229	CHIP CAP.	0.001uF	50V	B	GRM155B11H102KA01D	K22178809		1-	A	E3
C 1230	CHIP CAP.	0.001uF	50V	B	GRM155B11H102KA01D	K22178809		1-	B	c4
C 1231	CHIP CAP.	0.001uF	50V	B	GRM155B11H102KA01D	K22178809		1-	B	c4
C 1232	CHIP TA.CAP.	4.7uF	16V		TEESVA1C475M8R	K78120031		1-	A	F3
C 1233	CHIP CAP.	0.01uF	16V	B	GRM36B103K16PT	K22128804		1-	B	c4
C 1233	CHIP CAP.	0.01uF	25V	B	GRM155B11E103KA01D	K22148834		28-	B	c4
C 1234	CHIP CAP.	0.001uF	50V	B	GRM155B11H102KA01D	K22178809		1-	B	c4
C 1235	CHIP CAP.	0.022uF	16V	B	GRM155B11C223KA01D	K22128806		1-	B	c3
C 1236	CHIP CAP.	0.022uF	16V	B	GRM155B11C223KA01D	K22128806		1-	B	c3
C 1237	CHIP CAP.	470pF	50V	B	GRM155B11H471KA01D	K22178805		1-	B	c3
C 1238	CHIP CAP.	0.001uF	50V	B	GRM155B11H102KA01D	K22178809		1-	A	F3
C 1239	CHIP CAP.	0.001uF	50V	B	GRM155B11H102KA01D	K22178809		1-	A	F1
C 1240	CHIP CAP.	0.001uF	50V	B	GRM155B11H102KA01D	K22178809		1-	B	b4
C 1241	CHIP CAP.	0.001uF	50V	B	GRM155B11H102KA01D	K22178809		1-	A	A4
C 1242	CHIP CAP.	0.001uF	50V	B	GRM155B11H102KA01D	K22178809		1-	B	c3
C 1243	CHIP CAP.	0.001uF	50V	B	GRM155B11H102KA01D	K22178809		1-	B	d3
C 1244	CHIP CAP.	0.1uF	10V	B	GRM155B11A104KA01D	K22108802		1-	B	c3
C 1245	CHIP CAP.	0.0047uF	25V	B	GRM36B472K25PT	K22148830		1-	B	b3
C 1245	CHIP CAP.	0.0047uF	50V	B	GRM155B11H472KA01D	K22178838		28-	B	b3
C 1246	CHIP CAP.	5pF	50V	CH	GRM1552C1H5R0BZ01D	K22178292		1-	B	b3
C 1247	CHIP TA.CAP.	10uF	10V		TEESVA1A106M8R	K78100028		1-	B	b2
C 1248	CHIP CAP.	0.01uF	16V	B	GRM36B103K16PT	K22128804		1-	B	b3
C 1248	CHIP CAP.	0.01uF	25V	B	GRM155B11E103KA01D	K22148834		28-	B	b3
C 1249	CHIP CAP.	0.1uF	10V	B	GRM155B11A104KA01D	K22108802		1-	B	c3
C 1250	CHIP CAP.	0.001uF	50V	B	GRM155B11H102KA01D	K22178809		1-	B	c3
C 1251	CHIP CAP.	0.001uF	50V	B	GRM155B11H102KA01D	K22178809		1-	B	c3
C 1252	CHIP CAP.	27pF	50V	CH	GRM1552C1H270JZ01D	K22178222		1-	B	c3
C 1253	CHIP CAP.	470pF	50V	B	GRM155B11H471KA01D	K22178805		1-	B	c3
C 1255	CHIP CAP.	1uF	6.3V	B	GRM188B10J105KA01D	K22084801		1-	B	c3
C 1256	CHIP CAP.	0.1uF	10V	B	GRM155B11A104KA01D	K22108802		1-	A	E2
C 1257	CHIP CAP.	0.0047uF	25V	B	GRM36B472K25PT	K22148830		1-	A	F2
C 1257	CHIP CAP.	0.0047uF	50V	B	GRM155B11H472KA01D	K22178838		28-	A	F2
C 1258	CHIP CAP.	0.01uF	16V	B	GRM36B103K16PT	K22128804		1-	A	D2
C 1258	CHIP CAP.	0.01uF	25V	B	GRM155B11E103KA01D	K22148834		28-	A	D2
C 1259	CHIP CAP.	0.0047uF	25V	B	GRM36B472K25PT	K22148830		1-	A	D3

MAIN Unit

Parts List

REF	DESCRIPTION	VALUE	V/W	TOL.	MFR'S DESIG	VXSTD P/N	VERS.	LOT	SIDE	LAY ADR
C 1259	CHIP CAP.	0.0047uF	50V	B	GRM155B11H472KA01D	K22178838		28-	A	D3
C 1260	CHIP CAP.	2pF	50V	CK	GRM1554C1H2R0BZ01D	K22178289		1-	B	d2
C 1261	CHIP CAP.	22pF	50V	CH	GRM1552C1H220JZ01D	K22178220		1-	B	d2
C 1262	CHIP CAP.	18pF	50V	CH	GRM1552C1H180JZ01D	K22178218		1-	B	d2
C 1263	CHIP CAP.	0.1uF	10V	B	GRM155B11A104KA01D	K22108802		1-	A	E3
C 1264	CHIP CAP.	0.1uF	10V	B	GRM155B11A104KA01D	K22108802		1-	A	E3
C 1265	CHIP CAP.	0.1uF	10V	B	GRM155B11A104KA01D	K22108802		1-	A	E3
C 1266	CHIP CAP.	0.1uF	10V	B	GRM155B11A104KA01D	K22108802		1-	A	E2
C 1267	CHIP TA.CAP.	47uF	4V		SK7-0G476M-RA	K78060048		1-	B	d2
C 1268	CHIP CAP.	0.001uF	50V	B	GRM155B11H102KA01D	K22178809		1-	A	D3
C 1269	CHIP CAP.	0.1uF	10V	B	GRM155B11A104KA01D	K22108802		1-	A	D3
C 1270	CHIP CAP.	0.001uF	50V	B	GRM155B11H102KA01D	K22178809		1-	A	D1
C 1271	CHIP CAP.	0.001uF	50V	B	GRM155B11H102KA01D	K22178809		1-	A	D1
C 1272	CHIP CAP.	0.001uF	50V	B	GRM155B11H102KA01D	K22178809		1-	A	D1
C 1273	CHIP CAP.	0.001uF	50V	B	GRM155B11H102KA01D	K22178809		1-	A	F4
C 1274	CHIP CAP.	0.001uF	50V	B	GRM155B11H102KA01D	K22178809		1-	A	D4
C 1275	CHIP TA.CAP.	22uF	6.3V		TEESVA0J226M8R	K78080047		1-	B	b3
C 1276	CHIP TA.CAP.	10uF	10V		TEESVA1A106M8R	K78100028		1-	B	g3
C 1277	CHIP CAP.	0.0033uF	50V	B	GRM155B11H332KA01D	K22178815		1-	B	g3
C 1278	CHIP CAP.	0.1uF	10V	B	GRM155B11A104KA01D	K22108802		1-	A	C3
C 1279	CHIP CAP.	0.1uF	10V	B	GRM155B11A104KA01D	K22108802		1-	B	g2
C 1280	CHIP CAP.	0.1uF	10V	B	GRM155B11A104KA01D	K22108802		1-	B	d4
C 1281	CHIP CAP.	0.1uF	10V	B	GRM155B11A104KA01D	K22108802		1-	B	e2
C 1282	CHIP CAP.	22pF	50V	CH	GRM1552C1H220JZ01D	K22178220		9-	A	F1
C 1283	CHIP CAP.	12pF	50V	CH	GRM1552C1H120JZ01D	K22178214		1-8	A	F1
C 1284	CHIP CAP.	0.5pF	50V	CK	GRM1554C1HR50BZ01D	K22178285		1-	B	f1
C 1285	CHIP CAP.	0.1uF	10V	B	GRM155B11A104KA01D	K22108802		1-	B	d4
CD1001	CERAMIC DISC				JTBC450C7	H7901500		1-	B	g2
CD1001	CERAMIC DISC				JTBM450CX7	H7901520		17-	B	g2
CF1001	CERAMIC FILTER				LTWC450G	H3900562		1-3	B	g2
CF1002	CERAMIC FILTER				LTWC450F	H3900563		1-	B	g3
D 1002	DIODE				1SS321(TE85R.F)	G2070076		1-	A	G1
D 1003	DIODE				RLS135 TE-11	G2070128		1-	B	b1
D 1004	DIODE				RLS135 TE-11	G2070128		1-	B	a1
D 1007	DIODE				1SS400 TE61	G2070634		1-	B	e1
D 1008	DIODE				1SS400 TE61	G2070634		1-	B	e1
D 1009	DIODE				HVC365 TRF-E	G2070902		1-	B	f1
D 1010	DIODE				HVC365 TRF-E	G2070902		1-	B	f1
D 1011	DIODE				HSC277TRF-E	G2070584		1-	B	f1
D 1012	DIODE				DA221 TL	G2070178		1-	B	g1
D 1013	DIODE				1SS400 TE61	G2070634		1-	B	h1
D 1014	DIODE				HVC350B-TRF-E	G2070596		1-	B	h1
D 1015	DIODE				HVC350B-TRF-E	G2070596		1-	B	g1
D 1016	DIODE				HVC375B-TRF-E	G2070856		1-	B	b2
D 1017	DIODE				HVC350B-TRF-E	G2070596		1-	B	c1
D 1018	DIODE				HVC350B-TRF-E	G2070596		1-	B	c1
D 1019	DIODE				HVC350B-TRF-E	G2070596		1-	B	c1
D 1020	DIODE				1SS400 TE61	G2070634		1-	A	C1
D 1021	DIODE				DAN222 TL	G2070174		1-3	B	g3
D 1022	DIODE				DAN222 TL	G2070174		1-3	B	g2
D 1023	DIODE				1SS400 TE61	G2070634		1-	A	C2
D 1024	DIODE				DAN222 TL	G2070174		1-	A	F2
D 1025	DIODE				DA221 TL	G2070178		1-	A	G2
D 1026	DIODE				1SS400 TE61	G2070634		1-	A	D1
D 1027	DIODE				UDZS TE-17 9.1B	G2070868		1-	A	E1
D 1028	DIODE				1SS400 TE61	G2070634		1-	A	D1
D 1029	DIODE				DAN222 TL	G2070174		1-	B	b4
D 1030	DIODE				DA221 TL	G2070178		1-	B	c3
D 1031	DIODE				EDZ TE-61 5.1B	G2070998		1-	B	c3
D 1032	DIODE				M1FM3-5063	G2070804		1-	A	F3
D 1032	DIODE				M1FM3-6063	G2071090		44-	A	F3
D 1033	DIODE				1SS400 TE61	G2070634		1-	A	F4
D 1034	DIODE				RB551V-30 TE-17	G2070892		1-	A	B4
D 1035	DIODE				HZU2.0BTRF	G2070844		1-	A	F4
D 1036	DIODE				1SS400 TE61	G2070634		1-	A	C3
D 1037	DIODE				1SS400 TE61	G2070634		1-	A	D3
D 1038	DIODE				1SS400 TE61	G2070634		1-	A	C4
D 1039	DIODE				1SS400 TE61	G2070634		1-	A	C4
D 1040	DIODE				1SS400 TE61	G2070634		1-	A	C4
D 1041	DIODE				1SS400 TE61	G2070634		1-	A	C4
D 1042	DIODE				1SS400 TE61	G2070634		1-	A	D3
D 1043	DIODE				1SS400 TE61	G2070634		1-	A	D3
D 1044	LED				CL-165HR/YG-D-T	G2070860		1-	A	G4

MAIN Unit

Parts List

REF	DESCRIPTION	VALUE	V/W	TOL.	MFR'S DESIG	VXSTD P/N	VERS.	LOT	SIDE	LAY ADR
D 1045	LED				19-215UYOC/S530-A2/TR8	G2070884		1-	A	A1
D 1045	LED				19-213/S2C-AN1P2B/3T	G2071096		5-	A	A1
D 1046	LED				19-215UYOC/S530-A2/TR8	G2070884		1-	A	B1
D 1046	LED				19-213/S2C-AN1P2B/3T	G2071096		5-	A	B1
D 1047	LED				19-215UYOC/S530-A2/TR8	G2070884		1-	A	A3
D 1047	LED				19-213/S2C-AN1P2B/3T	G2071096		5-	A	A3
D 1048	LED				19-215UYOC/S530-A2/TR8	G2070884		1-	A	B3
D 1048	LED				19-213/S2C-AN1P2B/3T	G2071096		5-	A	B3
D 1049	LED				19-215UYOC/S530-A2/TR8	G2070884		1-	A	D1
D 1049	LED				19-213/S2C-AN1P2B/3T	G2071096		5-	A	D1
D 1050	LED				19-215UYOC/S530-A2/TR8	G2070884		1-	A	E1
D 1050	LED				19-213/S2C-AN1P2B/3T	G2071096		5-	A	E1
D 1051	LED				19-215UYOC/S530-A2/TR8	G2070884		1-	A	D1
D 1051	LED				19-213/S2C-AN1P2B/3T	G2071096		5-	A	D1
DS1001	LCD				20667TF-F	G6090166		1-	A	D2
FB1001	FERRITE BEADS				BLM15AG121SN1D	L1690843		1-	A	H2
FB1002	FERRITE BEADS				BLM15AG121SN1D	L1690843		1-	B	b2
FB1003	FERRITE BEADS				BLM15AG121SN1D	L1690843		1-	A	G2
FB1004	FERRITE BEADS				BLM15AG121SN1D	L1690843		1-	A	G2
FB1005	FERRITE BEADS				BLM15AG121SN1D	L1690843		1-	A	H2
FB1006	FERRITE BEADS				BLM15AG121SN1D	L1690843		1-	B	a2
HS1001	HEATSINK PLATE					RA0653300		1-	B	c1
HS1001	HEATSINK PLATE					RA065330A		7-	B	c1
J 1001	SPRINGCONNECTOR					R0152490		1-	B	a1
J 1002	CONNECTOR				AXK6F14345YJ	P0091406		1-	B	f3
J 1003	CONNECTOR				AXK6F10345YP	P0091378		1-	B	d3
J 1004	CONNECTOR				HEC3604-010110	P0091263		1-	B	d4
J 1004	CONNECTOR				DC-016PA9T	P0091445		60-	B	d4
J 1005	CONTACT				OG-503040	S5000243		1-	A	F2
J 1006	CONTACT				OG-503040	S5000243		1-	A	F2
J 1007	CONNECTOR				HSJ1594-010055	P1090896		1-	B	a2
L 1001	COIL				E2 0.35-1.6-7T-L	L0022390		1-	B	a1
L 1002	COIL				E2 0.3-1.7-7T-R	L0022372		1-	B	a1
L 1003	COIL				E2 0.3-1.7-7T-R	L0022372		1-	B	b1
L 1004	M.RFC	1uH			ELJ-ND1R0JF	L1690977		1-	A	F1
L 1005	COIL				E2 0.35-1.6-4T-L	L0022456		1-	B	b1
L 1006	COIL				E2 0.45-1.4-4T-L	L0022391		1-	B	b1
L 1007	COIL				E2 0.45-1.4-4T-L	L0022391		1-	B	c1
L 1008	COIL				E2 0.25-1.9-8.5T-L	L0022611		1-	B	b1
L 1009	COIL				E2 0.28-1.0-4.5T-R	L0022395		1-	B	c1
L 1010	COIL				E2 0.28-1.0-8TR	L0022423		1-	B	d1
L 1011	M.RFC	0.047uH		2%	C1608CB-47NG-RF	L1691040		1-	B	d1
L 1012	M.RFC	0.056uH		2%	C1608CB-56NG-RF	L1691041		1-	B	e1
L 1013	M.RFC	0.15uH			LK1608 R15K-T	L1690409		1-	B	f1
L 1014	M.RFC	0.056uH		2%	C1608CB-56NG-RF	L1691041		1-	B	f1
L 1015	M.RFC	0.039uH		2%	C1608CB-39NG-RF	L1691039		1-	B	f1
L 1016	M.RFC	0.0047uH			TFL0510-4N7	L1690807		1-	B	f1
L 1017	M.RFC	4.7uH			LK1608 4R7K-T	L1690688		1-	B	f1
L 1018	COIL				E2 0.25-1.9-5.5T-R	L0022610		1-	B	a2
L 1019	M.RFC	0.082uH		2%	C1608CB-82NG-RF	L1691044		1-	B	b2
L 1021	M.RFC	0.082uH		2%	C1608CB-82NG-RF	L1691044		1-	B	b2
L 1022	M.RFC	0.22uH		2%	C1608CB-R22G-RF	L1691103		1-	B	c2
L 1023	M.RFC	1uH			LK1608 1R0K-T	L1690687		1-	B	c2
L 1024	M.RFC	0.082uH		2%	C1608CB-82NG-RF	L1691044		1-	B	c2
L 1025	M.RFC	0.082uH		2%	C1608CB-82NG-RF	L1691044		1-	B	c2
L 1026	M.RFC	0.082uH		2%	C1608CB-82NG-RF	L1691044		1-	B	d1
L 1027	M.RFC	1uH			ELJ-ND1R0JF	L1690977		1-	B	d1
L 1028	M.RFC	0.047uH			TFL0816-47	L1690499		1-	B	d1
L 1029	M.RFC	1uH			LK1608 1R0K-T	L1690687		1-	A	C1
L 1030	M.RFC	1uH			LK1608 1R0K-T	L1690687		1-	B	f2
L 1031	M.RFC	0.039uH			TFL0510-39N	L1690818		1-	B	f2
L 1032	M.RFC	100uH			LLM3225-101J	L1691145		1-	B	d2
L 1033	M.RFC	1uH			LK1608 1R0K-T	L1690687		1-	B	e2
MC1001	MIC.ELEMENT				EM-100PT	M3290029		1-	A	F3
MC1001	MIC.ELEMENT				PF0-1055P	M3290045		39-	A	F3
Q 1001	IC				HD64F2266TF13V			1-	A	D2
Q 1002	IC				BR24L64F-WE2	G1093876		1-	A	D3
Q 1003	IC				MB15A01PFV1-G-BND-EFE1	G1092545		1-	B	g1
Q 1004	IC				NJM2591V-TE1	G1094024		1-	B	g3
Q 1005	IC				BU2090FS-E2	G1092187		1-	B	e2
Q 1006	IC				BD4845FVE-TR	G1093784		1-	A	D1
Q 1007	IC				NJU7231F33-TE1	G1094202		1-	B	a4
Q 1008	IC				TDA2822D013TR	G1091542		1-	A	G3

MAIN Unit

Parts List

REF	DESCRIPTION	VALUE	V/W	TOL.	MFR'S DESIG	VXSTD P/N	VERS.	LOT	SIDE	LAY ADR
Q 1008	IC				TDA2822L-S08-R	G1094497		26-	A	G3
Q 1009	FET				2SK3476(TE12L.Q)	G3834768		1-	A	F1
Q 1010	FET				2SK3074(TE12L.F)	G3830748		1-	B	d1
Q 1011	TRANSISTOR				2SC5005-T1	G3350058		1-	B	d1
Q 1012	TRANSISTOR				2SC5005-T1	G3350058		1-	B	e1
Q 1013	TRANSISTOR				2SC5005-T1	G3350058		1-	B	f1
Q 1014	TRANSISTOR				2SC5005-T1	G3350058		1-	B	f1
Q 1015	TRANSISTOR				DTC144EE TL	G3070075		1-	B	f2
Q 1015	TRANSISTOR				KRC404E-RTK/P	G3070355		10-	B	f2
Q 1016	TRANSISTOR				DTC144EE TL	G3070075		1-	B	g1
Q 1016	TRANSISTOR				KRC404E-RTK/P	G3070355		10-	B	g1
Q 1017	TRANSISTOR				2SC5005-T1	G3350058		1-	B	f1
Q 1018	TRANSISTOR				2SA1774 TL R	G3117748R		1-	B	f2
Q 1018	TRANSISTOR				KTA2014E-GR-RTK/P	G3070353		10-	B	f2
Q 1019	IC				LM2904PWR	G1094010		1-	A	G1
Q 1020	TRANSISTOR				DTC144EE TL	G3070075		1-	A	F1
Q 1020	TRANSISTOR				KRC404E-RTK/P	G3070355		10-	A	F1
Q 1021	TRANSISTOR				DTC144EE TL	G3070075		1-	A	F1
Q 1021	TRANSISTOR				KRC404E-RTK/P	G3070355		10-	A	F1
Q 1022	FET				3SK296ZQ-TL-E	G4802968		1-	B	c2
Q 1023	FET				3SK296ZQ-TL-E	G4802968		1-	B	d1
Q 1024	TRANSISTOR				2SC4915-O(TE85L.F)	G3349158O		1-	A	C1
Q 1025	TRANSISTOR				DTC144EE TL	G3070075		1-	B	f2
Q 1025	TRANSISTOR				KRC404E-RTK/P	G3070355		10-	B	f2
Q 1026	TRANSISTOR				DTC144EE TL	G3070075		1-	B	e2
Q 1026	TRANSISTOR				KRC404E-RTK/P	G3070355		10-	B	e2
Q 1027	TRANSISTOR				DTA144EE TL	G3070074		1-	B	g2
Q 1027	TRANSISTOR				KRA304E-RTK/P	G3070354		10-	B	g2
Q 1028	TRANSISTOR				2SC4617 TL R	G3346178R		1-	B	h2
Q 1028	TRANSISTOR				KTC4075E-GR-RTK/P	G3070356		10-	B	h2
Q 1029	TRANSISTOR				DTC144EE TL	G3070075		1-	A	G2
Q 1029	TRANSISTOR				KRC404E-RTK/P	G3070355		10-	A	G2
Q 1030	TRANSISTOR				2SA1774 TL R	G3117748R		1-	A	G2
Q 1030	TRANSISTOR				KTA2014E-GR-RTK/P	G3070353		10-	A	G2
Q 1031	TRANSISTOR				2SA1774 TL R	G3117748R		1-	A	F2
Q 1031	TRANSISTOR				KTA2014E-GR-RTK/P	G3070353		10-	A	F2
Q 1032	TRANSISTOR				2SA1774 TL R	G3117748R		1-	A	F2
Q 1032	TRANSISTOR				KTA2014E-GR-RTK/P	G3070353		10-	A	F2
Q 1033	TRANSISTOR				DTA144EE TL	G3070074		1-	A	C2
Q 1033	TRANSISTOR				KRA304E-RTK/P	G3070354		10-	A	C2
Q 1034	TRANSISTOR				2SA1774 TL R	G3117748R		1-	A	C2
Q 1034	TRANSISTOR				KTA2014E-GR-RTK/P	G3070353		10-	A	C2
Q 1035	TRANSISTOR				2SC4617 TL R	G3346178R		1-	A	C2
Q 1035	TRANSISTOR				KTC4075E-GR-RTK/P	G3070356		10-	A	C2
Q 1036	TRANSISTOR				2SA1774 TL R	G3117748R		1-	B	f2
Q 1036	TRANSISTOR				KTA2014E-GR-RTK/P	G3070353		10-	B	f2
Q 1037	TRANSISTOR				2SB1201S-TL	G3070195		1-	A	E2
Q 1038	TRANSISTOR				2SC4617 TL R	G3346178R		1-	A	F2
Q 1038	TRANSISTOR				KTC4075E-GR-RTK/P	G3070356		10-	A	F2
Q 1039	TRANSISTOR				2SC4617 TL R	G3346178R		1-	A	F2
Q 1039	TRANSISTOR				KTC4075E-GR-RTK/P	G3070356		10-	A	F2
Q 1040	TRANSISTOR				2SA1774 TL R	G3117748R		1-	A	F2
Q 1040	TRANSISTOR				KTA2014E-GR-RTK/P	G3070353		10-	A	F2
Q 1041	TRANSISTOR				FMRTL718TA	G3070335		1-	A	G2
Q 1042	TRANSISTOR				2SC4617 TL R	G3346178R		1-	A	F2
Q 1042	TRANSISTOR				KTC4075E-GR-RTK/P	G3070356		10-	A	F2
Q 1043	TRANSISTOR				DTA144EE TL	G3070074		1-	A	G2
Q 1043	TRANSISTOR				KRA304E-RTK/P	G3070354		10-	A	G2
Q 1044	TRANSISTOR				DTC144EE TL	G3070075		1-	A	G2
Q 1044	TRANSISTOR				KRC404E-RTK/P	G3070355		10-	A	G2
Q 1045	TRANSISTOR				DTC144EE TL	G3070075		1-	A	G3
Q 1045	TRANSISTOR				KRC404E-RTK/P	G3070355		10-	A	G3
Q 1046	IC				LM2902PWR	G1094009		1-	B	c2
Q 1047	TRANSISTOR				DTC144EE TL	G3070075		1-	B	c2
Q 1047	TRANSISTOR				KRC404E-RTK/P	G3070355		10-	B	c2
Q 1048	TRANSISTOR				DTC144EE TL	G3070075		1-	B	c2
Q 1048	TRANSISTOR				KRC404E-RTK/P	G3070355		10-	B	c2
Q 1049	TRANSISTOR				DTC144EE TL	G3070075		1-	B	c2
Q 1049	TRANSISTOR				KRC404E-RTK/P	G3070355		10-	B	c2
Q 1050	IC				LM2904PWR	G1094010		1-	B	d2
Q 1051	TRANSISTOR				DTC144EE TL	G3070075		1-	B	g4
Q 1051	TRANSISTOR				KRC404E-RTK/P	G3070355		10-	B	g4
Q 1052	TRANSISTOR				2SC4617 TL R	G3346178R		1-	B	f4

MAIN Unit

Parts List

REF	DESCRIPTION	VALUE	V/W	TOL.	MFR'S DESIG	VXSTD P/N	VERS.	LOT	SIDE	LAY ADR
Q 1052	TRANSISTOR				KTC4075E-GR-RTK/P	G3070356		10-	B	f4
Q 1054	TRANSISTOR				DTA144EE TL	G3070074		1-	B	d3
Q 1054	TRANSISTOR				KRA304E-RTK/P	G3070354		10-	B	d3
Q 1055	TRANSISTOR				2SC4617 TL R	G3346178R		1-	B	d4
Q 1055	TRANSISTOR				KTC4075E-GR-RTK/P	G3070356		10-	B	d4
Q 1056	FET				2SJ364-R(TX)	G3703648R		1-	B	f4
Q 1056	FET				2SJ364-Q(TX)	G3703648Q		8-	B	f4
Q 1057	TRANSISTOR				DTC144EE TL	G3070075		1-	A	E2
Q 1057	TRANSISTOR				KRC404E-RTK/P	G3070355		10-	A	E2
Q 1058	TRANSISTOR				DTA144EE TL	G3070074		1-	A	E3
Q 1058	TRANSISTOR				KRA304E-RTK/P	G3070354		10-	A	E3
Q 1059	TRANSISTOR				2SA1774 TL R	G3117748R		1-	A	F3
Q 1059	TRANSISTOR				KTA2014E-GR-RTK/P	G3070353		10-	A	F3
Q 1060	TRANSISTOR				2SC4617 TL R	G3346178R		1-	B	c4
Q 1060	TRANSISTOR				KTC4075E-GR-RTK/P	G3070356		10-	B	c4
Q 1061	TRANSISTOR				2SC4617 TL R	G3346178R		1-	A	D1
Q 1061	TRANSISTOR				KTC4075E-GR-RTK/P	G3070356		10-	A	D1
Q 1062	TRANSISTOR				2SC4617 TL R	G3346178R		1-	A	D1
Q 1062	TRANSISTOR				KTC4075E-GR-RTK/P	G3070356		10-	A	D1
Q 1063	TRANSISTOR				2SB1132 T100 R	G3211327R		1-	A	G3
Q 1064	TRANSISTOR				2SC4617 TL R	G3346178R		1-	A	H3
Q 1064	TRANSISTOR				KTC4075E-GR-RTK/P	G3070356		10-	A	H3
Q 1065	TRANSISTOR				2SC4617 TL R	G3346178R		1-	A	H3
Q 1065	TRANSISTOR				KTC4075E-GR-RTK/P	G3070356		10-	A	H3
Q 1066	TRANSISTOR				2SC4617 TL R	G3346178R		1-	B	d2
Q 1066	TRANSISTOR				KTC4075E-GR-RTK/P	G3070356		10-	B	d2
Q 1067	TRANSISTOR				2SD1664 T100 Q	G3416647Q		1-	A	G4
Q 1068	TRANSISTOR				DTC144EE TL	G3070075		1-	A	H4
Q 1068	TRANSISTOR				KRC404E-RTK/P	G3070355		10-	A	H4
Q 1069	TRANSISTOR				2SC4617 TL R	G3346178R		1-	A	G4
Q 1069	TRANSISTOR				KTC4075E-GR-RTK/P	G3070356		10-	A	G4
Q 1070	TRANSISTOR				DTC144EE TL	G3070075		1-	B	c3
Q 1070	TRANSISTOR				KRC404E-RTK/P	G3070355		10-	B	c3
Q 1071	TRANSISTOR				DTA144EE TL	G3070074		1-	A	E3
Q 1071	TRANSISTOR				KRA304E-RTK/P	G3070354		10-	A	E3
Q 1072	TRANSISTOR				2SC4617 TL R	G3346178R		1-	B	b3
Q 1072	TRANSISTOR				KTC4075E-GR-RTK/P	G3070356		10-	B	b3
Q 1073	TRANSISTOR				2SC4617 TL R	G3346178R		1-	B	b3
Q 1073	TRANSISTOR				KTC4075E-GR-RTK/P	G3070356		10-	B	b3
Q 1074	IC				LM2902PWR	G1094009		1-	B	c3
Q 1075	TRANSISTOR				DTC144EE TL	G3070075		1-	B	c2
Q 1075	TRANSISTOR				KRC404E-RTK/P	G3070355		10-	B	c2
Q 1076	TRANSISTOR				2SC4617 TL R	G3346178R		1-	A	G4
Q 1076	TRANSISTOR				KTC4075E-GR-RTK/P	G3070356		10-	A	G4
Q 1077	TRANSISTOR				2SC4617 TL R	G3346178R		1-	A	G4
Q 1077	TRANSISTOR				KTC4075E-GR-RTK/P	G3070356		10-	A	G4
Q 1078	TRANSISTOR				2SB1132 T100 R	G3211327R		1-	A	F3
Q 1079	TRANSISTOR				2SC4617 TL R	G3346178R		1-	A	F3
Q 1079	TRANSISTOR				KTC4075E-GR-RTK/P	G3070356		10-	A	F3
Q 1080	IC				XC6202P332PR	G1094186		1-	B	b3
Q 1081	TRANSISTOR				2SC4617 TL R	G3346178R		1-	B	f4
Q 1081	TRANSISTOR				KTC4075E-GR-RTK/P	G3070356		10-	B	f4
Q 1082	TRANSISTOR				2SC4617 TL R	G3346178R		1-	B	g3
Q 1082	TRANSISTOR				KTC4075E-GR-RTK/P	G3070356		10-	B	g3
Q 1083	IC				LM2904PWR	G1094010		1-	B	d3
Q 1084	TRANSISTOR				DTA144EE TL	G3070074		1-	B	d3
Q 1084	TRANSISTOR				KRA304E-RTK/P	G3070354		10-	B	d3
R 1001	CHIPRES.	10k	1/16W	5%	RMC1/16S 103JTH	J24189037		1-	A	G1
R 1002	CHIPRES.	10k	1/16W	5%	RMC1/16S 103JTH	J24189037		1-	A	G1
R 1003	CHIPRES.	10k	1/16W	5%	RMC1/16S 103JTH	J24189037		1-	A	G1
R 1004	CHIPRES.	33k	1/16W	5%	RMC1/16S 333JTH	J24189043		1-	A	G1
R 1005	CHIPRES.	330	1/16W	5%	RMC1/16S 331JTH	J24189019		1-	A	F1
R 1006	CHIPRES.	330	1/16W	5%	RMC1/16S 331JTH	J24189019		1-	A	F1
R 1007	CHIPRES.	10k	1/16W	5%	RMC1/16S 103JTH	J24189037		1-	A	G1
R 1008	CHIPRES.	220k	1/16W	5%	RMC1/16S 224JTH	J24189053		1-	A	G1
R 1009	CHIPRES.	100	1/16W	5%	RMC1/16S 101JTH	J24189013		1-	A	G1
R 1010	CHIPRES.	100	1/16W	5%	RMC1/16S 101JTH	J24189013		1-	A	G1
R 1011	CHIPRES.	1k	1/16W	5%	RMC1/16S 102JTH	J24189025		1-	A	F1
R 1012	CHIPRES.	22k	1/16W	5%	RMC1/16S 223JTH	J24189041		1-	A	F1
R 1013	CHIPRES.	10k	1/16W	5%	RMC1/16S 103JTH	J24189037		1-	B	b1
R 1014	CHIPRES.	47k	1/16W	5%	RMC1/16S 473JTH	J24189045		1-	B	d1
R 1015	CHIPRES.	82	1/16W	5%	RMC1/16S 820JTH	J24189012		1-	A	F1
R 1016	CHIPRES.	100	1/16W	5%	RMC1/16S 101JTH	J24189013		1-	B	c1

MAIN Unit

Parts List

REF	DESCRIPTION	VALUE	V/W	TOL.	MFR'S DESIG	VXSTD P/N	VERS.	LOT	SIDE	LAY ADR
R 1017	CHIPRES.	33k	1/16W	5%	RMC1/16S 333JTH	J24189043		1-	B	b1
R 1018	CHIPRES.	330	1/16W	5%	RMC1/16S 331JTH	J24189019		1-	B	d1
R 1020	CHIPRES.	330	1/16W	5%	RMC1/16S 331JTH	J24189019		1-	B	d1
R 1021	CHIPRES.	100	1/16W	5%	RMC1/16S 101JTH	J24189013		1-	B	e1
R 1022	CHIPRES.	470	1/16W	5%	RMC1/16S 471JTH	J24189021		1-	B	d1
R 1023	CHIPRES.	22k	1/16W	5%	RMC1/16S 223JTH	J24189041		1-	B	e1
R 1024	CHIPRES.	470	1/16W	5%	RMC1/16S 471JTH	J24189021		1-	B	e1
R 1025	CHIPRES.	470	1/16W	5%	RMC1/16S 471JTH	J24189021		1-	B	e1
R 1026	CHIPRES.	47	1/16W	5%	RMC1/16S 470JTH	J24189009		1-	B	e1
R 1027	CHIPRES.	10k	1/16W	5%	RMC1/16S 103JTH	J24189037		1-	B	e1
R 1028	CHIPRES.	47	1/16W	5%	RMC1/16S 470JTH	J24189009		1-	B	f1
R 1029	CHIPRES.	220k	1/16W	5%	RMC1/16S 224JTH	J24189053		1-	B	f1
R 1030	CHIPRES.	470	1/16W	5%	RMC1/16S 471JTH	J24189021		1-	B	f1
R 1031	CHIPRES.	220	1/16W	5%	RMC1/16S 221JTH	J24189017		1-	B	f1
R 1032	CHIPRES.	15k	1/16W	5%	RMC1/16S 153JTH	J24189039		1-	B	f1
R 1032	CHIPRES.	15k	1/16W	0.5%	RR0510R-153-D	J24189147		43-	B	f1
R 1033	CHIPRES.	22k	1/16W	5%	RMC1/16S 223JTH	J24189041		1-	B	f2
R 1033	CHIPRES.	22k	1/16W	0.5%	RR0510R-223-D	J24189151		43-	B	f2
R 1034	CHIPRES.	680	1/16W	5%	RMC1/16S 681JTH	J24189023		1-	B	f1
R 1034	CHIPRES.	680	1/16W	0.5%	RR0510P-681-D	J24189115		43-	B	f1
R 1036	CHIPRES.	100	1/16W	5%	RMC1/16S 101JTH	J24189013		1-	B	f2
R 1037	CHIPRES.	2.2k	1/16W	5%	RMC1/16S 222JTH	J24189029		1-	B	f1
R 1038	CHIPRES.	47k	1/16W	5%	RMC1/16S 473JTH	J24189045		1-	B	f2
R 1039	CHIPRES.	47k	1/16W	5%	RMC1/16S 473JTH	J24189045		1-	B	f1
R 1040	CHIPRES.	150	1/16W	5%	RMC1/16S 151JTH	J24189015		1-	B	f1
R 1041	CHIPRES.	100	1/16W	5%	RMC1/16S 101JTH	J24189013		1-	B	g1
R 1042	CHIPRES.	2.2k	1/16W	5%	RMC1/16S 222JTH	J24189029		1-	B	f1
R 1043	CHIPRES.	2.2k	1/16W	5%	RMC1/16S 222JTH	J24189029		1-	B	g1
R 1044	CHIPRES.	470	1/16W	5%	RMC1/16S 471JTH	J24189021		1-	B	g1
R 1045	CHIPRES.	330	1/16W	5%	RMC1/16S 331JTH	J24189019		1-	B	g1
R 1046	CHIPRES.	680	1/16W	5%	RMC1/16S 681JTH	J24189023		1-	B	g1
R 1047	CHIPRES.	100	1/16W	5%	RMC1/16S 101JTH	J24189013		1-	B	g1
R 1048	CHIPRES.	100	1/16W	5%	RMC1/16S 101JTH	J24189013		1-	B	f1
R 1049	CHIPRES.	1k	1/16W	5%	RMC1/16S 102JTH	J24189025		1-	B	f1
R 1050	CHIPRES.	470k	1/16W	5%	RMC1/16S 474JTH	J24189057		1-	B	f1
R 1051	CHIPRES.	22k	1/16W	5%	RMC1/16S 223JTH	J24189041		1-	B	g2
R 1052	CHIPRES.	100k	1/16W	5%	RMC1/16S 104JTH	J24189049		1-	B	f2
R 1053	CHIPRES.	220k	1/16W	5%	RMC1/16S 224JTH	J24189053		1-	B	g2
R 1054	CHIPRES.	100	1/16W	5%	RMC1/16S 101JTH	J24189013		1-	B	g1
R 1055	CHIPRES.	820k	1/16W	5%	RMC1/16S 824JTH	J24189060		1-	B	g1
R 1056	CHIPRES.	47k	1/16W	5%	RMC1/16S 473JTH	J24189045		1-	B	g2
R 1057	CHIPRES.	47k	1/16W	5%	RMC1/16S 473JTH	J24189045		1-	B	g2
R 1058	CHIPRES.	47k	1/16W	5%	RMC1/16S 473JTH	J24189045		1-	B	g2
R 1059	CHIPRES.	100	1/16W	5%	RMC1/16S 101JTH	J24189013		1-	B	g2
R 1060	CHIPRES.	100	1/16W	5%	RMC1/16S 101JTH	J24189013		1-	B	g1
R 1061	CHIPRES.	22k	1/16W	5%	RMC1/16S 223JTH	J24189041		1-	B	g1
R 1062	CHIPRES.	100k	1/16W	5%	RMC1/16S 104JTH	J24189049		1-	B	g1
R 1063	CHIPRES.	100k	1/16W	5%	RMC1/16S 104JTH	J24189049		1-	B	h2
R 1064	CHIPRES.	100k	1/16W	5%	RMC1/16S 104JTH	J24189049		1-	B	g2
R 1065	CHIPRES.	47k	1/16W	5%	RMC1/16S 473JTH	J24189045		1-	B	h1
R 1066	CHIPRES.	470k	1/16W	5%	RMC1/16S 474JTH	J24189057		1-	B	h1
R 1067	CHIPRES.	820k	1/16W	5%	RMC1/16S 824JTH	J24189060		1-	B	h1
R 1068	CHIPRES.	470k	1/16W	5%	RMC1/16S 474JTH	J24189057		1-	B	h1
R 1069	CHIPRES.	100k	1/16W	5%	RMC1/16S 104JTH	J24189049		1-	B	h2
R 1070	CHIPRES.	330k	1/16W	0.5%	MCR01MZPD3303	J24189330		1-	B	g1
R 1071	CHIPRES.	330k	1/16W	0.5%	MCR01MZPD3303	J24189330		1-	B	g1
R 1072	CHIPRES.	470k	1/16W	5%	RMC1/16S 474JTH	J24189057		1-	A	F1
R 1073	CHIPRES.	100k	1/16W	5%	RMC1/16S 104JTH	J24189049		1-	B	c1
R 1074	CHIPRES.	100k	1/16W	5%	RMC1/16S 104JTH	J24189049		1-	B	b2
R 1076	CHIPRES.	47k	1/16W	5%	RMC1/16S 473JTH	J24189045		1-	B	b2
R 1077	CHIPRES.	150k	1/16W	5%	RMC1/16S 154JTH	J24189051		1-	B	c2
R 1078	CHIPRES.	47	1/16W	5%	RMC1/16S 470JTH	J24189009		1-	B	c2
R 1079	CHIPRES.	100	1/16W	5%	RMC1/16S 101JTH	J24189013		1-	B	c2
R 1080	CHIPRES.	150k	1/16W	5%	RMC1/16S 154JTH	J24189051		1-	B	c2
R 1081	CHIPRES.	680	1/16W	5%	RMC1/16S 681JTH	J24189023		1-	B	c2
R 1082	CHIPRES.	100	1/16W	5%	RMC1/16S 101JTH	J24189013		1-	B	c2
R 1083	CHIPRES.	22	1/16W	5%	RMC1/16S 220JTH	J24189005		1-	B	c2
R 1084	CHIPRES.	22k	1/16W	5%	RMC1/16S 223JTH	J24189041		1-	A	F1
R 1085	CHIPRES.	100k	1/16W	5%	RMC1/16S 104JTH	J24189049		1-	B	c1
R 1086	CHIPRES.	100k	1/16W	5%	RMC1/16S 104JTH	J24189049		1-	B	c1
R 1087	CHIPRES.	100k	1/16W	5%	RMC1/16S 104JTH	J24189049		1-	B	c1
R 1088	CHIPRES.	150k	1/16W	5%	RMC1/16S 154JTH	J24189051		1-	B	d1
R 1089	CHIPRES.	47k	1/16W	5%	RMC1/16S 473JTH	J24189045		1-	B	d1

MAIN Unit

Parts List

REF	DESCRIPTION	VALUE	V/W	TOL.	MFR'S DESIG	VXSTD P/N	VERS.	LOT	SIDE	LAY ADR
R 1090	CHIPRES.	39k	1/16W	5%	RMC1/16S 393JTH	J24189044		1-	B	d1
R 1091	CHIPRES.	150	1/16W	5%	RMC1/16S 151JTH	J24189015		1-	B	d1
R 1092	CHIPRES.	100	1/16W	5%	RMC1/16S 101JTH	J24189013		1-	B	d1
R 1093	CHIPRES.	2.2k	1/16W	5%	RMC1/16S 222JTH	J24189029		1-	B	d1
R 1094	CHIPRES.	1k	1/16W	5%	RMC1/16S 102JTH	J24189025		1-	B	d1
R 1095	CHIPRES.	470	1/16W	5%	RMC1/16S 471JTH	J24189021		1-	B	d1
R 1096	CHIPRES.	1k	1/16W	5%	RMC1/16S 102JTH	J24189025		1-	A	C1
R 1097	CHIPRES.	220	1/16W	5%	RMC1/16S 221JTH	J24189017		1-	A	C1
R 1098	CHIPRES.	470k	1/16W	5%	RMC1/16S 474JTH	J24189057		1-	A	C1
R 1099	CHIPRES.	1.5k	1/16W	5%	RMC1/16S 152JTH	J24189027		1-	A	C1
R 1100	CHIPRES.	47	1/16W	5%	RMC1/16S 470JTH	J24189009		1-	B	e2
R 1101	CHIPRES.	1k	1/16W	5%	RMC1/16S 102JTH	J24189025		1-	B	g3
R 1102	CHIPRES.	10k	1/16W	5%	RMC1/16S 103JTH	J24189037		1-	B	g3
R 1102	CHIPRES.	4.7k	1/16W	5%	RMC1/16S 472JTH	J24189033		4-	B	g3
R 1103	CHIPRES.	10k	1/16W	5%	RMC1/16S 103JTH	J24189037		1-3	B	g2
R 1104	CHIPRES.	10k	1/16W	5%	RMC1/16S 103JTH	J24189037		1-3	B	g3
R 1105	CHIPRES.	10k	1/16W	5%	RMC1/16S 103JTH	J24189037		1-3	B	g2
R 1106	CHIPRES.	10k	1/16W	5%	RMC1/16S 103JTH	J24189037		1-3	B	h3
R 1107	CHIPRES.	10k	1/16W	5%	RMC1/16S 103JTH	J24189037		1-	B	g3
R 1107	CHIPRES.	4.7k	1/16W	5%	RMC1/16S 472JTH	J24189033		4-	B	g3
R 1108	CHIPRES.	150k	1/16W	5%	RMC1/16S 154JTH	J24189051		1-	B	g3
R 1109	CHIPRES.	2.2k	1/16W	5%	RMC1/16S 222JTH	J24189029		1-	B	f2
R 1110	CHIPRES.	2.2k	1/16W	5%	RMC1/16S 222JTH	J24189029		1-	B	f2
R 1111	CHIPRES.	15k	1/16W	5%	RMC1/16S 153JTH	J24189039		1-	B	f2
R 1112	CHIPRES.	1k	1/16W	5%	RMC1/16S 102JTH	J24189025		1-	B	g2
R 1113	CHIPRES.	10k	1/16W	5%	RMC1/16S 103JTH	J24189037		1-	B	g2
R 1114	CHIPRES.	5.6k	1/16W	5%	RMC1/16S 562JTH	J24189034		1-	B	g2
R 1115	CHIPRES.	10k	1/16W	5%	RMC1/16S 103JTH	J24189037		1-	B	g3
R 1116	CHIPRES.	2.2k	1/16W	5%	RMC1/16S 222JTH	J24189029		1-	A	F2
R 1117	CHIPRES.	100k	1/16W	5%	RMC1/16S 104JTH	J24189049		1-	A	G2
R 1118	CHIPRES.	47k	1/16W	5%	RMC1/16S 473JTH	J24189045		1-	A	F2
R 1119	CHIPRES.	100k	1/16W	5%	RMC1/16S 104JTH	J24189049		1-	A	F2
R 1120	CHIPRES.	10k	1/16W	5%	RMC1/16S 103JTH	J24189037		1-	A	F2
R 1121	CHIPRES.	33k	1/16W	5%	RMC1/16S 333JTH	J24189043		1-	B	h2
R 1122	CHIPRES.	470k	1/16W	5%	RMC1/16S 474JTH	J24189057		1-	B	e2
R 1123	CHIPRES.	22k	1/16W	5%	RMC1/16S 223JTH	J24189041		1-	B	c2
R 1124	CHIPRES.	33k	1/16W	5%	RMC1/16S 333JTH	J24189043		1-	A	C3
R 1125	CHIPRES.	47k	1/16W	5%	RMC1/16S 473JTH	J24189045		1-	A	C2
R 1126	CHIPRES.	3.3k	1/16W	5%	RMC1/16S 332JTH	J24189031		1-	A	C2
R 1127	CHIPRES.	10k	1/16W	5%	RMC1/16S 103JTH	J24189037		1-	B	f2
R 1128	CHIPRES.	1.5M	1/16W	5%	RMC1/16S 155JTH	J24189063		1-	B	e2
R 1129	CHIPRES.	820k	1/16W	0.5%	MCR01MZPD8203	J24189336		1-	B	e2
R 1130	CHIPRES.	390k	1/16W	0.5%	MCR01MZPD3903	J24189331		1-	B	e2
R 1131	CHIPRES.	100k	1/16W	0.5%	RR0510R-104-D	J24189167		1-	B	e2
R 1131	CHIPRES.	100k	1/16W	0.5%	MCR01MZPD1003	J24189386		46-	B	e2
R 1132	CHIPRES.	100k	1/16W	0.5%	RR0510R-104-D	J24189167		1-	B	e2
R 1132	CHIPRES.	100k	1/16W	0.5%	MCR01MZPD1003	J24189386		46-	B	e2
R 1133	CHIPRES.	100k	1/16W	0.5%	RR0510R-104-D	J24189167		1-	B	e2
R 1133	CHIPRES.	100k	1/16W	0.5%	MCR01MZPD1003	J24189386		46-	B	e2
R 1134	CHIPRES.	100k	1/16W	0.5%	RR0510R-104-D	J24189167		1-	B	e2
R 1134	CHIPRES.	100k	1/16W	0.5%	MCR01MZPD1003	J24189386		46-	B	e2
R 1135	CHIPRES.	100k	1/16W	0.5%	RR0510R-104-D	J24189167		1-	B	e2
R 1135	CHIPRES.	100k	1/16W	0.5%	MCR01MZPD1003	J24189386		46-	B	e2
R 1136	CHIPRES.	10k	1/16W	5%	RMC1/16S 103JTH	J24189037		1-	A	F2
R 1137	CHIPRES.	220	1/16W	5%	RMC1/16S 221JTH	J24189017		1-	A	F2
R 1138	CHIPRES.	2.2k	1/16W	5%	RMC1/16S 222JTH	J24189029		1-	A	F2
R 1139	CHIPRES.	4.7k	1/16W	5%	RMC1/16S 472JTH	J24189033		1-	A	F2
R 1142	CHIPRES.	1k	1/16W	5%	RMC1/16S 102JTH	J24189025		1-	A	G2
R 1143	CHIPRES.	1k	1/16W	5%	RMC1/16S 102JTH	J24189025		1-	A	G2
R 1144	CHIPRES.	33k	1/16W	5%	RMC1/16S 333JTH	J24189043		1-	A	G2
R 1145	CHIPRES.	100k	1/16W	5%	RMC1/16S 104JTH	J24189049		1-	A	H3
R 1146	CHIPRES.	100k	1/16W	5%	RMC1/16S 104JTH	J24189049		1-	A	H3
R 1147	CHIPRES.	100	1/16W	5%	RMC1/16S 101JTH	J24189013		1-	A	H2
R 1148	CHIPRES.	100k	1/16W	5%	RMC1/16S 104JTH	J24189049		1-	A	G2
R 1149	CHIPRES.	4.7	1/16W	5%	RMC1/16S 4R7JTH	J24189066		1-	A	G2
R 1150	CHIPRES.	4.7	1/16W	5%	RMC1/16S 4R7JTH	J24189066		1-	A	G2
R 1151	CHIPRES.	15k	1/16W	5%	RMC1/16S 153JTH	J24189039		1-	A	G3
R 1152	CHIPRES.	100	1/16W	5%	RMC1/16S 101JTH	J24189013		1-	A	G3
R 1153	CHIPRES.	15k	1/16W	5%	RMC1/16S 153JTH	J24189039		1-	A	G3
R 1154	CHIPRES.	100k	1/16W	5%	RMC1/16S 104JTH	J24189049		1-	B	f4
R 1155	CHIPRES.	10k	1/16W	5%	RMC1/16S 103JTH	J24189037		1-	B	f4
R 1156	CHIPRES.	2.2M	1/16W	5%	RMC1/16S 225JTH	J24189065		1-	B	g4
R 1157	CHIPRES.	150k	1/16W	5%	RMC1/16S 154JTH	J24189051		1-	B	g4

MAIN Unit

Parts List

REF	DESCRIPTION	VALUE	V/W	TOL.	MFR'S DESIG	VXSTD P/N	VERS.	LOT	SIDE	LAY ADR
R 1158	CHIPRES.	33k	1/16W	5%	RMC1/16S 333JTH	J24189043		1-	B	g3
R 1159	CHIPRES.	10k	1/16W	5%	RMC1/16S 103JTH	J24189037		1-	B	g3
R 1160	CHIPRES.	2.7k	1/16W	5%	RMC1/16S 272JTH	J24189030		1-	B	g3
R 1161	CHIPRES.	470k	1/16W	5%	RMC1/16S 474JTH	J24189057		1-	B	g3
R 1162	CHIPRES.	330	1/16W	5%	RMC1/16S 331JTH	J24189019		1-	B	g3
R 1163	CHIPRES.	10k	1/16W	5%	RMC1/16S 103JTH	J24189037		1-	B	g3
R 1164	CHIPRES.	47k	1/16W	5%	RMC1/16S 473JTH	J24189045		1-	B	d2
R 1165	CHIPRES.	470k	1/16W	5%	RMC1/16S 474JTH	J24189057		1-	A	G3
R 1166	CHIPRES.	1k	1/16W	5%	RMC1/16S 102JTH	J24189025		1-	A	G3
R 1167	CHIPRES.	10k	1/16W	0.5%	RR0510P-103-D	J24189143		1-	B	d4
R 1168	CHIPRES.	22k	1/16W	0.5%	RR0510R-223-D	J24189151		1-	B	d3
R 1169	CHIPRES.	470k	1/16W	0.5%	MCR01MZPD4703	J24189332		1-	B	d3
R 1170	CHIPRES.	100k	1/16W	0.5%	RR0510R-104-D	J24189167		1-	B	d3
R 1170	CHIPRES.	100k	1/16W	0.5%	MCR01MZPD1003	J24189386		46-	B	d3
R 1171	CHIPRES.	33k	1/16W	0.5%	RR0510R-333-D	J24189155		1-	B	d3
R 1172	CHIPRES.	680	1/16W	0.5%	RR0510P-681-D	J24189115		1-	B	d3
R 1173	CHIPRES.	10k	1/16W	5%	RMC1/16S 103JTH	J24189037		1-	B	d3
R 1175	CHIPRES.	100k	1/16W	5%	RMC1/16S 104JTH	J24189049		1-	B	d4
R 1176	CHIPRES.	33k	1/16W	0.5%	RR0510R-333-D	J24189155		1-	B	d3
R 1177	CHIPRES.	470k	1/16W	5%	RMC1/16S 474JTH	J24189057		1-	A	D1
R 1178	CHIPRES.	10k	1/16W	5%	RMC1/16S 103JTH	J24189037		1-	A	E1
R 1179	CHIPRES.	68k	1/16W	5%	RMC1/16S 683JTH	J24189047		1-	A	E1
R 1180	CHIPRES.	22k	1/16W	5%	RMC1/16S 223JTH	J24189041		1-	A	D1
R 1181	CHIPRES.	470k	1/16W	5%	RMC1/16S 474JTH	J24189057		1-	A	D1
R 1182	CHIPRES.	470k	1/16W	5%	RMC1/16S 474JTH	J24189057		1-	A	D1
R 1183	CHIPRES.	22k	1/16W	5%	RMC1/16S 223JTH	J24189041		1-	A	D1
R 1184	CHIPRES.	33k	1/16W	5%	RMC1/16S 333JTH	J24189043		1-	A	D2
R 1185	CHIPRES.	4.7k	1/16W	5%	RMC1/16S 472JTH	J24189033		1-	A	H3
R 1186	CHIPRES.	1k	1/16W	5%	RMC1/16S 102JTH	J24189025		1-	A	H3
R 1187	CHIPRES.	2.2k	1/16W	5%	RMC1/16S 222JTH	J24189029		1-	A	H3
R 1188	CHIPRES.	10k	1/16W	0.5%	RR0510P-103-D	J24189143		1-	A	H3
R 1189	CHIPRES.	4.7k	1/16W	0.5%	RR0510P-472-D	J24189135		1-	A	H3
R 1190	CHIPRES.	470	1/16W	5%	RMC1/16S 471JTH	J24189021		1-	A	G3
R 1191	CHIPRES.	47k	1/16W	0.5%	RR0510R-473-D	J24189159		1-	B	c3
R 1192	CHIPRES.	100k	1/16W	5%	RMC1/16S 104JTH	J24189049		1-	A	D3
R 1194	CHIPRES.	100k	1/16W	0.5%	RR0510R-104-D	J24189167		1-	A	D2
R 1194	CHIPRES.	100k	1/16W	0.5%	MCR01MZPD1003	J24189386		46-	A	D2
R 1195	CHIPRES.	56k	1/16W	5%	RMC1/16S 563JTH	J24189046		1-	A	E1
R 1196	CHIPRES.	33k	1/16W	5%	RMC1/16S 333JTH	J24189043		1-	B	c2
R 1197	CHIPRES.	100k	1/16W	5%	RMC1/16S 104JTH	J24189049		1-	A	E3
R 1198	CHIPRES.	470k	1/16W	5%	RMC1/16S 474JTH	J24189057		1-	A	E3
R 1199	CHIPRES.	470k	1/16W	5%	RMC1/16S 474JTH	J24189057		1-	A	F3
R 1200	CHIPRES.	330k	1/16W	5%	RMC1/16S 334JTH	J24189055		1-	B	f4
R 1201	CHIPRES.	330k	1/16W	5%	RMC1/16S 334JTH	J24189055		1-	B	f4
R 1202	CHIPRES.	33k	1/16W	5%	RMC1/16S 333JTH	J24189043		1-	B	f4
R 1203	CHIPRES.	220k	1/16W	5%	RMC1/16S 224JTH	J24189053		1-	B	f4
R 1204	CHIPRES.	100k	1/16W	5%	RMC1/16S 104JTH	J24189049		1-	B	e4
R 1205	CHIPRES.	2.2k	1/16W	5%	RMC1/16S 222JTH	J24189029		1-	B	c4
R 1206	CHIPRES.	2.2k	1/16W	5%	RMC1/16S 222JTH	J24189029		1-	A	F3
R 1207	CHIPRES.	3.3k	1/16W	5%	RMC1/16S 332JTH	J24189031		1-	B	c3
R 1208	CHIPRES.	470	1/16W	5%	RMC1/16S 471JTH	J24189021		1-	A	F3
R 1209	CHIPRES.	22k	1/16W	5%	RMC1/16S 223JTH	J24189041		1-	A	F3
R 1210	CHIPRES.	10k	1/16W	5%	RMC1/16S 103JTH	J24189037		1-	A	F3
R 1211	CHIPRES.	10k	1/16W	5%	RMC1/16S 103JTH	J24189037		1-	B	c4
R 1212	CHIPRES.	15k	1/16W	5%	RMC1/16S 153JTH	J24189039		1-	B	c3
R 1213	CHIPRES.	2.2M	1/16W	5%	RMC1/16S 225JTH	J24189065		1-	B	c3
R 1214	CHIPRES.	4.7k	1/16W	5%	RMC1/16S 472JTH	J24189033		1-	B	b3
R 1215	CHIPRES.	100k	1/16W	5%	RMC1/16S 104JTH	J24189049		1-	A	F3
R 1216	CHIPRES.	1k	1/16W	5%	RMC1/16S 102JTH	J24189025		1-	A	F4
R 1217	CHIPRES.	1k	1/16W	5%	RMC1/16S 102JTH	J24189025		1-	A	F4
R 1218	CHIPRES.	470k	1/16W	5%	RMC1/16S 474JTH	J24189057		1-	A	F4
R 1219	CHIPRES.	6.8	1/2W	5%	RMC1/26R8JCTP	J24275689		1-	A	G4
R 1220	CHIPRES.	2.2k	1/16W	5%	RMC1/16S 222JTH	J24189029		1-	A	G4
R 1221	CHIPRES.	100	1/16W	5%	RMC1/16S 101JTH	J24189013		1-	A	G4
R 1222	CHIPRES.	2.2k	1/16W	5%	RMC1/16S 222JTH	J24189029		1-	B	b3
R 1223	CHIPRES.	1M	1/16W	5%	RMC1/16S 105JTH	J24189061		1-	B	b3
R 1224	CHIPRES.	1.2M	1/16W	5%	RMC1/16S 125JTH	J24189062		1-	B	b3
R 1225	CHIPRES.	10k	1/16W	5%	RMC1/16S 103JTH	J24189037		1-	B	b3
R 1226	CHIPRES.	2.2M	1/16W	5%	RMC1/16S 225JTH	J24189065		1-	B	b3
R 1227	CHIPRES.	100k	1/16W	0.5%	RR0510R-104-D	J24189167		1-	A	F3
R 1227	CHIPRES.	100k	1/16W	0.5%	MCR01MZPD1003	J24189386		46-	A	F3
R 1228	CHIPRES.	10k	1/16W	0.5%	RR0510P-103-D	J24189143		1-	A	F3
R 1229	CHIPRES.	100k	1/16W	5%	RMC1/16S 104JTH	J24189049		1-	B	b3

MAIN Unit

Parts List

REF	DESCRIPTION	VALUE	V/W	TOL.	MFR'S DESIG	VXSTD P/N	VERS.	LOT	SIDE	LAY ADR
R 1230	CHIPRES.	68k	1/16W	0.5%	RR0510R-683-D	J24189163		1-	B	b2
R 1231	CHIPRES.	10k	1/16W	0.5%	RR0510P-103-D	J24189143		1-	B	b2
R 1232	CHIPRES.	4.7k	1/16W	0.5%	RR0510P-472-D	J24189135		1-	B	c3
R 1233	CHIPRES.	4.7k	1/16W	0.5%	RR0510P-472-D	J24189135		1-	B	c3
R 1234	CHIPRES.	3.3k	1/16W	0.5%	RR0510P-332-D	J24189131		1-	B	c3
R 1235	CHIPRES.	68k	1/16W	5%	RMC1/16S 683JTH	J24189047		1-	B	c3
R 1236	CHIPRES.	220k	1/16W	5%	RMC1/16S 224JTH	J24189053		1-	B	c3
R 1237	CHIPRES.	330k	1/16W	5%	RMC1/16S 334JTH	J24189055		1-	B	c3
R 1238	CHIPRES.	220k	1/16W	5%	RMC1/16S 224JTH	J24189053		1-	B	c3
R 1239	CHIPRES.	10k	1/16W	5%	RMC1/16S 103JTH	J24189037		1-	B	c3
R 1240	CHIPRES.	68k	1/16W	5%	RMC1/16S 683JTH	J24189047		1-	B	c3
R 1241	CHIPRES.	56k	1/16W	0.5%	RR0510R-563-D	J24189161		1-	A	E3
R 1242	CHIPRES.	330k	1/16W	5%	RMC1/16S 334JTH	J24189055		1-	B	c3
R 1243	CHIPRES.	100k	1/16W	0.5%	RR0510R-104-D	J24189167		1-	A	E3
R 1243	CHIPRES.	100k	1/16W	0.5%	MCR01MZPD1003	J24189386		46-	A	E3
R 1244	CHIPRES.	330k	1/16W	5%	RMC1/16S 334JTH	J24189055		1-	B	c3
R 1245	CHIPRES.	22k	1/16W	5%	RMC1/16S 223JTH	J24189041		1-	B	c3
R 1246	CHIPRES.	68k	1/16W	0.5%	RR0510R-683-D	J24189163		1-	A	D2
R 1247	CHIPRES.	470k	1/16W	5%	RMC1/16S 474JTH	J24189057		1-	A	C3
R 1248	CHIPRES.	470k	1/16W	5%	RMC1/16S 474JTH	J24189057		1-	A	D3
R 1249	CHIPRES.	470k	1/16W	5%	RMC1/16S 474JTH	J24189057		1-	A	C3
R 1250	CHIPRES.	47k	1/16W	5%	RMC1/16S 473JTH	J24189045		1-	A	C3
R 1251	CHIPRES.	22k	1/16W	5%	RMC1/16S 223JTH	J24189041		1-	B	d2
R 1252	CHIPRES.	150k	1/16W	5%	RMC1/16S 154JTH	J24189051		1-	B	d2
R 1253	CHIPRES.	470k	1/16W	5%	RMC1/16S 474JTH	J24189057		1-	B	d2
R 1254	CHIPRES.	150k	1/16W	5%	RMC1/16S 154JTH	J24189051		1-	B	d2
R 1255	CHIPRES.	68k	1/16W	5%	RMC1/16S 683JTH	J24189047		1-	B	c2
R 1256	CHIPRES.	390k	1/16W	5%	RMC1/16S 394JTH	J24189056		1-	B	c2
R 1257	CHIPRES.	390k	1/16W	5%	RMC1/16S 394JTH	J24189056		1-	B	c2
R 1258	CHIPRES.	47k	1/16W	5%	RMC1/16S 473JTH	J24189045		1-	B	c2
R 1259	CHIPRES.	390k	1/16W	5%	RMC1/16S 394JTH	J24189056		1-	B	c3
R 1260	CHIPRES.	390k	1/16W	5%	RMC1/16S 394JTH	J24189056		1-	B	c3
R 1261	CHIPRES.	10k	1/16W	5%	RMC1/16S 103JTH	J24189037		1-	B	c3
R 1262	CHIPRES.	120k	1/16W	5%	RMC1/16S 124JTH	J24189050		1-	B	c3
R 1263	CHIPRES.	10k	1/16W	5%	RMC1/16S 103JTH	J24189037		1-	A	E3
R 1264	CHIPRES.	39k	1/16W	5%	RMC1/16S 393JTH	J24189044		1-	A	E3
R 1265	CHIPRES.	22k	1/16W	5%	RMC1/16S 223JTH	J24189041		1-	B	d2
R 1266	CHIPRES.	1k	1/16W	5%	RMC1/16S 102JTH	J24189025		1-	B	c2
R 1267	CHIPRES.	470k	1/16W	5%	RMC1/16S 474JTH	J24189057		1-	B	d2
R 1268	CHIPRES.	47k	1/16W	5%	RMC1/16S 473JTH	J24189045		1-	B	d2
R 1269	CHIPRES.	47k	1/16W	5%	RMC1/16S 473JTH	J24189045		1-	B	d2
R 1270	CHIPRES.	10k	1/16W	5%	RMC1/16S 103JTH	J24189037		1-	B	d2
R 1271	CHIPRES.	39k	1/16W	5%	RMC1/16S 393JTH	J24189044		1-	B	d2
R 1272	CHIPRES.	10k	1/16W	0.5%	RR0510P-103-D	J24189143		1-	B	c2
R 1273	CHIPRES.	1k	1/16W	5%	RMC1/16S 102JTH	J24189025		1-	A	D2
R 1274	CHIPRES.	10k	1/16W	0.5%	RR0510P-103-D	J24189143		1-	A	E1
R 1275	CHIPRES.	33k	1/16W	5%	RMC1/16S 333JTH	J24189043		1-	B	c2
R 1276	CHIPRES.	47k	1/16W	5%	RMC1/16S 473JTH	J24189045		1-	B	c2
R 1277	CHIPRES.	1k	1/16W	5%	RMC1/16S 102JTH	J24189025		1-	A	D2
R 1278	CHIPRES.	68k	1/16W	0.5%	RR0510R-683-D	J24189163		1-	A	D1
R 1279	CHIPRES.	22k	1/16W	5%	RMC1/16S 223JTH	J24189041		1-	A	D3
R 1280	CHIPRES.	47k	1/16W	5%	RMC1/16S 473JTH	J24189045		1-	A	D2
R 1281	CHIPRES.	47k	1/16W	5%	RMC1/16S 473JTH	J24189045		1-	A	D2
R 1282	CHIPRES.	47k	1/16W	5%	RMC1/16S 473JTH	J24189045		1-	A	D2
R 1283	CHIPRES.	47k	1/16W	5%	RMC1/16S 473JTH	J24189045		1-	A	D2
R 1285	CHIPRES.	1M	1/16W	5%	RMC1/16S 105JTH	J24189061		1-	B	d2
R 1286	CHIPRES.	100k	1/16W	5%	RMC1/16S 104JTH	J24189049		1-	A	D3
R 1288	CHIPRES.	0	1/16W	5%	RMC1/16S JPTH	J24189070		1-	A	C3
R 1289	CHIPRES.	0	1/16W	5%	RMC1/16S JPTH	J24189070		1-	B	e3
R 1290	CHIPRES.	0	1/16W	5%	RMC1/16S JPTH	J24189070		1-	B	e3
R 1291	CHIPRES.	100k	1/16W	5%	RMC1/16S 104JTH	J24189049		1-	A	C3
R 1292	CHIPRES.	470k	1/16W	5%	RMC1/16S 474JTH	J24189057		1-	A	C3
R 1293	CHIPRES.	470	1/16W	5%	RMC1/16S 471JTH	J24189021		1-	A	G4
R 1294	CHIPRES.	470	1/16W	5%	RMC1/16S 471JTH	J24189021		1-	A	G3
R 1295	CHIPRES.	330	1/16W	5%	RMC1/16S 331JTH	J24189019		1-	A	G4
R 1296	CHIPRES.	330	1/16W	5%	RMC1/16S 331JTH	J24189019		1-	A	G3
R 1297	CHIPRES.	470	1/16W	5%	RMC1/16S 471JTH	J24189021		1-	A	F3
R 1298	CHIPRES.	470	1/16W	5%	RMC1/16S 471JTH	J24189021		1-	A	F3
R 1299	CHIPRES.	220	1/16W	5%	RMC1/16S 221JTH	J24189017		1-	B	h2
R 1300	CHIPRES.	220	1/16W	5%	RMC1/16S 221JTH	J24189017		1-	A	A4
R 1301	CHIPRES.	220	1/16W	5%	RMC1/16S 221JTH	J24189017		1-	A	C1
R 1302	CHIPRES.	330	1/16W	5%	RMC1/16S 331JTH	J24189019		1-	A	C1
R 1303	CHIPRES.	150	1/16W	5%	RMC1/16S 151JTH	J24189015		1-	A	C1

MAIN Unit

Parts List

REF	DESCRIPTION	VALUE	V/W	TOL.	MFR'S DESIG	VXSTD P/N	VERS.	LOT	SIDE	LAY ADR
R 1304	CHIPRES.	100k	1/16W	0.5%	RR0510R-104-D	J24189167		1-	A	D2
R 1304	CHIPRES.	100k	1/16W	0.5%	MCR01MZPD1003	J24189386		46-	A	D2
R 1305	CHIPRES.	100k	1/16W	0.5%	RR0510R-104-D	J24189167		1-	A	D1
R 1305	CHIPRES.	100k	1/16W	0.5%	MCR01MZPD1003	J24189386		46-	A	D1
R 1306	CHIPRES.	100k	1/16W	0.5%	RR0510R-104-D	J24189167		1-	A	D2
R 1306	CHIPRES.	100k	1/16W	0.5%	MCR01MZPD1003	J24189386		46-	A	D2
R 1307	CHIPRES.	100k	1/16W	0.5%	RR0510R-104-D	J24189167		1-	A	E2
R 1307	CHIPRES.	100k	1/16W	0.5%	MCR01MZPD1003	J24189386		46-	A	E2
R 1308	CHIPRES.	1k	1/16W	5%	RMC1/16S 102JTH	J24189025		1-	A	D2
R 1309	CHIPRES.	1k	1/16W	5%	RMC1/16S 102JTH	J24189025		1-	A	D2
R 1310	CHIPRES.	1k	1/16W	5%	RMC1/16S 102JTH	J24189025		1-	A	D2
R 1311	CHIPRES.	1k	1/16W	5%	RMC1/16S 102JTH	J24189025		1-	A	D2
R 1312	CHIPRES.	1k	1/16W	5%	RMC1/16S 102JTH	J24189025		1-	A	D2
R 1313	CHIPRES.	1k	1/16W	5%	RMC1/16S 102JTH	J24189025		1-	A	D2
R 1314	CHIPRES.	1k	1/16W	5%	RMC1/16S 102JTH	J24189025		1-	A	D2
R 1315	CHIPRES.	1k	1/16W	5%	RMC1/16S 102JTH	J24189025		1-	A	D2
R 1316	CHIPRES.	1k	1/16W	5%	RMC1/16S 102JTH	J24189025		1-	A	D2
R 1317	CHIPRES.	47k	1/16W	5%	RMC1/16S 473JTH	J24189045		1-	B	d2
R 1318	CHIPRES.	1k	1/16W	5%	RMC1/16S 102JTH	J24189025		1-	A	D2
R 1319	CHIPRES.	1k	1/16W	5%	RMC1/16S 102JTH	J24189025		1-	A	D2
R 1320	CHIPRES.	1k	1/16W	5%	RMC1/16S 102JTH	J24189025		1-	A	D1
R 1321	CHIPRES.	100k	1/16W	5%	RMC1/16S 104JTH	J24189049		1-	A	D2
R 1322	CHIPRES.	1k	1/16W	5%	RMC1/16S 102JTH	J24189025		1-	A	D2
R 1323	CHIPRES.	10k	1/16W	0.5%	RR0510P-103-D	J24189143		1-	A	D2
R 1324	CHIPRES.	1k	1/16W	5%	RMC1/16S 102JTH	J24189025		1-	B	d2
R 1325	CHIPRES.	1k	1/16W	5%	RMC1/16S 102JTH	J24189025		1-	A	D2
R 1326	CHIPRES.	1k	1/16W	5%	RMC1/16S 102JTH	J24189025		1-	A	D2
R 1327	CHIPRES.	1k	1/16W	5%	RMC1/16S 102JTH	J24189025		1-	A	D2
R 1328	CHIPRES.	47k	1/16W	5%	RMC1/16S 473JTH	J24189045		1-	A	D2
R 1329	CHIPRES.	47k	1/16W	5%	RMC1/16S 473JTH	J24189045		1-	A	D3
R 1330	CHIPRES.	1k	1/16W	5%	RMC1/16S 102JTH	J24189025		1-	A	D3
R 1331	CHIPRES.	1k	1/16W	5%	RMC1/16S 102JTH	J24189025		1-	A	D3
R 1332	CHIPRES.	1k	1/16W	5%	RMC1/16S 102JTH	J24189025		1-	A	D3
R 1333	CHIPRES.	470	1/16W	5%	RMC1/16S 471JTH	J24189021		1-	B	d2
R 1334	CHIPRES.	1k	1/16W	5%	RMC1/16S 102JTH	J24189025		1-	A	D3
R 1335	CHIPRES.	1k	1/16W	5%	RMC1/16S 102JTH	J24189025		1-	A	D3
R 1336	CHIPRES.	1k	1/16W	5%	RMC1/16S 102JTH	J24189025		1-	A	D3
R 1337	CHIPRES.	1k	1/16W	5%	RMC1/16S 102JTH	J24189025		1-	A	D3
R 1338	CHIPRES.	1k	1/16W	5%	RMC1/16S 102JTH	J24189025		1-	A	D3
R 1339	CHIPRES.	1k	1/16W	5%	RMC1/16S 102JTH	J24189025		1-	A	D3
R 1340	CHIPRES.	1k	1/16W	5%	RMC1/16S 102JTH	J24189025		1-	A	D3
R 1341	CHIPRES.	1k	1/16W	5%	RMC1/16S 102JTH	J24189025		1-	A	D3
R 1342	CHIPRES.	1k	1/16W	5%	RMC1/16S 102JTH	J24189025		1-	A	D3
R 1343	CHIPRES.	1k	1/16W	5%	RMC1/16S 102JTH	J24189025		1-	A	D3
R 1344	CHIPRES.	1k	1/16W	5%	RMC1/16S 102JTH	J24189025		1-	A	D3
R 1345	CHIPRES.	1k	1/16W	5%	RMC1/16S 102JTH	J24189025		1-	A	D3
R 1346	CHIPRES.	1k	1/16W	5%	RMC1/16S 102JTH	J24189025		1-	A	E3
R 1347	CHIPRES.	470	1/16W	5%	RMC1/16S 471JTH	J24189021		1-	A	D3
R 1348	CHIPRES.	1k	1/16W	5%	RMC1/16S 102JTH	J24189025		1-	A	D3
R 1349	CHIPRES.	10	1/16W	5%	RMC1/16S 100JTH	J24189001		1-	A	F2
R 1350	CHIPRES.	10	1/16W	5%	RMC1/16S 100JTH	J24189001		1-	A	F3
R 1351	CHIPRES.	10	1/16W	5%	RMC1/16S 100JTH	J24189001		1-	A	F3
R 1352	CHIPRES.	10	1/16W	5%	RMC1/16S 100JTH	J24189001		1-	A	F3
R 1353	CHIPRES.	10	1/16W	5%	RMC1/16S 100JTH	J24189001		1-	A	F3
R 1354	CHIPRES.	10	1/16W	5%	RMC1/16S 100JTH	J24189001		1-	A	F3
R 1355	CHIPRES.	10	1/16W	5%	RMC1/16S 100JTH	J24189001		1-	A	F3
R 1356	CHIPRES.	10	1/16W	5%	RMC1/16S 100JTH	J24189001		1-	A	F2
R 1357	CHIPRES.	10	1/16W	5%	RMC1/16S 100JTH	J24189001		1-	A	F2
R 1358	CHIPRES.	1M	1/16W	5%	RMC1/16S 105JTH	J24189061		1-	B	g3
R 1359	CHIPRES.	470	1/16W	5%	RMC1/16S 471JTH	J24189021		1-	B	g3
R 1360	CHIPRES.	10k	1/16W	5%	RMC1/16S 103JTH	J24189037		1-	B	g3
R 1361	CHIPRES.	330k	1/16W	5%	RMC1/16S 334JTH	J24189055		1-	B	c3
R 1362	CHIPRES.	0	1/16W	5%	RMC1/16S JPTH	J24189070		1-	B	h3
R 1364	CHIPRES.	10k	1/16W	5%	RMC1/16S 103JTH	J24189037		1-	B	d3
R 1365	CHIPRES.	220	1/16W	5%	RMC1/16S 221JTH	J24189017		1-	A	F2
R 1366	CHIPRES.	0	1/16W	5%	RMC1/16S JPTH	J24189070		1-	B	b2
R 1367	CHIPRES.	4.7k	1/16W	5%	RMC1/16S 472JTH	J24189033		1-	A	G1
R 1368	CHIPRES.	4.7k	1/16W	5%	RMC1/16S 472JTH	J24189033		1-	A	G1
R 1369	CHIPRES.	82k	1/16W	5%	RMC1/16S 823JTH	J24189048		1-	B	b3
R 1370	CHIPRES.	1.5k	1/16W	5%	RMC1/16S 152JTH	J24189027		1-	B	f1
R 1371	CHIPRES.	1k	1/16W	5%	RMC1/16S 102JTH	J24189025		1-	A	E3
R 1372	CHIPRES.	10k	1/16W	5%	RMC1/16S 103JTH	J24189037		1-	A	D3
R 1373	CHIPRES.	4.7k	1/16W	5%	RMC1/16S 472JTH	J24189033		1-	A	G1

MAIN Unit

Parts List

REF	DESCRIPTION	VALUE	V/W	TOL.	MFR'S DESIG	VXSTD P/N	VERS.	LOT	SIDE	LAY ADR
R 1374	CHIPRES.	4.7k	1/16W	5%	RMC1/16S 472JTH	J24189033		1-	A	G1
R 1375	CHIPRES.	0	1/16W	5%	RMC1/16 000JATP	J24185000		4-		
R 1376	CHIPRES.	0	1/16W	5%	RMC1/16 000JATP	J24185000		4-		
R 1377	CHIPRES.	27k	1/16W	5%	RMC1/16S 273JTH	J24189042		7-		
S 1002	ROTARY ENCODER				TP90D281NE20 RY-7815	Q9000835		1-	B	a3
S 1003	TACT SWITCH				SKQTLA	N5090110		1-	B	b1
S 1004	TACT SWITCH				SKQTLA	N5090110		1-	B	c1
TH1001	THERMISTOR				TBPS1R103K440H5Q	G9090067		1-	B	g1
TH1002	THERMISTOR				TBPS1R104K475H5Q	G9090069		1-	B	h2
TH1003	THERMISTOR				TBPS1R473K475H5Q	G9090068		1-	A	E1
X 1001	XTAL TRS-4.0	4MHz			4.000MHZ	H0103283		1-	B	d2
X 1001	XTL XJNGGIDANF	4MHz			4.000000MHz	H0103314		10-	B	d2
X 1002	XR0021250000T0051123	21.25MHz			21.25MHZ	H0103303		1-	B	g1
XF1001	XTAL FILTER				UM-5-3P 21R15AB	H1102374		1-	B	e1
XF1001	XTAL FILTER				UM-5-3P 21R15AB	H1102428		28-	B	e1
XF1002	XTAL FILTER				UM-5-3P 21R15AB	H1102374		1-	B	e1
XF1002	XTAL FILTER				UM-5-3P 21R15AB	H1102428		28-	B	e1
	REFLECTORSHEET				(A)	RA0580500		1-		
	INTERCONNECTOR				(LCD)	RA0580700		1-		
	MIC HOLDER RUBBER					RA0578200		1-		
	TERMINAL PLATE					RA0698700		1-		
	LIGHT GUIDE				(LCD)	RA1136800		1-		
	LIGHT GUIDE				(LCD)	RA113680A		62-		

FTD-7 DTMF Paging Unit (Option)

Circuit Diagram

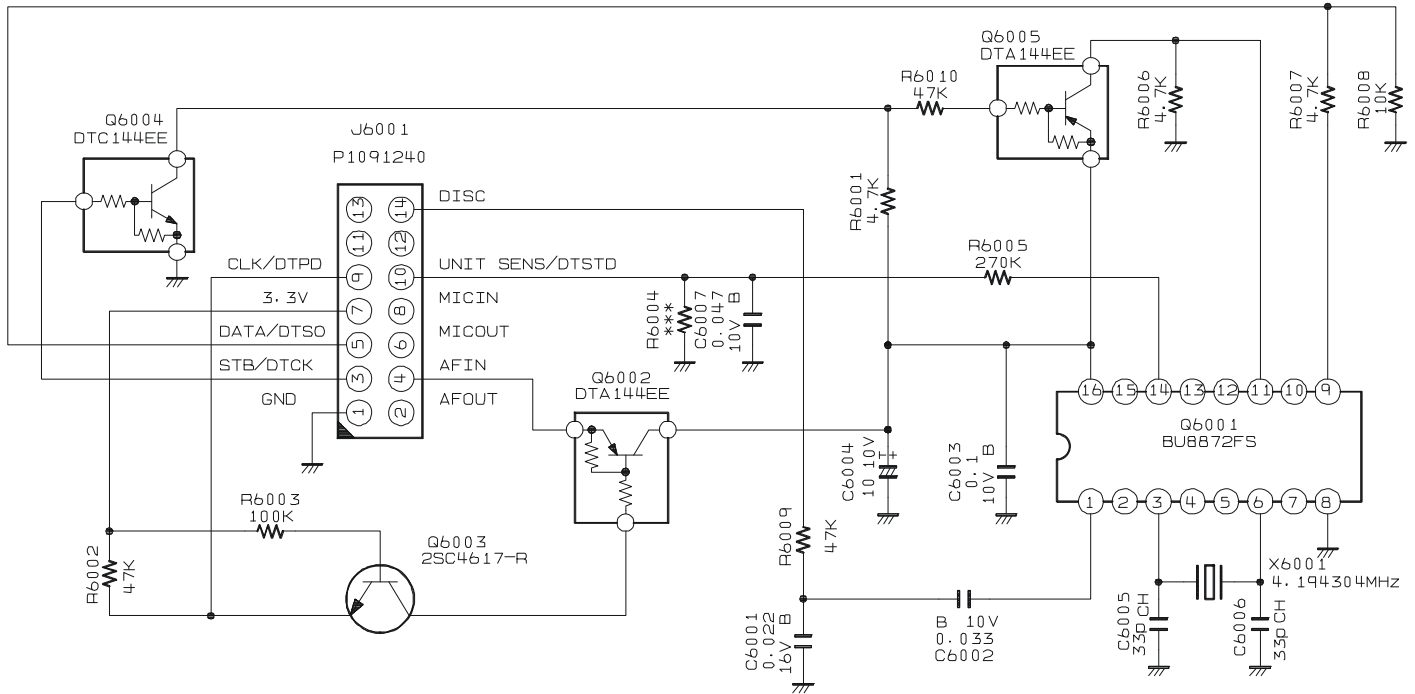

Parts Layout

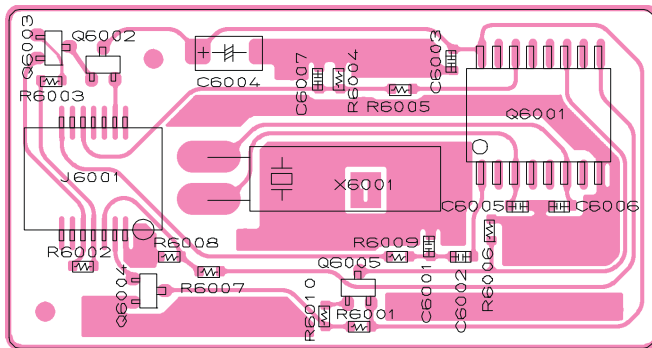

(Side A)



(Side B)

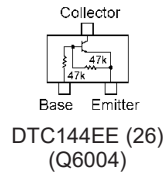
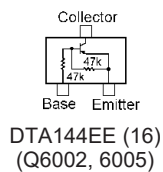
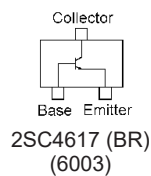
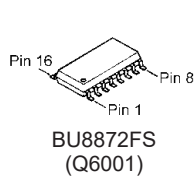

FTD-7 DTMF Paging Unit (Option)

Parts List

REF	DESCRIPTION	VALUE	V/W	TOL.	MFR'S DESIG	VXSTD P/N	VERS.	LOT	SIDE	LAY ADR
	Printed Circuit Board				AAE33X000	FR0133600		1-		
C 6001	CHIP CAP.	0.022uF	16V	B	GRM36B223K16PT	K22128806		1-		
C 6002	CHIP CAP.	0.033uF	10V	B	GRM36B333K10PT	K22108803		1-		
C 6003	CHIP CAP.	0.1uF	10V	B	GRM36B104K10PT	K22108802		1-		
C 6004	CHIP TA.CAP.	10uF	10V		TEMSVA1A106M-8R	K78100028		1-		
C 6005	CHIP CAP.	33pF	50V	CH	GRM1552C1H330JZ01D	K22178224		1-		
C 6006	CHIP CAP.	33pF	50V	CH	GRM1552C1H330JZ01D	K22178224		1-		
C 6007	CHIP CAP.	0.047uF	10V	B	GRM36B473K10PT	K22108801		1-		
J 6001	CONNECTOR				AXK5F14545YJ	P1091240		1-		
Q 6001	IC				BU8872FS-E2	G1093656		1-		
Q 6002	TRANSISTOR				DTA144EE TL	G3070074		1-		
Q 6003	TRANSISTOR				2SC4617 TL R	G3346178R		1-		
Q 6004	TRANSISTOR				DTC144EE TL	G3070075		1-		
Q 6005	TRANSISTOR				DTA144EE TL	G3070074		1-		
R 6001	CHIP RES.	4.7k	1/16W	5%	RMC1/16S 472JTH	J24189033		1-		
R 6002	CHIP RES.	47k	1/16W	5%	RMC1/16S 473JTH	J24189045		1-		
R 6003	CHIP RES.	100k	1/16W	5%	RMC1/16S 104JTH	J24189049		1-		
R 6005	CHIP RES.	270k	1/16W	5%	RMC1/16S 274JTH	J24189054		1-		
R 6006	CHIP RES.	4.7k	1/16W	5%	RMC1/16S 472JTH	J24189033		1-		
R 6007	CHIP RES.	4.7k	1/16W	5%	RMC1/16S 472JTH	J24189033		1-		
R 6008	CHIP RES.	10k	1/16W	5%	RMC1/16S 103JTH	J24189037		1-		
R 6009	CHIP RES.	47k	1/16W	5%	RMC1/16S 473JTH	J24189045		1-		
R 6010	CHIP RES.	47k	1/16W	5%	RMC1/16S 473JTH	J24189045		1-		
X 6001	XTAL CSA-309	4.194304MHz			4.194304MHZ	H0102987		1-		



Copyright 2010
VERTEX STANDARD CO., LTD.
All rights reserved

No portion of this manual
may be reproduced without
the permission of
VERTEX STANDARD CO., LTD.