

VHF/UHF DUAL BAND FM TRANSCEIVER

FT-4XR/FT-4XE

VHF FM Transceiver

FT-4VR/FT-4VE

EH069M90A

©2018 YAESU MUSEN CO., LTD.

Introduction

This manual provides the technical information necessary for servicing the FT-4XR/FT-4XE and FT-4VR/FT-4VE Transceiver. Servicing this equipment requires expertise in handling surface-mount chip components. Attempts by non-qualified persons to service this equipment may result in permanent damage not covered by the warranty, and may be illegal in some countries. While we believe the information in this manual to be correct, YAESU assumes no liability for damage that may occur as a result of typographical or other errors that may be present. Your cooperation in pointing out any inconsistencies in the technical information would be appreciated.

Contents

Specifications
Exploded View & Miscellaneous Parts
Block Diagram
Board Unit (Schematics & Layouts)
MAIN Unit

Caution

Risk of explosion if battery is replaced by an incorrect type. Dispose of used batteries according to the instructions.

Important Note

This transceiver was assembled using Pb (lead) free solder, based on the RoHS specification. Only lead-free solder (Alloy Composition: Sn-3.0Ag-0.5Cu) should be used for repairs performed on this apparatus. The solder stated above utilizes the alloy composition required for compliance with the lead-free specification, and any solder with the above alloy composition may be used.

General

Frequency Range:	FT-4XR/FT-4XE	RX: 136 MHz - 174 MHz 400 MHz - 480 MHz 65 MHz - 108 MHz (FM Broadcast)	TX: 136 MHz - 174 MHz (Asian version) 144 MHz - 146 MHz (European version) 144 MHz - 148 MHz (USA version) 400 MHz - 480 MHz (Asian version) 430 MHz - 440 MHz (European version) 430 MHz - 450 MHz (USA version)
	FT-4VR/FT-4VE	RX: 136 MHz - 174 MHz 65 MHz - 108 MHz (FM Broadcast)	TX: 136 MHz - 174 MHz (Asian version) 144 MHz - 146 MHz (European version) 144 MHz - 148 MHz (USA version)
Channel Steps:	5/10/12.5/15/20/25/50/100 kHz		
Mode of Emission:	F2D, F3E, F2A		
Frequency Stability:	±2.5 ppm (−4 °F to +140 °F [−20 °C to +60 °C])		
Antenna Impedance:	50 ohms		
Supply Voltage:	Nominal. 7.4 V DC, Negative Ground SBR-28LI		
Current Consumption (Approx.):	190 mA (Receive, 200 mW Audio Output) 95 mA (Standby, Saver OFF) 23 mA (Standby, Saver ON) 5 mA (Auto Power OFF) 1.5 A (5 W TX, 144 MHz) 7.4 V DC 1.7 A (5 W TX, 430 MHz) 7.4 V DC (FT-4XR/FT-4XE)		
Operating Temperature:	−4 °F to +140 °F (−20 °C to +60 °C)		
Case Size (W x H x D):	2.0" x 3.5" x 1.2" (52 mm x 90 mm x 30 mm) (w/o knob and antenna)		
Weight (Approx.):	8.82 oz (250 g) (with SBR-28LI and antenna)		

Transmitter

RF Power Output:	5 W (High) / 2.5 W (Middle) / 0.5 W (Low) (@ 7.4 V with SBR-28LI)
Modulation Type:	Variable Reactance
Maximum Deviation:	±5 kHz
Spurious Emission:	At least 60 dB below (@ TX Power High, Middle) At least 50 dB below (@ TX Power Low) (USA/Asian version) At least 55 dB below (@ TX Power Low) (European version)
Microphone Impedance (Approx.):	2 kohm

Receiver

Circuit Type:	Direct-conversion
Sensitivity:	0.2 µV for 12 dB SINAD (140 - 150 MHz, NFM) 0.2 µV for 12 dB SINAD (420 - 470 MHz, NFM) (FT-4XR/FT-4XE)
Selectivity (−6 dB / −60 dB):	FM, NFM ±25 kHz / 12.5 kHz
AF Output:	800 mW (16 Ω for THD 10 % 7.4 V DC) internal speaker 800 mW (16 Ω for THD 10 % 7.4 V DC) external speaker

Specifications are subject to change without notice, and are guaranteed within the 144 MHz amateur bands only. Frequency ranges will vary according to transceiver version; check with your dealer.

Symbol Placed On The Equipment

 Direct current

SP/MIC CAP AH066
S8003350

VOL NUT AH066
S8003368

VOL KNOB AH066
S8003364

ANTENNA NUT AH066
S8003366

JACK COVER AH069
S8003428

O-RING-2 AH066
S8003358

O-RING-1 AH066
S8003356

TERMINAL HOLDER AH069
S8003426

CHASSIS ASSY AH069
S8003430

Aluminum die-cast chassis
Rear plate
LATCH KIT AH066

FRONT PANEL ASSY
FT-4X (S8003416)
FT-4V (S8003418)

Speaker with wire
PTT/MON/Function rubber
Window with double face
Top LED light guide
Top button (orange)
Sponge for windows
Product name label

KEY PAD
FT-4X (S8003422)
FT-4V (S8003424)

LCD ASSY AH069
S8102444

LCD module
LCD holder
Light guide (including reflector seat)
Interconnector

MAIN BOARD ASSY
FT-4X A2 version (S8102452)
FT-4X B2 version (S8102454)
FT-4X B3 version (S8102446)
FT-4V A2 version (S8102456)
FT-4V B2 version (S8102458)
FT-4V B3 version (S8102448)

Antnna jack SMA
VOL
O-RING-1 AH066
O-RING-2 AH066
Mic cap

LATCH KIT AH066
S8003360

Countersunk screw 3pcs
Coil spring
Latch nail
Hold plate

Serial Number

Please provide the serial number of the transceiver when ordering a FT-4X/FT-4V MAIN BOARD ASEMBLY.
The serial number is located in the battery compartment of the transceiver.

FT-4XR
YAESU MUSEN CO., LTD. MADE IN CHINA

XXXXXXXXXXXXXX

SER. NO. 12345678

About MAIN BOARD ASSY

The MAIN BOARD ASSY has been carefully assembled and aligned at the factory. If a component part fails, the MAIN BOARD ASSY is replaced as a complete unit.
Attempting replacement or repair of components on the MAIN BOARD ASSY is not recommended.

REF	YAESU P/N	Description	Qty.
①	SCREW KIT AH069 S8003432	Countersunk screw	2
②		Round head screw	7
③		Special screw	2
④	BELT CLIP SCREW S8003376	Belt clip screw	2

Non-designated parts are available only as part of a designated assembly.

Block Diagram FT-4XR / FT-4XE

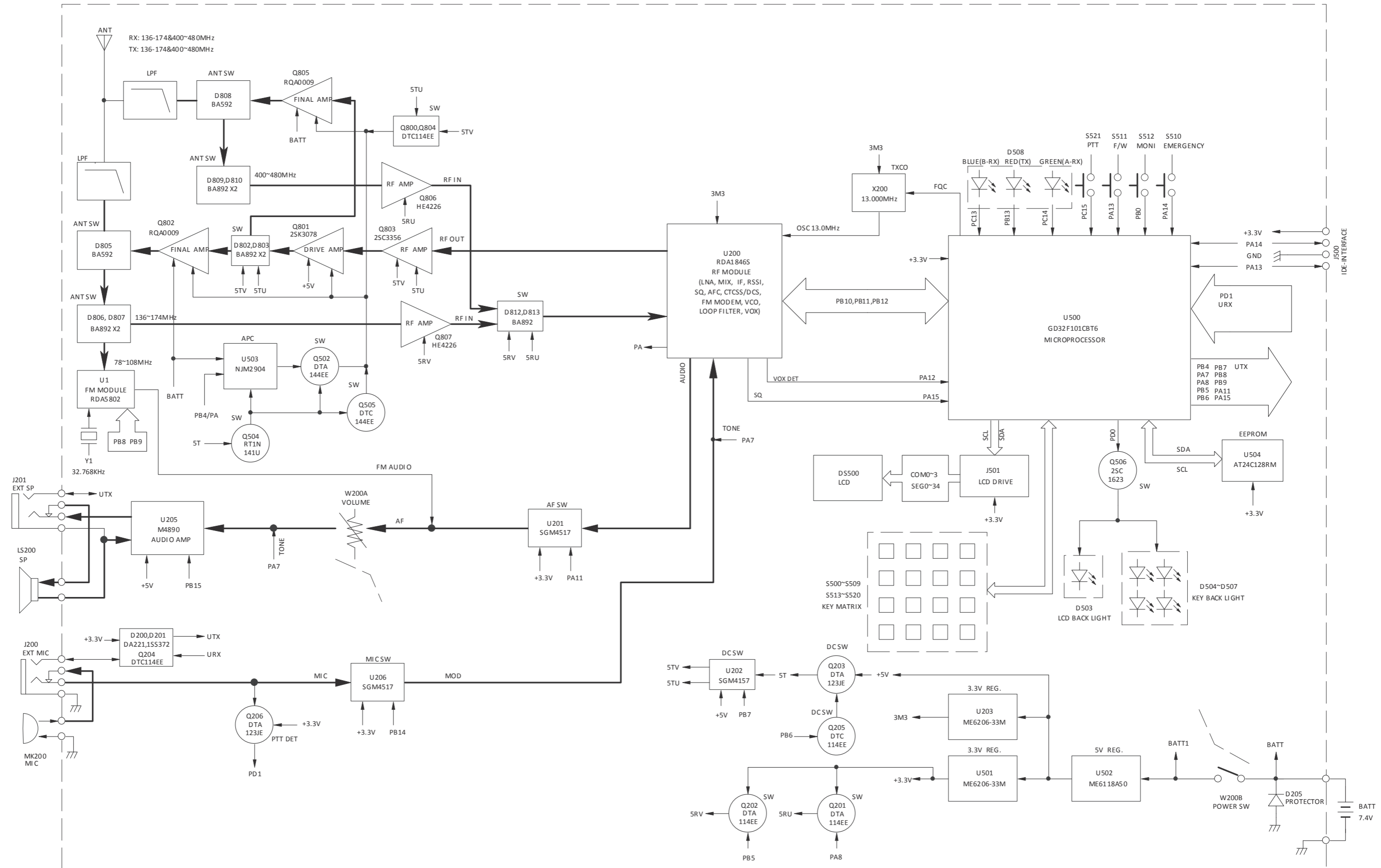

Block Diagram - 2

Block Diagram FT-4VR / FT-4VE

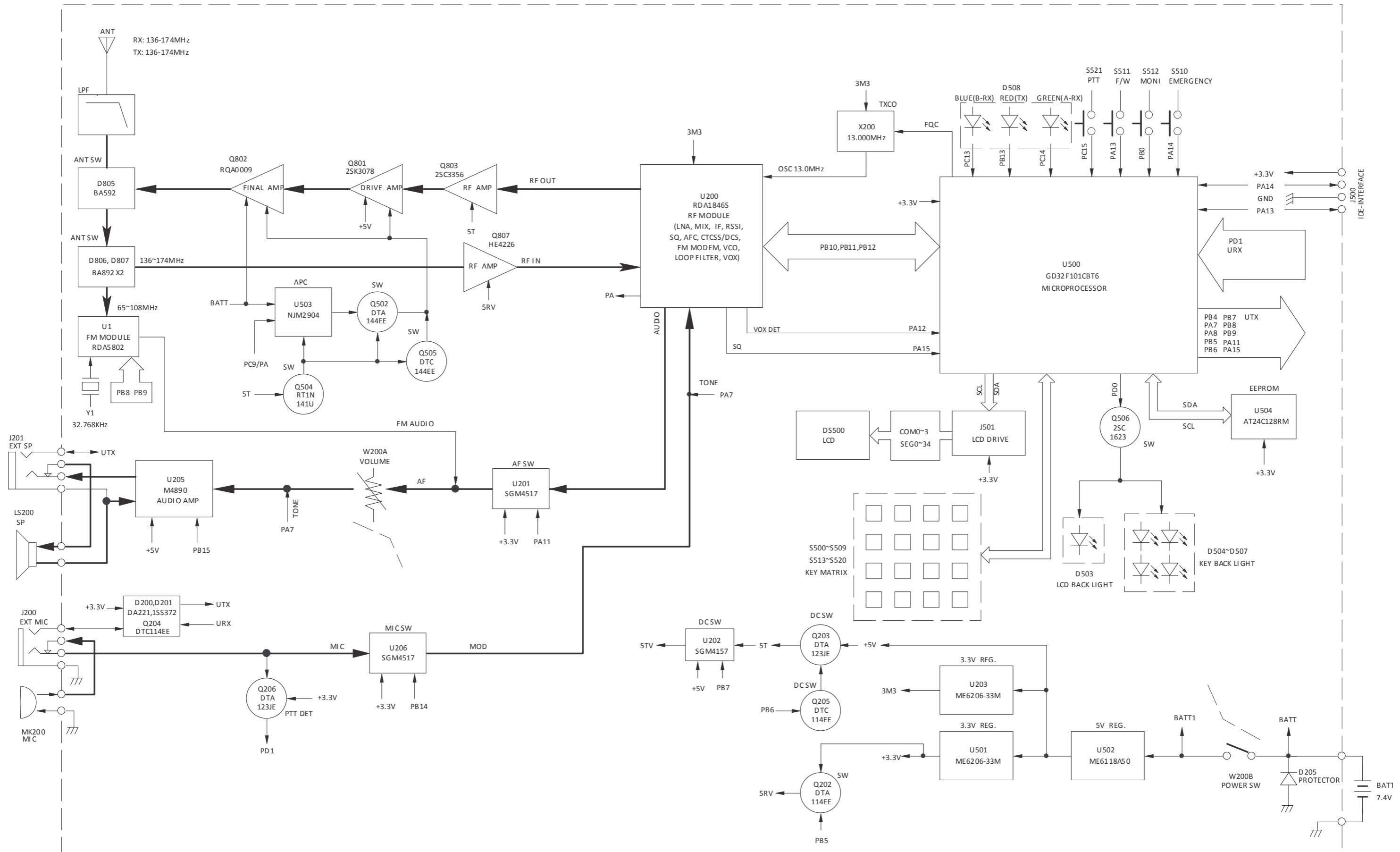

Block Diagram - 3

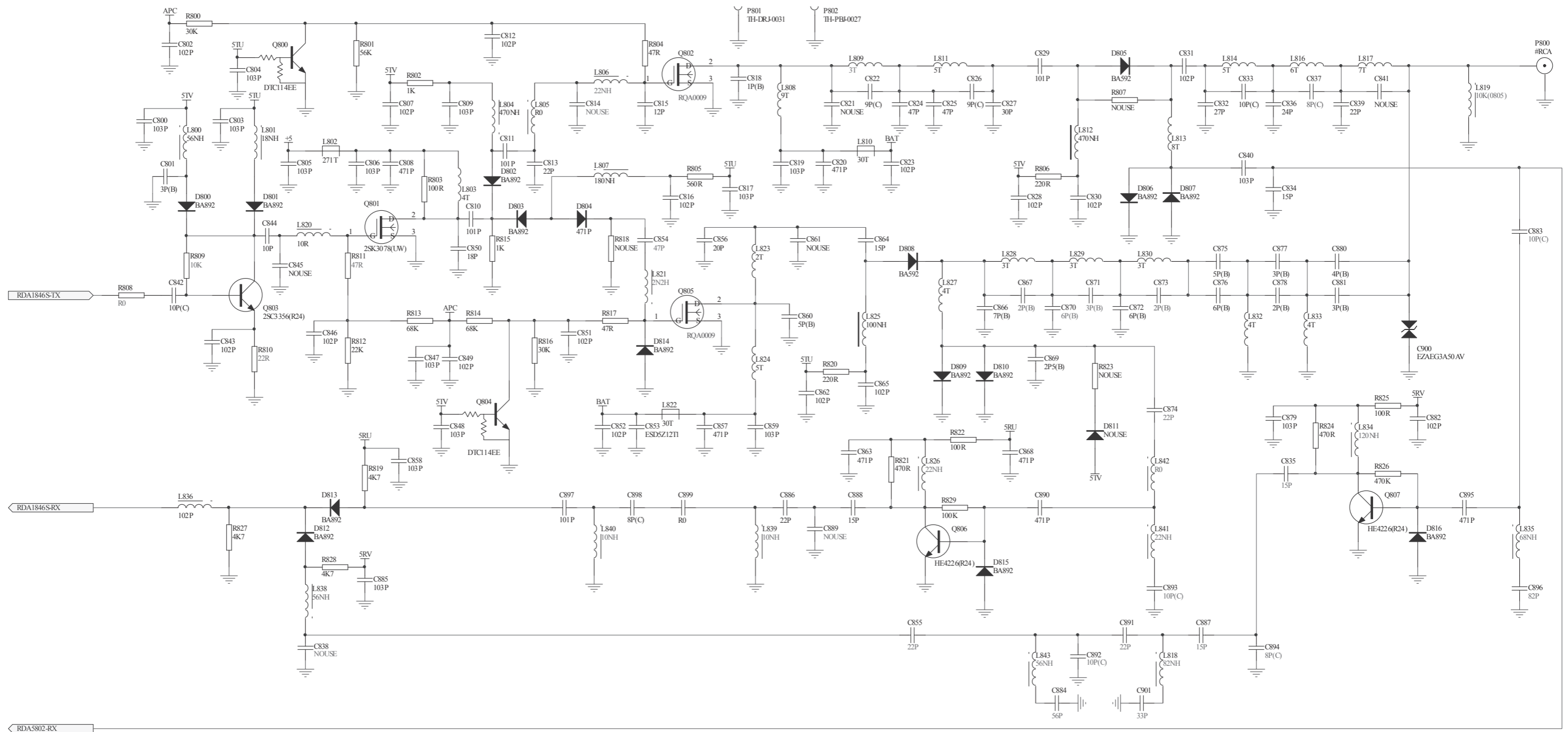

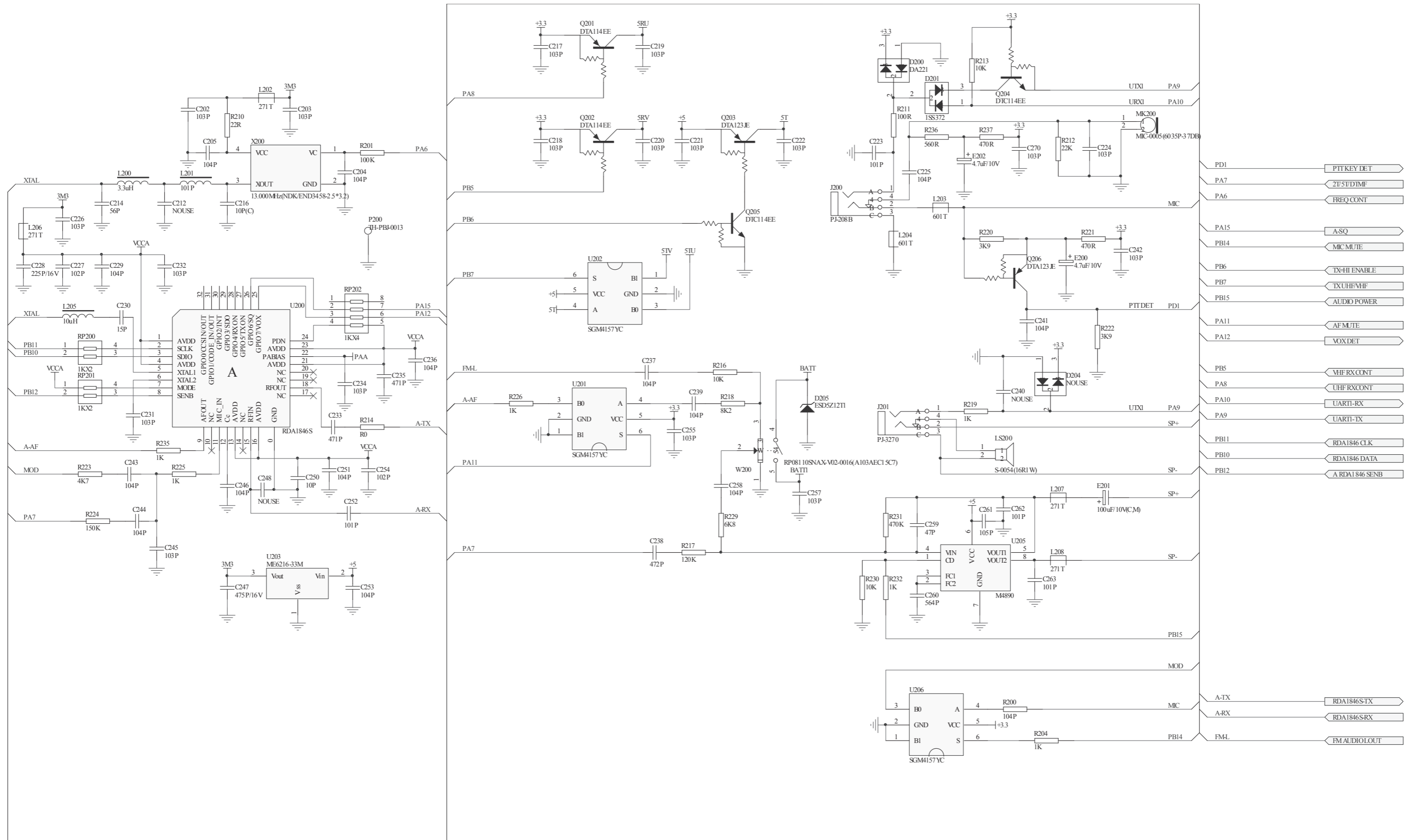

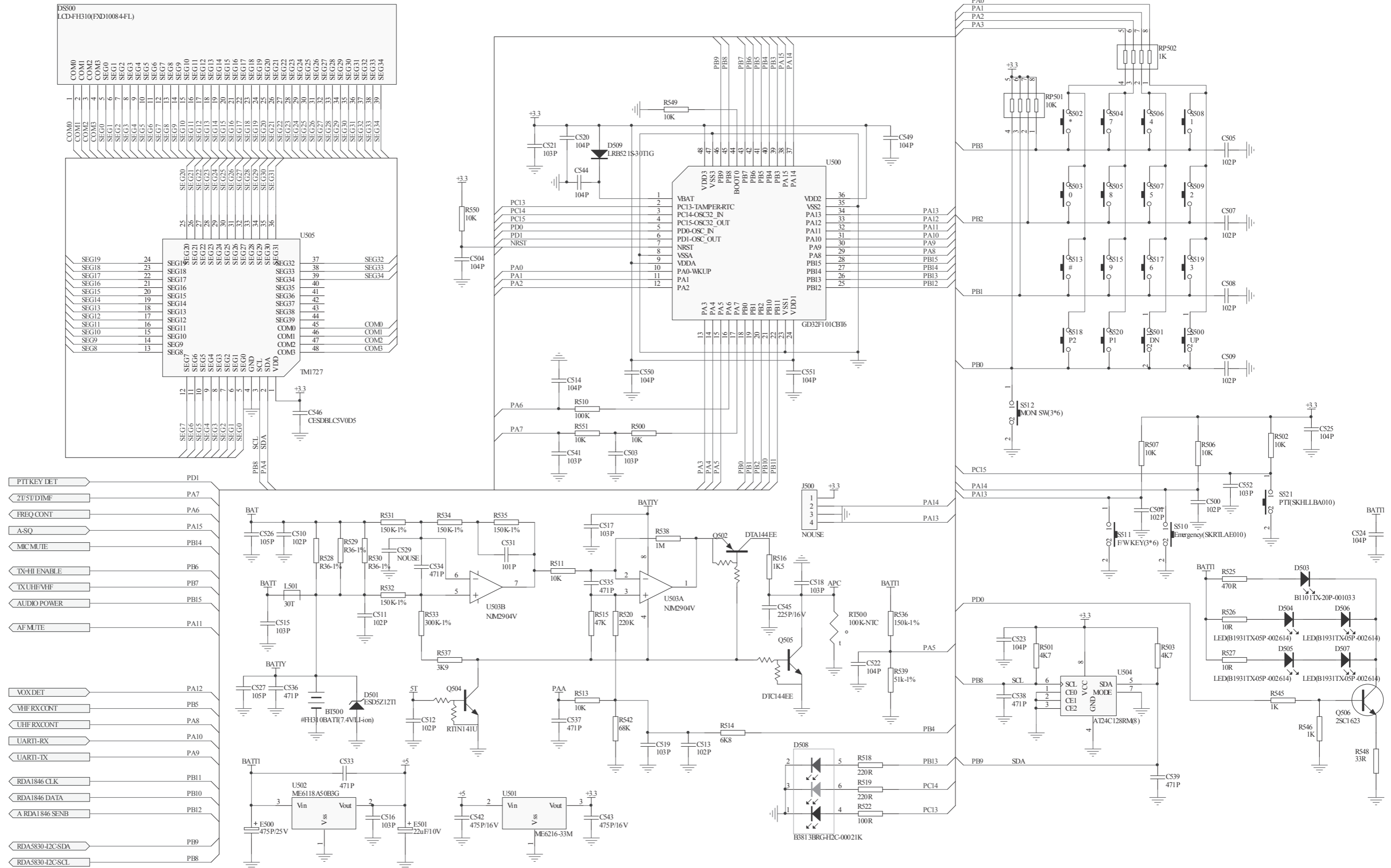

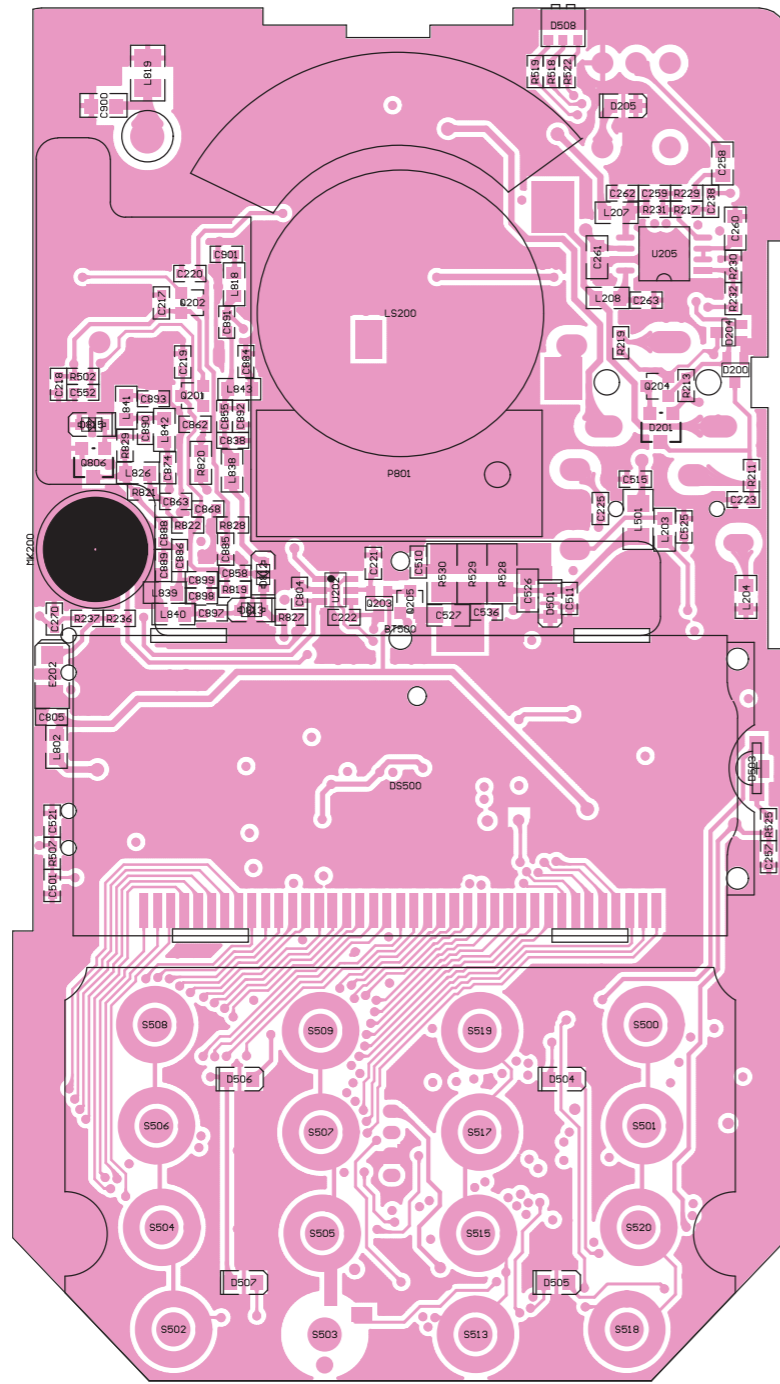

Side A

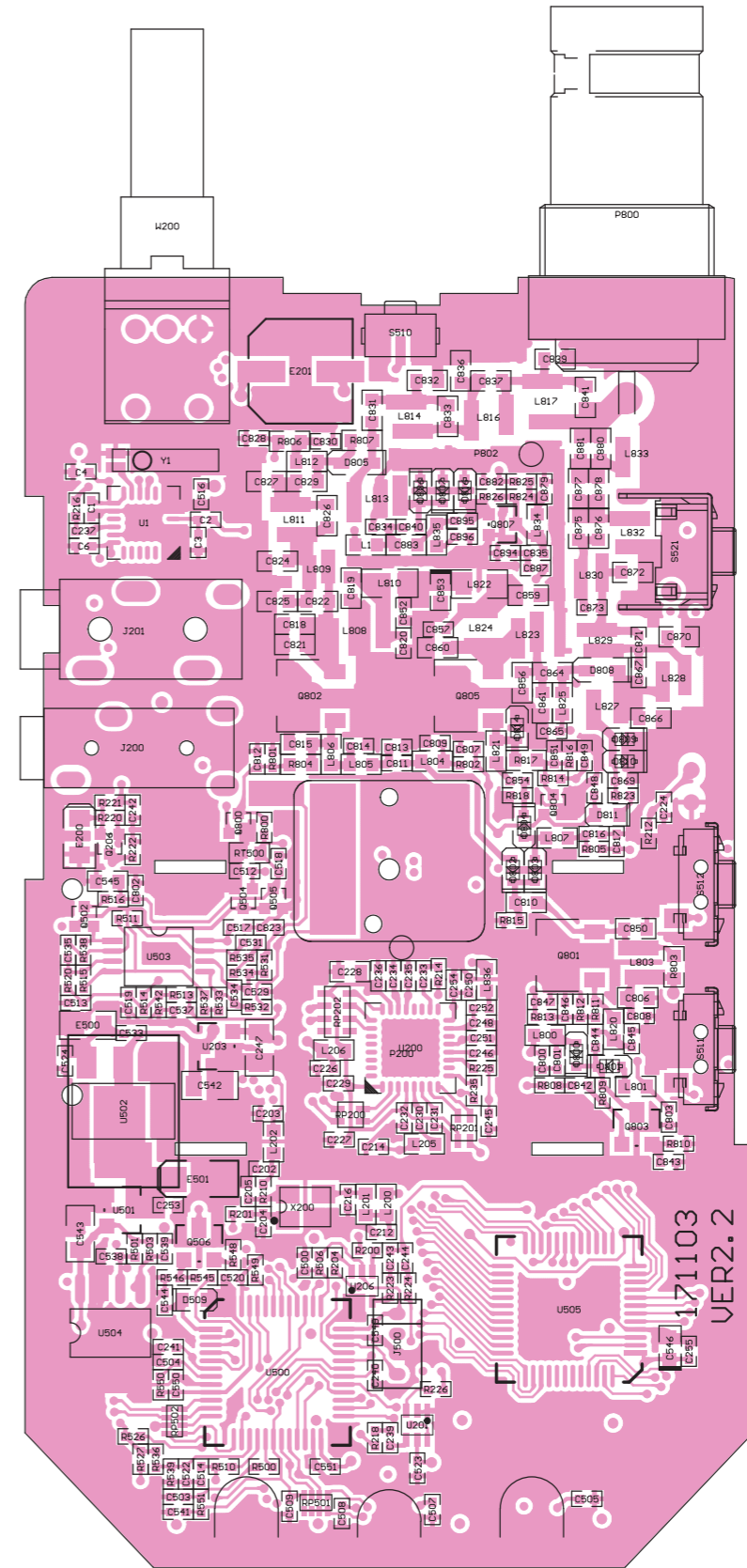

Side B

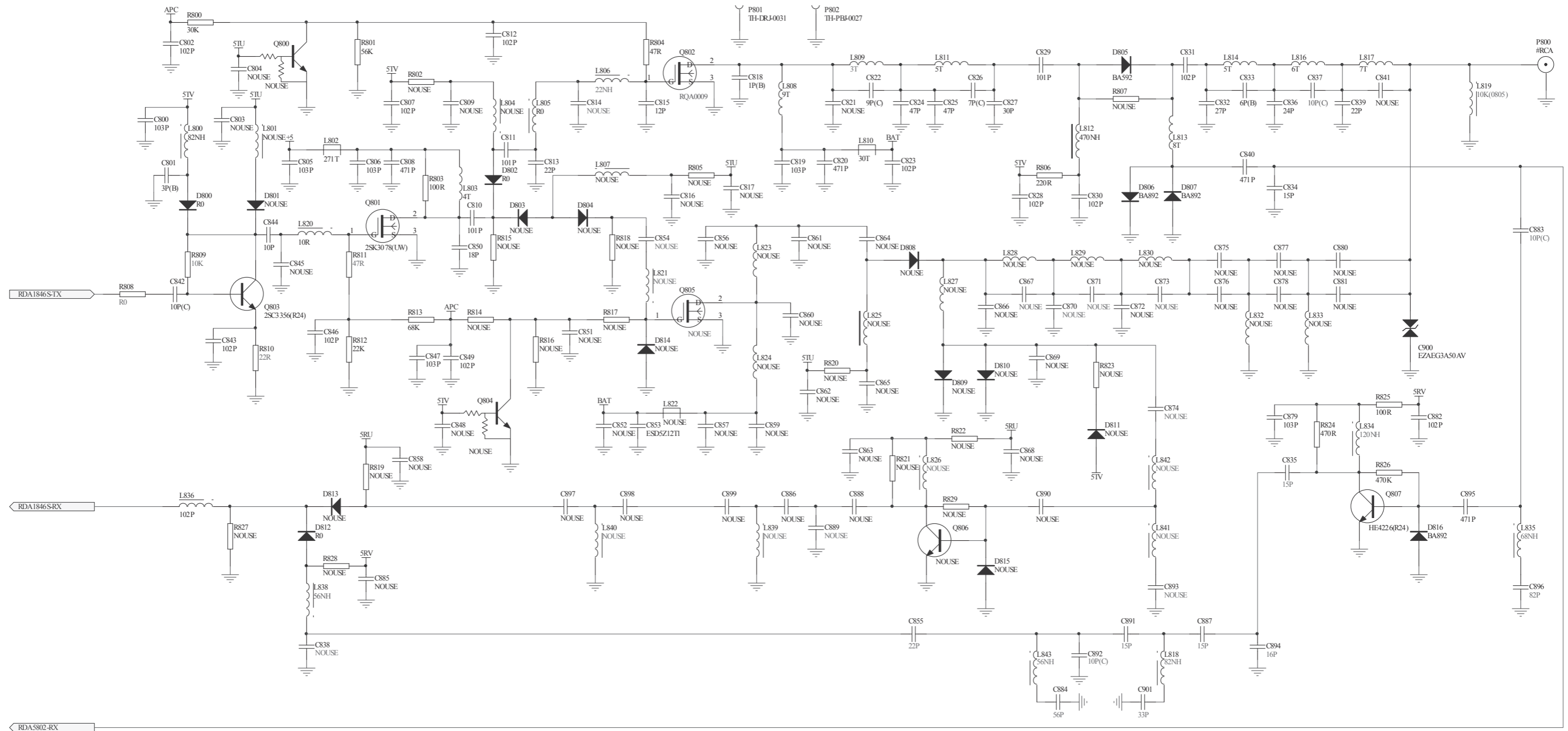

MAIN Unit (FT-4VR / FT-4VE)

Circuit Diagram (2/4)

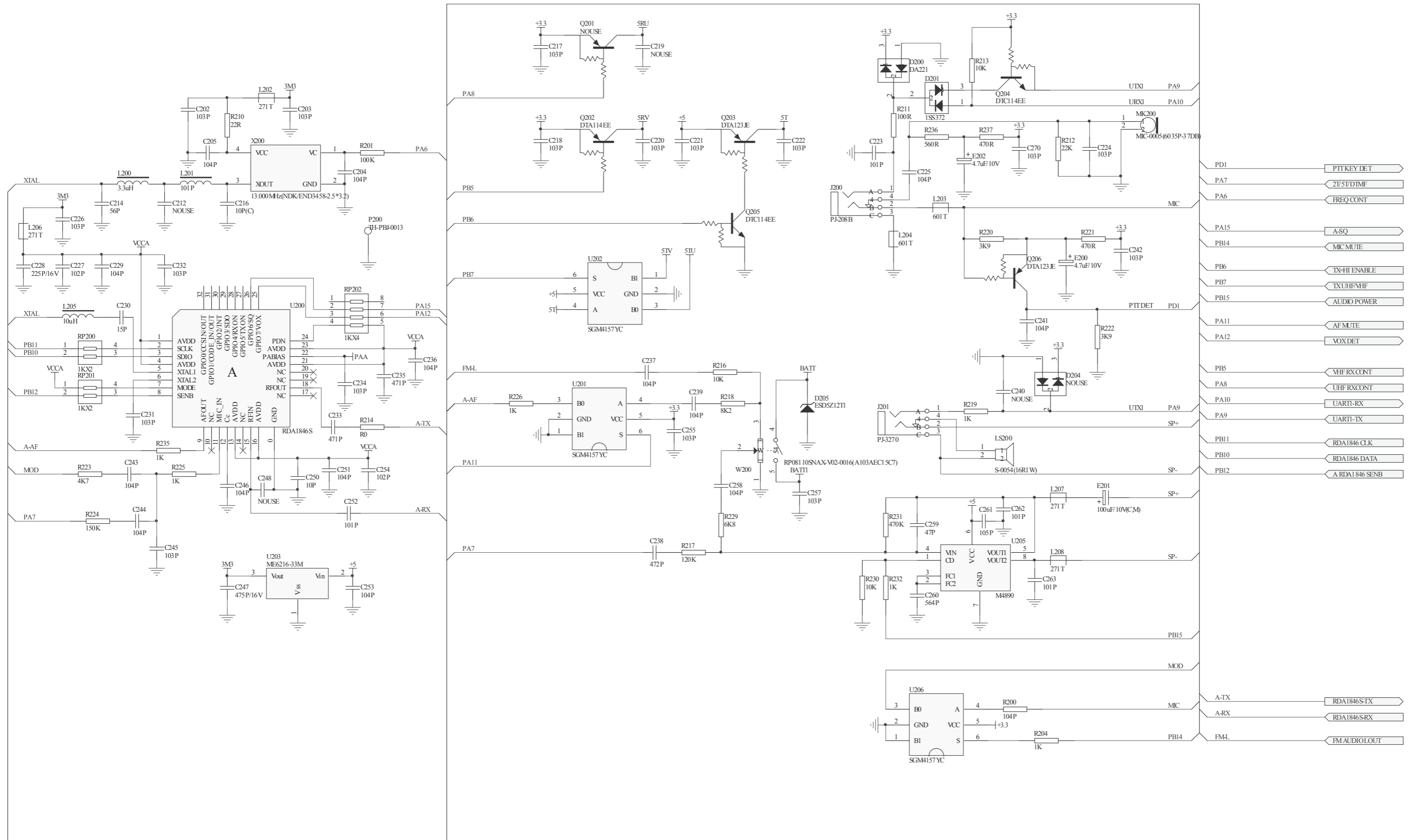

MAIN Unit (FT-4VR / FT-4VE)

Circuit Diagram (3/4)

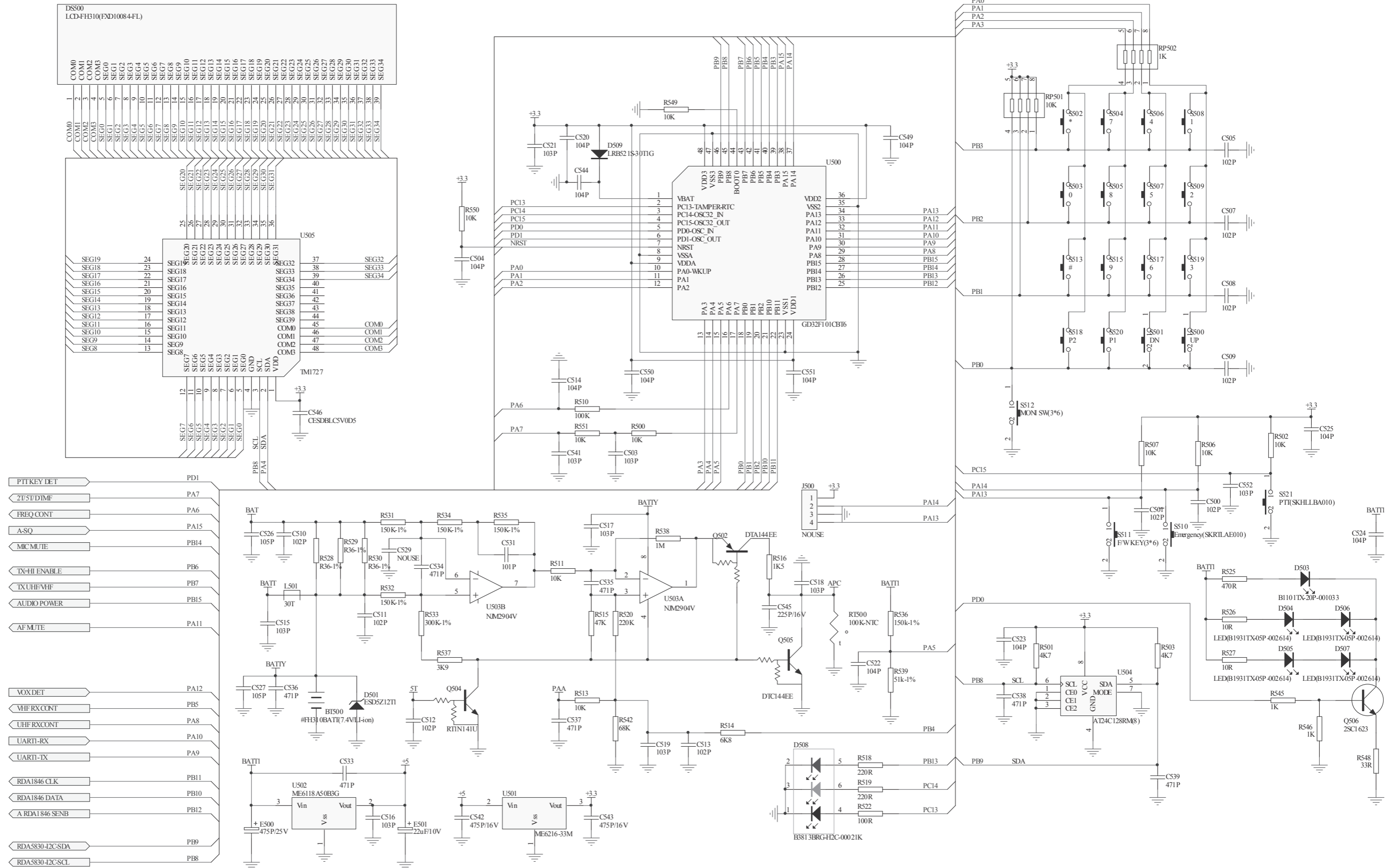

MAIN Unit (FT-4VR / FT-4VE)

Circuit Diagram (4/4)

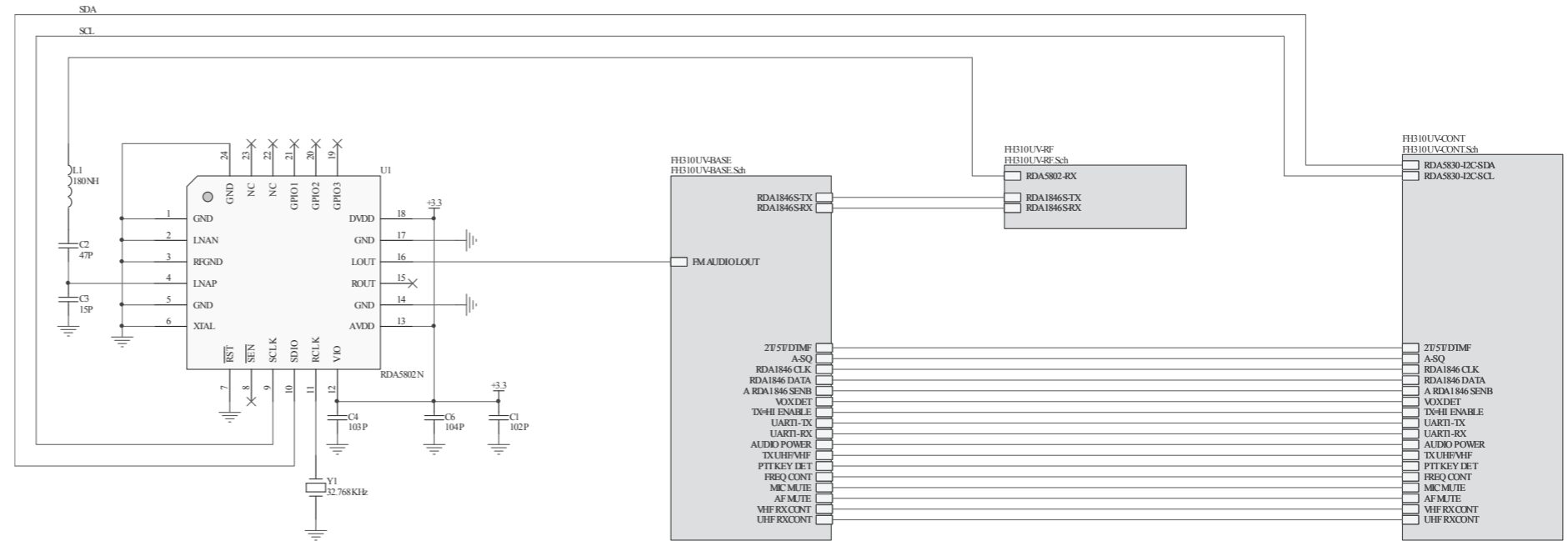

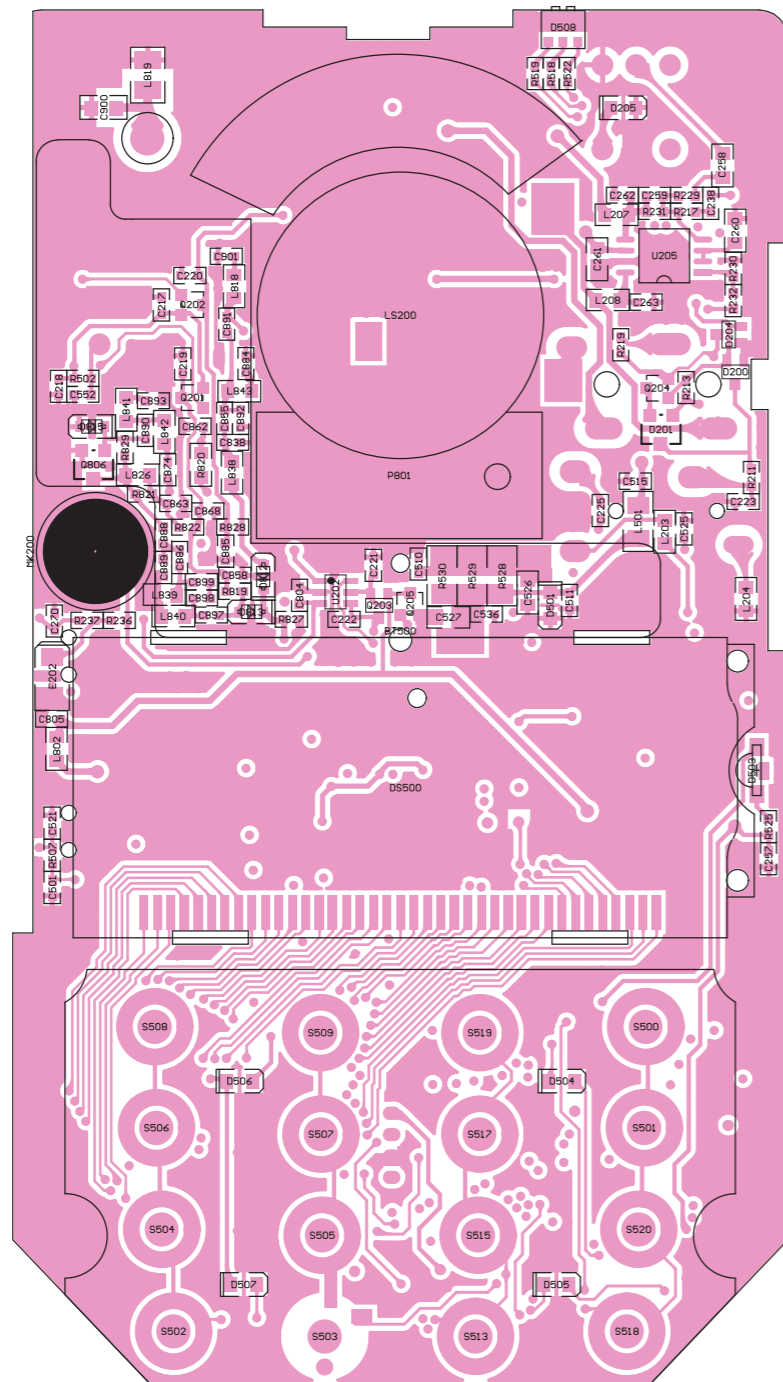

Side A

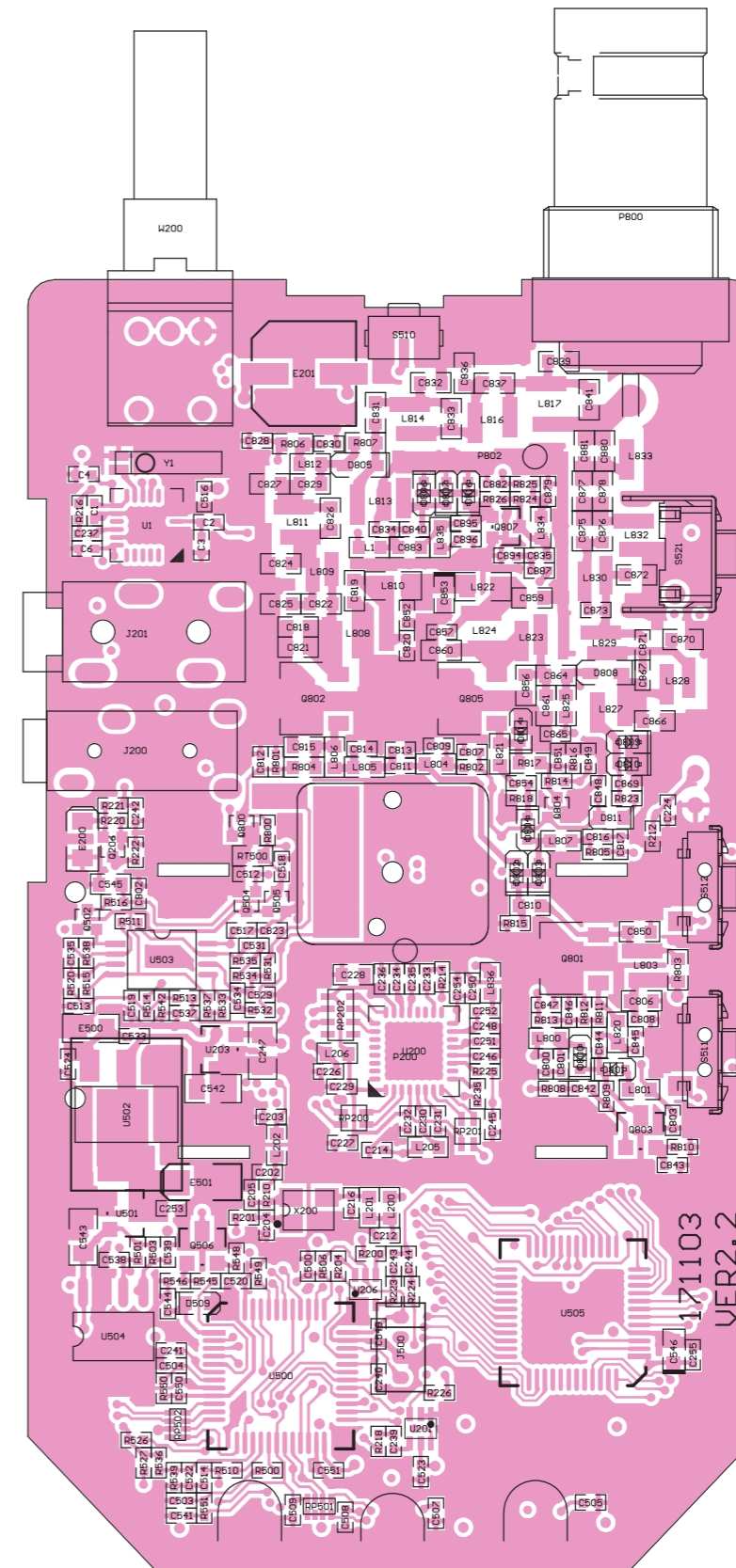

Side B



Copyright 2018
YAESU MUSEN CO., LTD.
All rights reserved.

No portion of this manual may be
reproduced without the permission of
YAESU MUSEN CO., LTD.

YAESU MUSEN CO., LTD.

Tennozu Parkside Building
2-5-8 Higashi-Shinagawa, Shinagawa-ku, Tokyo 140-0002 Japan

YAESU USA

6125 Phyllis Drive, Cypress, CA 90630, U.S.A.

YAESU UK

Unit 12, Sun Valley Business Park, Winnall Close
Winchester, Hampshire, SO23 0LB, U.K.