

# **FT-703R INSTRUCTION MANUAL**



**YAESU MUSEN CO., LTD.  
C.P.O. BOX 1500  
TOKYO, JAPAN**

# INDEX

GENERAL .....	1
SPECIFICATIONS .....	2
SEMICONDUCTORS .....	3
SUPPLIED ACCESSORIES AND OPTIONS .....	3
CONTROLS AND CONNECTIONS .....	4
ANTENNA CONSIDERATIONS .....	9
BATTERY INFORMATION .....	10
BATTERY CHARGER INFORMATION .....	12
YH-2 HEADSET AND MH-12 <sub>A2B</sub> SPEAKER/MIC .....	16
OPERATION .....	16
FTS-7 TONE SQUELCH	
INSTALLATION AND PROGRAMMING .....	18
BLOCK DIAGRAM .....	21

# FT-703R

## 0.7-METER BAND FM HAND-HELD TRANSCEIVER

### GENERAL

The FT-703R is a compact UHF FM hand-held transceiver that offers a combination of features and convenience never before available in such a small, lightweight unit. The small size is made possible by extensive use of address chip components on double-sided composite glass-epoxy/phenol circuit boards. Reliability is guaranteed by computer-aided design and totally automatic computer-controlled circuit board assembly.

Three-digit thumbwheel frequency selection switches assure simple operation, with simplex or standard\* repeater shifts selectable on the rear panel. A BNC-type antenna jack is provided for the supplied rubber flex antenna, or easy connection of another antenna of your choice, while the top panel illuminated S-meter provides indication of relative signal strength on receive and relative power output on transmit. High or low RF power output (2.5W or 0.3W) and 5 kHz frequency offset are selectable via top panel switches.

When used with the optional external YH-2 Headset, the VOX system in the transceiver provides voice-actuated transmit/receive switching, allowing the operator to have both hands complete free during QSOs while the transceiver hangs on the belt or in the optional MMB-21 Mobile Hanger Bracket. The optional MH-12 A2B Speaker/Mic is also available to add to the performance and convenience of the FT-703R.

European versions come equipped with the FTE-2 1750 Hz Tone Burst Generator, while for other versions the FTS-7 37-tone Programmable CTCSS Tone Squelch Unit is available as an option, providing tone-squelched reception and a user-programmable subaudible tone on transmission when desired. All versions include "on air" and "busy" LEDs to indicate transmitter activation and occupied frequencies.

- \* Models A & X    ±5 MHz
- Model B        -7.6 MHz
- Model C        +1.6 MHz

Power source options include the FNB-3 (10.8V 425 mAh) and FNB-4 (12V 500 mAh) Ni-Cd battery pack or the FBA-5 battery case for six AA-size dry cells. Chargers available include the NC-9B/C (for FNB-3) and NC-18B/C (for FNB-4) 15-hour wall charger, NC-15 Quick charger/Adapter and the PA-3 DC-DC mobile adapter.

Please read this manual carefully so as to become acquainted with the convenient features of the FT-703R.

## SPECIFICATIONS

### GENERAL

**Freq. range:**  
 440–450 or 430–440 MHz (per local requirements)  
**Channel steps:**  
 10 kHz, and +5 kHz switch  
**Mode:**  
 F3 (G3E)  
**Antenna:**  
 BNC connector, rubber flex antenna supplied  
**Supply voltage:**  
 5.5–13V DC  
**Current:**  
 RX 100 mA; Standby 25 mA;  
 TX 800 mA (@ 10.8V, 2.5W RF)  
**Case size:**  
 65 (W) x 34 (D) x 153 (H) mm  
**Weight:**  
 Approx. 530g w/FNB-3

**Audio output:**  
 500 mW into 8 ohms for 5% THD, or better

### TRANSMITTER (@ 10.8V)

**Input power:**  
 6W DC for 2.5W RF output into 50 ohms  
**Modulation:**  
 Variable reactance  
**Deviation:**  
 ±5 kHz  
**Max. bandwidth:**  
 16 kHz  
**Microphone:**  
 Internal or optional external condenser, 2 kilohms

Specification subject to change without notice or obligation

### RECEIVER (@ 10.8V)

**Circuit type:**  
 Double conversion superheterodyne  
**First IF:**  
 21.6 MHz  
**Second IF:**  
 455 kHz  
**Sensitivity:**  
 0.25  $\mu$ V for 12 dB SINAD,  
 1  $\mu$ V for 30 dB S/N  
**Selectivity:**  
 12 kHz/–6 dB, 24 kHz/–60 dB

### MODEL CHART\*

Model	A	B	C	X
Frequency (MHz)	440–450	430–440	430–440	430–440
Tone Burst	not available	1750 Hz	1750 Hz	not available
Repeater Shift	±5 MHz	–7.6 MHz	+1.6 MHz	±5 MHz
Tone Squelch	option	not available	not available	option

\* DTMF keypad available as an option for all models.

# SEMICONDUCTORS

ICs:		TRANSISTORS:		DIODES:		
LA4145	1	2SA1162GR(SG)	8	Si	1S1555	1
LA6324M	1	2SB793R	2		1SS184(B3)	4
TC5081AP	1	2SC458B	1		1SS205	13
TC5082PL	1	2SC2026	2		1SS224(C1)	1
TC9122P	1	2SC2407	1		1SS226(C3)	1
TK10420	1	2SC2620B(QB)	4	Schottky	1SS106	2
		2SC2712GR(LG)	11	Varactor	1T25	1
ETs:		2SC2759(U22)	1	Zener	HZ6A1L	1
2SK2080(JO)	1	2SC3019	1		HZ9B2L	1
2SK210Y(YY)	1	2SC3101	1	LED	LN38GCP	1
2SK242(T3)	1	2SC3120(HB)	1		LN28RCP	1
		2SC3356(T2B)	1			

## SUPPLIED ACCESSORIES

<b>FNB-3</b>
10.8V, 425 mAh Ni-Cd pack
<b>CSC-6</b>
Soft Case
<b>FTE-2 (European models only)</b>
1750 Hz Tone Burst Unit
<b>YHA-44A</b>
Rubber Flex Antenna

## OPTIONS

<b>FNB-4</b>
12V 500 mAh Ni-Cd pack
<b>FBA-5</b>
Battery Case for 6 AA-size dry cells
<b>YH-2</b>
Headset
<b>MH-12A2B</b>
Speaker/Microphone
<b>FTS-7 (for Models A &amp; X only)</b>
Programmable Tone Squelch
<b>PA-3</b>
DC Car Adapter/Trickle Charger
<b>MMB-21</b>
Mobile Hanger Bracket
<b>NC-9B* NC-18B**</b>
Compact Charger 117 VAC
<b>NC-9C* NC-18C**</b>
Compact Charger 220 VAC
<b>NC-15</b>
Quick Charger/DC Adapter

Note: Certain items may or may not be included as standard or as options according to local needs and popularity.

\* for FNB-3 only

\*\* for FNB-4 only

# CONTROLS AND CONNECTIONS

## ① Antenna Jack

This BNC-type jack accepts the YHA-44A rubber flex antenna, or another antenna or feedline with an impedance of 50 ohms at the operating frequency. Do not transmit without having an antenna connected here.

## ② SQL/TONE

This squelch control sets the receiving threshold level, below which noise and (weak) signals will be silenced. Turn this control clockwise to raise the threshold and decrease sensitivity.

When the optional FTS-7 subaudible tone squelch encoder/decoder is installed in the transceiver\*, setting the SQL control fully counterclockwise into the TONE click-stop will activate the FTS-7, thus silencing the receiver to all signals that do not carry the programmed subaudible tone.

\* not available for (European) versions having Tone Burst.

## ③ VOL/OFF

When this control is set into the click-stop, the transceiver is switched OFF. During operation, this control sets the volume of the receiver in the internal or external speaker or earphone.

## ④ +5 kHz

Press this button to add five kilohertz to the operating frequency (both transmit and receive), for operation on channels that are odd multiples of 5 kHz.

## ⑤ EAR and MIC jacks

These two jacks are both used by the optional YH-2 Headset or MH-12A2B Handy Speaker/Microphone. Except when using the YH-2, an optional earphone may be connected to the EAR jack, either directly or through the MH-12A2B plug. The corresponding microphone and speaker within the transceiver are disabled when connections are made to the respective MIC and EAR jacks.

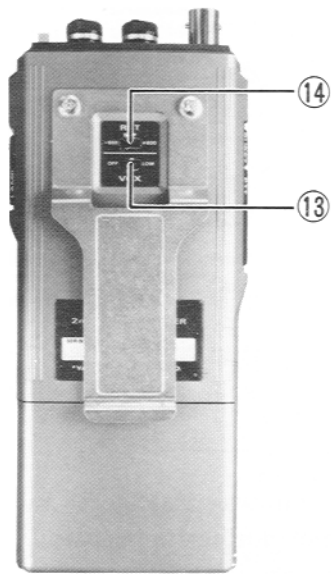
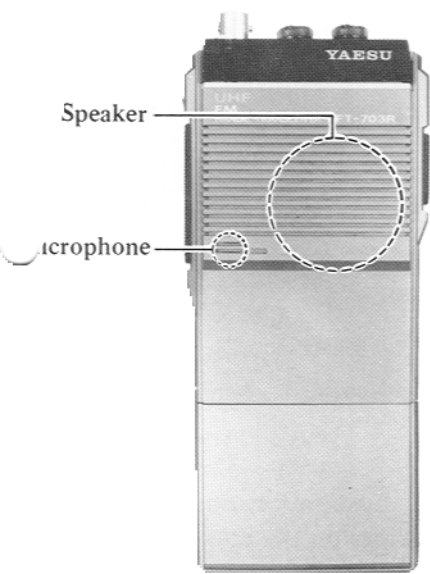
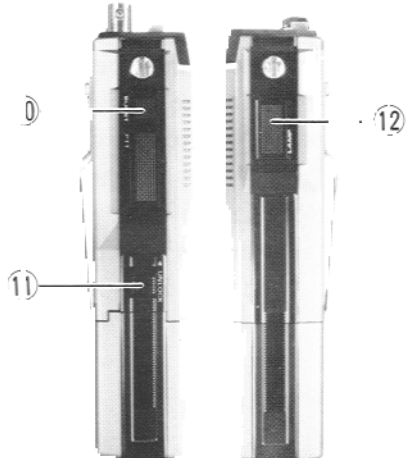
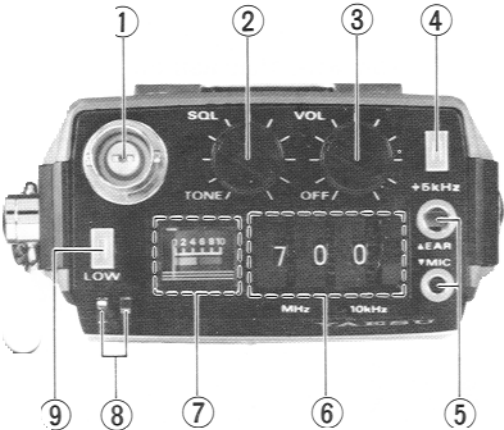

## ⑥ Thumbwheel Switches

These three rotary switches select the receiving frequency to the nearest 10 kHz (5 kHz may be added using the button with that name). The left-most thumbwheel switch, labelled MHz, selects the megahertz digit, while (unlabelled) switch in the center selects the 100-kilohertz digit. The switch labelled 10 kHz at the right selects the 10-kilohertz digit. The transmit frequency is the same as the receive frequency unless the RPT switch on the rear panel is set for a repeater split. The tens and hundreds of MHz of the frequency are not indicated.

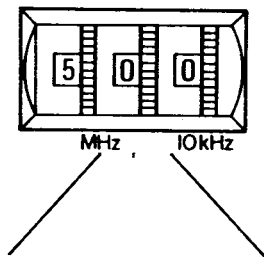

(MHz)	(100kHz)	(10kHz)
0 - 440MHz (430MHz)	0 - 0kHz	0 - 0kHz
1 - 441MHz (431MHz)	1 - 100kHz	1 - 10kHz
2 - 442MHz (432MHz)	2 - 200kHz	2 - 20kHz
3 - 443MHz (433MHz)	3 - 300kHz	3 - 30kHz
4 - 444MHz (434MHz)	4 - 400kHz	4 - 40kHz
5 - 445MHz (435MHz)	5 - 500kHz	5 - 50kHz
6 - 446MHz (436MHz)	6 - 600kHz	6 - 60kHz
7 - 447MHz (437MHz)	7 - 700kHz	7 - 70kHz
8 - 448MHz (438MHz)	8 - 800kHz	8 - 80kHz
9 - 449MHz (439MHz)	9 - 900kHz	9 - 90kHz

## ⑦ Meter

The meter indicates relative signal strength during reception, and relative power output during transmission. The markings on the meter scale are for relative comparisons only.



## ⑧ Indicator LEDs

The green LED indicates that the receiver squelch is open, either by noise (if the squelch threshold is set very low), or by a received signal. In normal operation, this LED is used as a “busy channel” indicator to provide a visual indication of an occupied channel. This function is important when monitoring in a noisy environment or with the volume reduced, but especially when the optional FTS-7 Tone Squelch option is installed. This LED does not function when transmitting.

The red LED indicates that the transceiver is in the transmit mode, and that RF energy is being transmitted. The receiver is disabled while the red LED is lit. If the transmitter is activated and this LED fails to light, or lights only dimly (in comparison with the green LED during reception), then a weak battery is indicated. Switch to low power and replace (or recharge) the battery as soon as possible.

The best viewing angle for the LEDs is straight down from above.

## ⑨ LOW (Power Button)

When this button is depressed, the RF output power during transmission is just a few hundred milliwatts, and power drain from the batteries is minimal, providing maximum battery (charge) life. When in the un-depressed position, RF output power during transmission is several watts, with power drain from the batteries correspondingly higher. In some cases, this (high) power selection will provide the extra punch necessary to maintain communications. However, the wise operator develops a habit of always keeping this switch in the LOW (depressed) position, except when operating the transceiver from an external power supply, or when absolutely necessary.

## ⑩ PTT Button (Left Side: and BURST on some models)

Press the PTT (Push-to-Talk) button to transmit. The BURST button is used to transmit an audible burst tone to access repeaters that require this, when using a transceiver so equipped (not generally required outside of Europe).

### ⑪ ◀ UNLOCK (Left Side)

To remove the battery pack, slide this spring-loaded latch upward while moving the battery pack toward this side of the transceiver.

### ⑫ LAMP Button (Right Side)

Press this button to illuminate the meter, when required.

### ⑬ VOX Slide Switch (Rear Panel)

When the optional YH-2 Headset is used with the transceiver, this switch selects VOX (voice-actuated transmit/receive) switching. The HI position selects for quiet environments, providing maximum sensitivity of the VOX circuit to sound at the boom microphone on the YH-2. The LOW position desensitizes the VOX circuit to minimize triggering by extraneous sounds when operating in a noisy environment. The VOX switch is disabled when the YH-2 is not used.

### ⑭ RPT Slide Switch

This switch selects either simplex (SIMP) operation, or plus or minus standard transmitter frequency offsets for repeater operation.

A & X	±5 MHz
B	-7.6 MHz
C	+1.6 MHz

## ANTENNA CONSIDERATIONS

While the supplied rubber flex antenna provides maximum convenience for short-range portable operation, the standard BNC-type antenna connector on the transceiver allows for the use of higher gain antennas for extended range and base station operation. However, any antenna connected to the transceiver must have an impedance close to 50 ohms in the operating frequency band. Also, if the antenna is to be connected with a feedline to the transceiver, high quality 50-ohm coaxial cable should be used.

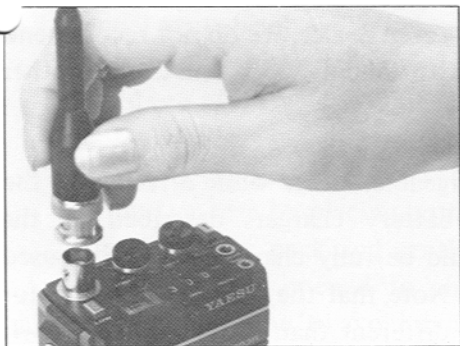

## BATTERY PACK INFORMATION

The following battery packs are commended for use with the FT-703R:

**FNB-3** 10.8V 425 mAh Ni-Cd Battery Pack

**FNB-4** 12V 500 mAh Ni-Cd Battery Pack

Also available is the **FBA-5** Battery Case for 6 AA-size dry cells (non-rechargeable, batteries optional).

In some countries, one or more of the above may be supplied with the transceiver. If not, contact the nearest Yaesu dealer. We do not recommend the use of any other type of battery with the FT-703R, and using another type may affect your warranty.

The FNB-3 and FNB-4 are both rechargeable, either while attached to the transceiver or separately, using the battery chargers described on the following pages. Each Ni-Cd pack should be fully charged before it is used with the transceiver for the first time. Note that the chargers required for the FNB-3 (except for the NC-15) are different than those for the FNB-4, because of the difference in battery voltage.

RF power output from the transmitter will differ according to which type of battery is used, with the FNB-4 providing the highest output and the FBA-5 with fresh dry cells providing about 60% less output.



**FBA-5**

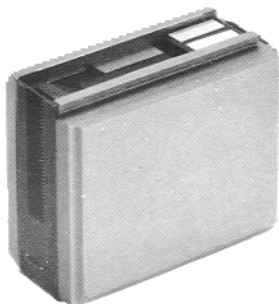

**FNB-3**



**FNB-4**

## Battery Replacement

Remove the Soft Cover from the transceiver, and make sure that the VOL control is set into the click-stop (OFF).

2. Grasp the upper portion of the transceiver with your left hand, so that your palm covers the speaker and your left thumb is on the ◀ UNLOCK button.
3. Now move the ◀ UNLOCK button in the direction indicated by the small arrowhead, while using your right hand to slide the battery case toward the side with the ◀ UNLOCK button. The battery case should slide out of its track.
4. If using the FBA-5 battery case and dry cells, they can be removed from the case by placing both of your thumbs on the mounting tracks on top of the pack and gently prying the tracks apart. Although both sides must be opened to change the cells, only one side must be opened at a time, to avoid damage to the hinges. First install or replace the three cells in one side, and then close that side, open the other side, and install or replace the other three cells. Always replace all six cells at once.
5. To replace the battery case (or Ni-Cd pack), repeat steps 2 and 3 above, simply sliding the battery case in the other direction after aligning the shorter side of the battery case with the track below the ◀ UNLOCK button.

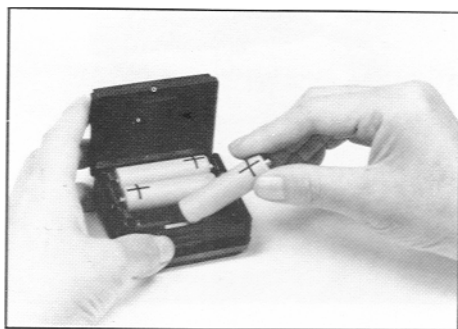
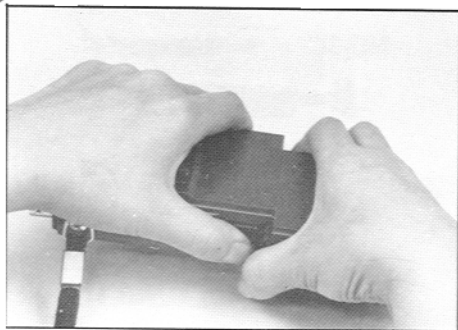

## BATTERY CHARGER INFORMATION

### NC-9B/C

The NC-9B (117 VAC) and NC-9C (220–234 VAC) are compact chargers for recharging the FNB-3 Ni-Cd battery pack from the AC line. A completely discharged pack requires approximately 15 hours to recharge with NC-9B/C. Do not attempt to charge the FNB-4 with the NC-9B/C.

### NC-18B/C

The NC-18B (117 VAC) and NC-18C (220–234 VAC) are compact chargers for recharging the FNB-4 Ni-Cd battery pack from the AC line. A completely discharged pack requires approximately 15 hours to recharge with the NC-18B/C. Do not attempt to charge the FNB-3 with the NC-18B/C.

It is not necessary to remove the battery pack from the transceiver when charging, but the transceiver can not be operated while the NC-9B/C or NC-18B/C is connected. Therefore it is advisable to have an extra battery pack on hand so that the transceiver can be used while the spare pack is being charged.



**NC-9B**



**NC-18B**

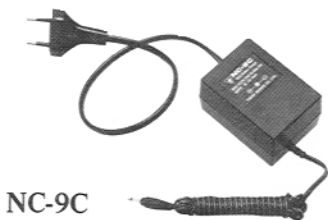

**NC-9C**



**NC-18C**

## NC-15

The NC-15 is a battery charger/DC supply with quick and trickle charging modes. The quick mode is automatically selected initially, to bring the battery pack up to full charge as fast as is safely possible. The charger then automatically reverts to the trickle charge mode, to prevent self-discharge. The quick mode recharges a completely discharged FNB-3 in about 1 hour, or FNB-4 in about 1.5 hours.

The DC power supply function of the NC-15 allows the transceiver to be operated while also charging an attached battery pack.

## PA-3

The PA-3 is a DC-DC adapter for use when operating the transceiver mobile. The PA-3 provides a regulated 10.8V DC to the transceiver and battery through terminals on the bottom of the FNB-3 or FNB-4. Battery charge is thus preserved during mobile operation. The PA-3 may be used only with 12-volt negative ground electrical systems.

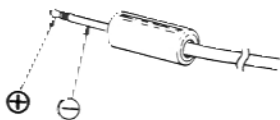

**NC-9B/C, NC-18B/C  
CHARGE PLUG  
CONNECTIONS**

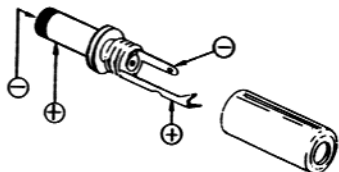

**EXTERNAL DC POWER PLUG  
CONNECTIONS**

**(Use with the FNB-3/FNB-4)**



**FT-703R/NC-15**

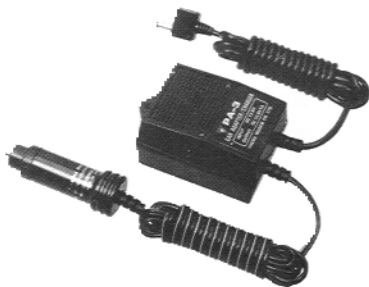

**PA-3**

## **YH-2 HEADSET and MH-12<sub>A2B</sub> SPEAKER/MIC**

Either of these two optional accessories can be used to increase operating convenience and extend operating range and signal strength. Each is equipped with a dual plug connector which mates with the EAR and MIC jacks on the top panel of the transceiver, disabling the internal speaker and microphone. The connecting cable then allows the transceiver to be left clipped to the belt during operation, or to be held above any obstructions for improved performance, if necessary. For mobile operation with the MMB-21 Mobile Hanger, the transceiver can be left in the Hanger during operation.

The MH-12<sub>A2B</sub> Speaker/Microphone can be held close to your ear during reception; or if preferred, an external earpiece can be connected to the transceiver via the speaker/mic plug, thereby attenuating the audio from the speaker in the MH-12<sub>A2B</sub>. To transmit, just hold the speaker/mic close to your mouth and close the PTT switch on the microphone.

The YH-2 Headset includes both a lightweight earphone and miniature boom microphone with a single headband, permitting totally hands-free operation of the transceiver when the VOX (voice-actuated transmit/receive switching) system in the transceiver is activated. When in a normal, quiet environment, set the VOX switch on the rear panel of the transceiver to the center (HI) position, for maximum sensitivity of the VOX circuit. If in a noisy environment where extraneous sounds might trigger the VOX inadvertently, set the VOX switch to the LOW position.

To transmit when using the YH-2, it is only necessary to speak. The boom microphone will pick up your voice, which will automatically activate the transmitter and be sent out over the air (watch what you say). To return to receive, just stop talking.





YH-2



MH-12A2B



MMB-21

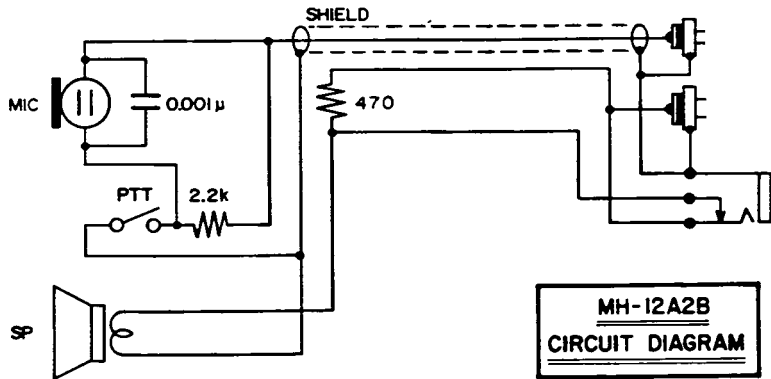
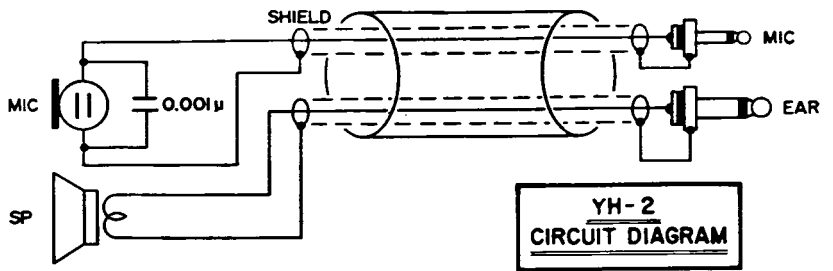

# OPERATION

Before operating the transceiver, make sure that the Ni-Cd battery pack is fully charged (if just received from the dealer, the battery pack should be charged before beginning operation). If using the FBA-5 battery case and AA-size batteries, install the batteries as described on page 11.

Connect the rubber flex antenna to the antenna jack on the top of the transceiver. Never operate the transceiver without an antenna connected.

On the top of the transceiver, set the thumbwheel switches to the desired receiving frequency, and press the +5 kHz button if necessary (for channel frequencies that are an odd multiple of 5 kHz). Press the LOW button.

On the rear of the transceiver, set the RPT switch to the - or + position if you are going to operate through a repeater. Otherwise, set this switch to the center (SIMP) position. Also, set the VOX switch to the OFF position.

VOX operation using the YH-2 Headset is described on page 14. For now, do not connect the YH-2 or the MH-12A2B Speaker/Mic.

With the VOL control set into the click-stop (OFF), set the SQL control fully counterclockwise but not into the click-stop. Now rotate the VOL control out of the click-stop and adjust for a comfortable volume on the noise or signal. If a signal is present, rotate one of the thumbwheel switches to a channel where only noise is heard.

Rotate the SQL control clockwise just to the point where the noise is silenced. If the SQL control is set further clockwise, sensitivity to weak signals will be reduced. If it was necessary to change channels to find a clear frequency, you can now return to the original frequency. Whenever a signal reaches the receiver that is strong enough to open the squelch, the green LED will light, indicated a busy channel.

To make a call when the channel is clear (green LED off), simply squeeze the PTT switch on the side of the transceiver, and speak into the microphone (MIC on the front panel).

During transmission, the red LED will light. If it does not, or becomes dim after several hours of operation, the battery pack should be recharged, or batteries replaced (FBA-5). If you are calling through a repeater that requires a burst tone (and using a transceiver so equipped), press the BURST button along with the PTT switch to send the tone. Release the PTT switch to receive. If more power is required, press the LOW button again so that it returns to the undepressed position. However, whenever communication is possible with low power, this button should be depressed to conserve battery life and to minimize possible interference to other stations.

In certain locations, when received signals or repeater access is weak or unstable, the signals may be improved by moving the transceiver around: in general, the higher the better. Either the YH-2 Headset or MH-12A2B Speaker/Microphone allow the transceiver to be held high overhead during operation. These accessories are described on page 14.

When operating in a dark environment, the LAMP button can be pressed to illuminate the meter.

If the FTS-7 Tone Squelch Unit is installed (models A or X only), rotate the SQL control into the TONE position to activate tone squelch operation. See pages 18–20 for further details of this option.

---

## Radio Manuals

[www.amateurmanuals.co.uk](http://www.amateurmanuals.co.uk)

Yaesu, Kenwood, Icom, KW, Henry, Tokyo Hi-Power, ERA, Trio, KDK, FDK, Azden, Standard, AOR, SMC, Sagra, MML, NRD, JRC, Alinco.

Amateur and Commercial/Marine

# FTS-7 PROGRAMMABLE CTCSS TONE SQUELCH ENCODER/DECODER

The FTS-7 is a DIP-switch programmable sub-audible tone generator and decoder that provides tone squelch operation using the operator's choice of 37 standard subaudible (CTCSS) tones, for silent channel monitoring and operation through CTCSS-equipped repeaters using the Yaesu FT-703R UHF FM Hand-held transceiver (models A and X only).

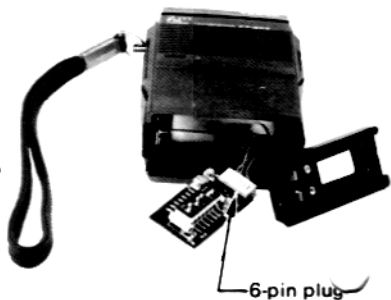

## Installation

Set the VOL control into the click-stop (OFF), and remove the battery pack. Referring to the photo below, remove the four screws affixing the battery mounting track, and remove the track.

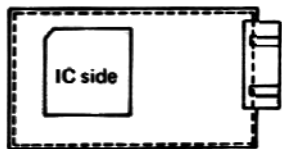

2. Locate the 6-pin plug inside the bottom of the transceiver, and connect this plug to J<sub>01</sub> on the edge of the FTS-7 (See diagrams at right).

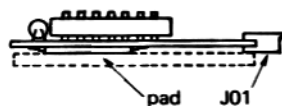

3. Apply the double-sided adhesive pad (supplied with the Kit) to the IC side of the FTS-7, and mount the FTS-7 inside the bottom of the transceiver as shown below. Now replace the battery mounting track and its four screws.

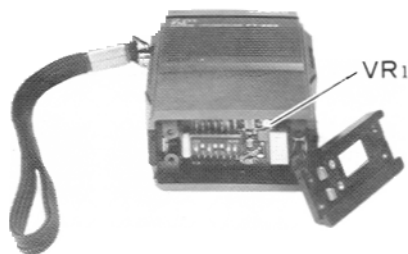
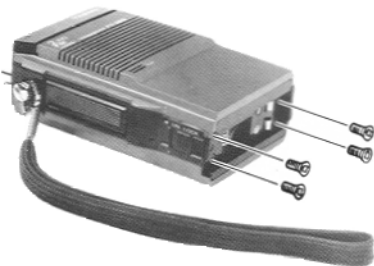

## Programming

With the battery pack removed, refer to the DIP Switch Programming Chart below, and set the six switches on the FTS-7 for the desired tone (the switches should be accessible through the hole in the bottom of the transceiver). Note that "o" in the Chart indicates that the switch should be set to the "ON" position. Switch number 7 should only be set to the "OFF" position if tone squelched reception is not to be used while CTCSS transmission is required.

### EXAMPLES

FREQ	SWITCH NUMBER *					
	1	2	3	4	5	6
67.0Hz	o	-	-	-	-	-

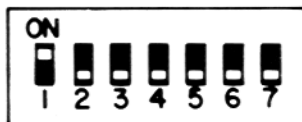

67.0Hz

↑  
ON = Enc/Dec  
OFF = Encoder only

FREQ	SWITCH NUMBER *					
	1	2	3	4	5	6
77.0Hz	o	o	-	-	-	-

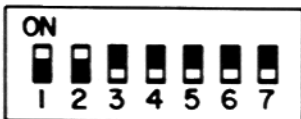

77.0Hz

FREQ	SWITCH NUMBER *					
	1	2	3	4	5	6
88.5Hz	o	-	o	-	-	-

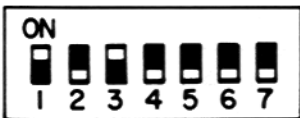

88.5Hz

## FTS-7 DIP SWITCH PROGRAMMING

FREQ	SWITCH NUMBER *					
	1	2	3	4	5	6
67.0Hz	o	-	-	-	-	-
71.9	-	o	-	-	-	-
74.4	-	-	o	-	-	o
77.0	o	o	-	-	-	-
79.7	-	o	o	-	-	o
82.5	-	-	o	-	-	-
85.4	-	-	-	o	-	o
88.5	o	-	o	-	-	-
91.5	-	o	-	o	-	o
94.8	-	o	o	-	-	-
100.0	o	o	o	-	-	-
103.5	-	-	-	o	-	-
107.2	o	-	-	o	-	-
110.9	-	o	-	o	-	-
114.8	o	o	-	o	-	-
118.8	-	-	o	o	-	-
123.0	o	-	o	o	-	-
127.3	-	o	o	o	-	-
131.8	o	o	o	o	-	-

FREQ	SWITCH NUMBER *					
	1	2	3	4	5	6
136.5Hz	-	-	-	-	o	-
141.3	o	-	-	-	o	-
146.2	-	o	-	-	o	-
151.4	o	o	-	-	o	-
156.7	-	-	o	-	o	-
162.2	o	-	o	-	o	-
167.9	-	o	o	-	o	-
173.8	o	o	o	-	o	-
179.9	-	-	-	o	o	-
186.2	o	-	-	o	o	-
192.8	-	o	-	o	o	-
203.5	o	o	-	o	o	-
210.7	-	-	o	o	o	-
218.1	o	-	o	o	o	-
225.7	-	o	o	o	o	-
233.6	o	o	o	o	o	-
241.8	-	-	-	-	-	o
250.3	o	-	-	-	-	o

\* DIP SW o = ON

DIP SW NO o ON = TONE SQUELCH  
OFF = ENCODER ONLY

## Tone Level Adjustment

The tone output level of the FTS-7 is preset at the factory for the standard level, and normally requires no readjustment. However, if a particular situation requires a different tone level, this may be adjusted by trimmer potentiometer VR<sub>01</sub>, shown in the right-hand photo at the bottom of page 18.

## Operation

To activate the FTS-7, simply set the SQL control fully counterclockwise into the click-stop (TONE). During reception, the transceiver will remain silent until a signal is received that includes the programmed subaudible tone, at which time the squelch will open and the station will be heard as usual. When the transmitter is activated, a subaudible tone will be superimposed upon your voice signal, so that those stations equipped with a CTCSS decoder set to the same tone frequency will hear your call. Stations not equipped with tone squelch units will also be able to hear your transmissions, but you will not hear them when they transmit. Normal operation remains the same when the SQL control is rotated out of the TONE position.

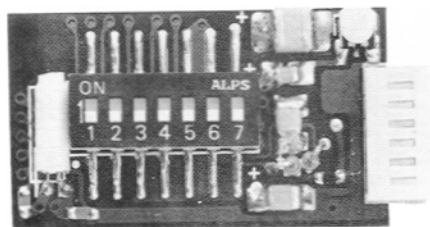

**FTS-7**

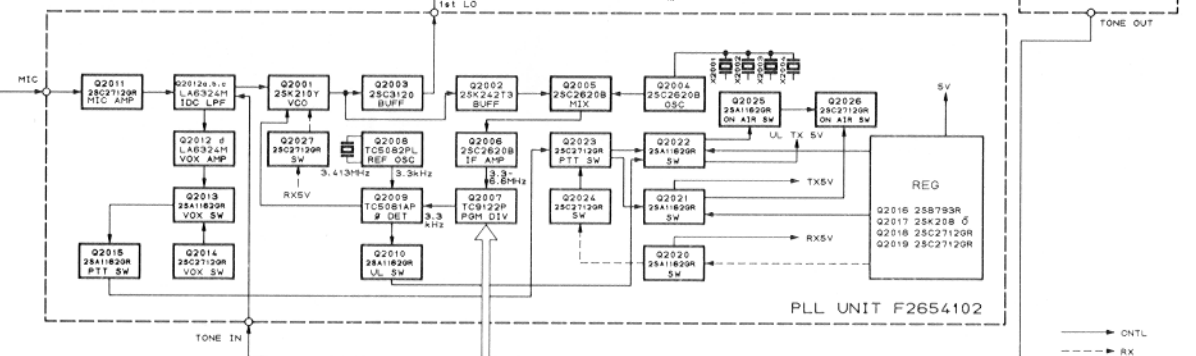
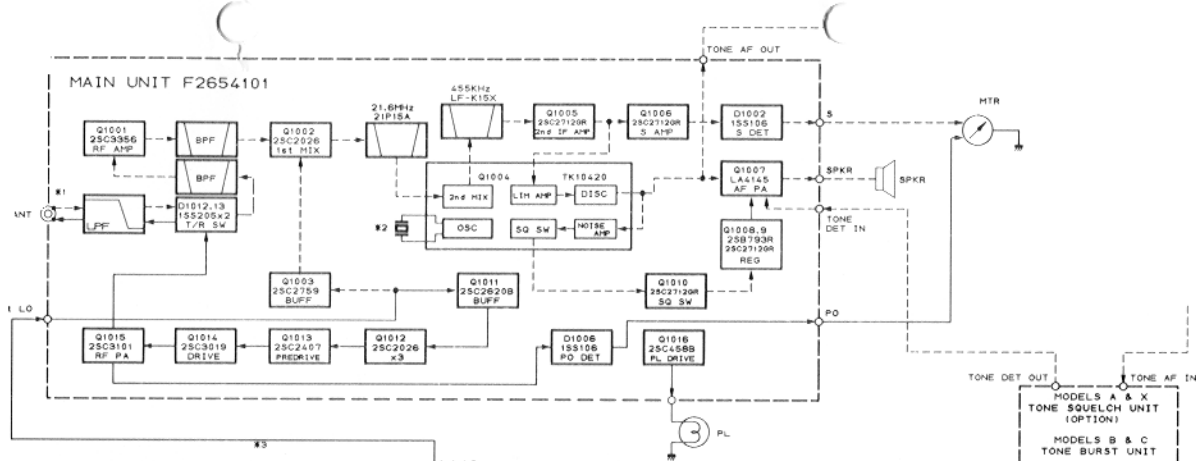

	W1 [MHz]	W2 [MHz]	W3 [MHz]
A	440.000-449.995	22.055	RX:139.667-142.7883 TX:146.667-149.9983
B,C,X	430.000-439.995	21.145	RX:139.333-139.4655 TX:143.3333-146.6655

	X2001 [MHz]	X2002 [MHz]	X2003 [MHz]	X2004 [MHz]
A	136.133	141.666	143.333	145.000
B	132.000	137.468	140.000	
C	132.000		140.000	140.535
X	132.000	138.333	140.000	141.666

