

W43 | 24 | 21
D. THORNE

AR7

**INSTRUCTION BOOK
COMMUNICATION RECEIVER
TYPE D.F.
KINGSLEY RADIO PTY. LTD. MELB.**

I N D E X

Section A.	Mechanical Construction Receiver.	Page 3.
	Power Supply Unit	Page 3.
Section B.	Design	Page 3.
	Electrical Characteristics	Page 3.
Section C1.	Controls	Page 4.
Section C2.	Aligning Procedure	Page 6.
	Maintenance	Page 10.
Section D.	Operation	Page 10.
Section E1.	Power Supply	Page 11.
Section E2.	Valves	Page 12.
	Protection Fuse	Page 12.
Key to Circuit and Schedule of Parts		Pages 13 and 14.
Instructions for Direction Finder		Pages 15 to 19.

Section A.

1. MECHANICAL CONSTRUCTION - RECEIVER.

The Receiver is constructed of No. 18 gauge sheet metal. The frame is a spot-welded fabrication heavily reinforced with angle pieces and gusset plates to ensure durability and complete rigidity.

On completion of fabrication the frame is given a heavy coat of copper plating of not less than one thousandth of an inch. This plating is to provide a path for complete grounding throughout the chassis.

As a safeguard against corrosion the whole is then Cadmium plated. Moisture will have no effect on this final coating. The electrical contacts on the Coil Acceptor Unit are constructed of phosphor bronze, heavily silver plated. These contacts are self cleaning.

2. POWER SUPPLY UNIT.

The frame of this Unit is fabricated and plated in the same manner as that of the receiver. Both Units are fitted with Dust Covers thoroughly ventilated and finished with Grey Crackle Lacquer.

Section B.

1. DESIGN.

The basis of design of this Receiver is to provide stable operation at all frequencies between 138 K.C. and 25 M.C. with an R/F input of 1 microvolt absolute or better. The Receiver is designed to operate from standard 230V. A.C. mains supply, or in an emergency from a 12V. Accumulator. The Power Unit Selection Switch provides instant selection of either of the above supplies on its front panel.

2. ELECTRICAL CHARACTERISTICS.

The following measurements are an average as measured on test:-

(a) Frequency Coverage - 138 K.C. to 25 M.C. in 5 bands with a gap of 45 K.C. on either side of the I/F channel, which is 455 K.C.

(b) Sensitivity - The absolute sensitivity is such that an input voltage of 1 microvolt modulated to a depth of 30% at 400CPS. applied through the following dummy antenna to the Receiver aerial terminals gives 6 milliwatts into a 12,000 ohm non-inductive load with a signal to noise ratio of 1 - 1 in watts.

(c) Selectivity - by a variation of input voltage against constant output:-

6 K.C. off resonance	20DB down
10 K.C. " "	40DB "
15 K.C. " "	60DB "

With Crystal Filter in, a selectivity of 100CPS. may be achieved.

(d) Automatic Volume Control - The output remains constant to within ± 3 DB for variations of input voltage between 10 microvolts and 1 volt. *20-1700*
 ± 10 DB between limits of 10 μ V & 500000 μ V

(e) Stability - every precaution has been taken in the design to achieve stability of operation. Regulation of the power supply when working on the standard A.C. supply is such as to take care of variations of line fluctuations of $\pm 10\%$

(f) Power Output - the Receiver delivers the following power output.

To Headphone Circuit	<i>300</i> 100M/Watts
To 600 ohm output	100M/Watts
To Speaker of 1750 ohm impedance	1.8 watts.

This measurement is made with 100% modulation at 400 CPS.

(g) Radio Frequency Amplifier - two stages of R/F. amplification are employed in this Receiver.

The signal to image ratio thus provided is as follows:-

Band.

- A. > 2000 to 1
- B. > 2000 to 1
- C. > 2000 to 1
- D. > 2000 to 1
- E. At 22MC. 500 to 1, at 12MC. 2000 to 1.

Section C.1.

1. Controls. The front panel on to which the Controls are terminated is clearly marked. In order that the Controls may be identified from this description reading from left to right read in three rows as follows:-

Top Row.

Signal Meter, Tone Control, Tuning, Noise Limiter.

Middle Row.

BFO. Note Control, AVC/BFO Switch, Meter Adjust, Variable Selectivity, Crystal IN/OUT Switch, Crystal Phasing Control.

Bottom Row.

Manual R/F. Gain Control, Coil Box Acceptor, Audio Gain.

Left Hand Bottom. Phone Jack 1.
Right Hand Bottom. Phone Jack 2.

Functions of Controls.

Signal Meter. An indicator of carrier strength of the received signal.

Tone Control. Arranged to reduce high frequency response to minimise static or other interference.

Tuning Control. Controls 4 gang Condenser, effects band spread on all bands - equals pointer travel on a scale approximately 12 feet long.

Noise Limiter. This ^{SWITCH} control is arranged to limit the noise peaks so that in no case can they exceed the signal level, particularly useful to adjust the signal - noise ratio when receiving C.W. "BISHOP" FULL WAVE SHUNT TYPE

B.F.O. Note Control. Arranged to shift the note of the beat frequency oscillator \pm 2000CPS. either side of zero beat.

AVC/BFO Switch. Used in AVC. position for reception of telephone signals - when turned to BFO. brings in BFO. and eliminates AVC. for reception of C.W. signals. SWITCH POSITIONS ANTI-CLOCKWISE
AVC ON, STEP 2. AVC + BFO ON, 3. BFO ON AVC OFF, 4. AVC OFF BFO ON, 5. AVC ON, BFO ON

Meter Adjust. Used to adjust signal meter to zero under no signal conditions.

Variable Selectivity Control. This control is used only in conjunction with the crystal filter. With the filter inactive the control has no effect. When the control is on 0 the receiver is in the broad position, 10 provides maximum selectivity.

Crystal IN/OUT Switch. With this switch on the IN position the crystal filter functions. Fine adjustments are then made on "Selectivity".

Phasing. The Crystal Phasing Condenser should be in the Zero position for normal operation and should not be used unless an interfering signal appears. The method of operation for rejection of an interfering signal is to move the tuning dial a fraction "off peak" and adjust the Phasing Condenser right or left of Zero until the interfering signal is eliminated or reduced.

Manual R/F. Gain Control. This controls the sensitivity of the Receiver irrespective of the A.V.C. Greater than 60dB

Coil Box Acceptor. In the space provided the operator inserts the coil box unit required. Each unit is marked with its band letter:-

<u>Band.</u>	<u>Tuning Range.</u>
A.	133K.C. to 409K.C.
B.	495K.C. to 1430K.C.
C.	1420K.C. to 4.32 M.C.
D.	4.25M.C. to 12.6M.C.
E.	12.5 M.C. to 25 M.C.

The curve engraved on each coil box front is Frequency versus Dial degrees.

Audio Gain - (Stand By Control. ^{← NOT OPERATIVE}) A combined Stand By Switch and Audio Gain control - when turned to "Stand By" H.T. is switched off but the valve heaters remain on. When the Pointer is advanced to "on" the Receiver is active and further advance of the pointer towards 10 increases audio gain. *Not less than 30 DB*

Phone Jacks 1 and 2. When telephones are plugged into Phones 1. the speaker is automatically silenced - ~~Phones 2. is a jack provided for a second pair of operators telephones, but no audio power is available in Phones 2 unless a headset is plugged into phones 1.~~ *Phone jacks 2, only, connected. (600 OHM). This is now 2 Ohm voice coil connection.*

Section C. 2.

ALIGNING PROCEDURE.

I.F. Amplifier. Extreme accuracy is required in the alignment of the I/F. circuits. Unless there is very good reason to suspect incorrect alignment and the operator has all the necessary facilities for this work it should not be attempted.

Slight misalignment of these transformers will have a marked effect on the sensitivity and selectivity of the Receiver, and as they are of the extremely stable type using permeability tuning and silver plated mica fixed condensers, it will be found that one or two turns in or out of the iron core slug is all that is necessary to bring them to their original adjustments.

Procedure. The following instructions should be read through carefully and fully understood before starting adjustments:-

Disconnect aerial leads and power and speaker cables. Take dust cover off and remove Receiver from rack. Stand on side with underneath facing right and away from rack. Reconnect power and speaker cables, but not the aerial leads. Connect an output meter adjusted for 600 ohms across the 600 ohm output terminals. (See circuit). An ordinary 0-5 volt copper oxide rectifier type A.C. meter with a 600 ohm, 1 watt carbon resistance across it is quite suitable for this purpose.

Remove the grid lead from the top cap of the 6K8G valve. Connect the output of a calibrated signal generator to the grid cap of the 6K8G. preferably through a condenser of approximately .005mfd. capacity and return the grid to earth through a

100,000 ohms, 1 watt carbon resistor.

Connect the grounded side of the signal generator output to chassis. Set "S" meter to zero no signal.

Set controls as under:-

Crystal switch in the OUT position. Selectivity control on 0. Phasing condenser to centre scale. BFO-AVC Switch to A.V.C. Tone control on 10. Noise limiter on 10. Audio Gain control on approximately 3.

Adjust signal generator to exactly 455 kilocycles, modulated 30% at 400 cycles, and turn attenuator until a reading of approximately 6 milliwatts or 1.9 volts appears on the 0 - 5V. output meter.

Adjust the iron core slug screws which appear through top and bottom of the I/F transformers. Those appearing above chassis are the grid circuits and underneath chassis, plate circuit, except in the case of T.2. crystal filter grid circuit, which appears also underneath chassis, and is the nearest screw to the chassis side (farthest away from 6K8G valve). This should not be touched until later.

Adjustments. 1. Using a lining up tool e.g. screwdriver of insulating material or at least only a small portion of the tip metal, start from T.1. (See Photostat) turn iron slug screws in or out, until a maximum reading on the output meter appears with the minimum input from the generator.

2. Switch in crystal, set selectivity control on 10 and phasing control to centre scale:-

Adjust attenuator until a reading of approximately half scale appears on the "S" meter, at the same time keeping the audio gain at a position where approximately 6 milliwatts appears on the output meter.

3. Rotate generator slowly over 455 kilocycles, noting the peak on "S" meter. If one sharp peak only is observed the I/F alignment is correct, should however, two peaks appear, this will show incorrect calibration or inaccurate setting of generator, and it should be set again on the centre of the peak which appears the sharper. This being 455 kilocycles - the crystal frequency.

Again readjust the iron slugs, excepting grid circuit in T.2. and T.4. for maximum peak on "S" meter with minimum input from generator. Adjust T.4. grid circuit for maximum peak on output meter. After carefully checking these circuits several times, only one sharp peak should appear on the "S" meter and the sensitivity of these circuits should be in the order of 10 microvolts. That is to say, with a 10 microvolt input and 6 milliwatts output, on switching the generator modulation off, the output should drop to 3 milliwatts due to noise with the crystal in the "OUT" position.

With the crystal in, the signal to noise ratio should be improved and again further improved as the selectivity is increased after aligning T.2. crystal filter grid circuit, which is done as follows:-

Insert Coil Unit "B" and tune in a broadcast station. Switch crystal in and set selectivity control on 0. Adjust T.2. for the best tonal qualities of music, taking no notice of loudness. When the dial is rotated slowly over the station the effect noticed should be the same as with the crystal out, except for an additional sharpness. On either side of the correct position, the tone will be low and drummy and as the dial is rotated over the station a distinct hollowness, due to the crystal filter cutting the side bands, will appear on either side of the station. This adjustment is to obtain a symmetrical and variable crystal selectivity curve and should be done with a frequency modulated signal generator and cathode ray oscillograph, although the above instructions are satisfactory for normal service use.

B.F.O. Adjustment. The Beat Frequency Oscillator should be set at exactly 455 K.C. when the note control is at centre scale.

A simple method to check the setting is to switch off the signal generator and switch in the crystal filter with selectivity control at 10. Rotating the B.F.O. note control a distinct sound will be heard as the oscillator passes over the crystal frequency to an apparent zero beat. This should appear when the B.F.O. note is at centre scale. Should this setting be out, it may be corrected by adjusting the iron core slug through the hole in the B.F.O. shield under chassis (See Fig.A.)

Having perfectly aligned the I/F circuits, remove generator connections and replace 6K8G lead on the top cap of the valve, and remove 100,000 ohm 1 watt carbon resistor.

R/F and H/F Oscillator Circuits. As with the I/F Amplifier extreme accuracy is required for the R/F and H/F Oscillator circuit alignment. As the components employed in these circuits are of extremely stable type, having been thoroughly baked and treated with trolitol solution, using air trimming condensers, high quality insulating materials etc. only a fraction of a turn of the trimming condensers and small adjustment of the coil inductance is all that is necessary to restore the circuits to original efficiency. These adjustments should be made only if the operator is certain it is necessary through valve replacements, rough handling or extreme temperature changes, and he has the facilities and experience to do so.

Adjustments. The adjustments are made through the holes in the coil acceptor housing and are marked L1 to 4, C1 to 8 as shown in Fig. A.

- L.1. Inductance adjustment on aerial coil.
- L.2. Inductance adjustment on first R/F coil.
- L.3. Inductance adjustment on second R/F coil.
- L.4. Inductance adjustment on H/F Oscillator coil.
- C.1. Trimmer condenser on aerial coil.
- C.2. Series trimmer Coil E.
- C.3. Trimmer condenser on second R/F coil.

- C.4. Series trimmer Coil E.
- C.5. Trimmer condenser on second R/F coil.
- C.6. Series trimmer Coil E.
- C.7. Trimmer condenser on H/F Oscillator coil.
- C.8. Padder series condenser on H/F Oscillator coil.
Bands A,B,C, series trimmer Coil E.

Procedure. Remove receiver from rack and connect output meter as described in I/F procedure. Connect the output of standard signal generator through the standard dummy antenna supplied with the signal generator, to the antenna terminal A.1. The earth terminal of the dummy antenna being connected to terminal A.2. on the receiver. Bridge antenna terminal A.2. and earth terminal together, and ground earth terminal. Plug in coils in turn. Check the calibration of coils, preferably using an unmodulated test signal of approximately 10 microvolts, and the B.F.O. on, with B.F.O. note control set at centre scale i.e. exactly on 455 kilocycles. Observe that zero beat occurs on the correct dial setting. Should this be so the calibration is correct and there will be no need for adjustments to the H/F. Oscillator circuit. If not, a small adjustment of C.7. will correct at high frequency end, or adjustment of L.4. at low frequency end, except in Band E. where there is no inductance adjustment but a series trimmer. Here C.8. is adjusted as L.4. If Band A. will not follow calibration C.8. series padder may be adjusted - resetting C.7. and L.4. As these two settings mutually affect each other, they may have to be rechecked several times. Check R/F grid circuits with B.F.O. off and modulation on generator, tune in signal at approximately 15 degrees on dial then adjust trimmer condensers C1, C3, C5 for maximum peak on "S" meter with minimum input from generator. As there is a certain amount of interlocking between the R/F circuits and H/F oscillator circuit at the highest frequencies, it will be necessary to rotate the tuning dial to and fro over the signal to obtain the correct setting (greatest peak) rechecking the oscillator calibration several times.

Band A. Some difficulty may be experienced on this band with oscillation, if far out of alignment. This is because the R/F. circuits are resonating at too high a frequency or near the intermediate frequency, causing instability and difficulty to align. If the Oscillator section is corrected as above and grid circuits adjusted individually by connecting the generator to grid cap of the second and first R/F valve, taking care not to set at a higher frequency than 409 K.C., the difficulty may be overcome.

After checking at the highest frequency of each band, adjust inductances L.1, L.2. and L.3. for maximum peak at lowest frequencies. After rechecking each end several times and the operator is satisfied the adjustments are correct the receiver should have a sensitivity of approximately 1 microvolt when modulated 30% with signal to noise ratio of 1 - 1 in watts or better, and a signal to image ratio of not less than 400 to 1 at the highest frequencies.

MAINTENANCE.

In designing the K/CR/11 a very wide margin of safety in components has been maintained and years of satisfactory service should be received without having to tamper with the receiver. Should troubles occur these may be classified as under:-

Valves. Check by replacement or on the standard type V.C.T. valve tester.

Condensers. May be located by point to point continuity test.

Resistors. May be located by point to point continuity and voltage test.

Other components and intermittent defects. These may be found by localising the trouble to some particular circuit and making tests or by a process of elimination.

Hereunder is a list of D.C. voltages which should appear at socket points. These are read with a 1000 ohm per volt meter using the scale indicated in brackets under voltages. (The multi-meter associated with the standard type V.C.T. valve tester should normally be used).

With controls set as under:-

R/F gain control on 10.

Noise Limiter on 10.

BFO/AVC Switch on AVC.

Aerial removed and 6K8G grid shorted to earth so that no noise or signal will work A.V.C. read as follows:-

Socket	6U7G	6U7G	6K8G	6U7G	6U7G	6G8G	6V6	6C8G	6X5G	6X5G
Pin number	1st	2nd	Osc	1st	2nd	2nd	DetOut-	S.Met.	Rect.	Rect.
to Ground	R/F.	R/F.	1 Det.	I/F.	I/F.	1st	Aud.put	BFO.		
3	200	200	205	200	200	32	215	240	-	350
	(Set Meter to 0-1000 volts D.C. Scale) for 6G8G Reading AC.									
4	95	80	100	95	80	-	240	-	-	-
6	-	-	100	95	80	18	-	scale	-	-
	(Set meter to 0-1000 volts D.C. for 6G8G reading)									
8	2.5	2	3	2.5	2	.8	13	-		275
						(10)				D.C.

Section D.

OPERATION.

In order to bring the Receiver to an operating condition, observe the following procedure:-

- (a) Insert the appropriate coil unit.
- (b) See that the Stand By Switch is in the OFF position.

- (c) See that the switch on the power supply unit is in the OFF position.
- (d) Connect A.C. supply to the power supply unit and a 12 volt accumulator to the battery cable.
- (e) Connect an aerial and earth to the terminals marked A1 and E respectively and bridge the terminals marked A2 and E. - or if using a doublet aerial connect the two aerial leads to the terminals marked A1 and A2 and earth E.
- (f) Switch power supply to either of the ON positions, i.e. 230 volt A.C. or 12 volt D.C.
- (g) Wait $\frac{1}{2}$ minute and then turn stand by switch to ON position with noise limiter control set on about 8.
- (h) In conjunction with the tuning curve on the face of the coil unit and the AVC/BFO switch in the AVC position - tune for phone with Crystal out - or for C.W. signals with Crystal in and variable selectivity control on O. The B.F.O. switch should be on BFO position and the B.F.O. note control central.
- (i) Having found the desired signal the variable selectivity control may be advanced to the desired selectivity.

NOTE. With the Crystal in and the variable selectivity control on O the full sensitivity of the receiver is preserved, i.e. no loss of signal should occur.

When it is desired to change back to phone reception simply turn BFO/AVC switch to A.V.C. position and carry on. Noise limiter control should be adjusted for the best signal to noise ratio in a bad location, but always initially tune in the station with noise limiter control on 8 to 10.

Section E.1. POWER SUPPLY.

There is only one control on the power supply unit. This is a 3 position switch, the positions being centre off - L/H. 12 V. D.C. - R/H. 230V. A.C. The turning of this control changes the supply instantly.

Power Consumption:

43.75-watts at 230V A.C.

44.2 watts at 12V D.C.

Section E.2.

VALVES.

Each Receiver is despatched with one complete set of valves.

Protection Fuse.

As a protection against faulty Rectifier tubes or a breaking down condenser an miniature E.S. lamp is included as a fuse. This is located on the under side of the Power Unit Chassis. Should this lamp blow, tests should be made on condensers and tubes before replacing the fuse.

Replace with miniature E.S. lamp of 4.5 to .6 amp, 2 to 8 volts.

KINGSLEY RADIO PTY. LTD.
380 St.Kilda Road,
MELBOURNE, S.C.1.

KEY TO CIRCUIT AND SCHEDULE OF PARTS

444

Part No. on Drawing	Value	Description	Part No. on Drawing	Value	Description
<u>Condensers. Figure 1.</u>			<u>Condensers Figure 1.</u>		
C1, C2, C3, C4	Variable	4 Gang Modified Type H. Stromberg & Dial.	C35.	100mmf.	Chanex Mica
C5.	.05	Chanex 600V. or TCC.	C36.	.1	Chanex or TCC.
C6.	.1	" " " "	C37.	.01	Chanex Mica
C7.	.1	" " " "	C38.	.1	Chanex or TCC
C8.	.5	Chanex 400V.	C39.	25mf.	40V. Electrolytic
C9.	.05	" or TCC.	C40.	.005	Chanex Mica
C10.	.1	" " "	C41.	BFO	3 plate midget Kingsley
C11.	.1	" " "	C42.	MEC	BFO. Coupling
C12.	.5	" 400V.	C43.	.5	Chanex 400V.
C13.	.1	" or TCC.	C44.		
C14.	100mmf.	Mica Chanex	C45.		
C15.	.05	Chanex or TCC	<u>Resistors Figure 1.</u>		
C16.	.5	Chanex 400V.	R1.	100,000	Watt ETC or Chanex
C17.	.1	Chanex or TCC.	R2.	250	" " "
C18.	8mf.	600V. Ducon Aerovox	R3.	30,000	" " "
C19.	.05	Chanex or TCC	R4.	50,000	" " "
C20.	.1	" " "	R5.	5,000	" " "
C21.	.1	" " "	R6.	100,000	" " "
C22.	.5	"	R7.	250	" " "
C23.	.05	Chanex or TCC.	R8.	40,000	" " "
C24.	.1	" " "	R9.	50,000	" " "
C25.	.05	" " "	R10.	5,000	" " "
C26.	.05	" " "	R11.	250	" " "
C27.	.1	" " "	R12.	50,000	" IRC.
C28.	.5	" 400V.	R13.	12,500	" W.W. Kingsley
C29.	100mmf	" Mica	R14.	10,000	" ETC or Chanex
C30.	250mmf	" "	R15.	100,000	" " "
C31.	25mf.	40V. Electrolytic	R16.	3,500	Pot. Kingsley Special
C32.	100mmf.	Chanex Mica	R17.	300	1/2 watt ETC or Chanex
C33.	.01	" "	R18.	50,000	" " "
C34.	.1	Chanex or TCC.	R19.	5,000	W.W.Pot. R.F. Control

KEY TO CIRCUIT AND SCHEDULE OF PARTS.

Part No. on Drawing	Value	Description	Part No. on Drawing	Value	Description
<u>Resistors Figure 1.</u>			<u>Condensers. Figure 2.</u>		
20.	30,000	$\frac{1}{4}$ watt ETC or Chanex	C1.)		
21.	50,000	" " "	C2.)	.01 Mica	Chanex
22.	5,000	$\frac{1}{4}$ watt " " "	C3.)		
23.	100,000	" " "	C4.)		
24.	300	" " " ETC or "	C5.)		
25.	50,000	" " "	C6.	.5	Chanex
26.	40,000	" " "	C7.	.5	" "
27.	50,000	" " "	C8.	.1	" or TCC
28.	5,000	" " "	C9.	.01 Mica	" "
29.	250,000	" " "	C10.)		
30.	500,000	" " "	C11.)	.1	" or TCC
31.	500,000	" " "	C12.	.1	" "
32.	5,000	W.W. Pot	C13.	.01 Mica H.V.	Simplex
33.	100,000	$\frac{1}{4}$ watt " "	C14.	.01 " "	" "
34.	500,000	Pot. & Switch (Stackpole)	C15.)		
35.	1,000	ETC or Chanex	C16.)	8mf. 600V.	Electrolytic
36.	500,000	$\frac{1}{4}$ watt ETC or Chanex	C17.)		
37.	500,000	Pot. Stackpole	C18.	.1	Chanex or TCC
38.	1 meg.	$\frac{1}{4}$ watt ETC or Chanex	C19.	.1	" "
39.	250,000	" " "	C20.	.1	" "
40.	50,000	" " "			
41.	500,000	" " "			
42.	300	W.W. IRC. 3 Watt			
43.	50,000	Pot. Stackpole	F. Fuse 6.3 Vor 3.5V.	.3amp. Min.E.S.	Lamp
44.	500	$\frac{1}{2}$ watt ETC or Chanex	<u>Fig. 3.</u>		
45.	2,000	$\frac{1}{2}$ " " "	R46.	42 ohm W.W.	IRC

OPERATION OF DIRECTION-FINDER.

4 MAY 1942

CONNECTION.

HOBART

1. Remove the lid and place the receiver in position of operation
2. Lift lid and place power unit about 18" behind and to the right of receiver (where it will not be in the way of the loop operator).
3. Place 12 Volt battery behind power unit and connect battery cable (short wire of 40/36 cabtire flex) to battery and insert power plug to receiver power connection through shutter at back. Connect speaker or phones as required.
4. Remove loops from housing in lid and insert large loop into loop switch box, which is placed in position on bearing pointer socket. Extend telescopic aerial and insert in vertical. aerial socket on top of case.
5. After screwing handle into the switch box, and seeing all loops coils compass etc. are handy the receiver should be checked for operation.
Having ascertained all is ready for operation, the setting of the compass can now be proceeded with.

SETTING OF COMPASS.

The procedure for setting of compass is as follows:-

Using large loop with sighting vanes, sight the two vanes on to some distant mark or stationary object until all three become in line.

Now take your prismatic compass and sight onto the same object and read the position of the object in respect to yourself through the prism. Next return to the D.F. unit, and checking your sight set the D.F. compass to the reading of the prismatic compass + 90°.

To know which pointer to read from, it is understood the operator knows the general direction of North from his prismatic compass and will not read off the incorrect pointer and get a 180° error. It is usually desirable to select another point in some other direction and with the same procedure recheck your D.F. compass.

POINTS TO NOTE.

1. When making sight use a stationary object appearing as thin as the sighting vane if possible.
2. The greater the distance of the object sighted on, the greater the accuracy.

3. When sighting with the prismatic compass stand away from magnetic field of speaker, metal case or other metal object that may influence this compass, but always stand in line with the D.F. unit and the sighting object to reduce error.
4. Remember the sight bearing is 90° from the pointer indication on the D.F. compass and may be either plus or minus. The operator should set the D.F. compass in the direction where north points in a north direction.

Example: Taking bearing with prismatic compass read say 32°
Taking loop sight, your pointer should read $32 + 90^{\circ} = 122^{\circ}$,
and the reciprocal pointer should read $32 + 90^{\circ} + 180^{\circ} = 302^{\circ}$,
also the north should point in northerly direction.

.....

Having taken the sight and set the D.F. compass all is ready to use as a Direction Finder. The D.F. compass should not be moved and will not have to be reset unless the case or scale is shifted.

SEARCH AND AERIAL SELECTION.

While searching for signal the receiver is operated in the normal manner and if in the field the telescopic is used as aerial. This is selected by the aerial switch which should be set on vertical.

On this position the receiver operates as normal receiver with full A.V.C.; or no A.V.C. with beat frequency oscillator operating as selected on the B.F.O. - A.V.C. switch of receive. Also the vertical aerial is switched in or single wire aerial connected to A1 may be used. A2 becomes grounded by the switch. If a doublet or 2 wire aerial is used connect to A1 and A2 and switch to doublet with aerial switch. In this position an open balanced aerial input is available for transmission line or doublet feeders.

TAKING BEARING.

With loop covering the frequency required inserted, locate signal on search aerial then switch to D.F. on aerial selector switch and relocate signal, swing loop to get best input.

With sense switch in D.F. position and having located signal with loop, rotate until minimum signal appears on meter, or minimum signal is heard in phones or speaker if used on c.w. in conjunction with the B.F.O. Read bearing on red pointer e.g. say 32° . Check if possible by rotating loop 180° and again read, where it should read $32^{\circ} + 180 = 212^{\circ}$. Now you have the bearing and it is either 32° or 212° from North. All that is required now is to take sense bearing.

Should the bearing and the reciprocal differ for some reason the bearing should be regarded with doubt and $\frac{1}{2}$ the difference of bearings considered as true bearing E.g. Bearing 32° and reciprocal 212° 1st reading. Bearing 36° reciprocal 216° 2nd reading. True bearing would be 34° and 214° .

This class of bearing may be used where signals are weak and no definite minimum is perceptible. These are classed as swing bearings and should be quoted as such.

Swing bearings are also those where no definite minimum is observed at one point, but perhaps over several degrees. If the centre of these minimum degrees is taken as bearing this should be near true bearing.

Points to Note.

1. Remember bearings are subject to errors especially as the frequency and distance is increased. The bearings at high frequencies even after 1 or 2 megacycles are subject to errors arising from horizontally - polarized waves. Refer to book Wireless Direction Finding by R. Keen B. Eng.
2. Swing bearings are doubtful and should be quoted as swing bearings.
3. Always see Aerial selector and sense switch are in D.F. position before taking bearing.

SENSE BEARING.

Having taken true bearing and noted readings of pointer and reciprocal say 32° and 212° it is required to know in which of these is the true bearing.

Switch in sense (with sense switch) and rotate loop 90° . Adjust sense phasing until a dip or reduction of signal is noted. If the dip is not present rotate 180° and adjust again. Check by rotating back and forth. It is in the direction of the red

SIDE of the loop that the signal is coming from when the signal is the strongest and the direction of the green side of the loop that the signal is coming from when the signal is weakest (where the phasing dip appears). E.g. Bearing = 32° red pointer, and 212° green pointer Switch in sense; Rotate until red side of loop faces approx 32° and green 212°. Adjust phasing control for dip - if the dip is present 212° is true bearing. If max signal is present read 32° as true bearing.

Remember the red side of the loop is the + side and the green is the - side of the cardioid.

DESCRIPTION OF D.F. UNIT.

NO. TYPE K/CR/11 DF.

POWER INPUT. 12 Volts D.C. 56 watts
230 Volts 40 - 50 cycles 72 watts.

FREQUENCY OF LOOPS.

Loop No.	frequency range.
1	130 - 900 Kc
2	900 - 4500 Kc
3	4 Mc - 25 Mc

LOOP SWITCH.

This switch changes the resonance of the loop by series and parallel of the two windings in the loop. As the change is over small bands calibration is less practical than experiment in the field. An indication of change is as follows:

Loop No.	Switch position	frequency range.
1	1	130 - 300 Kc
1	2	280 - 370 "
1	1	370 - 600 "
1	2	600 - 800 "
1	1	800 - 900 "
1	2	900 - 1250 "
1	1	1250 - 1800 "
2	1	900 - 1100 "
2	2	1100 - 1500 "
2	1	1500 - 2000 "
2	2	2000 - 45,000 "
3	1	4000 - 6000 "
3	2	6000 - 24,000 "

It should be noted that the loops have a good extended frequency range before serious losses are incurred.

POWER OUTPUT.

Speaker. 1750 ohms 2 watts. See circuit fig. 7b.

KINGSLEY - COMMUNICATION RECEIVER TYPE K/CR/II D.F.

4 MAY 1942

W.D. & H.O. WILLS

1.

AERIAL

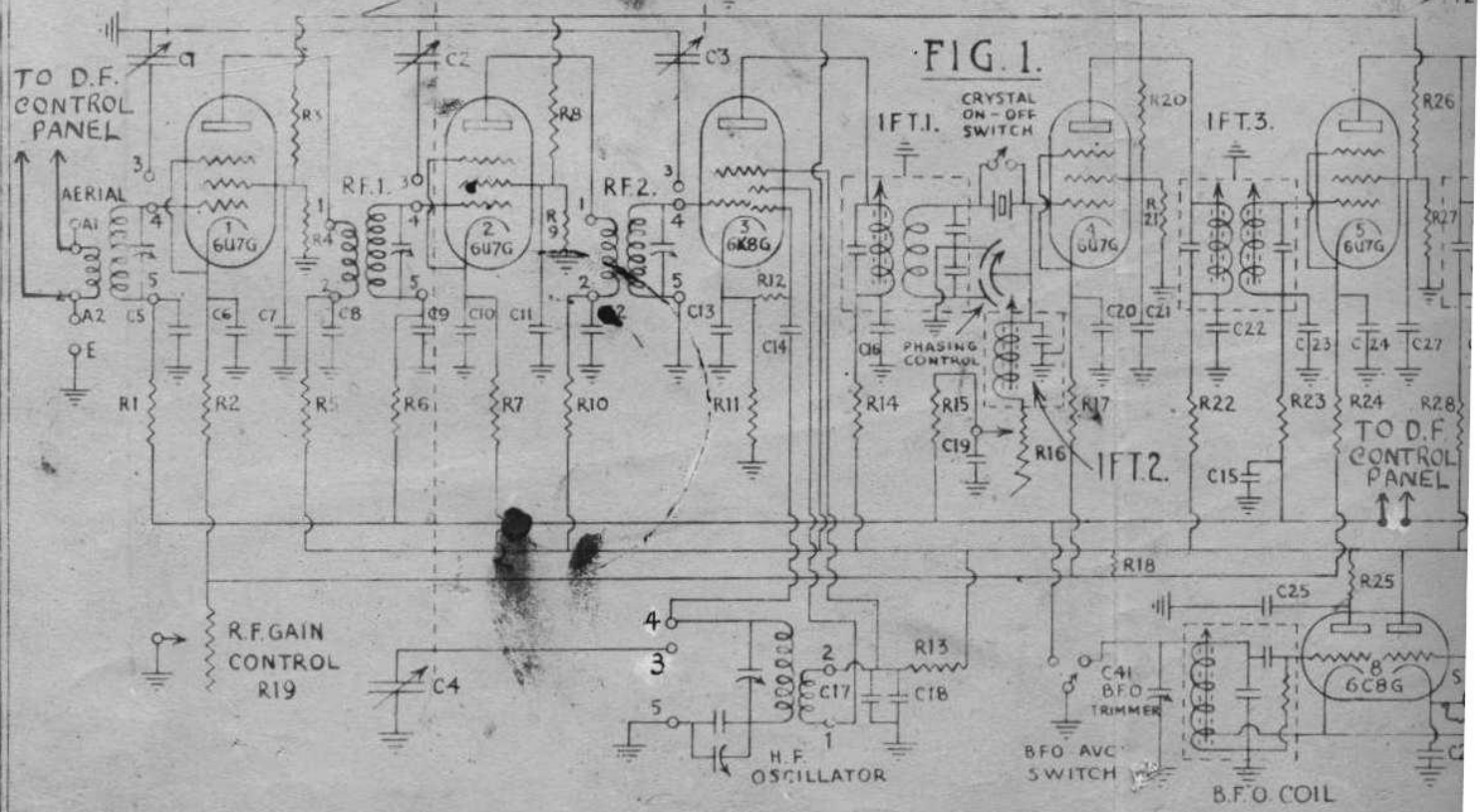
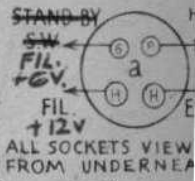
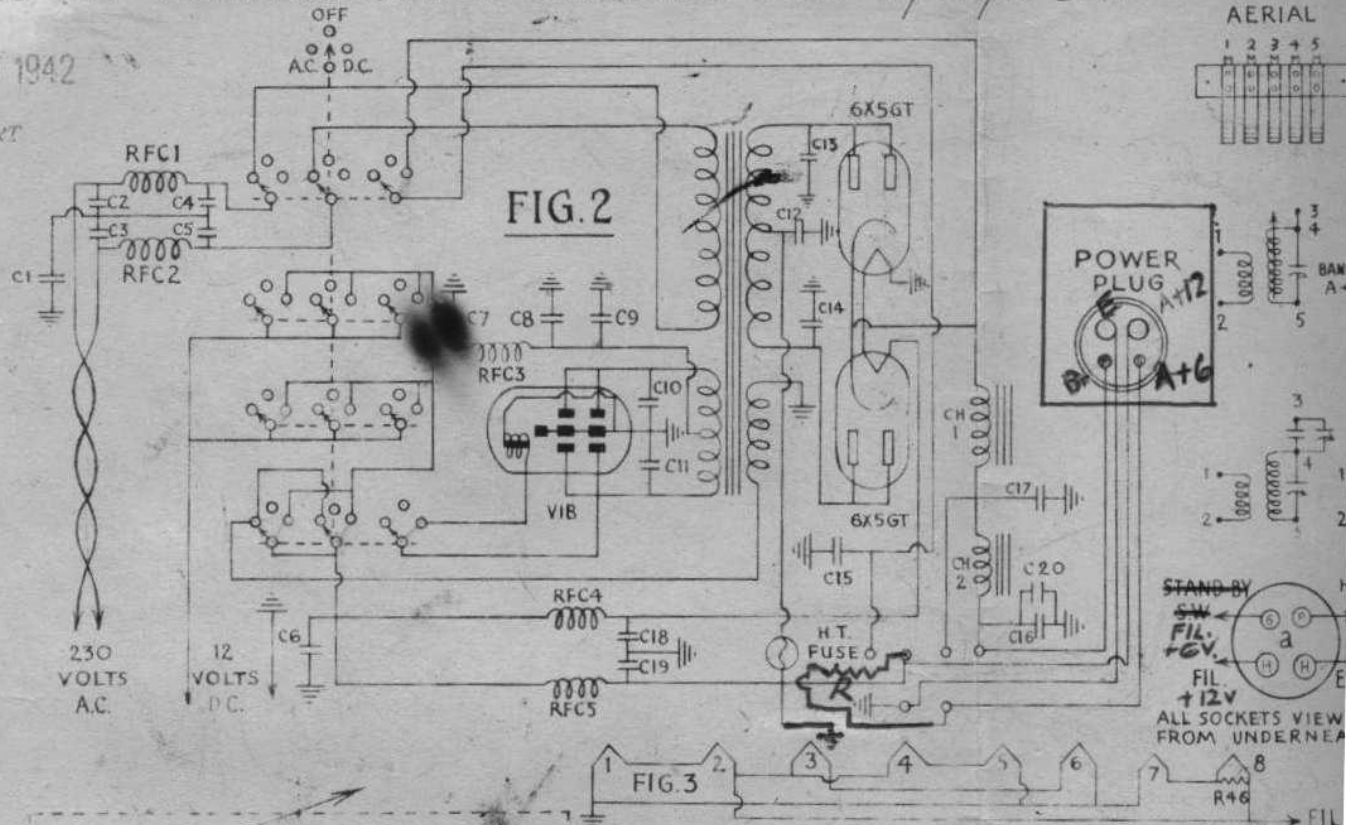

COMMUNICATION RECEIVER TYPE K/CR/II D.F.

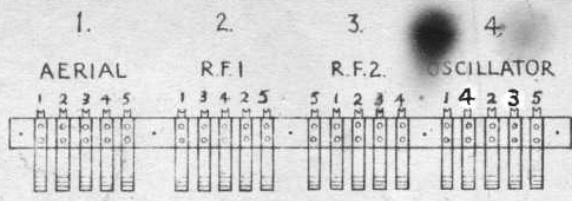
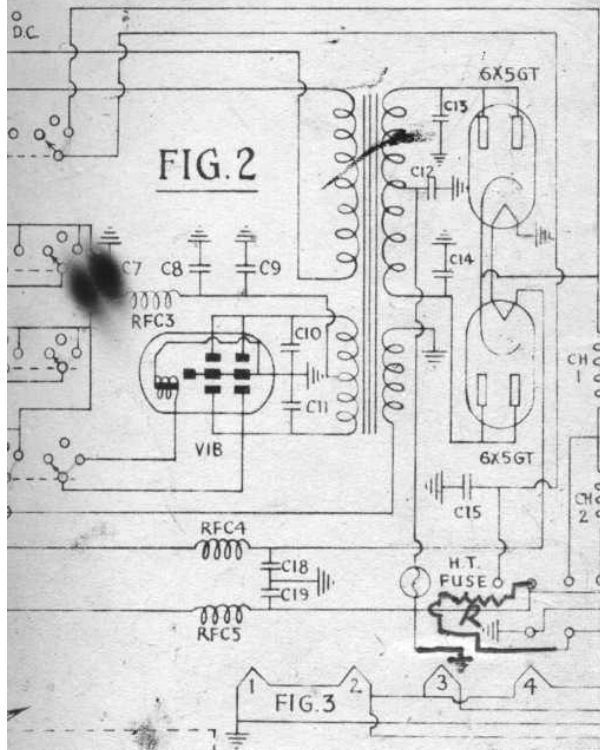
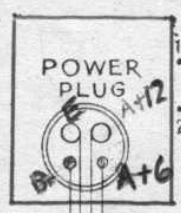

FIG. 4.



BANDS A.B.C.D.

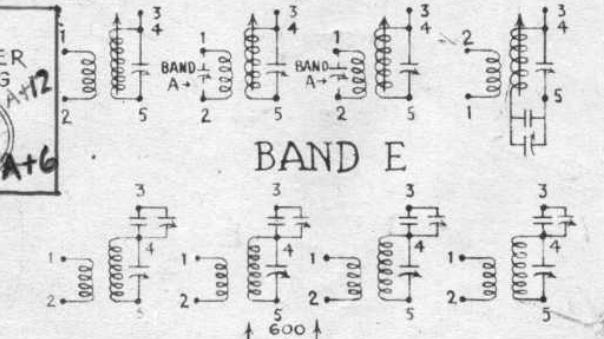

FIG. 5.

BAND E

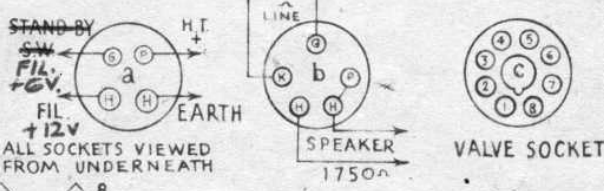

FIG. 6.

FIG. 7.

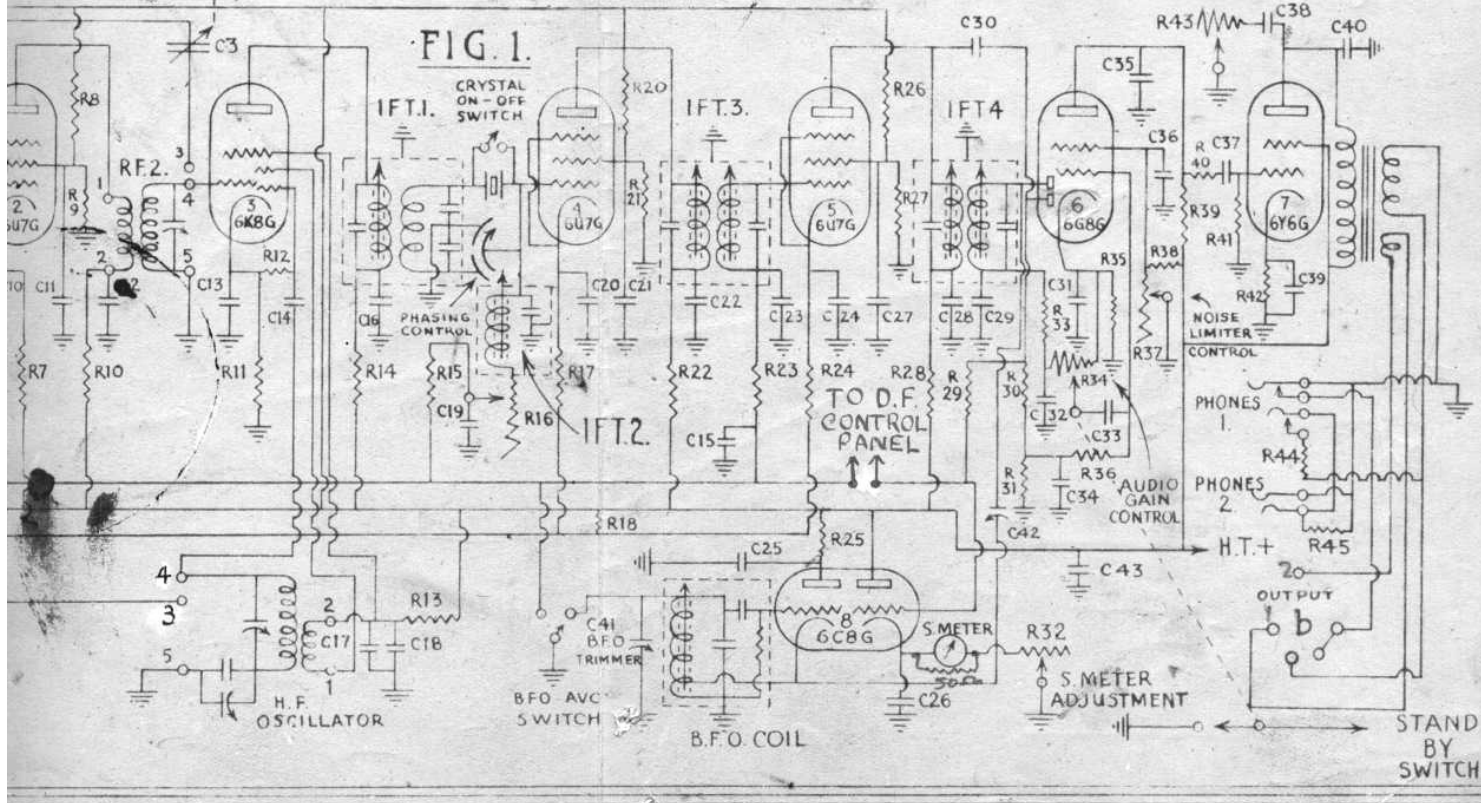
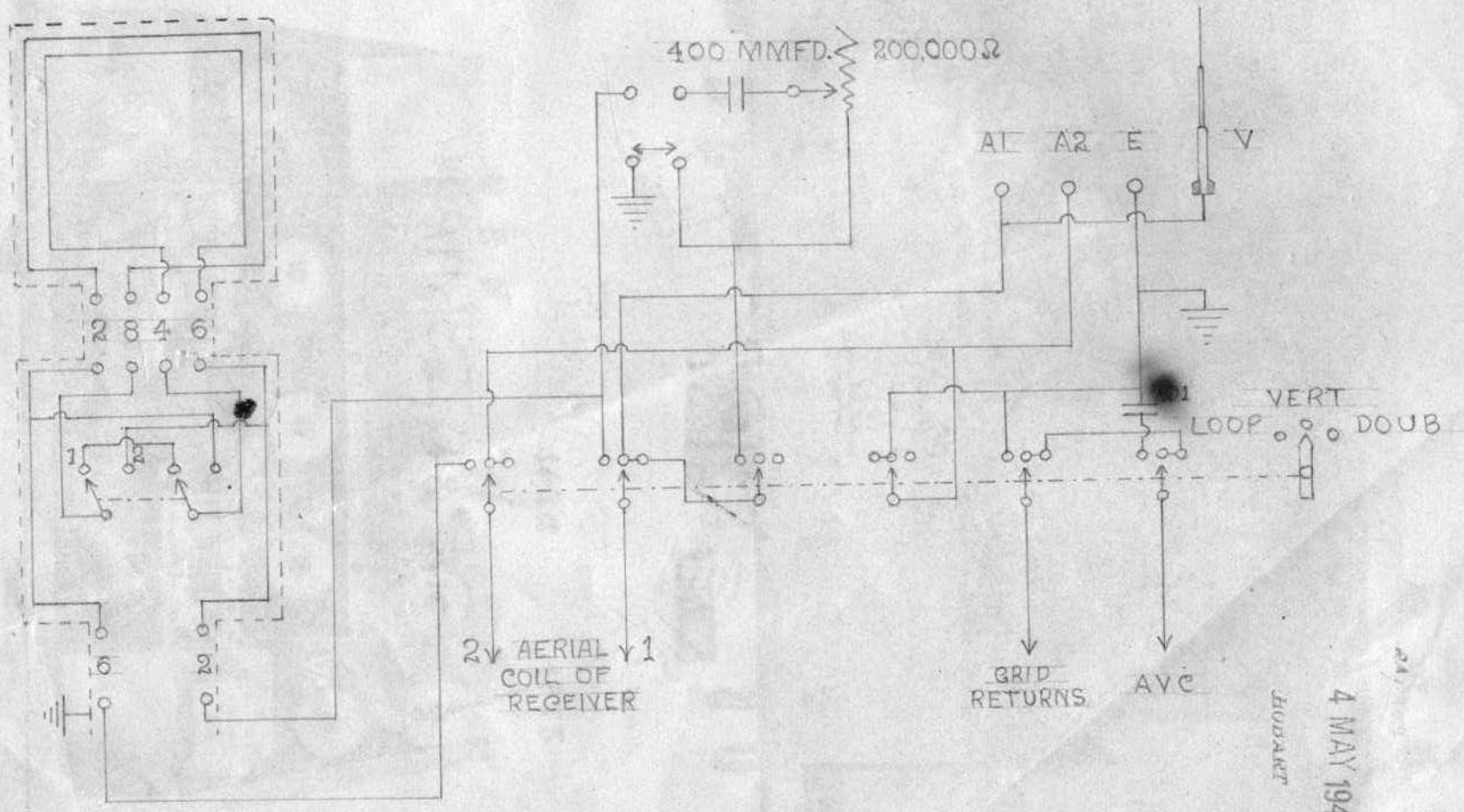

FIG. 1.

STAND BY SWITCH

SCHEMATIC DIAGRAM OF D.F. CONTROL PANEL



HODART

4 MAY 1942

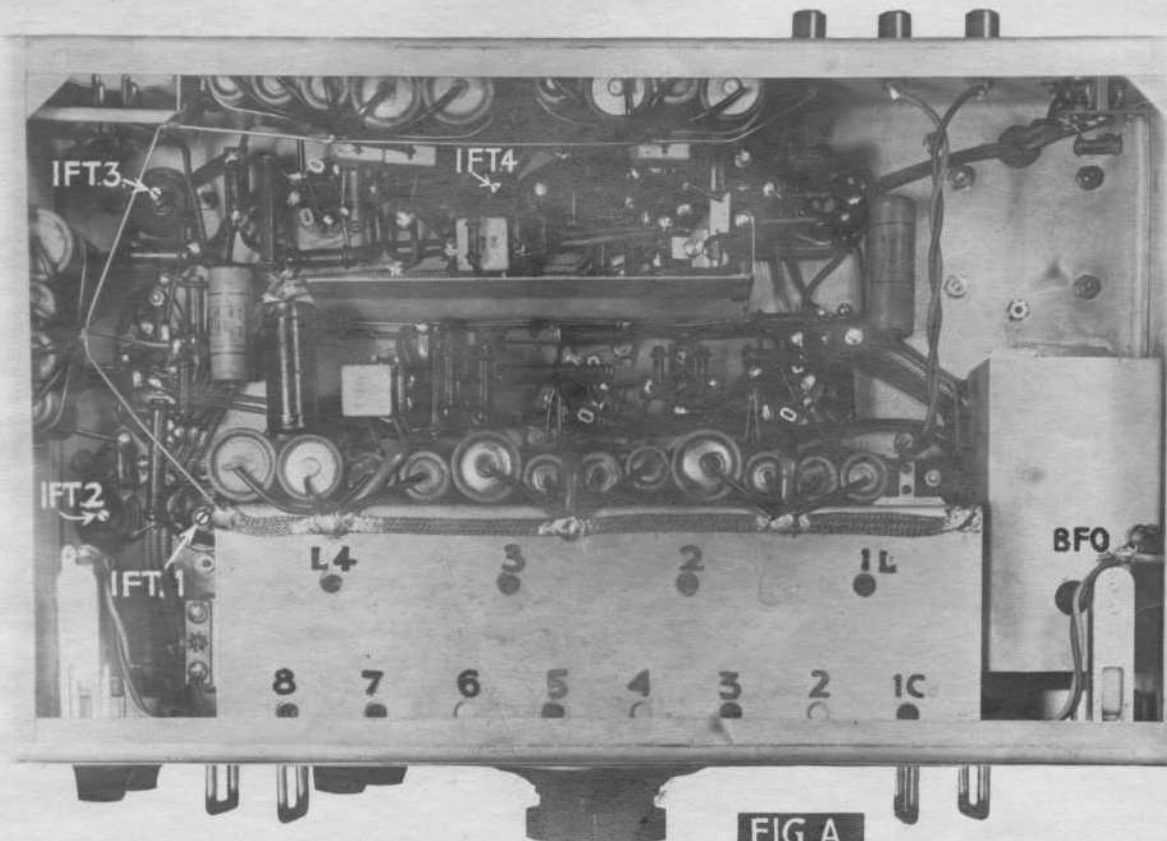

FIG. A.

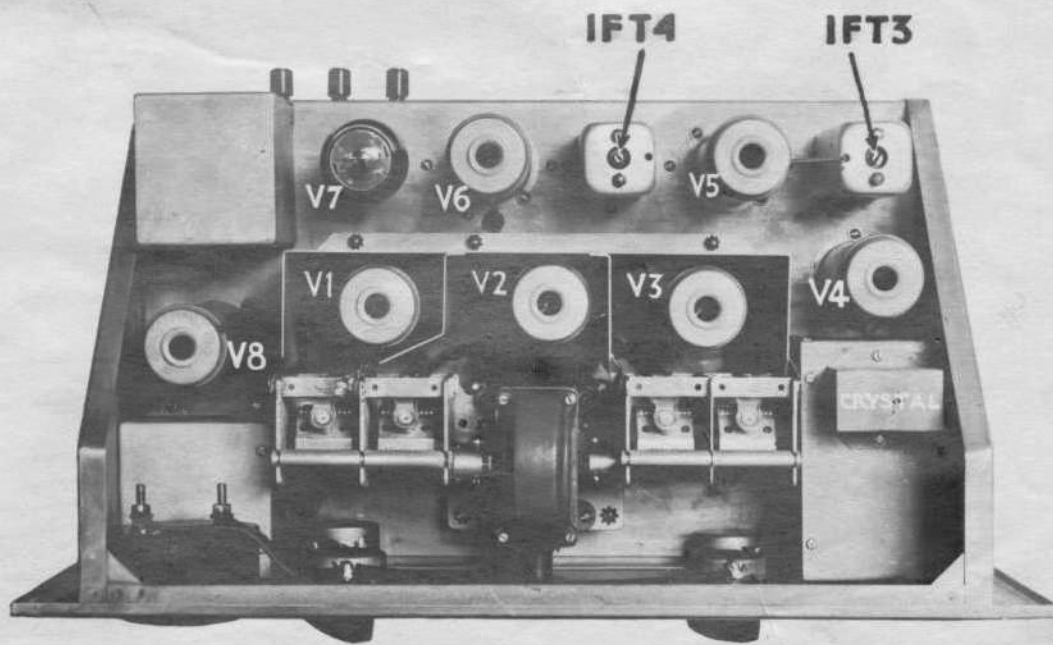

FIG. B.