

INSTRUCTION BOOK



75A-2



COLLINS AMATEUR EQUIPMENT GUARANTEE

The Collins Amateur equipment described herein is sold under the following guarantee:

Collins agrees to repair or replace, without charge, any equipment, parts, or accessories which are defective as to design, workmanship, or materials, and which are returned to Collins at its factory, transportation prepaid, provided:

- (a) Buyer has completed and returned to Collins promptly following his purchase the Registration Card included in the Instruction Book furnished with the equipment.
- (b) Notice of the claimed defect is given Collins within 90 days from the date of purchase and goods are returned in accordance with Collins' instructions.
- (c) Equipment, accessories, tubes, and batteries not manufactured by Collins or from Collins' designs are subject to only such adjustments as Collins may obtain from the supplier thereof.
- (d) No equipment or accessory shall be deemed to be defective if, due to exposure or excessive moisture in the atmosphere or otherwise after delivery, it shall fail to operate in a normal and proper manner.
- (e) Any failure due to use of equipment in excess of that contemplated in normal amateur operations shall not be deemed a defect within the meaning of these provisions.

The guarantee of these paragraphs is void if equipment is altered or repaired by others than Collins or its authorized service center.

No other warranties, expressed or implied, shall be applicable to said equipment, and the foregoing shall constitute the Buyer's sole right and remedy under the agreements contained in these paragraphs. In no event shall Collins have any liability for consequential damages, or for loss, damage or expense directly or indirectly arising from the use of the products, or any inability to use them either separately or in combination with other equipment or materials or from any other cause.

IMPORTANT! It is necessary that the business reply card included herewith be filled out and mailed to the Company promptly in order for this guarantee to be effective.

HOW TO RETURN MATERIAL OR EQUIPMENT. If, for any reason, you should wish to return material or equipment, whether under the guarantee or otherwise, you should notify us, giving full particulars including the details listed below, insofar as applicable. If the item is thought to be defective, such notice must give full information as to nature of defect and identification (including part number if possible) of part considered defective. (With respect to tubes we suggest that your adjustments can be speeded up if you give notice of defect directly to the tube manufacturer.) Upon receipt of such notice, Collins will promptly advise you respecting the return. Failure to secure our advice prior to the forwarding of the goods or failure to provide full particulars may cause unnecessary delay in handling of your returned merchandise.

ADDRESS:

Collins Radio Company
Sales Service Department
Cedar Rapids, Iowa

INFORMATION NEEDED:

- (A) Type number, name, and serial number of equipment
- (B) Date of delivery of equipment
- (C) Date placed in service
- (D) Number of hours of service
- (E) Nature of trouble
- (F) Cause of trouble if known
- (G) Part number (9 or 10 digit number) and name of part thought to be causing trouble
- (H) Item or symbol number of same obtained from parts list or schematic
- (I) Collins' number (and name) of unit sub-assemblies involved in trouble
- (J) Remarks

HOW TO ORDER REPLACEMENT PARTS. When ordering replacement parts, you should direct your order as indicated below and furnish the following information insofar as applicable. To enable us to give you better replacement service, please be sure to give us complete information.

ADDRESS:

Collins Radio Company
Sales Service Department
Cedar Rapids, Iowa

INFORMATION NEEDED:

- (A) Quantity required
- (B) Collins' part number (9 or 10 digit number) and description
- (C) Item or symbol number obtained from parts list or schematic
- (D) Collins' type number, name, and serial number of principal equipment
- (E) Unit sub-assembly number (where applicable)

INSTRUCTION BOOK
for
75A-2 AMATEUR RECEIVER

Manufactured By
COLLINS RADIO COMPANY, Cedar Rapids, Iowa

520 9482 00
June 21, 1952

ADDENDA 75A-2

Paragraph 5.3.2. a. 1. reads: Connect the lead of the signal generator to pin No. 1 of V7, etc. Correct this to read "pin No. 7 of V4."

The alignment table on page 5-4 should be corrected as follows:

"RF Capacitor" column	"Ant. Capacitor" column
Change C18 to C22	Change C1 to C5
C19 to C23	C2 to C7
C20 to C24	C3 to C8
	C4 to C9

August 20, 1952

Manufactured By

COLLINS RADIO COMPANY, Cedar Rapids, Iowa

TABLE OF CONTENTS

<u>Paragraph</u>	<u>Page</u>
<u>SECTION I - GENERAL DESCRIPTION</u>	
1.1. General	1-1
1.2. Description	1-1
1.2.1. Frequency Coverage	1-1
1.2.2. Bandspread	1-1
1.2.3. Accuracy and Stability	1-1
1.2.4. Image and I-F Rejection	1-2
1.2.5. Sensitivity and Signal To Noise Ratio	1-2
1.2.6. Selectivity	1-2
1.2.7. Phasing	1-2
1.2.8. Automatic Noise Limiter	1-2
1.2.9. CW-Noise Limiter	1-2
1.2.10. Automatic Volume Control	1-2
1.2.11. Signal Strength Meter	1-2
1.2.12. Audio Output	1-2
1.2.13. Terminal Impedances	1-2
1.2.14. Controls	1-3
1.2.15. Circuit	1-3
1.2.16. Tube Complement	1-3
1.2.17. Power Source	1-4
1.2.18. Dimensions - Cabinet	1-4
1.2.19. Weight	1-4
1.2.20. Finish	1-4
1.3. Accessories	1-4
1.3.1. Speaker Type	1-4
1.3.2. Headphones	1-4
1.3.3. Antenna	1-4
1.3.4. Crystal Calibrator	1-4
1.3.5. NBFM Adaptor, Type 148C-1	1-4
<u>SECTION II - INSTALLATION</u>	
2.1. Unpacking	2-1
2.2. Connections	2-1
2.2.1. Antenna and Ground	2-1
2.2.2. Coaxial Conversion	2-1
2.2.3. Output Connections	2-2
2.2.4. Standby	2-2
2.2.5. CW Break-In	2-2
2.2.6. Power	2-3
2.3. Fuse	2-3
2.4. Installation of 148C-1 NBFM Adaptor Unit	2-3
2.5. Installation of 8R-1 Calibrator Unit	2-3

TABLE OF CONTENTS

<u>Paragraph</u>	<u>Page</u>
<u>SECTION III - ADJUSTMENT AND OPERATION</u>	
3.1. Initial Adjustments	3-0
3.1.1. "S" Meter	3-0
3.2. Operation	3-0
3.2.1. Function of Controls	3-0
3.2.2. Operating Practices	3-2

SECTION IV - CIRCUIT DESCRIPTION

4.1. Mechanical	4-0
4.2. General	4-0
4.3. Tuning	4-0
4.4. Band Switching	4-0
4.5. Electrical Theory	4-0
4.5.1. Circuit	4-0
4.5.2. Tuning	4-1
4.5.3. Crystal Filter	4-3
4.5.4. Noise Limiter	4-3
4.5.5. CW Noise Limiter	4-4
4.5.6. Automatic Volume Control	4-4
4.5.7. Audio Amplifier	4-5
4.5.8. 148C-1 Narrow Band Frequency Modulation Adaptor	4-5
4.5.9. 8R-1 Calibrator Unit	4-5

SECTION V - MAINTENANCE

5.1. Trouble Shooting	5-0
5.2. Fuses	5-0
5.3. Alignment	5-0
5.3.1. Equipment and Tools Used for Alignment	5-0
5.3.2. 455 kc I.F. Alignment	5-0
5.3.3. Alignment of BFO	5-1
5.3.4. Adjustment of Crystal Oscillator	5-2
5.3.5. Variable I.F. Alignment	5-3
5.3.6. 2.5 - 1.5 MC I.F. Alignment	5-3
5.3.7. 5.455 - 3.455 MC I.F. Alignment	5-3
5.3.8. Tweet Trap Adjustment	5-4
5.3.9. R. F. Alignment	5-4
5.3.10. VFO Adjustment	5-5
5.4. Dial Cords	5-5
5.4.1. General	5-5
5.4.2. Front Panel Removal	5-5
5.4.3. Pointer Cord	5-6
5.4.4. Drum Cord	5-6

LIST OF ILLUSTRATIONS

<u>Figure</u>	<u>Title</u>
1-1	75A-2 Front View and Block Diagram
3-1	75A-2 Operating Controls
4-1	Frequency V. S. Dial Division Table
4-2	Block Diagram of Tuning Circuits
4-3	Noise Limiter Circuits
4-4	AVC Circuit
5-1	75A-2 Alignment Adjustments
5-2	Dial Cord Drawing
5-3	75A-2 Top View
5-4	75A-2 Bottom View
5-5	75A-2 Amateur Receiver
5-6	148C-1 NBFM Adaptor Schematic Diagram
5-7	8R-1 Crystal Calibrator Schematic Diagram
5-8	Assembling Plug UG-21B/U to cable RG-8/U

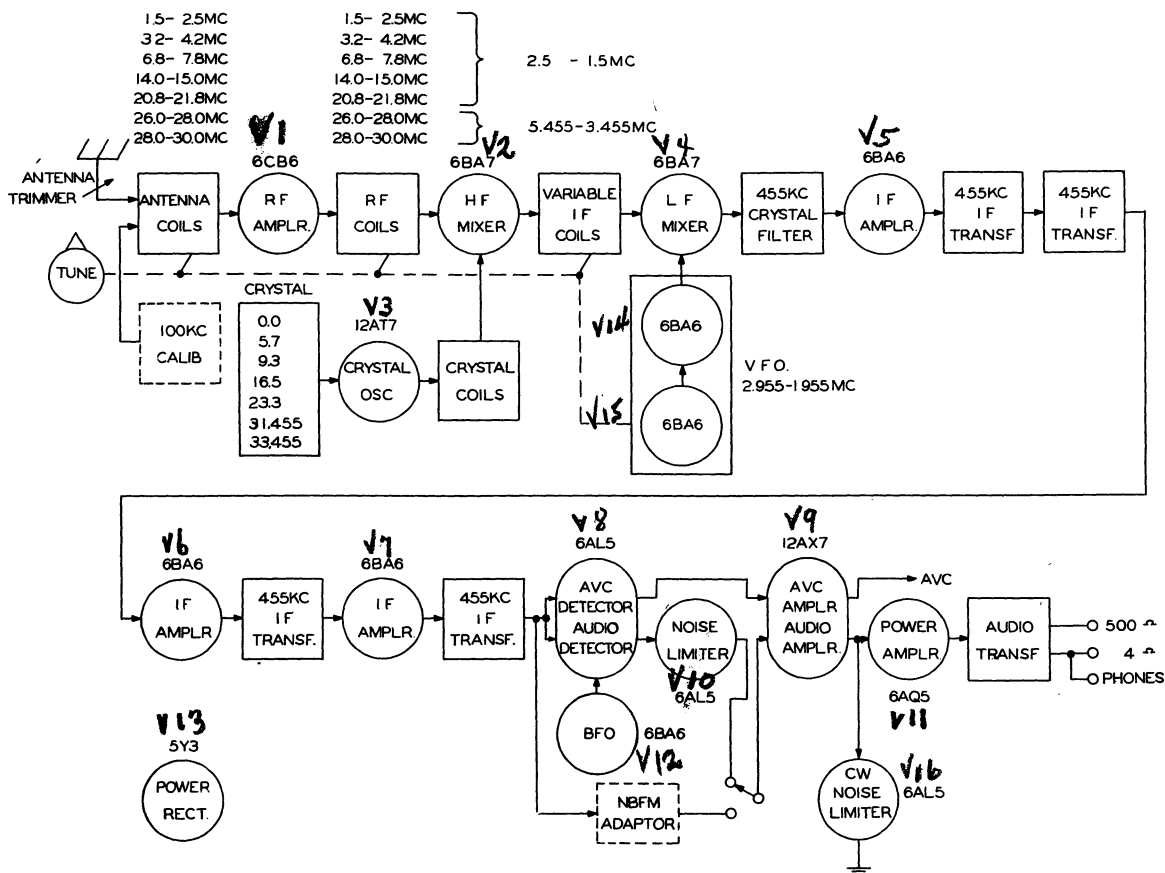

Figure 1-1. 75A-2 Front View and Block Diagram

SECTION I

GENERAL DESCRIPTION

1.1. GENERAL.

The Collins Model 75A-2 Receiver is designed for the amateur bands in the frequency range of 1500 kc to 30 mc. The receiver provides facilities for the reception of CW, MCW, and AM PHONE reception. Two octal sockets have been provided for internal plug-in attachment of a Narrow Band Frequency Modulation Detector unit and a Crystal Calibrator unit which provides reference frequencies every 100 kc. Controls for these accessories are provided on the front panel and are wired ready to use. The receiver uses the double-conversion superheterodyne principal to obtain high image rejection. Stability is obtained by the use of quartz crystals in the high frequency oscillator stage and a Collins Type 70E-12 sealed VFO in the low frequency oscillator circuit. Additional features of the receiver are separate noise limiters for PHONE and CW, amplified AVC, crystal filter, direct reading dial with frequency readings accurate to within 1 kc up to 21.8 mc and 2 kc from 26 to 30 mc. Provision has been made to connect a blocking bias to the receiver to mute the receiver audio when the key of an associated transmitter is closed.

1.2. DESCRIPTION.

1.2.1. FREQUENCY COVERAGE, - The amateur bands are covered as follows:

160 meters - 1.5 - 2.5 mc	15 meters - 20.8 - 21.8 mc
80 meters - 3.2 - 4.2 mc	11 meters - 26.0 - 28.0 mc
40 meters - 6.8 - 7.8 mc	10 meters - 28.0 - 30.0 mc
20 meters -14.0 -15.0 mc	

The above table shows the tuning ranges within which the amateur bands fall. The exact frequencies of the amateur bands are given in the latest amateur radio handbooks.

1.2.2. BANDSPREAD, - The permeability tuning system employed in the 75A has been engineered to give linear tuning on each band. Ten turns of the vernier tuning dial cover each of the individual ranges shown above. Each division of the vernier tuning dial (which has 100 divisions) represents 1 kc on the 160, 80, 40, 20, and 15 meter bands, and 2 kc on the 11 and 10 meter bands.

1.2.3. ACCURACY AND STABILITY, - Visual tuning accuracy to within 1 kc from 1.5 mc to 21.8 mc and 2 kc from 26 mc to 30 mc provided the vernier dial corrector (zero set control) is exactly calibrated at the centers of each tuning range. Extreme variation in plate supply voltage causes a change of only a few cycles in the CW note. Furthermore, the CW note is absolutely independent of all

except the tuning controls. Physical shock will not disturb the frequency unless the shock is severe enough to change the dial settings. The stability is available after a very short warm up.

1.2.4. IMAGE AND I-F REJECTION. - The circuit design of the 75A receiver has inherently high rejection to spurious frequencies. Image rejection is a minimum of 50 db. I-F rejection is 50 db minimum.

1.2.5. SENSITIVITY AND SIGNAL TO NOISE RATIO. - A 6 db signal to noise ratio and one watt of audio output is obtained with signal inputs of 2 microvolts or less.

1.2.6. SELECTIVITY. - The crystal filter controls provide a bandwidth that is variable in 5 steps from approximately 4 kc to 200 cycles at 2 times down (6 db down from the peak of the resonant frequency). There is only slight loss in gain caused by use of the crystal filter with the exception of the extremely sharp position which gives about 6 db loss. The fixed I-F selectivity provides a bandwidth of approximately 13 kc at 1000 times down (60 db down from the peak of the resonant frequency).

1.2.7. PHASING. - The crystal filter includes a phasing control which provides a rejection notch for suppressing heterodynes. The range of rejection of this control has been extended downward to 250 cps or lower.

1.2.8. AUTOMATIC NOISE LIMITER. - The 75A receiver contains a series type noise limiter which automatically adjusts its limiting threshold to all carrier levels.

1.2.9. CW-NOISE LIMITER. - A shunt type noise limiter with front panel control of limiting level is provided for CW operation.

1.2.10. AUTOMATIC VOLUME CONTROL. - Delayed, amplified AVC gives constant output within 6 db for a change in r-f input from 5 microvolts to 0.5 volt. AVC is applied to the r-f stages and three i-f stages. The proper amount of AVC delay is employed for maximum sensitivity on weak signals.

1.2.11. SIGNAL STRENGTH METER. - The S meter is calibrated from 1 to 9 in steps of approximately 6 db each, and for 20, 40, and 60 db above S9. Zero adjustment is provided. A reading of S9 is obtained with an input of approximately 100 microvolts. The AVC amplifier tube works into an unusually low value of load impedance which permits quick recovery from noise pulses or strong signals from the associated transmitter, thus allowing fast break-in when the receiver is used to monitor operation of the transmitter.

1.2.12. AUDIO OUTPUT. - 2.5 watts of audio power are available.

1.2.13. TERMINAL IMPEDANCES.

- a. INPUT - The antenna input circuit is designed for a nominal 50 to 150 ohms

impedance but will accommodate a wide variety of antenna impedances, both balanced and unbalanced, without serious loss. Mounting holes for an Army type SO 239 coaxial connector are provided to allow convenient connection to coaxial transmission lines, such as RG-8/U (52 ohms) and RG-11/U (73 ohms).

b. OUTPUT. - A 500 ohm output and two 4 ohm outputs (one of which is interlocked with the panel headphone jack) is available on a rear terminal board. The panel headphone jack is a four ohm termination so that any value of headphone impedance will function satisfactorily.

1.2.14. CONTROLS. - The following controls are on the front panel of the receiver:

Tuning Control	RF Gain Control
Band Switch	Audio Gain Control
CW Pitch Control	Crystal Phasing Control
Antenna Trim Control	CW-AM-FM Switch
Off-Standby-On Switch	Noise Limiter-Calibrate Switch
Crystal Selectivity Switch	Zero Set for Tuning Control
Headphone Jack	CW Limiter Control

1.2.15. CIRCUIT. - Dual Conversion superheterodyne. One r-f amplifier stage, 1st mixer stage, crystal controlled h-f oscillator, variable i-f filter, 2nd mixer, three fixed i-f amplifier stages, detector/AVC Rectifier stage, two audio amplifier stages, AVC amplifier/noise limiter stage, CW noise limiter, variable frequency oscillator, beat frequency oscillator, and power supply. All circuits concerned with the tuning process are permeability tuned and ganged to one control.

1.2.16. TUBE COMPLEMENT. -

<u>SYMBOL</u>	<u>TUBE TYPE</u>	<u>FUNCTION</u>
V-1	6CB6	RF Amplifier
V-2	6BA7	First Mixer
V-3	6BA7	Second Mixer
V-4	12AT7	Crystal Oscillator
V-5	6BA6	455 kc IF Amplifier
V-6	6BA6	455 kc IF Amplifier
V-7	6BA6	455 kc IF Amplifier
V-8	6AL5	Detector and AVC Rectifier
V-9	12AX7	AVC Amplifier and AF Amplifier
V-10	6AL5	Automatic Noise Limiter
V-11	6AQ5	Audio Power Amplifier
V-12	6BA6	Beat Frequency Oscillator
V-13	5Y3GT	Power Rectifier
V-14	6BA6	Variable Frequency Oscillator
V-15	6BA6	VFO Isolation
V-16	6AL5	CW Noise Limiter
V-17	0A2	Voltage Regulator

1.2.17. POWER SOURCE. - Power supply self-contained. Requires 115 volt 50/60 cps source. Power consumption about 85 watts.

1.2.18. DIMENSIONS. - CABINET. - 21-1/8" wide, 12-1/2" high, 13-1/6" deep. The receiver chassis is mounted on a standard 10-1/2" x 19" panel and can be removed from the cabinet and mounted in a standard relay rack. Depth behind the panel is 13-5/16".

1.2.19. WEIGHT. - 50 lbs.

1.2.20. FINISH. - St. James Gray wrinkle.

1.3. ACCESSORIES.

1.3.1. SPEAKER TYPE 270G-2. - An external 10 inch speaker, not furnished, is available, mounted in a matching cabinet. The speaker cabinet measures 15" wide, 11-1/8" high, and 9-1/8" deep overall. Weight 15 lbs.

1.3.2. HEADPHONES. - Any good headphones may be used. The 4 ohm receiver output impedance provides sufficient signal level for low or high impedance headphones.

1.3.3. ANTENNA. - Any good antenna may be used; however, the receiver input circuit is designed for antenna impedances in the order of 50 to 150 ohms. In most cases, the transmitting antenna will also be the best choice for receiving. Connections on the rear permit the use of both balanced and unbalanced lines. Mounting holes have been provided for installing a Coaxial connector. This allows advantage to be taken of the low noise pickup of coaxial transmission lines.

1.3.4. CRYSTAL CALIBRATOR. - The type 8R-1 Crystal Calibrator is available on order. The 100 kc crystal oscillator in this unit provides reference frequencies every 100 kc. This unit plugs into a socket within the receiver. Operating voltages and controls are provided in the receiver.

1.3.5. NBFM ADAPTOR, TYPE 148C-1. - This unit is also available on order. With it, narrow band FM signals can be detected and fed through the receiver audio circuits. This unit also plugs into a socket within the receiver. Operating voltages and controls are provided in the receiver.

SECTION II

INSTALLATION

2.1. UNPACKING.

The model 75A receiver is packed in heavy cartons. Refer to the packing slip for a list of all equipment supplied. Open packing cartons carefully to avoid damage to the units within. Remove the packing material and carefully lift the units out of the cartons. Search all of the packing materials for small packages. Inspect each unit for loose screws and bolts. Be certain all controls such as switches, dials, and so forth, work properly. All claims for damage should be filed promptly with the transportation company. If a claim is to be filed, the original packing case and material must be preserved. See the instructions on the back of the bill of lading.

2.2. CONNECTIONS.

2.2.1. ANTENNA AND GROUND. - The antenna connector strip is located at the right hand side of the chassis rear wall (viewed from the rear). Balanced antennas should be connected to terminals 1 and 2. Unbalanced antennas should be connected to terminals 1 and G with terminal 2 jumpered to terminal G. Connect a good ground to terminal G for any type of antenna installation.

2.2.2. COAXIAL CONVERSION. - To convert the receiver for coaxial line antenna input, remove the receiver from the cabinet, unsolder the wires from the rear of the antenna terminal strip and remove the strip. Remove the small plate adjacent to the antenna terminal strip and bolt it in place of the terminal strip. The holes exposed in the chassis when the plate was removed are correct for Collins 357 9005 00 (Army type SO 239, Amphenol 83-1R) socket (not furnished). The mating plug is a Collins 357 9014 00 (Army PL-259, Amphenol 83-1SP) (not furnished). Receptacle UG-58/U (mating plug UG-21B/U) may also be used for coaxial conversion. Connect the wire taken from terminal number 2 to the shell of the coaxial socket and the wire taken from terminal 1 to the center pin of the coaxial socket. The receiver may now be used with RG-8/U or similar 52 ohm coaxial line. The external ground can be connected to the "G" terminal of the audio or muting terminal strips.

CAUTION

Do not subject the input circuits to r-f voltages in excess of 50 volts. Excessive r-f voltages may be encountered if the receiving antenna is not disconnected when the transmitter is operating. Capacity coupling through the antenna change-over relay

may also result in excessive r-f voltage when the transmitter is operating. It is recommended that a relay be used to ground antenna terminals 1 and 2 directly to the receiver chassis with short leads when the transmitter is operating. This precaution should be taken if the transmitter signal is sufficient to light a 1/4 watt neon tube at the receiver antenna terminals.

2.2.3. OUTPUT CONNECTIONS. -

a. **SPEAKER** - Viewing the receiver from the rear, the output connections are at the left hand edge of the chassis. Terminals G and 4 are intended for the 4 ohm voice coil in the Type 270G-2 speaker. This connection is interlocked with the phone jack on the front panel to turn the speaker off when the headphones are plugged into the panel headphone jack.

b. **HEADPHONES** - In addition to the front panel headphone jack, a four ohm connection is provided at the rear terminal strip at terminals G and P to which headphones may be connected by those operators who wish to avoid having headphone wire on the operating table.

c. **500 OHM CONNECTION** - Terminals G and 500 provide a 500 ohm output connection which is useful for additional speakers and so forth. These also may be used for CW Sidetone input.

2.2.4. **STANDBY**. - A pair of terminals located at the rear of the chassis marked 1 and 2 (on the center terminal strip) is provided for connecting to relay contacts or other similar device for automatically disabling the receiver for break-in operation. These terminals are across a blocking bias resistor and are in parallel with contacts on the OFF-STANDBY-ON switch. If these connections are used, they will be operable when the switch is in the STANDBY position and shorted when the switch is in the ON position.

2.2.5. **CW BREAK-IN**. - Terminals M and G on the center terminal strip are provided to mute the receiver audio when the key of the associated transmitter is closed in cw operation. To use this feature a DC source which provides +20 volt minimum with the key closed and 0 voltage with the key open is required. The Collins 32V-1, 32V-2, and KW-1 transmitters provide this muting voltage. This +20 volt source may be taken from across the cathode resistor of a keyed stage that is biased to cut-off or may be taken from a resistor placed in series with the key of a cathode keyed stage. The resistor must be connected between key and ground. It may also be obtained from a battery in series with auxiliary contacts on a keying relay. If the first two methods are used, be sure and connect the G terminal of the receiver to the transmitter chassis ground. Connect the positive potential to the M terminal and the negative to the G terminal.

Note that the muting system does not provide protection to the input circuit to the receiver. See paragraph 2.2.2. for information covering input protection.

2.2.6. POWER. - The receiver is powered through a 5-1/2 foot, rubber covered, permanently attached service cord equipped with a standard plug. Connect this plug to a 115 volt 50/60 cps power source only.

2.3. FUSE.

The protective fuse for the receiver is contained within an extractor type fuse post located on the rear of the chassis near the left hand corner. To remove the fuse, turn the cap of the fuse post counterclockwise and pull straight out. Use only a 2 ampere fuse.

2.4. INSTALLATION OF 148C-1 NBFM ADAPTOR UNIT.

This unit plugs into the octal socket immediately behind the VFO. To install this unit, remove the receiver from its cabinet. Remove the snap button from the top of the receiver chassis. The hole thus uncovered provides access to the tuning core adjustment at the bottom of the discriminator transformer. Remove the two nuts from the spade bolts protruding from the bottom of the 418C unit, plug the unit into the adaptor socket and replace the nuts on the bottom of the spade bolts which will protrude from the bottom of the chassis. While the receiver is out of the cabinet, re-align both the NBFM unit and the last i-f transformer, T-7. See paragraph 5.3.2. in section V.

2.5. INSTALLATION OF 8R-1 CALIBRATOR UNIT.

This unit plugs into the octal socket located in the rear left hand corner of the receiver chassis. There are no mounting facilities other than the connector plug. Turn the receiver on after installation and after a warm up period, tune in some station (such as WWV) whose frequency accuracy is known and which falls on a multiple of 100 kc. Operate the LIMITER switch to the CAL position and check for zero beat (BFO off). It may be necessary to use a short antenna if the received signal is too strong. If a beat note is heard, adjust C-301 in the calibrator unit until zero beat is obtained. The ZERO SETTING knob can now be adjusted to put the hair line on calibration on any multiple of 100 kc.

SECTION III

ADJUSTMENT AND OPERATION

3.1. INITIAL ADJUSTMENTS.

3.1.1. "S" METER. - The "S" meter has a potentiometer for zero adjust on top of the chassis. To adjust, place the receiver in operation with the CW-AM-FM switch on AM. Set the RF GAIN CONTROL full clockwise, short the antenna input and adjust control for zero reading on the "S" meter.

3.2. OPERATION.

3.2.1. FUNCTION OF CONTROLS.

a. OFF-STANDBY-ON - This control knob controls the plate and filament power to the receiver. In the OFF position, the receiver is completely turned off. In the ON position, both filament and plate power are turned on. In the STANDBY position, the filaments are turned on but the plate power is disconnected from certain receiver circuits. If a receiver disabling relay is used with the transmitter, the OFF-STANDBY-ON switch should be placed in the STANDBY position. In this kind of operation, the receiver will be disabled every time the press-to-talk switch on the microphone is pressed but the signal can be monitored by turning the OFF-STANDBY-ON switch to the ON position if desired.

b. BAND CHANGE - The BAND CHANGE switch, located at the left of the tuning dial selects the amateur band upon which reception is desired.

c. KILOCYCLE - The tuning dial consists of two scales, the KILOCYCLE circular dial and the MEGACYCLE slide rule type dial. The KILOCYCLE dial is calibrated in 1 kc divisions on the 160, 80, 40, 20 and 15 meter bands and 2 kc divisions on the 11 and 10 meter bands. The lower scale on the dial is 2 kc per division while the upper center scales are 1 kc per division. The 3 scales are colored red, black and green to match the colors of the scale on the MEGACYCLE dial with which they are associated. The red scale is in reverse order to the other two scales and is used with the 160 meter slide rule scale. The green scale is used on the 10 and 11 meter bands while the black scale is used on the remaining bands.

d. MEGACYCLE - The MEGACYCLE dial is a slide rule dial calibrated in divisions of 100 kc each. Each scale is colored to match the associated scale on the KILOCYCLE dial. To read the tuning dial, combine the vernier dial (KILOCYCLE) reading with the slide rule dial reading. Thus, the 10 meter dial reading in figure 3-1 would be 28834 kc. The KILOCYCLE dial supplies the last two figures

of the frequency in kilocycles on all bands and the MEGACYCLE scale supplies the first two figures of the frequency in kilocycles in the 160, 80 and 40 meter bands and the first three figures in the 20, 15, 11 and 10 meter bands.

e. CRYSTAL FILTER-SELECTIVITY - The selectivity of the receiver is varied with the SELECTIVITY control. The band width is adjustable in five steps from 4 kc to 200 cycles at two times down (6 db down from the peak of the resonant frequency). Position 4 is sharp tuning while position 0 is broad tuning.

f. CRYSTAL FILTER-PHASING - The PHASING control is used primarily to assist in rejecting interfering heterodynes. The control, when positioned on the panel mark (straight up), is properly set for CRYSTAL-PHASING. In event a high frequency heterodyne is interfering with reception, the control should be moved back and forth in the vicinity of the panel mark until the heterodyne is attenuated. If the heterodyne is low frequency (low pitched whistle), the control should be moved further out from the panel mark on either side.

g. BFO PITCH - the BFO PITCH control is located to the right of the tuning control and is used to vary the pitch of the beat note when receiving CW signals. To set the BFO PITCH control, tune in a signal "on the nose" with the BFO off and the crystal filter SELECTIVITY at position 4. Then turn the BFO ON and set BFO PITCH as desired. Tuning should be centered on the carrier and the BFO offset to give desired beat note. If an approximate frequency check of the received signal is wanted, tune the signal to zero beat with the tuning dial and add one kc to the dial reading if the BFO control is set at +1 or subtract one kc if the control is set at -1.

h. CW-AM-FM - In the CW position, this control turns the BFO on, disables the AVC system, and turns the CW noise limiter on. In the AM and FM positions, this control disables the BFO and connects the AVC circuits for AM and FM operation. In addition, in the FM position, this control re-routes the input of the first audio stage to the FM adaptor plug so that narrow band FM signals can be reproduced through the audio section (providing of course, an nbfm adaptor is plugged into the adaptor socket).

j. RF GAIN - This control is connected in the grid circuits of the first RF stage and the fixed IF amplifier stages through the AVC circuit. It is used in all classes of operation. In FM and AM operation, the RF GAIN control is placed in the full clockwise position. In CW operation the AUDIO GAIN control is turned in full clockwise position and the RF GAIN control is used to control the sensitivity of the set. It will be noted that when the RF GAIN control is turned back from the clockwise position, the "S" meter will show a minimum reading up-scale from zero.

NOTE

To limit the sensitivity between stations (similar to squelch action), while listening to the desired signal, turn the RF GAIN control counter-clockwise until the "S" meter just starts to rise. The background noise will be reduced but good AVC will be in effect on signal strength increase.

k. **AUDIO GAIN.** - The **AUDIO GAIN** control is used to control the audio amplification of the receiver. This control is used primarily during AM and FM reception when the **RF GAIN** control is usually turned full clockwise to get full AVC action and to permit the "S" meter to read accurately.

m. **CW LIMITER.** - The **CW LIMITER** control sets the clipping level for the CW noise limiter. The CW noise limiter is turned on when the **CW-AM-FM** control is placed in the CW position. If limiting is not wanted in CW reception, the **CW LIMITER** control should be placed in the counterclockwise position (zero). Rotating this control clockwise increases limiting action. This control can be adjusted to limit at the audio level desired. Noise pulses can be limited to the same amplitude as the signal. This control is not used in phone reception since the clipping level for phone reception is pre-determined by the automatic noise limiter.

n. **LIMITER.** - The **LIMITER** control turns the automatic noise limiter on when placed in the straight up position. This circuit automatically adjusts the limiting threshold according to the strength of the received carrier. It is particularly effective on steep noise pulses, such as automobile ignition noise. Where noise conditions do not warrant its use, the noise limiter may be taken out of the circuit by placing the control in the **OUT** position. The **CAL** position on this control is provided to turn on the plate power of a crystal calibrator unit (not furnished).

o. **ANT. TRIM.** - This control is used to correct the detuning effect which an antenna may have on the input circuit. It should be set for maximum "S" meter reading on each band.

p. **ZERO SETTING.** - This small knob, located just beneath the kilocycle knob, is used to set the line on the **KILOCYCLE** scale to provide for very accurate frequency readings. This hairline can be set against the crystal calibrator (when installed) or against stations of known frequency or, on some bands, against **WWV** (at 30 MC on the 10 meter band, 15 megacycles on the 20 meter band, and at 2.5 megacycles on the 160 meter band). A linear scale located on the bottom edge of the **KILOCYCLE** dial opening can be used for locating the setting of the hairline on different bands so that the dial will not have to be recalibrated each time.

q. **"S" METER.** - The "S" meter is calibrated from one to nine in steps of approximately 6 db each, and for 20, 40 and 60 db above S-9. For "S" meter measurements the **RF GAIN** control should be advanced to the full clockwise position.

3.2.2. **OPERATING PRACTICES.** - In general, the receiver tunes the same way as any conventional receiver. The operator may have to get used to the extreme selectivity of the 75A receiver to fully appreciate it. For instance, actual single signal CW reception is an inherent feature of the receiver.

In addition, interfering signals may be completely phased out or greatly attenuated with the CRYSTAL PHASING control when using the crystal filter on CW. The CRYSTAL PHASING control is very effective on heterodynes in phone reception when the SELECTIVITY control is in position #1 to 4. The phasing notch is very sharp in these positions and must be very carefully sought. It is good practice to tune the signals in, peaking them with the crystal filter in use even though there are no interfering signals at the moment since the stability of the receiver is such that, should an interfering signal appear, the operator can immediately turn the filter on and have maximum selectivity without further retuning.

Position #1 on the SELECTIVITY Control is designed to allow maximum benefit of the rejection notch of the PHASING control without appreciably reducing the width of the "nose" of the selectivity curve. This feature is useful in phone reception. High-pitched heterodynes are noticeably attenuated by the selectivity of the 455 KC I.F. system. This leaves the PHASING control available for attenuating low-pitched heterodynes. The range of the PHASING control has been extended downward to approximately 250 cycles.

In AM operation, when monitoring a frequency where the desired signals are infrequent but of good strength, the background noise with no signal can be reduced by turning back the R.F. GAIN control. This is useful in monitoring a net frequency.

For reception of single-sideband-suppressed carrier signals, the receiver first should be adjusted for AM reception and the signal tuned for maximum indication on the S meter. Then the receiver should be adjusted for CW operation, with the RF gain reduced below the overload point. The BFO PITCH control should then be adjusted carefully to zero beat the suppressed carrier. To make the modulation intelligible, the BFO will need to be adjusted to within a few cycles of the carrier frequency.

To measure most accurately the frequency of a signal, adjust the receiver for AM, set the SELECTIVITY control at position 4, and tune in a signal of known frequency accuracy (such as WWV at 2.5, 15 or 30 MC) for maximum indication on the S meter. Set the ZERO SET control to put the hair line on exact calibration. Then with the SELECTIVITY control on position 4, tune in the signal to be measured for maximum indication on the S meter and read its frequency on the main tuning dial.

An alternate method is to adjust the receiver for CW operation and tune for exact zero beat with the known signal, then adjust the ZERO SET control to put the hair line on exact calibration. Next, without changing the setting of the BFO control, tune the unknown signal to zero beat and read the frequency from the main tuning dial. Increased accuracy can be realized by using a crystal calibrator unit and using the 100 KC point nearest the unknown signal for the reference. See paragraph 2.5 in this book.

SECTION IV
CIRCUIT DESCRIPTION

4.1. MECHANICAL.

4.2. GENERAL.

The 75A receiver is constructed in two major units, the receiver unit and the speaker unit. The receiver is constructed on an aluminum chassis. Both the receiver and speaker cabinets are constructed of heavy gauge steel. The receiver cabinet has a hinged cover utilizing inside hinges. Ventilation openings are punched in the sides and rear of the cabinet. The front panel is flush and trimmed for neat appearance. Both the receiver and the speaker cabinets are finished in a hard St. James gray wrinkle finish.

4.3. TUNING.

The vernier tuning dial is directly coupled to the lead screw of the variable frequency oscillator thus eliminating any possibility of back lash. The iron cores that tune the RF, first mixer, first IF and second mixer stages are all mounted on a movable platform. This platform is geared and belted to the BFO shaft by means of split gears and metal belts thus giving ganged tuning. The slide rule guide pointer is cable driven. The BFO coil is placed for most efficient operation and a long shaft is used to connect the tuning capacitor with the panel knob. All other stages are fixed-tuned with iron cores.

4.4. BAND SWITCHING.

Band switching of RF stages is accomplished by means of a multiple section switch gang. In addition to RF circuits, the band switch selects high frequency oscillator crystals.

4.5. ELECTRICAL THEORY.

4.5.1. CIRCUIT. - As shown in the block diagram, figure 1-1, the receiver has one stage of pre-selection. A high gain 6CB6 tube is used here because of its excellent electrical characteristics and desirable physical features. Following the RF stage is the first mixer of the double detection system. The signal grid of the tube, a 6BA7, is tuned to the received frequency, the injection grid receives voltage from the fixed high frequency oscillator circuits at a frequency within a band of either 2.5 to 1.5 megacycle or 5.455 to 3.455 megacycles removed from the received frequency. This oscillator voltage is supplied by a 12AT7 crystal oscillator tube. Since the high

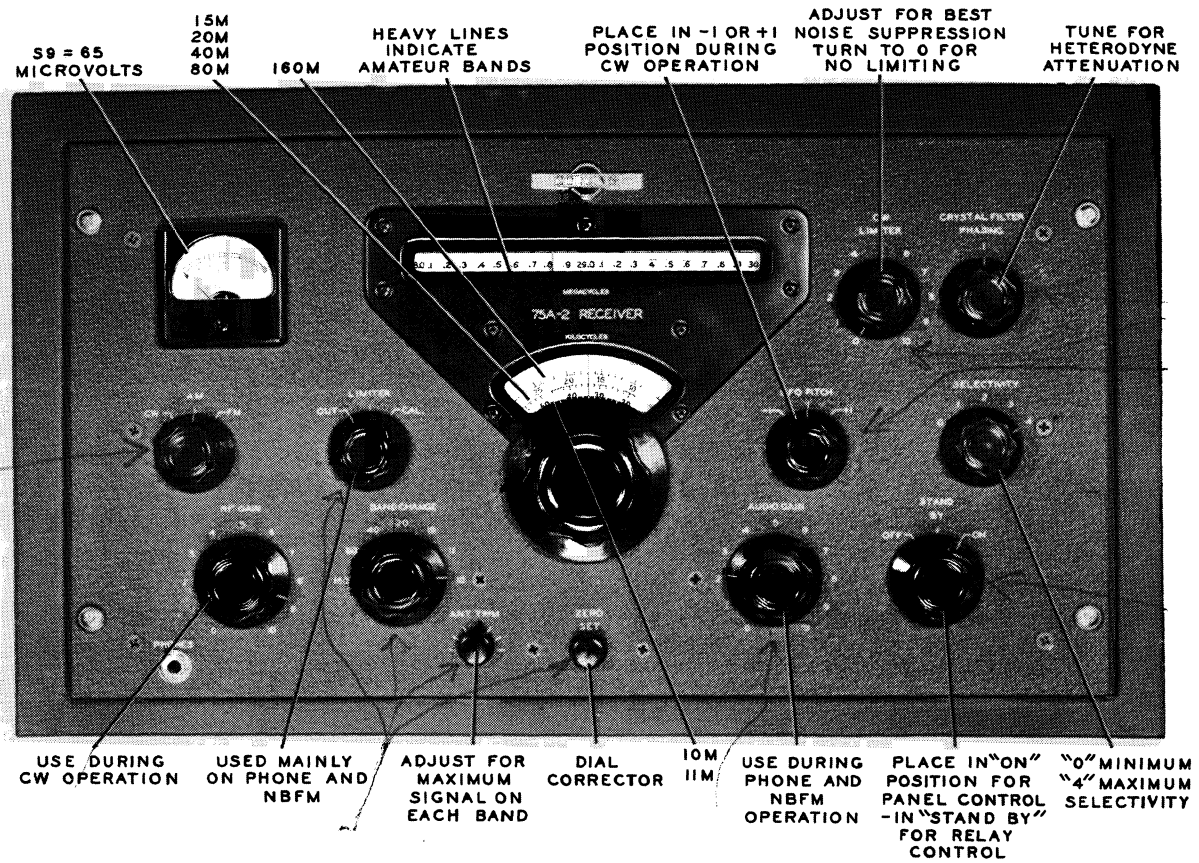

Figure 3-1. 75A-2 Operating Controls

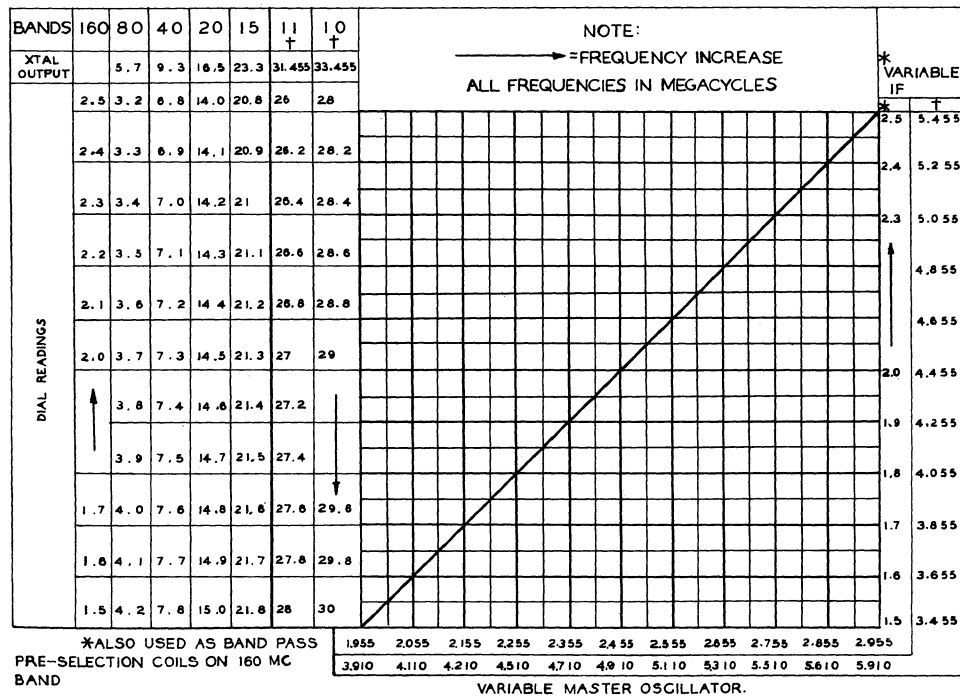

Figure 4-1 Frequency V.S. Dial Division Table

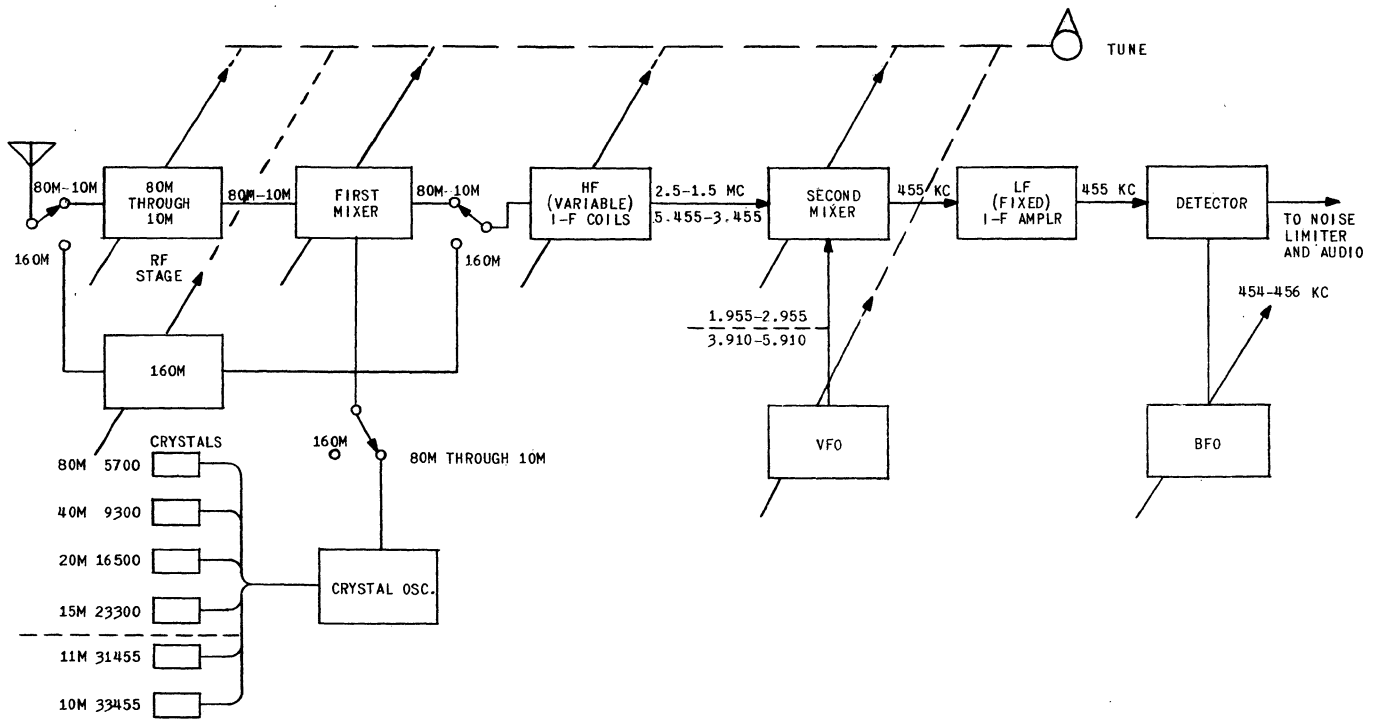

FIGURE 4-2 BLOCK DIAGRAM OF TUNING CIRCUITS

frequency oscillator frequency is fixed (by the quartz crystals) the output frequency of the first mixer tube varies. This necessitates a variable IF channel for the first intermediate frequency. Two tuned circuits are used in the variable frequency IF stage. The second mixer is a type 6BA7 tube, the injection grid of which is tuned to the frequency of the variable IF. To produce the second IF of 455 kc (fixed), the output of a precision variable frequency oscillator is fed into the signal grid of the second mixer tube. This oscillator employs a 6BA6 tube in a highly stabilized temperature compensated circuit followed by a 6BA6 isolation stage. The output of the second mixer tube is amplified by a 455 kc IF channel composed of three 6BA6 tubes. A 6AL5 tube as a detector and AVC rectifier follows the IF channel. The audio produced by the detector is amplified by 1/2 of a 12AX7 voltage amplifier and a 6AQ5 power amplifier. AVC bias is produced by 1/2 of 12AX7 tube in an AVC amplifier circuit. A type 6BA6 tube is used in a BFO circuit coupled to the detector input for CW reception. Single conversion is employed for the 160 meter band wherein the signal is amplified by V-1 and fed directly to the grid of the second mixer through the variable IF filter.

4.5.2. TUNING. - Tuning of the RF stage, the first mixer, the variable IF stage, the second mixer and the VFO is accomplished by changing the inductance of the tuned circuits by means of powered iron cores varied within the magnetic field of the coils involved. The tuning cores of all of the above stages are ganged together and are varied as one unit. The inductance of each coil is trimmed with a similar iron core whereas the capacitance trimming of each coil is done with a variable ceramic capacitor.

An unusual method of band change is employed in the 75A receiver for all bands other than the 160 meter band. In the RF and first mixer stages, the inductance of only one set of coils, the 80 meter set, is directly varied by the tuning cores. To change bands, the 80 meter coils are paralleled with tuned circuits having characteristics which will combine with the 80 meter coils to produce tuned circuits suitable for the new frequency range. Five sets of tuned circuits are used, one set for each band. In each case, however, the 80 meter coil is the only coil in which the inductance is directly varied by the tuning apparatus. Refer to the complete schematic, figure 5-5. The 160 meter band has its own separate antenna coil. The first mixer and crystal oscillator are not used in 160 meter operation. The high frequency range of the variable IF channel is produced by paralleling the tuned i-f coils with additional fixed tuned circuits.

The tuning ranges of the coils in both the RF portions and the variable IF portions are 1000 kc in the 160, 80, 40, 20 and 15 meter bands and 2000 kc in the 11 and 10 meter bands. The frequency coverages of the RF stages are:

160 meters = 2.5 to 1.5 mc	15 meters = 20.8 to 21.8 mc
80 meters = 3.2 to 4.2 mc	11 meters = 26.0 to 28.0 mc
40 meters = 6.8 to 7.8 mc	10 meters = 28.0 to 30.0 mc
20 meters = 14.0 to 15.0 mc	

The frequency coverage of the variable i-f stage is: 160, 80, 40, 20, 15 meter bands = 2.5 to 1.5 mc; 11 and 10 meter bands = 5.455 to 3.455 mc. In order to produce heterodynes suitable for amplification by the variable frequency i-f stage i.e., 2.5 to 1.5 megacycle or 5.455 to 3.455 megacycle, six high frequency oscillator outputs are necessary. These are obtained by the use of a crystal oscillator and six crystals (one for each band except 160 meters). Refer to figure 4-1 for a complete frequency vs. dial division table.

In each case, the high frequency oscillator output is higher in frequency than the received signal by 2.5 to 1.5 megacycle or 5.455 to 3.455 megacycle depending upon which band is being used.

Refer to figure 4-2. In order to get a 455 kc heterodyne for the second, or fixed, IF amplifier stages, it is necessary to introduce another signal to beat against the variable IF. Since the output of the variable IF changes from 2.5 to 1.5 megacycle or 5.455 to 3.455 megacycle, the output frequency of this new signal must also be variable and in the ranges 2.955 to 1.955 megacycle and 5.910 to 3.910 megacycles. These requirements are met by the use of a Collins 70E-12 precision oscillator which has a fundamental output frequency range of 2.955 to 1.955 megacycles. The second harmonic of the oscillator is 5.910 to 3.910 megacycles; the second harmonic output is used when the variable IF is 5.455 to 3.455 megacycles (when tuning in the 11 and 10 meter bands). The output of the variable i-f and the VFO are mixed in V-4 and the resultant 455 kc output is fed to the first 455 kc amplifier V-5.

The 455 kc intermediate frequency is amplified by a three stage amplifier, the output of which is rectified and sent through the noise limiter and audio amplifiers.

The beat frequency oscillator employs a 6BA6 in a highly stabilized circuit. The dial used in varying the VFO frequency is calibrated +1 and -1 kc; a feature useful in CW work for reading frequency. With the receiver tuned to zero beat, if the dial is set at +1 kc, add 1 kc to the vernier dial reading at zero beat for the exact frequency of the received station or if the dial is set at -1 kc, subtract 1 kc. The BFO PITCH control allows approximately ± 2000 cps change from zero beat.

Summarizing the above description of the tuning scheme of the 75A receiver; the received signal beats against the output of a crystal oscillator and produces an intermediate frequency which varies across the band. This variable intermediate frequency is mixed with a variable oscillator output to produce a fixed 455 kc i-f signal. The 455 kc signal is rectified and the resulting audio is fed through an automatic noise limiter to the audio stages.

Linear tuning is accomplished by the use of a cam wound coil, in the VFO, which has the coil turns spaced non-linearly in such a manner that linear movement of the tuning plug within the coil produces a linear frequency output of the oscillator. In addition, a mechanical frequency correcting mechanism is attached to the oscillator tuning slug. All coils which are tuned by movement of the tuning dial are wound similar to the oscillator coil.

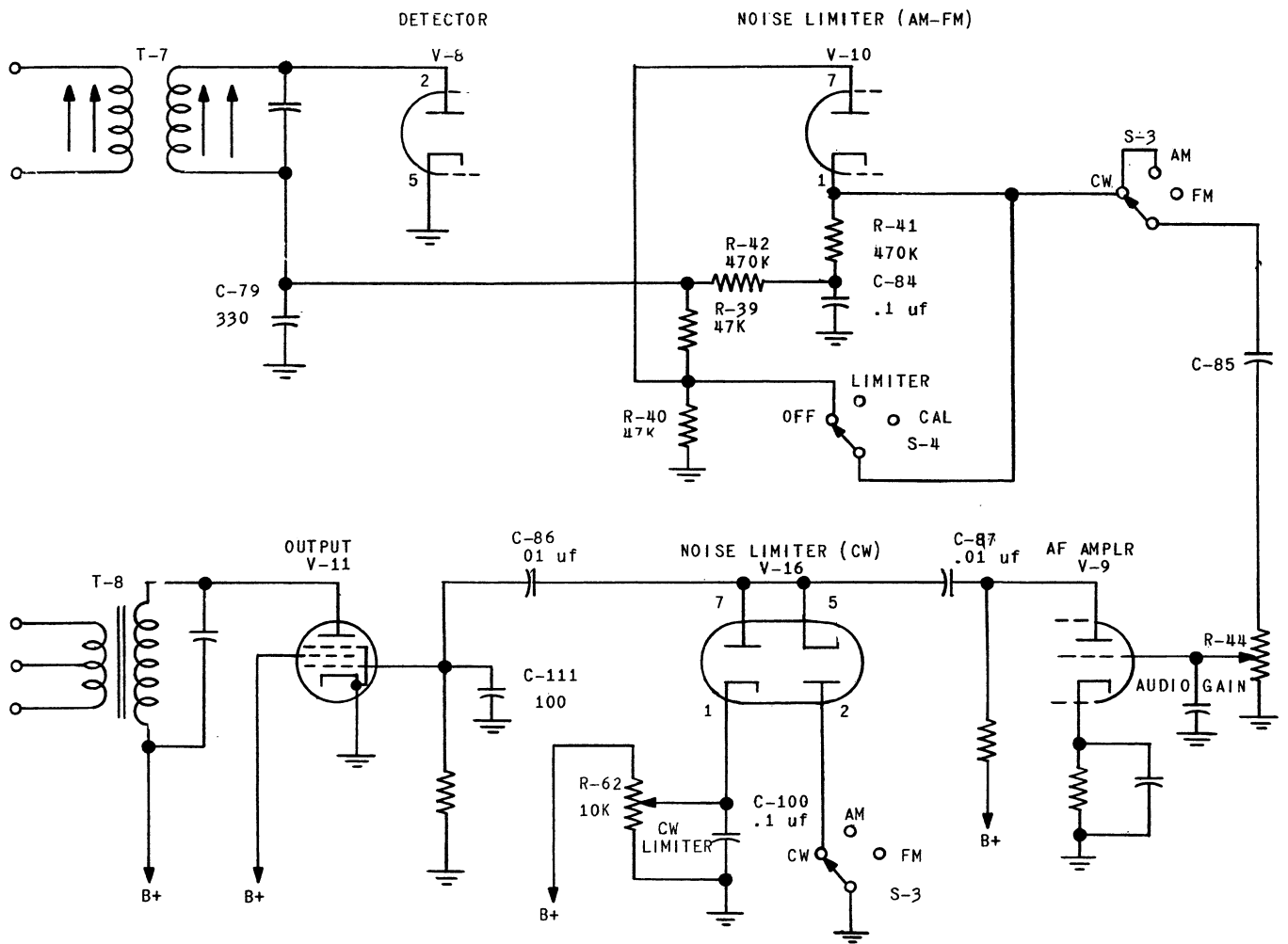

FIGURE 4-3 NOISE LIMITER CIRCUITS

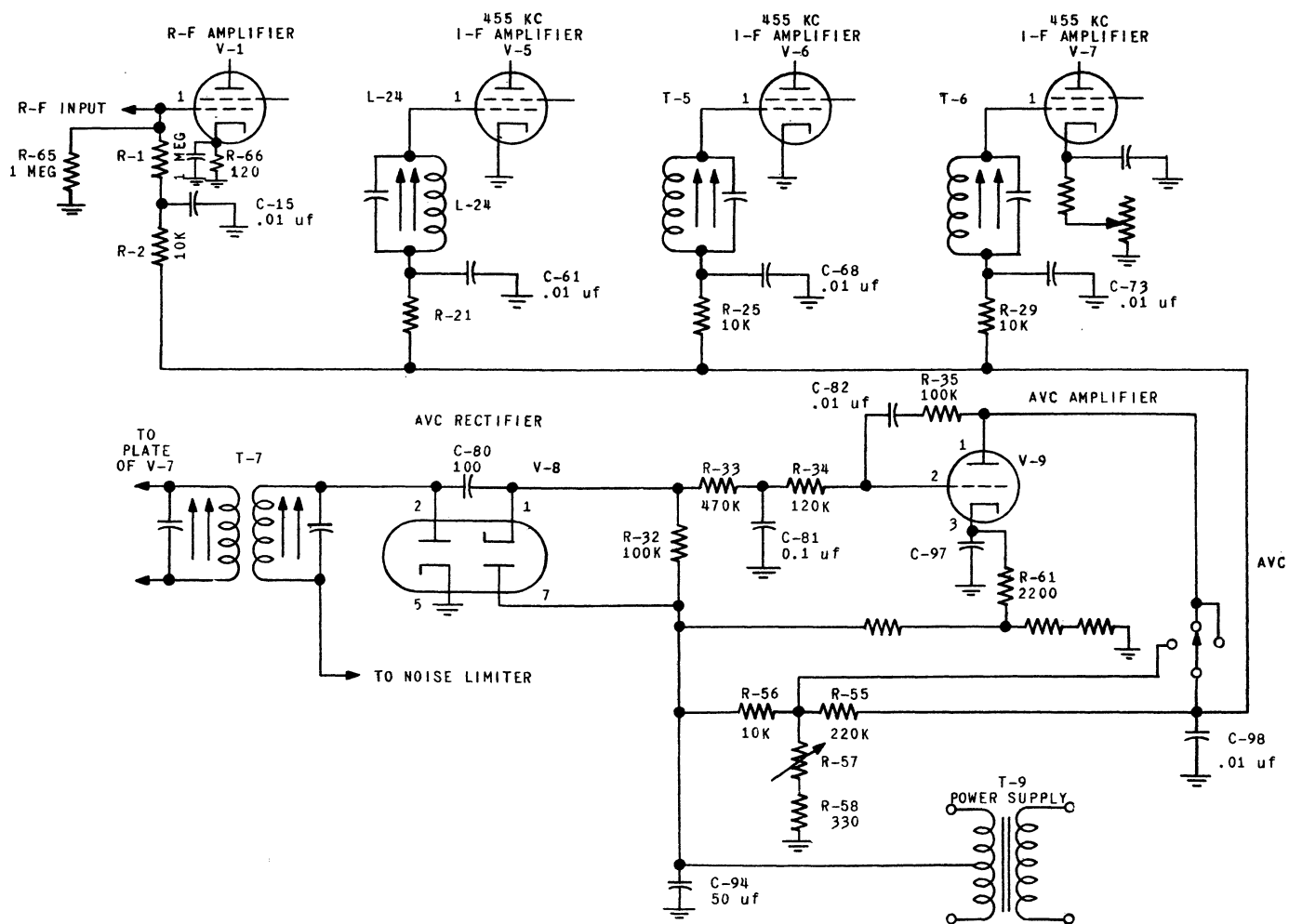

FIGURE 4-4 AVC CIRCUIT

4.5.3. CRYSTAL FILTER. - Refer to figure 5-5. The crystal filter in the 75A receiver functions as follows: The 455 kc IF channel input transformer T-3 has a tuned primary which is tuned to the intermediate frequency. The secondary on the transformer is a low impedance coil, the center tap of which is grounded. One stator of phasing capacitor C-58, is attached to one end of this secondary winding while one side of the filter crystal is attached to the other end. A bridge circuit is formed by attaching the rotor of the phasing control to the opposite side of the crystal. This point of attachment must return to ground (or center tap of the secondary of T-3) to complete the bridge of the circuit. This is done through the SELECTIVITY control resistors R-18, R-19, and R-20 or through IF coil L-24. The bridge circuit is necessary to balance out the capacity of the filter crystal holder plates to prevent the signal from bypassing the crystal. If the point of attachment of the rotor of C-58 and the output plate of the crystal was returned directly to ground, the Q of the crystal would be too high, therefore, resistors R-18, R-19, and R-20 are placed in series with the crystal circuit to vary the Q. When the SELECTIVITY switch S-2 is in the zero position, the crystal is short circuited and the selectivity is determined by the receiver circuits only. When the SELECTIVITY control is in position 1, the crystal Q is at its lowest point because of the return circuit through L-24 (a parallel tuned circuit having high impedance). When the SELECTIVITY control is in position 2, the Q of the crystal circuit is improved because of the lower value of series resistance and so on through positions 3 and 4 until at position 4 the series resistance is at the lowest useful value and the crystal Q is highest with a resultant high degree of selectivity.

Because the phasing capacity is across L-24, detuning of L-24 would normally occur when changing the setting of the phasing condenser. To neutralize this effect, an additional set of stator plates has been placed on the phasing capacitor to compensate for this detuning.

4.5.4. NOISE LIMITER. - A series type noise limiter is used in the 75A receiver for phone reception. This limiter employs 1/2 (pins 1 and 7) of the type 6AL5 dual diode tube V-10. Refer to figure 4-3. Due to AC loading of the second detector, heavy noise impulses are automatically clipped from the positive audio peaks in the detector. The noise appearing on the negative side of the audio cycle is clipped by the noise limiter. In operation, a negative voltage produced by rectification of the carrier, is developed across capacitor C-84. This voltage can not change rapidly due to the size of C-84 and R-42 through which C-84 is charged. This negative potential is placed upon the cathode of the noise limiter tube through R-41. The cathode is then negative in respect to the plate of the noise limiter tube and plate current flows. This plate current is modulated by the receiver audio. The modulated plate current produces audio on the noise limiter cathode (to which the grid of the audio amplifier section of V-9 is connected). The noise limiter diode will conduct as long as the cathode is negative in respect to the plate, however, when a heavy noise impulse is received, the plate is being driven

negative faster than the cathode can follow (due to the time constant of R-42 and C-84). If the plate is driven more negative than the cathode, the tube will cease to conduct and no audio will reach the grid of the following audio tube. The audio cannot reach the cathode of the limiter tube directly from the bottom of the detector transformer because of the filtering action of R-42 and C-84. The percentage of modulation, at which the limiter clips, can be adjusted by changing the values of R-39 and R-40. Increasing R-39 and decreasing R-40 while keeping the sum of their resistances at approximately 100,000 ohms will raise the percentage of modulation at which limiting starts. In this receiver, limiting starts at approximately 35% modulation with sine wave input. Distortion will be evident on heavily amplitude modulated signals, particularly if clipping is used at the transmitter. Switch S-4 bypasses the audio signal around the noise limiter when receiving conditions do not require its use.

4.5.5. CW NOISE LIMITER. - A separate noise limiter is used during CW reception. This limiter, a shunt type is bridged across the audio line to the 6AQ5 grid. This limiter short circuits the audio line on noise impulses above the level chosen by the operator. The value of limiting is adjustable by R-62, the CW LIMITER control. Refer to figure 4-3. A dual diode tube is used in this limiter. The adjusting bias applied to pin #1 is obtained from the main power supply. Capacitors C-86 and C-87 accumulate a charge so that clipping will occur equally on both the positive and negative portions of the audio cycle. This limiter is turned on automatically when placing switch S-3 in the CW position. If limiting is not wanted, the CW LIMITER control should be rotated to the counterclockwise position.

4.5.6. AUTOMATIC VOLUME CONTROL. - The problem of blocking due to strong signals or heavy static is reduced by the use of an amplified AVC system and a low impedance AVC line. Refer to figure 4-4. The second triode section of V-8 is used as an AVC rectifier to produce the control voltage for the AVC section of amplifier tube V-9. The AVC voltage applied to the grids of the controlled tubes is produced by the voltage drop across resistor R-55 when plate current flows through the AVC amplifier tube V-9. Plate voltage for V-9 is obtained from the voltage drop across resistors R-36, R-37 and R-38 which are in series with the center tap of the power transformer to ground. V-9 will not draw plate current, however, with no signal input to the receiver because of approximately 11 volts of bias placed upon its grid by the voltage drop through R-36. This bias voltage for V-9 is taken from the end of R-32 through which the rectified carrier flows in opposition to the bias voltage. Thus, when the rectified carrier becomes strong enough to overcome the bias voltage on V-9, V-9 will draw plate current and produce a voltage drop across R-55 thereby producing AVC voltage in proportion to the strength of the received signal. The bias on the grid of V-9 is high enough to produce adequate delay in the generation of AVC voltage to allow the receiver to function with full sensitivity on weak signals. Resistor R-33 and capacitor C-81 form the time constant in the AVC circuit. R-34 and C-82

and R-35 are used in a degenerative circuit to prevent the AVC amplifier tube from responding to low audio frequency. The AVC is turned off by opening the plate circuit of the AVC amplifier tube V-9. Tubes controlled by the AVC bias included V-1, the RF amplifier, V-5, V-6 and V-7, the 455 kc IF amplifier tubes.

4.5.7. AUDIO AMPLIFIER. - Two stages of audio amplification are employed in the 75A receiver. The first stage utilizes the second triode section of V-9 in a resistance coupled amplifier arrangement. A type 6AQ5 miniature pentode power amplifier tube is used in the audio output stage. This stage is biased with fixed bias obtained from the voltage drop produced across R-38 in the center tap lead of the high voltage transformer secondary. The 500 ohm secondary of the audio output transformer is tapped at 4 ohms to excite the voice coil winding of a speaker directly. Both the 500 ohm and the 4 ohm outputs are terminated on the rear of the chassis on terminal strip E-3. Headphone connections are also made to the 4 ohm tap. When the headphones are plugged into the headphone jack J-1, the speaker is disconnected and a 10 ohm loading resistor is connected across the 4 ohm winding in parallel with the headphones to load the 6AQ5.

4.5.8. 148C-1 NARROW BAND FREQUENCY MODULATION ADAPTOR. - The Model 148C-1 NBFM adaptor employs a type 6AU6 tube as a limiter and a type 6AL5 tube as a frequency discriminator. The limiter tube provides constant input to the discriminator tube due to the high value of grid load resistance (R201). The discriminator circuit used in this adaptor relies on the phase difference between primary and secondary in coupled circuits. A 90° phase difference exists between the primary and secondary potentials of a double tuned, loosely coupled transformer when the resonant frequency is applied, and this phase angle varies as the applied frequency varies. The potentials at either end of the secondary winding with respect to a center tap on that winding are 180° out of phase. When the center tap of the secondary is connected to one end of the primary, the potentials between the other end of the primary and each end of the secondary will reach maxima, one above and the other below the center frequency. At the center frequency, the resultant difference of potential between the two is zero. These potential differences vary at audio frequency rate when a frequency modulated signal is applied to the discriminator input. The audio frequency voltage is taken from the diode load resistors and sent through a de-emphasis network, R208 and C208, to pin number 2 of the power plug P203. The unit is ready to operate at all times by merely throwing the CW-AM-FM control on the 75A-2 Receiver to the FM position which disconnects the AM detector and substitutes the FM adaptor. The regular receiver audio circuits are used for FM reproduction. Operating voltages are provided by the receiver.

4.5.9. 8R-1 CALIBRATOR UNIT. - The 8R-1 Calibrator Unit uses a type 6BA6 tube in a Pierce circuit. A 100 kc crystal is used to give check harmonics at every 100 kc spot on the receiver dial. Capacitor C-301 is provided for zero beating the calibrator output with a known frequency standard such as a broadcast station in the tuning range of the 160 meter band or WWV at 2.5, 15 and 30 mc. The calibrator receives its operating voltages from the 75A-2 Receiver power supply and is turned on when the LIMITER control on the 75A-2 Receiver is placed in the CAL position. The output of the calibrator unit is coupled to the grid of the r-f amplifier tube V-1 through the capacity between pins 3 and 4 of crystal calibrator socket E-S.

SECTION V
MAINTENANCE

5.1. TROUBLE SHOOTING.

In general, trouble encountered in radio apparatus may be isolated by means of various tests and measurements, and the section of the equipment determined in which the trouble is located. If this is done, the components in the associated circuit may be checked and the trouble located. Refer to the table of resistance and voltage measurements.

NOTE

NO ONE BUT AN AUTHORIZED AND COMPETENT SERVICE MAN EQUIPPED WITH PROPER TEST FACILITIES SHOULD BE PERMITTED TO SERVICE THIS EQUIPMENT.

5.2. FUSES.

This equipment is supplied with a fuse of the correct rating. Fuse failures should be replaced with spares only after the circuit in question has been carefully examined to make certain that no permanent fault exists. Use only two ampere fuses.

5.3. ALIGNMENT (FOR NARROW BAND RECEIVER; FOR STANDARD RECEIVER FOLLOW PARAGRAPH 5-12).

5.3.1. EQUIPMENT AND TOOLS USED FOR ALIGNMENT.

- a. 455 kc to 30 mc signal generator.
- b. Fiber or bakelite adjusting tool, approximately 1/8" diameter with screwdriver type bit.
- c. Vacuum tube voltmeter such as the Voltomyst Jr.
- d. 100 kc frequency standard having harmonic output from 1.5 to 30.0 mc and accuracy better than .001%.

5.3.2. 455 kc I.F. ALIGNMENT.

- a. EQUIPMENT SET-UP
 1. Connect the lead of the signal generator to pin No. 1 of V7. Tune signal generator to 455 kc.
 2. Connect the vacuum tube voltmeter (VTVM) d-c lead to the diode lead, (Junction of R39 and R42).

3. Set the CRYSTAL SELECTIVITY control to the No. 0 position AUDIO GAIN control at minimum. RF GAIN control maximum. Place the CW-AM-FM switch in the AM position.

b. ALIGNMENT PROCEDURE (slight misalignment). See figure 5-1.

1. Increase signal generator level until an increase above the static level is noted on the VTVM.

2. Adjust both primary and secondary tuning cores of T4, T5, T6 and T7 for a maximum indication on the VTVM.

3. With the signal generator lead on pin No. 7 of V4 and with CRYSTAL SELECTIVITY switch on position 4, carefully tune generator until maximum diode load voltage is obtained. Maintain the input below the AVC threshold point. (Approximately 8V).

4. With signal generator adjusted as in step 3 above, place the CRYSTAL SELECTIVITY switch to zero. Adjust all four i-f transformers for maximum diode load voltage.

5. Place CRYSTAL SELECTIVITY control on No. 1 position. Move the signal generator dial to 3 KC lower frequency. Adjust signal generator output to give 5 volts of diode load voltage.

6. Adjust crystal grid coil L-24 for a maximum output indication.

7. The knob on the phasing control should be set so that minimum hiss is present when positioned at the center of the scale.

NOTE: In step 5., it may be easier to reconnect the signal generator to the receiver input and inject an amateur band signal, then detune the receiver dial 3 kc lower from peak resonance. Adjust signal generator output for 5 V diode load voltage.

c. ALIGNMENT PROCEDURE. (Large Misalignment)

1. If the misalignment is great, it may be impossible to force a signal through the i-f strip in step 1, paragraph b above. If this is the case, attach the signal generator output to the grid of V-7 and align T-7, then move the signal generator output to the grid of V-6 and align T-6. Repeat at the grid of V-5 and align T-4 and T-5. Then perform all the steps in paragraph b above for final alignment.

5.3.3. ALIGNMENT OF BFO

This should be performed after all other frequency controlling elements are aligned.

Connect the signal generator to the antenna terminals and tune both the receiver and generator to the 80M band. Place the crystal filter knob in #4 position. Leave the receiver in AVC position and tune in the signal from the generator to exact crystal filter frequency as indicated by a sharp rise in "S" meter reading. The BFO PITCH control should be set at center. Turn the MAN-AVC-CW Control to CW and adjust the BFO trimmer adjustment (In the top of the BFO coil) to zero beat. If the knobs have been removed, it is likely that the BFO PITCH knob will have been replaced incorrectly. The BFO PITCH knob should be centered when the associated tuning capacitor is at the half capacity setting. To check the position of the capacitor, proceed as follows: Connect the signal generator to pin 7 V4 and turn the MAN-AVC-CW control to CW. Having aligned the BFO as outlined above, rotate the BFO PITCH Control to each side of zero 180 degrees. The tone should change an equal amount on each side of zero. If such is not the case, the knob pointer is not at the center point of the capacitor. To correct this, rotate the control until the highest pitch obtainable is found. (This indicates that the capacitor plates are all in or all out.) Loosen the BFO PITCH Control set screw and turn the knob 90° (right or left) from the center (BFO) marking on the panel. (This sets the knob at half capacity on the capacitor.) Now return the knob marker to zero again and adjust the BFO Coil trimmer to zero beat note. It is possible now that the BFO PITCH knob is rotated 180 degrees on the shaft. To check this loosely couple the signal generator to the antenna connections on the receiver, set the signal generator at some 100 kc point (such as 3700 kc) and tune in the signal to zero beat with the BFO PITCH control set at zero and the receiver set up for CW reception. Rotate the BFO knob to +1. Retune the signal to zero beat using the tuning dial of the receiver. If the dial indicates 1 kc less than the previous reading, the BFO knob is on the shaft correctly. If the tuning dial indicates 1 kc more, the BFO knob should be loosened and rotated exactly 180 degrees on the condenser shaft.

5.3.4. ADJUSTMENT OF CRYSTAL OSCILLATOR.

- a. Connect lead of VTVM through 1 meg. isolating resistor to pin No. 7 of V2.
- b. Place band switch on 80 meters. Adjust L-12 for a maximum output indication.
- c. Successively change band switch to 40, 20, 15, 11 and 10 meters and successively adjust L-13, L-14, L-15, L-16 and L-17 for a maximum indication.
- d. The frequency of the crystal oscillator can be adjusted over a limited range by the controls named in steps b and c above. After the rest of the receiver is aligned this feature may be used to reduce the calibration error between bands. Couple the receiver to the output of an accurate frequency standard providing harmonically related output every 100 kc.

Start with the receiver tuned to zero beat with 2.000 mc. Do not turn tuning dial or BFO PITCH control during remainder of this adjustment. Turn BAND CHANGE control successively to the remaining bands and adjust receiver to zero beat by adjusting controls noted in steps b and c above.

Note that detuning of the crystal oscillator will reduce the crystal injection voltage at the first mixer. In most cases this effect is small and can be tolerated. In some cases the crystal oscillator may stop oscillating when its frequency is changed considerably. If this happens the ZERO SET control may be used instead to get exact calibration of the band in question.

5.3.5. VARIABLE I.F. ALIGNMENT.

a. EQUIPMENT SET-UP

1. Connect signal generator to the first mixer V2, pin No. 1.
2. Connect voltohmmeter at diode load resistor, (Junction of R39 and R42).
3. Adjust the front panel controls as follows: OFF-STANDBY-ON switch in ON position, CW-AM-FM switch on AM, CRYSTAL FILTER - SELECTIVITY switch on 0, CRYSTAL FILTER-PHASING on line, AUDIO GAIN maximum, BAND CHANGE switch on 80 meters.

5.3.6. 2.5. - 1.5 MC I.F. ALIGNMENT.

- a. Move signal generator lead to pin No. 1 of the first mixer V2.
- b. Set dial at 4.1 mc. Adjust signal generator to 1.6 mc. Adjust tuning cores, L-18 and L-22 for a maximum output indication.
- c. Set dial at 3.3 mc. Adjust signal generator to 2.4 mc. Adjust trimmers C-46 and C-53 for maximum output.
- d. Repeat steps b and c until no further increase can be obtained.

5.3.7. 5.455 - 3.455 MC I.F. ALIGNMENT.

- a. Place BAND CHANGE switch on 10 meters.
- b. Signal generator output lead should remain connected at pin No. 1 of V2.
- c. Set dial at 30.0 mc. Adjust signal generator tuning to 3.455 mc. Adjust tuning cores L-19 and L-23 for a maximum output indication.
- d. Set dial at 28.0 mc. Adjust signal generator tuning to 5.455 mc. Adjust trimmer C-43 and C-51 for a maximum output indication.

- e. Repeat steps c and d until no further increase can be obtained.

5.3.8. TWEET TRAP ADJUSTMENT.

a. A Third order tweet appears at 3533 kc in the 80 meter CW band and is caused by the signal of the 5.7 mc crystal beating with the second harmonic of the VFO at the mixer V4. A coil, L-21, is series resonant with C-52 and C-53 at 5.7 mc and effectively reduces this tweet.

b. To adjust L-21, turn on the BFO, tune in the tweet and adjust the core until the tweet is at a minimum.

5.3.9. R.F. ALIGNMENT.

a. EQUIPMENT SET-UP

1. Connect signal generator lead to antenna connection of receiver.
2. Connect Voltohmyst at diode resistor, (Junction of R39 and R42).

b. PROCEDURE.

1. Rotate band switch to 160 meters. Tune the receiver and signal generator to 1.6 mc. Adjust T1 tuning core for a maximum output indication.
2. Tune the receiver and signal generator to 2.4 mc and peak capacitor C5 for maximum output.
3. Continue back and forth until no improvement is noted.
4. Repeat for other bands using the following table as a guide.

	RECEIVER AND SIGNAL GEN. LOW END	RF INDUC- TOR	ANT INDUC- TOR	RECEIVER AND SIGNAL GEN. HIGH END	RF CAPACI- TOR	ANT CAPACI- TOR
160	1.6		T1	2.4		C1
80	3.3	L6	T2	4.1	C21	C6
40	6.9	L7	L1	7.7	C18	C2
20	14.1	L8	L2	14.9	C19	C3
15	20.9	L9	L3	21.7	C20	C4
11	26.2	L10	L4	27.8	C25	C10
10	28.2	L11	E5	29.8	C26	C11

5.3.10 VFO ADJUSTMENT. - The VFO is carefully adjusted and sealed at the factory and should never require further adjustment in normal circumstances. Should the oscillator drift beyond the point at which the vernier dial connector (Zero Set Control) can compensate, tune the receiver to an accurate 2000 kc frequency standard, set the vernier dial corrector to mid-scale, loosen two set screws on one half of the coupler on the oscillator shaft, then carefully turn the oscillator shaft until zero beat is obtained.

Make final adjustment with the CW-AM-FM Switch in the AM position and SELECTIVITY control at position 4. Adjust the oscillator shaft for maximum indication on the "S" meter and maintain this while tightening screws in coupler on oscillator shaft.

The tuning rate of the VFO may be checked by setting the tuning dial to exact zero beat with a frequency standard at each end of one tuning range, (14.000 and 15.000 mc, for instance). The tuning dial travel between these two points should be 10 turns plus or minus 3 dial divisions. If the error is greater than 3 dial divisions the oscillator should be removed and returned to the factory for adjustment. Never attempt to adjust the oscillator at home since breaking the seal would probably result in a much worse drift than was first experienced. After installing the repaired oscillator, it will be necessary to align the oscillator with the dial. To do this, carefully turn the oscillator shaft to the clockwise stop. WARNING; do not force the shaft, stop turning at the first sign of a drag. Set the vernier dial at 2.000 mc on the 160 meter band with BFO on. Turn the receiver on and couple a 2000 kc frequency standard to pin 7 of V4. Rotate the oscillator shaft approximately 5 turns CCW until a tweet is heard in the speaker. Adjust to zero beat.

Make final adjustment with the CW-AM-FM control on AM and the SELECTIVITY control at position 4. Adjust oscillator shaft for maximum indication on "S" meter. Tighten set screws in coupler.

5.4. DIAL CORDS.

5.4.1 GENERAL. - The front panel must be removed to replace either the dial pointer cord or the drum rotator cord. Figure 5-2 shows both cords in place and the direction in which the restringing should proceed.

5.4.2. FRONT PANEL REMOVAL.

- a. Remove the receiver from its cabinet.
- b. Remove the six panel screws.
- c. Remove the following knobs:
 - CRYSTAL FILTER PHASING
 - SELECTIVITY
 - BFO PITCH (See CAUTION below).
 - ANT TRIM
 - BAND CHANGE
 - TUNING

CAUTION

Set the BFO PITCH control knob on the index mark (straight up) and do not move the control after the knob has been removed. If the control has been accidentally moved, see paragraph 5.3.3. for instructions for adjusting the knob position.

5.4.3. POINTER CORD. - Obtain at least 33 inches of 432 1009 00 dial cord and tie loops in each end so that the cord is 29-3/8" long, over all. The spring part number is 503 1240 001, if a new one is necessary.

- a. Turn the tuning knob to the clockwise stop.
- b. Start at point X in the drawing with the cord hooked to one end of the spring.
- c. Go around pulley C to pulley B.
- d. Start around pulley B. clockwise and go through the deep slot in pulley B, around the tab and back through the shallow slot in pulley B. Go around pulley B two times clockwise.
- e. Go around pulley A with the cord and loop the end on the other end of the spring.
- f. Fasten the pointer to the cord, tune in a station of known frequency and adjust the pointer to correct setting.
- g. Replace the panel.

5.4.4. DRUM CORD. - Obtain a 15 inch length of 432 1009 00 cord and tie loops in each end so that they are 12 inches apart.

- a. Turn the BAND SWITCH to the 1.5 - 2.5 mc band (pulley D to the counter-clockwise stop).
- b. Turn pulley E approximately one turn and hold the tension of the tension spring.
- c. Loop cord in pulley D. Make approximately 3/4 turn around pulley D.
- d. Extend the cord around pulley E and hook to the tab. Release the tensions spring.
- e. Replace the panel.
- f. Loosen the set screw in the drum hub opposite the coil tension spring and align the dial calibration to the 1.5 - 2.5 mc band then tighten the set screw.

5.5. ALIGNMENT OF 148C-1 NBFM UNIT.

The NBFM unit is aligned to the exact receiver intermediate frequency. With the receiver to be in satisfactory alignment, tune in a good, steady, unmodulated carrier using the "S" meter for indication of "on the nose" tuning. Place the CW-AM-FM control in the FM position. Connect a high impedance DC voltmeter between pin 2 of E2 and ground. Align as follows:

- a. Detune the secondary of T-201 (top screw).
- b. Tune the primary of T-201 (bottom screw reached through a hole in the 75A chassis) for maximum DC voltage indication.
- c. Tune the secondary of T-201 (top screw) for zero d-c voltage indication. NOTE: There is a possibility of three minimum indications, the correct zero indication is the one at which, within a few turns of the screw, the voltmeter swings rapidly from a positive to a negative indication.

5.6. NARROW BAND CONVERSION.

5.7. GENERAL - This receiver is designed with bandwidth of 4 kc at 6 db down and 13 kc at 60 db down. It is possible to convert the 75A-2 Receiver to a maximum bandwidth of approximately 2.4 kc at 6 db down if extreme selectivity is desired. (See the curve preceding Section 6 of this book).

5.8 PROCEDURE. - To convert the set, remove the bottom plate and proceed as follows:

- a. Remove the 100,000 ohm resistor R-68 from terminals A and C on T-3.
- b. Remove the 5 uuf capacitor C-108 from terminals A and D on T-4.
- c. Remove the 5 uuf capacitor C-109 from terminals A and D on T-5.
- d. Remove the 10 uuf capacitor C-110 from terminals A and D on T-6.
- e. Realign the set as outlined in paragraph 5-3 of this book. The bandwidth will be 2.4 kc at 6 db down and 9.5 at 60 db down.

5.9. BROAD BAND CONVERSION.

5.10. GENERAL - To align the receiver after converting from narrow band to broad band, a slightly different procedure from that indicated in paragraph 5-3 is used. The bandwidth will be approximately 4 kc at 6 db down and 13 kc at 60 db down.

To convert to broad band, perform steps a. through d. in paragraph 5.8 above in reverse. That is, add these items rather than remove them. Then realign the i-f stages as follows:

5.11. TEST EQUIPMENT REQUIRED.

- a. Signal Generator
- b. Vacuum Tube Voltmeter (Voltohmyst)
- c. Swamping Tool - Comprised of a .01 mf capacitor in series with a 1000 ohm resistor and having an alligator clip on each end.

5.12. REALIGNMENT.

a. SET CONTROLS -

1. CW-FM-AM control to AM.
2. SELECTIVITY control on position 2.
3. RF GAIN to full on (Position 10).

b. PROCEDURE -

1. Connect the VTVM to the diode load.
2. Couple the signal generator to terminal 1 on V-4.
3. Adjust unmodulated signal input to give 5 volts dc on the diode load, measured at terminal C on T-7 or junction of R-39 and R-42. As the alignment progresses, reduce the signal input to give approximately this figure in order to stay below the AVC threshold. Keep the signal generator tuned to the exact frequency of the crystal filter as indicated by maximum diode load voltage.
4. Tune T-3 trimmer core for maximum diode voltage.
5. Place swamping tool between terminal D (Primary) of T-4 and ground and adjust bottom (secondary) trimmer screw for maximum diode voltage.
6. Place swamping tool on terminal A (secondary) of T-4 and adjust top (primary) trimmer screw for maximum diode voltage.
7. Repeat steps 5 and 6 with T-5, T-6, and T-7.
8. Refer to paragraph 5.3.2.6. (ALIGNMENT PROCEDURE) and perform steps 3, 5, 6, and 7 (omitting step 4) of this procedure.

D.C. SOCKET VOLTAGES 75A-2

- Conditions: 1. AM
 2. RF Gain Full On
 3. AF Gain Off
 4. Band ---80 Meters No Signal
 5. All voltages measured to ground with voltohyst.
 (VTVM)

Tube No.	Tube Type	1	2	3	4	5	6	7	8	9
V ₁	6CB6	-.2	0	0	6.3AC	135	95	0		
V ₂	6BA7	90	-3.6	.9	6.3	0	0	0	0	135
V ₃	12AT7	125	0	1.1	0	0	125	-2.4	1.1	6.3
V ₄	6BA7	+95	-4.4	8	6.3AC	0	0	0	0	155
V ₅	6BA6	-1.55	0	0	6.3AC	168	72	0.5		
V ₆	6BA6	-1.55	0	0	6.3AC	152	80	0		
V ₇	6BA6	-1.55	1.25	0	6.3AC	158	84	1.25		
V ₈	6AL5	-45	-0.9	0	6.3AC	0	-48	-48		
V ₉	12AX7	-1.5	-43	-40	0	0	123	0	1.3	6.3
*V ₁₀	6AL5	-1.3	0	0	6.3AC	1.2	-2	-1.4		
V ₁₁	6AQ5	-12	0	0	6.3AC	180	165	-12		
**V ₁₂	6BA6	-7.7	0	0	6.3AC	23	70	0		
V ₁₃	5Y3GT	0	208	145	-55	0	-55	0	208	
V ₁₄	6BA6	-2.2	0	0	0	50	50	0		
V ₁₅	6BA6	-2.0	0	0	0	100	70	0		
V ₁₆	6AL5	23	0	0	6.3AC	0.3	0	0.3		
V ₁₇	0A2	0	0	0	0	150	0	0		

* Limiter On
 ** C.W. ON

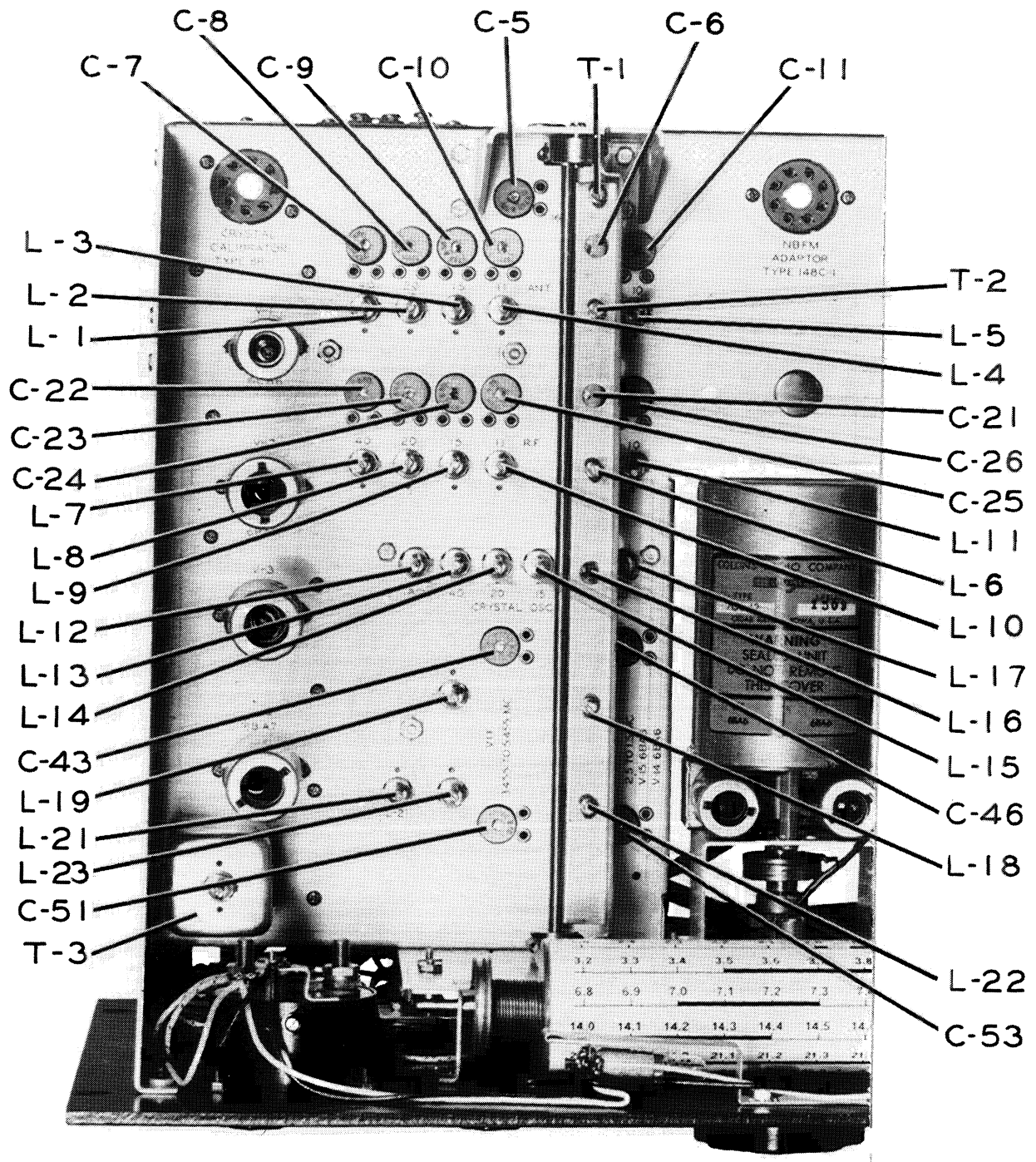

Figure 5-1. 75A-2 Alignment Adjustments

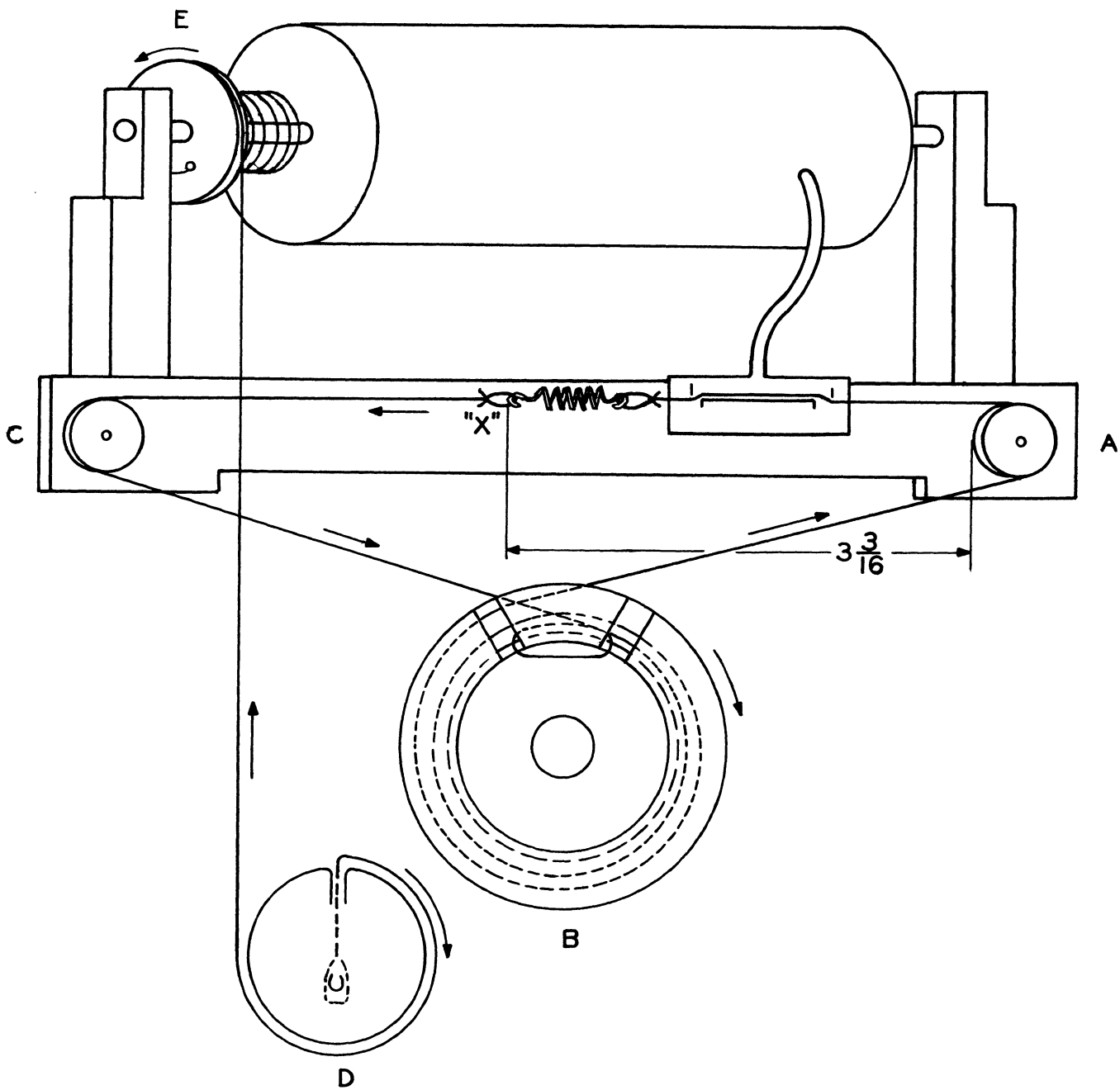

Figure 5-2. Dial Cord Replacement

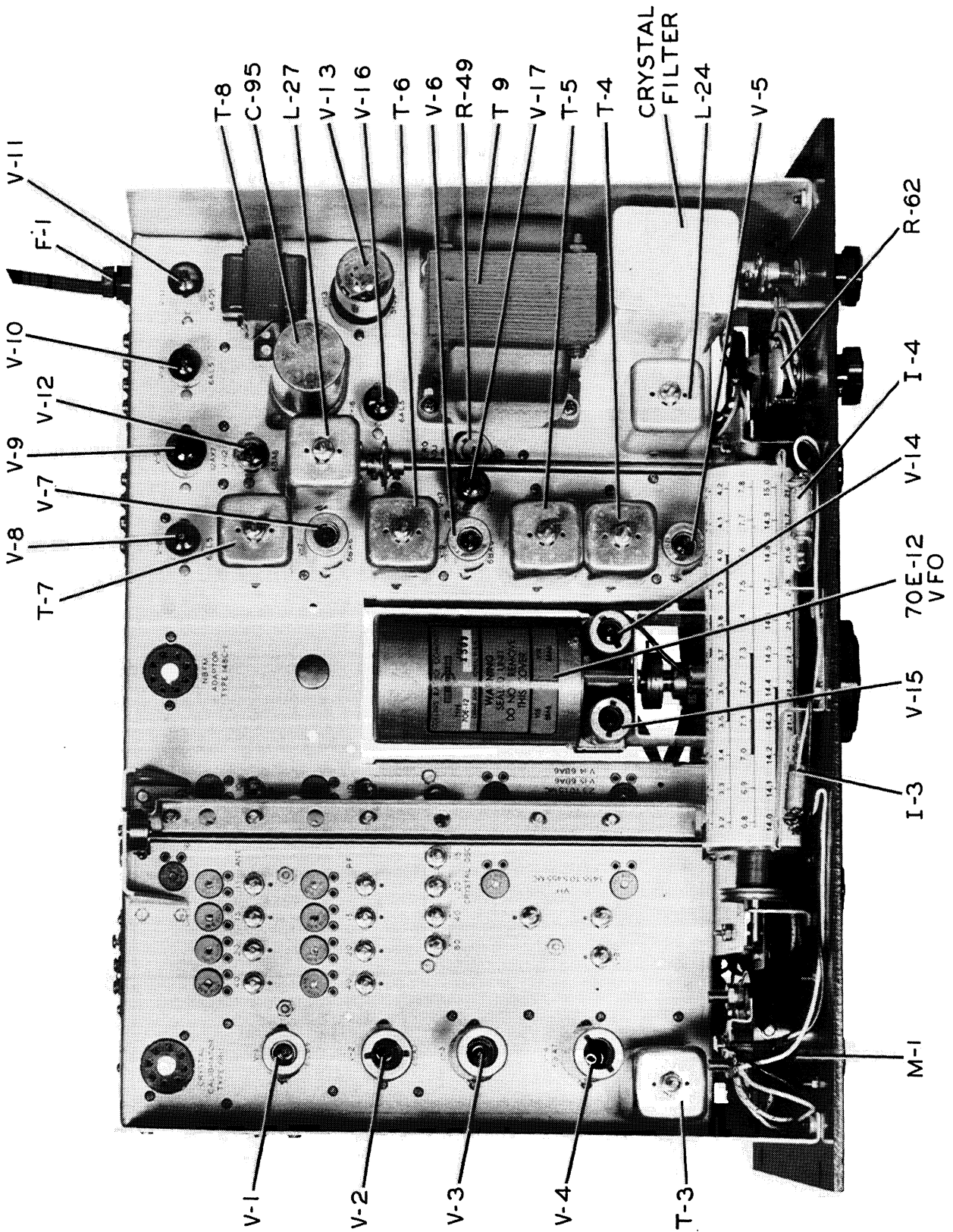

Figure 5-3. 75A-2 Top View

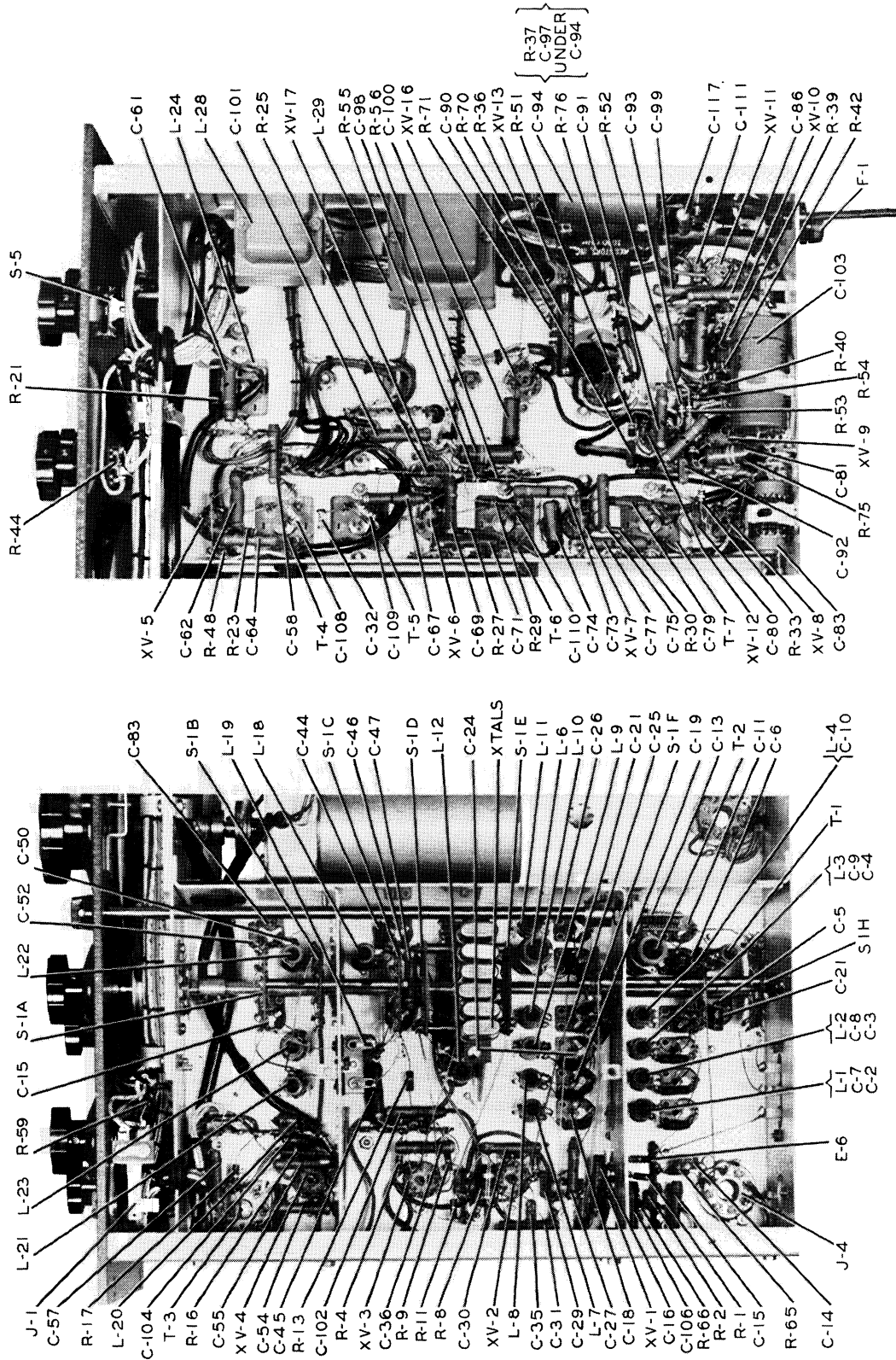

Figure 5-4. 75A-2 Bottom View

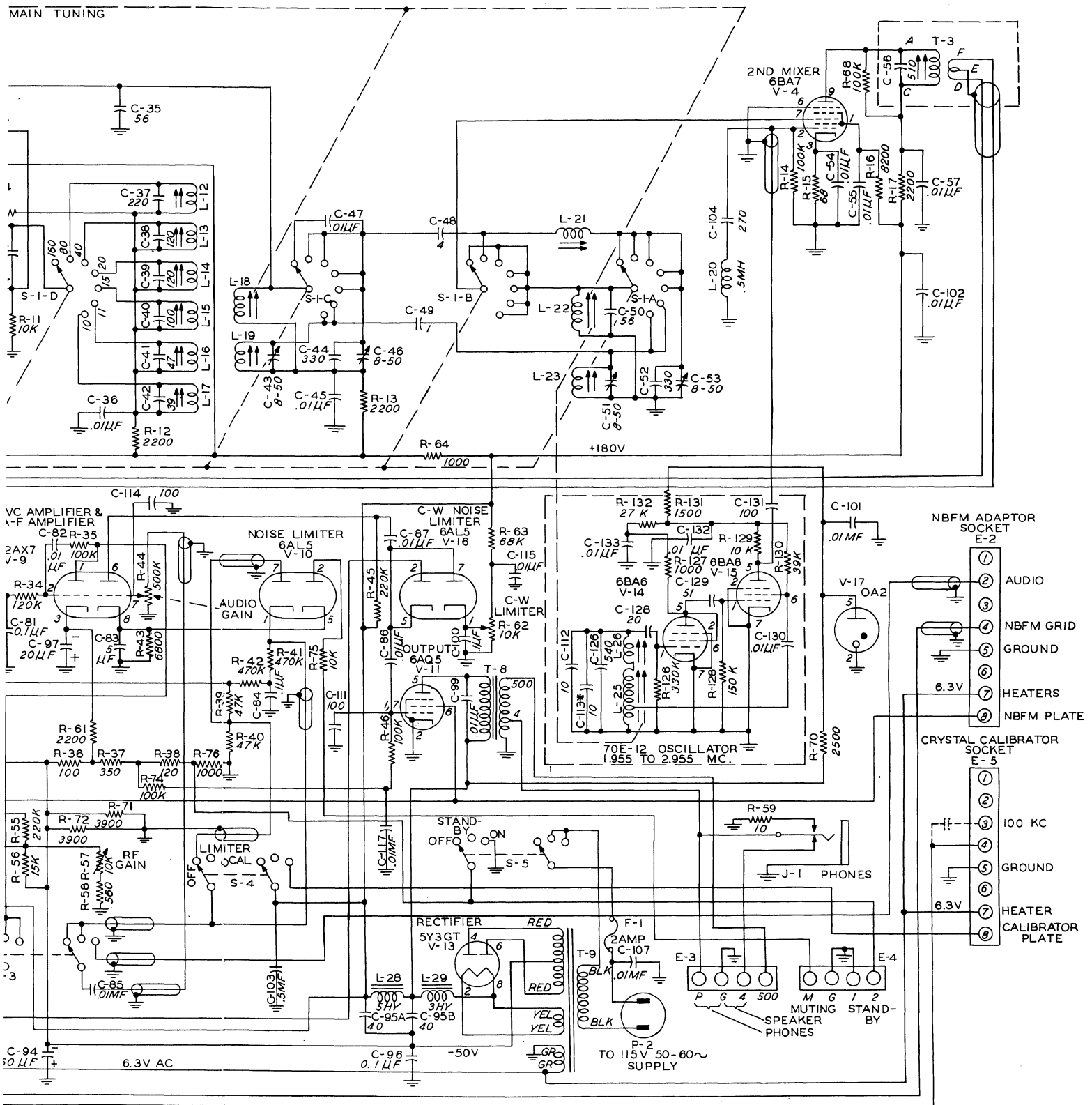
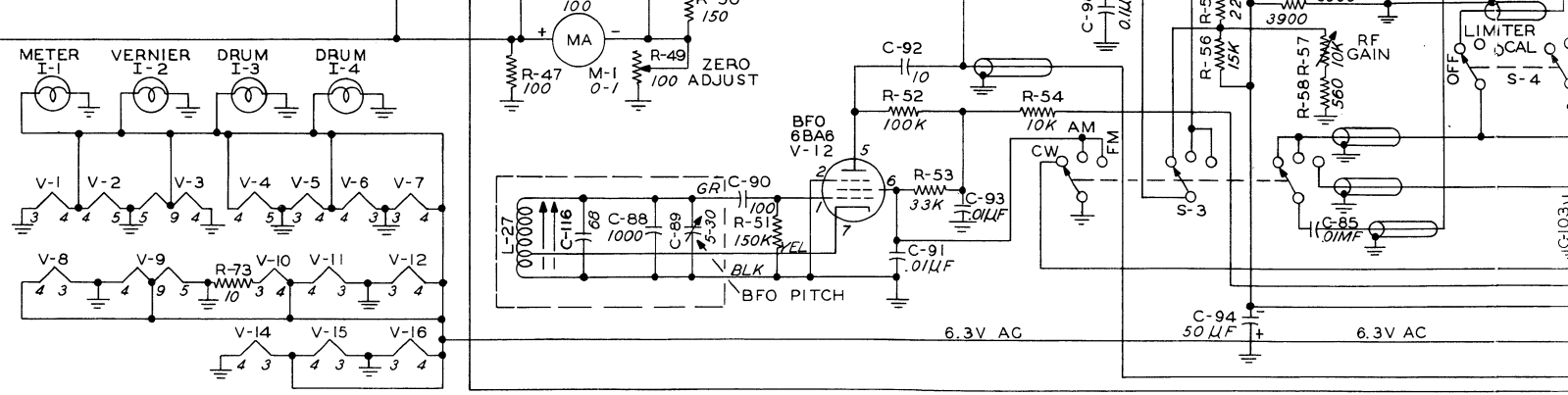
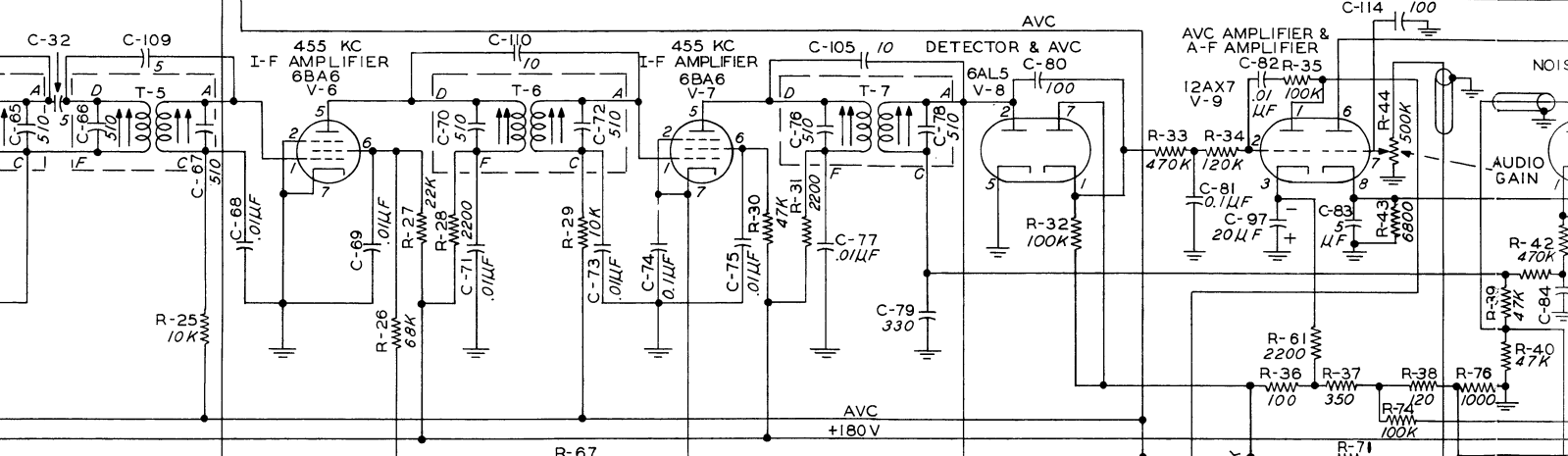
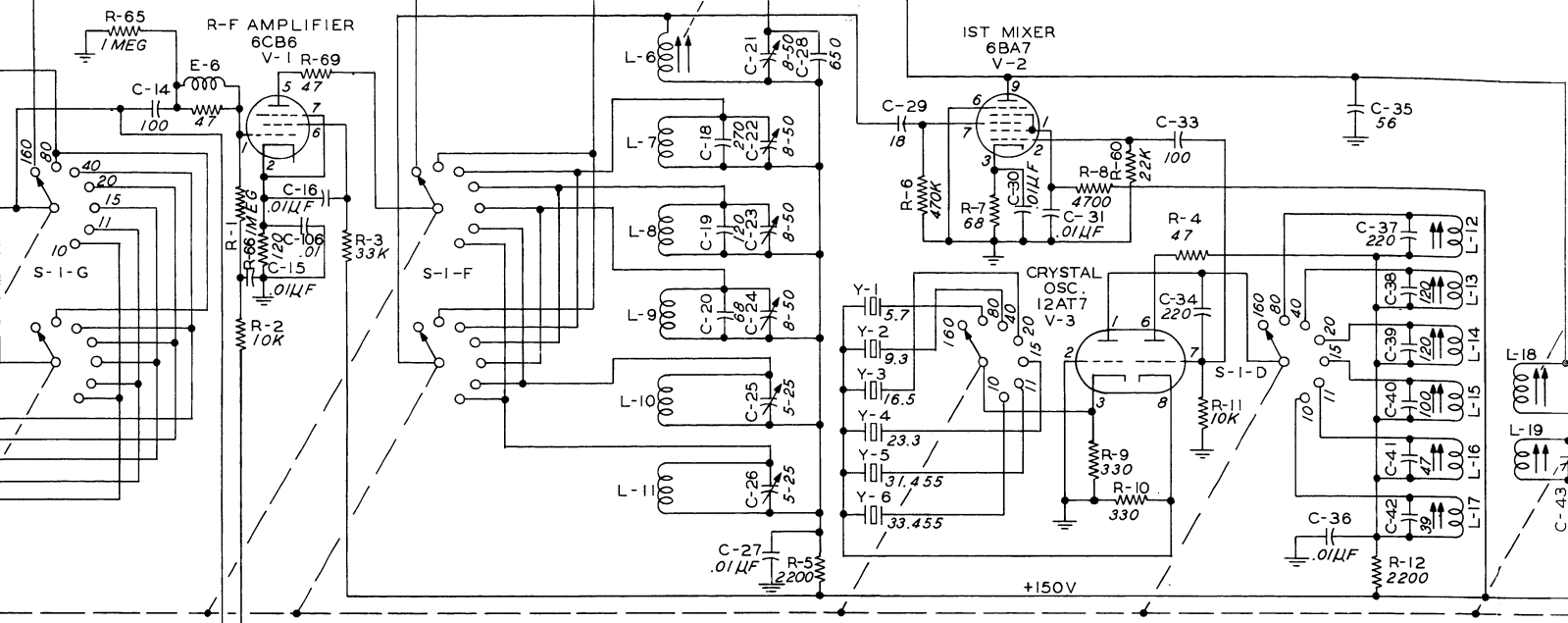
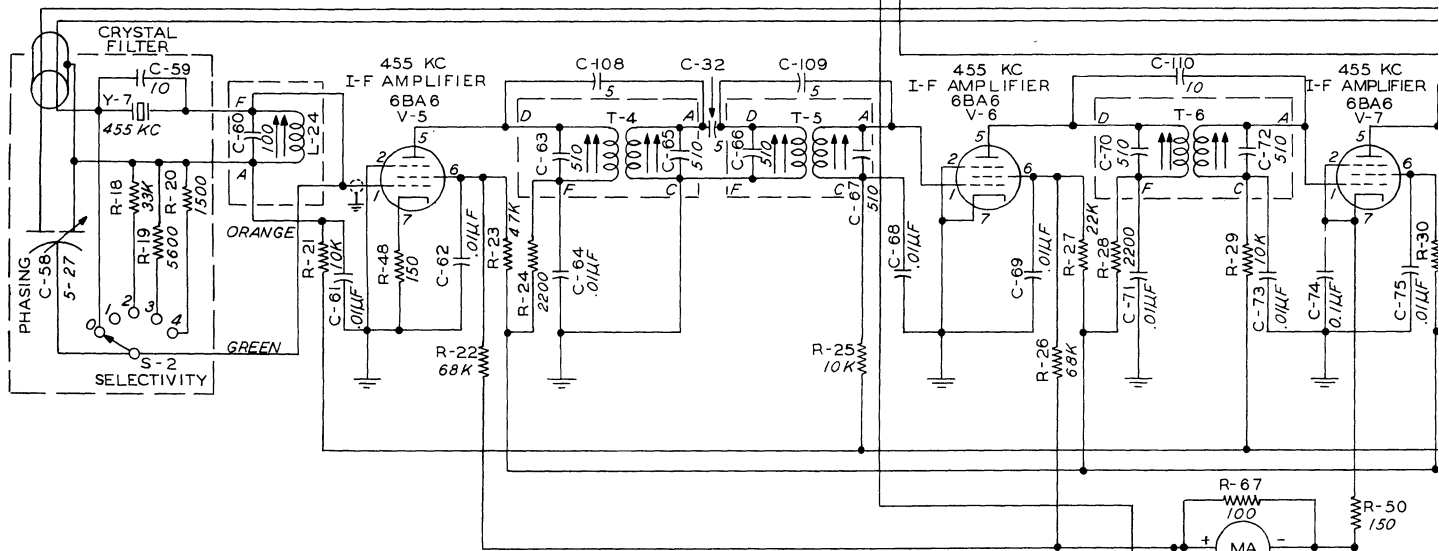
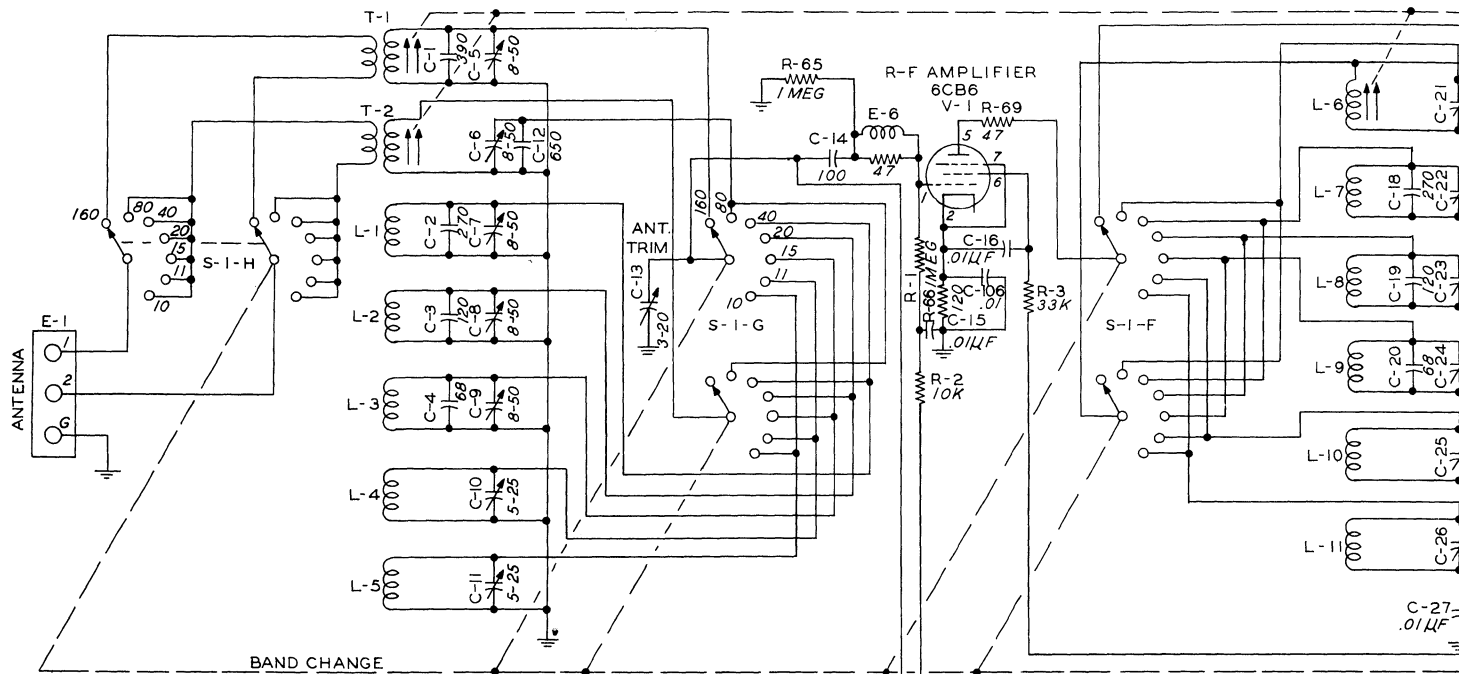

Figure 5-5. 75A-2 Receiver, Schematic Diagram

MAIN TUNING





NOTES:

1. UNLESS OTHERWISE INDICATED, ALL RESISTANCE VALUES ARE IN OHMS, ALL CAPACITANCE VALUES ARE IN MICROMICROFARADS.
2. TAP SWITCHES ARE SHOWN WITH ROTORS IN EXTREME COUNTER-CLOCKWISE POSITION

* ASTERISK INDICATES A CAPACITOR CHOSEN TO FULFILL REQUIREMENTS OF INDIVIDUAL OSCILLATOR

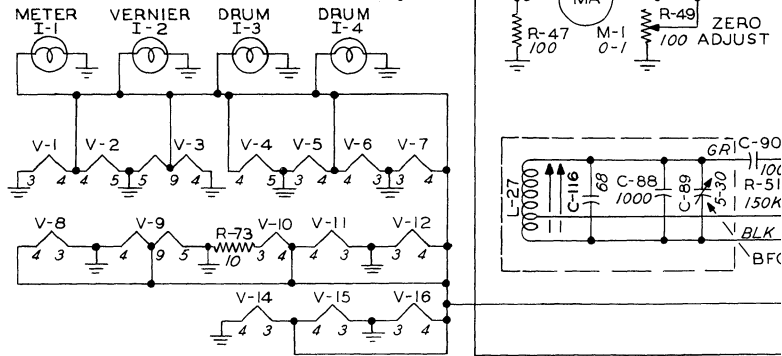

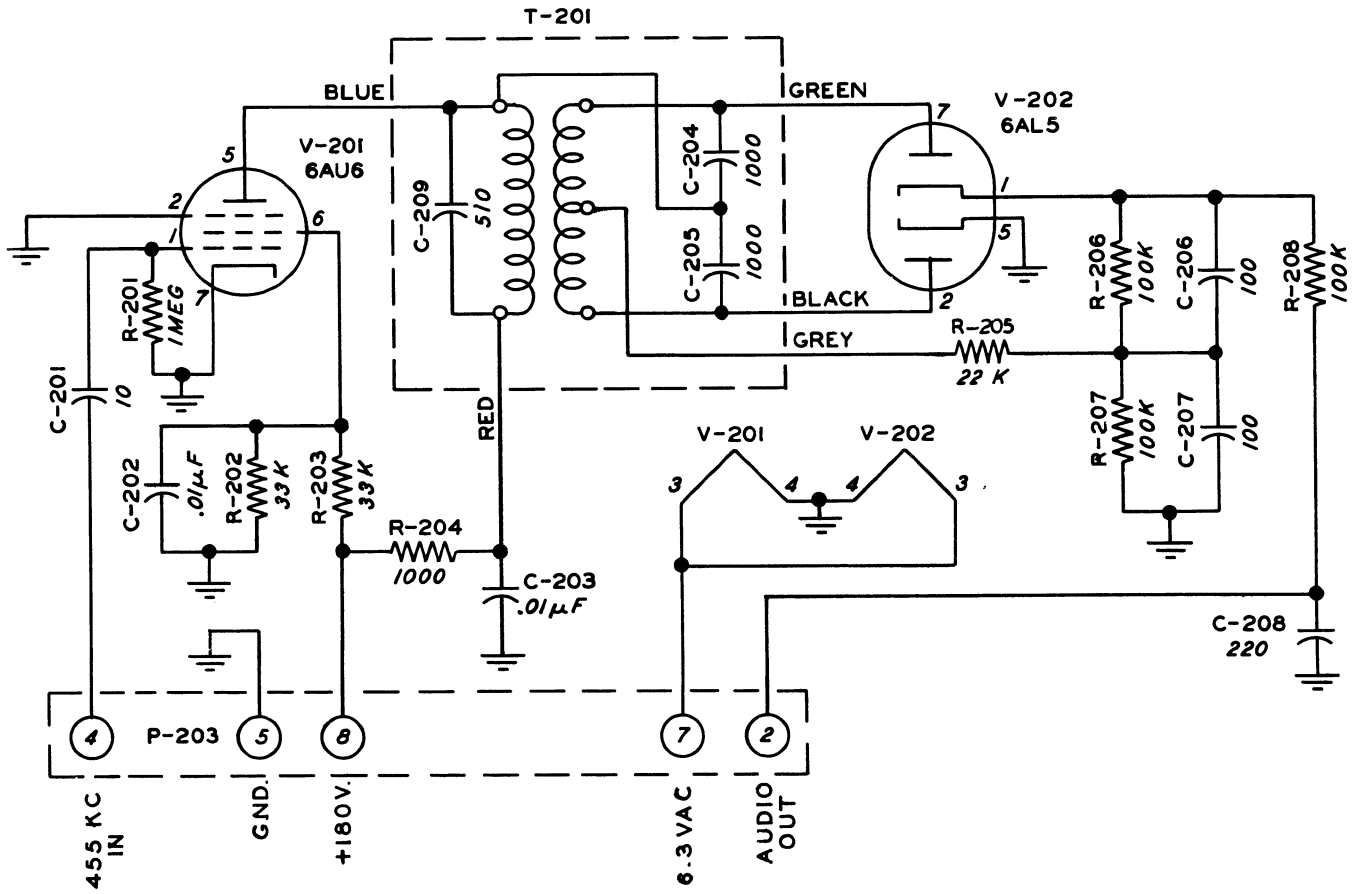

Figure 5-6. 148C-1 NBFM Adaptor Schematic Diagram

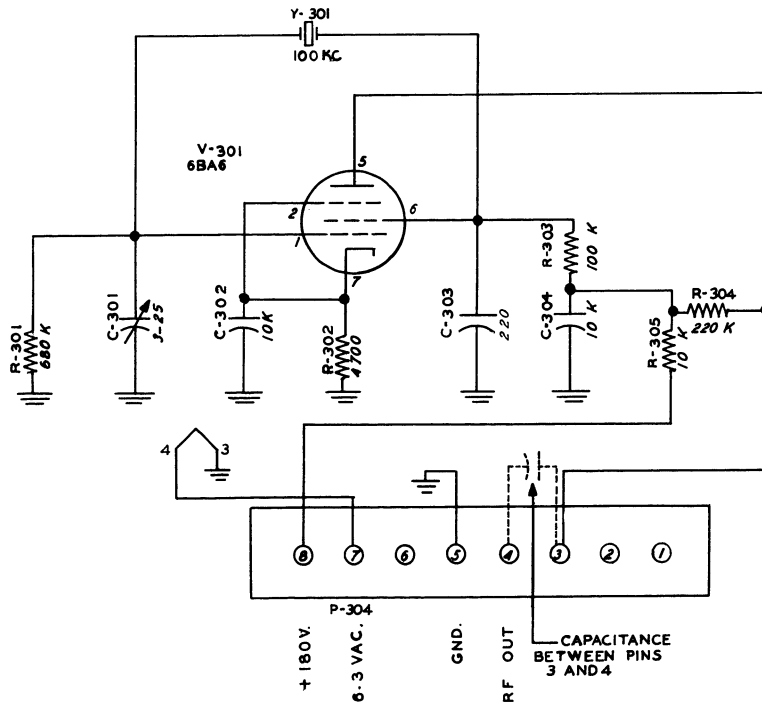
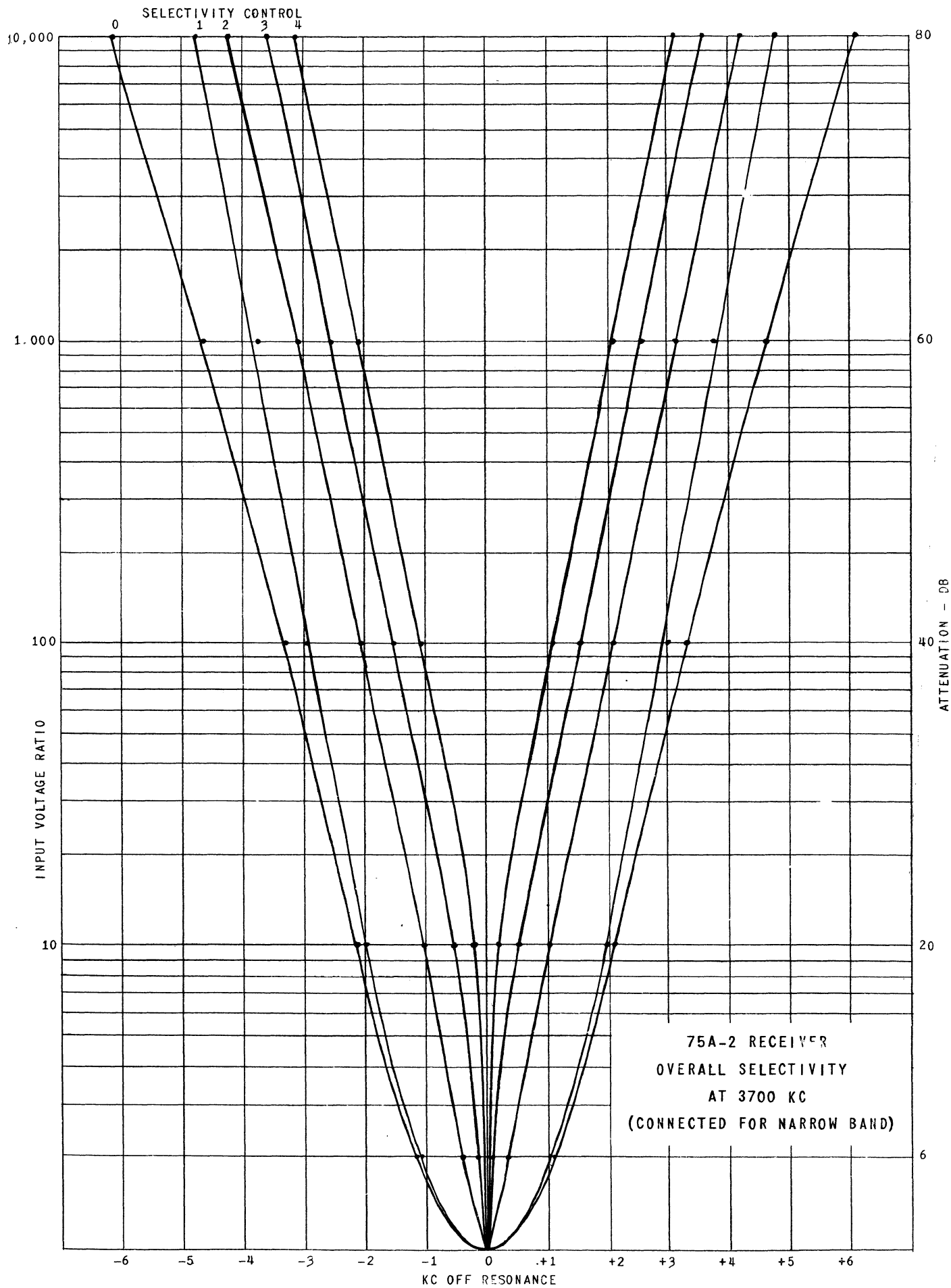
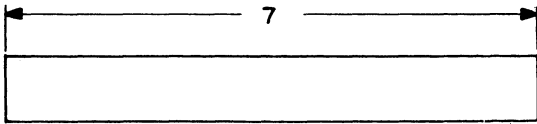
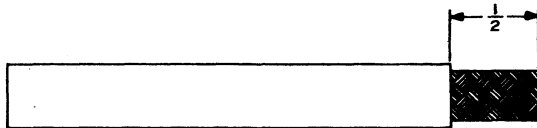

Figure 5-7 8R-1 Crystal Calibrator Schematic Diagram





CUT END OF CABLE EVEN.



REMOVE VINYL JACKET $\frac{1}{2}$ INCH —
DON'T NICK BRAID.

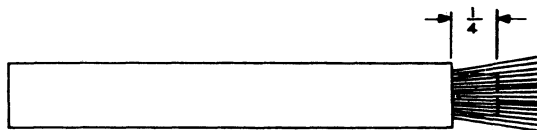

COMB OUT COPPER BRAID AS SHOWN.
BARE $\frac{1}{4}$ INCH OF CENTER CONDUCTOR—
DON'T NICK CONDUCTOR.

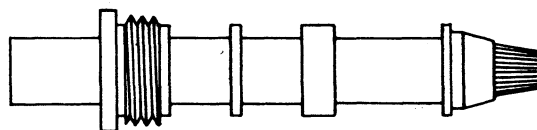

TAPER BRAID AS SHOWN. SLIDE NUT,
WASHER AND GASKET ON VINYL JACKET.
SLIDE CLAMP ON BRAID.

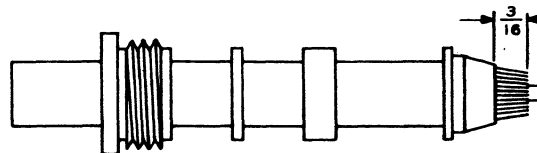

WITH CLAMP IN PLACE, TRIM BRAID
AS SHOWN.

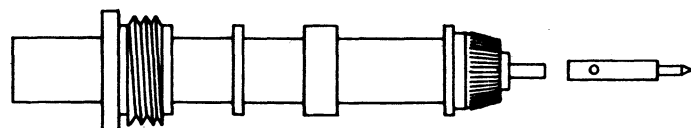

FOLD COPPER BRAID BACK ON CLAMP.
TIN CENTER CONDUCTOR,
USING MINIMUM AMOUNT OF
HEAT.

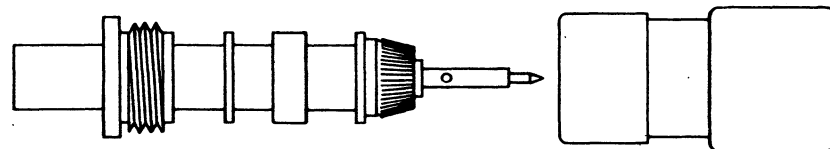

HOLDING CONTACT WITH PLIERS,
SOFT SOLDER CONTACT TO
CENTER CONDUCTOR. IT IS
IMPERATIVE THAT BACK END
OF CONTACT BE FLUSH WITH
POLYETHYLENE DIELECTRIC. DO
NOT USE EXCESS SOLDER. WIPE
CLEAN—SEE THAT END OF
CABLE INSULATOR IS CLEAN
AND FREE OF SOLDER, ROSIN
AND FOREIGN MATERIAL.

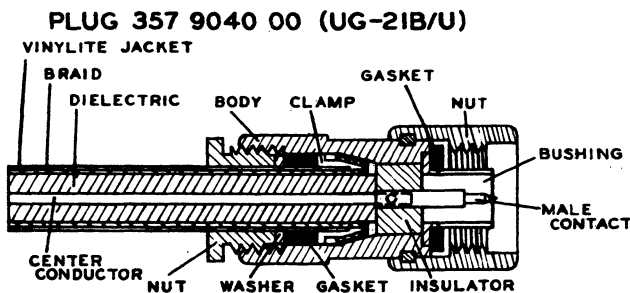

SLIDE BODY INTO PLACE CAREFULLY SO
THAT CENTER CONDUCTOR ENTERS HOLE
IN INSULATOR. FACE OF DIELECTRIC
MUST FIT FLUSH AGAINST IN-
SULATOR. PROPERLY TIGHTEN BODY
AND NUT WITH WRENCHES.

Figure 5-8. Assembling Plug UG-21B/U to Cable RG-8/U

SECTION VI

PARTS LIST

75A-2, RECEIVER

ITEM	CIRCUIT FUNCTION	DESCRIPTION	PART NUMBER
C-1	T-1 padding	CAPACITOR: mica; 390 mmf $\pm 2\%$, 500 WV	912 0535 00
C-2	L-1 padding	CAPACITOR: mica; 270 mmf $\pm 5\%$, 500 WV	912 0524 00
C-3	L-2 padding	CAPACITOR: mica; 120 mmf $\pm 10\%$, 500 WV	912 0501 00
C-4	L-3 padding	CAPACITOR: mica; 68 mmf $\pm 10\%$, 500 WV	912 0483 00
C-5	T-1 trimming	CAPACITOR, variable: ceramic; 8-50 mmf, 350 WV	917 1038 00
C-6	T-2 trimming	CAPACITOR, variable: ceramic; 8-50 mmf, 350 WV	917 1038 00
C-7	L-1 trimming	CAPACITOR, variable: ceramic; 8-50 mmf, 350 WV	917 1038 00
C-8	L-2 trimming	CAPACITOR, variable: ceramic; 8-50 mmf, 350 WV	917 1038 00
C-9	L-3 Trimming	CAPACITOR, variable: ceramic 8-50 mmf, 350 WV	917 1038 00
C-10	L-4 trimming	CAPACITOR, variable: ceramic; 5-25 mmf, 350 WV	917 1036 00
C-11	L-5 trimming	CAPACITOR, variable: ceramic; 5-25 mmf, 350 WV	917 1036 00
C-12	T-2 padding	CAPACITOR: mica; 650 mmf $\pm 2\%$, 500 WV	912 0548 00
C-13	Antenna trimmer	CAPACITOR, variable: air; 2.6-19.7 mmf	922 0033 00
C-14	V-1 grid blocking	CAPACITOR: mica; 100 mmf $\pm 10\%$, 500 WV	912 0495 00
C-15	V-1 grid decoupling	CAPACITOR: ceramic; 10,000 mmf, 350 WV	913 0566 00
C-16	V-1 screen by-pass	CAPACITOR: ceramic; 10,000 mmf, 350 WV	913 0566 00

ITEM	CIRCUIT FUNCTION	DESCRIPTION	PART NUMBER
C-17		Not used	
C-18	L-7 padding	CAPACITOR: Mica; 270 mmf $\pm 5\%$, 500 WV	912 0524 00
C-19	L-8 padding	CAPACITOR: mica; 120 mmf $\pm 10\%$, 500 WV	912 0501 00
C-20	L-9 padding	CAPACITOR: mica; 68 mmf $\pm 10\%$, 500 WV	912 0483 00
C-21	L-6 trimming	CAPACITOR, variable: ceramic; 8-50 mmf, 350 WV	917 1038 00
C-22	L-7 trimming	CAPACITOR, variable: ceramic; 8-50 mmf, 350 WV	917 1038 00
C-23	L-8 trimming	CAPACITOR, variable: ceramic; 8-50 mmf, 350 WV	917 1038 00
C-24	L-9 trimming	CAPACITOR, variable: ceramic; 8-50 mmf, 350 WV	917 1038 00
C-25	L-10 trimming	CAPACITOR, variable: ceramic; 5-25 mmf, 350 WV	917 1036 00
C-26	L-11 trimming	CAPACITOR, variable: ceramic; 5-25 mmf, 350 WV	917 1036 00
C-27	V-1 plate decoupling	CAPACITOR: ceramic; 10,000 mmf, 350 WV	913 0566 00
C-28	L-6 padding	CAPACITOR: mica; 650 mmf $\pm 2\%$, 500 WV	912 0548 00
C-29	V-2 grid blocking	CAPACITOR: mica; 18 mmf $\pm 5\%$, 500 WV	912 0440 00
C-30	V-2 cathode by-pass	CAPACITOR: ceramic; 10,000 mmf, 350 WV	913 0566 00
C-31	V-2 screen by-pass	CAPACITOR: ceramic; 10,000 mmf, 350 WV	913 0566 00
C-32	Band pass top coupling	CAPACITOR: ceramic; 5.0 mmf $\pm 1/4$ mmf, 500 WV	916 4384 00
C-33	V-2 injection coupling	CAPACITOR: mica; 100 mmf $\pm 10\%$, 500 WV	912 0495 00
C-34	V-3 plate to grid coupling	CAPACITOR: mica; 220 mmf $\pm 10\%$, 500 WV	912 0519 00
C-35	L-18 padding	CAPACITOR: mica; 56 mmf $\pm 10\%$, 500 WV	912 0477 00
C-36	V-3 plate decoupling	CAPACITOR: ceramic; 10,000 mmf, 350 WV	913 0566 00

Section VI

ITEM	CIRCUIT FUNCTION	DESCRIPTION	PART NUMBER
C-37	L-12 padding	CAPACITOR: mica; 220 mmf $\pm 10\%$, 500 WV	912 0519 00
C-38	L-13 padding	CAPACITOR: mica; 120 mmf $\pm 10\%$, 500 WV	912 0501 00
C-39	L-14 padding	CAPACITOR: mica; 120 mmf $\pm 10\%$, 500 WV	912 0501 00
C-40	L-15 padding	CAPACITOR: mica; 100 mmf $\pm 10\%$, 500 WV	912 0495 00
C-41	L-16 padding	CAPACITOR: mica; 47 mmf $\pm 10\%$, 500 WV	912 0471 00
C-42	L-17 padding	CAPACITOR: mica; 39 mmf $\pm 10\%$, 500 WV	912 0465 00
C-43	L-19 trimming	CAPACITOR, variable; 8-50 mmf, 350 WV	917 1038 00
C-44	L-18 padding	CAPACITOR: mica; 330 mmf $\pm 5\%$, 500 WV	912 0530 00
C-45	V-2 plate decoupling	CAPACITOR: ceramic; 10,000 mmf, 350 WV	913 0566 00
C-46	L-18 trimming	CAPACITOR, variable: ceramic; 8-50 mmf, 350 WV	917 1038 00
C-47		Not used	
C-48	Variable i-f coupling	CAPACITOR: ceramic; 4.0 mmf $\pm 1/2$ mmf, 500 WV	916 4381 00
C-49	Variable i-f coupling	CAPACITOR: ceramic; 1.0 mmf $\pm 1/4$ mmf, 500 WV	916 4368 00
C-50	L-22 padding	CAPACITOR: mica; 56 mmf $\pm 10\%$, 500 WV	912 0477 00
C-51	L-23 trimming	CAPACITOR, variable: ceramic; 8-50 mmf, 350 WV	917 1038 00
C-52	L-22 padding	CAPACITOR: mica; 330 mmf $\pm 5\%$, 500 WV	912 0530 00
C-53	L-22 trimming	CAPACITOR, variable: ceramic; 8-50 mmf, 350 WV	917 1038 00
C-54	V-4 cathode by-pass	CAPACITOR: ceramic; 10,000 mmf, 350 WV	913 0566 00
C-55	V-4 screen by-pass	CAPACITOR: ceramic; 10,000 mmf, 350 WV	913 0566 00
C-56	T-3 padding	CAPACITOR: 510 mmf, part of T-3	
C-57	V-4 plate decoupling	CAPACITOR: ceramic; 10,000 mmf, 350 WV	913 0566 00

ITEM	CIRCUIT FUNCTION	DESCRIPTION	PART NUMBER
C-58	Crystal filter phasing	CAPACITOR, variable: air; 3.5-27 mmf	922 0079 00
C-59	Filter crystal shunt	CAPACITOR: mica; 10 mmf $\pm 10\%$, 500 WV	912 0432 00
C-60	L-24 padding	CAPACITOR: 100 mmf, part of L-24	
C-61	V-5 grid decoupling	CAPACITOR: ceramic; 10,000 mmf, 350 WV	913 0566 00
C-62	V-5 screen by-pass	CAPACITOR: ceramic; 10,000 mmf, 350 WV	913 0566 00
C-63	T-4 primary padding	CAPACITOR: 510 mmf, part of T-4	
C-64	V-5 plate decoupling	CAPACITOR: ceramic; 10,000 mmf, 350 WV	913 0566 00
C-65	T-4 secondary padding	CAPACITOR: 510 mmf, part of T-4	
C-66	T-5 primary padding	CAPACITOR: 510 mmf, part of T-5	
C-67	T-5 secondary padding	CAPACITOR: 510 mmf, part of T-5	
C-68	V-6 grid decoupling	CAPACITOR: ceramic; 10,000 mmf, 350 WV	913 0566 00
C-69	V-6 screen by-pass	CAPACITOR: ceramic; 10,000 mmf, 350 WV	913 0566 00
C-70	T-6 primary padding	CAPACITOR: 510 mmf, part of T-6	
C-71	V-6 plate decoupling	CAPACITOR: ceramic; 10,000 mmf, 350 WV	913 0566 00
C-72	T-6 secondary padding	CAPACITOR: 510 mmf, part of T-6	
C-73	V-7 grid decoupling	CAPACITOR: ceramic; 10,000 mmf, 350 WV	913 0566 00
C-74	V-7 cathode by-pass	CAPACITOR: paper; .1 mf $\pm 20\%$, 150 WV	931 0239 00
C-75	V-7 screen by-pass	CAPACITOR: ceramic; 10,000 mmf, 350 WV	913 0566 00
C-76	T-7 primary padding	CAPACITOR: 510 mmf, part of T-7	
C-77	V-7 plate decoupling	CAPACITOR: ceramic; 10,000 mmf, 350 WV	913 0566 00
C-78	T-7 secondary padding	CAPACITOR: 510 mmf, part of T-7	
C-79	Detector r-f filter	CAPACITOR: mica; 330 mmf $\pm 5\%$, 500 WV	912 0530 00
C-80	AVC coupling	CAPACITOR: mica; 100 mmf $\pm 10\%$, 500 WV	912 0495 00
C-81	AVC filter	CAPACITOR: paper; .1 mf $\pm 10\%$, 150-200 WV	931 0333 00

ITEM	CIRCUIT FUNCTION	DESCRIPTION	PART NUMBER
C-82	AVC Amplifier	CAPACITOR: ceramic; 10,000 mmf, 350 WV	913 0566 00
C-83	V-9 cathode coupling	CAPACITOR: paper; .5 mf +20% -10%, 200 WV	931 0169 00
C-84	Noise limiter filter	CAPACITOR: paper; .1 mf \pm 10%, 150-200 WV	931 0333 00
C-85	V-9 audio input coupling	CAPACITOR: ceramic; 10,000 mmf, 350 WV	913 0566 00
C-86	V-11 audio input coupling	CAPACITOR: ceramic; 10,000 mmf, 350 WV	913 0566 00
C-87	CW noise limiter audio input coupling	CAPACITOR: ceramic; 10,000 mmf, 350 WV	913 0566 00
C-88	BFO (L-27) padding	CAPACITOR: 1000 mmf, part of L-27	
C-89	BFO (L-27) pitch adjust	CAPACITOR: 5-30 mmf, part of L-27	
C-90	BFO (V-12) grid blocking	CAPACITOR: mica; 100 mmf \pm 10%, 500 WV	912 0495 00
C-91	V-12 screen by-pass	CAPACITOR: ceramic; 10,000 mmf, 350 WV	913 0566 00
C-92	V-12 output coupling	CAPACITOR: mica; 10 mmf \pm 10%, 500 WV	912 0432 00
C-93	V-12 screen decoupling	CAPACITOR: ceramic; 10,000 mmf, 350 WV	913 0566 00
C-94	Back bias filter	CAPACITOR: electrolytic; 50 mf -10% +100%, 150 WV	183 1045 00
C-95	C-95A and C-95B	CAPACITOR: electrolytic; dual sect, 40 mf -15% +100% ea sect, 450 WV	183 1009 00
C-95A	Power supply filter	CAPACITOR: 40 mf; part of C-95	
C-95B	Power supply filter	CAPACITOR: 40 mf; part of C-95	
C-96	Back bias by-pass	CAPACITOR: paper; .1 mf \pm 20%, 150 WV	931 0239 00
C-97	V-9 cathode by-pass	CAPACITOR: electrolytic; 20 mf -10% +100%, 150 WV	183 1042 00
C-98	AVC time constant	CAPACITOR: paper; .1 mf \pm 10%, 150-200 WV	931 0333 00

ITEM	CIRCUIT FUNCTION	DESCRIPTION	PART NUMBER
C-99	V-11 plate stabilizing	CAPACITOR: ceramic; 10,000 mmf, 350 WV	913 0566 00
C-100	VFO plate line by-pass	CAPACITOR: paper; .1 mf $\pm 20\%$, 150 WV	931 0239 00
C-101	V-4 screen and plate decoupling	CAPACITOR: ceramic; 10,000 mmf, 350 WV	913 0566 00
C-102	B+ decoupling	CAPACITOR: ceramic; 10,000 mmf, 350 WV	913 0566 00
C-103	B+ by-pass	CAPACITOR: paper; .5 mf $+20\%$ -10% , 600 WV	931 0205 00
C-104	Tweet trap series	CAPACITOR: mica; 270 mmf $\pm 5\%$, 500 WV	912 0524 00
C-105	T-7 top coupling	CAPACITOR: mica; 10 mmf $\pm 10\%$, 500 WV	912 0432 00
C-106	V-1 cathode by-pass	CAPACITOR: ceramic; 10,000 mmf, 350 WV	913 0566 00
C-107	AC line filter	CAPACITOR: ceramic; 10,000 mmf, 350 WV	913 0566 00
C-108	T-4 coupling	CAPACITOR: ceramic; 5 mmf $\pm 1/2$ mmf, 500 WV	916 4385 00
C-109	T-5 coupling	CAPACITOR: ceramic; 5 mmf $\pm 1/2$ mmf, 500 WV	916 4385 00
C-110	T-6 coupling	CAPACITOR: mica; 10 mmf $\pm 10\%$, 500 WV	912 0432 00
C-111	V-11 grid filter	CAPACITOR: mica; 100 mmf $\pm 10\%$, 500 WV	912 0495 00
C-114	V-9 grid filter	CAPACITOR: mica; 100 mmf $\pm 10\%$, 500 WV	912 0495 00
C-115	Decoupling	CAPACITOR: ceramic; 10,000 mmf, 350 WV	913 0566 00
C-116	BFO (L-27) padding	CAPACITOR: 68 mmf (part of L-27)	
E-1	Antenna connector	STRIP: terminal; 3 screw term on bakelite board	306 0033 00
E-3	Speaker connector	STRIP: terminal; 4 screw term on bakelite board	306 0034 00
E-4	Meeting-stand by connector	STRIP: terminal; 4 screw term on bakelite board	306 0034 00
E-6		PARASITIC SUPPRESSOR: 47 ohm; #24 bus wire	504 7064 001
F-1	Line fuse	FUSE: cartridge; 2 amp, 250 V	264 4070 00

ITEM	CIRCUIT FUNCTION	DESCRIPTION	PART NUMBER
I-1	Meter illuminating	LAMP: Part of M-1	
I-2	Vernier dial	LAMP: pilot light bulb w/miniature bayonet base	262 3240 00
I-3	Megacycle dial	LAMP: pilot light bulb w/miniature bayonet base	262 3240 00
I-4	Megacycle dial	LAMP: pilot light bulb w/miniature bayonet base	262 3240 00
J-1	Phones jack	JACK: phone; 2 circuit, for 1/4" diam plug	360 0025 00
J-2		Not used	
J-3		Not used	
J-4	NBFM adaptor	SOCKET: octal	220 1013 00
J-5	Crystal calibrator adaptor	SOCKET: octal	220 1013 00
L-1	40 meter r-f inductance	COIL, RF: single wnd, single layer wnd, 18 turns #28 AWG DS wire	504 7000 001
L-2	20 meter r-f inductance	COIL, RF: single wnd, single layer wnd, 9 turns #28 AWG DS wire	504 6999 001
L-3	15 meter r-f inductance	COIL, RF: single wnd, single layer wnd, 7 turns #28 AWG DS wire	504 6997 001
L-4	11 meter r-f inductance	COIL, RF: single wnd, single layer wnd, 12 turns #28 AWG DS wire	504 6996 001
L-5	10 meter r-f inductance	COIL, RF: single wnd, single layer wnd, 12 turns #28 AWG DS wire	504 6996 001
L-6	80 meter mixer inductance	COIL, RF: single wnd, single layer wnd, 16 turns #26 AWG E wire	504 7037 001
L-7	40 meter mixer inductance	COIL, RF: single wnd, single layer wnd, 18 turns #28 AWG DS wire	504 7000 001
L-8	20 meter mixer inductance	COIL, RF: single wnd, single layer wnd, 9 turns #28 AWG DS wire	504 6999 001

ITEM	CIRCUIT FUNCTION	DESCRIPTION	PART NUMBER
L-9	15 meter mixer inductance	COIL, RF: single wnd, single layer wnd, 7 turns #28 AWG DS wire	504 6997 001
L-10	11 meter mixer inductance	COIL, RF: single wnd, single layer wnd, 12 turns #28 AWG DS wire	504 6996 001
L-11	10 meter mixer inductance	COIL, RF: single wnd, single layer wnd, 12 turns #28 AWG DS wire	504 6996 001
L-12	80 meter crystal inductance	COIL, RF: 5.7 mc, single wnd, single layer wnd, 16 turns #28 AWG E wire	504 7004 001
L-13	40 meter crystal inductance	COIL, RF: single wnd, single layer wnd, 12 turns #28 AWG DS wire	504 6998 001
L-14	20 meter crystal inductance	COIL, RF: single wnd, single layer wnd, 7 turns #28 AWG DS wire	504 6997 001
L-15	15 meter crystal inductance	COIL, RF: 23, 31, 33 mc; single wnd, single layer wnd, 5 turns #28 AWG DS wire	504 7001 001
L-16	11 meter crystal inductance	COIL, RF: 23, 31, 33 mc; single wnd, single layer wnd, 5 turns #28 AWG DS wire	504 7001 001
L-17	10 meter crystal inductance	COIL, RF: 23, 31, 33 mc; single wnd, single layer wnd, 5 turns #28 AWG DS wire	504 7001 001
L-18	Low freq. variable i-f inductance	COIL, RF: 1.5-2.5 mc, single wnd, single layer wnd, 52 turns #32 AWG E wire	504 7005 001
L-19	High freq. variable i-f inductance	COIL, RF: single pie, duo lat wnd, 94 turns litz wire	504 7002 001
L-20	Tweet trap inductance	COIL, RF: choke, 500 uh; 3 pie universal wnd, 112 turns ea pie	240 0073 00
L-21	Variable i-f trimmer inductance	COIL, RF: 5.7 mc, single wnd, single layer wnd, 16 turns #28 AWG E wire	505 1738 001
L-22	Low freq. variable i-f inductance	COIL, RF: 1.5-2.5 mc, single wnd, single layer wnd, 52 turns #32 AWG E wire	504 7005 001
L-23	High freq. variable i-f inductance	COIL, RF: single pie, duo lat wnd, 94 turns litz wire	504 7002 001
L-24	455 KC i-f input	COIL, RF: crystal filter grid; freq range 440-470 kc (incl. C-60)	278 0085 00

ITEM	CIRCUIT FUNCTION	DESCRIPTION	PART NUMBER
L-27	BFO inductance	COIL, RF: BFO; freq. range 440-470 kc (incl C-88, C-89)	278 0082 00
L-28	Power supply filter	REACTOR: filter; 5.0 hy at 0.080 amp	668 0019 00
L-29	Power supply filter	REACTOR: filter; 3.0 hy at 0.120 amp	668 0020 00
M-1	"S" meter	METER: signal level; 1 ma DC, 50 ohm +20% DC resistance, illuminated dial (incl. I-1)	458 0044 00
P-1		CONNECTOR: not used	
P-2	A-C power cord and plug	CONNECTOR: two conductor flexible AC cord; std AC plug	426 1003 00
R-1	V-1 grid	RESISTOR: 1.0 megohm $\pm 10\%$, 1/2 w	745 1212 00
R-2	V-1 grid decoupling	RESISTOR: 10,000 ohm $\pm 10\%$, 1/2 w	745 1128 00
R-3	V-1 screen	RESISTOR: 33,000 ohm $\pm 10\%$, 1/2 w	745 1149 00
R-4	V-3 stabilizing	RESISTOR: 47 ohm $\pm 10\%$, 1/2 w	745 1030 00
R-5	V-1 plate decoupling	RESISTOR: 2200 ohm $\pm 10\%$, 1/2 w	745 1100 00
R-6	V-2 grid	RESISTOR: .47 megohm $\pm 10\%$, 1/2 w	745 1198 00
R-7	V-2 cathode	RESISTOR: 68 ohm $\pm 10\%$, 1/2 w	745 1037 00
R-8	V-2 screen	RESISTOR: 4700 ohm $\pm 10\%$, 2 w	745 9125 00
R-9	V-3 cathode	RESISTOR: 330 ohm $\pm 10\%$, 1/2 w	745 1065 00
R-10	V-3 cathode	RESISTOR: 330 ohm $\pm 10\%$, 1/2 w	745 1065 00
R-11	V-3 grid	RESISTOR: 4700 ohm $\pm 10\%$, 1/2 w	745 1114 00
R-12	V-3 plate decoupling	RESISTOR: 2200 ohm $\pm 10\%$, 1/2 w	745 1100 00
R-13	V-2 plate decoupling	RESISTOR: 2200 ohm $\pm 10\%$, 1/2 w	745 1100 00
R-14	V-4 grid	RESISTOR: .10 megohm $\pm 10\%$, 1/2 w	745 1170 00
R-15	V-4 cathode	RESISTOR: 68 ohm $\pm 10\%$, 1/2 w	745 1037 00
R-16	V-4 screen dropping	RESISTOR: 8200 ohm $\pm 10\%$, 2 w	745 9136 00

ITEM	CIRCUIT FUNCTION	DESCRIPTION	PART NUMBER
R-17	V-4 plate decoupling	RESISTOR: 2200 ohm $\pm 10\%$, 1/2 w	745 1100 00
R-18	Sensitivity control	RESISTOR: 33,000 ohm $\pm 10\%$, 1/2 w	745 1149 00
R-19	Sensitivity	RESISTOR: 5600 ohm $\pm 10\%$, 1/2 w	745 1118 00
R-20	Sensitivity	RESISTOR: 1500 ohm $\pm 10\%$, 1/2 w	745 1093 00
R-21	V-5 grid decoupling	RESISTOR: 10,000 ohm $\pm 10\%$, 1/2 w	745 1128 00
R-22	V-5 screen voltage divider	RESISTOR: 68,000 ohm $\pm 10\%$, 1/2 w	745 1163 00
R-23	V-5 screen dropping	RESISTOR: 47,000 ohm $\pm 10\%$, 1/2 w	745 1156 00
R-24	V-5 plate decoupling	RESISTOR: 2200 ohm $\pm 10\%$, 1/2 w	745 1100 00
R-25	V-6 grid decoupling	RESISTOR: 10,000 ohm $\pm 10\%$, 1/2 w	745 1128 00
R-26	V-6 screen voltage divider	RESISTOR: 68,000 ohm $\pm 10\%$, 1/2 w	745 1163 00
R-27	V-6 screen dropping	RESISTOR: 22,000 ohm $\pm 10\%$, 1/2 w	745 1142 00
R-28	V-6 plate decoupling	RESISTOR: 2200 ohm $\pm 10\%$, 1/2 w	745 1100 00
R-29	V-7 grid decoupling	RESISTOR: 10,000 ohm $\pm 10\%$, 1/2 w	745 1128 00
R-30	V-7 screen dropping	RESISTOR: 47,000 ohm $\pm 10\%$, 1/2 w	745 1156 00
R-31	V-7 plate decoupling	RESISTOR: 2200 ohm $\pm 10\%$, 1/2 w	745 1100 00
R-32	AVC rectifier load	RESISTOR: .10 megohm $\pm 10\%$, 1/2 w	745 1170 00
R-33	AVC amplr. input filter	RESISTOR: .47 megohm $\pm 10\%$, 1/2 w	745 1198 00
R-34	AVC amplr. input filter	RESISTOR: 0.12 megohm $\pm 10\%$, 1/2 w	745 1174 00
R-35	AVC amplr. stabilizing	RESISTOR: .10 megohm $\pm 10\%$, 1/2 w	745 1170 00
R-36	Back bias	RESISTOR: 100 ohm $\pm 10\%$, 2 w	745 5044 00
R-37	Back bias	RESISTOR: wire wound; 350 ohm $\pm 10\%$, 10 w	710 1350 20
R-38	Back bias	RESISTOR: 120 ohm $\pm 10\%$, 2 w	745 5048 00

ITEM	CIRCUIT FUNCTION	DESCRIPTION	PART NUMBER
R-39	Noise limiter	RESISTOR: 47,000 ohm $\pm 10\%$, 1/2 w	745 1156 00
R-40	Noise limiter	RESISTOR: 47,000 ohm $\pm 10\%$, 1/2 w	745 1156 00
R-41	Noise limiter cathode	RESISTOR: .47 megohm $\pm 10\%$, 1/2 w	745 1198 00
R-42	Noise limiter	RESISTOR: .47 megohm $\pm 10\%$, 1/2 w	745 1198 00
R-43	V-9 cathode	RESISTOR: 6800 ohm $\pm 10\%$, 1/2 w	745 1121 00
R-44	Audio gain control	RESISTOR, variable: 500,000 ohm $\pm 20\%$, 1/4 w	376 4499 00
R-45	V-9 plate	RESISTOR: .22 megohm $\pm 10\%$, 1/2 w	745 1184 00
R-46	V-11 grid	RESISTOR: .10 megohm $\pm 10\%$, 1/2 w	745 1170 00
R-47	S meter bridge	RESISTOR: 100 ohm $\pm 10\%$, 1/2 w	745 1044 00
R-48		RESISTOR: 150 ohm $\pm 10\%$, 1/2 w	745 1051 00
R-49	S meter zero adjust	RESISTOR, variable: 100 ohm $\pm 10\%$, 1 w	377 0122 00
R-50	V-7 cathode	RESISTOR: 150 ohm $\pm 10\%$, 1/2 w	745 1051 00
R-51	V-12 grid	RESISTOR: .15 megohm $\pm 10\%$, 1/2 w	745 1177 00
R-52	V-12 plate dropping	RESISTOR: .10 megohm $\pm 10\%$, 1/2 w	745 1170 00
R-53	V-12 screen dropping	RESISTOR: 33,000 ohm $\pm 10\%$, 1/2 w	745 1149 00
R-54	V-12 plate decoupling	RESISTOR: 10,000 ohm $\pm 10\%$, 1/2 w	745 1128 00
R-55	AVC filter	RESISTOR: 220,000 ohm $\pm 10\%$, 1/2 w	745 1184 00
R-56	AVC amplr. plate dropping	RESISTOR: 15,000 ohm $\pm 5\%$, 1/2 w	745 1134 00
R-57	R-F gain control	RESISTOR, variable: 10,000 ohm $\pm 10\%$, 1/2 w	376 3522 00
R-58	R-F gain series	RESISTOR: 560 ohm $\pm 5\%$, 1/2 w	745 1075 00
R-59	Audio load	RESISTOR: 10 ohm $\pm 10\%$, 2 w	745 5002 00
R-60	V-2 injection grid	RESISTOR: 22,000 ohm $\pm 10\%$, 1/2 w	745 1142 00

ITEM	CIRCUIT FUNCTION	DESCRIPTION	PART NUMBER
R-61	V-9 cathode	RESISTOR: 2200 ohm $\pm 10\%$, 1/2 w	745 1100 00
R-62	CW LIMITER control	RESISTOR, variable: 10,000 ohm, $\pm 20\%$ 1/2 w	376 4022 00
R-63	CW limiter voltage divider	RESISTOR: 68,000 ohm $\pm 10\%$, 1 w	745 3163 00
R-64	B+ isolation	RESISTOR: 1000 ohm $\pm 10\%$, 1 w	745 3086 00
R-65	V-1 grid voltage divider	RESISTOR: 1 megohm $\pm 10\%$, 1/2 w	745 1212 00
R-66	V-1 cathode	RESISTOR: 120 ohm $\pm 10\%$, 1/2 w	745 1048 00
R-67	M-1 shunt	RESISTOR: 100 ohm $\pm 10\%$, 1/2 w	745 1044 00
R-68	T-3 primary load	RESISTOR: .10 megohm $\pm 10\%$, 1/2 w	745 1170 00
R-69	V-1 stabilizer	RESISTOR: 47 ohm $\pm 10\%$, 1/2 w	745 1030 00
R-70	Regulator dropping	RESISTOR: 2500 ohm $\pm 10\%$, 10 w size	710 0030 00
R-71	Bias adjust	RESISTOR: 3900 ohm p/m 10%, 1 w	745 3111 00
R-72	Bias adjust	RESISTOR: 3900 ohm p/m 10%, 1 w	745 3111 00
R-73	Filament dropping for V-10	RESISTOR: 10 ohm p/m 10%, 1 w	745 3002 00
S-1	S-1A, B, C, D, E, F, G, and H	SWITCH, rotary: consists of:	
S-1A	Variable i-f selecting	SWITCH, rotary: 1 circuit, 7 position, shorting	269 1294 00
S-1B	Variable i-f selecting	SWITCH, rotary: 1 circuit, 7 position, shorting	269 1294 00
S-1C	Variable i-f selecting	SWITCH, rotary: 1 circuit, 7 position, shorting	269 1294 00
S-1D	Crystal coil selecting	SWITCH, rotary: 1 circuit, 6 position, shorting	269 1293 00
S-1E	Crystal selector	SWITCH, rotary: 1 circuit, 6 position, shorting	269 1293 00

ITEM	CIRCUIT FUNCTION	DESCRIPTION	PART NUMBER
S-1F	Mixer grid coil selecting	SWITCH, rotary: 1 circuit, 7 position shorting	269 1296 00
S-1G	R-F amplr. grid coil selecting	SWITCH, rotary: 1 circuit, 7 position, shorting	269 1296 00
S-1H	Antenna coil selecting	SWITCH, rotary: 1 circuit, 7 position, shorting	269 1295 00
S-2	SELECTIVITY selector	SWITCH, rotary: band change; 1 circuit, 5 position, shorting	259 0415 00
S-3	CW - AM - FM selecting	SWITCH, rotary: 1 circuit, 3 position, shorting	259 0416 00
S-4	LIMITER	SWITCH, rotary: 2 circuit, 3 position, non-shorting	259 0417 00
S-5	OFF-STAND BY-ON	SWITCH, rotary: band change; 2 circuit, 3 position, shorting	259 0363 00
T-1	160 meter r-f coil assembly	COIL, RF: two wnd, single layer wnd, one wnd w/ 51 turns, other wnd w/4 turns	504 7038 002
T-2	80 meter r-f coil assembly	COIL, RF: two wnd, single layer wnd, one wnd w/ 16 turns, other wnd w/ 3 turns	504 7039 002
T-3	Second mixer plate coil assembly	TRANSFORMER: crystal filter plate; freq. range 440-470 kc (incl. C-56)	278 0083 00
T-4	V-5 plate coil assembly	TRANSFORMER: intermediate freq. 455; freq. range 440-470 kc (incl C-63, C-65)	278 0084 00
T-5	V-6 grid coil assembly	TRANSFORMER: intermediate freq. 455; freq. range 440-470 kc (incl C-66, C-67)	278 0084 00
T-6	V-6, V-7 i-f coil assembly	TRANSFORMER: intermediate freq. 455; freq. range 440-470 kc (incl C-70, C-72)	278 0084 00
T-7	V-7, V-8 i-f coil assembly	TRANSFORMER: intermediate freq. 455; freq. range 440-470 kc (incl C-76, C-78)	278 0084 00
T-8	Audio output	TRANSFORMER: audio output; pri 5000 ohm, secd 500 ohm tapped at 4 ohm, 2500 TV	667 0018 00
T-9	Power supply	TRANSFORMER, power: pri 117 v, secd #1; 700 v CT, secd #2: 5.0 v secd #3: 6.3 v, 2500 TV, 50/60 cps	662 0017 00

ITEM	CIRCUIT FUNCTION	DESCRIPTION	PART NUMBER
V-1	RF amplr.	TUBE: type 6CB6; pentode	255 0207 00
V-2	First mixer	TUBE: type 6BA7; pentagrid	255 0209 00
V-3	Crystal oscillator	TUBE: type 12AT7; double triode	255 0205 00
V-4	Second mixer	TUBE: type 6BA7; pentagrid	255 0209 00
V-5	I-f amplifier	TUBE: type 6BA6; pentode	255 0185 00
V-6	I-f amplifier	TUBE: type 6BA6; pentode	255 0185 00
V-7	I-f amplifier	TUBE: type 6BA6; pentode	255 0185 00
V-8	Detector and AVC rectifier	TUBE: type 6AL5; double diode	257 0018 00
V-9	AVC and AF amplifier	TUBE: type 12AX7; double triode	255 0201 00
V-10	Automatic noise limi- ter	TUBE; type 6AL5; double diode	257 0018 00
V-11	Audio output	TUBE: type 6AQ5; beam pentode	255 0195 00
V-12	Beat frequency oscilla- tor	TUBE: type 6BA6; pentode	255 0185 00
V-13	Power supply rectifier	TUBE: type 5Y3GT; full wave rectifier	255 0157 00
V-16	CW noise limiter	TUBE: type 6AL5; double diode	257 0018 00
V-17	Voltage Regulator	TUBE: type 0A2;	257 0252 00
XF-1	Fuse holder	FUSE HOLDER: extractor post for 3 AG fuse	265 1002 00
XI-2	Socket for I-2	LAMPHOLDER: for use w/ T-3 1/4 miniature bayonet base bulb	262 0150 00
XI-3, XI-4	Socket for I-3 and I-4	LAMPHOLDER: bracket for miniature bayonet base bulb	262 1210 00
XV-1	Socket for V-1	SOCKET, tube: 7 contact miniature	220 1034 00
XV-2	Socket for V-2	SOCKET, tube: 9 contact miniature	220 1062 00
XV-3	Socket for V-3	SOCKET, tube: 9 contact miniature	220 1062 00

ITEM	CIRCUIT FUNCTION	DESCRIPTION	PART NUMBER
XV-4	Socket for V-4	SOCKET, tube: 9 contact miniature	220 1062 00
XV-5	Socket for V-5, V-6,	SOCKET, tube: 7 contact miniature	220 1046 00
XV-6	V-7, V-8		
XV-7,			
XV-8			
XV-9	Socket for V-9	SOCKET, tube: 9 contact miniature	220 1053 00
XV-10	Socket for V-10,	SOCKET, tube: 7 contact miniature	220 1046 00
XV-11	V-11, V-12		
XV-12			
XV-13	Socket for V-13	SOCKET, tube: octal	220 1013 00
XV-16, XV-17	Socket for V-16, V-17	SOCKET, tube: 7 contact miniature	220 1034 00
XY-1 XY-2 XY-3 XY-4 XY-5 XY-6	Socket for Y-1, Y-2, Y-3, Y-4, Y-5, Y-6	SOCKET, crystal: 6 crystal holders on phenolic board	504 7063 002
Y-1	80 meter band crystal	CRYSTAL: 5.7 mc	291 8070 00
Y-2	40 meter band crystal	CRYSTAL: 9.3 mc	291 8071 00
Y-3	20 meter band crystal	CRYSTAL: 16.5 mc	291 8072 00
Y-4	15 meter band crystal	CRYSTAL: 23.3 mc	291 8073 00
Y-5	11 meter band crystal	CRYSTAL: 31.455 mc	291 8074 00
Y-6	10 meter band crystal	CRYSTAL: 33.455 mc	291 8075 00
Y-7	455 kc filter crystal	CRYSTAL: 455 kc	291 5957 00
70E-12	OSCILLATOR (VFO)	This unit has been dehydrated and hermetically sealed, and should be returned to the Collins Radio Company if servicing is required.	

148C-1 NBFM ADAPTER

ITEM	CIRCUIT FUNCTION	DESCRIPTION	PART NUMBER
C-201	Input coupling	CAPACITOR: mica; 10 mmf $\pm 10\%$, 500 WV	912 0432 00
C-202	Screen by-pass	CAPACITOR: ceramic; 10,000 mmf, 350 WV	913 0566 00
C-203	V-201 plate decoupling	CAPACITOR: ceramic; 10,000 mmf, 350 WV	913 0566 00
C-204	T-201 secondary tuning	CAPACITOR: 1000 mmf, part of T-201	
C-205	T-201 secondary tuning	CAPACITOR: 1000 mmf, part of T-201	
C-206	Output r-f filter	CAPACITOR: mica; 100 mmf $\pm 10\%$, 500 WV	912 0495 00
C-207	Output r-f filter	CAPACITOR: mica; 100 mmf $\pm 10\%$, 500 WV	912 0495 00
C-208	De-emphasis	CAPACITOR: mica; 220 mmf $\pm 10\%$, 500 WV	912 0519 00
C-209		CAPACITOR: 510 mmf, part of T-201	
P-203	Power connector	CONNECTOR, receptacle: 8 male contacts	369 1013 00
R-201	V-201 grid	RESISTOR: 1.0 megohm $\pm 10\%$, 1/2 w	745 1212 00
R-202	V-201 screen bleeder	RESISTOR: 33,000 ohm $\pm 10\%$, 1/2 w	745 1149 00
R-203	V-201 screen dropping	RESISTOR: 33,000 ohm $\pm 10\%$, 1/2 w	745 1149 00
R-204	V-201 plate decoupling	RESISTOR: 1000 ohm $\pm 10\%$, 1/2 w	745 1086 00
R-205	V-202 plate decoupling	RESISTOR: 22,000 ohm $\pm 10\%$, 1/2 w	745 1142 00
R-206	Diode load	RESISTOR: .10 megohm $\pm 10\%$, 1/2 w	745 1170 00
R-207	Diode load	RESISTOR: .10 megohm $\pm 10\%$, 1/2 w	745 1170 00
R-208	De-emphasis	RESISTOR: .10 megohm $\pm 10\%$, 1/2 w	745 1170 00
T-201	Discriminator	TRANSFORMER: narrow band discriminator; 455 kc center frequency	278 0089 00
V-201	Limiter	TUBE: type 6AU6; pentode	255 0202 00
V-202	Discriminator	TUBE: type 6AL5; twin diode rectifier	257 0018 00
XV-201 XV-202	Socket for V-201, V-202	SOCKET, tube: 7 pin miniature	220 1046 00

8R-1 CRYSTAL CALIBRATOR

ITEM	CIRCUIT FUNCTION	DESCRIPTION	PART NUMBER
C-301	Calibration oscillator zero adj	CAPACITOR, variable: ceramic; 5-25 mmf, 350 WV	917 1036 00
C-302	Cathode by-pass	CAPACITOR: ceramic; 10,000 mmf, 350 WV	913 0566 00
C-303	Screen by-pass	CAPACITOR: mica; 220 mmf $\pm 10\%$, 500 WV	912 0519 00
C-304	Screen decoupling	CAPACITOR: ceramic; 10,000 mmf, 350 WV	913 0566 00
P-304	Power connector	CONNECTOR, receptacle: 8 male contacts	369 1013 00
R-301	Grid	RESISTOR: 0.68 meg $\pm 10\%$, 1/2 w	745 1205 00
R-302	Cathode	RESISTOR: 4700 ohm $\pm 10\%$, 1/2 w	745 1114 00
R-303	Screen dropping	RESISTOR: .10 megohm $\pm 10\%$, 1/2 w	745 1170 00
R-304	Screen voltage divider	RESISTOR: .22 megohm $\pm 10\%$, 1/2 w	745 1184 00
R-305	Decoupling	RESISTOR: 10,000 ohm $\pm 10\%$, 1/2 w	745 1128 00
V-301	Oscillator	TUBE: type 6BA6; pentode	255 0185 00
XV-301	Socket for V-301	SOCKET, tube: 7 pin miniature	220 1046 00
XY-301	Socket for crystal	SOCKET, crystal: steatite	292 0055 00
Y-301	100 kc calibrator	CRYSTAL: special; 100 kc	291 5954 00
<u>270 G-2 SPEAKER</u>			
LS	Loud speaker	SPEAKER: permanent magnet; 6-8 voice coil impedance, 8 w	271 0076 00

COLLINS RADIO COMPANY

MAIN PLANT:

855 35TH ST. N.E., CEDAR RAPIDS, IOWA

BRANCHES:

1937 IRVING BOULEVARD, DALLAS, TEXAS

11 WEST 42ND STREET, NEW YORK 36, N. Y.

2700 WEST OLIVE AVE., BURBANK, CALIF.

